

UC Berkeley

UC Berkeley Electronic Theses and Dissertations

Title

On the combinatorics of cluster structures on positroid varieties

Permalink

<https://escholarship.org/uc/item/1xm0m1gx>

Author

Sherman-Bennett, Melissa Ulrika

Publication Date

2021

Peer reviewed|Thesis/dissertation

On the combinatorics of cluster structures on positroid varieties

by

Melissa Sherman-Bennett

A dissertation submitted in partial satisfaction of the

requirements for the degree of

Doctor of Philosophy

in

Mathematics

in the

Graduate Division

of the

University of California, Berkeley

Committee in charge:

Professor Lauren Williams, Co-chair

Professor Sylvie Corteel, Co-chair

Professor Mark Haiman

Professor Scott Shenker

Spring 2021

On the combinatorics of cluster structures on positroid varieties

Copyright 2021
by
Melissa Sherman-Bennett

Abstract

On the combinatorics of cluster structures on positroid varieties

by

Melissa Sherman-Bennett

Doctor of Philosophy in Mathematics

University of California, Berkeley

Professor Lauren Williams, Co-chair

Professor Sylvie Corteel, Co-chair

Cluster algebras are a class of commutative rings with a remarkable combinatorial structure, introduced by Fomin and Zelevinsky. A cluster algebra has a distinguished set of generators, called *cluster variables*, which are grouped together into overlapping subsets called *seeds*. This dissertation is concerned with the cluster algebra structure of coordinate rings of open positroid varieties in the Grassmannian. Open positroid varieties are projections of open Richardson varieties from the full flag variety to the Grassmannian. They were studied first by Lusztig and Rietsch in the context of total positivity, and then by Knutson–Lam–Speyer, who connected them to the combinatorics of the *totally nonnegative Grassmannian* developed by Postnikov. Open positroid varieties are smooth, irreducible, and stratify the Grassmannian; open Schubert varieties are a special case.

Seminal work of Scott established that the homogeneous coordinate ring of the Grassmannian is a cluster algebra, and moreover that Postnikov’s *plabic graphs* for the Grassmannian give seeds for this cluster algebra. Postnikov defined plabic graphs not just for the Grassmannian but for all positroid varieties. Accordingly, experts long believed that the coordinate ring of any open positroid variety is also a cluster algebra, with seeds given by plabic graphs. In Chapter 3, which is joint work with Khrystyna Serhiyenko and Lauren Williams, we prove this in the case of *open Schubert varieties* in the Grassmannian. Work of Leclerc on Richardson varieties in the full flag variety implies that the coordinate rings of these varieties are cluster algebras, but does not give any explicit descriptions of seeds. We show that Postnikov’s plabic graphs give seeds in this cluster algebra. For skew Schubert varieties, we show that Leclerc’s cluster algebra is given by *relabelled* plabic graphs, whose boundary vertices are permuted.

Shortly following my work with Serhiyenko and Williams, Galashin–Lam showed that Postnikov’s graphs give a cluster algebra structure on coordinate rings of arbitrary positroid

varieties using similar methods. In Chapter 4, which is joint work with Chris Fraser, we expand on this result to show that positroid varieties admit a number of different cluster structures, with seeds given by relabeled plabic graphs. Along the way, we show that many positroid varieties are isomorphic, using a permuted version of the Muller–Speyer twist map. We conjecture that all of these distinct cluster structures differ only by rescaling, and prove this conjecture for open Schubert varieties. This enlarges the class of combinatorially well-understood seeds for positroid varieties, which provides additional tools to further study the cluster structure on positroid varieties.

Contents

Contents	i
1 Introduction	1
2 Background on cluster algebras and plabic graphs	8
2.1 Cluster algebras	8
2.2 Background on plabic graphs	10
3 A cluster structure on Schubert varieties	15
3.1 Introduction	15
3.2 A lemma on reduced expressions	22
3.3 The rectangles seed associated to a skew Schubert variety	23
3.4 Obtaining the rectangles seed from a bridge graph	24
3.5 Obtaining the rectangles seed from Leclerc’s categorical cluster structure . . .	33
3.6 The proofs of Theorem 3.1.6 and Theorem 3.1.7	56
3.7 Applications	59
3.8 Skew Schubert varieties	63
3.9 A cluster structure not realizable by relabeled plabic graphs	66
4 Many cluster structures on positroid varieties	68
4.1 Introduction	69
4.2 Background on cluster algebras and positroids	72
4.3 Positroid varieties	72
4.4 Relabeled plabic graphs and Grassmannlike necklaces	80
4.5 When relabeled plabic graphs give seeds	84
4.6 Twist isomorphisms from necklaces	91
4.7 Quasi-equivalence and cluster structures from relabeled plabic graphs	102
4.8 Proofs	106
Bibliography	113

Acknowledgments

First and foremost, to my advisor, Lauren Williams: thank you for your invaluable guidance and boundless support, both mathematically and as a woman navigating the academic world. I cannot overstate the impact you had on my time in graduate school; I would not be the mathematician I am today without you. I hope to one day do as much for my students as you do for yours. Thank you also to Sylvie Corteel, for acting as my local advisor at Berkeley and cheerfully signing myriad forms; Bernd Sturmfels for encouraging me to branch out and providing me with the resources to do so; Vicky Lee for answering every question an anxious graduate student can ask; Isabel Seneca for always being willing to check in with Grad Div; and Mark Haiman and Scott Shenker for taking the time to serve on my dissertation committee. I would also like to thank the Harvard Math Department, for their hospitality during my 2-year stint as a visiting student, and MPI Leipzig, for a very enjoyable summer among non-linear algebraists.

To my collaborators, Sunita Chepuri, Chris Fraser, Khrystyna Serhiyenko, Lauren Williams, and Leon Zhang, thank you for sharing your thoughts and expertise with me. I learned so much from working with you.

Thank you to the trailblazing Madeline Brandt, for telling me to apply. To Jess Banks, Paula Burkhardt, Meredith Shea, Mariel Supina, and Maddie Weinstein: my sincere gratitude for conversation, commiseration and community, and for seamlessly picking up the threads whenever I reappeared in Berkeley. To Esther Banaian, Sarah Brauner, Sunita Chepuri, Galen Dorpalen-Berry, and Elizabeth Kelley: thank you for befriending me during my first conferences and sticking with me in the subsequent ones. I look forward to seeing you all at many more. To Mario Sanchez: I'm glad we got through it together, existential dread notwithstanding. Maxim Jeffs, Charles Wang, and Lucy Yang: thanks for ensuring I ate enough gingerbread to survive the Boston winters, and for making Harvard feel a bit like Berkeley.

Thank you to Mark Corsky, at Chamisa Mesa High School, and the faculty of Bard College at Simon's Rock, particularly Bill Dunbar, Jamie Hutchinson, and Clark Musselman, for steering me to where I am now. I am deeply indebted to Katie Faulkner and James Graham, Mo Miner and Randee Paufve, Ilya Vidrin and Marcus Schulkind, for innumerable lessons on balance. Last but not far from least, to my family, Barb, James, Niko, and Leon. Thank you for all that you do.

Chapter 1

Introduction

Cluster algebras are a class of commutative rings with a rich combinatorial structure, introduced by Fomin and Zelevinsky around 2000 [15]. They are equipped with a distinguished set of generators, known as *cluster variables*, which are grouped together into overlapping subsets called *seeds*¹. The cluster variables and seeds of a cluster algebra are defined recursively: given a seed $\Sigma = \{x_1, \dots, x_r\}$, one can *mutate* at any cluster variable x_k to obtain a new seed $\{x_1, \dots, x_r\} \setminus \{x_k\} \cup \{x'_k\}$ with new cluster variable x'_k . One seed Σ determines the cluster algebra $\mathcal{A}(\Sigma)$. The cluster variables of $\mathcal{A}(\Sigma)$ are the ring elements obtained from the initial seed Σ by arbitrary sequences of mutations. In the years since their definition, cluster algebras have been connected to a myriad of other mathematical topics, including representation theory [20], Teichmüller theory [12], mirror symmetry [24], Poisson geometry [22], algebraic combinatorics [8], discrete dynamical systems, and scattering amplitudes in $\mathcal{N} = 4$ super Yang-Mills theory [23].

An example of a cluster algebra is the homogeneous coordinate ring of the Grassmannian $\text{Gr}(2, n)$ of 2-planes in \mathbb{C}^n . The cluster variables are the Plücker coordinates Δ_{ij} , and the seeds are in bijection with triangulations of an n -gon. To see this bijection, label the vertices of the n -gon $1, \dots, n$ going clockwise, and associate the Plücker coordinate Δ_{ij} with the diagonal of the n -gon between vertices i and j . Then two Plücker coordinates Δ_{ij} and Δ_{ab} appear in a seed together if and only if the corresponding diagonals do not cross, and seeds correspond to maximal collections of noncrossing diagonals. Mutating a seed at the cluster variable Δ_{ij} corresponds to “flipping” the diagonal ij in the associated triangulation. See Figure 1.1 for an example.

One motivation for the definition of cluster algebras was to provide an algebraic framework for Lusztig’s dual canonical bases for representations of semisimple Lie groups [31] and the related notion of total positivity [33]. For G a simply-connected connected semisimple Lie group, the coordinate rings of many varieties related to G (including G , double Bruhat cells in G [3], base affine space G/N [3] and partial flag varieties G/P [21]) have the structure of a cluster algebra. Fomin and Zelevinsky conjectured that for these coordinate rings, the

¹Technically, seeds consist of a collection of cluster variables together with some additional combinatorial information, such as a quiver. The combinatorial information is necessary for mutation.

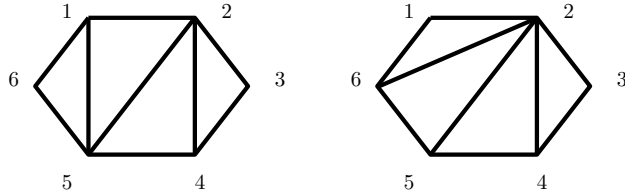

Figure 1.1: On the left, a triangulation of a hexagon corresponding to the seed $\Sigma = \{\Delta_{12}, \Delta_{23}, \dots, \Delta_{56}, \Delta_{16}, \Delta_{15}, \Delta_{25}, \Delta_{24}\}$ in $\mathbb{C}[\text{Gr}(2, 6)]$. Mutating at Δ_{15} produces a new seed $\Sigma' = \Sigma \setminus \{\Delta_{15}\} \cup \{\Delta_{26}\}$, corresponding to the triangulation on the right.

cluster variables, and more generally the monomials in any seed (called *cluster monomials*), are elements of Lusztig’s dual canonical basis [15].

The conjecture on cluster monomials and dual canonical bases has expanded into a thriving line of inquiry in the field: to understand the various bases of cluster algebras, particularly those which contain the cluster monomials. For cluster algebras arising from representation theory, examples are expected, and in some cases known, to include other bases with representation-theoretic significance, such as dual semicanonical bases [20, 25] and Kuperberg’s web basis [13]. For more general cluster algebras, the seminal result on bases is due to Gross, Hacking, Keel, and Kontsevich. They establish that sufficiently nice cluster algebras² have a basis of *theta functions* which includes the cluster monomials [24]. The theta basis has striking positivity properties: it has positive structure constants and every theta function has an expression as a Laurent polynomial in an arbitrary cluster with positive coefficients.

This dissertation is concerned with understanding the cluster monomials of cluster algebras arising as the coordinate ring $\mathbb{C}[V]$ of an affine variety V . We consider V with a fixed embedding in affine space \mathbb{A}^d , so identify $\mathbb{C}[V]$ with $\mathbb{C}[t_1, \dots, t_d]/I$ for some radical ideal I . Even in this case, identifying the cluster variables and monomials is difficult. Cluster algebra machinery gives a way to compute cluster variables and monomials as Laurent polynomials in some initial cluster; going from such an expression to a polynomial in the generators t_1, \dots, t_d of $\mathbb{C}[V]$ is nontrivial. Given two regular functions which are known to be cluster variables, in general the only way to check if their product is a cluster monomial is to exhibit a seed containing both of them—a tall order since most cluster algebras have infinitely many seeds. For this reason, I focus on establishing explicit combinatorial constructions for seeds, and hence cluster monomials, in these cluster algebras. As an added bonus, the seeds arising from the constructions in this thesis have cluster variables manifestly written as polynomial functions in the generators of $\mathbb{C}[V]$.

The varieties under consideration are (affine cones over) open positroid varieties Π° , which are subvarieties of the Grassmannian $\text{Gr}_{k,n}$ of k -planes in \mathbb{C}^n . Open positroid varieties are projections of certain open Richardson varieties in the full flag variety, and were studied

²including all of those appearing here

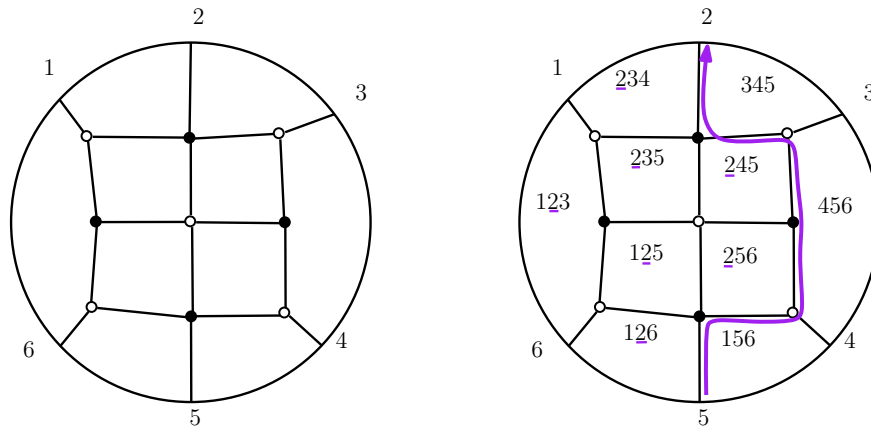

Figure 1.2: On the left, a plabic graph for $\Pi_{3,6}^\circ$. On the right, the corresponding target seed for $\mathbb{C}[\widetilde{\Pi}_{3,6}^\circ]$, with 3-element subsets interpreted as Plücker coordinates. Faces are labeled using the targets of *trips*; one is shown on the right in purple.

in this guise first by Lusztig [32] and Rietsch [43]. Knutson, Lam, and Speyer [28] later coined the name “positroid variety” and gave a number of alternate definitions, using the combinatorics of *positroids* developed by Postnikov [41]. One definition is in terms of the vanishing and non-vanishing of Plücker coordinates; another is as the intersection of n cyclically shifted Schubert cells. The open positroid varieties are smooth, irreducible, and give a stratification of the Grassmannian which refines the Schubert stratification [32]. There is a unique open positroid variety of top dimension, called the “big” open positroid variety $\Pi_{k,n}^\circ$. It is the subset of $\text{Gr}_{k,n}$ where the cyclically consecutive Plücker coordinates $\Delta_{i,i+1,\dots,i+k-1}$ are nonvanishing.

Open positroid varieties are indexed by a number of combinatorial objects, including L-diagrams, decorated permutations, Grassmann necklaces, and equivalence classes of plabic graphs (all due to Postnikov [41]). From the perspective of cluster algebras and seeds, the most useful of these objects are *plabic graphs*, planar bicolored graphs drawn in a disk with boundary vertices $1, \dots, n$ going clockwise (see Figure 1.2). The positroid variety to which a plabic graph G corresponds can be read off of a combinatorial statistic called the *trip permutation* of G .

Plabic graphs appeared very early in the history of cluster algebras, in the context seeds for $\widetilde{\Pi}_{k,n}^\circ$, the affine cone over the big open positroid variety. Scott [46] showed that $\mathbb{C}[\widetilde{\Pi}_{k,n}^\circ]$ is a cluster algebra³, and moreover gave a recipe to produce a seed Σ_G^T in this cluster algebra from each plabic graph G for $\Pi_{k,n}^\circ$ (see Figure 1.2). This recipe uses the *target face labels* of the graph G , so we call Σ_G^T the *target seed* of G . The target seed Σ_G^T consists entirely of Plücker

³Scott had slightly different conventions for cluster algebras, so in fact worked with the affine cone over the Grassmannian, rather than the affine cone over $\Pi_{k,n}^\circ$.

coordinates and, in fact, all seeds for $\mathbb{C}[\tilde{\Pi}_{k,n}^\circ]$ consisting entirely of Plücker coordinates arise from a plabic graph [39]. So plabic graphs give us a good combinatorial understanding of a finite subset of the seeds for $\mathbb{C}[\tilde{\Pi}_{k,n}^\circ]$. This subset is a proper subset of the seeds for $\mathbb{C}[\tilde{\Pi}_{k,n}^\circ]$ in all cases except $k = 2$ and $k = n - 2$.

Scott's recipe to produce the seed Σ_G^T works equally well for arbitrary plabic graphs. So essentially since Scott's result, experts believed it should extend to arbitrary positroid varieties, though this conjecture wasn't written down until [36, Conjecture 3.4].

Conjecture 1.0.1. *Let G be a reduced plabic graph corresponding to an open positroid variety Π° . Then the cluster algebra $\mathcal{A}(\Sigma_G^T)$ with initial seed Σ_G^T is equal to $\mathbb{C}[\tilde{\Pi}^\circ]$, the coordinate ring of the affine cone over Π° .*

Note that if G and H are plabic graphs for the same open positroid variety, then Σ_G^T and Σ_H^T are related by a sequence of mutations. So Conjecture 1.0.1 posits the existence of a single cluster algebra structure on $\mathbb{C}[\tilde{\Pi}^\circ]$, for which each plabic graph for Π° gives a seed.

In the years following Scott's result, partial progress on this conjecture was made by Leclerc [30]. Using cluster category techniques, he showed that coordinate rings of open Richardson varieties in the full flag variety have a subalgebra which is a cluster algebra. In certain cases, he showed this subalgebra is the entire coordinate ring. Because open positroid varieties are isomorphic to certain open Richardson varieties, this established that $\mathbb{C}[\tilde{\Pi}^\circ]$ has a cluster subalgebra which, in some cases, was known to be the whole ring. However, Leclerc's results are phrased in language very different from that of plabic graphs, and his seeds are far from explicit; to compute them, one needs to compute morphisms of modules in a particular preprojective algebra.

In Chapter 3, which is joint work with Khrystyna Serhiyenko and Lauren Williams [47], we prove Conjecture 1.0.1 for *open Schubert varieties*, i.e. open positroid varieties which are dense in some Schubert variety. More precisely, we show the following.

Theorem A (Theorem 3.1.6). *Consider the open Schubert variety X_λ° of $\text{Gr}(k, n)$. Let G be a reduced plabic graph with trip permutation π_λ^ζ . Then the coordinate ring $\mathbb{C}[\tilde{X}_\lambda^\circ]$ of (the affine cone over) X_λ° coincides with the cluster algebra $\mathcal{A}(\Sigma_G^T)$.*

For open Schubert varieties, Leclerc's results tell us that the coordinate rings of an open Schubert variety is a cluster algebra. The problem is determining whether or not plabic graphs give seeds in this cluster algebra. We answer this question in the affirmative, using a construction of Karpman [26]. We also obtain similar results for the more general class of *open skew Schubert varieties*, with an interesting combinatorial variation. Leclerc's cluster algebra is again the entire coordinate ring in this case. We show that seeds in this cluster algebra are given by *reabeled plabic graphs* for Π° , whose boundary vertices (read clockwise) are a particular permutation of $1, \dots, n$.

Theorem B (Theorem 3.1.7). *Consider the open skew Schubert variety $\pi_k(\mathcal{R}_{v,w})$. Let G be a reduced plabic graph with trip permutation $vw^{-1} = x^{-1}$. Apply v^{-1} to the boundary*

vertices of G , obtaining the relabeled graph $\overline{G^{v-1}}$, and apply the target labeling to obtain the seed $\Sigma_{G^{v-1}}^T$. Then the coordinate ring $\mathbb{C}[\pi_k(\mathcal{R}_{v,w})]$ of (the affine cone over) the open skew Schubert variety $\pi_k(\mathcal{R}_{v,w})$ coincides with the cluster algebra $\mathcal{A}(\Sigma_{G^{v-1}}^T)$.

Shortly after [47], Galashin and Lam used similar methods to prove Conjecture 1.0.1 for arbitrary open positroid varieties [19]. However, Galashin and Lam used a slightly different combinatorial procedure to obtain a seed from a plabic graph G ; rather than use the target face labels, they use the *source face labels* to obtain the *source seed* Σ_G^S . Though this may seem like an innocuous convention difference, in fact the source seed Σ_G^S and target seed Σ_G^T are usually not related by any sequence of mutations. That is, the cluster algebra with initial seed Σ_G^T and the cluster algebra with initial seed Σ_G^S have different cluster variables. *A priori*, they may have different cluster monomials and different theta bases.

So using the results of [47] and [19], the coordinate ring $\mathbb{C}[\tilde{\Pi}^\circ]$ of an open Schubert variety can be identified with two different cluster algebras: the “target” cluster algebra, whose seeds include the target seeds Σ_G^T and the “source” cluster algebra, whose seeds include the source seeds Σ_G^S . Similarly, coordinate rings of open skew Schubert varieties also have two different cluster algebra structures, one given by source seeds of plabic graphs and the other given by target seeds of certain relabeled plabic graphs. It is very natural to ask what the relationship between these cluster algebras is. For example, do they give rise to different bases of $\mathbb{C}[\tilde{\Pi}^\circ]$?

In Chapter 4, which is joint work with Chris Fraser [18], we address a generalization of this question. First, we show that the coordinate ring of any open positroid variety admits many cluster algebra structures. Each of these cluster algebras has a combinatorial source for seeds: relabeled plabic graphs with a fixed boundary. We characterize exactly which relabeled plabic graphs give a cluster algebra structure on $\mathbb{C}[\tilde{\Pi}^\circ]$.

Theorem C (Theorem 4.1.2). *Suppose $\pi, \rho \in S_n$ such that $\pi\rho \leq_o \pi$ and set $\mu = \rho^{-1}\pi\rho$. Let G be a reduced plabic graph with trip permutation μ , so that G^ρ has trip permutation π . Then the following are equivalent:*

1. $\Sigma_{G^\rho}^T$ is a seed in $\mathbb{C}(\tilde{\Pi}_\pi^\circ)$ and $\mathcal{A}(\Sigma_{G^\rho}^T) = \mathbb{C}[\tilde{\Pi}_\pi^\circ]$.
2. The number of faces of G^ρ is $\dim \tilde{\Pi}_\pi^\circ$. Equivalently, $\dim \tilde{\Pi}_\pi^\circ = \dim \tilde{\Pi}_\mu^\circ$.
3. The Plücker coordinates $\vec{\mathbb{F}}^\bullet(G^\rho)$ associated to the boundary faces (equivalently, to all faces) of G^ρ are a weakly separated collection.
4. The open positroid varieties $\tilde{\Pi}_\pi^\circ$ and $\tilde{\Pi}_\mu^\circ$ are isomorphic.

Moreover, if any (hence, all) of the above conditions hold, the positive part of $\tilde{\Pi}_\pi^\circ$ determined by $\Sigma_{G^\rho}^T$ is the positroid cell $\tilde{\Pi}_{\pi, > 0}^\circ$.

Figure 1.3 illustrates Theorem C.

Among the seeds covered by Theorem C are the target seed Σ_H^T and source seed Σ_H^S for H a usual plabic graph with trip permutation π , as well as the seeds $\Sigma_{G^{v-1}}^T$ defined in Theorem B

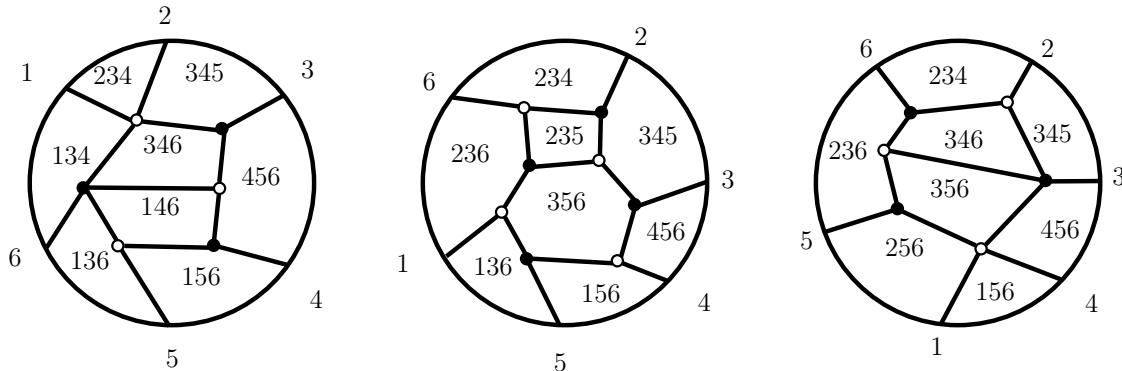

Figure 1.3: On the left, a plabic graph with target face labels for an open Schubert variety X in $\text{Gr}(3, 6)$. Center and right: 2 relabeled plabic graphs, together with target face labels. Each graph defines a different cluster algebra, equal to $\mathbb{C}[\tilde{X}]$. The seeds in each of these cluster algebras are related by rescaling.

for open skew Schubert varieties. The seeds Σ_H^T and $\Sigma_{G^\rho}^T$ are *not* related by mutation unless ρ is the identity. However, for Schubert varieties, we show that they are related by a *quasi-cluster transformation*; that is, a sequence of mutations followed by rescaling by elements of the seed.

Theorem D (Theorem 4.7.12). *Suppose $\tilde{\Pi}_\pi^\circ$ is an open Schubert or opposite open Schubert variety. Suppose H is a plabic graph with trip permutation π , and G^ρ is a relabeled plabic graph with trip permutation π satisfying the conditions of Theorem C. Then the seeds Σ_H^T and $\Sigma_{G^\rho}^T$ are related by a quasi-cluster transformation.*

Theorem D shows that, for open Schubert varieties, each relabeled graph satisfying the conditions of Theorem C gives rise to a seed in the target cluster algebra and (for a different choice of rescaling) a seed in the source cluster algebra. In particular, it implies that each relabeled graph cluster algebra, including the source and target, give rise to the same cluster monomials and theta bases on $\mathbb{C}[\tilde{\Pi}^\circ]$. We also show a weaker statement for the larger class of *toggle-connected* positroids: that the source seed Σ_G^S and the target seed Σ_G^T for a usual plabic graph are related by a quasi-cluster transformation, proving a conjecture of Muller–Speyer (see Conjecture 4.1.1).

We further conjecture that Theorem D holds for arbitrary open positroid varieties (Conjecture 4.1.3). In light of this conjecture, we view relabeled plabic graphs as an additional source for combinatorially well-understood seeds in the target cluster structure on $\mathbb{C}[\tilde{\Pi}^\circ]$. This gives us additional tools to understand the target cluster structure, which is at present rather mysterious. For example, it is unknown if Plücker coordinates are in the theta basis for $\mathbb{C}[\tilde{\Pi}^\circ]$. It is natural to conjecture that all nonvanishing Plücker coordinates Δ_I on $\tilde{\Pi}^\circ$ are cluster monomials in $\mathbb{C}[\tilde{\Pi}^\circ]$; if they are, the natural seeds to consider are the relabeled

plabic graph seeds. One might also hope that relabeled plabic graphs give all seeds for $\tilde{\Pi}^\circ$ whose cluster variables are Laurent monomials in Plücker coordinates, just as usual plabic graphs give all the Plücker coordinate seeds for $\tilde{\Pi}_{k,n}^\circ$.

Outline. The dissertation is structured as follows. Chapter 2 contains background material on cluster algebras and plabic graphs, their trip permutations, and the source and target seed constructions. Chapter 3 contains results on cluster structures for coordinate rings of open Schubert and skew Schubert varieties. Chapter 4 contains results on relabeled plabic graph cluster structures for coordinate rings of arbitrary open positroid varieties.

Chapter 2

Background on cluster algebras and plabic graphs

In this chapter, we recall background on cluster algebras and the combinatorics of plabic graphs, parts of which appeared in [18, 47]. We delay the definition of open Schubert and positroid varieties to Chapter 3 and Chapter 4, respectively.

2.1 Cluster algebras

Cluster algebras are a class of rings with a particular combinatorial structure; they were introduced by Fomin and Zelevinsky in [15].

Definition 2.1.1 (*Quiver*). A *quiver* Q is a directed graph; we will assume that Q has no loops or 2-cycles. Each vertex is designated either *mutable* or *frozen*.

Definition 2.1.2 (*Quiver Mutation*). Let q be a mutable vertex of quiver Q . The quiver mutation μ_q transforms Q into a new quiver $Q' = \mu_q(Q)$ via a sequence of three steps:

1. For each oriented two path $r \rightarrow q \rightarrow s$, add a new arrow $r \rightarrow s$ (unless r and s are both frozen, in which case do nothing).
2. Reverse the direction of all arrows incident to the vertex q .
3. Repeatedly remove oriented 2-cycles until unable to do so.

We say that two quivers Q and Q' are *mutation equivalent* if Q can be transformed into a quiver isomorphic to Q' by a sequence of mutations.

Definition 2.1.3 (*Labeled seeds*). Choose $M \geq N$ positive integers. Let \mathcal{F} be an *ambient field* of rational functions in N independent variables over $\mathbb{C}(x_{N+1}, \dots, x_M)$. A *labeled seed* in \mathcal{F} is a pair $(\tilde{\mathbf{x}}, Q)$, where

- $\tilde{\mathbf{x}} = (x_1, \dots, x_M)$ forms a free generating set for \mathcal{F} , and
- Q is a quiver on vertices $1, 2, \dots, N, N+1, \dots, M$, whose vertices $1, 2, \dots, N$ are *mutable*, and whose vertices $N+1, \dots, M$ are *frozen*.

We refer to $\tilde{\mathbf{x}}$ as the (labeled) *extended cluster* of a labeled seed $(\tilde{\mathbf{x}}, Q)$. The variables $\{x_1, \dots, x_N\}$ are called *cluster variables*, and the variables $c = \{x_{N+1}, \dots, x_M\}$ are called *frozen* or *coefficient variables*. We often view the labeled seed as a quiver Q where each vertex i is labeled by the corresponding variable x_i .

Definition 2.1.4 (*Seed mutations*). Let $(\tilde{\mathbf{x}}, Q)$ be a labeled seed in \mathcal{F} , and let $q \in \{1, \dots, N\}$. The *seed mutation* μ_q in direction q transforms $(\tilde{\mathbf{x}}, Q)$ into the labeled seed $\mu_q(\tilde{\mathbf{x}}, Q) = (\tilde{\mathbf{x}}', \mu_q(Q))$, where the cluster $\tilde{\mathbf{x}}' = (x'_1, \dots, x'_M)$ is defined as follows: $x'_j = x_j$ for $j \neq q$, whereas $x'_q \in \mathcal{F}$ is determined by the *exchange relation*

$$x'_q x_q = \prod_{q \rightarrow r} x_r + \prod_{s \rightarrow q} x_s, \quad (2.1.1)$$

where the first product is over all arrows $q \rightarrow r$ in Q which start at q , and the second product is over all arrows $s \rightarrow q$ which end at q .

Remark 2.1.5. It is not hard to check that seed mutation is an involution.

Remark 2.1.6. Note that arrows between two frozen vertices of a quiver do not affect seed mutation (they do not affect the mutated quiver or the exchange relation). For that reason, one may omit arrows between two frozen vertices.

Definition 2.1.7 (*Patterns*). Consider the N -regular tree \mathbb{T}_N whose edges are labeled by the numbers $1, \dots, N$, so that the N edges emanating from each vertex receive different labels. A *cluster pattern* is an assignment of a labeled seed $\Sigma_t = (\tilde{\mathbf{x}}_t, Q_t)$ to every vertex $t \in \mathbb{T}_N$, such that the seeds assigned to the endpoints of any edge $t \xrightarrow{q} t'$ are obtained from each other by the seed mutation in direction q . The components of $\tilde{\mathbf{x}}_t$ are written as $\tilde{\mathbf{x}}_t = (x_{1;t}, \dots, x_{N;t})$.

Clearly, a cluster pattern is uniquely determined by an arbitrary seed.

Definition 2.1.8 (*Cluster algebra*). Given a cluster pattern, we denote

$$\mathcal{X} = \bigcup_{t \in \mathbb{T}_N} \tilde{\mathbf{x}}_t = \{x_{i,t} : t \in \mathbb{T}_N, 1 \leq i \leq N\}, \quad (2.1.2)$$

the union of clusters of all the seeds in the pattern. The elements $x_{i,t} \in \mathcal{X}$ are called *cluster variables*. The *cluster algebra* \mathcal{A} associated with a given pattern is the $\mathbb{C}[x_{N+1}^{\pm 1}, \dots, x_M^{\pm 1}]$ -subalgebra of the ambient field \mathcal{F} generated by all cluster variables: $\mathcal{A} = \mathbb{C}[c^{\pm 1}][\mathcal{X}]$. We denote $\mathcal{A} = \mathcal{A}(\tilde{\mathbf{x}}, Q)$, where $(\tilde{\mathbf{x}}, Q)$ is any seed in the underlying cluster pattern. In this generality, \mathcal{A} is called a *cluster algebra from a quiver*, or a *skew-symmetric cluster algebra of geometric type*. We say that \mathcal{A} has *rank* N because each cluster contains N cluster variables.

Remark 2.1.9. Throughout this dissertation, we restrict our attention to the following situation. Let V be a rational affine algebraic variety with algebra of regular functions $\mathbb{C}[V]$. The ambient field is the field $\mathbb{C}(V)$ of rational functions on V . We are interested in seed patterns in $\mathbb{C}(V)$ with extended clusters of size $\dim V$, whose frozen variables are units in $\mathbb{C}[V]$.

We denote by $\mathbb{P} \subset \mathbb{C}(V)$ the abelian group of Laurent monomials in the frozen variables. Under the assumptions of Remark 2.1.9, we in fact have $\mathbb{P} \subset \mathbb{C}[V]$.

A seed pattern in $\mathbb{C}(V)$ determines a *cluster structure* on V if $\mathcal{A}(\Sigma) = \mathbb{C}[V]$ for some (hence any) seed Σ in the seed pattern. In an abuse of language, we also say that a seed Σ determines a cluster structure on V if its seed pattern does.

Suppose Σ determines a cluster structure on V . This endows V with the following structures:

- A set of *cluster monomials* in $\mathbb{C}[V]$. These are elements $f \in \mathbb{C}[V]$ that can be expressed in the form $f = \frac{M_1}{M_2}$ where M_1 is a monomial in the variables of some cluster in the seed pattern, and $M_2 \in \mathbb{P}$ is a monomial in the frozen variables. Thus, our definition of cluster monomial allows frozen variables in the denominator.
- A *totally positive part* $V_{>0} \subset V$. This is the subset where all cluster variables (equivalently, all variables in any particular cluster) evaluate positively.
- For each seed Σ in the seed pattern, a rational map $V \rightarrow (\mathbb{C}^*)^m$ given by evaluating the cluster variables. We call its domain of definition the *cluster torus* $V_\Sigma \subset V$. By the Laurent phenomenon for cluster algebras, there is an inverse map $(\mathbb{C}^*)^m \hookrightarrow V$, an open embedding we refer to as the *cluster chart*.

Remark 2.1.10. One of the earliest definitions of cluster algebra defined it as $\mathcal{A} = \mathbb{C}[c][\mathcal{X}]$ instead of $\mathcal{A} = \mathbb{C}[c^{\pm 1}][\mathcal{X}]$. This is the definition Scott worked with in proving that the coordinate ring of the Grassmannian is a cluster algebra [46]. If one uses Definition 2.1.8 instead, then the statement is that the coordinate ring of the big open positroid variety in the Grassmannian is a cluster algebra. In fact the latter statement was verified in [22, Section 3.3], who exhibited an initial quiver which is the one from the *rectangles seed* we discuss in Section 3.3.

2.2 Background on plabic graphs

In this section we review Postnikov’s notion of *plabic graphs* [41], which we will then use to define cluster structures in Schubert varieties in Chapter 3 and positroid varieties in Chapter 4.

Definition 2.2.1. A *plabic (or planar bicolored) graph* is an undirected graph G drawn inside a disk (considered modulo homotopy) with n *boundary vertices* on the boundary of

the disk, labeled $1, \dots, n$ in clockwise order, as well as some colored *internal vertices*. These internal vertices are strictly inside the disk and are colored in black and white. An internal vertex of degree one adjacent to a boundary vertex is a *lollipop*. We will always assume that no vertices of the same color are adjacent, and that each boundary vertex i is adjacent to a single internal vertex.

See Figure 2.1 for an example of a plabic graph.

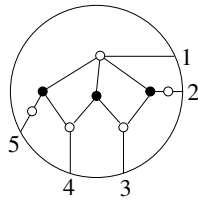

Figure 2.1: A plabic graph.

Definition 2.2.2. A *relabelled plabic graph* is a plabic graph with boundary vertices are labeled by $1, \dots, n$ in some order, not necessarily clockwise.

Relabeled plabic graphs naturally arise in the course of our arguments. Though we state all of the following definitions for plabic graphs for clarity, they can equally be made for relabeled plabic graphs.

There is a natural set of local transformations (moves) of plabic graphs, which we now describe. Note that we will always assume that a plabic graph G has no isolated components (i.e. every connected component contains at least one boundary vertex). We will also assume that G is *leafless*, i.e. if G has an internal vertex of degree 1, then that vertex must be adjacent to a boundary vertex.

(M1) **SQUARE MOVE** (Urban renewal). If a plabic graph has a square formed by four trivalent vertices whose colors alternate, then we can switch the colors of these four vertices (and add some degree 2 vertices to preserve the bipartiteness of the graph).

(M2) **CONTRACTING/EXPANDING A VERTEX**. Any degree 2 internal vertex not adjacent to the boundary can be deleted, and the two adjacent vertices merged. This operation can also be reversed. Note that this operation can always be used to change an arbitrary square face of G into a square face whose four vertices are all trivalent.

(M3) **MIDDLE VERTEX INSERTION/REMOVAL**. We can always remove or add degree 2 vertices at will, subject to the condition that the graph remains bipartite.

See Figure 2.2 for depictions of these three moves.

(R1) **PARALLEL EDGE REDUCTION**. If a plabic graph contains two trivalent vertices of different colors connected by a pair of parallel edges, then we can remove these vertices and edges, and glue the remaining pair of edges together.



Figure 2.2: A square move, an edge contraction/expansion, and a vertex insertion/removal.

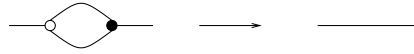

Figure 2.3: Parallel edge reduction

Definition 2.2.3. Two plabic graphs are called *move-equivalent* if they can be obtained from each other by moves (M1)-(M3). The *move-equivalence class* of a given plabic graph G is the set of all plabic graphs which are move-equivalent to G . A leafless plabic graph without isolated components is called *reduced* if there is no graph in its move-equivalence class to which we can apply (R1).

Definition 2.2.4. A *decorated permutation* π is a permutation $\pi \in S_n$ together with a coloring $\{i \mid \pi(i) = i\} \rightarrow \{\text{black, white}\}$.

Definition 2.2.5. Given a reduced plabic graph G , a *trip* T is a directed path which starts at some boundary vertex i , and follows the “rules of the road”: it turns (maximally) right at a black vertex, and (maximally) left at a white vertex. Note that T will also end at a boundary vertex j ; we then refer to this trip as $T_{i \rightarrow j}$. Setting $\pi(i) = j$ for each such trip, we associate a (decorated) *trip permutation* $\pi_G = \pi(1) \dots \pi(n)$ to each reduced plabic graph G , where a fixed point $\pi(i) = i$ is colored white (black) if there is a white (black) lollipop at boundary vertex i .

As an example, the trip permutation associated to the reduced plabic graph in Figure 2.1 is 34512.

Remark 2.2.6. Note that the trip permutation of a plabic graph is preserved by the local moves (M1)-(M3), but not by (R1). For reduced plabic graphs the converse holds, namely it follows from [41, Theorem 13.4] that any two reduced plabic graphs with the same trip permutation are move-equivalent.

Now we use the notion of trips to label each face of G by a Plücker coordinate. Towards this end, note that every trip will partition the faces of a plabic graph into two parts: those on the left of the trip, and those on the right of a trip.

Definition 2.2.7. Let G be a reduced plabic graph with b boundary vertices. For each one-way trip $T_{i \rightarrow j}$ with $i \neq j$, we place the label i (respectively, j) in every face which is to the left of $T_{i \rightarrow j}$. If $i = j$ (that is, i is adjacent to a lollipop), we place the label i in all faces if

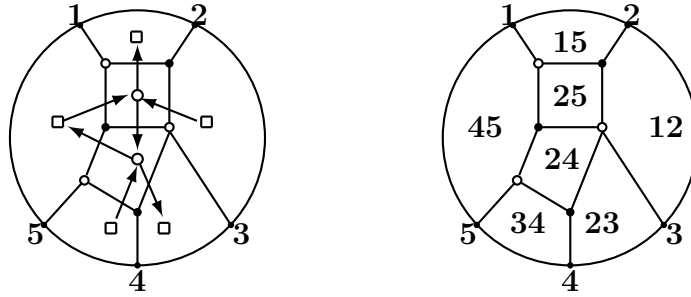

Figure 2.4: A plabic graph G together with $Q(G)$ and its source face labeling.

the lollipop is white and in no faces if the lollipop is black. We then obtain a labeling $\overleftarrow{\mathbb{F}}(G)$ (respectively, $\overrightarrow{\mathbb{F}}(G)$) of faces of G by subsets of $[b]$ which we call the *source* (respectively, *target*) *labeling* of G . We denote the source label (resp. target label) of a face F by $\overleftarrow{I}(F)$ (resp. $\overrightarrow{I}(F)$)¹. We identify each a -element subset of $[b]$ with the corresponding Plücker coordinate.

The right-hand side of Figure 2.4 shows a plabic graph with the face labeling $\overleftarrow{\mathbb{F}}(G)$.

We next associate a quiver to each plabic graph, and relate quiver mutation to moves on plabic graphs.

Definition 2.2.8. Let G be a reduced plabic graph. We associate a quiver $Q(G)$ as follows. The vertices of $Q(G)$ are labeled by the faces of G . We say that a vertex of $Q(G)$ is *frozen* if the corresponding face is incident to the boundary of the disk, and is *mutable* otherwise. For each edge e in G which separates two faces, at least one of which is mutable, we introduce an arrow connecting the faces; this arrow is oriented so that it “sees the white endpoint of e to the left and the black endpoint to the right” as it crosses over e . We then remove oriented 2-cycles from the resulting quiver, one by one, to get $Q(G)$. See Figure 2.4.

Definition 2.2.9. Given a reduced plabic graph G , we let Σ_G^T (respectively, Σ_G^S) be the labeled seed consisting of the quiver $Q(G)$ with vertices labeled by the Plücker coordinates $\overrightarrow{\mathbb{F}}(G)$ (respectively, $\overleftarrow{\mathbb{F}}(G)$). Given a plabic graph G on n vertices and a permutation $v \in S_n$, we will sometimes use relabeled plabic graphs $G^{v^{-1}}$ (where the boundary vertices have been modified by applying v^{-1} to them). We will refer to the corresponding seeds with the induced target labelings by e.g. $\Sigma_{G^{v^{-1}}}^T$.

The following lemma is straightforward, and is implicit in [46].

¹The location of the dot in the notations $\overrightarrow{I}(F)$ versus $\overleftarrow{I}(F)$ indicates that this labeling records the target vs source of trips; the orientation of the arrow is meant as a reminder that the boundary faces are labeled by the forward or reverse Grassmann necklace (see Definition 4.3.4)

Lemma 2.2.10. *If G and G' are related via a square move at a face, then Σ_G^T and $\Sigma_{G'}^T$ are related via mutation at the corresponding vertex. Similarly for Σ_G^S and $\Sigma_{G'}^S$.*

Because of Lemma 2.2.10, we will subsequently refer to “mutating” at a nonboundary face of G , meaning that we mutate at the corresponding vertex of quiver $Q(G)$. Note that in general the quiver $Q(G)$ admits mutations at vertices which do not correspond to moves of plabic graphs. For example, G might have a hexagonal face, all of whose vertices are trivalent; in that case, $Q(G)$ admits a mutation at the corresponding vertex, but there is no move of plabic graphs which corresponds to this mutation.

Chapter 3

A cluster structure on Schubert varieties

The work in this chapter is joint with Khrystyna Serhiyenko and Lauren Williams and has been published in *Proceedings of the London Mathematical Society* [47]. We are grateful to Bernard Leclerc for numerous helpful discussions, and for bringing the work of Chevalier [9] to our attention. We would also like to thank an anonymous referee for helpful suggestions on the exposition. All three authors gratefully acknowledge the support of the National Science Foundation: an NSF graduate research fellowship (M.S.B.), an NSF Mathematical Sciences postdoctoral fellowship (K.S.), and grant No. DMS-1600447 (L.W.). Any opinions, findings and conclusions or recommendations expressed in this material are those of the authors and do not necessarily reflect the views of the National Science Foundation.

3.1 Introduction

The main goal of this chapter is to show that the coordinate ring of (the affine cone over) any (open) Schubert variety of the Grassmannian (embedded into projective space via the Plücker embedding) can be identified with a cluster algebra, whose combinatorial structure is described explicitly in terms of plabic graphs. More precisely, we prove Conjecture 1.0.1 for the case of open Schubert varieties.

Partial progress towards this conjecture was made by Leclerc [30]; his work will be a key tool here. Leclerc constructed a subcategory $\mathcal{C}_{v,w}$ of the module category of the preprojective algebra, that has a cluster structure, to show that the coordinate ring of each open Richardson variety $\mathcal{R}_{v,w}$ of the complete flag variety contains a subalgebra which is a cluster algebra; when w has a factorization of the form $w = xv$ with $\ell(w) = \ell(x) + \ell(v)$ (Leclerc refers to this as “Property (P)”), he showed that this subalgebra coincides with the coordinate ring [30, Proposition 5.1]. Because open Schubert varieties are isomorphic to open Richardson varieties with Property (P), Leclerc’s result implies that their coordinate rings admit a cluster structure. However, Leclerc’s description of the cluster structure is very different from the

plabic graph description and is far from explicit: e.g. his cluster quiver is defined in terms of morphisms of modules of the preprojective algebra.

In this chapter, we prove Conjecture 1.0.1 for Schubert varieties by relating Leclerc’s cluster structure to the conjectural one coming from plabic graphs. We also generalize our result to construct cluster structures in skew Schubert varieties (which also satisfy Property (P)); interestingly, these cluster structures for skew Schubert varieties depart from the one in Conjecture 1.0.1, since they use *relabelled* plabic graphs (with boundary vertices which are not longer cyclically labeled).

Once we have proved that the coordinate rings of (open) Schubert and skew Schubert varieties have cluster structures, we obtain a number of results “for free” from the cluster theory, including the Laurent phenomenon and the Positivity theorem for cluster variables. As a consequence of our results we also obtain many combinatorially explicit cluster seeds for each (open) Schubert and skew Schubert variety. Note that (open) Schubert varieties provide examples of cluster structures of all the finite type simply-laced cluster types (*ADE*), see Section 3.7. Combining our main results with [36, Theorem 3.3] and [35], we find that the coordinate rings of (open) Schubert and skew Schubert varieties (viewed as cluster algebras) are *locally acyclic*, which implies that each one is finitely generated, normal, locally a complete intersection, and equal to its own upper cluster algebra. Combining our result with [16, Theorem 1.2], we find that the quivers giving rise to the cluster structures for Schubert and skew Schubert varieties admit *green-to-red sequences*, which by [24] implies that the cluster algebras have *Enough Global Monomials* and hence each coordinate ring has a canonical basis of theta functions, parameterized by the lattice of g -vectors. Finally we obtain applications to the structure of indecomposable summands of cluster-tilting modules in $\mathcal{C}_{v,w}$ and the morphisms between them.

Notation for the flag variety

Let GL_n denote the general linear group, B the Borel subgroup of lower triangular matrices, B^+ the opposite Borel subgroup of upper triangular matrices, and $W = S_n$ the Weyl group (which is in this case the symmetric group on n letters). W is generated by the simple reflections s_i for $1 \leq i \leq n-1$, where s_i is the transposition exchanging i and $i+1$, and it contains a longest element, which we denote by w_0 , with $\ell(w_0) = \binom{n}{2}$. The *complete flag variety* Fl_n is the homogeneous space $B \backslash \mathrm{GL}_n$. Concretely, each element g of GL_n gives rise to a flag of subspaces $\{V_1 \subset V_2 \subset \dots \subset V_n\}$, where V_i denotes the span of the top i rows of g . The action of B on the left preserves the flag, so we can identify Fl_n with the set of *flags* $\{V_1 \subset V_2 \subset \dots \subset V_n\}$ where $\dim V_i = i$.

Let $\pi : \mathrm{GL}_n \rightarrow \mathrm{Fl}_n$ denote the natural projection $\pi(g) := Bg$. The Bruhat decomposition

$$\mathrm{GL}_n = \bigsqcup_{w \in W} B\dot{w}B,$$

where \dot{w} is a matrix representative for w in GL_n , projects to the Schubert decomposition

$$\mathrm{Fl}_n = \bigsqcup_{w \in W} C_w.$$

Here $C_w = \pi(B\dot{w}B)$ denotes the *Schubert cell* associated to w , isomorphic to $\mathbb{C}^{\ell(w)}$. We also have the Birkhoff decomposition

$$\mathrm{GL}_n = \bigsqcup_{w \in W} B\dot{w}B^+,$$

which projects to the opposite Schubert decomposition

$$\mathrm{Fl}_n = \bigsqcup_{w \in W} C^w$$

where $C^w = \pi(B\dot{w}B^+)$ is the *opposite Schubert cell* associated to w , isomorphic to $\mathbb{C}^{\ell(w_0) - \ell(w)}$.

The intersection

$$\mathcal{R}_{v,w} := C^v \cap C_w$$

has been considered by Kazhdan and Lusztig [27] in relation to Kazhdan-Lusztig polynomials. $\mathcal{R}_{v,w}$ is nonempty only if $v \leq w$ in the Bruhat order of W , and it is then a smooth irreducible locally closed subset of C_w of dimension $\ell(w) - \ell(v)$. Sometimes $\mathcal{R}_{v,w}$ is called an *open Richardson variety* [28] because its closure is a *Richardson variety* [42]. We have a stratification of the complete flag variety

$$\mathrm{Fl}_n = \bigsqcup_{v \leq w} \mathcal{R}_{v,w}.$$

Notation for the Grassmannian

Fix $1 < k < n$. The parabolic subgroup $W_K = \langle s_1, \dots, s_{k-1} \rangle \times \langle s_{k+1}, s_{k+2}, \dots, s_{n-1} \rangle < W$ gives rise to a parabolic subgroup P_K in GL_n , namely $P_K = \bigsqcup_{w \in W_K} B\dot{w}B$, where \dot{w} is a matrix representative for w in GL_n . W_K contains a longest element, which we denote by w_K , with $\ell(w_K) = \binom{k}{2} + \binom{n-k}{2}$.

The *Grassmannian* $\mathrm{Gr}(k, n)$ is the homogeneous space $P_K \backslash \mathrm{GL}_n$. We can think of the Grassmannian $\mathrm{Gr}(k, n) = P_K \backslash \mathrm{GL}_n$ more concretely as the set of all k -planes in an n -dimensional vector space \mathbb{C}^n . An element of $\mathrm{Gr}(k, n)$ can be viewed as a full rank $k \times n$ matrix of rank k , modulo left multiplication by invertible $k \times k$ matrices. That is, two $k \times n$ matrices of rank k represent the same point in $\mathrm{Gr}(k, n)$ if and only if they can be obtained from each other by invertible row operations.

For integers a, b , let $[a, b]$ denote $\{a, a+1, \dots, b-1, b\}$ if $a \leq b$ and the empty set otherwise. We use the shorthand $[n] := [1, n]$. Let $\binom{[n]}{k}$ the set of all k -element subsets of $[n]$.

Given $V \in \mathrm{Gr}(k, n)$ represented by a $k \times n$ matrix A , for $I \in \binom{[n]}{k}$ we let $\Delta_I(V)$ be the maximal minor of A located in the column set I . The $\Delta_I(V)$ do not depend on our choice of matrix A (up to simultaneous rescaling by a nonzero constant), and are called the *Plücker coordinates* of V . The Plücker coordinates give an embedding of $\mathrm{Gr}(k, n)$ into projective space of dimension $\binom{n}{k} - 1$.

We have the usual projection π_k from the complete flag variety Fl_n to the Grassmannian $\mathrm{Gr}(k, n)$. Let $W^K = W_{\min}^K$ and W_{\max}^K denote the set of minimal- and maximal-length coset

representatives for $W_K \setminus W$; we also let ${}^K W$ (or ${}_{\min}^K W$) denote the set of minimal-length coset representatives for W/W_K . Such a permutation $\sigma \in S_n$ is called a *Grassmannian permutation* of type (k, n) ; it has the property that it has at most one descent, and when present, that descent must be in position k , i.e. $\sigma(k) > \sigma(k+1)$.

Rietsch studied the projections of the open Richardson varieties in the complete flag variety to partial flag varieties [43]. In particular, when $v \in W_{\max}^K$ (or when $w \in W_{\min}^K$), the projection π_k is an isomorphism from $\mathcal{R}_{v,w}$ to $\pi_k(\mathcal{R}_{v,w})$. We obtain a stratification

$$\text{Gr}(k, n) = \bigsqcup \pi_k(\mathcal{R}_{v,w})$$

where (v, w) range over all $v \in W_{\max}^K$, $w \in W$, such that $v \leq w$. Following work of Postnikov [41, 28], the strata $\pi_k(\mathcal{R}_{v,w})$ are sometimes called *open positroid varieties*, while their closures are called *positroid varieties*. See Section 4.2 for other descriptions of positroid varieties, given by Knutson–Lam–Speyer.

It follows from the definitions (see e.g. [28, Section 6]) that positroid varieties include Schubert and opposite Schubert varieties in the Grassmannians, which we now define.

Definition 3.1.1. Let I denote a k -element subset of $[n]$. The *Schubert cell* Ω_I is defined to be

$$\Omega_I = \{A \in \text{Gr}(k, n) \mid \text{the lexicographically minimal nonvanishing Plucker coordinate of } A \text{ is } \Delta_I(A)\}.$$

The *Schubert variety* X_I is defined to be the closure $\overline{\Omega_I}$ of Ω_I .

Meanwhile the *opposite Schubert cell* Ω^I is defined to be

$$\Omega^I = \{A \in \text{Gr}(k, n) \mid \text{the lexicographically maximal nonvanishing Plucker coordinate of } A \text{ is } \Delta_I(A)\}.$$

The *opposite Schubert variety* X^I is defined to be the closure $\overline{\Omega^I}$ of Ω^I .

It's easy to see that elements v of W_{\max}^K and elements w of W_{\min}^K are also in bijection with k -element subsets of $[n]$, which we denote by $I(v)$ and $I(w)$, respectively. When $w \in W_{\min}^K$, $\overline{\pi_k(\mathcal{R}_{e,w})}$ is isomorphic to the *opposite Schubert variety* $X^{I(w)}$ in the Grassmannian, which has dimension $\ell(w)$. We therefore refer to $\pi_k(\mathcal{R}_{e,w})$ as an *open opposite Schubert variety*. Similarly, when $v \in W_{\max}^K$, $\overline{\pi_k(\mathcal{R}_{v,w_0})}$ is isomorphic to the *Schubert variety* $X_{I(v)}$ in the Grassmannian, which has dimension $\ell(w_0) - \ell(v)$. We refer to $\pi_k(\mathcal{R}_{v,w_0})$ as an *open Schubert variety*. More generally, if $v \in W_{\max}^K$ and $w \in W$ has a factorization of the form $w = xv$ which is *length-additive*, i.e. where $\ell(w) = \ell(x) + \ell(v)$, then we refer to $\overline{\pi_k(\mathcal{R}_{v,w})}$ (respectively, $\pi_k(\mathcal{R}_{v,w})$) as a *skew Schubert variety* (respectively, open skew Schubert variety). See Section 3.8 for more discussion of skew Schubert varieties, including some justification for the terminology.

Remark 3.1.2. The reader should be cautioned that open Schubert varieties and open opposite Schubert varieties, as defined above, are positroid varieties, but are *not* Schubert cells or opposite Schubert cells. Each open (opposite) Schubert variety is a proper subset

of the corresponding Schubert cell. For example, consider the Grassmannian $Gr_{1,3} = \mathbb{P}^2$ with homogenous coordinates $(x_1 : x_2 : x_3)$. The largest Schubert cell is $x_1 \neq 0$, while the corresponding open Schubert variety is the subset of $Gr_{1,3}$ defined by $x_1 x_2 x_3 \neq 0$.

Let λ denote a Young diagram contained in a $k \times (n-k)$ rectangle. We can identify λ with the lattice path L_λ^\swarrow in the rectangle taking steps west and south from the northeast corner of the rectangle to the southwest corner (where the \swarrow indicates that the path “goes southwest”). If we label the steps of the lattice path from 1 to n , then the labels of the south steps give a k -element subset of $[n]$ that we denote by $V^\swarrow(\lambda)$ (the “vertical steps” of λ). Conversely, each k -element subset I of $[n]$ can be identified with a Young diagram, which we denote by $\lambda^\swarrow(I)$. Since this gives a bijection between Young diagrams contained in a $k \times (n-k)$ rectangle and k -element subsets of $[n]$, we also index Schubert and opposite Schubert cells and varieties by Young diagrams, denoting them Ω_λ , Ω^λ , X_λ , and X^λ , respectively. The open Schubert and opposite Schubert varieties are denoted by X_λ° , and $(X^\lambda)^\circ$. The dimension of Ω_λ , X_λ , and X_λ° is $|\lambda|$, the number of boxes of λ , while the codimension of Ω^λ , X^λ , and $(X^\lambda)^\circ$ is $|\lambda|$.

Remark 3.1.3. Throughout this chapter we will be primarily working with open Schubert (and skew-Schubert) varieties. The reader should be cautioned that we will mostly drop the adjective “open” from now on but will try to consistently use the notation X_λ° for clarity.

We also associate with a Young diagram λ the *Grassmannian permutation* π_λ^\swarrow of type $(n-k, n)$: in list notation, this permutation is obtained by first reading the labels of the horizontal steps of L_λ^\swarrow , and then reading the labels of the vertical steps of L_λ^\swarrow . (Moreover any fixed points in positions $1, 2, \dots, n-k$ are “black” and any fixed points in positions $n-k+1, \dots, n$ are “white.”) Note that $\ell(\pi_\lambda^\swarrow) = |\lambda|$.

Remark 3.1.4. The open positroid varieties $\pi_k(\mathcal{R}_{v,w}) \subseteq Gr_{k,n}$ are in bijection with a variety of combinatorial objects introduced by Postnikov in [41], including decorated permutations (see Definition 2.2.4) on n letters with k *antiexcedances*. Here we say that $i \in [n]$ is an *antiexcedance* if $\pi_{v,w}^{-1}(i) > \pi_{v,w}(i)$ or i is a white lollipop.

As pointed out in [49], the decorated permutation corresponding to $\pi_k(\mathcal{R}_{v,w})$ is $\pi_{v,w} := v^{-1}w$ with all white fixed points lying in $v^{-1}([k])$ (see [26, Section 2.4, Equation 2.27] for phrasing that is closer to ours). The set of antiexcedances is exactly $v^{-1}([k])$. Clearly one can recover the pair (v, w) from $\pi_{v,w}$ since $v \in W_{\max}^K$.

Remark 3.1.5. “Going northeast” along the lattice path L_λ^\swarrow gives rise to analogous bijections between Young diagrams in a $k \times (n-k)$ rectangle, k -element subsets of n , and Grassmannian permutations of type (k, n) . So we can define all the notations that we did before, switching each \swarrow to a \nearrow . So a Young diagram λ is identified with the lattice path L_λ^\nearrow in the rectangle taking steps east and north from the southwest corner of the rectangle to the northeast corner. If we label the path with 1 to n , the labels of the north steps give the k -element subset $V^\nearrow(\lambda)$. Similarly we define $\lambda^\nearrow(I)$.

The main result

We now state the main result. Note that the definitions of plabic graph and trip permutation can be found in Section 2.2.

Theorem 3.1.6. *Consider the Schubert variety X_λ° of $\text{Gr}(k, n)$. Let G be a reduced plabic graph (with boundary vertices labeled clockwise from 1 to n) with trip permutation π_λ^\leftarrow . Then the coordinate ring $\mathbb{C}[\tilde{X}_\lambda^\circ]$ of the (affine cone over) X_λ° coincides with the cluster algebra $\mathcal{A}(\Sigma_G^T)$.*

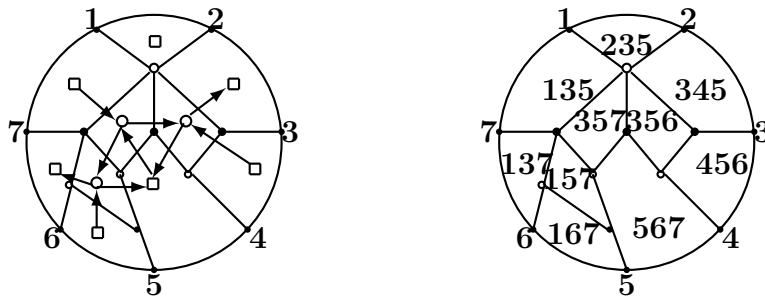

Figure 3.1: A plabic graph G for $\text{Gr}_{3,7}$ with trip permutation $\pi_\lambda^\leftarrow = 2467135$, for $\lambda = (4, 3, 2)$, together with the dual quiver of G and the face labeling given by target labels. The associated Le-diagram is a Young diagram of shape λ which is filled with $+$'s.

Theorem 3.1.6 can be rephrased as follows:

- Each of the (in general, infinitely many) cluster variables in $\mathcal{A}(\Sigma_G^T)$ is a regular function on \tilde{X}_λ° .
- The cluster variables in $\mathcal{A}(\Sigma_G^T)$ generate the ring $\mathbb{C}[\tilde{X}_\lambda^\circ]$ of regular functions on \tilde{X}_λ° .

We actually prove something a bit more general than Theorem 3.1.6; we prove the following.

Theorem 3.1.7. *Consider the skew Schubert variety $\pi_k(\mathcal{R}_{v,w})$, where $v \in W_{max}^K$ and w has a length-additive factorization $w = xv$. Let G be a reduced plabic graph (with boundary vertices labeled clockwise from 1 to n) with trip permutation $vw^{-1} = x^{-1}$, and such that boundary lollipops are white if and only if they are in $[k]$. Apply v^{-1} to the boundary vertices of G , obtaining the relabeled graph $G^{v^{-1}}$, and apply the target labeling to obtain the labeled seed $\Sigma_{G^{v^{-1}}}^T$. Then the coordinate ring $\mathbb{C}[\pi_k(\mathcal{R}_{v,w})]$ of the (affine cone over) the skew Schubert variety $\pi_k(\mathcal{R}_{v,w})$ coincides with the cluster algebra $\mathcal{A}(\Sigma_{G^{v^{-1}}}^T)$.*

In the case of Schubert varieties, Theorem 3.1.6 resolves Conjecture 1.0.1, which has been believed to be true by experts for some time, though it wasn't written down explicitly as

a conjecture until recently, see [36, Conjecture 3.4]. Note that there is another version of the conjecture which uses the *source labeling* of G instead of the target labeling [36, Remark 3.5]. Both conjectures make sense more generally for positroid varieties and arbitrary reduced plabic graphs (whose trip permutations can be arbitrary decorated permutations). However, the cluster structure that we give in Theorem 3.1.7 is different from either of the cluster structures proposed in [36].

Our strategy of proof is to find, for each skew Schubert variety, one distinguished seed coming from Leclerc’s cluster structure, which we can describe completely explicitly. We then show that this seed agrees with a corresponding seed coming from the combinatorial construction of Theorem 3.1.7, and justify that mutations in both cluster structures agree. We use a (modification) of a construction of Karpman [26] as a key tool in the proof.

Remark 3.1.8. In his thesis [9], Chevalier describes a cluster-tilting object associated to Richardson varieties $\mathcal{R}_{v,w}$ where $v = w_K$ and $w \geq v$ in Bruhat order. These Richardson varieties correspond to positroid varieties in $\text{Gr}(k, n)$ whose \mathbb{J} -diagrams have shape $k \times (n - k)$. (This case is somewhat complementary to the cases that we consider in this chapter, in the sense that Chevalier treats \mathbb{J} -diagrams of shape $k \times (n - k)$ with arbitrary fillings, while on the other hand Schubert varieties correspond to \mathbb{J} -diagrams of arbitrary shape whose boxes are all filled with +’s.) In the case of the big open Schubert variety in the Grassmannian (i.e. the positroid whose \mathbb{J} -diagram is a $k \times (n - k)$ rectangle filled with all +’s) we get the same quiver as Chevalier does, but different modules (and hence different Plücker coordinates). And in other cases of overlap (i.e. skew-Schubert varieties with $v = w_K$) even our quivers are different from Chevalier’s.

Outline of the chapter

This chapter is structured as follows. In Section 3.2, we recall a necessary lemma on reduced expressions. While each skew Schubert variety $\pi_k(\mathcal{R}_{v,w})$ (where $v = w_K v' \in W_{max}^K$ and $w \in W$ has a length-additive factorization $\mathbf{w} = \mathbf{xv} = \mathbf{xw_K v'}$ into reduced expressions for x , w_K , and v') corresponds to an equivalence class of plabic graphs (more generally to a collection of cluster seeds), there is one among them which is particularly nice, which we call the *rectangles seed*. In Section 3.3, we give an explicit description of the rectangles seed for a skew Schubert variety $\pi_k(\mathcal{R}_{v,w})$ as above, together with its dual cluster quiver. In Section 3.4 we describe a construction of Karpman [26] which produces a bridge-decomposable plabic graph associated to a pair (y, \mathbf{z}) , where $y^{-1} \in W_{max}^K$, \mathbf{z} is a reduced decomposition for z , and $y \leq z$. And we show that if we perform her construction for the pair $(w_K, \mathbf{xw_K})$ and then relabel boundary vertices of the resulting plabic graph G by v^{-1} , the target labeling of the dual quiver of G gives rise to the rectangles seed for $\pi_k(\mathcal{R}_{v,w})$. In Section 3.5 we describe a construction of Leclerc [30], which produces a cluster seed associated to each pair (v, \mathbf{w}) , where $v \in W_{max}^K$ and $v \leq w$. We also prove that for the choice $(v, \mathbf{w} = \mathbf{xw_K v'}$), Leclerc’s construction gives rise to the rectangles seed. In Section 3.6, we build on the results of the previous sections to prove Theorem 3.1.7 and then deduce Theorem 3.1.6 from it. Section 3.7

1	5	8	10
2	6	9	11
3	7		
4			

s_4	s_5	s_6	s_7
s_3	s_4	s_5	s_6
s_2	s_3		
s_1			

Figure 3.2: Let $x = (2, 4, 7, 8, 1, 3, 5, 6) \in {}^K W$, and $\lambda^\rceil(x([k])) = (4, 4, 2, 1)$. On the left, the *columnar* reading order for the boxes of $\lambda^\rceil(x([k]))$; on the right, the filling of $\lambda^\rceil(x([k]))$ with simple transpositions. This reading order produces the reduced expression $\mathbf{x} = s_6 s_7 s_5 s_6 s_3 s_4 s_5 s_1 s_2 s_3 s_4$ for $x \in {}^K W$, and the reduced expression $s_4 s_3 s_2 s_1 s_5 s_4 s_3 s_6 s_5 s_7 s_6$ for $x^{-1} \in W^K$.

gives applications of Theorem 3.1.6 and Theorem 3.1.7, and characterizes for which Schubert varieties the cluster structure is of finite type. In Section 3.8, we give a concrete description of skew Schubert varieties. And in Section 3.9, we give an example showing that outside of the skew-Schubert case, the cluster subalgebra of the coordinate ring of $\pi_k(\mathcal{R}_{v,w})$ coming from Leclerc’s construction is in general impossible to realize from a plabic graph.

3.2 A lemma on reduced expressions

We will need the following lemma on reduced expressions for permutations in ${}^K W$ and W^K . It is illustrated in Figure 3.2.

Lemma 3.2.1. [48] *Let $x \in {}^K W$ and let $\lambda := \lambda^\rceil(x([k]))$. Choose a “reading order” for the boxes of λ such that each box is read before the box immediately below it and the box immediately to its right (that is, choose a standard Young tableaux of shape λ). Fill each box with a simple transposition; the box in row r and column c is filled with s_{k-c+r} . Then reading the fillings of the boxes according to the reading order gives a reduced expression for x (written from right to left).*

Since the elements of W^K are just the inverses of the elements of ${}^K W$, one can also obtain reduced expressions for $y \in W^K$ by the process described in Lemma 3.2.1, using the partition $\lambda^\rceil(y^{-1}([k]))$. The only difference is the resulting reduced expression for y is written down from left to right.

Remark 3.2.2. For simplicity, we will always use the *columnar* reading order, which reads the columns of λ from top to bottom, moving left to right (see Figure 3.2). We will call the resulting reduced expressions *columnar expressions*.

We will be particularly concerned with pairs (v, w) where $v \in W_{\max}^K$ and w has a *length-additive factorization* $w = xv$, i.e. $\ell(w) = \ell(x) + \ell(v)$. We will often use reduced expressions for such permutations w that reflect their length-additive factorizations.

Definition 3.2.3. Let $v \leq w$, with $v \in W_{\max}^K$ and $w = xv$ length-additive. Let $v = w_K v'$ be length-additive, where v' is necessarily in W_{\min}^K . Then a *standard reduced expression* for w is a reduced expression $\mathbf{w} = \mathbf{x} \mathbf{w}_K \mathbf{v}'$, where \mathbf{x} and \mathbf{v}' are the columnar expressions for x and v' , respectively, and \mathbf{w}_K is an arbitrary reduced expression for w_K .

3.3 The rectangles seed associated to a skew Schubert variety

Definition 3.3.1 explains how to associate to a pair of permutations a quiver whose vertices are labeled by Plücker coordinates. The construction is illustrated in Figure 3.3.

Definition 3.3.1 (*The rectangles seed $\Sigma_{v,w}$*). Let $v \leq w$, where $v \in W_{\max}^K$ and $w = xv$ is a length-additive factorization. Let $\lambda := \lambda^{\nearrow}(x([k]))$. If b is a box of λ , let $\text{Rect}(b)$ be the largest rectangle contained in λ whose lower right corner is b .

We obtain a quiver $Q_{v,w}$ as follows: place one vertex in each box of λ . A vertex is mutable if it lies in a box b of the Young diagram and the box immediately southeast of b is also in λ . We add arrows between vertices in adjacent boxes, with all arrows pointing either up or to the left. Finally, in every 2×2 rectangle in λ , we add an arrow from the upper left box to the lower right box. Equivalently, we add an arrow from the vertex in box a to the vertex in box b if

- $\text{Rect}(b)$ is obtained from $\text{Rect}(a)$ by removing a row or column.
- $\text{Rect}(b)$ is obtained from $\text{Rect}(a)$ by adding a hook shape.

We then remove all arrows between two frozen vertices.

To obtain the *rectangles seed* $\Sigma_{v,w}$, we label each vertex of $Q_{v,w}$ with a Plücker coordinate. For b a box of λ , let $J(b) := V^{\nearrow}(\text{Rect}(b))$. The label of the vertex in b is $\Delta_{v^{-1}(J(b))}$. This labeled quiver $\Sigma_{v,w}$ gives a seed as in Definition 2.1.3, where the Plücker coordinates labeling the vertices give the extended cluster.

Definition 3.3.2. Let λ be a partition and let b be a box of λ . We say that $\text{Rect}(b)$ is *frozen for λ* or *λ -frozen* if b touches the south or east boundary of λ (either along an edge or at the southeast corner).

Note that the λ -frozen rectangles correspond to the frozen vertices of $\Sigma_{v,w}$.

Proposition 3.3.3. Let $\pi_k(\mathcal{R}_{v,w})$ be a skew Schubert variety. Then the rectangles seed $\Sigma_{v,w}$ is a seed for a cluster structure on the coordinate ring of (the affine cone over) $\pi_k(\mathcal{R}_{v,w})$, i.e. $\mathbb{C}[\pi_k(\overline{\mathcal{R}_{v,w}})] = \mathcal{A}(\Sigma_{v,w})$.

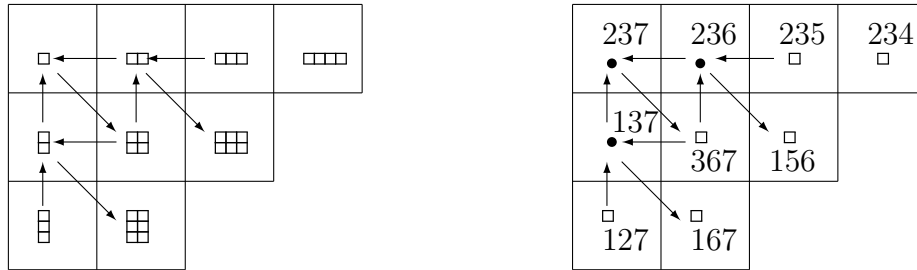

Figure 3.3: An example of $\Sigma_{v,w}$ for $k = 3$, $n = 7$, $v = w_K$ and $x = wv^{-1} = (3, 5, 7, 1, 2, 4, 6)$. At the left, the λ -frozen rectangles are $\square\square\square$, $\square\square$, $\square\square$, \square , \square , \square . On the right, the same quiver is shown but rectangles have been replaced by the corresponding 3-element subsets of $[7]$, which should be interpreted as Plücker coordinates.

This result follows as an immediate corollary from Theorem 3.5.20, whose proof is the focus of Section 3.5.

In the following section, we discuss the relabeled plabic graph whose dual quiver (with the target labeling) coincides with $\Sigma_{v,w}$, as well as the connections of this theorem to Conjecture 1.0.1.

Recall that if $v \in W_{max}^K$ and $\lambda = \lambda^\vee(v^{-1}([k]))$, then $\pi_k(\mathcal{R}_{v,w_0})$ is the open Schubert variety X_λ° . So as an immediate corollary to this result, we obtain the following.

Corollary 3.3.4. *Let $v \in W_{max}^K$ and let $\lambda := \lambda^\vee(v^{-1}([k]))$. Then the rectangles seed Σ_{v,w_0} is a seed for the cluster structure on X_λ° , i.e. $\mathbb{C}[X_\lambda^\circ] = \mathcal{A}(\Sigma_{v,w_0})$.*

3.4 Obtaining the rectangles seed from a bridge graph

Here we give a construction of a special kind of plabic graph – a *bridge graph* – from a pair of permutations [26], and explain how to use this construction to produce the rectangles seed.

Bridge graphs

One can obtain a plabic graph with arbitrary trip permutation by successively adding “bridges” (see Figure 3.4) to a graph consisting entirely of lollipops. The plabic graphs created this way are *bridge graphs*. We will define them below, after reviewing the notion of (bounded) affine permutations.

An *affine permutation* of order n is a bijection $f : \mathbb{Z} \rightarrow \mathbb{Z}$ such that $f(i+n) = f(i) + n$ for all $i \in \mathbb{Z}$.

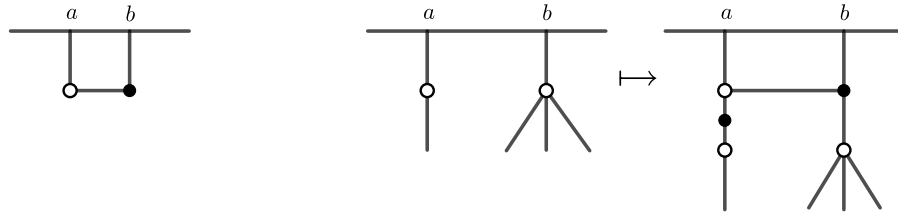

Figure 3.4: On the left, an $(a b)$ -bridge. On the right, an example of adding an $(a b)$ -bridge to a plabic graph.

Definition 3.4.1. If σ is a decorated permutation of $[n]$, we define the bounded affine permutation $\tilde{\sigma}$ on $[n]$ as

$$\tilde{\sigma}(i) := \begin{cases} \sigma(i) & \text{if } \sigma(i) > i \text{ or } i \text{ is a black fixed point} \\ \sigma(i) + n & \text{if } \sigma(i) < i \text{ or } i \text{ is a white fixed point} \end{cases}$$

and extend periodically to \mathbb{Z} . In other words, to obtain a bounded affine permutation, add n to all antiexcedances of σ and then extend periodically to \mathbb{Z} .

An $(a b)$ -bridge is a collection of two vertices and three edges inserted at boundary vertices a and b as in the left of Figure 3.4. Let G be a plabic graph with (bounded affine) trip permutation $\tilde{\sigma}_G$. For a pair of boundary vertices $a < b$, we say that the $(a b)$ -bridge is *valid* if $\tilde{\sigma}_G(a) > \tilde{\sigma}_G(b)$, all boundary vertices c between a and b are lollipops, and if a (resp. b) is a lollipop it is white (resp. black).

To add a bridge to G , choose boundary vertices a, b such that the $(a b)$ -bridge is valid. Place a white (resp. black) vertex in the middle of the edge adjacent to a (resp. b) and put an edge between these two vertices; if a (resp. b) is a lollipop, we use the boundary leaf as the white (resp. black) vertex of the bridge. We then add degree two vertices as necessary to make the resulting graph bipartite. A plabic graph obtained by successively adding valid bridges to a lollipop graph is called a *bridge graph*.

Adding a bridge changes the trip permutation in a predictable way.

Lemma 3.4.2 ([26, Proposition 2.5]). *Suppose G is a reduced plabic graph with (bounded affine) trip permutation $\tilde{\sigma}_G$. Let $1 \leq a < b \leq n$ be vertices such that the $(a b)$ -bridge is valid and let G' be the plabic graph obtained by adding an $(a b)$ -bridge to G . Then G' is reduced and has trip permutation $\tilde{\sigma}_G \circ (a b)$.*

Remark 3.4.3. Let G_0 be a lollipop graph, $(a_1 b_1), \dots, (a_r b_r)$ a sequence of bridges, and G_i the graph obtained from adding bridge $(a_i b_i)$ to G_{i-1} . We also assume that $(a_i b_i)$ is a valid bridge for G_{i-1} . In the construction given above, new bridges are always added at the boundary and “push” the existing faces towards the center of the disk (see Example 3.4.7).

One can also obtain G_r from an empty graph by adding bridges in the opposite order, placing new bridges “below” existing bridges, and adding lollipops at the end if necessary. We will always use the former algorithm, but the latter can be useful as well.

If G' is obtained from a plabic graph G by adding a valid bridge, all faces of G' correspond to faces in G , except for the face bounded by the bridge.

Lemma 3.4.4. *Suppose G is a reduced plabic graph, $1 \leq a < b \leq n$ vertices such that the $(a \ b)$ -bridge is valid, and G' the plabic graph resulting from adding an $(a \ b)$ -bridge to G . Then, using the target labeling, the labels of faces in G coincide with the labels of corresponding faces in G' .*

It is not hard to find the (target) label of the remaining face of G' .

Definition 3.4.5. Let σ be a decorated permutation of $[n]$. The *Grassmann necklace* of σ is a sequence $\mathcal{J} = (J_1, J_2, \dots, J_n)$ of subsets of $[n]$ where $J_1 := \{i \in [n] \mid \sigma^{-1}(i) > i \text{ or } i \text{ is a white fixed point}\}$ and

$$J_{i+1} := \begin{cases} (J_i \setminus \{i\}) \cup \{\sigma(i)\} & \text{if } i \in J_i \\ J_i & \text{else.} \end{cases}$$

If $\sigma_{G'}$ is the trip permutation of G' , the boundary faces of G' are labeled with the Grassmann necklace of $\sigma_{G'}$ [39]. So the label of the face bounded by the $(a \ b)$ -bridge is just the $(a + 1)^{st}$ entry of the Grassmann necklace of $\sigma_{G'}$.

Bridge graphs from pairs of permutations

In [26], Karpman gives an algorithm for producing a bridge graph with trip permutation vw^{-1} from a pair (v, \mathbf{w}) , where $v^{-1} \in W_{\max}^K$ and \mathbf{w} is a reduced expression for some permutation $w \geq v$. We use a special case of her construction in the following definition.

Definition 3.4.6. Let $w \in W$ with a length-additive factorization $w = xw_K$, where $x \in {}^K W$. Let $\mathbf{x} = s_{i_r} \dots s_{i_1}$ be the columnar expression for x (see Remark 3.2.2) and let \mathbf{w} be a standard reduced expression for w (Definition 3.2.3). We define $B_{w_K, \mathbf{w}}$ to be the bridge graph obtained from the lollipop graph with white lollipops $[k]$ and black lollipops $[k + 1, n]$ with bridge sequence $s_{i_1}, s_{i_2}, \dots, s_{i_r}$.

By [26], $B_{w_K, \mathbf{w}}$ is a reduced plabic graph. By Lemma 3.4.2, $B_{w_K, \mathbf{w}}$ has (decorated) trip permutation x^{-1} with fixed points in $[k]$ colored white.

Example 3.4.7. Let $k = 2$, $n = 5$, $x = (3, 5, 1, 2, 4)$ and $w = xw_K$. The partition $\lambda^\vee(x([2]))$ corresponding to $x([2]) = \{x(1), x(2)\}$ is $(3, 2)$, and the columnar expression for x is $\mathbf{x} = s_4 s_2 s_3 s_1 s_2$. So the bridge sequence for $B_{w_K, \mathbf{w}}$ is $(2 \ 3), (1 \ 2), (3 \ 4), (2 \ 3), (4 \ 5)$. To build $B_{w_K, \mathbf{w}}$, we start with the lollipop graph

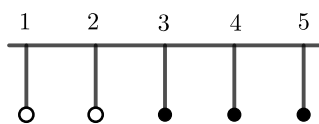

then add the bridge (2 3),

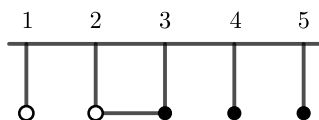

the bridge (1 2),

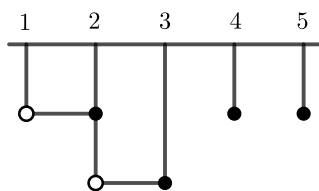

and the bridges (3 4), (2 3), (4 5) to obtain the following graph.

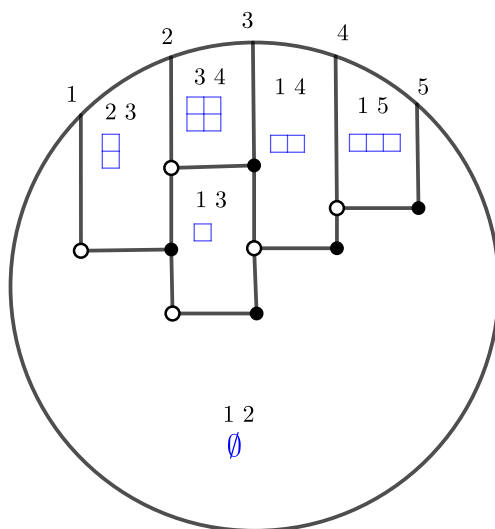

Note that the (target) face labels of $B_{w_K, w}$ correspond to rectangles that fit inside of $\lambda^\vee(x([2]))$.

The structure of $B_{w_K, \mathbf{w}}$ will follow entirely from the structure of its Grassmann necklace. First, we need the following simple lemma.

Lemma 3.4.8. *Let $x \in {}^K W$.*

1. *The fixed points of x are $[p] \cup [q, n]$ for some $0 \leq p \leq k < q \leq n + 1$.*
2. *For $i \in [k]$, $x(i) \geq i$.*

Proof. For the first statement, recall that $x \in {}^K W$ implies $x(1) < x(2) < \dots < x(k)$ and $x(k+1) < \dots < x(n)$. Suppose $x(j) = j$ for some $j \in [k]$. Since for $i < j$, $x(i) < x(j)$, we must have that $x([j]) = [j]$. The increasing condition described above then implies that $x(i) = i$ for $i < j$. An analogous argument shows that if $x(j) = j$ for some $j \in [k+1, n]$, then $x(\ell) = \ell$ for all $\ell > j$.

The second statement is clear from the condition that $x(1) < x(2) < \dots < x(k)$. \square

Proposition 3.4.9 shows that the Young diagrams associated to the Grassmann necklace of $y \in W_{\min}^K$ are the rectangles which are frozen for $\lambda := \lambda^\rceil(y^{-1}[k])$ (cf Definition 3.3.2), together with \emptyset .

Proposition 3.4.9. *Let $y \in W_{\min}^K$ with fixed points $[p] \cup [q, n]$, and let $\lambda := \lambda^\rceil(y^{-1}[k])$. We color the fixed points of y in $[k]$ white and all others black. Let $\mathcal{J} = (J_1, \dots, J_n)$ be the Grassmann necklace of y . Then $\lambda^\rceil(J_i) = \emptyset$ for $i \in [p+1] \cup [q, n]$. For other i , $\lambda^\rceil(J_i)$ is a rectangle which is frozen for λ , and $\lambda^\rceil(J_{i+1})$ can be obtained from $\lambda^\rceil(J_i)$ by adding a column to $\lambda^\rceil(J_i)$ if the resulting rectangle fits inside of λ (that is, if $y(i) > k$) or removing a row from $\lambda^\rceil(J_i)$ if it does not (that is, if $y(i) \leq k$). In particular, every λ -frozen rectangle occurs as one of the $\lambda^\rceil(J_i)$.*

Proof. We induct on the length of y . If $y = e$, the white fixed points of y are $[k]$, so $J_i = [k]$ for all i , corresponding to the empty set.

Now, consider $y \neq e$. Note that by Lemma 3.4.8, if $i \in [k]$ is not a fixed point of y , then $y^{-1}(i) > i$. This together with our choice of decoration implies that the antiexcedance set of y is $[k]$.

Suppose the columnar expression for y ends in s_j . Then $z := ys_j$ is an element of W^K corresponding to the partition $\lambda' := \lambda^\rceil(z^{-1}([k]))$, which is λ with the bottom box of the rightmost column removed. In other words, in λ , the j^{th} step is horizontal and the $(j+1)^{\text{th}}$ step is vertical, and vice versa in λ' . Again, we color the fixed points of z in $[k]$ white and the fixed points in $[k+1, n]$ black, and let $\mathcal{I} = (I_1, \dots, I_n)$ be the Grassmann necklace of z .

Note that $J_r = I_r$ for $r \leq j$, since the antiexcedances of both permutations are $[k]$ and $y(r) = z(r)$ for $r \neq j, j+1$. Note also that since $\ell(y) > \ell(z)$, $y(j) > y(j+1)$. As y is a minimum length right coset representative, this implies $y(j) > k \geq y(j+1)$. From this, we can conclude neither j nor $j+1$ are fixed by y ; otherwise, Lemma 3.4.8 would lead to a contradiction. So $J_{j+1} = (I_j \setminus \{j\}) \cup \{y(j)\}$ and $J_{j+2} = (J_{j+1} \setminus \{j+1\}) \cup \{y(j+1)\}$.

By definition, $z(j+1) > k \geq z(j)$. By induction, $\lambda^\rceil(I_j)$ is a rectangle, so $I_j = [a] \cup [b, c]$ for $0 \leq a \leq b, c \leq n$. There are 4 cases, depending on if j or $j+1$ is fixed by z . The cases in which at least one of j and $j+1$ is fixed are straightforward, so we just prove the last.

Suppose neither j nor $j+1$ are fixed by z , so λ' is obtained from λ by removing a box that is not in the left column or top row. Suppose $I_j = [a] \cup [b, c]$. Since $z(j) \leq k$, $\lambda^\rceil(I_{j+1})$ is obtained from $\lambda^\rceil(I_j)$ by removing a row, and we have that $I_{j+1} = [a+1] \cup [b+1, c]$. In other words, $j = b$ and $z(j) = a+1$. $\lambda^\rceil(I_{j+2})$ is obtained from $\lambda^\rceil(I_{j+1})$ by adding a column, so $I_{j+2} = [a+1] \cup [b+2, c+1]$; that is, $z(j+1) = c+1$. So $J_{j+1} = [a] \cup [b+1, c+1]$, which means that $\lambda^\rceil(J_{j+1})$ is the rectangle obtained from $\lambda^\rceil(J_j)$ by adding a column. This rectangle fits inside of λ because of where we added a box and is also λ -frozen, since its lower right corner touches the southeastern boundary of λ . Computation shows that $J_{j+2} = I_{j+2}$, and thus $\lambda^\rceil(J_{j+2})$ is obtained from $\lambda^\rceil(J_{j+1})$ by removing a row. Since $I_r = J_r$ for $r \neq j+1$, and all of the rectangles $\lambda^\rceil(I_r)$ are λ -frozen for $r \neq j+1$, we are done. \square

As a corollary, we obtain the structure of the face labels of the plabic graphs we are interested in.

Corollary 3.4.10. *Let $w \in W$ with a length-additive factorization $w = xw_K$, where $x \in KW$. Let $\mathbf{x} = s_{i_r} \dots s_{i_1}$ be the columnar expression for x and \mathbf{w} be a standard reduced expression for w . Let $\lambda := \lambda^\rceil(x([k]))$. Then the set of face labels of $B_{w_K, \mathbf{w}}$ (see Definition 3.4.6) with respect to the target labeling is $\{V^\rceil(\text{Rect}(b)) \mid b \text{ a box of } \lambda\} \cup \{V^\rceil(\emptyset)\}$. The boundary face labels correspond to the λ -frozen rectangles and the empty set.*

Proof. Recall that the bridge sequence of $B_{w_K, \mathbf{w}}$ is exactly the simple transpositions in the columnar expression for x^{-1} ; that is s_{i_1}, \dots, s_{i_r} . After placing the j^{th} bridge, we get a plabic graph with trip permutation $s_{i_1} \dots s_{i_j}$ with fixed points in $[k]$ colored white. Since $s_{i_1} \dots s_{i_j} \in W_{\min}^K$, by Proposition 3.4.9, its Grassmann necklace consists of rectangles that are frozen for the partition corresponding to $s_{i_1} \dots s_{i_j}$. The face labels of the boundary faces are the Grassmann necklace of the trip permutation, with I_j labeling the face immediately to the left of j . When we add the $(j+1)^{\text{th}}$ bridge, we introduce a new boundary face (whose label is a rectangle that is frozen for the partition corresponding to $s_{i_1} \dots s_{i_{j+1}}$) and the labels of all other faces stay the same. An old boundary face may be pushed off of the boundary by the new face; this occurs precisely when its label is not frozen for the new partition. Further, it is clear that every rectangle that fits into λ is frozen for a partition corresponding to some prefix of $s_{i_1} \dots s_{i_r}$. \square

We can also describe the dual quiver of $B_{w_K, \mathbf{w}}$.

Proposition 3.4.11. *Let w, x , and \mathbf{w} be as in Corollary 3.4.10, and let $\lambda := \lambda^\rceil(x([k]))$. Let μ, ν be rectangles contained in λ which are not the empty partition. In the dual quiver of $B_{w_K, \mathbf{w}}$, there is an arrow from the face labeled $V^\rceil(\mu)$ to the face labeled $V^\rceil(\nu)$ if*

- ν is obtained from μ by removing a row or column

- ν is obtained from μ by adding a hook shape

unless both faces are on the boundary, in which case there is no arrow between them. There is also an arrow from the face labeled $V^\vee(\mu)$, where μ is a single box, to the face labeled $[k]$.

Proof. This follows from the proof of Corollary 3.4.10 by induction on the number of bridges.

To make the proof more uniform, we color all boundary vertices of $B_{w_K, \mathbf{w}}$ adjacent to white (black) internal vertices black (white) and add arrows appropriately in the dual quiver. To obtain the statement of the proposition, just remove all arrows between frozen vertices.

Let $\mathbf{x} = s_{i_r} \dots s_{i_1}$ be the columnar expression for x , so that s_{i_1}, \dots, s_{i_r} is the bridge sequence for $B_{w_K, \mathbf{w}}$. Note that $s_{i_1} = s_k$.

If there is only one single bridge, then $B_{w_K, \mathbf{w}}$ has two faces, one face f labeled with $[k] = V^\vee(\emptyset)$ and the other face f' labeled with $V^\vee(\mu)$, where μ is a single box. From the coloring of vertices in a bridge, it is clear that the dual quiver has one arrow from f' to f .

We examine what occurs after we place the final bridge $s_{i_r} = (j \ j+1)$. Let f' be the new face created by this bridge. Note that j and $j+1$ cannot both be lollipops. Indeed, it is easy to see from the definition of the columnar reading order for λ that s_{i_r} is preceded by either a s_{i_r-1} or a s_{i_r+1} in the bridge sequence. If j or $j+1$ is a lollipop, then the face f' shares 2 edges with f , the face labeled with $[k]$. This means there are no edges between these faces in the dual quiver, since 2 shared edges results in an oriented 2-cycle.

Note also that we do not have to add additional vertices of degree 2 after placing the bridge to make the graph bipartite; this is clear from the previous paragraph if j or $j+1$ is a lollipop. If neither is a lollipop, from the columnar reading order, it is clear that there is a s_{j-1} and a s_{j+1} between each occurrence of s_j in the sequence s_{i_1}, \dots, s_{i_r} , so j is adjacent to a black internal vertex and $j+1$ is adjacent to a white internal vertex. This means that there is an arrow in the dual quiver between f' and all adjacent faces that are not labeled with $[k]$. We discuss these arrows in the case when neither j nor $j+1$ are lollipops, as the other cases are similar.

We know that f' is labeled by (the vertical steps of) $\text{Rect}(b)$, where b is the last box of λ in the columnar reading order. According to the proof of Corollary 3.4.10, to its right is the face labeled by (the vertical steps of) a partition ν obtained from $\text{Rect}(b)$ by removing a row (since the partition obtained from $\text{Rect}(b)$ by adding a column does not fit in λ). Similarly, to the left of f' is the face labeled by (the vertical steps of) a partition ν' obtained from $\text{Rect}(b)$ by removing a column. Below f' is the face labeled by the partition obtained from $\text{Rect}(b)$ by removing a hook shape. This, together with the color of vertices in bridges, gives the proposition. □

Obtaining the rectangles seed from a plabic graph

The goal of this section is to verify Lemma 3.4.12, which will be used in Section 3.6 to deduce Theorem 3.1.6 from Theorem 3.1.7.

In what follows, when we say “reflect a (relabelled) plabic graph in the mirror”, we mean the operation shown in Figure 3.5.

Now, we return to the setup of Section 3.3.

Lemma 3.4.12. *Let $v \leq w$ where $v \in W_{\max}^K$ and $w = xv$ is length-additive and let \mathbf{w}' be a standard reduced expression for xw_K . Consider the following relabelled plabic graphs, with the indicated face labeling.*

1. $G_{v,w}$, obtained by applying v^{-1} to the boundary vertices of $B_{w_K, \mathbf{w}'}$, with target labels.
2. $G_{v,w}^{\text{mir}}$, obtained by applying v^{-1} to the boundary vertices of $B_{w_K, \mathbf{w}'}$ and reflecting in the mirror, with source labels.
3. $H_{v,w}$, obtained by applying w^{-1} to the boundary vertices of $B_{w_K, \mathbf{w}'}$, with source labels.
4. $H_{v,w}^{\text{mir}}$, obtained by applying w^{-1} to the boundary vertices of $B_{w_K, \mathbf{w}'}$ and reflecting in the mirror, with target labels.

The labeled dual quiver of each of these graphs, with the vertex labeled $v^{-1}([k])$ deleted, is $\Sigma_{v,w}$ (up to reversing all arrows).

Proof. Clearly $G_{v,w}$ and $H_{v,w}$ have the same (unlabeled) dual quiver as $B_{w_K, \mathbf{w}'}$; reflecting in the mirror reverses all arrows in the dual quiver. By Proposition 3.4.11, the dual quiver of all of these graphs is $Q_{v,w}$ (see Definition 3.3.1), up to reversal of all arrows.

Since the face labels of $G_{v,w}$ are obtained from those of $B_{w_K, \mathbf{w}'}$ by applying v^{-1} , it is clear from Corollary 3.4.10 that the labeled dual quiver of $G_{v,w}$ is $\Sigma_{v,w}$. So it suffices to show that the face labels of $G_{v,w}$ agree with the face labels of the 3 other graphs.

Recall that the trip permutation of $B_{w_K, \mathbf{w}'}$ is x^{-1} . This implies that applying v^{-1} to a target face label of $B_{w_K, \mathbf{w}'}$ gives the same set as applying $v^{-1}x^{-1} = w^{-1}$ to a source face label of $B_{w_K, \mathbf{w}'}$. Thus the face labels of $H_{v,w}$ are the same as the face labels of $G_{v,w}$.

Note that reflecting a relabelled plabic graph in the mirror reverses all trips and also exchanges left and right. As a result, the target labels of $G_{v,w}$ are the same as the source labels of $G_{v,w}^{\text{mir}}$, and the source labels of $H_{v,w}$ are the same as the target labels of $H_{v,w}^{\text{mir}}$. □

Remark 3.4.13. Since we are actually interested in the affine cone over $\pi(\mathcal{R}_{v,w})$, we always assume that $\Delta_{v^{-1}([k])}$, the lexicographically minimal nonvanishing Plücker coordinate, is equal to 1. This is why we delete the vertex labeled by $v^{-1}([k])$ in Lemma 3.4.12.

Note that if $v = w_K$, $G_{v,w}^{\text{mir}}$ is a “usual” plabic graph (that is, its boundary vertices are $1, \dots, n$ going clockwise). Similarly, if $w = w_0$, $H_{v,w}^{\text{mir}}$ is a usual plabic graph. So in these cases, the rectangles seed $\Sigma_{v,w}$ gives rise to the cluster structure conjectured in [36, Conjecture 3.4]. In general, $\Sigma_{v,w}$ gives rise to a different cluster structure; the cluster variables may differ and the frozen variables generally do not agree with the labels of the boundary faces (with either

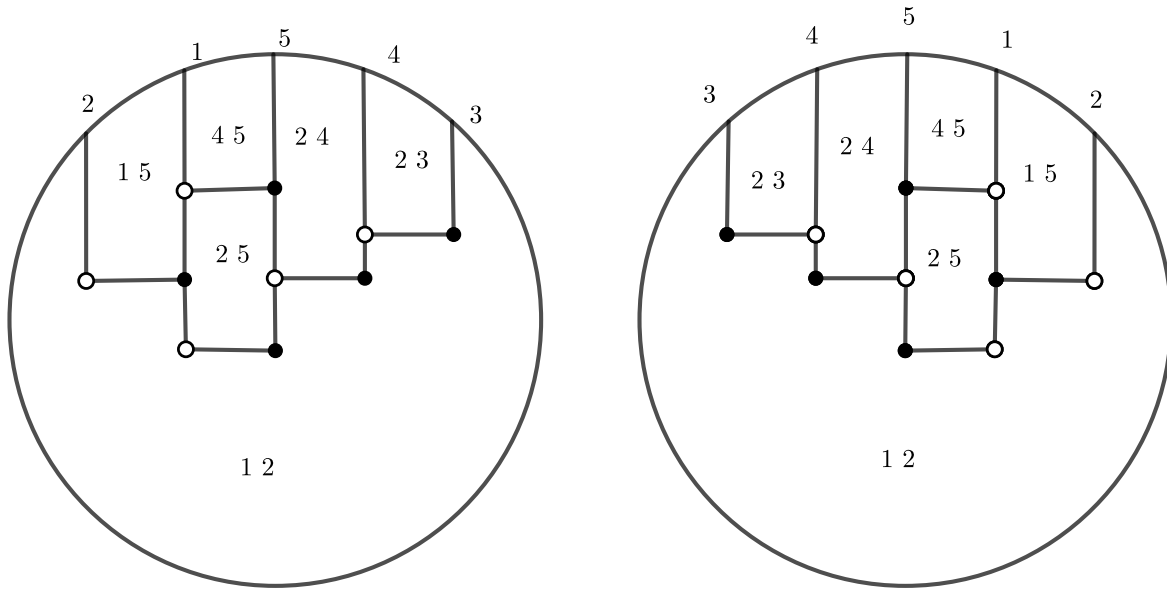

Figure 3.5: Let $k = 2$, $n = 5$, $x = (3, 5, 1, 2, 4)$ and $w = xw_K$ as in Example 3.4.7. On the left, we have applied w_K^{-1} to the boundary vertices of $B_{w_K, w}$ to obtain $G_{w_K, w}$ (shown with target labels). On the right, we have “reflected $G_{w_K, w}$ in the mirror” to obtain $G_{w_K, w}^{\text{mir}}$ (shown with source labels).

source or target labels) of a plabic graph corresponding to the positroid variety. However, the cluster structure given by $\Sigma_{v, w}$ is *quasi-isomorphic* to the cluster structure conjectured in [36, Conjecture 3.4]. This means roughly that seeds in one cluster algebra can be obtained from seeds in the other by rescaling variables by Laurent monomials in frozen variables, in a way that is compatible with mutation (see [17]). Details will appear in work in preparation by C. Fraser and the second author.

Remark 3.4.14. Applying v^{-1} or w^{-1} to the boundary vertices of $B_{w_K, w}$ is a mysterious operation. This relabeling takes a plabic graph associated to $\pi_k(\mathcal{R}_{w_K, w_K x^{-1}})$ to one associated to $\pi_k(\mathcal{R}_{v, xv})$, and hence these positroid varieties are isomorphic. We can describe the association of these two positroid varieties combinatorially in terms of \mathbb{J} -diagrams: to obtain the \mathbb{J} -diagram of $\pi_k(\mathcal{R}_{v, xv})$, rotate the \mathbb{J} -diagram of $\pi_k(\mathcal{R}_{e, x^{-1}})$ by 180° , cut off boxes so it has shape $\lambda^\vee(v^{-1}([k]))$, and then perform \mathbb{J} -moves until it satisfies the \mathbb{J} -property (see Section 3.8).

3.5 Obtaining the rectangles seed from Leclerc’s categorical cluster structure

The categorical cluster structure for Richardson varieties

We describe the categorical cluster structure on the coordinate ring of the Richardson variety $\mathcal{R}_{v,w}$ obtained in [30]. It involves representation theory of finite-dimensional algebras, see [1, 45] for some background. As we are only interested in the case of Grassmannians, we restrict our discussion to the construction in type A .

Let Λ be the *preprojective algebra* over \mathbb{C} of type A and rank $n - 1$. It is the finite-dimensional path algebra of the *double quiver*

$$\overline{Q} = 1 \begin{array}{c} \xrightarrow{\alpha_1} \\ \xleftarrow{\alpha_1^*} \end{array} 2 \begin{array}{c} \xrightarrow{\alpha_2} \\ \xleftarrow{\alpha_2^*} \end{array} 3 \begin{array}{c} \xrightarrow{\alpha_3} \\ \xleftarrow{\alpha_3^*} \end{array} \cdots \begin{array}{c} \xrightarrow{\alpha_4} \\ \xleftarrow{\alpha_4^*} \end{array} n - 1$$

on the vertex set $I = \{1, \dots, n - 1\}$, subject to the relations generated by

$$\sum_i \alpha_i \alpha_i^* - \alpha_i^* \alpha_i = 0.$$

In particular, the elements of Λ are linear combinations of paths in the quiver modulo the relations, and multiplication is given by concatenation of paths. Any finite-dimensional module N over Λ has an explicit realization in terms of the quiver. In particular, N is a collection $\{N_i\}_{i \in I}$ of finite-dimensional vector spaces over \mathbb{C} for each vertex $i \in I$, together with a collection of linear maps $\phi_\beta : N_i \rightarrow N_j$ for every arrow $\beta : i \rightarrow j$ in the quiver. Moreover, the composition of these linear maps must satisfy relations induced by the relations on the corresponding arrows.

Let $\text{mod } \Lambda$ be the category of finite-dimensional Λ -modules. For any $N \in \text{mod } \Lambda$ let $|N|$ be the number of pairwise non-isomorphic indecomposable direct summands of N . We use $\text{add } N$ to denote the additive closure of N , and $\text{ind } N$ to denote the set of indecomposable direct summands of N . Given a vertex i in the quiver \overline{Q} , let S_i denote the corresponding simple module and Q_i denote the associated injective module. The simple module S_i is obtained by placing \mathbb{C} , a one-dimensional vector space, at vertex i and 0’s at the remaining vertices of the quiver. In this case, $\phi_\beta = 0$ for all arrows β . On the other hand, the injective Λ -module Q_i also has a distinct structure, and we can represent Q_i by its composition factors as follows.

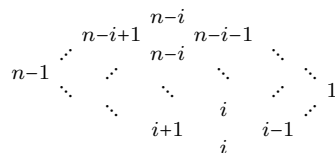

In particular, when $n = 6$ we obtain the following composition diagrams for the injective modules.

$$N \twoheadrightarrow S_i^a$$

where a is the multiplicity of S_i in the top of N . Note that $\mathcal{E}_i(N)$ is well-defined; it is obtained from N by removing the S_i -isotypical part of its top. Similarly, let $\mathcal{E}_i^\dagger(N)$ be the cokernel of an injection

$$S_i^b \hookrightarrow N$$

where b is the multiplicity of S_i in the socle of N . The module $\mathcal{E}_i^\dagger(N)$ results from N by taking away the S_i -isotypical part of its socle. In terms of the corresponding composition factor diagrams, the diagram for $\mathcal{E}_i(N)$ (resp. $\mathcal{E}_i^\dagger(N)$) is obtained from that of N by removing all entries i appearing in the top (resp. bottom). Moreover, for every $w \in W$ we can extend the definition to $\mathcal{E}_w, \mathcal{E}_w^\dagger$ by composing the functors associated to the simple reflections in a reduced expression for w . It was shown in [21, Proposition 5.1] that this definition does not depend on the choice of a reduced expression.

Given $w \in W$, consider $\mathcal{C}_w = \mathcal{E}_{w^{-1}w_0}(\text{mod } \Lambda)$ and $\mathcal{C}^w = \mathcal{E}_{w^{-1}}^\dagger(\text{mod } \Lambda)$, two subcategories of $\text{mod } \Lambda$ associated to w . With this notation we can summarize the main theorem of [30].

Theorem 3.5.1. [30, Theorem 4.5] *For every $v, w \in W$ with $v \leq w$, the subcategory $\mathcal{C}_{v,w} := \mathcal{C}^v \cap \mathcal{C}_w$ has a cluster structure in the sense of [5]. Moreover, $\mathcal{C}_{v,w}$ induces a cluster subalgebra $\tilde{R}_{v,w}$ in the coordinate ring $\mathbb{C}[\mathcal{R}_{v,w}]$, where the cardinality of the extended cluster is equal to $\dim \mathcal{R}_{v,w}$.*

Proposition 3.5.2. [30, Proposition 5.1] *If property (P) holds – that is, if w has a factorization of the form $w = xv$ with $\ell(w) = \ell(x) + \ell(v)$, then the cluster algebra $\tilde{R}_{v,w}$ is equal to the coordinate ring $\mathbb{C}[\mathcal{R}_{v,w}]$.*

In particular, the theorem says that $\mathcal{C}_{v,w}$ is a Frobenius category that admits a cluster-tilting object. Given a basic cluster-tilting module T we can associate the *endomorphism quiver* Γ_T as follows. The vertices of Γ_T are in bijection with indecomposable direct summands T_i of T . The number of arrows $T_i \rightarrow T_j$ in Γ_T corresponds to the dimension of the space of irreducible morphisms $T_i \rightarrow T_j$ in $\text{add } T$.

Given a basic cluster-tilting module $T \in \mathcal{C}_{v,w}$, there is a notion of mutation of T at an indecomposable summand T_i of T , provided that T_i is not projective-injective in $\mathcal{C}_{v,w}$. The *mutation* of T at T_i is a new cluster-tilting module $\mu_{T_i}(T) := T/T_i \oplus T'_i$, obtained by replacing T_i by a unique different indecomposable module $T'_i \in \mathcal{C}_{v,w}$. Moreover, T'_i is defined by the two short exact sequences

$$0 \longrightarrow T'_i \longrightarrow B \xrightarrow{g} T_i \longrightarrow 0 \qquad 0 \longrightarrow T_i \xrightarrow{f} B' \longrightarrow T'_i \longrightarrow 0$$

where g and f are minimal right and left $\text{add}(T/T_i)$ -approximations of T_i . Thus, B is a direct sum of $T_j \in \text{ind } T$ for every arrow $T_j \rightarrow T_i$ in Γ_T , and B' is a direct sum of $T_j \in \text{ind } T$ for every arrow $T_i \rightarrow T_j$ in Γ_T .

Furthermore, there is a cluster character $\varphi : \text{obj } \mathcal{C}_{v,w} \rightarrow \mathbb{C}[\mathcal{R}_{v,w}]$ that maps modules $N \in \mathcal{C}_{v,w}$ to functions $\varphi_N \in \mathbb{C}[\mathcal{R}_{v,w}]$. While the definition of φ is rather complicated, φ satisfies several nice properties. In particular, for every $N, N' \in \mathcal{C}_{v,w}$, we have

$$\varphi_{N \oplus N'} = \varphi_N \varphi_{N'}.$$

Moreover, for every mutation μ_{T_i} of a cluster-tilting module T , we obtain an exchange relation in $\mathbb{C}[\mathcal{R}_{v,w}]$:

$$\varphi_{T_i} \varphi_{T'_i} = \varphi_B + \varphi_{B'},$$

where B and B' come from the short exact sequences above. In this way the cluster character φ induces a cluster algebra structure in $\mathbb{C}[\mathcal{R}_{v,w}]$ from a categorical cluster structure in $\mathcal{C}_{v,w}$.

Next we want to give a more explicit version of Theorem 3.5.1.

Definition 3.5.3. Given $v \leq w$ in W and a reduced expression $\mathbf{w} = s_{i_t} \cdots s_{i_2} s_{i_1}$ for w , we construct a set of modules $\{U_j\}$ which will give rise to a cluster in $\mathbb{C}[\mathcal{R}_{v,w}]$. Let \mathbf{v} be the reduced subexpression for v in \mathbf{w} that is “rightmost” in \mathbf{w} , called the *positive distinguished subexpression* for v in \mathbf{w} (see Definition 3.9.1). Set $w_{(j)} = s_{i_j} \cdots s_{i_2} s_{i_1}$ for $1 \leq j \leq t$, and let $w_{(j)}^{-1} := (w_{(j)})^{-1}$. Let $v_{(j)}$ be the product of all simple reflections in $w_{(j)}$ that are part of \mathbf{v} . Define $J \subseteq \{1, \dots, t\}$ to be the collection of indices j such that the corresponding reflection s_{i_j} in the expression \mathbf{w} is *not* a part of \mathbf{v} .

For every $j \in J$ we construct a module U_j from the injective module Q_{i_j} . For $N \in \text{mod } \Lambda$ let $\text{Soc}_{s_i}(N)$ be the direct sum of all submodules of N isomorphic to the simple module S_i . Given a reduced word $z = s_{i_r} \dots s_{i_2} s_{i_1}$ in W , there is a unique sequence

$$0 = N_0 \subseteq N_1 \subseteq \dots \subseteq N_r \subseteq N$$

of submodules of N such that $N_p/N_{p-1} = \text{Soc}_{s_{i_p}}(N/N_{p-1})$. Define $\text{Soc}_z(N) = N_r$. For every $j \in J$, let

$$V_j = \text{Soc}_{w_{(j)}^{-1}}(Q_{i_j}) \quad \text{and} \quad U_j = \mathcal{E}_{v_{(j)}^{-1}}^\dagger V_j. \quad (3.5.1)$$

Example 3.5.5 gives a detailed construction of a module U_j .

The following theorem describes the cluster algebra structure in the coordinate ring of $\mathcal{R}_{v,w}$ and its additive categorification provided by $\mathcal{C}_{v,w}$.

Theorem 3.5.4. [30, Theorem 4.5 and Proposition 5.1] *Each pair (v, \mathbf{w}) as in Definition 3.5.3 gives a cluster-tilting module $U_{v, \mathbf{w}} := \bigoplus_{j \in J} U_j$ in $\mathcal{C}_{v,w}$, that corresponds via the cluster character φ to a seed in $\mathbb{C}[\mathcal{R}_{v,w}]$ as follows.*

- (a) *The cluster variables in $\mathbb{C}[\mathcal{R}_{v,w}]$ are the irreducible factors of $\varphi_{U_j} = \Delta_{v_{(j)}^{-1}([i_j]), w_{(j)}^{-1}([i_j])}$ for $j \in J$; they correspond to the indecomposable summands of U_j .*
- (b) *The frozen variables are the irreducible factors of $\prod_{i \in I} \Delta_{v^{-1}([i]), w^{-1}([i])}$; they correspond to the indecomposable summands of $\bigoplus_{i \in I} \mathcal{E}_{v^{-1}}^\dagger \mathcal{E}_{w^{-1}w_0}(Q_i)$ (which are the projective-injective objects).*

$$\begin{aligned}
 U_{11} &= \begin{smallmatrix} 6 \\ 5 \\ 4 \\ 3 \\ 2 \\ 1 \end{smallmatrix} & U_{12} &= \begin{smallmatrix} 6 \\ 5 \\ 4 \\ 3 \\ 2 \end{smallmatrix} & U_{13} &= \begin{smallmatrix} 6 \\ 5 \\ 4 \end{smallmatrix} & U_{15} &= \begin{smallmatrix} 5 \\ 4 \\ 3 \\ 2 \\ 1 \end{smallmatrix} \\
 U_{16} &= \begin{smallmatrix} 5 \\ 4 \\ 3 \\ 2 \end{smallmatrix} & U_{17} &= \begin{smallmatrix} 3 \\ 2 \\ 1 \end{smallmatrix} & U_{18} &= \begin{smallmatrix} 3 \\ 2 \\ 1 \end{smallmatrix} & U_{19} &= \begin{smallmatrix} 2 \\ 1 \end{smallmatrix} & U_{20} &= \begin{smallmatrix} 3 \\ 2 \\ 1 \end{smallmatrix}
 \end{aligned}$$

The projective-injective objects of $\mathcal{C}_{v,w}$ are precisely $U_{13}, U_{15}, U_{16}, U_{18}, U_{19}, U_{20}$. The endomorphism quiver $\Gamma_{U_{v,w}}$ is given below.

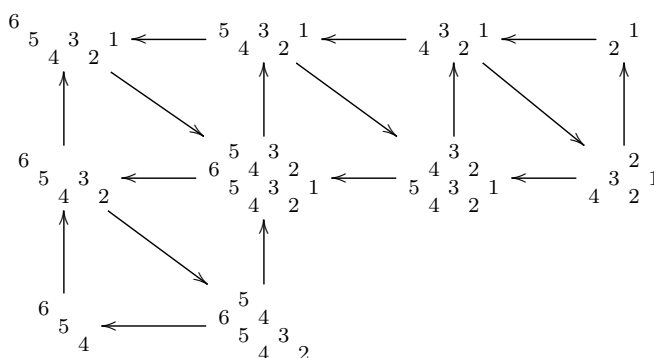

In general, it is difficult to construct the endomorphism quiver $\Gamma_{U_{v,w}}$, because it is difficult to determine whether a given morphism is irreducible in $\text{add } U_{v,w}$. For example, there is a nonzero morphism $f : U_{15} \rightarrow U_{11}$ with image $\begin{smallmatrix} 5 \\ 4 \\ 3 \\ 2 \end{smallmatrix}$ but it factors through U_{12} . Thus, f does not induce an arrow in $\Gamma_{U_{v,w}}$.

Our goal is to find an explicit description of the seed associated to a pair (v, \mathbf{w}) , where $v \in W_{\max}^K$, $w = xv$ is a length-additive factorization, and $\mathbf{w} = \mathbf{xv}$ is a standard expression for w . In Section 3.5 we will analyze the cluster variables coming from Theorem 3.5.4 (interpreting generalized minors as Plücker coordinates), and in Section 3.5 and Section 3.5 we will analyze the modules U_j and the morphisms between them, so as to obtain the quiver. The modules U_j were previously defined constructively, so we need to develop a more explicit construction, which then enables us to understand the morphisms. In the case $v = w_K$, the modules have a particularly nice structure, which allows us to explicitly compute the irreducible morphisms in $\text{add } U_{w_K, \mathbf{w}}$. Next, we use a result of [2] we show that there is a bijection between morphisms $U_i \rightarrow U_j$ in $\text{add } U_{w_k, \mathbf{w}}$ and morphisms $U'_i \rightarrow U'_j$ in $\text{add } U_{w_k v', \mathbf{w} v'}$. Then we conclude that the quiver for the pair (v, \mathbf{w}) coming from this representation theoretic construction agrees with the quiver coming from a plabic graph.

Projecting the categorical cluster variables to Grassmannians

When $v \leq w$ and $v \in W_{\max}^K$, the Richardson variety $\mathcal{R}_{v,w}$ in the complete flag variety projects isomorphically to a positroid variety $\pi_k(\mathcal{R}_{v,w})$ in the Grassmannian $\text{Gr}(k, n)$. (Concretely, elements of this positroid variety are given by the span of rows $v^{-1}\{1, \dots, k\} = v^{-1}[k]$ in

a matrix representative g for $Bg \in \mathcal{R}_{v,w}$). When additionally there is a length-additive factorization $\mathbf{w} = \mathbf{xv}$, the positroid variety is a skew Schubert variety, and Theorem 3.5.4 produces a cluster algebra which is equal to the coordinate ring $\mathbb{C}[\mathcal{R}_{v,w}]$. In this section we will determine how to interpret the cluster variables in $\mathbb{C}[\mathcal{R}_{v,w}]$ as functions on the Grassmannian.

Recall that each generalized minor $\Delta_{v^{-1}[\ell],J}$ from Theorem 3.5.4 is a minor of a unipotent upper triangular matrix. We would like to restrict that matrix to rows $v^{-1}[k]$ and then identify the minor with a Plücker coordinate of the resulting $k \times n$ matrix. To show that this is well-defined, we first need the following facts.

Lemma 3.5.6. *Let $\Delta_{I,J}$ be a minor of an $n \times n$ matrix. Then for every $A \subseteq [n]$ such that $A \subseteq I \cap J$ and every $B \subseteq [n]$ such that $I \cap B = J \cap B = \emptyset$, $\Delta_{I,J}$ agrees with $\Delta_{I \setminus A, J \setminus A}$ and $\Delta_{I \cup B, J \cup B}$ on the set of unipotent upper triangular matrices.*

Remark 3.5.7. Let $J \subseteq [n]$ with $|J| = \ell$. If we project an $n \times n$ unipotent upper triangular matrix g to the Grassmannian element represented by the span of rows $v^{-1}[k]$ of g , it follows from Lemma 3.5.6 that the generalized minor $\Delta_{v^{-1}[\ell],J}$ of g equals the following Plücker coordinate of $\text{Gr}(k, n)$:

1. If $\ell < k$ and $|J \cup v^{-1}([k] \setminus [\ell])| = k$, then $\Delta_{v^{-1}[\ell],J} = \Delta_{J \cup v^{-1}([k] \setminus [\ell])}$.
2. If $\ell = k$ then $\Delta_{v^{-1}[\ell],J} = \Delta_J$.
3. If $\ell > k$ and $|J \setminus v^{-1}([\ell] \setminus [k])| = k$, then $\Delta_{v^{-1}[\ell],J} = \Delta_{J \setminus v^{-1}([\ell] \setminus [k])}$.

For example, continuing Example 3.5.5 with $v = w_K s_3$ and w given by

$$\mathbf{w} = s_5 s_6 s_4 s_5 s_2 s_3 s_4 s_1 s_2 s_3 s_1 s_2 s_1 s_4 s_5 s_4 s_6 s_5 s_4 s_3,$$

we obtain generalized minors which map to the following Plücker coordinates:

1. $\Delta_{v^{-1}[3], v^{-1}s_3[3]} = \Delta_{124,247} = \Delta_{247}$.
2. $\Delta_{v^{-1}[2], v^{-1}s_3 s_2[2]} = \Delta_{24,47} = \Delta_{147}$.
3. $\Delta_{v^{-1}[1], v^{-1}s_3 s_2 s_1[1]} = \Delta_{4,7} = \Delta_{127}$.
4. $\Delta_{v^{-1}[4], v^{-1}s_3 s_2 s_1 s_4[4]} = \Delta_{1247,2476} = \Delta_{246}$.
5. $\Delta_{v^{-1}[3], v^{-1}s_3 s_2 s_1 s_4 s_3[3]} = \Delta_{124,467} = \Delta_{467}$.
6. $\Delta_{v^{-1}[2], v^{-1}s_3 s_2 s_1 s_4 s_3 s_2[2]} = \Delta_{24,67} = \Delta_{167}$.
7. $\Delta_{v^{-1}[5], v^{-1}s_3 s_2 s_1 s_4 s_3 s_2 s_5[5]} = \Delta_{12467,24567} = \Delta_{245}$.
8. $\Delta_{v^{-1}[4], v^{-1}s_3 s_2 s_1 s_4 s_3 s_2 s_5 s_4[4]} = \Delta_{1247,4567} = \Delta_{456}$.
9. $\Delta_{v^{-1}[6], v^{-1}s_3 s_2 s_1 s_4 s_3 s_2 s_5 s_4 s_6[6]} = \Delta_{124567,234567} = \Delta_{234}$.

10. $\Delta_{v^{-1}[5], v^{-1}s_3s_2s_1s_4s_3s_2s_5s_4s_6s_5}[5] = \Delta_{12467,34567} = \Delta_{345}$.

In light of Remark 3.5.7, we can project the generalized minors $\Delta_{v^{-1}[\ell], J}$ of Theorem 3.5.4 to Plücker coordinates so long as $|J \cup v^{-1}([k] \setminus [\ell])| = k$ (or $|J \setminus v^{-1}([\ell] \setminus [k])| = k$). Applying v^{-1} to the following lemma shows that this is the case. It also shows that Leclerc’s cluster variables in the seed corresponding to (v, \mathbf{w}) project exactly to those in the rectangles seed defined in Section 3.3.

Lemma 3.5.8. *Choose a Young diagram contained in a $k \times (n - k)$ rectangle, and label its boxes by simple reflections as in the right of Figure 3.6. Choose a reading order for the boxes as in the left of Figure 3.6. Choose any box b and let s_ℓ be its label. Let w_b be the word obtained by reading boxes in order up through b and recording the corresponding simple reflections. For example if b is the box indicated by the bold s_6 in the right of Figure 3.6, then $w_b = (s_5s_4s_3s_2)(s_6s_5s_4)(s_7s_6)$.*

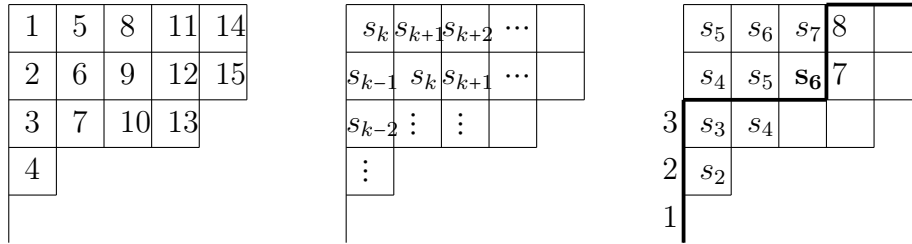

Figure 3.6:

Also let $J(b) := V^\vee(\text{Rect}(b))$ (see Definition 3.3.1). In the right of Figure 3.6, $J(b) = \{1, 2, 3, 7, 8\}$.

Then for any b and ℓ as above, let $J = w_b[\ell]$. We have that:

1. If $\ell < k$, then $J(b) = J \cup ([k] \setminus [\ell]) = J \cup \{\ell + 1, \ell + 2, \dots, k\}$.
2. If $\ell = k$, then $J(b) = J$.
3. If $\ell > k$, then $J(b) = J \setminus ([\ell] \setminus [k]) = J \setminus \{k + 1, k + 2, \dots, \ell\}$.

Proof. The proofs of the three cases are quite analogous, so we will just prove the first one, where $\ell < k$.

Let box b be in row r and column c , as in Figure 3.7, so that its label is $s_\ell = s_{k-r+c}$. We have that $r > c$.

Then $J(b) = \{1, 2, \dots, k-r\} \cup \{k-r+c+1, k-r+c+2, \dots, k+c\}$, and $J(b) \setminus \{\ell+1, \ell+2, \dots, k\} = J(b) \setminus \{k-r+c+1, k-r+c+2, \dots, k\} = \{1, 2, \dots, k-r\} \cup \{k+1, k+2, \dots, k+c\}$. We need to show that

$$w_b\{1, 2, \dots, k-r+c\} = J(b) \setminus \{k-r+c+1, k-r+c+2, \dots, k\} = \{1, 2, \dots, k-r\} \cup \{k+1, k+2, \dots, k+c\}.$$

We also see that

- for $i_1 < j < i_2$, $w_b(j) = j - 1$
- for $i_2 < j < i_3$, $w_b(j) = j - 2$
- \vdots
- for $i_{c-1} < j < i_c$, $w_b(j) = j - (c - 1)$.

So for $i_{s-1} < j < i_s$, we have that $w_b(j) = j - (s - 1) < i_s - (s - 1) \leq k - r + s - (s - 1) = k - r + 1$, and so $w_b(j) \leq k - r$. This shows that for each $j \in \{1, 2, \dots, k - r + c\}$, $w_b(j) \in \{1, 2, \dots, k - r\} \cup \{k + 1, k + 2, \dots, k + c\}$, and so $w_b[k - r + c] = \{1, 2, \dots, k - r\} \cup \{k + 1, k + 2, \dots, k + c\}$. This completes the proof of the lemma. \square

Corollary 3.5.9. *Consider a skew Schubert variety $\pi_k(\mathcal{R}_{v,w}) \subset \text{Gr}(k, n)$, where $v \leq w$, $v \in W_{\max}^K$, and with $w = xv$ length-additive. Consider the seed for $\mathcal{R}_{v,w}$ given by Theorem 3.5.4 which is associated to a standard (columnar) reduced expression $\mathbf{w} = \mathbf{xv}$. When we project the cluster variables to $\pi_k(\mathcal{R}_{v,w})$, we obtain precisely the set of Plücker coordinates from the rectangles seed (Definition 3.3.1). In other words, they are indexed by boxes b in $\lambda^\nearrow(x([k]))$, and are equal to the Plücker coordinates $\Delta_{v^{-1}(J(b))}$ in the Grassmannian.*

Proof. Let \mathbf{x} be the columnar expression for x and \mathbf{w} be a standard reduced expression for w . Let b be a box in $\lambda^\nearrow(x([k]))$, and let s_ℓ , w_b , and $J(b)$ be as defined in Lemma 3.5.8. Note that $w_b = x_{(i)}^{-1}$ for some $1 \leq i \leq \ell(x)$, so $v^{-1}w_b = w_{(j)}^{-1}$ for some j . Using Remark 3.5.7 and applying v^{-1} to Lemma 3.5.8 implies that the generalized minor $\Delta_{v^{-1}([\ell]), w_{(j)}^{-1}([\ell])}$ equals the Plücker coordinate $\Delta_{v^{-1}(J(b))}$ in the Grassmannian. Each of these Plücker coordinates is irreducible in $\mathbb{C}[\pi_k(\overline{\mathcal{R}_{v,w}})]$ (Corollary 3.5.15), so we are done. \square

It is not hard to see which Plücker coordinates are frozen in the rectangles seed.

Lemma 3.5.10. *Let x be a Grassmannian permutation of type (k, n) . Let b be a λ -frozen box of $\lambda = \lambda^\nearrow(x([k]))$, and let s_ℓ and w_b be as defined in Lemma 3.5.8. Then $w_b([\ell]) = x^{-1}([\ell])$. Thus $\Delta_{v^{-1}(J(b))}$ is frozen in the rectangles seed.*

Proof. It is clear from the filling of $\lambda^\nearrow(x([k]))$ that the boxes in columns to the right of the column of b are filled with s_i such that $i > \ell$. So $x^{-1} = w_b u$, where u is a permutation that fixes $[\ell]$ pointwise, so $w_b([\ell]) = x^{-1}([\ell])$.

Using Remark 3.5.7 and applying v^{-1} to Lemma 3.5.8 implies that $\Delta_{v^{-1}(J(b))}$ is the projection of $\Delta_{v^{-1}([\ell]), v^{-1}x^{-1}([\ell])}$ to the Grassmannian, which is frozen by Theorem 3.5.4. \square

An explicit description of the modules U_j when $w = xv$ is length-additive

Throughout this section we fix a pair (v, w) , where $w = xv$ is a length additive factorization and $v \in W_{max}^K$. Let \mathbf{w} be a standard reduced expression for w (see Definition 3.2.3). Thus, we can write $v = w_K v'$ where $v' \in W_{min}^K$, and choose reduced expressions \mathbf{x}, \mathbf{v}' for x, v' respectively as described in Lemma 3.2.1. Our goal in Section 3.5 and Section 3.5 is to prove that in this case, the quiver from Theorem 3.5.4 agrees with the quiver from the rectangles seed. Recall that the vertices of the quiver from Theorem 3.5.4 are indexed by modules U_j . In this section we will give an explicit (non-recursive) description of the composition diagrams of these modules.

Let

$$\mathbf{w} = \mathbf{xw}_K \mathbf{v}' = (s_{i_t} \dots s_{i_{r+1}})(s_{i_r} \dots s_{i_{p+1}} s_{i_p} \dots s_{i_{l+1}})(s_{i_l} \dots s_{i_1})$$

where the parenthesis separate the subexpressions $\mathbf{x}, \mathbf{w}_K, \mathbf{v}'$. In what follows, we will define a diagram $\mathcal{D}_{v,w}$ (see Figure 3.8) whose boxes are filled with simple reflections in such a way that a natural reading order of the boxes gives the reduced expression $\mathbf{w} = \mathbf{xw}_K \mathbf{v}'$. Then to each $j \in J$ (see Definition 3.5.3), we will associate a subdiagram D_j with the property that if we replace each s_i by i , D_j is precisely the composition diagram of the module U_j . More precisely, given a subdiagram of $\mathcal{D}_{v,w}$ the associated module is obtained as follows: for every s_i directly followed by s_{i+1} to the right (resp. s_{i-1} below) in the subdiagram we obtain ${}^i{}_{i+1}$ (resp. ${}^{i-1}{}^i$) in the composition factor diagram of the module (see Figure 3.11).

Definition 3.5.11. (Diagram $\mathcal{D}_{v,w}$) Extending ideas from Lemma 3.2.1, we will build a diagram $\mathcal{D}_{v,w}$ which encodes the reduced expression \mathbf{w} . We start by taking the union of diagrams $R^*(v') \cup R(w_K) \cup R(x)$, glued as in Figure 3.8, where

- $R^*(v')$ is a (rotated) Young diagram filled with simple reflections which give a reduced expression for v' , when read in the reading order indicated at the right of Figure 3.8;
- $R(w_K)$ is a pair of staircase Young diagrams filled with simple reflections which give a reduced expression for w_K ;
- $R(x)$ is a Young diagram filled with simple reflections which give a reduced expression for x .

We additionally embed $R^*(v')$ into an $(n - k) \times k$ rectangle D^* (with boxes filled with simple reflections as shown in Figure 3.8) and embed $R(x)$ into a $k \times (n - k)$ rectangle D (with boxes filled with simple reflections as shown in Figure 3.8). We let $\mathcal{D}_{v,w}$ denote the union of D, D^* and $R(w_K)$, together with the paths defining $R^*(v')$ and $R(x)$. Note that $R^*(v') \cup R(w_K) \cup R(x)$ encodes the reduced expression \mathbf{w} .

Note that $R^*(v')$ is defined by the path $L_{v'^{-1}([k])}^\swarrow$ rotated clockwise 90 degrees and then reflected across a vertical axis, while $R(x)$ is defined by the path $L_{x([k])}^\nearrow$. Finally we define the region $R(v')$ to be the subset of boxes of D below $L_{v'^{-1}([k])}^\swarrow$ (up to a rotation and and

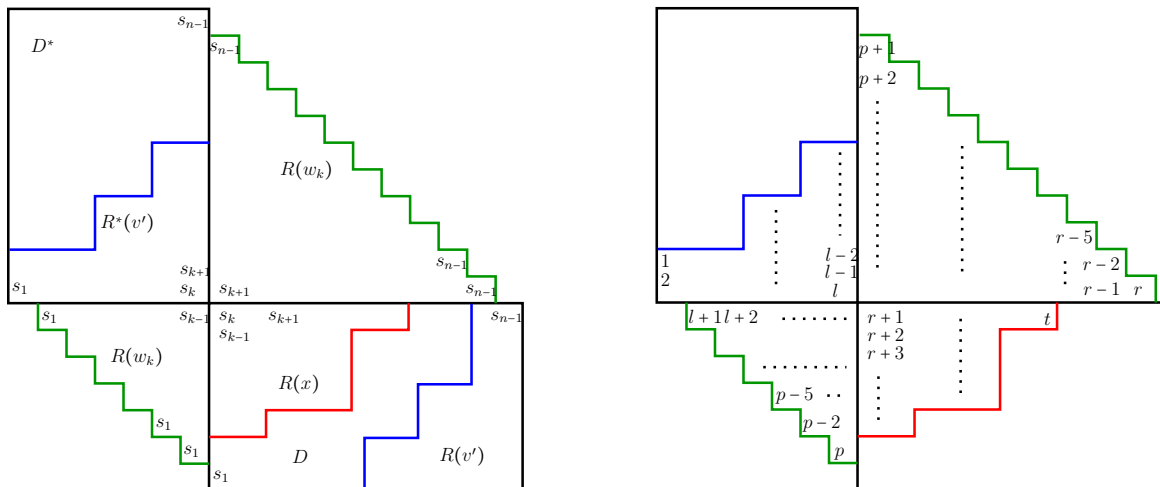

Figure 3.8: Diagram $\mathcal{D}_{v,w}$ (left) and reading order in each region (right).

reflection, it agrees with $R^*(v')$). Note that $v'^{-1}([k]) = v^{-1}([k])$, so $R(x) \cap R(v') = \emptyset$ by Lemma 3.5.12.

Let J, L be lattice paths from $(0, 0)$ to $(n-k, k)$ taking steps north and east and suppose $V^\nearrow(J) = \{j_1 < \dots < j_k\}$ and $V^\nearrow(L) = \{l_1 < \dots < l_k\}$. We say $J \leq L$ if $j_r \leq l_r$ for all r ; that is, J “lies above” L when drawn in the plane (see Figure 3.9). We leave the proof of Lemma 3.5.12 to the reader.

Lemma 3.5.12. *Let $\mathcal{A} = \{(v, w) \mid v \in W_{\max}^K, w \in W \text{ with length-additive factorization } w = xv\}$. Then the following map is a bijection:*

$$\begin{aligned} \mathcal{A} &\rightarrow \{(J, L) \mid J \leq L \text{ lattice paths from } (0, 0) \text{ to } (n-k, k)\} \\ (v, xv) &\mapsto (L_{x([k])}^\nearrow, L_{v^{-1}([k])}^\swarrow). \end{aligned}$$

In particular, if $(v, xv) \in \mathcal{A}$ then $L_{x([k])}^\nearrow \leq L_{v^{-1}([k])}^\swarrow$.

Next, we associate specific regions D_j^*, D_j in $\mathcal{D}_{v,w}$ to the modules V_j, U_j .

Construction of $D_j^* \subset \mathcal{D}_{v,w}$. Given $j \in J$ there exists a corresponding box $b_j \in R(x)$ filled with the simple generator s_{i_j} .

By Definition 3.5.3, $V_j = \text{Soc}_{w_{(j)}^{-1}}(Q_{i_j})$; we will construct a subdiagram D_j^* of $\mathcal{D}_{v,w}$ that yields a composition diagram for the module V_j . See Figure 3.10.

We can write $w_{(j)} = x_{(j)}w_K v'$, where $\mathbf{x}_{(j)}$ comes from entries in $R(x)$ to the left and above b_j . In the definition of V_j , we begin with the injective module Q_{i_j} . Note that Q_{i_j} corresponds to the maximal rectangle $R(Q_{i_j})$ in $\mathcal{D}_{v,w}$ whose lower right corner is b_j . Next,

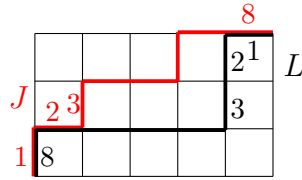

Figure 3.9: Let $k = 3$ and $n = 7$. Let $x = (1, 3, 6, 2, 4, 5, 7, 8) \in {}^K W$, $v = (8, 3, 2, 7, 6, 5, 4, 1) \in W_{\max}^K$ and $w = xv$. The upper lattice path J is $L_x^{\nearrow}([k])$, with $V^{\nearrow}(J) = x([3]) = \{1, 3, 6\}$; the lower lattice path L is $L_{v^{-1}}^{\leftarrow}([k])$, with $V^{\leftarrow}(L) = v^{-1}([3]) = \{2, 3, 8\}$. Since $w = xv$ is length-additive, the bijection of Lemma 3.5.12 sends (v, w) to (J, L) .

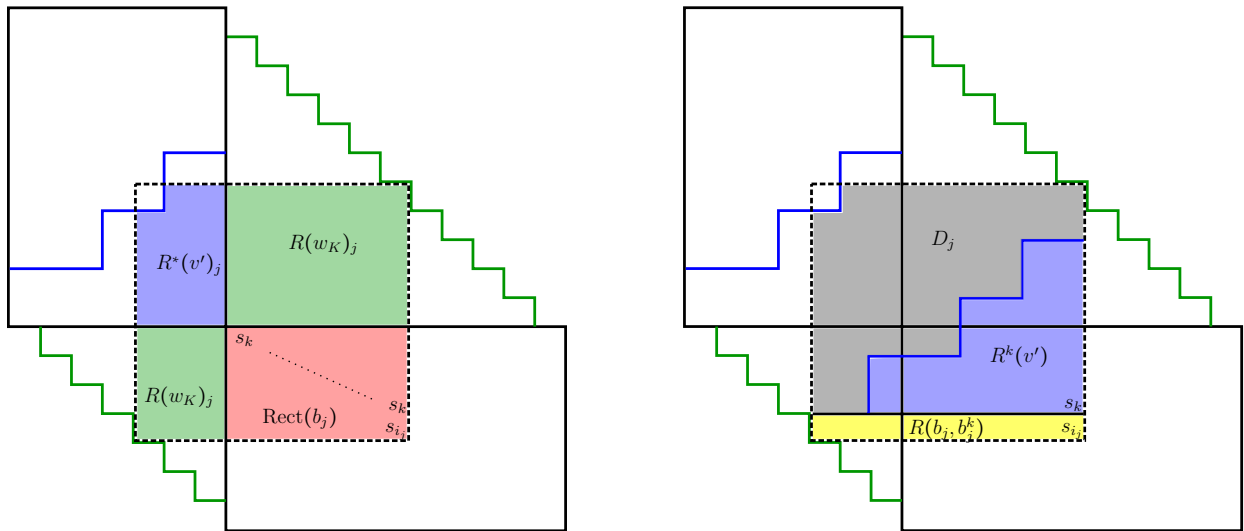

Figure 3.10: Construction of subdiagrams D_j^* (left) and D_j (right).

consider the subdiagram associated to the module $\text{Soc}_{x_{(j)}^{-1}}(Q_{i_j})$. The columnar expression for $x_{(j)}$ can be written as follows

$$x_{(j)} = s_{i_j} s_{i_j+1} s_{i_j+2} \cdots s_a s_{i_j-1} s_{i_j} s_{i_j+1} \cdots s_{a-1} \cdots s_b s_{b+1} s_{b+2} \cdots s_k$$

where s_a (resp. s_b) is the filling of the box in the first row (resp. column) of D and in the same column (resp. row) as b_j . It is compatible with the structure of Q_{i_j} depicted in Section 3.5 in the following sense.

$$\text{Soc}_{s_{i_j}}(Q_{i_j}) = i_j \quad \text{Soc}_{s_{i_j+1} s_{i_j}}(Q_{i_j}) = \begin{matrix} i_j+1 \\ i_j \end{matrix} \quad \text{Soc}_{s_a \cdots s_{i_j+2} s_{i_j+1} s_{i_j}}(Q_{i_j}) = \begin{matrix} a \\ \cdots \\ i_j+1 \\ i_j \end{matrix}$$

$$\text{Soc}_{s_{i_j-1}s_a \dots s_{i_j+2s_{i_j+1}s_{i_j}}} (Q_{i_j}) = \begin{array}{c} a \\ \dots \\ i_j+1 \\ i_j \end{array} \quad \text{Soc}_{s_{a-1} \dots s_{i_j}s_{i_j-1}s_a \dots s_{i_j+2s_{i_j+1}s_{i_j}}} (Q_{i_j}) = \begin{array}{c} a \\ a-1 \\ \dots \\ i_j+1 \\ i_j \end{array} \dots \begin{array}{c} a-2 \\ \dots \\ i_j-1 \end{array}$$

Continuing in this way, we see that the module $\text{Soc}_{x_{(j)}^{-1}}(Q_{i_j})$ is given by the rectangle $\text{Rect}(b_j) \subseteq D$, whose southeast box is b_j . Next, in the definition of V_j we need to compute $\text{Soc}_{w_K x_{(j)}^{-1}}(Q_{i_j})$. First, observe that s_k does not appear in a reduced expression for w_K , therefore the subdiagram of $\mathcal{D}_{v,w}$ associated to $\text{Soc}_{w_K x_{(j)}^{-1}}(Q_{i_j})$ has trivial intersection with D^* . Recall that the boxes in $R(w_K)$ yield a reduced expression for w_K . Thus, we see that the subdiagram for $\text{Soc}_{w_K x_{(j)}^{-1}}(Q_{i_j})$ is obtained by extending $\text{Rect}(b_j)$ to the north and west as much as possible, while avoiding boxes with entries s_k . In particular, we have

$$R(\text{Soc}_{w_K x_{(j)}^{-1}}(Q_{i_j})) = \text{Rect}(b_j) \cup R(w_K)_j$$

where $R(w_K)_j = R(w_K) \cap R(Q_{i_j})$. Finally, D_j^* is obtained from $R(\text{Soc}_{w_K x_{(j)}^{-1}}(Q_{i_j}))$ by adding as many boxes in $R^*(v')$ as possible, such that the result is still contained in $R(Q_{i_j})$. Let $R^*(v')_j = R(Q_{i_j}) \cap R^*(v')$. Then

$$D_j^* = \text{Rect}(b_j) \cup R(w_K)_j \cup R^*(v')_j. \quad (3.5.3)$$

Remark 3.5.13. The subdiagram D_j^* can also be obtained as follows. Given the box b_j , let R be the maximal rectangle contained in $\mathcal{D}_{v,w}$ with b_j as its southeast corner. Then D_j^* results from R by removing boxes of $R \cap D^*$ which are not in $R^*(v')$.

Construction of $D_j \subset \mathcal{D}_{v,w}$. By Definition 3.5.3, $U_j = \mathcal{E}_{v_{(j)}^{-1}}^\dagger V_j$ is obtained by removing simple modules from the socle of V_j according to the simple reflections appearing in a reduced expression for $v_{(j)}^{-1}$. Note that in this case $v_{(j)} = w_K v'$. Again since w_K does not have s_k in its reduced expression and it is the longest element of W_K , we see that $\mathcal{E}_{w_K}^\dagger V_j$ is obtained from V_j by quotienting out the largest submodule of V_j not supported at vertex k . In particular, if $i_j = k$ then $\mathcal{E}_{w_K}^\dagger V_j = V_j$. If $i_j < k$ then there exists a unique box $b_j^k \in \text{Rect}(b_j)$ with entry s_k located above b_j and in the same column as b_j . Let $R(b_j, b_j^k)$ be the maximal rectangle in D_j^* with lower right corner b_j and height $k - i_j$ (see Figure 3.10). That is, the upper right corner of $R(b_j, b_j^k)$ is the box directly below b_j^k . We see that the module associated to $R(b_j, b_j^k)$ is the largest submodule of V_j not supported at vertex k . Therefore, $R(\mathcal{E}_{w_K}^\dagger V_j) = D_j^* \setminus R(b_j, b_j^k)$. Similarly, if $i_j > k$ then there exists a unique box $b_j^k \in \text{Rect}(b_j)$ with entry s_k located to the left of b_j and in the same row as b_j . Let $R(b_j, b_j^k)$ be the maximal rectangle in D_j^* with lower right corner b_j of width $i_j - k$. That is, the lower left corner of $R(b_j, b_j^k)$ is the box directly to the right of b_j^k , and as before we obtain $R(\mathcal{E}_{w_K}^\dagger V_j) = D_j^* \setminus R(b_j, b_j^k)$.

Finally, it remains to compute $\mathcal{E}_{v_{(j)}^{-1}}^\dagger \mathcal{E}_{w_K}^\dagger V_j$. Note that the columnar expression for v' is again compatible with the structure of $\mathcal{E}_{w_K}^\dagger V_j$, see the computations below. We have

$$v' = s_k s_{k+1} \dots s_{l_1} s_{k-1} s_k \dots s_{l_2} \dots s_{k-q-1} s_{k-q} \dots s_{t_q}$$



Figure 3.11: D_{12} from Example 3.5.5.

where s_{l_i} is the filling of the upper-most box in column i of region $R^*(v') \subset \mathcal{D}_{v,w}$, if we label the columns of $R^*(v')$ by $1, 2, \dots, q$ right to left.

The socle of $\mathcal{E}_{w_K}^\dagger V_j$ is precisely S_k , and s_k is the first reflection in \mathbf{v}' . Thus, $\mathcal{E}_{s_k w_K}^\dagger V_j$ is obtained from $\mathcal{E}_{w_K}^\dagger V_j$ by removing the simple module S_k from the socle. Similarly, S_{k+1} is in the socle of $\mathcal{E}_{s_k w_K}^\dagger V_j$, and s_{k+1} is the second reflection in \mathbf{v}' , provided the first column of $R^*(v')$ has at least two boxes. Therefore, $\mathcal{E}_{s_{l_1} \dots s_{k+1} s_k w_K}^\dagger V_j$ is obtained from $\mathcal{E}_{w_K}^\dagger V_j$ by removing a portion of the left-most diagonal between labels k and l_1 from the composition diagram for $\mathcal{E}_{w_K}^\dagger V_j$.

$$\mathcal{E}_{w_K}^\dagger V_j = \begin{array}{cccccccc} & & \ddots & & \vdots & & \ddots & & \\ & & l_{1+1} & & \vdots & & l_{1+3} & & \\ & & & & l_1 & & & & \\ & & & & & & \ddots & & \\ & & & & & & k+2 & & \ddots & & \\ & & & & & & k+1 & & \ddots & & \\ & & & & & & k & & \ddots & & \\ & & & & & & k-1 & & \ddots & & \\ & & & & & & & & k-2 & & \\ & & & & & & & & & & k-q \\ & & & & & & & & & & k-q \end{array} \quad \mathcal{E}_{s_{l_1} \dots s_{k+1} s_k w_K}^\dagger V_j = \begin{array}{cccccccc} & & \ddots & & \vdots & & \ddots & & \\ & & l_{1+1} & & \vdots & & l_{1+3} & & \\ & & & & l_1 & & & & \\ & & & & & & \ddots & & \\ & & & & & & k & & \ddots & & \\ & & & & & & k-1 & & \ddots & & \\ & & & & & & & & k-2 & & \\ & & & & & & & & & & k-q \\ & & & & & & & & & & k-q \end{array}$$

Continuing in this way, we see that D_j , the subdiagram associated to U_j , results from $R(\mathcal{E}_{w_K}^\dagger V_j)$ by removing the diagram $R^k(v')$, where $R^k(v')$ is obtained from $R^*(v')$ by shifting $R^*(v')$ southeast until its bottom right corner box is b_j^k (see Figure 3.10). This completes the construction of the region

$$D_j = D_j^* \setminus (R(b_j, b_j^k) \cup R^k(v')). \tag{3.5.4}$$

Now, we use the above constructions to find a simple description of D_j as a subdiagram of D . See Figure 3.11 for an example of such a transformation.

Let b_j be a box in $\lambda^\vee(x([k]))$ (or equivalently a box in $R(x)$). This box corresponds to the module U_j and by Corollary 3.5.9 the associated Plücker coordinate is Δ_{P_j} where $P_j = v^{-1}(J(b_j))$ (see Definition 3.3.1).

Let $r(D)$ be the $k \times (n - k)$ diagram obtained by rotating D clockwise 180 degrees. Define $R(P_j)$ to be the region in $r(D)$ bounded by the lattice paths $L_{P_j}^\vee$ and $L_{v^{-1}([k])}^\vee$ (see Figure 3.12).

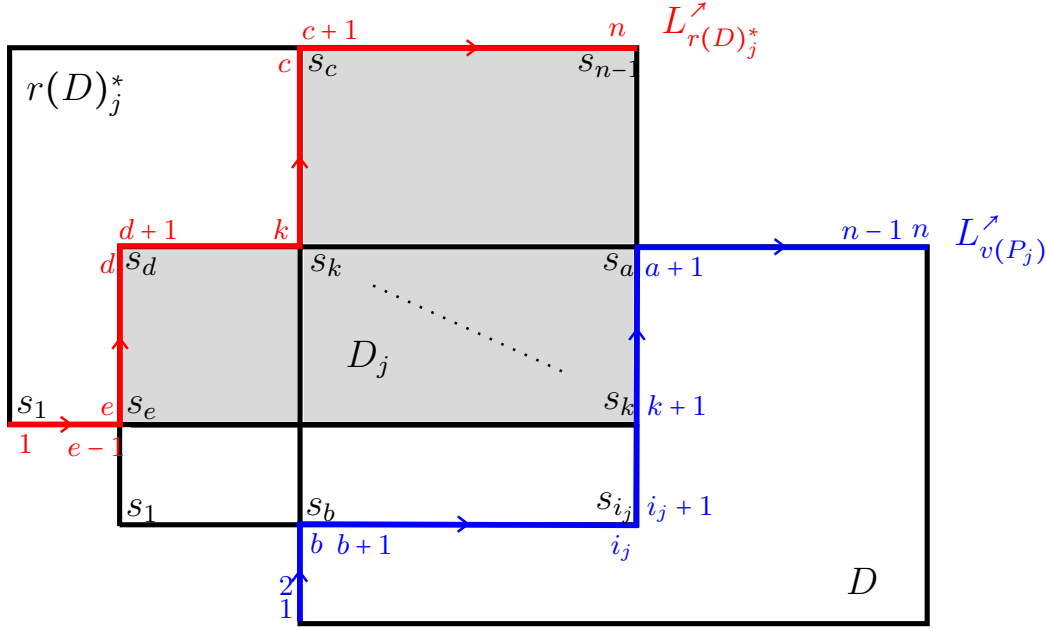
 Figure 3.13: Base case $v' = e$

We claim that $P_j = P$, where Δ_{P_j} denotes the Plücker coordinate associated to the box b_j .

By Lemma 3.5.8, the lattice path $L_{v(P_j)}^*$ in D cuts out a rectangle in the northwest corner of D . In our case, this statement implies that

$$v(P_j) = w_K(P_j) = \{1, 2, \dots, b-1\} \cup \{i_j+1, i_j+2, \dots, a+1\}.$$

Applying w_K to this set where

$$w_K = \begin{pmatrix} 1 & 2 & \dots & i & \dots & k & k+1 & \dots & j & \dots & n-1 & n \\ k & k-1 & \dots & k+1-i & \dots & 1 & n & \dots & n-(j+k-1) & \dots & k+2 & k+1 \end{pmatrix}$$

we see that

$$P_j = \{k, k-1, \dots, k-b+2\} \cup \{k-i_j, k-i_j-1, \dots, 1\} \cup \{n, n-1, \dots, n-a+k\}.$$

It follows from Figure 3.13 that $e = k - i_j + 1$, $d = k - b + 1$, $c = n - a + k - 1$, which implies that $P_j = P$. This completes the proof that the top contour of D_j given by $L_{r(D)_j}^*$ has horizontal steps P_j in the case $v' = e$.

Now, consider the pair (v, \mathbf{w}) and some (vs_t, \mathbf{ws}_t) such that the length of each element increases by one. By induction hypothesis assume that the horizontal steps of top contour of D_j , coming from the pair (v, \mathbf{w}) , are given by P_j .

Let U'_j be the module associated to the box b_j and coming from the pair (vs_t, ws_t) . Let P'_j denote the corresponding element of $\binom{[n]}{k}$ for the pair (vs_t, ws_t) . Observe that by changing

This completes the proof of the induction step for the top contour of D_j .

Thus, we showed that the bottom and top contour of $D_j \subset r(D)_j^*$ has horizontal steps given by $v^{-1}[k]$ and P_j respectively. Moreover, after rotating $r(D)_j^*$ clockwise 90 degrees and reflecting it across a vertical axis, we obtain the desired region $R(P_j)$, that yields the composition factor diagram for U_j , as a subset of $r(D)$. For an example of this transformation see Figure 3.11. Note that in this way a northeast lattice path L^\nearrow in $r(D)_j^*$ becomes a southwest path L^\swarrow in $r(D)$. Also, horizontal steps of L^\nearrow become vertical steps of L^\swarrow . This completes the proof of the theorem. \square

Corollary 3.5.15. *Let $w = xv$ where $v \in W_{max}^K$ and $\ell(w) = \ell(x) + \ell(v)$. Given a pair (v, \mathbf{w}) , where \mathbf{w} is a standard reduced expression for w , for each $j \in J$ the module U_j is indecomposable and the Plücker coordinate Δ_{P_j} is irreducible.*

Proof. By construction of the diagram D_j , its bottom and top contour do not intersect, except on the boundary of $r(D)_j^*$, and moreover $R(P_j) \subset R(Q_k)$. In particular, the composition diagram for the module U_j is connected. This shows that U_j is indeed indecomposable, and then Theorem 3.5.4 implies that the associated Plücker coordinate Δ_{P_j} is irreducible. \square

An explicit description of the endomorphism quiver $\Gamma_{U_{v,\mathbf{w}}}$

In order to understand the endomorphism quiver, we need to analyze morphisms between indecomposable summands of $U_{v,\mathbf{w}}$.

Recall that for a box $b_i \in R(x)$, U_i denotes the associated summand of $U_{v,\mathbf{w}}$. Also, recall that $\text{Rect}(b_i)$ is the maximal rectangle in D whose southeast corner is b_i .

Theorem 3.5.16. *Consider (v, w) where $v \in W_{max}^K$ and $w = xv$ is length-additive. Let $\mathbf{w} = \mathbf{xv} = \mathbf{xw}_k\mathbf{v}'$ be a standard reduced expression for w . For any pair of modules $U_i, U_j \in \text{ind } U_{v,\mathbf{w}}$ there exists an irreducible morphism $U_i \rightarrow U_j$ in $\text{add } U_{v,\mathbf{w}}$ if and only if one of the following conditions holds:*

- (i) $\text{Rect}(b_j)$ is obtained from $\text{Rect}(b_i)$ by removing a row
- (ii) $\text{Rect}(b_j)$ is obtained from $\text{Rect}(b_i)$ by removing a column
- (iii) $\text{Rect}(b_j)$ is obtained from $\text{Rect}(b_i)$ by adding a hook shape.

Moreover, there exists at most one irreducible morphism between U_i and U_j .

Before proving Theorem 3.5.16, we make the following key observation.

Remark 3.5.17. Let $f : U_i \rightarrow U_j$ be a homomorphism, and suppose that N is an indecomposable direct summand of $\text{im } f$. Then because $\text{im } f$ is a submodule of U_j and is (isomorphic to) a quotient of U_i , the composition diagram for N embeds into those for U_i, U_j . Moreover, N is closed under predecessors in U_i : for all vertices x and $y \in I$ in the composition diagrams for N and U_i , respectively, such that y lies immediately above x in U_i (that is $\begin{smallmatrix} y \\ x \end{smallmatrix}$ or $\begin{smallmatrix} & y \\ x & \end{smallmatrix}$) we

have that y is also in the composition diagram for N . Similarly, N is *closed under successors* in U_j : for all vertices $x, y \in I$ in the diagrams for N, U_j such that y lies immediately below x in U_j (that is $\begin{smallmatrix} x & \\ & y \end{smallmatrix}$ or $\begin{smallmatrix} & x \\ y & \end{smallmatrix}$), we have that y is also in the diagram for N .

Conversely, for any N that is closed under predecessors in U_i and closed under successors in U_j we get a morphism $f : U_i \rightarrow U_j$ with image N .

We will prove Theorem 3.5.16 in two steps. First we treat the case $v' = e$, i.e. $v = w_K$.

Proposition 3.5.18. *Theorem 3.5.16 is true when $v = w_K$, i.e. $v' = e$.*

Proof. By the proof of Theorem 3.5.14 all indecomposable summands of $U = U_{v,w}$ are of the form given in Figure 3.15. Moreover, we must have $S_k = \text{Soc } U_i = \text{Soc } U_j$ and either $c_i + r_i = k$ or $a_i + r_i = n - k$ for any $U_i \in \text{ind } U$. Thus, we can rephrase the statement of the theorem in terms of these new parameters a_i, c_i, r_i that define a given summand of U . Here both (ia) and (ib) correspond to case (i) of the theorem, depending if b_i is above or below the main diagonal. Similar correspondences hold for the remaining cases.

$$(ia) \quad r_i = r_j + 1, \quad a_i = a_j, \quad \text{and} \quad c_i + r_i = c_j + r_j = k$$

$$(ib) \quad r_i = r_j, \quad c_i = c_j - 1, \quad \text{and} \quad a_i + r_i = a_j + r_j = n - k$$

$$(iia) \quad r_i = r_j, \quad a_i = a_j - 1, \quad \text{and} \quad c_i + r_i = c_j + r_j = k$$

$$(iib) \quad r_i = r_j + 1, \quad c_i = c_j, \quad \text{and} \quad a_i + r_i = a_j + r_j = n - k$$

$$(iiia) \quad r_i = r_j - 1, \quad a_i = a_j + 1, \quad \text{and} \quad c_i + r_i = c_j + r_j = k$$

$$(iiib) \quad r_i = r_j - 1, \quad c_i = c_j + 1, \quad \text{and} \quad a_i + r_i = a_j + r_j = n - k.$$

By the construction of the region $D_j \subset \mathcal{D}_{v,w}$ (see Figure 3.13), given $U_i \in \text{add } U$ defined by a_i, r_i, c_i a module U_z defined by a_z, r_z, c_z is also in $\text{add } U$ if $r_z \leq a_z$ and either $a_z = a_i, c_z \geq b_i$ or $c_z = c_i, a_z \geq a_i$. Indeed, every module in $\text{add } U$ corresponds to a unique box in $R(x)$. Given a box $b_i \in R(x)$ associated to the module U_i , all the boxes $b_z \in D$ above and to the left of b_i are also in $R(x)$. The module U_z with the above properties is precisely the one coming from such a box $b_z \in R(x)$. Thus, $U_z \in \text{add } U$ as claimed.

Below we consider an arbitrary morphism $f : U_i \rightarrow U_j$, and using the particular structure of the modules we show that it factors through another summand U' of U . Moreover, we obtain two maps $U_i \rightarrow U'$ and $U' \rightarrow U_j$ whose composition is f together with additional conditions on the structure of U' . Since we are interested in the case when f is irreducible, we can reduce f to the case $U_i \rightarrow U' = U_j$ or $U' = U_i \rightarrow U_j$. We then continue in the same way replacing f by one of the two morphisms. At every step we obtain more information about the particular structure of U_i and U_j until we recover the case listed in the theorem.

Let $f : U_i \rightarrow U_j$ be a nonzero nonidentity morphism in $\text{mod } \Lambda$. Since U_j has a one-dimensional socle it follows that $\text{im } f$, which is a submodule of U_j , is indecomposable. Let

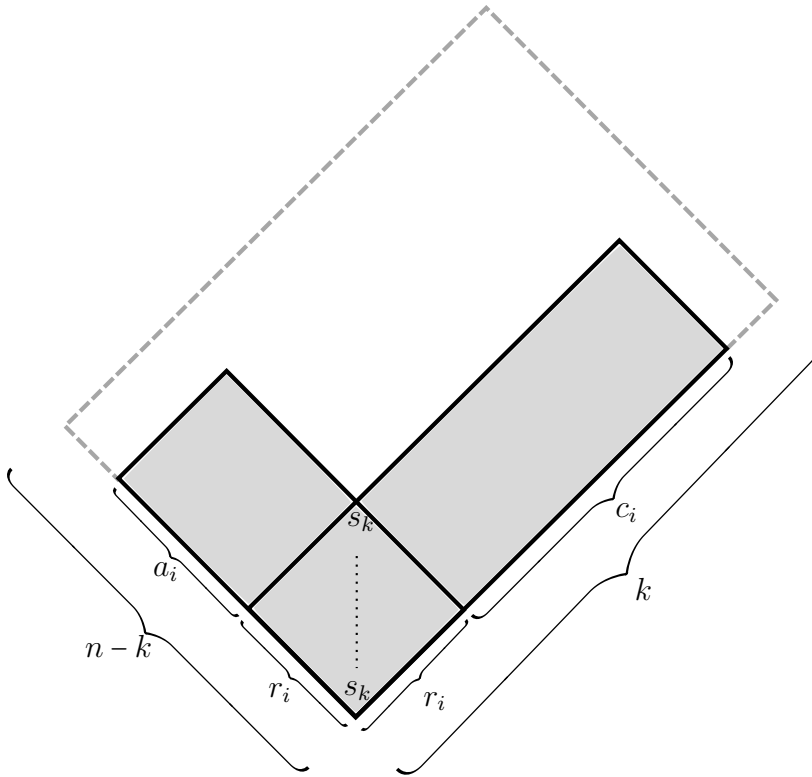

Figure 3.15: Module U_i

$N = \text{im } f$. By Remark 3.5.17 it is closed under predecessors in U_i and closed under successors in U_j . Moreover, the socle of N is also S_k , and we obtain the configuration depicted in Figure 3.16. Here, $r_z \leq r_i, r_j, r_z + c'_z \leq r_j + c_j$, and $r_z + a_z \leq r_j + a_j$. Conversely, for every such N as in the figure we obtain a nonzero morphism $U_i \rightarrow U_j$.

First, we consider the case $r_i + c_i = k$ and $r_j + c_j = k$. Note that N is not necessarily in $\text{add } U$. Thus, we construct a module $U_z \in \text{ind } \Lambda$ of the same structure as U_i, U_j defined by $a_z = a_i, r_z$, and c_z such that $c_z + r_z = k$. Since $r_z \leq r_i$ and $c_z \geq c_i$ it follows that $U_z \in \text{ind } U$. We also obtain maps $g : U_i \rightarrow U_z$ and $h : U_z \rightarrow U_j$ such that $f = hg$. This implies that f is reducible in $\text{add } U$ unless $g = 1$ or $h = 1$.

As we are interested in irreducible morphisms f , suppose first that $h = 1$. Thus, $U_z = U_j$ and $f = g$. If $r_z = r_i$, then $U_i = U_z$ and $g = f = 1$ contrary to our original assumption that f is not the identity morphism. Now, if $r_z < r_i$ consider a module U_t defined by $a_t = a_i, r_t = r_z + 1$ and c_t such that $c_t + r_t = k$. In particular, $c_t = c_z - 1$. Since $r_t \leq r_i$ and $c_t > c_i$ it follows that $U_t \in \text{add } U$. In this case, we note that f factors through U_t . That is, there exist maps ρ, π as

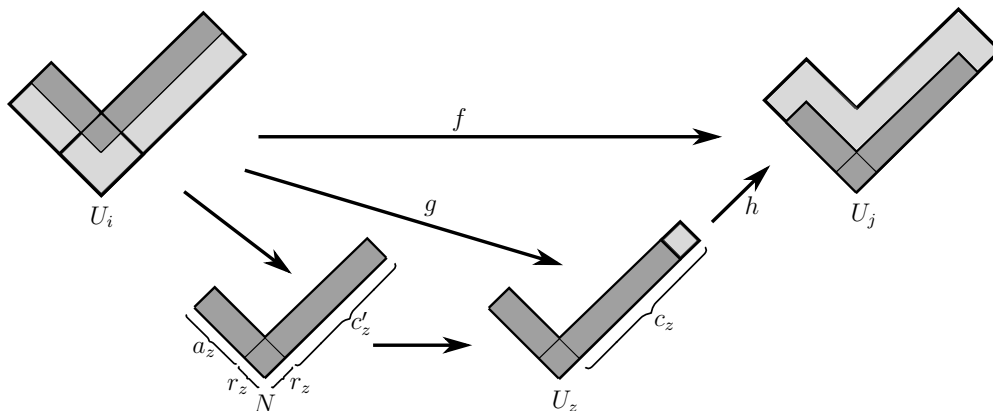

Figure 3.16: Morphism $f : U_i \rightarrow U_j$ with image N

below

$$\begin{array}{ccc}
 U_i & \xrightarrow{f=g} & U_z \\
 & \searrow \rho & \nearrow \pi \\
 & U_t &
 \end{array}$$

such that $f = \pi\rho$. Note that by definition $\pi \neq 1$ as $c_t \neq c_z$. Since we are interested in irreducible morphisms f , we consider the case $\rho = 1$ and $f = \pi$. If $f = \pi$ then we have $U_i = U_t$ and $U_j = U_z$. By construction, $a_i = a_j$, $r_i = r_j + 1$ and $c_i + r_i = c_j + r_j = k$, which agrees with case (ia). Conversely, by the structure of U_i and U_j it is easy to see that such f is indeed irreducible in $\text{add } U$.

Now, consider the case $g = 1$. Thus, $h = f$ and $U_z = U_i = X$. Let U_q be the module defined by $a_q = a_z + 1$, $r_q = r_z$, $c_q = c_z$, provided that $a_z + r_z < n - k$. Observe that $U_q \in \text{add } U$ because $r_q = r_z$ and $c_q > a_z$. If $a_q + r_q \leq a_j + r_j$, we see that f factors through U_q . In particular, there exist morphisms σ, δ as below

$$\begin{array}{ccc}
 U_z & \xrightarrow{f=h} & U_j \\
 & \searrow \sigma & \nearrow \delta \\
 & U_q &
 \end{array}$$

where $f = \delta\sigma$. Since we are looking for irreducible maps we take $\delta = 1$. Note that $\sigma \neq 1$ as $a_z < a_q$. In the case $\delta = 1$ we have $f = \sigma$ is injective, and $U_z = U_i$, $U_q = U_j$. Therefore, $r_i = r_j$, $a_i = a_j - 1$, and $r_i + c_i = r_j + c_j = k$, which is precisely the conditions of case (iia). Also, because f is injective, we can see by the particular structure of U_i and U_q that it is actually irreducible in $\text{add } U$.

It remains to consider the the case $f = h$ and $a_z + r_z = a_j + r_j$. First, we observe that $r_z \neq r_j$, as otherwise $U_i = U_z = U_j$ and f is the identity map. Thus, let U_p be the module defined by $r_p = r_z + 1$, $a_p = a_z - 1$, $c_p = c_z - 1$, provided a_z, c_z are both nonzero. In this case,

$U_p \in \text{add } U$ because $r_p \leq r_j$ and $a_p \geq a_j$. Thus, we see that $f = h$ factors through U_p

$$\begin{array}{ccc} U_z & \xrightarrow{f=h} & U_j \\ & \searrow \epsilon & \nearrow \theta \\ & & U_p \end{array}$$

where $f = \theta\epsilon$. Note that $\epsilon \neq 1$ by construction, therefore we consider the case $\theta = 1$. Thus, $f = \epsilon$ and $U_z = U_i, U_j = U_p$, where $r_i = r_j - 1$, $a_i = a_j + 1$, and $c_i + r_i = c_j + r_j = k$. In particular, this agrees with case (iiia) of the lemma. Again, since f is injective it is easy to see that it is irreducible in $\text{add } U$.

Finally, suppose that $f = h$ and $a_z + r_z = a_j + r_j$ as above, but $a_z = 0$ or $c_z = 0$. If $a_z = 0$ then $r_z = a_j + r_j$. We also know that U_z maps injectively into U_j via f . Therefore, $r_z \leq r_j$ which implies that $a_j = 0$. We obtain $U_z = U_i = U_j$ and f is the identity morphism. This is a contradiction. On the other hand, if $c_z = 0$ then $r_z = k$. Since $r_z \leq r_j \leq k$, we obtain $r_j = k$. Also, $a_j + r_j \leq k$ implies that $a_j = 0$ and we deduce a contradiction as above.

This completes the proof when $c_i + r_i = c_j + r_j = k$. A similar argument applies in the case $a_i + r_i = a_j + r_j = n - k$. Therefore, it remains to consider the situation when $r_i + c_i = k$ and $a_j + r_j = n - k$ while $r_i + a_i < n - k$ and $c_j + r_j < k$ and vice versa. In particular, we want to show that every morphism in this case is reducible. Suppose that $f : U_i \rightarrow U_j$ where $r_i + c_i = k$ and $r_j + c_j = n - k$ while $r_i + a_i < n - k$ and $c_j + r_j < k$. The other case follows similarly. Now, obtain a module U_u defined by $r_u = r_i, a_u + r_u = n - k, c_u + r_u = k$. Note that U_u is different from both U_i and U_j . Moreover, $U_u \in \text{add } U$ because $r_u = r_i$ and $a_u > a_i$. We obtain that f factors through U_u . In particular, f is reducible in $\text{add } U$ and the resulting maps $U_i \rightarrow U_u$ and $U_u \rightarrow U_j$ are between types of modules that we considered earlier. This shows that such f does not yield any new irreducible morphisms, as desired. \square

In the second step in the proof of Theorem 3.5.16, we relate morphisms between summands of $U_{v,w}$, and morphisms between summands of U_{w_K, xw_K} where $w = xv$ and $v \in W_{max}^K$.

Lemma 3.5.19. *Let $w = xv$, where $v \in W_{max}^K$ and $\ell(w) = \ell(x) + \ell(v)$. Denote the cluster-tilting modules coming from a standard reduced expressions for the pairs (w_K, xw_K) and (v, w) by U, U' respectively. Let $U_i, U_j \in \text{ind } U$ and let $U'_i, U'_j \in \text{ind } U'$ be the corresponding summands of U' . Then, there exists a bijection between irreducible morphisms $U_i \rightarrow U_j$ in $\text{add } U$ and irreducible morphisms $U'_i \rightarrow U'_j$ in $\text{add } U'$.*

Proof. By [2, Proposition 5.16] there are equivalences of categories $\mathcal{C}_x \xrightarrow{\sim} \mathcal{C}_{v,w}$ and $\mathcal{C}_x \xrightarrow{\sim} \mathcal{C}_{w_K, xw_K}$. In particular, the categories $\mathcal{C}_{v,w}$ and \mathcal{C}_{w_K, xw_K} are also equivalent. By [30, Remark 5.2] this equivalence identifies the two cluster-tilting modules U and U' . In particular, this implies that there is a bijection between irreducible morphisms $U_i \rightarrow U_j$ in $\text{add } U$ and irreducible morphisms $U'_i \rightarrow U'_j$ in $\text{add } U'$. \square

Together Proposition 3.5.18 and Corollary 3.5.19 prove Theorem 3.5.16. Next, we present the main theorem of this section.

Theorem 3.5.20. *Let $w = xv$ be a length additive factorization and $v \in W_{\max}^K$. For a standard reduced expression \mathbf{w} of w , the labeled quiver $\Gamma_{U_{v,\mathbf{w}}}$ coincides with $Q_{v,w}$.*

Proof. By Definition 3.3.1 and Theorem 3.5.16, the quivers coincide. And by the construction of Δ_{P_j} and Lemma 3.5.8, the labels of the vertices coincide as well. \square

As a corollary, we obtain Proposition 3.3.3.

3.6 The proofs of Theorem 3.1.6 and Theorem 3.1.7

In this section we first prove Theorem 3.1.7, and then deduce Theorem 3.1.6 from it.

The proof of Theorem 3.1.7

Let $v \leq w$ be permutations where $v \in W_{\max}^K$ and $w = xv$ is a length-additive factorization. By Leclerc's result (Theorem 3.5.1 and Proposition 3.5.2), the cluster algebra $\tilde{\mathcal{R}}_{v,w}$ he constructs is equal to $\mathbb{C}[\mathcal{R}_{v,w}]$. So we need to identify his cluster algebra with the one coming from plabic graphs.

Let \mathbf{w}' be a standard reduced expression for $w' := xw_K$ and let $G_{v,w}$ be the graph obtained from the bridge graph $B_{w_K,\mathbf{w}'}$ by applying v^{-1} to the boundary vertices. We label the faces of $G_{v,w}$ using the target labeling and let $Q_{v,w}$ be the labeled dual quiver of $G_{v,w}$ with the vertex labeled $v^{-1}([k])$ removed. So far, we have shown that $Q_{v,w}$ is the rectangles seed (Proposition 3.4.11), and that $Q_{v,w}$ agrees with $\Gamma_{U_{v,\mathbf{w}'}}$ (Theorem 3.5.20).

Now, let G be a plabic graph obtained from $G_{v,w}$ by a sequence of moves (M1)-(M3). The boundary faces of G have the same labels as the boundary faces of $G_{v,w}$. Let Q be the dual quiver of G , with the vertex labeled $v^{-1}([k])$ removed. Recall that a square move at a face of a plabic graph changes the dual quiver via mutation at the corresponding vertex. So we can obtain Q from $Q_{v,w}$ by a sequence of mutations. On the other hand, this same sequence of mutations can be performed on the corresponding cluster-tilting module $U_{v,\mathbf{w}'}$ and its labeled quiver $\Gamma_{U_{v,\mathbf{w}'}}$ resulting in a new module U and its labeled quiver Γ_U . Now, labeling Q with target labels, we claim that $Q = \Gamma_U$. The two quivers are clearly equal if we ignore the labels, so we only need to show that the labelings coincide. In order to do so, we first establish that the face labels of G have the following property.

Definition 3.6.1. Let $I, J \in \binom{[n]}{k}$. We say I and J are *weakly separated* if for all $a, b \in I \setminus J$ and $c, d \in J \setminus I$ with $a < b$ and $c < d$, we never have that $a < c < b < d$ or $c < a < d < b$.

Proposition 3.6.2. *Let $v \leq w$ be permutations where $v \in W_{\max}^K$ and $w = xv$ is a length-additive factorization. Let G be a reduced plabic graph that can be obtained from $G_{v,w}$ by a sequence of moves (M1)-(M3). If $I, J \in \vec{\mathbb{F}}(G)$, then I and J are weakly separated.*

Proof. Recall from Lemma 3.4.12 that $H_{v,w}^{mir}$ is the graph obtained from $B_{w_K, \mathbf{w}}$ by reflecting in the mirror and applying w^{-1} to the boundary vertices. There is a clear one-to-one correspondence between faces of $G_{v,w}$ and faces of $H_{v,w}^{mir}$, and the target labels of corresponding faces in each graph agree. Further, performing a sequence of moves to corresponding faces of $G_{v,w}$ and $H_{v,w}^{mir}$ will result in two graphs with the same target face labels. So instead of considering the plabic graph G , we will consider the plabic graph H we obtain by performing an analogous sequence of moves to $H_{v,w}^{mir}$.

First, we deal with the case when $w = w_0$. From the definition of $H_{v,w}^{mir}$, H_{v,w_0}^{mir} is a normal plabic graph with boundary vertices labeled $1, \dots, n$ going clockwise. It follows immediately from [39, Theorem 1.5] that $\vec{\mathbb{F}}^\bullet(H)$ consists of pairwise weakly separated sets.

Now, suppose $w < w_0$. Note that by construction, $H_{v,w}^{mir}$ can be obtained from H_{v,w_0}^{mir} by adding additional bridges. In other words, $H_{v,w}^{mir}$ is a subgraph of H_{v,w_0}^{mir} , whose boundary labels are inherited from the trips of H_{v,w_0}^{mir} . Thus, one can perform a sequence of moves to this subgraph to obtain H as a subgraph of a reduced plabic graph. The weak separation of target labels of H follow again from [39, Theorem 1.5]. □

This property is important because of the following lemma, which will ensure that square moves on $G_{v,w}$ correspond to valid 3-term Plücker relations.

Lemma 3.6.3. *Let G be a relabeled plabic graph such that the elements of $\vec{\mathbb{F}}^\bullet(G)$ are pairwise weakly separated, and let f be a square face of G whose vertices are all of degree 3. Suppose the trips coming into the vertices of f are $T_{i \rightarrow a}$, $T_{j \rightarrow b}$, $T_{k \rightarrow c}$, and $T_{l \rightarrow d}$ reading clockwise around f (see Figure 3.17). Then a, b, c, d are cyclically ordered.*

Proof. Consulting Figure 3.17, the target labels of faces around f are Rab, Rbc, Rcd, Rad , where R is some $(k-2)$ -element subset of $[n]$ and $Rab := R \cup \{a, b\}$. The fact that Rad and Rbc are weakly separated implies that either a, b, c, d or a, c, b, d is cyclically ordered. The fact that Rab and Rcd are weakly separated implies that the former is true. □

We can now show that if G is a relabeled plabic graph move-equivalent to $G_{v,w}$, square moves on G agree with the categorical mutation of modules in $\mathcal{C}_{v,w}$. This, together with Theorem 3.5.20, completes the proof of Theorem 3.1.7.

Lemma 3.6.4. *Let G be a reduced plabic graph that is move-equivalent to $G_{v,w}$. Suppose that the (target) labeled quiver $Q(G) = \Gamma_U$, for some cluster-tilting module $U \in \mathcal{C}_{v,w}$. If G' is obtained from G by performing a square move at some face F of G , then*

$$Q(G') = \Gamma_{U'}$$

as labeled quivers, where U' denotes the mutation of U at the corresponding indecomposable summand U_F of U .

Proof. The label of the square face F and its surrounding faces are given in Figure 3.17. Here, R is a $(k-2)$ -element subset of $[n]$ and Rac stands for $R \cup \{a, c\}$. Thus, F has label Rac in G and after the mutation it has label Rbd . By Proposition 3.6.2, the target face labels of G are pairwise weakly separated, so by Lemma 3.6.3, a, b, c, d are cyclically ordered. Now, consider the local configuration in Γ_U around the vertex Δ_{Rac} corresponding to the summand U_F of U . By definition of mutation, $U' = U/U_F \oplus U'_F$, where U'_F is defined by the two short exact sequences as follows.

$$0 \longrightarrow U'_F \longrightarrow U_{Rbc} \oplus U_{Rad} \longrightarrow U_F \longrightarrow 0 \qquad 0 \longrightarrow U_F \longrightarrow U_{Rab} \oplus U_{Rcd} \longrightarrow U'_F \longrightarrow 0$$

where we identify summand of U with the labels of the corresponding faces in G . By the properties of the cluster-character map φ this yields the relation

$$\varphi_{U_F} \varphi_{U'_F} = \varphi_{U_{Rbc}} \varphi_{U_{Rad}} + \varphi_{U_{Rab}} \varphi_{U_{Rcd}}.$$

Note that if one of the faces adjacent to F has label $v^{-1}([k])$ then the associated module $U_{v^{-1}([k])}$ is the zero module and $\varphi_{U_{v^{-1}([k])}} = \Delta_{v^{-1}([k])} = 1$ by Remark 3.4.13. In this case, the relation above still holds. Since the two labeled quivers $Q(G)$ and Γ_U coincide, each function $\varphi_{U_E} \in \mathbb{C}[\mathcal{R}_{w_k, w}]$, where E is a face in G , is simply a Plücker coordinate coming from the label of the face. In particular, we have the following.

$$\varphi_{U_F} = \varphi_{Rac} = \Delta_{Rac} \quad \varphi_{U_{Rab}} = \Delta_{Rab} \quad \varphi_{U_{Rbc}} = \Delta_{Rbc} \quad \varphi_{U_{Rcd}} = \Delta_{Rcd} \quad \varphi_{U_{Rad}} = \Delta_{Rad}$$

Therefore, the relation above becomes

$$\Delta_{Rac} \varphi_{U'_F} = \Delta_{Rbc} \Delta_{Rad} + \Delta_{Rab} \Delta_{Rcd}$$

which is precisely a three-term Plücker relation in the corresponding skew Schubert variety. Thus, we conclude that $\varphi_{U'_F} = \Delta_{Rbd}$. This shows that the two labeled quivers $Q(G')$ and $\Gamma_{U'}$ agree. \square

Remark 3.6.5. Since all graphs in Lemma 3.4.12 give rise to the same labeled seed (up to reversing all arrows in the quiver, which does not affect mutation), and a sequence of moves on any one can be translated to a sequence of moves on any other that effects the dual quiver in the same way, Lemma 3.6.4 shows that any reduced plabic graph move-equivalent to a graph in Lemma 3.4.12 gives rise to a seed for $\pi_k(\mathcal{R}_{v, w})$.

The proof of Theorem 3.1.6

We now explain how to deduce Theorem 3.1.6 from Theorem 3.1.7.

Recall that for $v \in W_{\max}^K$, $\pi_k(\mathcal{R}_{v, w_0}) = X_\lambda^\circ$, where $V^\prec(\lambda) = v^{-1}([k])$. The decorated permutation corresponding to $\pi_k(\mathcal{R}_{v, w_0})$ is $v^{-1}w_0$.

Recall also that we can obtain v^{-1} in list notation from λ by labeling the southeast border of λ with $1, \dots, n$ going southwest and first reading the labels of vertical steps going northeast

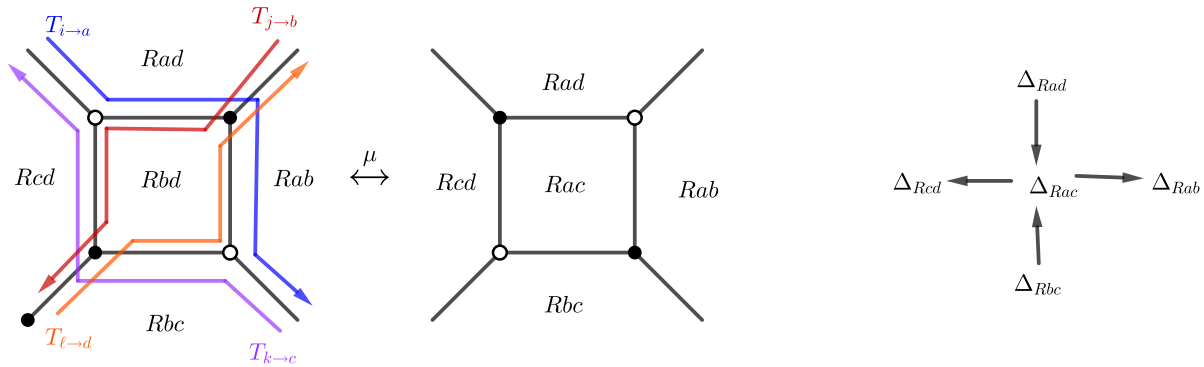

Figure 3.17: Plabic graphs G' and G respectively, and the labeled quiver $Q(G)$

and then reading the labels of the horizontal steps going northeast. To obtain $v^{-1}w_0$, we reverse the order in which we read the border of λ , first reading the labels of horizontal steps going southwest and then reading the labels of the vertical steps going southwest. So $v^{-1}w_0$ is equal to the permutation π_λ^\vee appearing in Theorem 3.1.6.

Let $x := w_0 v^{-1}$. The factorization $w_0 = xv$ is length-additive. Let \mathbf{w}' be a standard reduced expression for $w' := xw_K$. If we take $B_{w_K, \mathbf{w}'}$, apply w_0^{-1} to the boundary vertices, and “reflect in the mirror”, we obtain a graph H_{v, w_0}^{mir} which has trip permutation π_λ^\vee and whose boundary vertices are labeled with $1, \dots, n$ clockwise. According to Theorem 3.5.20 and Lemma 3.4.12, if we label the dual quiver of H_{v, w_0}^{mir} using target labels, we obtain a seed for the coordinate ring of (the affine cone over) X_λ° . And by Remark 3.6.5, if G is any reduced plabic graph move-equivalent to H_{v, w_0}^{mir} (that is, with boundary vertices labeled $1, \dots, n$ clockwise and trip permutation π_λ^\vee), then the (target) labeled dual quiver $Q(G)$ gives a seed.

3.7 Applications

In this section we give applications of Theorem 3.1.6 and Theorem 3.1.7.

The coordinate rings of Schubert and skew-Schubert varieties

Combining Theorem 3.1.6 and Theorem 3.1.7 with [36, Theorem 3.3] and [35], we obtain the following corollary.

Corollary 3.7.1. *Let $v \leq w$, where $v \in W_{\max}^K$ and $w = xv$ is length-additive. Then the cluster algebra $\mathbb{C}[\pi_k(\mathcal{R}_{v,w})]$ is locally acyclic, and thus is finitely generated, normal, locally a complete intersection, and equal to its own upper cluster algebra.*

Combining our result with [16, Theorem 1.2], we find that the quivers giving rise to the cluster structures for Schubert and skew Schubert varieties admit *green-to-red sequences*, which by [24] implies that the cluster algebras have *Enough Global Monomials*. Hence, we have the following corollary.

Corollary 3.7.2. *Let $v \leq w$, where $v \in W_{\max}^K$ and $w = xv$ is length-additive. Then the cluster algebra $\mathbb{C}[\overline{\pi_k(\mathcal{R}_{v,w})}]$ has a canonical basis of theta functions, parameterized by the lattice of g -vectors.*

Skew Schubert varieties whose cluster structure has finite type

In [46], Scott classified the Grassmannians whose coordinate rings have a cluster algebra of finite type. She showed that in general the cluster algebras have infinite type, except in the following cases: the coordinate ring of $\text{Gr}(2, n)$ has a cluster algebra of type A_{n-3} , while the coordinate rings of $\text{Gr}(3, 6)$, $\text{Gr}(3, 7)$, and $\text{Gr}(3, 8)$ have cluster algebras of types D_4 , E_6 , and E_8 , respectively.

It is straightforward to classify for which skew Schubert varieties $\pi_k(\mathcal{R}_{v,w})$ the cluster structure described here is finite type. It depends only on wv^{-1} . We will need the following two facts.

Proposition 3.7.3 ([6]). *Let Q and Q' be orientations of trees T and T' , respectively. If Q can be obtained from Q' by a sequence of mutations, then T and T' are isomorphic.*

Lemma 3.7.4 ([14, Remark 5.10.9]). *Let Q be a quiver and let Q' be a subquiver of Q consisting of some vertices of Q , which inherit being frozen or mutable from Q , and all arrows between them. Then if Q is mutation equivalent to a (disjoint union of) type ADE Dynkin diagram, so is Q' .*

Proposition 3.7.5. *Let $v \leq w$, where $v \in W_{\max}^K$ and $w = xv$ is length-additive. Let $\lambda = \lambda^\vee(x([k]))$ and let λ' be the diagram obtained from λ by removing all boxes that touch the southeast boundary of λ . Then the cluster algebra $\mathcal{A} = \mathbb{C}[\overline{\pi_k(\mathcal{R}_{v,w})}]$ given in Theorem 3.1.7 is*

1. *type A if and only if λ' does not contain a 2×2 rectangle;*
2. *type D if and only if $\lambda' = (i, 2)$ or its transpose for $i \geq 2$;*
3. *type E_6 , E_7 , or E_8 if and only if λ' or its transpose is one of $(3, 3)$, $(3, 2, 1)$, $(4, 3)$, $(4, 2, 1)$, $(3, 3, 1)$, $(5, 3)$, $(5, 2, 1)$, $(4, 4)$, $(4, 2, 2)$.*

In particular, the cluster algebra associated to the Schubert variety X_λ is of finite type if and only if λ' is in the above list.

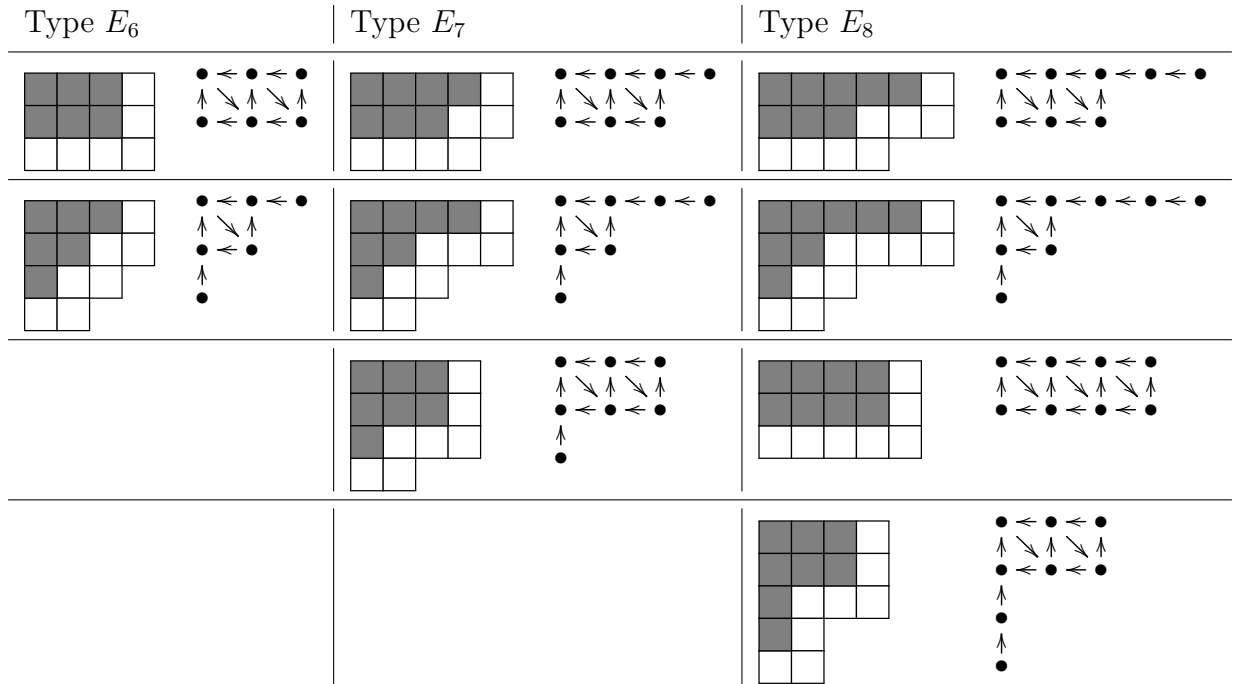

Figure 3.18: Up to transposition, the smallest partitions giving rise to quivers of types E_6, E_7, E_8 , whose mutable parts are shown on the right. The boxes corresponding to mutable vertices are shaded. Adding any number of boxes to the first row or column of these partitions only adds isolated frozen vertices to the quiver, and so also gives rise to a quiver of type E_6, E_7, E_8 .

Proof. 1. The backwards direction follows from the fact that if λ' does not contain a 2×2 rectangle, then $Q_{v,w}$ is an orientation of a path. For the other direction, recall that the mutable part of all type A quivers can be obtained from a triangulation of a polygon [14, Lemma 5.3.1]. It is not hard to see that there is no arrangement of 4 arcs in a triangulation that gives the quiver we draw from a 2×2 rectangle according to Definition 3.3.1, so if λ' contains a 2×2 rectangle as a subdiagram, \mathcal{A} is not type A.

2. The backwards direction follows from inspection of the associated quivers; if one mutates at the vertex in the northwest box, one obtains an orientation of a type D Dynkin diagram. If $|\lambda'| \leq 8$, then necessity follows from direct computation and Proposition 3.7.3. Four partitions of 8 are not finite type (see Figure 3.19), so by Lemma 3.7.4 any partition containing one of these four will not be finite type. The partitions of 9 that are not of type A, are not $(7, 2)$ or its transpose, and do not contain a partition of 8 that is infinite type are shown in Figure 3.19; they are all infinite type. Thus, the only partitions of 9 that are finite type and not type A are $(7, 2)$ and its transpose. From this, we can conclude that \mathcal{A} is type D only if $\lambda' = (i, 2)$ or its tranpose. Indeed,

\mathcal{A} is infinite type if λ' is not type A and contains any partition of 9 that is not $(7, 2)$ or its transpose, or, equivalently, if $\lambda' \neq (i, 2)$ or its transpose.

3. By direct computation, using Proposition 3.7.3. □

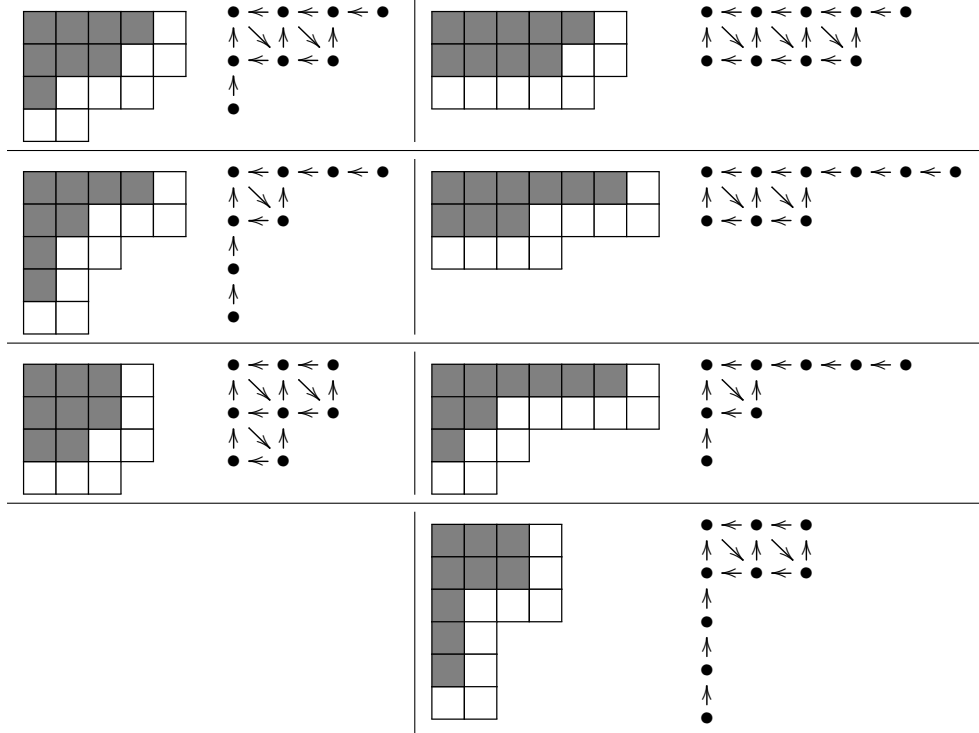

Figure 3.19: These partitions (and their transposes) are the smallest partitions giving rise to quivers of infinite type, whose mutable parts are shown on the right. The boxes corresponding to mutable vertices are shown in green. Adding any number of boxes to the first row or column of these partitions only adds isolated frozen vertices to the quiver, and so also gives rise to a quiver of infinite type.

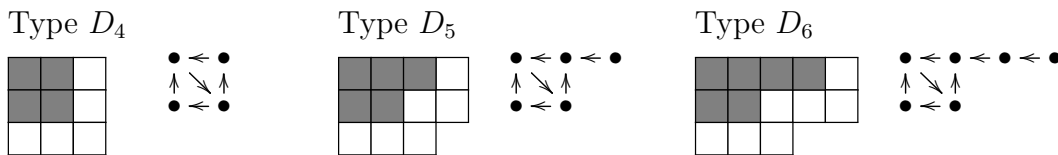

Figure 3.20: A series of Schubert varieties which yield the type D_n cluster algebras.

Applications to the preprojective algebra

As an application of Theorem 3.5.14, we obtain an explicit way to compute the summands of a cluster-tilting module $U_{v,w}$, whereas Leclerc’s definition is constructive. This provides a novel connection between Plücker coordinates and the structure of the summands of $U_{v,\mathbf{w}}$. It is an interesting problem to determine whether this correspondence extends beyond the case of Schubert and skew-Schubert varieties. Such a combinatorial interpretation of the modules would be useful in computing morphisms between the summands of $U_{v,\mathbf{w}}$ for arbitrary (v, \mathbf{w}) . Moreover, given two modules $U, U' \in \mathcal{C}_{v,w}$ that correspond to Plücker coordinates $\Delta_P, \Delta_{P'}$ on the positroid variety $\pi_k(\mathcal{R}_{v,w})$, it is natural to ask whether we can detect an extension between U and U' in terms of the corresponding lattice paths $L'_P, L'_{P'}$. In particular, this would tell us whether two cluster variables $\Delta_P, \Delta_{P'}$ are compatible in the cluster algebra $\mathbb{C}[\overline{\pi_k(\mathcal{R}_{v,w})}]$. This could provide new insights into the representation theory of preprojective algebras.

Moreover, when $w = xv$ is length additive and $v \in W_{max}^K$, we can explicitly write down many of the seeds for the pair (v, w) using the combinatorics of plabic graphs. Thus we find that these cluster algebras have all the nice properties mentioned in Section 3.7 (they are locally acyclic, equal to their upper cluster algebra, admit green-to-red sequences, have a canonical basis of theta functions, etc).

3.8 Skew Schubert varieties

Besides decorated permutations, J-diagrams are another combinatorial object indexing positroid varieties. These diagrams first appear in [7], in the study of the prime spectrum of quantum matrices, and then also in [41], in relation to positroid cell stratification of the totally non-negative Grassmannian. In this section we will give a recipe for the J-diagrams of the *skew Schubert varieties*, i.e. the positroid varieties of the form $\pi_k(\mathcal{R}_{v,w})$, where $v \in W_{max}^K$ and w has a length-additive factorization xv . Recall that in this case, $x \in {}^K W$. The trip permutation of such a positroid is $v^{-1}xv$. While we do not know a combinatorial characterization of these trip permutations, we can describe the corresponding J-diagrams.

The J-diagrams associated to skew Schubert varieties

We first need some preliminary notions, following [29].

For a Young diagram λ that fits inside of a $k \times (n - k)$ rectangle, let $u_\lambda^\nearrow \in {}^K W$ be the Grassmannian permutation of type (k, n) with $u_\lambda^\nearrow([k]) = V^\nearrow(\lambda)$.

Definition 3.8.1. An \oplus -diagram (“o-plus diagram”) O of shape λ is a Young diagram λ that has been filled with 0’s and +’s. We say O is of *type* (k, n) if λ fits into a $k \times (n - k)$ rectangle. An \oplus -diagram is a *J-diagram* (“Le-diagram”) if the “J-property” holds: there is no 0 such that there is a + above it in the same column and a + to its left in the same row (see Figure 3.21).

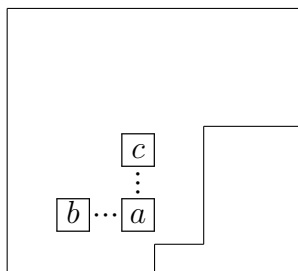

Figure 3.21: The J- property: if $b, c = +$ then $a = +$.

Suppose λ fits inside of a $k \times (n - k)$ rectangle. By Lemma 3.2.1, given a reading order, we can obtain a reduced expression \mathbf{u} for u_λ^\rceil from λ . Fixing a reading order, each \oplus -diagram O of shape λ gives a subexpression \mathbf{r} of \mathbf{u} , obtained by replacing each simple transposition in a box filled with a $+$ by a 1 . The permutation r given by this subexpression does not depend on the reading order [29, Proposition 4.6], so we will denote it by $r(O)$ (for the “reading word” of O).

Note that by [41, Lemma 19.3], O is a J-diagram if and only if \mathbf{r} is a *positive distinguished subexpression* of \mathbf{u} (see Definition 3.9.1).

Proposition 3.8.2. *Let M be a J-diagram of shape λ with reading word r , and let $u = u_\lambda^\rceil$. Then M corresponds to the positroid variety $\pi_k(\mathcal{R}_{u^{-1}w_0, r^{-1}w_0})$*

Proof. By [41, Theorem 19.1], M corresponds to $\pi_k(\mathcal{R}_{r^{-1}, u^{-1}})$. Note that in the complete flag variety, the map $Bx \rightarrow Bxw_0$ gives an isomorphism between $\mathcal{R}_{v,w}$ and \mathcal{R}_{ww_0, vw_0} . The proposition follows immediately. \square

Remark 3.8.3. Let $v \in W_{\max}^K$ and $u \in W_{\min}^K$. The J-diagram of $\pi_k(\mathcal{R}_{v,w_0}) \cong X_{v^{-1}([k])}^\circ$ has shape $\lambda^\vee(v^{-1}([k]))$ and every box contains a $+$. For $u \in W_{\min}^K$, the J-diagram of $\pi_k(\mathcal{R}_{w_K, w_K u}) \cong (X^{u^{-1}([k])})^\circ$ is the $k \times (n - k)$ rectangle where all boxes above $L_{u^{-1}([k])}^\vee$ contain 0 's and all boxes below contain $+$'s.

We can use J-moves to change \oplus -diagrams into J-diagrams.

Definition 3.8.4. [29, Section 5] Suppose O is an \oplus -diagram containing a rectangular sub-diagram where all non-corner boxes are filled with zeros and the northeast and southwest corners are filled with pluses (shown below). If b is 0 , a J-move changes b to $+$ and changes a either from 0 to $+$ or from $+$ to 0 .

a	0	0	0	$+$
0	0	0	0	0
$+$	0	0	0	b



Figure 3.22: Two \mathcal{J} -moves.

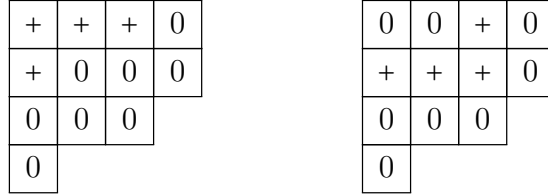

Figure 3.23: On the left, $O_{x,v}$ and on the right, $M(O_{x,v})$ for $x = (1, 2, 4, 7, 3, 5, 6, 8)$ and $v = (4, 3, 8, 2, 7, 6, 1, 5)$.

Note that these are actually the *rectangular* \mathcal{J} -moves of [29, Definition 4.11].

See Figure 3.22 for examples of \mathcal{J} -moves.

The key properties of \mathcal{J} -moves are as follows.

Lemma 3.8.5. [29, Lemma 4.13, Proposition 4.14] *Let O be an \oplus -diagram.*

1. O can be made into a \mathcal{J} -diagram M (“ \mathcal{J} -ified”) by a finite sequence of \mathcal{J} -moves.
2. If O' is related to O by a sequence of \mathcal{J} -moves, then $r(O) = r(O')$.
3. $M =: M(O)$ does not depend on the sequence of \mathcal{J} -moves.

Now, consider $x \in {}^K W$ and $v \in W_{max}^K$ such that $\ell(xv) = \ell(x) + \ell(v)$. Recall from Lemma 3.5.12 that $L_{x([k])}^\nearrow$ lies above $L_{v^{-1}([k])}^\swarrow$. Let λ_x and λ_v be the partitions above $L_{x([k])}^\nearrow$ and $L_{v^{-1}([k])}^\swarrow$, respectively.

Definition 3.8.6. Let $O_{x,v}$ be the \oplus -diagram of shape λ_v with the boxes in λ_x filled with +’s and all other boxes filled with 0’s (see Figure 3.23).

Proposition 3.8.7. $M(O_{x,v})$, the \mathcal{J} -ification of $O_{x,v}$, is the \mathcal{J} -diagram of $\pi_k(\mathcal{R}_{v,xv})$.

Remark 3.8.8. Proposition 3.8.7, together with the definition of $O_{x,v}$ (which is determined by two noncrossing lattice paths in a rectangle, i.e. a skew Young diagram), is the reason that we refer to these positroid varieties as *skew Schubert varieties*.

Proof. Let $M := M(O_{x,v})$. Note that $u_{\lambda_v}^{\nearrow}$ (that is, the Grassmannian permutation of type (k, n) which maps $[k]$ to $V^{\nearrow}(\lambda_v)$) is equal to $w_0 v^{-1}$. The reading word of $O_{x,v}$, and thus of M , is $w_0 v^{-1} x^{-1}$; this follows from the fact that there is a reading order for λ_v which reads the boxes of $\lambda_v \setminus \lambda_x$ before the boxes of λ_x . So by Proposition 3.8.2, M corresponds to $\pi_k(\mathcal{R}_{v,xv})$. \square

3.9 A cluster structure not realizable by relabeled plabic graphs

If $\pi_k(\mathcal{R}_{v,w})$ is not a skew Schubert variety, it is in general impossible to realize the seeds from Leclerc’s construction (Theorem 3.5.4) as labeled quivers coming from (generalized) plabic graph. Indeed, this can fail even in $\text{Gr}(2, 5)$. Before giving an example, we briefly review Leclerc’s construction for the pair (v, \mathbf{w}) , where $v \in W_{\max}^K$, $v < w$ and \mathbf{w} is a reduced expression for w .

Definition 3.9.1. Let $v \leq w$ be permutations and $\mathbf{w} = s_{i_t} \cdots s_{i_1}$ a reduced expression for w . The *positive distinguished subexpression* for v in \mathbf{w} is a reduced expression $\mathbf{v} = v_t \dots v_1$ where $v_j \in \{s_{i_j}, e\}$. We give \mathbf{v} in terms of the products $v_{(j)} := v_j \dots v_2 v_1$. We set $v_{(0)} = e$ and

$$v_{(j)} = \begin{cases} s_{i_j} v_{(j-1)} & \text{if } v v_{(j)}^{-1} s_{i_j} < v v_{(j)}^{-1} \\ v_{(j-1)} & \text{otherwise.} \end{cases}$$

In other words, the positive distinguished subexpression for v is the rightmost subexpression for v in \mathbf{w} , working from right to left.

Let \mathbf{v} be the positive distinguished subexpression for v in $\mathbf{w} = s_{i_t} \cdots s_{i_2} s_{i_1}$. Let $w_{(j)} = s_{i_j} \cdots s_{i_2} s_{i_1}$ for $1 \leq j \leq t$ and let $v_{(j)} = v_j \cdots v_1$ be as in the above definition. Let $J \subset \{1, \dots, t\}$ be the collection of indices j such that $v_j = e$. According to Theorem 3.5.4, the cluster variables in the seed corresponding to (v, \mathbf{w}) are the distinct irreducible factors of $\prod_{j \in J} \Delta_{v_{(j)}^{-1} \{[i_j]\}, w_{(j)}^{-1} \{[i_j]\}}$.

Example 3.9.2. Consider $v = (2, 5, 1, 4, 3)$, $w = (5, 3, 4, 2, 1)$ and the following reduced expression \mathbf{w} for w , where the positive distinguished subexpression for v is in bold:

$$\mathbf{w} = s_1 s_2 \mathbf{s_1} \mathbf{s_3} s_2 \mathbf{s_4} \mathbf{s_3} \mathbf{s_2} s_1.$$

Note that w does not have a length-additive factorization ending in v .

If one computes the generalized minors $\Delta_{v_{(j)}^{-1}([i_j]), w_{(j)}^{-1}([i_j])}$ coming from Theorem 3.5.4, they are not all irreducible. However, if we associate Plücker coordinates to the irreducible factors of these generalized minors (as in Section 3.5), we obtain $\Delta_{13}, \Delta_{23}, \Delta_{14}, \Delta_{45}, \Delta_{15}$.

However, $\{13, 23, 14, 45, 15\}$ cannot be the set of face labels of a relabeled plabic graph for $\text{Gr}(2, 5)$. This comes from the fact that the number 2 appears only once among the set $\{13, 23, 14, 45, 15\}$. In more detail, suppose G were such a relabeled plabic graph. G has no

internal faces and no lollipops. Without loss of generality, G is source-labeled. The face f labeled 23, is adjacent to one other face, labeled 13. So consider the trip T beginning at 2 and ending at j . We know that f is the only face to the left of this trip, and that T must pass through vertices of degree 2 only. Then the trip beginning at j is again T , traveled in the opposite direction. Thus, j must be in the label of every face besides f , a contradiction.

On the other hand, $\{13, 23, 14, 45, 15\}$ is a *subset* of the face labels of a plabic graph for the top cell in $\text{Gr}(2, 5)$, since it is a weakly separated collection. Further, variables in the rectangles seed for the skew-Schubert varieties is always a subset of the face labels of a plabic graph G for the top cell (and the quiver for the rectangles seed is obtained from $Q(G)$ by deleting some vertices and freezing others). One might ask if the seeds given in Leclerc's construction can always be obtained from a plabic graph for the top cell in this way. The following example will show that this is not the case.

Example 3.9.3. Consider $v = (3, 2, 7, 6, 1, 5, 4)$, $w = (7, 6, 4, 2, 5, 3, 1)$, and the following reduced expression \mathbf{w} for w , where the positive distinguished subexpression for v is in bold:

$$\mathbf{w} = \mathbf{s_1 s_2 s_3 s_2 s_1 s_4 s_5 s_4 s_3 s_2 s_6 s_5 s_4 s_3 s_2 s_1 s_5 s_2}$$

The irreducible factors of the generalized minors $\Delta_{v_{(j)}^{-1}([i_j]), w_{(j)}^{-1}([i_j])}$ are Δ_{135} , Δ_{126} , Δ_{235} , Δ_{345} , Δ_{145} , Δ_{467} , Δ_{127} , and Δ_{125} (the first variable is mutable and the others are frozen). Note that 467 and 235 are not weakly separated, so this set of Plücker coordinates cannot be a subset of the face labels of a plabic graph for the top cell.

Chapter 4

Many cluster structures on positroid varieties

The work in this chapter is joint with Chris Fraser, and has appeared on the arXiv [18]. We would like to thank David Speyer and Lauren Williams for helpful conversations on this topic. We would also like to thank Pavel Galashin for pointing us towards [11], and for his plabic tilings applet, which was instrumental for computing many examples. M.S.B acknowledges support by an NSF Graduate Research Fellowship No. DGE-1752814. Any opinions, findings and conclusions or recommendations expressed in this material are those of the authors and do not necessarily reflect the views of the National Science Foundation. C.F. is supported by the NSF grant DMS-1745638.

For open Schubert varieties Π_μ° , the results of the last chapter show that the coordinate ring $\mathbb{C}[\tilde{\Pi}_\mu^\circ]$ is a cluster algebra, and each reduced plabic graph G for Π_μ° determines a seed Σ_G^T for this cluster algebra. An analogous result for arbitrary positroid varieties was proved by Galashin and Lam [19] afterwards, using instead the source seeds Σ_G^S . In this chapter, we study the effect of relabeling the boundary vertices of G by a permutation ρ , in order to better understand the relationship between these two cluster structures. Under suitable hypotheses on the permutation, we show that the relabeled graph G^ρ determines a cluster structure not for Π_μ° but for a different open positroid variety Π_π° . As a key step in the proof, we show that Π_π° and Π_μ° are isomorphic by a nontrivial twist isomorphism. Our constructions yield a family of cluster structures on each open positroid variety, given by plabic graphs with appropriately permuted boundary labels. We conjecture that the seeds in all of these cluster structures are related by a combination of mutations and Laurent monomial transformations involving frozen variables, and establish this conjecture for (open) Schubert and opposite Schubert varieties. As an application, we also show that for certain reduced plabic graphs G , the source seed Σ_G^S and the target seed Σ_G^T are related by mutation and Laurent monomial rescalings.

4.1 Introduction

In this chapter, we turn to the general case of arbitrary positroid varieties. Positroid varieties are irreducible projective subvarieties of the Grassmannian—so named by Knutson–Lam–Speyer [28], who showed they are the algebro-geometric counterparts to Postnikov’s *positroid cells* [41]. They can be defined as closures of the images of Richardson varieties of the full flag variety under the projection to the Grassmannian (as in Section 3.1), or alternatively, as closures of the intersections of (several) cyclically shifted Schubert varieties. Associated to each positroid variety Π is its *open positroid variety* Π° , a smooth Zariski-open subset of the positroid variety defined by the non-vanishing of certain Plücker coordinates. From the perspective of cluster algebras, the natural object to study is the affine cone $\widetilde{\Pi}^\circ$ over the open positroid variety in the Plücker embedding. Positroid varieties in $\text{Gr}(k, n)$ are indexed by permutations of type (k, n) ¹; we write $\widetilde{\Pi}_\pi^\circ$ for the positroid variety indexed by permutation π . As with open Schubert varieties, each positroid variety corresponds to the equivalence class of reduced plabic graphs with trip permutation π .

The motivation for the work in this chapter is the following fact, noted by Muller–Speyer in [36] (and well-known by experts): for G a reduced plabic graph, the source seed Σ_G^S and the target seed Σ_G^T are typically not related by mutation. Moreover, $\mathcal{A}(\Sigma_G^S)$ and $\mathcal{A}(\Sigma_G^T)$ typically have *different* cluster and frozen variables, though as algebras $\mathcal{A}(\Sigma_G^S) = \mathcal{A}(\Sigma_G^T) = \mathbb{C}[\widetilde{\Pi}_\pi^\circ]$. Muller and Speyer conjectured the following, in slightly different language.

Conjecture 4.1.1 ([37, Remark 4.7]). *Let G be a reduced plabic graph. Then Σ_G^S and Σ_G^T are related by a quasi-cluster transformation.*

A quasi-cluster transformation [17] is a sequence of mutations and well-behaved rescalings of cluster variables by Laurent monomials in frozen variables (cf. Section 4.3). If two seeds which give different cluster structures on V are related by a quasi-cluster transformation, then the two cluster structures have the same cluster monomials and define the same positive part of V .

Our first main result establishes many different cluster structures on $\widetilde{\Pi}_\pi^\circ$, which are all determined by seeds from *reabeled plabic graphs* (cf. Definition 4.4.1). Instances of seeds from relabeled plabic graphs appeared previously in [47], in the course of comparing Leclerc’s approach [30] to cluster structures in open positroid varieties with the seeds coming from plabic graphs.

If G is a reduced plabic graph with boundary vertices $1, \dots, n$ and $\rho \in S_n$, the relabeled plabic graph G^ρ is the same planar graph but with boundary vertices relabeled to be $\rho(1), \dots, \rho(n)$ (cf. Figure 4.1)². Each relabeled plabic graph G^ρ gives rise to a pair $\Sigma_{G^\rho}^T = (\overrightarrow{\mathbb{F}}(G^\rho), Q_{G^\rho})$. We make a technical assumption on ρ and the trip permutation π of G^ρ using the partial order \leq_\circ . This partial order is induced by the right weak order on affine

¹Positroid varieties are usually indexed by decorated permutations; our convention in this chapter is all fixed points are colored white (see Section 4.3).

²The trip permutation, target face labels, etc. of G^ρ are computed according to the relabeled boundary.

permutations (cf. Definitions 4.3.21 and 4.3.22), and is the “weak order version” of Postnikov’s *circular Bruhat order*. The condition $\pi\rho \leq_o \pi$ ensures that the Plucker coordinates associated to the boundary faces of G^ρ are non-vanishing on $\widetilde{\Pi}_\pi^\circ$, which is a necessary condition for the seed to determine a cluster structure. Assuming this condition, we characterize when $\Sigma_{G^\rho}^T$ gives a cluster structure on $\widetilde{\Pi}_\pi^\circ$. One of the equivalent conditions is in terms of weak separation; see Definition 4.3.8 for the definition.

Theorem 4.1.2 (Theorem 4.5.24, Corollary 4.6.16). *Suppose $\pi, \rho \in S_n$ such that $\pi\rho \leq_o \pi$ and set $\mu = \rho^{-1}\pi\rho$. Let G be a reduced plabic graph with trip permutation μ , so that G^ρ has trip permutation π . Then the following are equivalent:*

1. $\Sigma_{G^\rho}^T$ is a seed in $\mathbb{C}(\widetilde{\Pi}_\pi^\circ)$ and $\mathcal{A}(\Sigma_{G^\rho}^T) = \mathbb{C}[\widetilde{\Pi}_\pi^\circ]$.
2. The number of faces of G^ρ is $\dim \widetilde{\Pi}_\pi^\circ$. Equivalently, $\dim \widetilde{\Pi}_\pi^\circ = \dim \widetilde{\Pi}_\mu^\circ$.
3. The Plücker coordinates $\vec{\bullet} \mathbb{F}(G^\rho)$ associated to the boundary faces (equivalently, to all faces) of G_ρ are a weakly separated collection.
4. The open positroid varieties $\widetilde{\Pi}_\pi^\circ$ and $\widetilde{\Pi}_\mu^\circ$ are isomorphic.

Moreover, if any (hence, all) of the above conditions hold, the positive part of $\widetilde{\Pi}_\pi^\circ$ determined by $\Sigma_{G^\rho}^T$ is the positroid cell $\widetilde{\Pi}_{\pi, >0}^\circ$.

Figure 4.1 gives an illustration of Theorem 4.1.2.

In stating (2), we have used the well known fact that $\dim \widetilde{\Pi}_G^\circ$ is the number of faces of G . In stating (3), we have used a result of Farber and Galashin [11, Theorem 6.3]. The isomorphism $\widetilde{\Pi}_\pi^\circ \rightarrow \widetilde{\Pi}_\mu^\circ$ in (4) is a generalization of the Muller-Speyer *twist automorphism* of an open positroid variety [37].

Theorem 4.1.2 provides many seeds $\Sigma_{G^\rho}^T$ which give a cluster structure on $\widetilde{\Pi}_\pi^\circ$. When $\widetilde{\Pi}_\pi^\circ$ is a Schubert or opposite Schubert variety, the set of boundaries ρ which give seeds for $\widetilde{\Pi}_\pi^\circ$ is the \leq_o -order ideal below π^{-1} (Proposition 4.7.11). For other π , it is some subset of this order ideal, picked out by a length condition (Definition 4.7.5).

Among the seeds covered by Theorem 4.1.2 are the target seed Σ_H^T and the source seed Σ_H^S for H a usual plabic graph with trip permutation π (cf. Remark 4.7.2). The seeds Σ_H^T and $\Sigma_{G^\rho}^T$ are *not* related by mutation unless ρ is the identity. However, we conjecture the following, which is a direct generalization of Conjecture 4.1.1.

Conjecture 4.1.3. *Suppose H is a plabic graph with trip permutation π , and G^ρ is a re-labeled plabic graph with trip permutation π satisfying the conditions of Theorem 4.1.2. Then the seeds Σ_H^T and $\Sigma_{G^\rho}^T$ are related by quasi-cluster transformations.*

We emphasize that in general, if Σ and Σ' give two different cluster structures on a variety, they may not be related by quasi-cluster transformations. Zhou [50] gives an example of this for the cluster algebra of the Markov quiver.

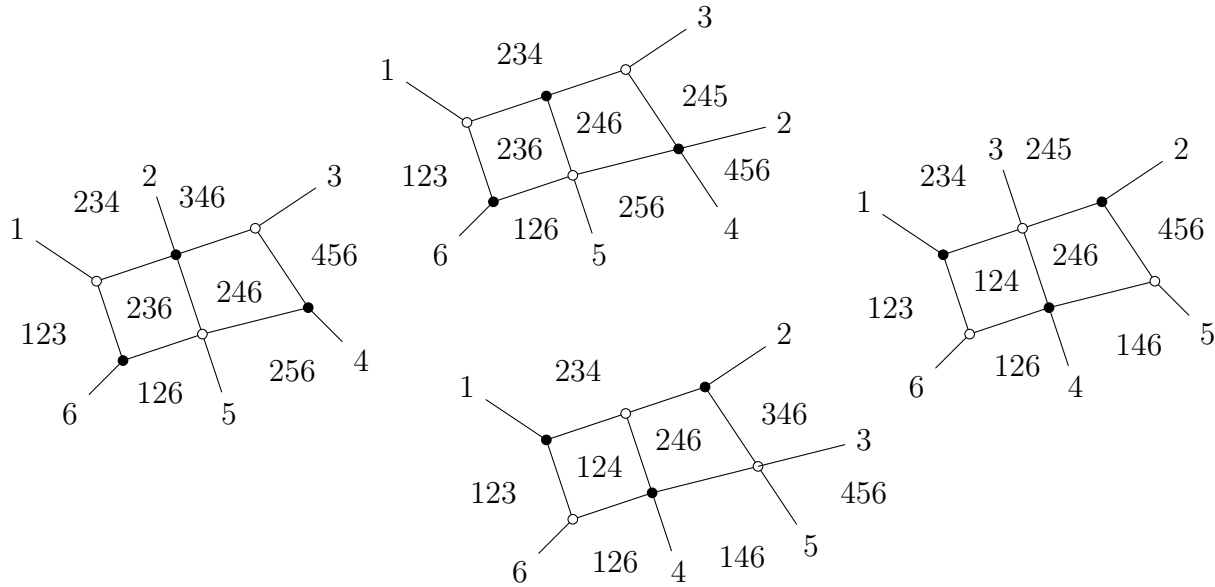

Figure 4.1: The left graph is a reduced plabic graph with trip permutation $\pi = 465213$. It encodes an open positroid variety $\tilde{\Pi}_\pi^\circ$. The three graphs on the right are relabeled plabic graphs with trip permutation π . Ignoring the permuted boundary labels, the four plabic graphs represent four *different* open positroid varieties, isomorphic to each other by Theorem 4.5.24. The face labels of each graph together with the dual quiver give seeds which determine 4 different cluster structures on $\tilde{\Pi}_\pi^\circ$. These four seeds are related by quasi-cluster transformations.

We remark that when the conclusion of Conjecture 4.1.3 holds, each seed $\Sigma_{G^\rho}^T$ can be rescaled to give a seed in $\mathcal{A}(\Sigma_H^T)$ whose cluster variables are Plücker coordinates times a Laurent monomial in frozen variables. So the seeds $\Sigma_{G^\rho}^T$ are (conjecturally) a source for seeds in $\mathcal{A}(\Sigma_H^T)$ whose clusters are Plücker coordinates times units. In general $\mathcal{A}(\Sigma_H^T)$ may contain very few seeds from usual plabic graphs, so we view relabeled plabic graphs as a (conjectural) source for a much larger class of seeds in $\mathcal{A}(\Sigma_H^T)$ which are combinatorially well-understood.

We establish Conjecture 4.1.3 completely for Schubert and opposite Schubert varieties.

Theorem 4.1.4 (Theorem 4.7.12). *Suppose $\tilde{\Pi}_\pi^\circ$ is an open Schubert or opposite open Schubert variety. Then Conjecture 4.1.3 holds. In particular, for H a reduced plabic graph with trip permutation π , the source seed Σ_H^S and the target seed Σ_H^T are related by a quasi-cluster transformation.*

We also give partial results towards Conjecture 4.1.3 for arbitrary open positroid varieties in Theorem 4.7.4. From these results, we obtain a positive answer to Conjecture 4.1.1 for $\tilde{\Pi}_\pi^\circ$ where π is *toggle-connected* (cf. Definition 4.7.5).

Theorem 4.1.5 (Corollary 4.7.8). *Suppose $\pi \in S_n$ is toggle-connected, and let H be a reduced plabic graph with trip permutation π . Then the source seed Σ_H^S and the target seed Σ_H^T are related by a quasi-cluster transformation.*

Outline. In Section 4.2, we provide background on open positroid varieties, as well as bounded affine permutations and the partial order \leq_o , following [41, 28, 46]. We also recall quasi-cluster transformations [17]. Section 4.4 introduces the main players: relabeled plabic graphs and Grassmannlike necklaces. Section 4.5 introduces Theorems 4.5.14 and 4.5.19. Section 4.6 establishes isomorphisms of open positroid varieties via twist maps. It assumes some familiarity with the main constructions in [37]. Section 4.7 introduces Theorem 4.7.4 concerning toggle-connected positroids, and gives examples of families of toggle-connected positroids. Section 4.8 collects some longer proofs.

4.2 Background on cluster algebras and positroids

4.3 Positroid varieties

One way to define positroid varieties is as projections of open Richardson varieties in the full flag variety to the Grassmannian $\text{Gr}(k, n)$, as we saw in Section 3.1. Knutson–Lam–Speyer [28] gave an alternate definition using the combinatorics of positroids developed by Postnikov [41] (and show that the two definitions agree). We review their definition here.

A real $k \times n$ matrix M is *totally nonnegative* if $\Delta_I(M) \geq 0$ for all $I \in \binom{[n]}{k}$. A collection of k -subsets $\mathcal{M} \subset \binom{[n]}{k}$ is a *positroid* if it is the column matroid of a totally nonnegative matrix; i.e., if there exists a real matrix M such that $\Delta_I(M) > 0$ for $I \in \mathcal{M}$ and $\Delta_J(M) = 0$ for $I \notin \mathcal{M}$. The *closed positroid variety* $\Pi_{\mathcal{M}}$ is the subvariety of $\text{Gr}(k, n)$ whose homogeneous ideal is generated by $\{\Delta_I : I \notin \mathcal{M}\}$ [28]. That is,

$$\Pi_{\mathcal{M}} = \{x \in \text{Gr}(k, n) : \Delta_I(x) = 0 \text{ for all } I \notin \mathcal{M}\}.$$

This chapter is concerned with the *open positroid variety* $\Pi^\circ \subset \Pi$, a Zariski-open subset of Π which we will define after reviewing more combinatorial objects indexing positroids.

Combinatorial objects that index positroids

Positroids are naturally labeled by several families of combinatorial objects. We focus on *Grassmann necklaces* here, which are easily in bijection with the decorated permutations defined in Definition 2.2.4. These objects and the results in this section are due to Postnikov [41] unless otherwise noted.

We make the following expositional choice, which streamlines the combinatorial background and also the statements of our results. We will only give the definitions for *loopless* positroids. A positroid $\mathcal{M} \subset \binom{[n]}{k}$ is *loopless* if for every $i \in [n]$, there exists an $I \in \mathcal{M}$ with

$i \in I$. If a positroid is not loopless, than one can work over the smaller ground set $[n] \setminus \{i\}$ without affecting any of the combinatorial or algebraic structures below in a significant way. Geometrically, if a positroid \mathcal{M} has a loop i , then $k \times n$ matrix representatives for points in $\Pi_{\mathcal{M}}^{\circ}$ will have the zero vector in column i . One can project away the i th column and work instead with an isomorphic positroid subvariety of $\text{Gr}(k, n - 1)$.

The first combinatorial object indexing positroids gives rise to frozen variables in the cluster structure(s) on $\tilde{\Pi}^{\circ}$.

Definition 4.3.1. A forward *Grassmann necklace* of type (k, n) is an n -tuple $\vec{I} = (\vec{I}_1, \dots, \vec{I}_n)$ in $\binom{[n]}{k}$ such that for every $a \in [n]$, one has $a \in \vec{I}_a$ and $\vec{I}_{a+1} = \vec{I}_a \setminus a \cup \pi(a)$ for some $\pi(a) \in [n]$.

Dually, a *reverse Grassmann necklace* of type (k, n) is an n -tuple $\tilde{I} = (\tilde{I}_1, \dots, \tilde{I}_n)$ in $\binom{[n]}{k}$ such that for all $a \in [n]$, one has $a \in \tilde{I}_a$ and $\tilde{I}_{a-1} = \tilde{I}_a \setminus a \cup \sigma(a)$ for some $\sigma(a) \in n$.

Remark 4.3.2. The objects just defined might more properly called *loopless Grassmann necklaces*, because they correspond bijectively with loopless positroids. We will drop the adjective loopless.

Definition 4.3.3. A permutation $\pi \in S_n$ has *type* (k, n) if $|\{a \in [n] : a \leq \pi^{-1}(a)\}| = k$.

If \vec{I} is a forward Grassmann necklace, then it follows from the definition that the map $a \mapsto \pi(a)$ is a permutation of $[n]$. Moreover, the permutation π determines the necklace \vec{I} . One has

$$\vec{I}_1 = \{a \in [n] : a \leq \pi^{-1}(a)\} \tag{4.3.1}$$

and the remainder of the necklace can be computed from the data of I_1 and π using the necklace condition. This establishes a bijection between (loopless) forward Grassmann necklaces of type (k, n) and permutations of type (k, n) .

Dually, for a reverse Grassmann necklace \tilde{I} , the map $i \mapsto \sigma(i)$ is a permutation of $[n]$, and a similar recipe allows one to recover \tilde{I} from the permutation σ .

Now we explain how (loopless) positroid subvarieties of $\text{Gr}(k, n)$ are in bijection with Grassmann necklaces of type (k, n) , hence also with permutations of type (k, n) .

For any $i \in [n]$, let $<_i$ denote the order on $[n]$ in which i is smallest and $i - 1$ is largest, i.e. $i <_i i + 1 <_i \dots <_i i - 1$. For a pair of subsets $S = \{s_1 <_i \dots <_i s_k\}, T = \{t_1 <_i \dots <_i t_k\}$, we say that $S \leq_i T$ if $s_j \leq_i t_j$ for all j .

Note that i is maximal in the order $<_{i+1}$.

Definition 4.3.4. Let $\mathcal{M} \subset \binom{[n]}{k}$ be a positroid. For $i \in [n]$, let \vec{I}_i be the $<_i$ -minimal subset of \mathcal{M} , and let \tilde{I}_i be the $<_{i+1}$ -maximal subset of \mathcal{M} . The Grassmann necklace of \mathcal{M} is defined as $\vec{I}_{\mathcal{M}} := (\vec{I}_1, \dots, \vec{I}_n)$ and the reverse Grassmann necklace is $\tilde{I}_{\mathcal{M}} := (\tilde{I}_1, \dots, \tilde{I}_n)$.

Postnikov proved that $\vec{I}_{\mathcal{M}}$ (resp. $\tilde{I}_{\mathcal{M}}$) is in fact a forward (resp. reverse) Grassmann necklace. Moreover, the permutations π and σ encoding $\vec{I}_{\mathcal{M}}$ and $\tilde{I}_{\mathcal{M}}$ are related via $\sigma = \pi^{-1}$.

In our proofs, we frequently use the fact that we can read off the positroid \mathcal{M} from either of its necklaces $\vec{\mathcal{I}}$ and $\overleftarrow{\mathcal{I}}$. This construction is known as Oh’s Theorem [38]:

$$\mathcal{M} = \left\{ S \in \binom{[n]}{k} : S \geq_i \vec{I}_i \text{ for } i \in [n] \right\} = \left\{ S \in \binom{[n]}{k} : S \leq_{i+1} \overleftarrow{I}_i \text{ for } i \in [n] \right\}. \tag{4.3.2}$$

In summary, (loopless) open positroid varieties $\widetilde{\Pi}^\circ \subset \widetilde{\text{Gr}}(k, n)$ can be bijectively labeled by a forward Grassmann necklace $\vec{\mathcal{I}}$ of type (k, n) , or equivalently by a permutation π of type (k, n) , or equivalently by a reverse Grassmann necklace $\overleftarrow{\mathcal{I}}$ of type (k, n) ³. We write $\widetilde{\Pi}_\pi^\circ$, $\vec{\mathcal{I}}_\pi$, and $\overleftarrow{\mathcal{I}}_\pi$ to indicate the open positroid variety, Grassmann necklace, and reverse Grassmann necklace indexed by π .

Open positroid varieties

Let \mathcal{M} be a loopless positroid of type (k, n) . It corresponds to forward Grassmann necklace $\vec{\mathcal{I}}$ of type (k, n) . Then the *open positroid variety* $\Pi_{\mathcal{M}}^\circ$ is the Zariski-open subvariety of $\Pi_{\mathcal{M}}$ on which the necklace variables are non-vanishing:

$$\Pi^\circ = \{x \in \text{Gr}(k, n) : \Delta_I(x) = 0 \text{ for all } I \notin \mathcal{M} \text{ and } \Delta_I(x) \neq 0 \text{ for } I \in \vec{\mathcal{I}}\}.$$

We let $\widetilde{\Pi}, \widetilde{\Pi}^\circ \subset \widetilde{\text{Gr}}(k, n) \subset \mathbb{C}^{\binom{n}{k}}$ be the affine cone over $\Pi, \Pi^\circ \subset \mathbb{P}^{\binom{n}{k}-1}$. The remainder of this chapter studies cluster structure(s) on $\widetilde{\Pi}^\circ$.

Algebraically, the coordinate ring of $\widetilde{\Pi}$ is the quotient $\mathbb{C}[\widetilde{\Pi}] = \mathbb{C}[\text{Gr}(k, n)]/\mathcal{J}$ where \mathcal{J} is the ideal $\langle \Delta_I : I \notin \mathcal{M} \rangle$. The coordinate ring $\mathbb{C}[\widetilde{\Pi}^\circ]$ is the localization of $\mathbb{C}[\widetilde{\Pi}]$ at the Plücker coordinates $\Delta(\vec{\mathcal{I}})$.

Remark 4.3.5. A more geometric definition of open positroid varieties is that they are the varieties obtained by intersecting n cyclically shifted Schubert cells, i.e. by intersecting Schubert cells with respect to the standard ordered basis (e_1, \dots, e_n) and each of its cyclic shifts [28].

Plabic graphs and weak separation

Recall the definition of a reduced plabic graph G , its trip permutation π_G and its target and source face labels $\vec{\mathbb{F}}(G)$ and $\overleftarrow{\mathbb{F}}(G)$ from Definition 2.2.7. We only work with reduced plabic graphs in this chapter, and often omit the adjective. We also assume that G has no isolated boundary vertices. Since we work with loopless positroids, we also assume henceforth that G has no *black lollipops* (interior black vertices of degree one, connected to a boundary vertex).

First, some facts that we will need in the future.

Remark 4.3.6. For reduced graphs G , the number of faces of the graph G is the dimension of $\widetilde{\Pi}_{\pi(G)}^\circ$.

³whose permutation is π^{-1}

Remark 4.3.7. Let F_a be the boundary face of G which is adjacent to boundary vertices $a-1$ and a . Then the face label $\vec{I}^\bullet(F)$ is the a th element of the forward Grassmann necklace: $\vec{I}^\bullet(F_a) = \vec{I}_a \in \vec{\mathcal{I}}_{\pi(G)}$. Likewise, source labels of the boundary faces are the reverse Grassmann necklace $\vec{\mathcal{I}}$ of \mathcal{M} .

The following definition allows us to describe target collections $\vec{\mathbb{F}}^\bullet(G) \subset \binom{[n]}{k}$ intrinsically (i.e., without references to graphs G).

Definition 4.3.8 (Weak separation). A pair of subsets $I, J \in \binom{[n]}{k}$ is *weakly separated* if there is no cyclically ordered quadruple $a < b < c < d$ where $a, c \in I \setminus J$ and $b, d \in J \setminus I$. A *weakly separated collection* $\mathcal{C} \subset \binom{[n]}{k}$ is a collection whose members are pairwise weakly separated.

For a positroid \mathcal{M} , a weakly separated collection $\mathcal{C} \subset \mathcal{M}$ is called *maximal* if $I \in \mathcal{M} \setminus \mathcal{C}$ implies that $\{I\} \cup \mathcal{C}$ is not weakly separated.

Maximal weakly separated collections which contain Grassmann necklaces are exactly the target face labels of plabic graphs.

Theorem 4.3.9 ([39]). *Let \mathcal{M} be a positroid with Grassmann necklace $\vec{\mathcal{I}}$ and decorated permutation π . The following are equivalent.*

1. *The collection $\mathcal{C} \subseteq \mathcal{M}$ is a maximal weakly separated collection containing $\vec{\mathcal{I}}$.*
2. *The collection \mathcal{C} is equal to $\vec{\mathbb{F}}^\bullet(G)$ for some plabic graph G with trip permutation π .*

One can phrase square moves entirely in terms of weakly separated collections as follows.

Definition 4.3.10 (Square move). Let $\mathcal{C} \subset \binom{[n]}{k}$ be a weakly separated collection and $I \in \mathcal{C}$. Suppose there are cyclically ordered $a < b < c < d \in [n]$, and a subset $S \in \binom{[n]}{k-2}$, such that $I = Sac$, and moreover each of $Sab, Sbc, Scd, Sad \in \mathcal{C}$. (We abbreviate $Sac := S \cup \{a, c\}$.) Then $\mathcal{C}' := \mathcal{C} \setminus I \cup (Sbd)$ is again a weakly separated collection. The passage $\mathcal{C} \rightarrow \mathcal{C}'$ is referred to as a *square move* on \mathcal{C} .

Weakly separated collections give an alternate way of proving that all seeds Σ_G^T from reduced plabic graphs G with the same trip-permutation are related by a sequence of moves.

Theorem 4.3.11 ([39]). *Let \mathcal{M} be a positroid with Grassmann necklace $\vec{\mathcal{I}}$. Let $\mathcal{C}_1, \mathcal{C}_2 \subset \mathcal{M}$ be maximal weakly separated collections satisfying $\vec{\mathcal{I}} \subset \mathcal{C}_i$ for $i = 1, 2$. Then \mathcal{C}_2 can be obtained from \mathcal{C}_1 by a finite sequence of square moves (with each intermediate collection \mathcal{C} satisfying $\vec{\mathcal{I}} \subset \mathcal{C} \subset \mathcal{M}$).*

Source and target cluster structures from plabic graphs

Recall the source seed Σ_G^S and target seed Σ_G^T of a reduced plabic graph G (Definition 2.2.9).

Performing a square move at a face Plücker $\vec{I}(F) \in \vec{\mathbb{F}}(G)$ amounts to performing a mutation at the variable $\vec{I}(F)$ in the seed Σ_G^T . We conclude that all seeds $\{\Sigma_G^T : \pi_G = \pi\}$ are mutation-equivalent in $\mathbb{C}[\tilde{\Pi}_\pi^\circ]$. We also have the dual statement for the source seeds.

Theorem 4.3.12 ([19]). *If G has trip permutation π , then the source seed $\Sigma_G^S \subset \mathbb{C}(\tilde{\Pi}_\pi^\circ)$ determines a cluster structure on $\tilde{\Pi}_\pi^\circ$. The positive part $\tilde{\Pi}_{\pi, >0}^\circ$ determined by this cluster structure is the positroid cell $\{x \in \tilde{\Pi}_\pi^\circ : \Delta_I(x) > 0 \text{ for } I \in \mathcal{M}_\pi\}$.*

We call the cluster structure on $\tilde{\Pi}_\pi^\circ$ given by source seeds Σ_G^S the *source cluster structure*.

Remark 4.3.13. Leclerc [30] established that for open Richardson varieties $\mathcal{R}_{v,w} \subset \mathcal{F}\ell_n$, there exists a seed $\Sigma \subset \mathbb{C}(\mathcal{R}_{v,w})$ such that the inclusion $\mathcal{A}(\Sigma) \subseteq \mathbb{C}[\mathcal{R}_{v,w}]$ holds. In some cases, he showed that in fact $\mathcal{A}(\Sigma) = \mathbb{C}[\mathcal{R}_{v,w}]$. Applying any isomorphism $\phi : \mathbb{C}[\mathcal{R}_{v,w}] \rightarrow \mathbb{C}[\tilde{\Pi}^\circ]$, Leclerc’s results imply that $\phi(\mathcal{A}(\Sigma))$ is equal to $\mathbb{C}[\tilde{\Pi}^\circ]$ for some positroid varieties, including Schubert and skew Schubert varieties, and is a cluster subalgebra of $\mathbb{C}[\tilde{\Pi}^\circ]$ in general. For a particular choice of ϕ , Serhiyenko, Williams, and the second author showed that for Schubert varieties, $\phi(\Sigma)$ is a target seed Σ_G^T ; for skew-Schubert varieties, $\phi(\Sigma)$ is $\Sigma_{G^\rho}^T$ for G^ρ a relabeled plabic graph with a particular boundary (c.f. Definition 4.4.1) [47]. Galashin and Lam later showed that, under a different isomorphism $\psi : \mathbb{C}[\mathcal{R}_{v,w}] \rightarrow \mathbb{C}[\tilde{\Pi}^\circ]$, $\psi(\Sigma)$ is a source seed Σ_G^S . They also showed that $\psi(\mathcal{A}(\Sigma))$ is the entire coordinate ring $\mathbb{C}[\tilde{\Pi}^\circ]$.

Remark 4.3.14. Our aesthetic preference is for forward Grassmann necklaces (rather than reverse ones) so we choose to work with target-labeled seeds Σ_G^T rather than source-labeled ones as in Theorem 4.3.12. Using twist maps, one can deduce from Theorem 4.3.12 that the target-labeled seeds also determine a cluster structure on $\tilde{\Pi}_\pi^\circ$, which we call the *target cluster structure*. We give a more general version of this style of argument in Theorem 4.6.15.

A motivating fact for Chapter 4 (observed by Muller-Speyer and Leclerc) is that the seeds Σ_G^T and Σ_G^S are typically *not* mutation-equivalent, i.e. they do not lie in the same seed pattern.

Quasi-equivalent seeds and seed patterns

Muller and Speyer conjectured that the source and target cluster structures are “the same” for an appropriate notion of equivalence in which one is allowed suitable Laurent monomial transformations involving frozen variables. Such a notion was systematized by the first author in [17]). As always, we assume we are in the situation outlined in Remark 2.1.9, and V is a rational affine algebraic variety.

For a seed Σ of rank r and a mutable index $i \in [r]$, consider the *exchange ratio*

$$\hat{y}_i = \prod_{j \in [m]} x_j^{(\text{no. arrows } j \rightarrow i) - (\text{no. arrows } i \rightarrow j)}. \quad (4.3.3)$$

This is the ratio of the two terms on the right hand side of the exchange relation when one mutates at x_i .

Definition 4.3.15 ([17]). Let Σ and Σ' be seeds of rank r in $\mathbb{C}(V)$. Let $\mathbf{x}, \tilde{Q}, x_i, \hat{y}_i$ denote the cluster, quiver, etc. in Σ and use primes to denote these quantities in Σ' . Then Σ and Σ' are *quasi-equivalent*, denoted $\Sigma \sim \Sigma'$, if the following hold:

- The groups $\mathbb{P}, \mathbb{P}' \subset \mathbb{C}[V]$ of Laurent monomials in frozen variables coincide. That is, each frozen variable x'_i is a Laurent monomial in $\{x_{r+1}, \dots, x_m\}$ and vice versa.
- Corresponding mutable variables coincide up to multiplication by an element of \mathbb{P} : for $i \in [r]$, there is a Laurent monomial $M_i \in \mathbb{P}$ such that $x_i = M_i x'_i \in \mathbb{C}(V)$.
- The exchange ratios (4.3.3) coincide: $\hat{y}_i = \hat{y}'_i$ for $i \in [r]$.

Quasi-equivalence is an equivalence relation on seeds.

Seeds Σ, Σ' are related by a *quasi-cluster transformation* if there exists a finite sequence $\underline{\mu}$ of mutations such that $\underline{\mu}(\Sigma) \sim \Sigma'$.

Definition 4.3.16. We say that seed patterns \mathcal{S}_1 and \mathcal{S}_2 are *quasi-equivalent* if there are seeds $\Sigma \in \mathcal{S}_1$ and $\Sigma' \in \mathcal{S}_2$ such that $\Sigma \sim \Sigma'$. Equivalently, \mathcal{S}_1 and \mathcal{S}_2 are quasi-equivalent if some (hence any) pair of seeds $\Sigma_1 \in \mathcal{S}_1$ and $\Sigma_2 \in \mathcal{S}_2$ are related by a quasi-cluster transformation. We also say that the corresponding cluster algebras $\mathcal{A}(\Sigma_1)$ and $\mathcal{A}(\Sigma_2)$ are quasi-equivalent.

By [17, Section 2], if $p \in [r]$ is a mutable vertex, then seeds $\Sigma \sim \Sigma'$ if and only if $\mu_p(\Sigma) \sim \mu_p(\Sigma')$. This justifies the equivalent formulations in the above definition.

Geometrically, replacing a seed Σ by a quasi-equivalent seed Σ' amounts to reparameterizing the domain of the cluster chart $(\mathbb{C}^*)^m \hookrightarrow V$ by a Laurent monomial transformation. This does not change the image of this chart (i.e., the cluster torus).

The following lemma is immediate from the definitions.

Lemma 4.3.17. *If $\mathcal{S}_1, \mathcal{S}_2 \subset \mathbb{C}(V)$ are quasi-equivalent seed patterns, both determining a cluster structure on V , then the cluster algebras $\mathcal{A}(\mathcal{S}_1)$ and $\mathcal{A}(\mathcal{S}_2)$ have the same sets of cluster monomials and give rise to the same notion of totally positive part $V_{>0} \subset V$. Each cluster of $\mathcal{A}(\mathcal{S}_1)$ can be obtained from a cluster of $\mathcal{A}(\mathcal{S}_2)$ by rescaling its cluster variables by appropriate Laurent monomials in frozen variables.*

We remind the reader of Conjecture 4.1.1, which states that the source and target cluster structures on $\tilde{\Pi}_\pi^\circ$ are quasi-equivalent.

Remark 4.3.18. The target and source collections of a plabic graph G are related by a permutation of indices: we have $\vec{I}^\bullet(F) = \pi(\overleftarrow{I}^\bullet(F))$ for any face F . The permutation π determines the automorphism of $\text{Gr}(k, n)$ by column permutation. We warn that this automorphism *does not* preserve the subvariety $\tilde{\Pi}_\pi^\circ$. On the other hand, Muller and Speyer defined a more subtle automorphism $\tilde{\tau}_\pi \in \text{Aut}(\tilde{\Pi}_\pi^\circ)$, the *right twist map*. By straightforward calculation using [37, Proposition 7.13], the pullback of a source seed along $\tilde{\tau}_\pi^2$ is quasi-equivalent to a target seed: one has $(\tilde{\tau}_\pi^2)^*(\Sigma_G^S) \sim \Sigma_G^T$. Thus, establishing Conjecture 4.1.1 is the same as establishing that $\tilde{\tau}_\pi^2 \in \text{Aut}(\tilde{\Pi}_\pi^\circ)$ is a quasi-cluster transformation, or that $\tilde{\tau}_\pi^2$ is a *quasi-automorphism* in the language of [17]. We expect the stronger statement that $\tilde{\tau}_\pi$ is a quasi-cluster transformation.

Affine permutations

The notions of positroid and Grasmann necklace bear cyclic symmetry that is hidden when we label them by permutations π . To make this cyclic symmetry more apparent, we also index positroids by certain affine permutations following [28]. We collect here the basic notions concerning affine permutations for use in our constructions and proofs.

Convention: we use Greek letters $\pi, \rho, \iota, \mu \dots$ for ordinary permutations and use Roman letters f, r, i, m, \dots , for affine permutations.

Definition 4.3.19. Let \tilde{S}_n denote the group of bijections $f: \mathbb{Z} \rightarrow \mathbb{Z}$ which are n -periodic: $f(a + n) = f(a) + n$ for all $a \in \mathbb{Z}$. There is a group homomorphism $\text{av}: \tilde{S}_n \rightarrow \mathbb{Z}$ sending $f \mapsto \frac{1}{n} \sum_{a=1}^n (f(a) - a)$. We denote by $\tilde{S}_n^k := \{f \in \tilde{S}_n: \text{av}(f) = k\}$. We say that $f \in \tilde{S}_n$ is *bounded*⁴ if $a < \pi(a) \leq a + n$ for all $a \in \mathbb{Z}$. We denote by $\text{Bound}(k, n) \subset \tilde{S}_n^k$ those bounded f with $\text{av}(f) = k$.

By n -periodicity, any $f \in \tilde{S}_n$ is determined by its *window notation* $[f(1), \dots, f(n)]$, i.e. its values on $[n] \subset \mathbb{Z}$.

For $f \in \tilde{S}_n$, the *length* of f is

$$\ell(f) := \#\{i \in [n], j \in \mathbb{Z}: i < j \text{ and } f(i) > f(j)\}.$$

We have a group homomorphism $\tilde{S}_n \rightarrow S_n$ sending f to the permutation $\bar{f}: a \mapsto f(a) \pmod n$. The restriction of this map to $\text{Bound}(k, n)$ gives a bijection

$$\text{Bound}(k, n) \rightarrow \{\text{permutations of type } (k, n)\}.$$

If $f \in \text{Bound}(k, n)$, we say that it is the bounded affine permutation *associated to* \bar{f} , and vice versa.

⁴Our definition of bounded differs slightly from the standard definitions since we work with loopless positroids.

One advantage of working with affine permutations is the following. Suppose that $f \in \text{Bound}(k, n)$ is the affine permutation associated to a permutation π . Then

$$\dim \tilde{\Pi}_\pi^\circ = \# \text{ of faces in a graph } G \text{ with trip perm. } \pi = k(n - k) + 1 - \ell(f). \quad (4.3.4)$$

The first of these equalities was already discussed in Section 4.3.

Right weak order on \tilde{S}_n^k

The kernel of the map av , \tilde{S}_n^0 , is a Coxeter group of type \tilde{A}_{n-1} (cf. [4, Section 8.3]). The Coxeter generators are the simple transpositions $s_i = [1, \dots, i + 1, i, \dots, n]$ for $i = 1, \dots, n - 1$, together with $s_0 = [0, 2, \dots, n - 1, n + 1]$. The transpositions $T \subset \tilde{S}_n^0$ are the affine permutations t_{ab} swapping values $a + jn \leftrightarrow b + jn$ for all $j \in \mathbb{Z}$. The Coxeter length function is the restriction of the length function defined above to \tilde{S}_n^0 .

Definition 4.3.20. Let $f, u, v \in \tilde{S}_n$ satisfying $f = uv$. The factorization $f = uv$ is *length-additive* if $\ell(f) = \ell(u) + \ell(v)$.

The Coxeter group \tilde{S}_n^0 is partially ordered by *right weak order* \leq_R . For $f, u \in \tilde{S}_n^0$ and $v = f^{-1}u$, one has $u \leq_R f$ if and only if $f = uv$ is length-additive. Cover relations in the right weak order on \tilde{S}_n^0 correspond to (n-periodically) sorting adjacent values of f . Each such cover relation amounts to right multiplication by an appropriate Coxeter generator s_i .

The cosets of $\tilde{S}_n/\tilde{S}_n^0$ are $\{\tilde{S}_n^k : k \in \mathbb{Z}\}$. We choose $e_k : a \mapsto a + k$ as the distinguished coset representative for \tilde{S}_n^k . The map $\tilde{S}_n^0 \rightarrow \tilde{S}_n^k$ given by $w \mapsto e_k w$ is a length-preserving bijection.

Definition 4.3.21. Suppose $u, f \in \tilde{S}_n^k$, and let $v := u^{-1}f$. Then $u \leq_R f$ if and only if $e_k^{-1}u \leq_R e_k^{-1}f$ in \tilde{S}_n^0 , or, equivalently, if and only if $f = uv$ is length-additive.

The equivalence of the two definitions follows immediately from the fact that $v \in \tilde{S}_n^0$ and that multiplying by e_k does not change length.

Moving down in the right weak order on \tilde{S}_n^k corresponds to (n-periodically) sorting the values of f . The minimal element in (\tilde{S}_n^k, \leq_R) is the permutation e_k . We denote the associated permutation $\bar{e}_k = k + 1 \dots n 1 \dots k$ by ϵ_k .

By (a similar argument to) [28, Lemma 3.6], the subset $\text{Bound}(k, n) \subset \tilde{S}_n^k$ is a lower order ideal of the poset (\tilde{S}_n^k, \leq_R) . That is, if $f \in \text{Bound}(k, n)$ and $g \in \tilde{S}_n^k$ with $g \leq_R f$, then in fact $g \in \text{Bound}(k, n)$.

To streamline theorem statements, we also consider the partial order on permutations of type (k, n) induced by $(\text{Bound}(k, n), \leq_R)$.

Definition 4.3.22. Suppose ι, π are permutations of type (k, n) , with associated affine permutations $i, f \in \text{Bound}(k, n)$, respectively. Then we define $\iota \leq_\circ \pi$ if and only if $i \leq_R f$. The partial order \leq_\circ is the *circular weak order* on permutations of type (k, n) .

Remark 4.3.23. Postnikov defined a circular Bruhat order on permutations of type (k, n) [41, Section 17]. One can define a weak order analog of the circular Bruhat order by removing some cover relations; our circular weak order is the dual of that order.

Finally, we give more details on length-additivity and the right weak order on \tilde{S}_n^k . It has a characterization in terms of left and right associated reflections, as in the \tilde{S}_n^0 case.

For $f \in \tilde{S}_n$, the set of *right associated reflections* of f is

$$T_R(f) := \{t_{a,b} : \ell(ft) < \ell(f)\}.$$

The set of left associated reflections $T_L(f)$ is defined similarly. It is not hard to see that if $i < j$ with $i \in [n]$ and $j \in \mathbb{Z}$ satisfies $f(i) > f(j)$, then $t_{i,j} \in T_R(f)$, and vice versa. We have $|T_R(f)| = |T_L(f)| = \ell(f)$.

Lemma 4.3.24. *Let $x, y \in \tilde{S}_n$. Then $\ell(xy) = \ell(x) + \ell(y)$ if and only if $T_R(x) \cap T_L(y) = \emptyset$.*

Proof. Suppose $\text{av}(x) = p$ and $\text{av}(y) = q$. Then there exist $w, v \in \tilde{S}_n^0$ such that $x = e_p w$ and $y = v e_q$. Because right and left multiplying by e_b does not change length, $\ell(xy) = \ell(x) + \ell(y)$ if and only if $\ell(wv) = \ell(w) + \ell(v)$. It is a standard fact from Coxeter theory that $\ell(wv) = \ell(w) + \ell(v)$ if and only if $T_R(w) \cap T_L(v) = \emptyset$ [4, Exercise 1.13]. Since $T_R(w) = T_R(x)$ and $T_L(v) = T_L(y)$, we are done. \square

The right weak order in \tilde{S}_n^k also has a variety of characterizations in terms of left and right associated reflections, which are exactly analogous to the \tilde{S}_n^0 case. The proofs are routine, so we omit them.

Lemma 4.3.25. *Let $f, x \in \tilde{S}_n^k$. Let $y := x^{-1}f$. The following are equivalent:*

1. $x \leq_R f$
2. $T_L(x) \subseteq T_L(f)$
3. $T_R(y) \subseteq T_R(f)$.

4.4 Relabeled plabic graphs and Grassmannlike necklaces

Plabic graphs with relabeled boundary

Recall that every reduced plabic G for an open positroid variety $\tilde{\Pi}^\circ$ gives rise to two seeds, Σ_G^S and Σ_G^T , both of which determine cluster structures on $\tilde{\Pi}^\circ$.

The main combinatorial object which we explore is a plabic graph whose boundary vertices have been relabeled. These relabeled plabic graphs will be our source for additional seeds in $\mathbb{C}(\tilde{\Pi}^\circ)$.

Definition 4.4.1. Let G be a reduced plabic graph of type (k, n) and $\rho \in S_n$ a permutation. (Thus, G has boundary vertices $1, \dots, n$ in clockwise order.) The *reabeled plabic graph* G^ρ with boundary ρ is the graph obtained by relabeling the boundary vertex i in G with $\rho(i)$. The plabic graph G is the *underlying graph* of G^ρ .

The *trip permutation* π of G^ρ , *target labels* $\vec{I}(F)$ for $F \in G^\rho$, and *target collection* $\vec{\mathbb{F}}(G^\rho) \subset \binom{[n]}{k}$ are defined in the same way as in Section 2.2, taking into account the relabeling of boundary vertices⁵. The *target seed* is $\Sigma_{G^\rho}^T = (\Delta(\vec{\mathbb{F}}(G^\rho)), Q(G))$, with $\Delta_{\vec{I}(F)}$ declared frozen when F is a boundary face.

Although we refer to $\Sigma_{G^\rho}^T$ as the target seed, we are not yet interpreting it as a seed for any particular open positroid variety.

Figure 4.1 shows three examples of reabeled plabic graphs with their target collections. Each of these graphs has trip permutation 465213. The trip permutations of the underlying graphs are 456312, 564123, and 546132 respectively (in the order top center, bottom center, right).

Remark 4.4.2. We have the following relationships between G and G^ρ . If G has trip permutation μ then G^ρ has trip permutation $\pi(G^\rho) = \rho\mu\rho^{-1}$. The face collections are related by $\vec{\mathbb{F}}(G^\rho) = \rho(\vec{\mathbb{F}}(G))$. In particular the boundary faces of G^ρ are given by $\rho(\vec{\mathcal{I}}_\mu)$.

Example 4.4.3. Let G be a reduced plabic graph with trip permutation π . Consider the reabeled graph $G^{\pi^{-1}}$. The trip permutation of $G^{\pi^{-1}}$ is also π , and the face labels $\vec{\mathbb{F}}(G^{\pi^{-1}})$ are $\pi^{-1}(\vec{\mathbb{F}}(G)) = \overleftarrow{\mathbb{F}}(G)$. Thus, the source seed Σ_G^S is equal to the target seed $\Sigma_{G^{\pi^{-1}}}^T$, and so Definition 4.4.1 includes both the target and source seeds of usual plabic graphs.

We adopt the following setup throughout the rest of the chapter. Let π be a permutation of type (k, n) with open positroid variety $\widetilde{\Pi}_\pi^\circ$. Let $\mathbb{P}_\pi \subset \mathbb{C}[\widetilde{\Pi}_\pi^\circ]$ denote the abelian group in the frozen variables $\Delta(\vec{\mathcal{I}}_\pi)$. Let $f \in \text{Bound}(k, n)$ be the affine permutation associated to π .

Let G^ρ be a reabeled plabic graph with trip permutation π , whose underlying plabic graph G therefore has trip permutation $\mu = \rho^{-1}\pi\rho$. The following conditions are clearly necessary for $\Sigma_{G^\rho}^T$ to determine a seed in $\mathbb{C}(\widetilde{\Pi}^\circ)$:

- (P0) [k -subsets] The graph G , or equivalently the permutation μ , has type (k, n) . In particular, μ has an associated affine permutation $m \in \text{Bound}(k, n)$.
- (P1) [Units] If a boundary face of G^ρ has target label I , then Δ_I is a unit in $\mathbb{C}[\widetilde{\Pi}^\circ]$.
- (P2) [Seed size] The underlying graph G has $\dim \widetilde{\Pi}_\pi^\circ$ many faces. Equivalently by (4.3.4), $\ell(m) = \ell(f)$.

⁵That is, if $\rho(i) \rightsquigarrow \rho(j)$ is a trip of G^ρ , then $\pi(\rho(i)) = \rho(j)$, and one puts the value $\rho(j)$ in $\vec{I}(F)$ for every face $F \in G^\rho$ to the left of this trip. Again, $\vec{\mathbb{F}}(G^\rho) := \{\Delta_{\vec{I}(F)} : F \in G^\rho\}$.

The conditions (P0), (P1), and (P2) are certain compatibility conditions between permutations $\pi, \rho \in S_n$. In Section 4.5 we show that (P0) and (P1) hold when $\pi\rho \leq_o \pi$. In Section 4.5 we completely characterize when (P2) holds, assuming that $\pi\rho \leq_o \pi$.

Grassmannlike necklaces

The following combinatorial objects describe the possible boundary faces in a relabeled plabic graph (cf. Lemma 4.4.10).

Definition 4.4.4 (Grassmannlike necklace). A *Grassmannlike necklace* of type (k, n) is an n -tuple $\mathcal{I} = (I_1, \dots, I_n)$ of subsets $I_j \in \binom{[n]}{k}$, with the property that for some permutation $\rho \in S_n$, we have

$$I_{a+1} = I_a \setminus \rho_a \cup \iota_a \text{ for all } a \in [n] \tag{4.4.1}$$

where $\rho_a \in I_a$ for all a ⁶.

The permutation $\rho : a \mapsto \rho_a$ is the *removal permutation* of \mathcal{I} . It follows that the map $\iota : a \mapsto \iota_a$ is also a permutation of $[n]$, called the *insertion permutation*. We define the *trip permutation* of \mathcal{I} as $\pi = \iota\rho^{-1}$, which maps $\rho_a \rightarrow \iota_a$ for all $a \in [n]$.

We write $\mathcal{I} = \mathcal{I}_{\rho, \iota, \pi}$ to summarize that a Grassmannlike necklace \mathcal{I} has removal, insertion, and trip permutations ρ, ι, π . Since any two of these permutations determine the third, we sometimes write $\mathcal{I}_{\bullet, \iota, \pi}$, $\mathcal{I}_{\rho, \bullet, \pi}$ or $\mathcal{I}_{\rho, \iota, \bullet}$ for this necklace.

Remark 4.4.5. Our Definition 4.4.4 is closely related to the cyclic patterns of Danilov, Karzanov and Koshevoy [10] and also of Grassmann-like necklaces as defined by Farber and Galashin [11]. We have borrowed the latter terminology, although we stress that Definition 4.4.4 *does not* require that \mathcal{I} is a weakly separated collection, as was required in [10, 11].

We depict Grassmannlike necklaces by writing

$$\mathcal{I} = I_1 \begin{smallmatrix} \xrightarrow{\iota_1} \\ \xleftarrow{\rho_1} \end{smallmatrix} I_2 \begin{smallmatrix} \xrightarrow{\iota_2} \\ \xleftarrow{\rho_2} \end{smallmatrix} I_3 \begin{smallmatrix} \xrightarrow{\iota_3} \\ \xleftarrow{\rho_3} \end{smallmatrix} \dots \begin{smallmatrix} \xrightarrow{\iota_{n-1}} \\ \xleftarrow{\rho_{n-1}} \end{smallmatrix} I_n \begin{smallmatrix} \xrightarrow{\iota_n} \\ \xleftarrow{\rho_n} \end{smallmatrix} I_1, \tag{4.4.2}$$

i.e., by indicating the removal and insertion permutations in the picture. It is helpful to think of this picture wrapping around cyclically. The trip permutation can be read by reading up the “columns” of this picture.

Example 4.4.6. A forward Grassmann necklace $\vec{\mathcal{I}}_\pi$ is a Grassmannlike necklace with removal permutation the identity and insertion permutation π . A reverse Grassmann necklace $\overleftarrow{\mathcal{I}}_\pi$ is a Grassmannlike necklace with insertion permutation $\iota = 23 \dots n1$ and removal permutation $\pi^{-1}\iota$.

⁶the index a is considered modulo n here and throughout.

Example 4.4.7. Let $\vec{\mathcal{I}}_\pi = (\vec{I}_1, \dots, \vec{I}_n)$ be a reverse Grassmann necklace. It will frequently be convenient for us to consider the Grassmannlike necklace $\vec{\mathcal{I}}_\pi^{(k+1)}$ consisting of the terms of $\vec{\mathcal{I}}$ in the following *shifted order*:

$$\vec{\mathcal{I}}_\pi^{(k+1)} = (\vec{I}_{k+1}, \vec{I}_{k+2}, \dots, \vec{I}_n, \vec{I}_1, \dots, \vec{I}_k). \quad (4.4.3)$$

The insertion permutation of this Grassmannlike necklace is the Grassmannian permutation $\iota = \epsilon_k$ and the removal permutation is $\rho = \pi^{-1}\epsilon_k$.

We also sometimes consider the Grassmannlike necklace $\vec{\mathcal{I}}_\pi^{(n)} := (\vec{I}_n, \vec{I}_1, \dots, \vec{I}_{n-1})$, which has insertion permutation $\iota = \text{id}$ and removal permutation π^{-1} .

We list some basic properties of Grassmannlike necklaces.

Lemma 4.4.8. *Let $\mathcal{S}_{\rho, \iota, \pi} = (I_1, \dots, I_n)$ be a Grassmannlike necklace. Then $\mathcal{S}_{\rho, \iota, \pi}$ is uniquely determined by ρ and ι . In particular,*

$$I_1 = \{a \in [n] : \rho^{-1}(a) \leq \iota^{-1}(a)\} \quad (4.4.4)$$

and the remaining elements are determined from I_1 using ρ , ι , and (4.4.1).

Proof. The only thing to show is (4.4.4). Consider $a \in [n]$. Then a is removed from $I_{\rho^{-1}(a)}$ only and inserted into $I_{\iota^{-1}(a)+1}$ only. This means that a is in I_j for $j = \iota^{-1}(a) + 1, \iota^{-1}(a) + 2, \dots, \rho^{-1}(a)$. This cyclic interval includes 1 exactly when $\rho^{-1}(a) \leq \iota^{-1}(a)$. \square

For a Grassmannlike necklace $\mathcal{S} = (I_1, \dots, I_n)$ and $\sigma \in S_n$, let $\sigma(\mathcal{S}) := (\sigma(I_1), \dots, \sigma(I_n))$.

Lemma 4.4.9. *Let $\mathcal{S}_{\rho, \iota, \pi} = (I_1, \dots, I_n)$ be a Grassmannlike necklace and let μ denote the permutation*

$$\rho^{-1}\iota = \rho^{-1}\pi\rho = \iota^{-1}\pi\iota. \quad (4.4.5)$$

Then $\mathcal{S} = \rho(\vec{\mathcal{I}}_\mu) = \iota(\vec{\mathcal{I}}_\mu^{(n)})$. In particular, $\mathcal{S}_{\rho, \iota, \pi}$ is of type (k, n) if and only if μ is of type (k, n) .

Proof. Let $\vec{\mathcal{I}}_\mu = (\vec{I}_1, \dots, \vec{I}_n)$. Setting $a = \rho(b)$ in (4.4.4), we obtain $I_1 = \{\rho(b) \in [n] : b \leq (\rho^{-1}\iota)^{-1}(b)\}$. This is $\rho(\vec{I}_1)$. Now, $\rho(\vec{I}_{j+1})$ is $\rho(\vec{I}_j) \setminus \rho(a) \cup \rho(\mu(a))$. Since $\mu = \rho^{-1}\iota$, this is exactly the necklace condition, and $\mathcal{S} = \rho(\vec{\mathcal{I}}_\mu)$. The second equality is similar. \square

As we have discussed above, if G^ρ is a relabeled plabic graph whose trip permutation is π , then the permutation (4.4.5) is the trip permutation of the underlying graph G .

Lemma 4.4.10. *Let G^ρ be a relabeled plabic graph of type (k, n) with trip permutation π . Let F_1, \dots, F_n be the boundary faces of G^ρ in clockwise order with F_1 is the face immediately left of vertex $\rho(1)$.*

Then $(\vec{I}^\bullet(F_1), \dots, \vec{I}^\bullet(F_n))$ is the Grassmannlike necklace $\mathcal{S} = \mathcal{S}_{\rho, \bullet, \pi}$. Moreover, every Grassmannlike necklace arises in this way as the boundary face labels of a relabeled plabic graph G^ρ , read clockwise.

Proof. The underlying graph G of G^ρ has trip permutation $\mu := \rho^{-1}\pi\rho$ (Remark 4.4.2). Let $(\vec{I}_1, \dots, \vec{I}_n)$ be the forward Grassmann necklace with permutation μ .

By Remark 4.4.2, $\vec{I}^\bullet(F_j)$ is equal to $\rho(\vec{I}_j)$. By Lemma 4.4.9, this is equal to the j th subset in \mathcal{S} . So $\mathcal{S} = (\vec{I}^\bullet(F_1), \dots, \vec{I}^\bullet(F_n))$.

Conversely, if $\mathcal{S} = \mathcal{S}_{\rho, \iota, \pi}$ is a Grassmannlike necklace, consider any plabic graph G with trip permutation $\rho^{-1}\pi\rho$. The boundary face labels of the relabeled plabic graph G^ρ (which has trip permutation π) will be \mathcal{S} . □

4.5 When relabeled plabic graphs give seeds

Toggles and the units condition

We give a natural sufficient condition for a Grassmannlike necklace to be a unit necklace, i.e. for the boundary face labels of G^ρ to satisfy the k -subsets condition (P0) and the units condition (P1).

Definition 4.5.1 (Unit necklace). Let \mathcal{S} be a Grassmannlike necklace with trip permutation π and let $\mathbb{P}_\pi \subset \mathbb{C}[\tilde{\Pi}_\pi^\circ]$ be the free abelian group of Laurent monomials in the target frozen variables $\Delta(\tilde{\mathcal{I}}_\pi)$. We say \mathcal{S} is a *unit necklace* if $\Delta(\mathcal{S}) \subset \mathbb{P}_\pi$.

Conjecture 4.5.2. *The group of units of the algebra $\mathbb{C}[\tilde{\Pi}_\pi^\circ]$ coincides with the group \mathbb{P}_π .*

The following operation on Grassmannlike necklaces allows us to construct many unit necklaces, starting from the forward Grassmann necklace.

Definition 4.5.3 (Toggling a necklace). Let $\mathcal{S} = \mathcal{S}_{\rho, \iota, \pi}$ be a Grassmannlike necklace satisfying $\rho_{a-1} \neq \iota_a$ and $\rho_a \neq \iota_{a-1}$ for some $a \in [n]$. The operation of *toggling \mathcal{S} at position a* yields a new necklace \mathcal{S}' whose permutations are given by $(\rho', \iota', \pi') = (\rho \cdot s_{a-1}, \iota \cdot s_{a-1}, \pi)$.

In other words, if

$$\mathcal{S} = I_1 \xrightarrow[\rho_1]{\iota_1} I_2 \xrightarrow[\rho_2]{\iota_2} \dots \xrightarrow[\rho_{a-1}]{\iota_{a-1}} I_a \xrightarrow[\rho_a]{\iota_a} \dots \xrightarrow[\rho_{n-1}]{\iota_{n-1}} I_n \xrightarrow[\rho_n]{\iota_n} I_1,$$

then toggling at a produces the Grassmannlike necklace

$$\mathcal{S}' = I_1 \xrightarrow[\rho_1]{\iota_1} I_2 \xrightarrow[\rho_2]{\iota_2} \dots \xrightarrow[\rho_a]{\iota_a} I'_a \xrightarrow[\rho_{a-1}]{\iota_{a-1}} \dots \xrightarrow[\rho_{n-1}]{\iota_{n-1}} I_n \xrightarrow[\rho_n]{\iota_n} I_1,$$

where $I'_a = I_{a-1} \setminus \rho_a \cup \iota_a = I_a \setminus \iota_{a-1} \cup \rho_{a-1}$.

Remark 4.5.4. Toggling does not affect the trip permutation or the type of a Grassmannlike necklace. Toggling at position a is an involution.

Definition 4.5.5. Let $w \neq z, y \neq x \in [n]$ and consider a pair of chords $w \mapsto x$ and $y \mapsto z$ drawn in the circle with boundary vertices $1, \dots, n$. These chords are called *noncrossing* if they do not intersect (including at the boundary). Two noncrossing chords $w \mapsto x$ and $y \mapsto z$ are *aligned* if we either have $w <_w y <_w z <_w x$ or $w <_w x <_w z <_w y$ (or, if $w = x$, we have $w <_w y <_w z$). We say that toggling in position a is *noncrossing* (resp. *aligned*) if the chords $\rho_{a-1} \mapsto \iota_{a-1}$ and $\rho_a \mapsto \iota_a$ are noncrossing (resp. aligned).

Example 4.5.6. Consider the Grassmann necklace of type $(3, 6)$

$$\vec{\mathcal{L}}_\pi = 123 \frac{4}{1} 234 \frac{6}{2} 346 \frac{5}{3} 456 \frac{2}{4} 256 \frac{1}{5} 126 \frac{3}{6} \tag{4.5.1}$$

whose trip permutation and insertion permutation are $\pi = \iota = 465213$ (see the left of Figure 4.1 for a reduced plabic graph with this trip permutation).

The toggles of $\vec{\mathcal{L}}$ at 3 and 5 are aligned, and all other toggles are crossing. Toggling $\vec{\mathcal{L}}$ at 3, we obtain the Grassmannlike necklace Toggling $\vec{\mathcal{L}}$ at 5, we obtain the Grassmannlike necklace

$$\mathcal{S}_1 := 123 \frac{4}{1} 234 \frac{6}{2} 346 \frac{5}{3} 456 \frac{1}{5} 146 \frac{2}{4} 126 \frac{3}{6}. \tag{4.5.2}$$

$$\mathcal{S}_2 := 123 \frac{4}{1} 234 \frac{5}{3} 245 \frac{6}{2} 456 \frac{2}{4} 256 \frac{1}{5} 126 \frac{3}{6}. \tag{4.5.3}$$

Relabeled plabic graphs whose boundaries are these necklaces are shown in the top center and bottom center of Figure 4.1.

For Grassmannlike necklaces which can be obtained from $\vec{\mathcal{L}}_\pi$ by a sequence of noncrossing toggles, we can obtain information about the matroid \mathcal{M}_π directly from $\mathcal{S}_{\bullet, \iota, \pi}$. This is reminiscent of Oh’s theorem describing the positroid \mathcal{M}_π in terms of the Grassmann necklaces, but is a weaker statement.

Lemma 4.5.7 (Proved in Section 4.8). *Let $\mathcal{S} = (I_1, \dots, I_n)$ be a Grassmannlike necklace that can be obtained from the forward Grassmann necklace $\vec{\mathcal{L}}_\pi$ by a finite sequence of noncrossing toggles.*

If $y <_z \pi(z)$ and $y \notin I_{\rho^{-1}(z)}$, then $I_{\rho^{-1}(z)} \setminus z \cup y \notin \mathcal{M}_\pi$. Likewise, if $\pi(z) <_z y$ and $y \in I_{\rho^{-1}(z)}$, then $I_{\rho^{-1}(z)} \setminus y \cup \pi(z) \notin \mathcal{M}_\pi$.

Remark 4.5.8. Suppose that $\mathcal{S} = (I_1, \dots, I_n)$ and let $\mathcal{S}^{(r)} = (I_r, \dots, I_n, I_1, \dots, I_{r-1})$ be a cyclic shift of this necklace. The conclusion of Lemma 4.5.7 is invariant under cyclic shift. Thus, if the conclusion holds for \mathcal{S} , it holds for its cyclic shift $\mathcal{S}^{(r)}$. We use this in the proof of Proposition 4.6.7.

Now, we turn our attention to producing a unit necklace from $\vec{\mathcal{L}}_\pi$ by applying a sequence of toggles. The key ingredient is the following observation.

Remark 4.5.9. Toggling is related to three-term Plücker relations as follows. Consider a generalized necklace $\mathcal{S} = (I_1, \dots, I_n)$ and a position a at which a toggle can be performed,

involving two chords which are not loops. Let $S := I_{a-1} \setminus \{\rho_{a-1}, \rho_a\} \in \binom{[n]}{k-2}$. Nearby the toggle, the subsets I_{a-1}, I_a, I_{a+1} take the form

$$S\rho_{a-1}\rho_a \overset{\iota_{a-1}}{\underset{\rho_{a-1}}{\rightleftharpoons}} S\iota_{a-1}\iota_a \overset{\iota_a}{\underset{\rho_a}{\rightleftharpoons}} S\iota_{a-1}\iota_a.$$

Let $I'_i = S\rho_{i-1}\iota_i$ be the result of toggling, and let $S_1 = S\iota_{i-1}\rho_{i-1}$ and $S_2 = S\iota_i\rho_i$. We have the following Plücker relation in $\mathbb{C}[\text{Gr}(k, n)]$:

$$\Delta_{I_a}\Delta_{I'_a} = \begin{cases} \Delta_{I_{a-1}}\Delta_{I_{a+1}} + \Delta_{S_1}\Delta_{S_2} & \text{if the toggle at } a \text{ is aligned} \\ \Delta_{I_{a-1}}\Delta_{I_{a+1}} - \Delta_{S_1}\Delta_{S_2} & \text{if the toggle at } a \text{ is noncrossing and nonaligned} \\ \Delta_{S_1}\Delta_{S_2} - \Delta_{I_{a-1}}\Delta_{I_{a+1}} & \text{if the toggle at } a \text{ is crossing.} \end{cases} \quad (4.5.4)$$

Proposition 4.5.10. *Suppose that by a finite sequence of noncrossing toggles, we move from the forward Grassmann necklace $\vec{\mathcal{I}}_\pi$ to a Grassmannlike necklace $\mathcal{S} = (I_1, \dots, I_n)$. Let $\mathcal{S}' = (I'_1, \dots, I'_n)$ be the result of performing a noncrossing toggle to \mathcal{S} in position a . Then*

$$\Delta(I'_a) = \frac{\Delta(I_{a-1})\Delta(I_{a+1})}{\Delta(I_a)} \in \mathbb{C}[\widetilde{\Pi}_\pi^\circ] \quad (4.5.5)$$

and \mathcal{S}' is a unit necklace.

Proof. From (4.5.4), it suffices by induction to show that when we perform a noncrossing toggle on \mathcal{S} , either $S_1 \notin \mathcal{M}$ or $S_2 \notin \mathcal{M}$ (using the notation of Remark 4.5.9).

Suppose we wish to perform a noncrossing toggle at the necklace $\mathcal{S} = \mathcal{S}_{\rho, \iota, \pi}$ reachable from $\vec{\mathcal{I}}$ by a sequence of noncrossing toggles. Let $\overset{\pi(a)}{a}$ be the insertion and removal values to the left of the subset which is going to be toggled, i.e. we are toggling at the subset $I_{\rho^{-1}(a-1)+1} \in \mathcal{S}$. Let $L = I_{\rho^{-1}(a)}$ and $R = I_{\rho^{-1}(a)+1}$ so that we are toggling at R , and locally the necklace looks like $L \overset{\pi(a)}{a} R \overset{t}{\underset{\pi^{-1}(t)}{\rightleftharpoons}} X$ for some $t \in [n]$ and $X \in \binom{[n]}{k}$.

Since the toggle is noncrossing, we either have that $\{t, \pi^{-1}(t)\} \subset (a, \pi(a))$ or $\{t, \pi^{-1}(t)\} \subset (\pi(a), a)$, where $(a, \pi(a))$ denotes the cyclic interval $a <_a a+1 <_a \dots <_a \pi(a)$ and similarly for $(\pi(a), a)$.

In the first situation the subset S_2 can be written as $R \setminus \pi(a) \cup t$ with $t <_a \pi(a)$. Hence $S_2 \notin \mathcal{M}_\pi$ via Lemma 4.5.7.

In the second situation we can write $S_1 = L \setminus \pi^{-1}(t) \cup \pi(a)$. Since we are in the second situation, we have $\pi(a) <_a \pi^{-1}(t)$ so that $S_1 \notin \mathcal{M}_\pi$ by Lemma 4.5.7. \square

Example 4.5.11. Consider the Grassmann necklace $\vec{\mathcal{I}}_\pi$ from Example 4.5.6. By Oh's Theorem (4.3.2), the positroid corresponding to π is $\mathcal{M}_\pi = \binom{[6]}{3} \setminus \{345, 156\}$. A reduced plabic graph with trip permutation π is on the left of Figure 4.1.

Performing an aligned toggle on $\vec{\mathcal{I}}_\pi$ at 3 replaces 346 with 245. By a 3-term Plücker relation we have

$$\Delta_{346}\Delta_{245} = \Delta_{234}\Delta_{456} + \Delta_{246}\Delta_{345}.$$

However, Δ_{345} vanishes on $\widetilde{\Pi}_\pi^\circ$, so in $\mathbb{C}[\widetilde{\Pi}_\pi^\circ]$ we have the relation

$$\Delta_{346}\Delta_{245} = \Delta_{234}\Delta_{456}.$$

In other words, the new variable Δ_{245} is the Laurent monomial $\frac{\Delta_{234}\Delta_{456}}{\Delta_{346}}$ in $\mathbb{C}[\widetilde{\Pi}_\pi^\circ]$, which is the monomial transformation (4.5.5). Similarly, toggling $\widetilde{\mathcal{I}}_\pi$ at 5 replaces 256 with 146, and we have $\Delta_{146} = \frac{\Delta_{456}\Delta_{126}}{\Delta_{256}}$ in $\mathbb{C}[\widetilde{\Pi}_\pi^\circ]$.

Though Proposition 4.5.10 holds in the generality of noncrossing toggles, for the rest of this chapter we restrict our attention to aligned toggles. As justification for this we have:

Lemma 4.5.12. *Suppose that $\mathcal{I} = (I_1, \dots, I_n)$ is a weakly separated Grassmannlike necklace whose trip permutation π is a derangement. Then any noncrossing toggle is an aligned toggle.*

Proof. Let $\overset{x}{\rightleftarrows} I_a \overset{z}{\rightleftarrows} \overset{y}{\leftarrow}$ be the chords nearby a noncrossing toggle. By definition of toggle and the derangement assumption, we have $\{w, y\} \cap \{x, z\} = \emptyset$. Thus, $x, z \in I_{a+1} \setminus I_{a-1}$ while $w, y \in I_{a-1} \setminus I_{a+1}$. If the toggle is not aligned, then the numbers w, x, y, z have cyclic order either $w < x < y < z$ or $w < z < y < x$. So I_{a+1} and I_{a-1} are not weakly separated. \square

Thus, if we are interested in staying entirely within the world of weakly separated necklaces, then aligned toggles are all that we need to consider. As a second justification, the set of necklaces that can be reached from $\widetilde{\mathcal{I}}_\pi$ by a sequence of aligned toggles is easy to describe: they are the necklaces $\mathcal{I}_{\bullet, \iota, \pi}$ with $\iota \leq_\circ \pi$, as the next lemma shows.

Lemma 4.5.13. *Let ι, π be permutations of type (k, n) with associated affine permutations $i, f \in \text{Bound}(k, n)$. Consider the Grassmannlike necklace $\mathcal{I} = \mathcal{I}_{\bullet, \iota, \pi}$.*

Suppose $\iota \leq_\circ \pi$. Then the toggle of \mathcal{I} at a is aligned if and only if $is_{a-1} \leq_R f$, or equivalently, if $\iota \overline{s_{a-1}} \leq_\circ \pi$.

Proof. Let f be the bounded affine permutation associated to π , and let $r := f^{-1}i$, so that $f : r(a) \mapsto i(a)$. We are assuming that $i \leq_R f$.

Suppose that $is_{a-1} \leq_R f$. Since the toggle of \mathcal{I} at a and the toggle of $\mathcal{I}_{\bullet, \iota \overline{s_{a-1}}, \pi}$ involve the same chords, we may switch i and is_{a-1} if necessary, and so may assume that $i(a-1) > i(a)$.

This means that $t_{i(a-1), i(a)} \in T_L(i) \subset T_L(f)$, where the last inclusion is by Lemma 4.3.25. Thus, $t_{r(a-1), r(a)} \in T_R(f)$, and in particular $r(a-1) < r(a)$. By the boundedness of f , we have $r(a-1) < r(a) < i(a) < i(a-1) \leq r(a-1) + n$. Reducing modulo n , we have that $\rho_{a-1} <_{\rho_{a-1}} \rho_a <_{\rho_{a-1}} \iota_a <_{\rho_{a-1}} \iota_{a-1}$ (or that $\rho_{a-1} = \iota_{a-1}$ and $\rho_{a-1} <_{\rho_{a-1}} \rho_a <_{\rho_{a-1}} \iota_a$). So the chords $\rho_{a-1} \mapsto \iota_{a-1}$ and $\rho_a \mapsto \iota_a$ are aligned.

Now, suppose the chords $\rho_{a-1} \rightarrow \iota_{a-1}$ and $\rho_a \rightarrow \iota_a$ are aligned. If $i(a-1) > i(a)$, then we have $is_{a-1} <_R i \leq_R f$, so we assume $i(a-1) < i(a)$. Notice that in this case $T_L(is_{a-1}) = T_L(i) \cup \{t_{i(a-1), i(a)}\}$, so it suffices to show that $t_{i(a-1), i(a)} \in T_L(f)$, or equivalently, that $r(a-1) > r(a)$.

Suppose for the sake of contradiction that $r(a-1) < r(a)$. Since f is bounded, we have that $i(a-1) - n \leq r(a-1) < i(a-1)$ and $i(a) - n \leq r(a) < i(a)$. So either $r(a-1) < r(a) < i(a-1) < i(a)$ or $r(a-1) < i(a-1) < r(a) < i(a)$.

In the first case, note that $r(a), i(a-1), i(a) \in [i(a)-n, i(a)]$. Reducing modulo n , we will have $\rho_a <_{\rho_a} \iota_{a-1} <_{\rho_a} \iota_a$ or $\rho_a = \iota_a <_{\rho_a} \iota_{a-1}$. Also, the number ρ_{a-1} cannot satisfy $\rho_{a-1} <_{\rho_a} \iota_{a-1}$. This means that the chords $\rho_{a-1} \rightarrow \iota_{a-1}$ and $\rho_a \rightarrow \iota_a$ are not aligned, a contradiction.

In the second case, by the boundedness of i , $i(a-1), r(a), i(a) \in [a, a+n]$. Reducing modulo n , we will have $\iota_{a-1} <_{\iota_{a-1}} \rho_a <_{\iota_{a-1}} \iota_a$. The only way we can obtain aligned chords is if $\iota_{a-1} \leq_{\iota_{a-1}} \rho_{a-1} <_{\iota_{a-1}} \rho_a$. This is possible only if $i(a-1) \leq r(a-1) + n < r(a)$, or, in other words, if $r(a-1) < r(a) - n$. By the boundedness of f , there is some $b \in (r(a-1), r(a))$ with $f(b) = r(a)$. Because $i(a-1) < r(a) < i(a)$, when we right-multiply f by a sequence of length-decreasing simple transpositions, we never change the relative order of the values $i(a-1), r(a), i(a)$. But by assumption, i can be obtained from f by right-multiplication by such a sequence, and the values $i(a-1), i(a)$ are adjacent in i . This is a contradiction. \square

Combining Proposition 4.5.10 and Lemma 4.5.13, we obtain the following result on unit necklaces.

Theorem 4.5.14. *Let π, ι be permutations of type (k, n) such that $\iota \leq_{\circ} \pi$. Then the Grassmannlike necklace $\mathcal{S} = \mathcal{S}_{\bullet, \iota, \pi}$ is of type (k, n) and is a unit necklace in $\widetilde{\Pi}_{\pi}^{\circ}$. Moreover, $\Delta(\mathcal{S})$ is a basis for the free abelian group $\mathbb{P}_{\pi} \subset \mathbb{C}[\widetilde{\Pi}_{\pi}^{\circ}]$.*

Remark 4.5.15. Theorem 4.5.14 provides us with many n -tuples of Plücker coordinates which are bases for the abelian group $\mathbb{P}_{\pi} \subset \mathbb{C}[\widetilde{\Pi}_{\pi}^{\circ}]$ – we get one such n -tuple for each element in the lower order ideal beneath f in $(\text{Bound}(k, n), \leq_R)$. In particular, we obtain an explicit construction of many Plücker coordinates which are units in $\mathbb{C}[\widetilde{\Pi}^{\circ}]$. Any such Plücker coordinate cannot be a (mutable) cluster variable in any cluster structure on $\widetilde{\Pi}^{\circ}$.

We have the following corollary of Theorem 4.5.14⁷:

Corollary 4.5.16. *Let $\vec{\mathcal{I}} = \vec{\mathcal{I}}_{\pi}$ be a forward Grassmann necklace and let $\tilde{\mathcal{I}}$ be the reverse Grassmann necklace with permutation π^{-1} . Then $\Delta(\tilde{\mathcal{I}})$ is a basis for \mathbb{P}_{π} . That is, the group of Laurent monomials in the target frozen $\Delta(\tilde{\mathcal{I}})$ coincides with group of Laurent monomials in the source frozen $\Delta(\vec{\mathcal{I}})$ inside $\mathbb{C}[\widetilde{\Pi}^{\circ}]$.*

Proof. Recall that $\epsilon_k = \overline{e_k}$ is the Grassmannian permutation $k+1 \cdots n 1 \cdots k$. Because e_k is the minimal element of $\text{Bound}(k, n)$, ϵ_k is the minimal element of \leq_{\circ} , and in particular $\epsilon_k \leq_{\circ} \pi$. The Grassmannlike necklace $\mathcal{S}_{\bullet, \epsilon_k, \pi}$ is the shifted reverse Grassmann necklace $\vec{\mathcal{I}}_{\pi}^{(k+1)}$. By Theorem 4.5.14, we conclude that $\tilde{\mathcal{I}}$ is a unit necklace and that $\Delta(\tilde{\mathcal{I}})$ is a basis for \mathbb{P}_{π} . \square

The seed size condition and the proof of the main theorem

Consider π a permutation of type (k, n) and ρ a permutation such that $\pi\rho \leq_{\circ} \pi$. Let G^{ρ} be a relabeled plabic graph with trip permutation π . The target labels of its boundary faces are $\mathcal{S} = \mathcal{S}_{\rho, \iota, \pi}$, where $\iota = \pi\rho$. By Theorem 4.5.14, \mathcal{S} has type (k, n) , so the k -subsets condition

⁷This was known, but we do not think it has been stated explicitly previously.

(P0) is satisfied. By the same theorem, \mathcal{S} is a unit necklace, and so the boundary face labels of G^ρ satisfy the units condition (P1).

Now, let $\mu := \rho^{-1}\pi\rho = \iota^{-1}\pi\iota$ be the trip permutation of the underlying graph G . It has type (k, n) by Lemma 4.4.9. Let $m \in \text{Bound}(k, n)$ be the bounded affine permutation corresponding to μ . The seed size condition (P2) is that the bounded affine permutations m, f have the same length.

First, we note that the relation $\mu = \iota^{-1}\pi\iota$ can be lifted to a relation among bounded affine permutations, so m can be computed without passing to permutations of type (k, n)

Lemma 4.5.17. *Suppose π, ι are permutations of type (k, n) such that $\iota \leq_\circ \pi$ and set $\mu := \iota^{-1}\pi\iota$. Let $f, i, m \in \text{Bound}(k, n)$ be the bounded affine permutations associated to π, ι, μ , respectively. Then $m = i^{-1}fi$.*

Proof. Because reducing modulo n is a group homomorphism, it's clear that $\overline{i^{-1}fi} = \mu$. It is also clear that $i^{-1}fi \in \tilde{S}_n^k$, so all that remains to prove is that $i^{-1}fi$ is bounded.

Let $r := f^{-1}i \in \tilde{S}_n^0$ so that $i^{-1}fi = r^{-1}f$.

We start with the two line notation for f ; that is, the numerator is f and the denominator is the identity permutation $e_0 \in \tilde{S}_n^0$. Since $i \leq_R f$, we can obtain i in the numerator of this array by repeatedly swapping adjacent numbers $b > a$ in the numerator. We obtain r in the denominator by applying the same sequence of swaps.

Focusing on any particular value $x \in \mathbb{Z}$, using boundedness of f , we see

$$\begin{array}{cccccc} \cdots & \cdots & x & \cdots & \cdots & \\ \cdots & x - n & \cdots & \cdots & x & \end{array}$$

in that order (specifically, x in the numerator appears strictly left of x and weakly right of $x - n$ in the denominator). Also, note that $f(x - n) \leq x < f(x)$. Thus, we will never swap $f(x)$ and x in the numerator, or x and $f(x)$. So the relative order of these three symbols (x in the numerator, $x, x - n$ in the denominator) is preserved for all i and r .

Let a be given. Let $x = i(a)$ be the value in the numerator at position a . By the argument above, the x in the denominator is in a position strictly right of position a . The position of x in the denominator is $r^{-1}(x)$, so we have $a < r^{-1}i(a)$. And the $x - n$ in the denominator is weakly to the left of a , so we have $r^{-1}(i(a) - n) = r^{-1}i(a) - n \leq a$. So $r^{-1}i$ is bounded. \square

Remark 4.5.18. In the situation of Lemma 4.5.17, we have that $i \leq_R f$, so $\ell(m) \leq \ell(f)$ always. This means that a relabeled plabic graph $G^{\pi^{-1}\iota}$ with trip permutation π has at least $\dim \tilde{\Pi}_\pi^\circ$ many faces.

Theorem 4.5.19. *Let π, ι be permutations of type (k, n) such that $\iota \leq_\circ \pi$. Let $f, i \in \text{Bound}(k, n)$ be the bounded affine permutations associated to π and ι , respectively, and let $m := i^{-1}fi$. Then $\ell(m) = \ell(f)$ if and only if the Grassmannlike necklace $\mathcal{S}_{\bullet, \iota, \pi}$ is weakly separated.*

This is the equivalence (1) \Leftrightarrow (2) from the main Theorem 4.5.24. The proof of Theorem 4.5.19 is given in Section 4.8.

Example 4.5.20. Consider the Grassmannlike necklaces $\mathcal{S}_1, \mathcal{S}_2$ from Example 4.5.6. Both are unit necklaces with trip permutation $\pi = 465213$. The bounded affine permutation associated to π is $f = [4, 6, 5, 8, 7, 9]$. For \mathcal{S}_1 , the insertion permutation ι is associated to bounded affine permutation $i = fs_4$. The requirement that $\ell(i^{-1}fi) = \ell(s_4i) = \ell(f)$ is the requirement that the values 4, 5 are sorted in i (which is true.). Theorem 4.5.19 asserts that \mathcal{S}_1 is therefore weakly separated (which can be verified directly).

We give examples of unit necklaces that are not weakly separated in Figure 4.2.

Remark 4.5.21. Let $f \in \text{Bound}(k, n)$. Notice that $e_k^{-1}fe_k \in \text{Bound}(k, n)$ has the same length as f because right or left multiplication by the elements $\{e_b: b \in \mathbb{Z}\}$ does not affect length. Theorem 4.5.19 implies that the Grassmannlike necklace \mathcal{S} with insertion permutation e_k and trip permutation \bar{f} is weakly separated. As remarked previously, \mathcal{S} is the (shifted) reverse Grassmann necklace $\tilde{\mathcal{I}}$ with permutation π^{-1} (see Example 4.4.7); it is well-known that $\tilde{\mathcal{I}}$ is weakly separated.

It turns out (in the setting that $\pi\rho \leq_o \pi$) that the seed size condition (P2) is sufficient to establish that $\vec{\mathbb{F}}^\bullet(G^\rho)$ is a cluster on $\tilde{\Pi}_\pi^\circ$. Before outlining the proof of this, we recall the following result of Farber and Galashin.

Theorem 4.5.22 ([11, Theorem 6.3]). *Let G^ρ be a relabeled plabic graph with trip permutation π , and let $\mathcal{S} = \mathcal{S}_{\rho, \bullet, \pi}$ be the Grassmannlike necklace consisting of target labels of boundary faces of G^ρ . If \mathcal{S} is weakly separated, then so is the target collection $\vec{\mathbb{F}}^\bullet(G^\rho)$.*

Remark 4.5.23. Farber and Galashin prove moreover that the map $\vec{\mathbb{F}}^\bullet(G) \rightarrow \vec{\mathbb{F}}^\bullet(G^\rho)$, i.e. the permutation ρ , is a bijection between maximal weakly separated collections $\mathcal{C} \subset \binom{[n]}{k}$ satisfying $\tilde{\mathcal{I}}_{\rho^{-1}\iota} \subset \mathcal{C} \subset \mathcal{M}_{\rho^{-1}\iota}$ and maximal weakly separated collections \mathcal{C}' satisfying $\mathcal{S} \subset \mathcal{C}' \subset D_{\mathcal{S}}^{\text{in}}$, where $D_{\mathcal{S}}^{\text{in}} \subset \binom{[n]}{k}$ are the k -subsets lying in the convex hull of \mathcal{S} in the plabic tiling (cf. [11, Definition 4.6].)

We now arrive at our main theorem.

Theorem 4.5.24. *Let G^ρ be a relabeled plabic graph with trip permutation π . Let μ be the trip permutation of the underlying plabic graph G . Suppose that $\pi\rho \leq_o \pi$. Let \mathcal{S} be the Grassmannlike necklace given by the target labels of boundary faces of G^ρ .*

Then the following are equivalent:

1. *The number of faces of G^ρ is $\dim \tilde{\Pi}_\pi^\circ$. Equivalently, $\dim \tilde{\Pi}_\mu^\circ = \dim \tilde{\Pi}_\pi^\circ$.*
2. *The Grassmannlike necklace $\mathcal{S}_{\rho, \pi\rho, \pi}$ (equivalently, the target collection $\vec{\mathbb{F}}^\bullet(G^\rho)$) is a weakly separated collection.*
3. *The open positroid varieties $\tilde{\Pi}_\pi^\circ$ and $\tilde{\Pi}_\mu^\circ$ are isomorphic.*

4. The seed $\Sigma_{G^\rho}^T$ determines a cluster structure on $\tilde{\Pi}_\pi^\circ$.

Proof. The equivalence of the two formulations of (1) is Equation (4.3.4). The equivalence of the two formulations of (2) is Theorem 4.5.22.

Conditions (1) and (2) are equivalent by Theorem 4.5.19 and Equation (4.3.4).

Condition (4) and condition (3) both clearly imply (1).

Condition (4) implies (3): assumption (4) says that $\mathbb{C}[\tilde{\Pi}_\pi^\circ] = \mathcal{A}(\Sigma_{G^\rho}^T)$. By Theorem 4.3.12, $\mathbb{C}[\tilde{\Pi}_\mu^\circ] = \mathcal{A}(\Sigma_G^T)$. Since these seeds have the same quiver, the cluster algebras are isomorphic as rings so that (3) holds.

We show that (1) implies (3) in Theorem 4.6.8 below, via a *twist isomorphism* $\tilde{\Pi}_\pi^\circ \rightarrow \tilde{\Pi}_\mu^\circ$ generalizing the twist automorphism of Muller and Speyer [37].

To show that (1) implies (4), we first establish that $\Sigma_{G^\rho}^T$ is a seed in $\mathbb{C}(\tilde{\Pi}_\pi^\circ)$ in Proposition 4.6.12 and then deduce that $\mathcal{A}(\Sigma_{G^\rho}^T) = \mathbb{C}[\tilde{\Pi}_\pi^\circ]$ in Theorem 4.6.15. \square

When ρ is the identity permutation, Theorem 4.5.24 says that target seeds Σ_G^T determine cluster structures in $\tilde{\Pi}_\pi^\circ$ as claimed in Remark 4.3.14.

Remark 4.5.25. When \mathcal{S} is not weakly separated, we see no good way of creating a seed whose frozen variables are \mathcal{S} and whose cluster variables are Plücker coordinates. Perhaps there is a “natural” construction of seeds with frozen variables \mathcal{S} and whose cluster variables are not Plücker coordinates.

4.6 Twist isomorphisms from necklaces

We explain in this section how, in the setting of Theorem 4.5.14, a Grassmannlike necklace \mathcal{S} encodes a twist map *between* two open positroid varieties. If \mathcal{S} satisfies Theorem 4.5.24 (2), this twist map is an isomorphism.

Grassmannlike twist maps

Endow \mathbb{C}^k with an inner product $\langle \cdot, \cdot \rangle$, and let $\text{Mat}^\circ(k, n)$ denote the space of full-rank $k \times n$ matrices. Let $\mathcal{S} = (I_1, \dots, I_n)$ be a Grassmannlike necklace. We use the notation

$$D(\mathcal{S}) = \{M \in \text{Mat}^\circ(k, n) : \Delta_I(M) \neq 0, \text{ for all } I \in \mathcal{S}\}$$

to denote the Zariski-open subset of $k \times n$ matrix space defined by the non-vanishing of Plücker coordinates $\Delta(\mathcal{S})$. We use the same notation $D(\mathcal{S}) \subset \text{Gr}(k, n)$ to denote the image of these matrices in the Grassmannian. For $M \in \text{Mat}^\circ(k, n)$, we use M_a to denote the a th column of M .

Definition 4.6.1 (Twist maps along \mathcal{S}). Let $\mathcal{S} = (I_1, \dots, I_n)$ be a Grassmannlike necklace of type (k, n) with removal permutation ρ and insertion permutation ι . Let $M \in D(\mathcal{S}) \subset \text{Mat}^\circ(k, n)$ have columns M_1, \dots, M_n . Then the *right twist of M along the necklace \mathcal{S}* is

the matrix $\vec{\tau}_{\mathcal{J}}(M) \in \text{Mat}^\circ(k, n)$ whose a th column $\vec{\tau}_{\mathcal{J}}(M)_a$ is the unique vector such that for all $b \in I_a$,

$$\langle (\vec{\tau}_{\mathcal{J}}(M))_a, M_b \rangle = \begin{cases} 1 & \text{if } \rho(a) = b \\ 0 & \text{else.} \end{cases} \quad (4.6.1)$$

Similarly, the *left twist of M along \mathcal{J}* is the matrix $\tilde{\tau}_{\mathcal{J}}(M)$ such that for all a , $\tilde{\tau}_{\mathcal{J}}(M)_a$ is the unique vector such that for all $b \in I_{a+1}$,

$$\langle (\tilde{\tau}_{\mathcal{J}}(M))_a, M_b \rangle = \begin{cases} 1 & \text{if } \iota(a) = b \\ 0 & \text{else.} \end{cases} \quad (4.6.2)$$

Notice that Equations (4.6.1) and (4.6.2) do define unique vectors, since by assumption the columns of M indexed by I_a form a basis of \mathbb{C}^k .

When $\mathcal{J} = \vec{\mathcal{I}}_\pi$, we write $\vec{\tau}_\pi := \vec{\tau}_{\mathcal{J}}$. When $\mathcal{J} = \tilde{\mathcal{I}}_\pi^{(n)}$ (c.f. Example 4.4.7), we write $\tilde{\tau}_\pi := \tilde{\tau}_{\mathcal{J}}$.

The map $\vec{\tau}_\pi$ (restricted to $\tilde{\Pi}_\pi^\circ$) coincides with the *right twist map* $\vec{\tau} \in \text{Aut}(\tilde{\Pi}_\pi^\circ)$ defined by Muller and Speyer [37]⁸. Similarly, $\tilde{\tau}_\pi$ (restricted to $\tilde{\Pi}_\pi^\circ$) coincides with $\tilde{\tau} \in \text{Aut}(\tilde{\Pi}_\pi^\circ)$, also defined in [37]. Muller and Speyer prove that the right and left twist maps are mutual inverses in $\text{Aut}(\tilde{\Pi}_\pi^\circ)$.

Remark 4.6.2. In [37], the right twist map $\vec{\tau}$ is defined as a piecewise-continuous map on $\text{Mat}^\circ(k, n)$, whose domains of continuity are the open positroid varieties. In particular, Muller and Speyer do not fix a Grassmann necklace in their definition. We choose to fix a necklace. As a result, $\vec{\tau}_\pi$ is well-defined on the Zariski-open subvariety $D(\vec{\mathcal{I}}_\pi)$. Likewise, $\tilde{\tau}_\pi$ is well-defined on $D(\tilde{\mathcal{I}}_\pi)$. We stress that the left and right twist maps are not inverses on the larger domain $D(\vec{\mathcal{I}}_\pi) \cap D(\tilde{\mathcal{I}}_\pi)$. We do prove however, that on this domain $\Delta_I(x) = \Delta_I(\vec{\tau}_\pi \circ \tilde{\tau}_\pi(x))$ for *certain* Plücker coordinates $I \in \binom{[n]}{k}$ (cf. Lemma 4.6.14).

An identical argument as the proof of [37, Prop. 6.1] shows that the twist maps in Definition 4.6.1 descend from $\text{Mat}^\circ(k, n)$ to $\text{Gr}(k, n)$.

The next theorem follows by closely analyzing the proof of [37, Prop. 6.6].

Theorem 4.6.3 (Muller-Speyer). *Let π be a permutation of type (k, n) . Then the right twist map $\vec{\tau}_\pi$ descends to a regular map $D(\vec{\mathcal{I}}_\pi) \rightarrow \tilde{\Pi}_\pi^\circ$. Similarly, the left twist map $\tilde{\tau}_\pi$ descends to a regular map $D(\tilde{\mathcal{I}}_\pi) \rightarrow \tilde{\Pi}_\pi^\circ$.*

Proof. Let $\vec{\mathcal{I}} = \vec{\mathcal{I}}_\pi$ and $\tilde{\mathcal{I}} = \tilde{\mathcal{I}}_\pi$.

We already know that $\vec{\tau}_\pi : D(\vec{\mathcal{I}}) \rightarrow \widetilde{\text{Gr}(k, n)}$ is a regular map.

To show that $\vec{\tau}_\pi$ lands in $\tilde{\Pi}_\pi^\circ$ we need to show that all coordinates in $\Delta(\binom{[n]}{k} \setminus \mathcal{M}_\pi)$ vanish on the image and show also that all coordinates in $\Delta(\vec{\mathcal{I}})$ do not vanish. We have the same

⁸generalizing Marsh and Scott's twist map for $\text{Gr}^\circ(k, n)$ [34].

determinantal formula [37, Lemma 6.5] describing Plücker coordinates of $\vec{\tau}_\pi(x)$. Using this formula we see that $\Delta(\vec{\mathcal{I}})$ is non-vanishing on the image (cf. [37, Equation (9)]).

We use the same formula to see that Δ_J vanishes on the the image of $\vec{\tau}_\pi$ when $J \notin \mathcal{M}_\pi$. Let us clarify a confusing point. In the proof of [37, Proposition 6.6], Muller and Speyer argue an implication $i_d \in \vec{I}_{j_c}$, by taking a representative matrix A of $x \in \widetilde{\Pi}^\circ$ and making an argument about linear independence of columns of A . The assumption $x \in \widetilde{\Pi}^\circ$ is more restrictive than the assumption $x \in D(\vec{\mathcal{I}})$. However, the implication $i_d \in \vec{I}_{j_c}$ is a property of the necklace $\vec{\mathcal{I}}_\pi$ and the positroid \mathcal{M}_π , i.e. it is not a property of matrix representative A . The rest of the proof of [37, Proposition 6.6] proceeds without change.

Finally, the map is surjective because it is an automorphism when restricted to $\widetilde{\Pi}^\circ \subset D(\vec{\mathcal{I}})$. The claims about $\vec{\tau}_\pi$ follow by a symmetric argument. \square

A permutation $\rho \in S_n$ determines an automorphism of $\text{Mat}^\circ(k, n)$, and likewise $\text{Gr}(k, n)$, by column permutation:

$$[A_1 \ \cdots \ A_n] \mapsto [A_{\rho(1)} \ \cdots \ A_{\rho(n)}].$$

We denote these automorphisms by the same symbol ρ . This automorphism acts on Plücker coordinates via $\Delta_I(\rho(X)) = \pm \Delta_{\rho(I)}(X)$ where the extra sign \pm is the sign associated with sorting the values $\rho(i_1), \dots, \rho(i_k)$.

The twists along a Grassmannlike necklace can be described completely in terms of the right and left twists $\vec{\tau}_\pi$ and $\bar{\tau}_\pi$, together with column permutations:

Lemma 4.6.4. *Let π be a permutation of type (k, n) , and consider the Grassmannlike necklace $\mathcal{J} = \mathcal{J}_{\rho, \iota, \pi}$. Let $\mu := \rho^{-1}\iota$.*

We have

$$\vec{\tau}_{\mathcal{J}} = \vec{\tau}_\mu \circ \rho \text{ and } \bar{\tau}_{\mathcal{J}} = \bar{\tau}_\mu \circ \iota$$

as rational maps on $\text{Mat}(k, n)$ or $\widetilde{\text{Gr}}(k, n)$. In particular, the image of $\vec{\tau}_{\mathcal{J}}$ and $\bar{\tau}_{\mathcal{J}}$ is contained in $\widetilde{\Pi}_\mu^\circ$.

Proof. First we discuss the equality $\vec{\tau}_{\mathcal{J}} = \vec{\tau}_\mu \circ \rho$. Let $\vec{\mathcal{I}}_\mu = (\vec{I}_1, \dots, \vec{I}_n)$, and $\mathcal{J} = (I_1, \dots, I_n)$. By Lemma 4.4.9, $\rho(\vec{I}_a) = I_a$.

The domain of $\vec{\tau}_\mu \circ \rho$ is $\rho^{-1}(D(\vec{\mathcal{I}}_\mu))$. We have that $\Delta_{\vec{I}_a}(\rho(x)) = \pm \Delta_{\rho(\vec{I}_a)}(x) = \pm \Delta_{I_a}(x)$ for any $x \in \text{Gr}(k, n)$. Thus $\rho^{-1}(D(\vec{\mathcal{I}}_\mu)) = D(\mathcal{J})$, so $\vec{\tau}_\mu \circ \rho$ and $\vec{\tau}_{\mathcal{J}}$ have the same domain of definition.

Let $x \in D(\mathcal{J})$ be represented by the matrix $M \in \text{Mat}(k, n)$, so $\rho(x)$ is represented by the matrix $[M_{\rho(1)} \cdots M_{\rho(n)}]$.

Let δ denote the Kronecker delta. The definition of $\tilde{\tau}_\mu \circ \rho(x)$ is that

$$\langle (\tilde{\tau}_\mu \circ \rho(M))_a, \rho(M)_b \rangle = \delta_{a,b} \text{ for all } b \in \tilde{I}_a, \text{ i.e.} \quad (4.6.3)$$

$$\langle (\tilde{\tau}_\mu \circ \rho(M))_a, M_{\rho(b)} \rangle = \delta_{a,b} \text{ for all } b \in \tilde{I}_a, \text{ i.e.} \quad (4.6.4)$$

$$\langle (\tilde{\tau}_\mu \circ \rho(M))_a, M_s \rangle = \delta_{a, \rho^{-1}(s)} \text{ for all } s \in \rho(\tilde{I}_a), \text{ i.e.} \quad (4.6.5)$$

$$\langle (\tilde{\tau}_\mu \circ \rho(M))_a, M_s \rangle = \delta_{a, \rho^{-1}(s)} \text{ for all } s \in I_a, \text{ i.e.} \quad (4.6.6)$$

$$\langle (\tilde{\tau}_\mu \circ \rho(M))_a, M_s \rangle = \delta_{\rho(a), s} \text{ for all } s \in I_a, \quad (4.6.7)$$

so that the condition defining $(\tilde{\tau}_\mu \circ \rho(M))_a$ is exactly the condition (4.6.1) defining $\tilde{\tau}_{\mathcal{J}}(M)_a$. So $\tau_{\mathcal{J}}$ and $\tilde{\tau}_\mu \circ \rho$ are the same map.

The second equality holds by a similar argument, noting that $\iota(\tilde{I}_a) = I_{a+1}$ by Lemma 4.4.9. \square

To discuss inverses of twists, we need the following notion.

Definition 4.6.5. Let $\mathcal{J} = \mathcal{J}_{\rho, \iota, \pi}$ be a Grassmannlike necklace. The *dual necklace* \mathcal{J}^* is the Grassmannlike necklace with removal permutation ι^{-1} , insertion permutation ρ^{-1} , and trip permutation $\mu = \rho^{-1}\iota$.

By Lemma 4.4.9, if $\mathcal{J} = \mathcal{J}_{\rho, \iota, \pi}$ and the trip permutation π has type (k, n) , then the dual necklace \mathcal{J}^* has type (k, n) .

Example 4.6.6. The dual necklace of a Grassmann necklace $\tilde{\mathcal{I}}_\pi$ is the necklace $\tilde{\mathcal{I}}_\pi^{(n)}$.

Proposition 4.6.7. Let π be a permutation of type (k, n) , and let $\mathcal{J} = \mathcal{J}_{\rho, \iota, \pi}$ be a Grassmannlike necklace, with dual \mathcal{J}^* . Let $\mu := \rho^{-1}\iota$. Let $\epsilon_r \in S_n$ be the permutation $\epsilon_r : a \mapsto a + r$ (taken modulo n).

Suppose that for some $r \in [n]$, we have $\iota \circ \epsilon_r \leq_o \pi$, and further that \mathcal{J}^* is a unit necklace in $\tilde{\Pi}_\mu^\circ$.

Then on $\tilde{\Pi}_\pi^\circ \subset D(\mathcal{J})$, both compositions

$$\tilde{\tau}_{\mathcal{J}^*} \circ \tilde{\tau}_{\mathcal{J}} \text{ and } \tilde{\tau}_{\mathcal{J}^*} \circ \tilde{\tau}_{\mathcal{J}}$$

are the identity map $id_{\tilde{\Pi}_\pi^\circ}$.

Proof. Suppose $\mathcal{J} = (I_1, \dots, I_n)$. The Grassmannlike necklace with insertion permutation $\iota \circ \epsilon_r$ and removal permutation $\rho \circ \epsilon_r$ is a cyclic shift $\mathcal{J}^{(r+1)} = (I_{r+1}, \dots, I_n, I_1, \dots, I_r)$ of \mathcal{J} . The two necklaces have the same trip permutation, π . By Theorem 4.5.14, if $\iota \circ \epsilon^r \leq_o \pi$ then \mathcal{J} is a unit necklace in $\tilde{\Pi}_\pi^\circ$ (since this is true of the shifted necklace).

This means that $\tilde{\Pi}_\pi^\circ$ is indeed a subset of $D(\mathcal{J})$. By Lemma 4.6.4, the image of $\tilde{\tau}_{\mathcal{J}}$ and $\tilde{\tau}_{\mathcal{J}^*}$ are both contained in $\tilde{\Pi}_\mu^\circ$. By assumption, \mathcal{J}^* is a unit necklace, so $\tilde{\tau}_{\mathcal{J}^*}$ and $\tilde{\tau}_{\mathcal{J}^*}$ are defined on $\tilde{\Pi}_\mu^\circ$. In particular, the compositions are well-defined.

We focus on the composition $\tilde{\tau}_{\mathcal{J}^*} \circ \tilde{\tau}_{\mathcal{J}}$. Note that by Lemma 4.6.4 and the definition of \mathcal{J}^* , $\tilde{\tau}_{\mathcal{J}^*} = \tilde{\tau}_\pi \circ \rho^{-1}$. So the image of the composition is contained in $\tilde{\Pi}_\pi^\circ$.

Let $M \in \widetilde{\Pi}_\pi^\circ$ be given. We would like to show that M is the image of $\rho^{-1} \circ \tilde{\tau}_\mu \circ \rho(M)$ under $\tilde{\tau}_\pi$.

Rewriting the equality (4.6.7) in terms of $b = \rho(a)$, we have

$$\langle (\rho^{-1} \circ \tilde{\tau}_\mu \circ \rho(M))_b, M_s \rangle = \delta_{b,s} \text{ for all } s \in I_{\rho^{-1}(b)} \text{ and for all } b. \quad (4.6.8)$$

We need to show that M satisfies the defining equalities of $\tilde{\tau}_\pi(\rho^{-1} \circ \tilde{\tau}_\mu \circ \rho(M))$, which are the equalities

$$\langle (\rho^{-1} \circ \tilde{\tau}_\mu \circ \rho(M))_b, M_s \rangle = \delta_{b,s} \text{ for all } b \in \tilde{I}_s \text{ and for all } s. \quad (4.6.9)$$

Noting that $b \in I_{\rho^{-1}(b)}$ from the necklace property, we can set $s = b$ in (4.6.8) and conclude that (4.6.9) holds when $b = s$. Equation (4.6.8) also implies that (4.6.9) holds for $b \in \tilde{I}_s \setminus s$ when $s \in I_{\rho^{-1}(b)}$.

It remains to show that when $b \in \tilde{I}_s \setminus s$ and $s \notin I_{\rho^{-1}(b)}$, then $(\rho^{-1} \circ \tilde{\tau}_\mu \circ \rho(M))_b$ is perpendicular to M_s . By (4.6.8), it would suffice to show that M_s is in the span of $\{M_a : a \in I_{\rho^{-1}(b)} \setminus b\}$.

To show that this is true, we apply Lemma 4.5.7 to $I_{\rho^{-1}(b)}$ with $z = b$ and $y = s$. Note that we can apply this lemma to \mathcal{S} since it holds for $\mathcal{S}^{(r+1)}$, cf. Remark 4.5.8. The hypothesis of the lemma requires that that we show $s <_b \pi(b)$. Since $b \in \tilde{I}_s$, we have that $M_b \notin \text{span}(M_{b+1}, \dots, M_s)$. On the other hand, from the definition of $\pi(b)$, we have $M_b \in \text{span}(M_{b+1}, \dots, M_{\pi(b)})$. It follows that $s <_b \pi(b)$. So by Lemma 4.5.7, we have $I_{\rho^{-1}(b)} \setminus b \cup s \notin \mathcal{M}_\pi$, or in other words, M_s is in the span of $\{M_a : a \in I_{\rho^{-1}(b)} \setminus b\}$ (since these vectors are independent).

A symmetric argument shows that the second composition is the identity on $\widetilde{\Pi}_\pi^\circ$. □

Let $\iota, \pi, \mu, \mathcal{S}$ be as in Proposition 4.6.7, and let $f, m \in \text{Bound}(k, n)$ be the bounded affine permutations corresponding to π and μ , respectively. We always have $\ell(m) \leq \ell(f)$ (c.f. Remark 4.5.18), hence $\dim \widetilde{\Pi}_\mu^\circ \geq \dim \widetilde{\Pi}_\pi^\circ$. But by Theorem 4.5.19, equality holds only when \mathcal{S} is weakly separated, which is not always the case (cf. Figure 4.2). So $\tilde{\tau}_\mathcal{S} : \widetilde{\Pi}_\pi^\circ \rightarrow \widetilde{\Pi}_\mu^\circ$ and $\tilde{\tau}_\mathcal{S} : \widetilde{\Pi}_\mu^\circ \rightarrow \widetilde{\Pi}_\pi^\circ$ are certainly not always isomorphisms. Our next result says that they are isomorphisms whenever their domain and codomain have the same dimension.

Theorem 4.6.8. *Let $\mathcal{S} = \mathcal{S}_{\rho, \iota, \pi}$ be a Grassmannlike necklace with $\iota \leq_\circ \pi$. Let \mathcal{S}^* be the dual necklace with trip permutation $\mu = \rho^{-1}\iota$. Suppose that $\dim(\widetilde{\Pi}_\pi^\circ) = \dim(\widetilde{\Pi}_\mu^\circ)$. Then $\tilde{\tau}_\mathcal{S} : \widetilde{\Pi}_\pi^\circ \rightarrow \widetilde{\Pi}_\mu^\circ$ is an isomorphism of open positroid varieties with inverse $\tilde{\tau}_{\mathcal{S}^*} : \widetilde{\Pi}_\mu^\circ \rightarrow \widetilde{\Pi}_\pi^\circ$.*

One has similarly that $\tilde{\tau}_\mathcal{S} : \widetilde{\Pi}_\pi^\circ \rightarrow \widetilde{\Pi}_\mu^\circ$ is an isomorphism of open positroid varieties with inverse $\tilde{\tau}_{\mathcal{S}^*} : \widetilde{\Pi}_\mu^\circ \rightarrow \widetilde{\Pi}_\pi^\circ$.

Proof. Let $f, m, i \in \text{Bound}(k, n)$ be the bounded affine permutations corresponding to π, μ and ι , respectively, and set $r := f^{-1}i$. Our assumptions are that $f = ir^{-1}$ is length-additive and $\ell(m) = \ell(f)$. By Lemma 4.5.17, $m = i^{-1}fi = r^{-1}i$. The assumption that $\ell(m) = \ell(f)$ implies that $m = r^{-1}i$ is length-additive.

We would like to apply Proposition 4.6.7, so first we need to show that \mathcal{I}^* is a unit necklace in $\tilde{\Pi}_\mu^\circ$. We will do this by finding an appropriate rotation of \mathcal{I}^* .

Recall that since $i \in \text{Bound}(k, n)$, $i = e_k \tilde{i}$ for some $\tilde{i} \in \tilde{S}_n^0$. Note also that $r^{-1} \in \tilde{S}_n^0$, so $r^{-1}e_k \in \tilde{S}_n^k$. The factorization $m = (r^{-1}e_k)\tilde{i}$ is clearly also length-additive, so $r^{-1}e_k \leq_R m$ by definition. As $m \in \text{Bound}(k, n)$ and $(\text{Bound}(k, n), \leq_R)$ is a lower order ideal in (\tilde{S}_n^k, \leq_R) , we conclude that $r^{-1}e_k \in \text{Bound}(k, n)$. The associated permutation of type (k, n) is $r^{-1}e_k = \rho^{-1} \circ \epsilon_k$, and we have $\rho^{-1} \circ \epsilon_k \leq_\circ \mu$. So the Grassmannlike necklace $\mathcal{L} = (L_1, \dots, L_n)$ with insertion permutation $\rho^{-1} \circ \epsilon_k$ and trip permutation μ is a unit necklace in $\tilde{\Pi}_\mu^\circ$. But \mathcal{L} is just a rotation of \mathcal{I}^* : we have $\mathcal{I}^* = (L_{n-k+1}, \dots, L_n, L_1, \dots, L_{n-k})$. So \mathcal{I}^* is a unit necklace in $\tilde{\Pi}_\mu^\circ$, and also fulfills the hypotheses of Proposition 4.6.7.

The statements now follow immediately from applying Proposition 4.6.7 to the pair of necklaces $\mathcal{I}, \mathcal{I}^*$ and to $\mathcal{I}^*, (\mathcal{I}^*)^* = \mathcal{I}$. □

Example 4.6.9. Consider the intermediate necklace \mathcal{I}_1 from Example 4.5.6. This is the set of boundary target labels for the relabeled plabic graph G^ρ in the top center of Figure 4.1. The underlying plabic graph G has trip permutation $\mu = 564123$. Since \mathcal{I}_1 is weakly separated, the two positroid varieties $\tilde{\Pi}_\pi^\circ$ and $\tilde{\Pi}_\mu^\circ$ are isomorphic via the right twist along \mathcal{I}_1 .

By Oh's theorem, a matrix $[M_1, \dots, M_6]$ gives a point in $\tilde{\Pi}_\mu^\circ$ if the columns M_3 and M_4 are parallel and that the necklace variables $\tilde{\mathcal{I}}_\mu$ (i.e. the boundary labels of the left graph) are non-vanishing.

On the other hand, the defining conditions for membership in $\tilde{\Pi}_\pi^\circ$ are that Δ_{345} and Δ_{156} vanish, but the necklace variables (4.5.1) (or equivalently, any of the necklaces from Example 4.5.6) are non-vanishing.

The isomorphism $\tilde{\Pi}_\pi^\circ \cong \tilde{\Pi}_\mu^\circ$ is not implied by any obvious dihedral symmetries. It is also not apparent at the level of matroids: \mathcal{M}_π has 18 bases, while \mathcal{M}_μ has 16.

Inverting boundary measurements

In this section, we use twist maps along necklaces to deduce that $\Sigma_{G^\rho}^T$ gives a cluster structure on $\tilde{\Pi}_\pi^\circ$.

The following observation is used several times in this section. Consider $f \in \text{Bound}(k, n)$ with $\bar{f} = \pi$. Consider $a < b \in \mathbb{Z}$ such that $\ell(t_{ab}f) < \ell(f)$, and let $a', b' \in [n]$ be their reductions mod n .

Lemma 4.6.10 ([37, Lemma 4.5]). *With f, π, a', b' as above, let G be a reduced plabic graph with trip permutation π and let $I \in \vec{\mathbb{F}}(G)$ be a target label. If $b' \in I$, then $a' \in I$ also.*

We can partially order $[n]$ according to whether the conclusion of Lemma 4.6.10 holds.

By Lemma 4.6.4, twist maps along necklaces involve column permutation, which introduce unwanted signs in Plücker coordinates. Our next lemma allows us to compensate for these signs in our constructions.

Lemma 4.6.11. *Let G^ρ be a relabeled plabic graph as in the statement of Theorem 4.5.24(2). Then there exists an involutive automorphism $\underline{\epsilon} \in \text{Aut}(\text{Gr}(k, n))$ with the property that for any $I \in \overrightarrow{\mathbb{F}}(G)$ and $y \in \text{Gr}(k, n)$ we have*

$$\Delta_{\rho(I)}(y) = \Delta_I(\rho(\underline{\epsilon}(y))). \quad (4.6.10)$$

The automorphism $\underline{\epsilon}$ rescales the columns of $k \times n$ matrix representatives by appropriately chosen signs. The argument is similar to [37, Proposition 7.14].

Proof. Let $f, m, i \in \text{Bound}(k, n)$ be the permutations associated to π, μ, ι and set $r = f^{-1}i$. From the assumption (2) we have $\ell(m) = \ell(r^{-1}i) = \ell(r^{-1}) + \ell(i)$.

Consider an infinite matrix z with k rows and with columns $(z_i)_{i \in \mathbb{Z}}$. Let r act on z by permuting columns, so $r(z)_i = z_{r(i)}$. Then

$$\Delta_I(r(z)) = \det(z_{r(i_1)}, \dots, z_{r(i_k)}) \quad (4.6.11)$$

$$= (-1)^{\#\{a < b \in I \times I : \ell(rt_{ab}) < \ell(r)\}} \Delta_{r(I)}(z) \quad (4.6.12)$$

$$= (-1)^{\#\{a < b \in I \times I : \ell(t_{ab}r^{-1}) < \ell(r^{-1})\}} \Delta_{r(I)}(z) \quad (4.6.13)$$

$$= (-1)^{\#\{a < b \in I \times [n] : \ell(t_{ab}r^{-1}) < \ell(r^{-1})\}} \Delta_{r(I)}(z) \quad (4.6.14)$$

$$= \prod_{a \in I} (-1)^{\#\{b \in [n] : \ell(rt_{ab}) < \ell(r)\}} \Delta_{r(I)}(z). \quad (4.6.15)$$

The second equality is sorting the columns; the third is the statement that inversion of affine permutations does not affect length. The fourth equality follows from Lemma 4.6.10 since

$$\ell(t_{ab}m) = \ell(t_{ab}r^{-1}i) \leq \ell(t_{ab}r^{-1}) + \ell(i) < \ell(m)$$

using length-additivity. The last line is immediate.

Now we specialize $z_i = y_{i \bmod n}$ and compare the sign relating $\Delta_{r(I)}(z)$ to $\Delta_{\rho(I)}(y)$. Write $r(I) = r_1 < r_2 < \dots < r_k$. If $r_a < 0$, then r_a must sort past $|r(I) \cap [1, r_a + n]|$ many values in order for it to occupy the correct place in $\rho(I)$. By the dual argument when $r_a > n$, we have:

$$\Delta_{r(I)}(z) = \prod_{a: r_a < 0} (-1)^{\#r(I) \cap [1, r_a + n]} \prod_{a: r_a > n} (-1)^{\#r(I) \cap (r_a - n, n]} \Delta_{\rho(I)}(y).$$

Let $(\delta : r_a < 0)$ denote 1 if $r_a < 0$ and zero otherwise and define similarly $(\delta : r_a > n)$. We define the sign

$$\epsilon_a = (-1)^{\#\{b \in [n] : \ell(rt_{ab}) < \ell(r)\} + (\delta : r_a < 0)(\#r(I) \cap [1, \rho_a]) + (\delta : r_a > n)\#r(I) \cap (\rho(a), n]}$$

and define an automorphism $\underline{\epsilon}' \in \text{Aut}(\text{Gr}(k, n))$ rescaling the a th column by the sign ϵ_a (for $a = 1, \dots, n$). Let $\underline{\epsilon} \in \text{Aut}(\text{Gr}(k, n))$ rescale the a th column by the sign $\epsilon_{\rho(a)}$ so that $\underline{\epsilon}' \circ \rho = \rho \circ \underline{\epsilon}$. Combining the two calculations above, we have $\Delta_{\rho(I)}(y) = \Delta_I(\underline{\epsilon}'\rho(y)) = \Delta_I(\rho\underline{\epsilon}(y))$ as desired. \square

We follow the notation in [37], denoting by $(\mathbb{C}^*)^E/(\mathbb{C}^*)^{V-1}$ the algebraic torus of edge weights on G^ρ modulo restricted gauge transformations at vertices, and by \mathbb{C}^F an algebraic torus whose coordinates are indexed by the faces of G^ρ . (Neither of these algebraic tori is sensitive to the relabeling of the boundary vertices.)

For a plabic graph G , there is a *boundary measurement map* $\tilde{\mathbb{D}}_G$ from $(\mathbb{C}^*)^E/(\mathbb{C}^*)^{V-1} \rightarrow \widetilde{\text{Gr}}(k, n)$. The I th Plücker coordinate of a point in the image is the weight-generating function for matchings of G with boundary I .

For a relabeled plabic graph G^ρ , we define $\tilde{\mathbb{D}}_{G^\rho} := \rho^{-1} \circ \tilde{\mathbb{D}}_G$. Up to sign, $\tilde{\mathbb{D}}_{G^\rho}$ is the weight-generating function for matchings of G^ρ with given boundary (taking into account the relabeling of vertices according to ρ).

We also have a rational map $\vec{\mathbb{F}}_{G^\rho}(\bullet): \widetilde{\text{Gr}}(k, n) \rightarrow (\mathbb{C}^*)^F$ given by evaluating the Plücker coordinates $\Delta(\vec{\mathbb{F}}(G^\rho))$. This evaluation map agrees with the composition $\vec{\mathbb{F}}_G(\bullet) \circ \rho$ up to sign. More specifically, by Lemma 4.6.11 we have $\vec{\mathbb{F}}_{G^\rho}(\bullet) = \vec{\mathbb{F}}_G(\bullet) \circ \rho \circ \underline{\epsilon}$.

Muller and Speyer defined an invertible Laurent monomial map $\vec{\partial}: (\mathbb{C}^*)^F \rightarrow (\mathbb{C}^*)^E/(\mathbb{C}^*)^{V-1}$ whose inverse is denoted $\vec{\mathbb{M}}$. We do not use any properties of either $\vec{\partial}$ or $\vec{\mathbb{M}}$ beyond that they fit into the commutative diagram [37, Theorem 7.1] and are monomial maps.

Proposition 4.6.12. *Suppose G^ρ is a relabeled plabic graph with trip permutation π satisfying Theorem 4.5.24(1) and let μ be the trip permutation of the underlying graph G . Then we have a commutative diagram*

$$\begin{array}{ccc}
 (\mathbb{C}^*)^F & \xrightarrow{\vec{\partial}} & (\mathbb{C}^*)^E/(\mathbb{C}^*)^{V-1} \\
 \vec{\mathbb{F}}_{G^\rho}(\bullet) \uparrow \vdots & & \downarrow \tilde{\mathbb{D}}_{G^\rho} \\
 \tilde{\Pi}_\pi^\circ & \xleftarrow[\underline{\epsilon \circ \bar{\tau}_\pi}]{} & \rho^{-1}(\tilde{\Pi}_\mu^\circ)
 \end{array} \quad . \quad (4.6.16)$$

In particular the domain of definition of $\vec{\mathbb{F}}_{G^\rho}(\bullet)$ is an algebraic torus and $\Delta(\vec{\mathbb{F}}_{G^\rho}) \subset \mathbb{C}(\tilde{\Pi}_\pi^\circ)$ is a seed.

Before the proof of Proposition 4.6.12, we mention a corollary related to total positivity. Recall that $\tilde{\Pi}_{\pi, >0}^\circ = \{x \in \tilde{\Pi}_\pi^\circ : \Delta_I(x) > 0 \text{ for all } I \in \mathcal{M}_\pi\}$.

Corollary 4.6.13. *Suppose $\iota \leq_\circ \pi$ are permutations of type (k, n) and the Grassmannlike necklace $\mathcal{S} = \mathcal{S}_{\rho, \iota, \pi}$ is weakly separated. Let $\mu := \rho^{-1}\iota$. Then $\vec{\tau}_\mathcal{S} \circ \underline{\epsilon}(\tilde{\Pi}_{\pi, >0}^\circ) = \tilde{\Pi}_{\mu, >0}^\circ$.*

Proof. By Proposition 4.6.12, the map $\vec{\tau}_\mathcal{S} \circ \underline{\epsilon}: \tilde{\Pi}_\pi^\circ \rightarrow \tilde{\Pi}_\mu^\circ$ can also be expressed as a composition $\tilde{\mathbb{D}}_G \circ \vec{\partial} \circ \vec{\mathbb{F}}_{G^\rho}$. Each of the maps in the composition sends $\mathbb{R}_{>0}$ -points to $\mathbb{R}_{>0}$ -points and is surjective on such points. \square

Proof of Proposition 4.6.12. From the commutativity of the left square in [37, Theorem 7.1], we have

$$\vec{\mathbb{M}} = \vec{\mathbb{F}}_G(\bullet) \circ \vec{\tau}_\mu \circ \tilde{\mathbb{D}}_G \quad (4.6.17)$$

as maps $(\mathbb{C}^*)^E/(\mathbb{C}^*)^{V-1} \rightarrow (\mathbb{C}^*)^F$.

We seek to prove the commutativity:

$$\tilde{M} = \vec{\mathbb{F}}_{G^\rho}(\bullet) \circ \underline{\epsilon} \circ \tilde{\tau}_\pi \circ \tilde{D}_{G^\rho} = \vec{\mathbb{F}}_G(\bullet) \circ \rho \circ \tilde{\tau}_\pi \circ \rho^{-1} \circ \tilde{D}_G. \quad (4.6.18)$$

Since \tilde{D}_G is invertible, it suffices to prove that

$$\vec{\mathbb{F}}_G(\bullet) \circ \tilde{\tau}_\mu = \vec{\mathbb{F}}_G(\bullet) \circ \rho \circ \tilde{\tau}_\pi \circ \rho^{-1} \quad (4.6.19)$$

as maps $\tilde{\Pi}_\mu^\circ \rightarrow (\mathbb{C}^*)^F$. Let F be a face of G and $y \in \tilde{\Pi}_\mu^\circ$. Set $x' = \tilde{\tau}_\mu(y)$ and $x = \rho \tilde{\tau}_\pi \rho^{-1}(y)$. By Theorem 4.6.8 we have $\tilde{\tau}_\mu \tilde{\tau}_\mu(x) = x'$. So to establish (4.6.19) we need to prove that if $I = \vec{I}(F)$ is a target label of a plabic graph with trip permutation μ and if $x \in D(\vec{I})$, then $\Delta_I(x) = \Delta_I(\tilde{\tau}_\mu \tilde{\tau}_\mu(x))$. We prove this in Lemma 4.6.14 below. The commutativity of (4.6.16) is proved.

By the commutativity of the diagram, the domain of definition of $\vec{\mathbb{F}}_{G^\rho}(\bullet)$ is the image of $\tilde{\tau}_\pi \tilde{D}_{G^\rho} = \tilde{\tau}_{\mathcal{J}^*} \circ \tilde{D}_G$. Thus, it is an algebraic torus because $\tilde{\tau}_{\mathcal{J}^*}$ is an isomorphism by Theorem 4.6.8. Any regular function on $\tilde{\Pi}^\circ$ restricts to a regular function on this algebraic torus, hence to a Laurent polynomial in its basis of characters $\Delta(\vec{\mathbb{F}}_{G^\rho})$. This shows that every regular function can be expressed as Laurent polynomial in $\Delta(\vec{\mathbb{F}}_{G^\rho})$. Thus, $\Delta(\vec{\mathbb{F}}_{G^\rho})$ generates the function field $\mathbb{C}(\tilde{\Pi}_\pi^\circ)$. Since $\dim \tilde{\Pi}_\pi^\circ = \#\vec{\mathbb{F}}_{G^\rho}$ we conclude that $\Delta(\vec{\mathbb{F}}_{G^\rho})$ is algebraically independent and thus $\Sigma_{G^\rho}^T$ is a seed in $\mathbb{C}(\tilde{\Pi}_\pi^\circ)$. \square

Lemma 4.6.14. *If $I = \vec{I}(F)$ is the target label of a reduced plabic graph with trip permutation π , and if $z \in D(\vec{I}_\pi)$, then $\Delta_I(z) = \Delta_I(\tilde{\tau}_\pi \tilde{\tau}_\pi(z))$.*

Proof. Since we always deal with $\tilde{\tau}_\pi$ and $\tilde{\tau}_\pi$ in this proof, we omit the subscript π .

As discussed above, the conclusion of Lemma 4.6.10 endows $[n]$ with a partial order which we will denote by $<$ during this proof. That is, if $a < b$, then b appears in the target label I of a plabic graph whenever a does.

Let M be a matrix with columns M_1, \dots, M_n , representing a point $z \in D(\vec{I}_\pi)$. We claim that for any $b \in [n]$, we have

$$(\tilde{\tau} \tilde{\tau}(M))_{\pi(a)} \in \text{span}\{M_{\pi(b)}: \pi(a) < \pi(b)\}. \quad (4.6.20)$$

By Lemma 4.6.10, since $\pi(a) \in \vec{I}_{\pi(a)}$, we have $\{\pi(b): \pi(a) < \pi(b)\} \subset \vec{I}_{\pi(a)}$. Therefore, since $z \in D(\vec{I}_\pi)$, the column vectors on the right hand side of (4.6.20) are linearly independent. By the definition of $\tilde{\tau}$ we have $\langle (\tilde{\tau} \tilde{\tau}(M))_{\pi(a)}, \tilde{\tau}(M)_{\pi(a)} \rangle = 1$. Assuming (4.6.20), and using the definition of $\tilde{\tau}$, it would follow that the coefficient of $M_{\pi(a)}$ in $(\tilde{\tau} \tilde{\tau}(M))_{\pi(a)}$ is 1. Choosing an ordering of columns that refines the partial order $<$, the matrices $(M_a)_{a \in \vec{I}(F)}$ and $((\tilde{\tau} \tilde{\tau} M)_a)_{a \in \vec{I}(F)}$ are then related by a triangular matrix with ones on the diagonal,

hence the two matrices have the same determinant. This is the desired equality of Plücker coordinates $\Delta_I(z) = \Delta_I(\tilde{\tau}_\pi \vec{\tau}_\pi(z))$.

So it remains to establish (4.6.20). We have

$$(\tilde{\tau} \vec{\tau}(M))_{\pi(a)} \in \left(\text{span}(\vec{\tau}(M)_x)_{x \in \vec{I}_{\pi(a)} \setminus \pi(a)} \right)^\perp \subseteq \bigcap_{x \in \vec{I}_{\pi(a)} \setminus \pi(a)} \text{span}(M_y)_{y \in \vec{I}_x \setminus x} \quad (4.6.21)$$

$$\subseteq \bigcap_{x \in \vec{I}_{\pi(a)} \cap (a, \pi(a))} \text{span}(M_y)_{y \in \vec{I}_x \setminus x}. \quad (4.6.22)$$

We list those x appearing in (4.6.22) from left to right so that $a < x_s < \dots < x_1 < \pi(a)$ in cyclic order. Let w be in the cyclic interval $(a, \pi(a))$. It follows by comparing the definitions of $\vec{I}_{\pi(a)}$ and \vec{I}_w that

$$\pi(w) \in (w, \pi(a)) \text{ if and only if } w \notin \{x_1, \dots, x_s\}. \quad (4.6.23)$$

We claim inductively that

$$\bigcap_{j=1}^t \text{span}(M_y)_{y \in \vec{I}_{x_j} \setminus x_j} = \text{span}(M_y)_{y \in \vec{I}_{\pi(a)} \setminus \{\pi(x_1), \dots, \pi(x_t)\}}.$$

When $t = 0$ we interpret the left hand side as an empty intersection (hence, as all of \mathbb{C}^k) and the base case holds since $M \in D(\vec{I})$. Evaluating the inductive claim when $t = s$ and using (4.6.23) we see that the right hand side is spanned by $M_{\pi(a)}$ as well as various $M_{\pi(b)}$'s where $b < a < \pi(a) < \pi(b)$ which is the claim (4.6.20).

Assuming the claim for a given $t \in [0, s)$, we have

$$\begin{aligned} \bigcap_{j=1}^{t+1} \text{span}(M_y: y \in \vec{I}_{x_j} \setminus x_j) &= \text{span}(M_y)_{y \in \vec{I}_{x_{t+1}} \setminus x_{t+1}} \cap \text{span}(M_y)_{y \in \vec{I}_{\pi(a)} \setminus \{\pi(x_1), \dots, \pi(x_t)\}} \\ &= \text{span}(M_y: y \in \vec{I}_{\pi(a)} \setminus \{\pi(x_1), \dots, \pi(x_t)\} \cap \vec{I}_{x_{t+1}} \setminus x_{t+1}) \\ &= \text{span}(M_y)_{y \in \vec{I}_{\pi(a)} \setminus \{\pi(x_1), \dots, \pi(x_{t+1})\}}. \end{aligned}$$

The first equality is the inductive assumption. To establish the second equality, we claim that $(\vec{I}_{x_{t+1}} \setminus x_{t+1}) \cup (\vec{I}_{\pi(a)} \setminus \{\pi(x_1), \dots, \pi(x_t)\}) \subseteq \vec{I}_{x_{t+1}+1}$. The first containment is the definition of Grassmann necklace and the second containment follows from (4.6.23). Since $M \in D(\vec{I})$, the vectors $\{M_y: y \in \vec{I}_{x_{t+1}+1}\}$ are independent. Thus, we can replace the intersection of spans with the span of the intersections, justifying the second line. Passing from the second line to the third again follows from (4.6.23), noting that $\pi(x_{t+1}) \in \vec{I}_{\pi(a)}$ but is not in \vec{I}_{x_t} . This completes the inductive proof, establishing (4.6.20). \square

Theorem 4.6.15. *Suppose $\pi \rho \leq_o \pi$ and let G^ρ be a reduced plabic graph with trip permutation π . Suppose G^ρ satisfies Theorem 4.5.24(1). Then we have the equality of cluster algebras $\mathcal{A}(\Sigma_{G^\rho}^T) = \mathbb{C}[\tilde{\Pi}_\pi^o]$.*

Proof. First we claim that the analogue of the double twist formula [37, Proposition 7.13] holds. Let $\varphi := \vec{\tau}_\mu \circ \vec{\tau}_{\mathcal{J}} \circ \underline{\varepsilon} = \vec{\tau}_\mu^2 \circ \rho \circ \underline{\varepsilon} : \widetilde{\Pi}_\pi^\circ \rightarrow \widetilde{\Pi}_\mu^\circ$. We claim that $\varphi^*(\Sigma_G^S) \sim \Sigma_{G^\rho}^T$, i.e. that the seed obtained by pulling back the source collection $\Sigma_G^S \subset \mathbb{C}[\widetilde{\Pi}_\mu^\circ]$ along φ is quasi-equivalent to the target seed $\Sigma_{G^\rho}^T$. Indeed, we can rewrite our commutative diagram (4.6.16) and combine it with the right diagram in [37, Theorem 7.1] to obtain a commutative diagram

$$\begin{array}{ccccc}
 (\mathbb{C}^*)^F & \xrightarrow{\vec{\delta}} & (\mathbb{C}^*)^E / (\mathbb{C}^*)^{V-1} & \xrightarrow{\vec{M}} & (\mathbb{C}^*)^F \\
 \uparrow \vec{\mathbb{F}}(G^\rho)(\bullet) & & \downarrow \vec{\mathbb{D}}_G & & \uparrow \vec{\mathbb{F}}(G) \\
 \widetilde{\Pi}_\pi^\circ & \xrightarrow{\vec{\tau}_{\mathcal{J}} \circ \underline{\varepsilon}} & \widetilde{\Pi}_\mu^\circ & \xrightarrow{\vec{\tau}_\mu} & \widetilde{\Pi}_\mu^\circ
 \end{array} \tag{4.6.24}$$

Repeating the proof of [37, Proposition 7.13] using this diagram we obtain the formula

$$\Delta_{\vec{I}(F)}^{\leftarrow \bullet}(\varphi(y)) = \Delta_{\rho(\vec{I}(F))}^{\rightarrow \bullet}(y) \prod_{i \in \vec{I}(F)} \frac{\Delta_{I_i}(y)}{\Delta_{I_{i+1}}(y)}. \tag{4.6.25}$$

The Plücker coordinate on the left is in $\vec{\mathbb{F}}(G)$ whereas the Plücker coordinate $\rho(\vec{I}(F)) \in \vec{\mathbb{F}}(G^\rho)$ and likewise for the necklace variables $I_i, I_{i+1} \in \mathcal{J}$. Since \mathcal{J} is a unit necklace, the multiplicative factor on the right hand side of (4.6.25) is in \mathbb{P}_π as required by Definition 4.3.15. To complete the proof that $\varphi^*(\Sigma_G^S) \sim \Sigma_{G^\rho}^T$, we need to check that the \hat{y} 's in these two seeds coincide. That is, we need to show that the multiplicative \mathbb{P}_π -factors on the right hand side of (4.6.25) cancel out when we compute the Laurent monomial \hat{y} . This follows from the well-known fact that each of the \hat{y} monomials is homogeneous with respect to the \mathbb{Z}^n -grading on $\mathbb{C}[\widetilde{\Pi}_\pi^\circ]$ given by the degree in the column vectors: the number of times that a given i appears in the numerator of each \hat{y} cancels with the number of times it appears in the denominator, and thus the same is true of each $\Delta_{I_i}/\Delta_{I_{i+1}}$.

Since $\varphi^*(\Sigma_G^S) \sim \Sigma_{G^\rho}^T$, we have then that

$$\mathcal{A}(\Sigma_{G^\rho}^T) = \mathcal{A}(\varphi^*(\Sigma_G^S)) = \varphi^*(\mathcal{A}(\Sigma_G^S)) = \varphi^*(\mathbb{C}[\widetilde{\Pi}_\mu^\circ]) = \mathbb{C}[\widetilde{\Pi}_\pi^\circ].$$

□

This completes the proof of Theorem 4.5.24. We also have the following corollary about the positive parts of $\widetilde{\Pi}_\pi^\circ$ determined by seeds from relabeled plabic graphs.

Corollary 4.6.16. *Suppose $\pi\rho \leq_\circ \pi$. Suppose G^ρ is a relabeled plabic graph with trip permutation π and satisfies Theorem 4.5.24(1). Then the positive part of $\widetilde{\Pi}_\pi^\circ$ determined by $\Sigma_{G^\rho}^T$ is equal to $\widetilde{\Pi}_{\pi, > 0}^\circ$. That is,*

$$\{x \in \widetilde{\Pi}_\pi^\circ : \Delta_{\vec{I}(F)}^{\rightarrow \bullet}(x) > 0 \text{ for all faces } F \text{ of } G^\rho\} = \{x \in \widetilde{\Pi}_\pi^\circ : \Delta_I(x) > 0 \text{ for all } I \in \mathcal{M}_\pi\}.$$

Proof. Let $\mathcal{J} = \mathcal{J}_{\rho, \iota, \pi}$. It is weakly separated. Let $\mu := \rho^{-1}\iota$.

Notice that one of the containments is obvious, since by Proposition 4.6.12, the target face labels of G^ρ are in \mathcal{M}_π .

The other containment follows from Corollary 4.6.13 and its dual statement, which is that $\underline{\epsilon} \circ \tilde{\tau}_{\mathcal{J}^*}(\tilde{\Pi}_{\mu, >0}^\circ) = \tilde{\Pi}_{\pi, >0}^\circ$. Indeed, suppose that for some $x \in \tilde{\Pi}^\circ$, all Plücker coordinates in $\vec{\mathbb{F}}(G^\rho)$ are positive. By Corollary 4.6.13, $\tilde{\tau}_{\mathcal{J}} \circ \underline{\epsilon}(x) \in \tilde{\Pi}_{\mu, >0}^\circ$. From the dual statement, we have that

$$\underline{\epsilon} \circ \tilde{\tau}_{\mathcal{J}^*}(\tilde{\tau}_{\mathcal{J}} \circ \underline{\epsilon}(x)) = x \in \tilde{\Pi}_{\pi, >0}^\circ.$$

□

4.7 Quasi-equivalence and cluster structures from relabeled plabic graphs

In this section, we investigate the relationship between the different cluster structures on $\tilde{\Pi}_\pi^\circ$ given by Theorem 4.5.24, and verify Conjecture 4.1.1 for a class of positroids we call “toggle-connected.”

First we restate a conjecture from the introduction:

Conjecture 4.7.1. *Let G^ρ be a relabeled plabic graph satisfying the conditions of Theorem 4.5.24, determining a cluster structure on $\tilde{\Pi}_\pi^\circ$. Let H be a plabic graph with trip permutation π . Then the seeds $\Sigma_{G^\rho}^T$ and Σ_H^T are related by a quasi-cluster transformation, i.e. the cluster structures $\mathcal{A}(\Sigma_{G^\rho}^T)$ and $\mathcal{A}(\Sigma_H^T)$ are quasi-equivalent.⁹*

Remark 4.7.2. In Example 4.4.3 we explained that $\Sigma_G^S = \Sigma_{G^{\pi^{-1}}}^T$. This however does not fit into the framework of Theorem 4.5.24 and Conjecture 4.7.1 because when $\rho = \pi^{-1}$, $\iota := \pi\rho$ does not have type (k, n) . We now explain how this can be fixed via appropriate cyclic shifts.

Let G be a graph with trip permutation π . The relabeled graph $H := G^{\epsilon_k^{-1}}$ has trip permutation $i - k \mapsto \pi(i) - k$. Setting $\rho := \pi^{-1}\epsilon_k$ we have that $\iota = \epsilon_k$ has type (k, n) . The corresponding μ is $\epsilon_k^{-1}\pi\epsilon_k$ mapping $i \mapsto \pi(i + k) - k$. Thus, μ is the trip permutation of the relabeled graph H .

By Example 4.4.3 we have $\Sigma_G^S = \Sigma_{G^{\pi^{-1}}}^T = \Sigma_{H^\rho}^T$. That is, the source-labeled seed of G is of the form $\Sigma_{H^\rho}^T$ for an appropriate H with trip permutation μ and ρ of type (k, n) , as required in Theorems 4.5.14 and 4.5.24.

Remark 4.7.3. If Conjecture 4.7.1 holds, then the positive part of $\tilde{\Pi}_\pi^\circ$ determined by $\Sigma_{G^\rho}^T$ would agree with the positive part determined by Σ_H^T . And, indeed, Corollary 4.6.16 shows that all of these positive parts are the same, supporting Conjecture 4.7.1.

We have the following result in the direction of Conjecture 4.7.1.

⁹In the language of [17], this conjecture says that the map $\tilde{\tau}_{\mathcal{J}} \circ \underline{\epsilon}$ from Section 4.6 is a *quasi-isomorphism* of the target structures on $\tilde{\Pi}_\pi^\circ$ and $\tilde{\Pi}_\mu^\circ$.

Theorem 4.7.4. *Suppose $\pi\rho \leq_o \pi$ and $\pi\sigma \leq_o \pi$. Let G^ρ and H^σ be relabeled plabic graphs with trip permutation π satisfying Theorem 4.5.24(1) and let $\mathcal{S}_1 = \mathcal{S}_{\rho, \bullet, \pi}$ and $\mathcal{S}_2 = \mathcal{S}_{\sigma, \bullet, \pi}$ be the Grassmannlike necklaces corresponding to their boundary faces.*

If \mathcal{S}_1 and \mathcal{S}_2 are related by an aligned toggle at some position, then the cluster algebras $\mathcal{A}(\Sigma_{G^\rho}^T)$ and $\mathcal{A}(\Sigma_{H^\sigma}^T)$ are quasi-equivalent.

The proof of Theorem 4.7.4 is in Section 4.8. Informally, the argument is that one can find an appropriate relabeled plabic graph G^ρ with trip permutation π so that the aligned toggle relating \mathcal{S}_1 and \mathcal{S}_2 can be realized as “performing a square move” at a boundary face of G^ρ . This operation is a quasi-cluster transformation. We make this precise using the plabic tilings of [39].

The following graph summarizes the quasi-equivalences which follow from Theorem 4.7.4.

Definition 4.7.5. Fix $f \in \text{Bound}(k, n)$ and let Sep_f be the set of $i \leq_R f$ such that $\ell(i^{-1}fi) = \ell(f)$. Define an (undirected) graph TG_f on Sep_f by putting an edge between i and w if $w = is_a$ for some a . That is, TG_f is obtained from the Hasse diagram of the lower order ideal of f in $(\text{Bound}(k, n), \leq_R)$ by deleting all elements $i \leq_R f$ with $\ell(i^{-1}fi) \neq \ell(f)$ (see Figure 4.2).

If $i, w \in J_f$ are in the same connected component of TG_f , we write $i \sim_f w$. We say that f is *toggle-connected* if $f \sim_f e_k$.

We define an analogous graph for permutations of type (k, n) by applying the map $f \mapsto \bar{f}$ everywhere, and use the same notation.

Remark 4.7.6. Each vertex of TG_f corresponds to a Grassmannlike necklace satisfying condition (2) of Theorem 4.5.24, thus to a cluster structure on $\tilde{\Pi}_\pi$. The edges of TG_f record when two such necklaces are related by an aligned toggle. By Theorem 4.7.4, any two necklaces in the same connected component of TG_f determine quasi-equivalent cluster structures.

Example 4.7.7. Continuing Examples 4.5.6 and 4.5.20, we have that Sep_f agrees with the lower order ideal of f in $(\text{Bound}(3, 6), \leq_R)$; it consists of permutations $f = [4, 6, 5, 8, 7, 9]$, $[4, 5, 6, 8, 7, 9]$, $[4, 6, 5, 7, 8, 9]$, and e_3 . In this case, TG_f is the Hasse diagram of this lower order ideal, i.e. TG_f is a 4-cycle. In particular, f is toggle-connected.

By Theorem 4.7.4, all four of the seeds $\Sigma_{G^\rho}^T$ from Figure 4.1 give rise to quasi-equivalent cluster structures. Each of these cluster structures has finite Dynkin type A_2 .

For the leftmost graph, i.e. for the target structure, three of the five clusters come from plabic graphs. The five cluster variables are

$$\Delta_{124}, \Delta_{246}, \Delta_{236}, \Delta_{356}, \Delta_{346}\Delta_{125}, \tag{4.7.1}$$

listed so that adjacent cluster variables form a cluster. The last cluster variable in (4.7.1) is a product of two Plücker coordinates hence is not the target label of a plabic graph.

The same goes for the rightmost graph, i.e. for the source labeling, with cluster variables $\Delta_{236}, \Delta_{246}, \Delta_{124}, \Delta_{145}$, and $\Delta_{146}\Delta_{235}$.

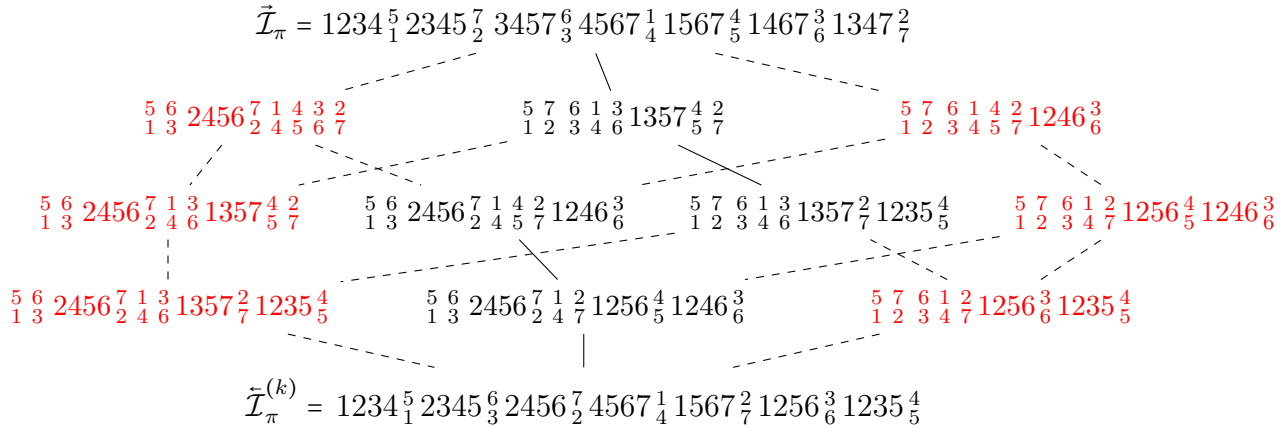

Figure 4.2: The \leq_\circ lower order ideal of $\pi = 5761432$, a permutation of type $(4, 7)$. For each $\iota \leq_\circ \pi$, the Grassmannlike unit necklaces $\mathcal{S}_{\bullet, \iota, \pi}$ is displayed (to save space, elements of $\tilde{\mathcal{L}}_\pi$ are omitted from intermediate necklaces). The weakly separated necklaces, which have insertion permutation $\iota \in \text{Sep}_\pi$, are in black. For example, any necklace containing $2456, 1347$ is not weakly separated. Edges are cover relations in \leq_\circ : solid edges are edges in TG_π , while dashed edges are not. Since there is no solid path from the top to the bottom, π is not toggle-connected.

For the two intermediate cluster structures, every cluster comes from a relabeled plabic graph and every cluster variable is a Plücker coordinate. The cluster variables for the top center graph are $\Delta_{124}, \Delta_{246}, \Delta_{236}, \Delta_{235}$, and Δ_{125} . Those for the bottom center graph are $\Delta_{124}, \Delta_{246}, \Delta_{236}, \Delta_{136}$, and Δ_{134} .

We see that the Plücker coordinates

$$\Delta_{123}, \Delta_{234}, \Delta_{346}, \Delta_{456}, \Delta_{256}, \Delta_{126}, \Delta_{146}, \Delta_{245} \in \mathbb{P}_\pi,$$

while the Plücker coordinates

$$\Delta_{124}, \Delta_{246}, \Delta_{236}, \Delta_{356} \equiv \Delta_{136} \equiv \Delta_{235}, \Delta_{134} \equiv \Delta_{125} \equiv \Delta_{145}$$

are cluster variables (or a cluster variable times an element of \mathbb{P}_π) in each of the 4 cluster structures. We use \equiv to denote equality up to multiplication by an element of \mathbb{P}_π . One can check that $\Delta_{135} = \frac{\Delta_{356}\Delta_{125}}{\Delta_{256}}$ is a nontrivial cluster monomial. This accounts for 18 Plücker coordinates, and the remaining two are $345, 156 \notin \mathcal{M}_\pi$.

Combining Remark 4.7.2 with Remark 4.7.6, we have the following.

Corollary 4.7.8. *If π is toggle-connected, then the source and target cluster structures on $\tilde{\Pi}_\pi^\circ$ are quasi-equivalent.*

Remark 4.7.9. It is an unfortunate fact of life that not every $\pi \in \text{Bound}(k, n)$ is toggle-connected. We do not see a way of constructing a quasi-cluster transformation from the target structure to the source structure purely within the world of Plücker coordinates and square moves. On the other hand, our results break up this problem into smaller subproblems (namely, the subproblem of finding a sequence of quasi-cluster transformations between connected components of TG_π).

We end this section by investigating TG_π for open Schubert and opposite Schubert varieties, and showing that Conjecture 4.7.1 holds for these classes.

Definition 4.7.10. A (loopless) open positroid variety $\widetilde{\Pi}_\pi^\circ \subseteq \widetilde{\text{Gr}}(k, n)$ is an *open Schubert variety* if π has a single descent and no fixed points before the descent. It is an *open opposite Schubert variety* if the numbers $1, \dots, k$ and $k + 1, \dots, n$ appear in increasing order in π and none of $k + 1, \dots, n$ are fixed points.¹⁰

Proposition 4.7.11. *Let $\widetilde{\Pi}_\pi^\circ$ be an open Schubert or opposite Schubert variety. Then for all $\iota \leq_\circ \pi$, $\iota \in \text{Sep}_\pi$.*

Proof. First, suppose $\widetilde{\Pi}_\pi^\circ \subseteq \widetilde{\text{Gr}}(k, n)$ is an open Schubert variety, so π has a single descent. That is, there is a single a such that $\pi(a) > \pi(a + 1)$. Since π has no fixed points in $[a]$, all of $\pi(1), \dots, \pi(a)$ are not anti-excedences of π . On the other hand, all of $\pi(a + 1), \dots, \pi(n)$ are anti-excedences of π , so $a = n - k$.

The bounded affine permutation f corresponding to π satisfies $f(b) = \pi(b)$ for $b \in [n - k]$ and $f(b) = \pi(b) + n$ for $b = n - k + 1, \dots, n$. If $a < b$ and $f(a) > f(b)$ with $a \in [n]$, then $b > n$, since the window notation of f consists of an increasing sequence. Additionally, we have $f(a), f(b) \in [n + 1, 2n]$. This means that the right associated reflections of f all have the form t_{ab} where $a \in [n]$ and $b > n$ and the left associated reflections of f all have the form t_{ab} where $a, b \in [n]$. Thus, $T_L(f) \cap T_R(f) = \emptyset$.

Now, consider any $i \leq_R f$, so $f = iw$ is length-additive. By Lemma 4.3.25, $T_L(i) \subseteq T_L(f)$ and $T_R(w) \subseteq T_R(f)$, so in particular, $T_L(i) \cap T_R(w)$ is empty. By Lemma 4.3.24, this means that wi is length-additive. Since $i^{-1}fi = wi$, we have that $\ell(i^{-1}fi) = \ell(w) + \ell(i) = \ell(f)$, so $i \in \text{Sep}_f$. This implies that $\iota := \bar{i}$ is in Sep_π . Since the choice of i was arbitrary, this completes the proof.

The proof for opposite Schubert varieties is similar. □

As an immediate corollary, we obtain the following.

Theorem 4.7.12. *Let $\widetilde{\Pi}_\pi^\circ$ be an open Schubert or opposite Schubert variety. Then each relabeled plabic graph G^ρ with trip permutation π whose boundary satisfies $\pi\rho \leq_\circ \pi$ gives rise to a cluster structure on $\widetilde{\Pi}^\circ$. Moreover, all of these cluster structures are quasi-equivalent.*

In particular, Conjecture 4.1.1 holds for $\widetilde{\Pi}_\pi^\circ$.

¹⁰Open Schubert varieties correspond to Le-diagrams that are filled entirely with pluses. Open opposite Schubert varieties correspond to Le-diagrams whose shape is a $k \times (n - k)$ rectangle and whose zeros form a partition.

Remark 4.7.13. Open skew-Schubert varieties are another class of positroid variety, indexed by skew-shapes contained in a rectangle. Relabeled plabic graphs with a particular boundary were shown to give a cluster structure on open skew-Schubert varieties in [47]. In fact, it is not difficult to show that open skew-Schubert varieties are toggle-connected, and moreover that the cluster structure given in [47] are quasi-equivalent to the target and source cluster structures.

4.8 Proofs

We prove Theorems 4.5.19 and 4.7.4, as well as various subsidiary lemmas mentioned in the text.

Proof of Lemma 4.5.7

Recall the definition of noncrossing and aligned chords and toggles from Definition 4.5.5.

By Remark 4.5.9, if we perform an aligned toggle at a necklace \mathcal{S} satisfying $\mathcal{S} \subset \mathcal{M}_\pi$ then the new necklace $\mathcal{S}' \subset \mathcal{M}_\pi$ as well.

Since ρ and ι determine \mathcal{S} , we will frequently omit the subsets I_i , writing the removal and insertion values in the following *two-line notation*:

$$\mathcal{S} = \begin{array}{c} \iota_1 \ \iota_2 \ \dots \ \iota_{n-1} \ \iota_n \\ \rho_1 \rho_2 \ \dots \ \rho_{n-1} \ \rho_n \end{array}. \tag{4.8.1}$$

Now we prove Lemma 4.5.7 which is needed in the proof of Theorem 4.5.14.

Proof of Lemma 4.5.7. Let $\vec{\mathcal{I}}_\pi$ be a forward Grassmann necklace. Suppose $\mathcal{S} = (I_1, \dots, I_n)$ is a Grassmannlike necklace which can be obtained $\vec{\mathcal{I}}_\pi$ by a sequence of noncrossing toggles.

We prove the following more specific claim which readily implies the desired statement. We abbreviate $L = I_{\rho^{-1}(a)}$ and $R = I_{\rho^{-1}(a)+1}$.

Claim: There exist sets $\mathcal{S}, \mathcal{T} \subset [n] \setminus \{\pi(a), a\}$, with

$$L = \vec{I}_a \setminus (\pi^{-1}\mathcal{T} \cup \mathcal{S}) \coprod (\mathcal{T} \cup \pi^{-1}\mathcal{S}) \tag{4.8.2}$$

$$R = \vec{I}_{a+1} \setminus (\pi^{-1}\mathcal{T} \cup \mathcal{S}) \coprod (\mathcal{T} \cup \pi^{-1}\mathcal{S}) \tag{4.8.3}$$

such that the pair of chords $\pi^{-1}(s) \mapsto s$ and $a \mapsto \pi(a)$ are noncrossing for all $s \in \mathcal{S}$, and likewise the chords $\pi^{-1}(t) \mapsto t$ and $a \mapsto \pi(a)$ are noncrossing for all $t \in \mathcal{T}$.

In (4.8.2), let us clarify that the use of \setminus implies that the second set is contained in the first. (We do not adopt that convention in most other parts of the chapter.) However, it is not important that the sets $\pi^{-1}(\mathcal{T}), \mathcal{S}$ are disjoint, and it is also not important that the sets \mathcal{S} and \mathcal{T} are disjoint (i.e., we allow for removing an element that is in \mathcal{S} and then adding it back in if it is in \mathcal{T}).

We will establish this claim by induction on $\ell(f) - \ell(i)$ and then explain why it implies the statement in the lemma.

The base case of (4.8.2) holds with $\mathcal{S} = \mathcal{T} = \emptyset$. The subsets L and R only change meaning when we toggle at either L or R . If we toggle at R , things look locally like

$$L \xrightarrow[\underline{a}]{\pi(a)} R \xrightarrow[\pi^{-1}(t)]{t} X. \quad (4.8.4)$$

Let us denote by L', R' the new versions of L and R after the toggle. Then $R' = X = R \setminus \pi^{-1}(t) \cup t$. The subset L' is subset obtained by toggling at R ; we clearly also have $L' = L \setminus \pi^{-1}(t) \cup t$. So L', R' both evolve according to the formula (4.8.2) in this case. The claimed statement that these chords are noncrossing holds by assumption. Note also that $t \neq \pi(a)$. The argument in the case that we toggle at L rather than at R is similar, with the local picture looking like

$$X \xrightarrow[\pi^{-1}(s)]{s} L \xrightarrow[\underline{a}]{\pi(a)} R \quad (4.8.5)$$

and the subsets evolving according to the formula $L' = L \setminus s \cup \pi^{-1}(s)$ and $R' = R \setminus s \cup \pi^{-1}(s)$. Note again that $s \neq a, \pi(a)$. The claim holds by induction.

Since the chords $\pi^{-1}(s) \mapsto s$ and $a \mapsto \pi(a)$ are noncrossing, we either have that $\{s, \pi^{-1}(s)\} \subset (a, \pi(a))$ or that $\{s, \pi^{-1}(s)\} \subset (\pi(a), a)$ (with both of these considered as cyclic subintervals of $[n]$). And similarly for $\{\pi^{-1}(t), t\}$. From (4.8.2), it follows that

$$\#(R \cap (a, \pi(a))) = \#\vec{I}_{a+1} \cap (a, \pi(a)).$$

If $J = L \setminus a \cup y = R \setminus \pi(a) \cup y$ where $y <_a \pi(a)$, then

$$\#(J \cap (a, \pi(a))) = \#(R \cap (a, \pi(a))) + 1 > \#(\vec{I}_{a+1} \cap (a, \pi(a)))$$

so that $J \notin \mathcal{M}_\pi$ using Oh's Theorem.

Likewise, let $J = L \setminus y \cup \pi(a)$ in the situation $\pi(a) <_a y$. Then

$$\#\vec{I}_a \cap [a, \pi(a)] = \#(L \cap [a, \pi(a)]) = \#(J \cap [a, \pi(a)]) - 1,$$

so that $J \notin \mathcal{M}_\pi$ using Oh's Theorem. □

Proof of Theorem 4.5.19

By Remark 4.5.9, aligned toggles correspond to those in which the Plücker relation has signs $I_i I'_i = I_{i-1} I_{i+1} + S_1 S_2$. Such a relation “looks like” the three-term Plücker relation encoding a square move on weakly separated collections. However, such a Plücker relation does not necessarily correspond to a square move on weakly separated collections; that is, performing an aligned toggle does not preserve weak separation. So not all of the necklaces $\mathcal{S}_{\bullet, \iota, \pi}$ with $\iota \leq_o \pi$ are weakly separated.

Recall our general setup: we have $i \leq_R f$ associated to permutations ι, π of type (k, n) . We define $\mu = \iota^{-1} \pi \iota$ which is a permutation of type (k, n) , associated to $m \in \text{Bound}(k, n)$. By Lemma 4.5.17, $m = i^{-1} f i$. We always have $\ell(m) \leq \ell(f)$ and we want to characterize when $\ell(m) = \ell(f)$.

To simplify statements, let $r = f^{-1} i$, so $m = r^{-1} i$.

Lemma 4.8.1. *We have $\ell(m) < \ell(f)$ if and only if there exists a transposition $t \in T$ satisfying both $\ell(tr) < \ell(r)$ and $\ell(ti) < \ell(i)$.*

In other words, if $t = t_{ij}$, then the values i and j are “out of order” in both ρ and ι (when both permutations are appropriately upgraded to affine permutations).

Proof. Since $i \leq_R f$, the factorization $f = ir^{-1}$ is length-additive: $\ell(f) = \ell(i) + \ell(r^{-1})$. So $\ell(m) = \ell(f)$ if and only if the factorization $m = r^{-1}i$ is length-additive: $\ell(r^{-1}i) = \ell(r^{-1}) + \ell(i)$.

By Lemma 4.3.24, $\ell(r^{-1}i) = \ell(r^{-1}) + \ell(i)$ if and only if $T_R(r^{-1}) \cap T_L(i) = \emptyset$. Also $T_R(r^{-1}) = T_L(r)$, so we are done. □

We now prove half of Theorem 4.5.19, namely that $\ell(m) = \ell(f)$ is sufficient to guarantee that $\mathcal{S}_{\bullet, \iota, \pi}$ is weakly separated.

Proof of sufficiency. We will suppose that \mathcal{S} is not weakly separated and show that there exists a transposition $t \in T$ as in the statement of Lemma 4.8.1.

First we rephrase weak separation of \mathcal{S} as a condition on the removal and insertion permutations ρ and ι . A 4-tuple of circularly ordered numbers $a < b < c < d$ are a witness for nonseparation of \mathcal{S} if and only if there are values $x, y \in [n]$, such that

$$\{a, c\} \subset \iota([y, x]) \text{ and } \{b, d\} \subset \rho([y, x]) \tag{4.8.6}$$

$$\{a, c\} \subset \rho([x, y]) \text{ and } \{b, d\} \subset \iota([x, y]). \tag{4.8.7}$$

Visually, we can “chop” \mathcal{S} in the positions I_x and I_y , breaking $[n] = \beta_1 \sqcup \beta_2$ in two cyclic intervals β_i . In β_1 we see $\{a, c\}$ in the insertion permutation and $\{b, d\}$ in the removal permutation while in β_2 we see the opposite.

Now we switch from thinking about permutations ρ, ι to thinking about affine permutations. We consider the two-line notation (4.8.1) (extended bi-infinitely and n -periodically in both directions) whose numerator is i and whose denominator is $r = f^{-1}i$. Reducing values modulo n yields the permutations ι, ρ respectively.

As in the proof of Lemma 4.5.17, we can reach this two-line notation by starting with the two-line notation whose numerator is f and whose denominator is the identity $e_0 \in \tilde{S}_n^0$, and n -periodically performing swaps of adjacent columns. In particular, any column vector $\begin{smallmatrix} \beta \\ \alpha \end{smallmatrix}$ appearing in the two-line notation satisfies $\alpha \leq \beta \leq \alpha + n$.

As in the proof of Lemma 4.5.17, the appearance of any $x \in \mathbb{Z}$ in the top row is weakly to the left of x in the bottom row.

Suppose $a < b < c < d$ are a witness against weak separation as in (4.8.6). We can uniquely lift these to linearly ordered numbers $a < b' < c' < d' \in \mathbb{N}$ such that $b' \in \{b, b + n\}$ and so on. Initially, the numbers a, b', c', d' appear sorted in the order $a, \dots, b', \dots, c', \dots, d'$ in the denominator of the two-line notation. To reach \mathcal{S} , we perform a sequence of column swaps so that $\{a, c'\}$ and $\{b', d'\}$ are adjacent to each other in the bottom row.

For example, this might happen by starting with $a, \dots, b', \dots, c', \dots, d'$ in the bottom row, performing swaps until we reach $a, \dots, b', c', \dots, d$ with b', c' adjacent, and then performing the swap that switches b', c' yielding $a, \dots, c', b', \dots, d$. Once we have done this, the values c', b' henceforth remain out of order in the bottom row, and in particular we would have $\ell(t_{(b',c')r}) < \ell(r)$. If we perform a further sequence of swaps and arrive at the picture

$$\begin{array}{c} \{b, d\} \dots \{a, c\} \\ \{a, c\} \dots \{b, d\} \end{array}$$

modulo n , we conclude that the picture in fact looks like

$$\begin{array}{c} \{b', d'\} \dots \{a+n, c'+n\} \dots \{b'+n, d'+n\} \\ \{a, c'\} \dots \{b', d'\} \dots \{a'+n, c'+n\} \end{array}'$$

using the fact a in the top row appears left of a in the bottom row, etc. The values b', c' are also out of order in the numerator, i.e. we have $\ell(t_{b'c'i}) < \ell(i)$, as desired.

We have been considering the special case where b' swaps past c' , but it is straightforward to see that it is necessary to perform at least one of the swaps (d past a , a past b' , b' past c' , or c' past d') and the argument is identical. \square

Now we prove the second half of Theorem 4.5.19, i.e. that the condition $\ell(m) = \ell(f)$ is necessary for the necklace \mathcal{S} to be weakly separated.

Proof of necessity. We will show that if there exists $a < b$ such that $\ell(t_{abr}) < \ell(r)$ and $\ell(t_{abi}) < \ell(i)$, then we can chop the two-line notation (4.8.1) in two pieces as in (4.8.6) and (4.8.7). As in the above proof of sufficiency, we work with two-line notation for affine permutations. By assumption, the two-line notations looks like

$$\begin{array}{c} \dots b \dots a \dots \dots \\ \dots \dots b \dots a \dots \end{array} \tag{4.8.8}$$

The relative positions of the a in the numerator and the b in the denominator are not important for our argument.

We chop the necklace as indicated by vertical bars

$$\begin{array}{c} \dots b \left| \dots a \dots \right| \dots \\ \dots \left| \dots b \dots \right| a \dots \end{array} \tag{4.8.9}$$

(that is, just *after* the b in the top row and just before the a in the bottom row). Let $\mathcal{B}^- := (-\infty, a) \cap$ bottom row and $\mathcal{T}^- := (-\infty, a) \cap$ top row. We claim that $\mathcal{B}^- \setminus \mathcal{T}^-$ is nonempty. We have that $\pi^{-1}(a) \in \mathcal{B}^-$. Then the claim follows from noting that if $z \in \mathcal{T}^-$ then there exists an element of \mathcal{B}^- which is strictly less than z (namely, the element $\pi^{-1}(z)$).

We can likewise set $\mathcal{B}^+ := (b, \infty) \cap$ bottom row and $\mathcal{T}^+ := (b, \infty) \cap$ top row. Then $\pi(b) \in \mathcal{T}^+$ and we claim that $\mathcal{T}^+ \setminus \mathcal{B}^+$ is nonempty. This follows similarly from as above, noting that if $z \in \mathcal{B}^+$ then there exists an element of \mathcal{T}^+ which is strictly greater than z (namely, the element $\pi(z)$).

Letting $z_- \in \mathcal{B}^- \setminus \mathcal{T}^-$, $z_+ \in \mathcal{T}^+ \setminus \mathcal{B}^+$, we have $z_- < a < b < z_+$ are a witness against weak separation. \square

Proof of Theorem 4.7.4

Our main tool to prove Theorem 4.7.4 are the plabic tilings of [39, Section 9]. We briefly review the definition here.

Let p_1, \dots, p_n be the vertices of a regular n -gon in the plane, listed clockwise. For $I \subset [n]$, we use the notation $p(I) := \sum_{i \in I} p_i$. As usual, we abbreviate $X \cup \{a\}$ as Xa .

Given a weakly separated collection $\mathcal{C} \subset \binom{[n]}{k}$, the associated plabic tiling $\mathcal{T}(\mathcal{C})$ is a 2-dimensional CW-complex embedded in \mathbb{R}^2 . The vertices are $p(I) : I \in \mathcal{C}$. Faces correspond to nontrivial black and white cliques in \mathcal{C} . For $X \in \binom{[n]}{k-1}$, the white clique $\mathcal{W}(X)$ consists of all $I \in \mathcal{C}$ which contain X . Similarly, for $X \in \binom{[n]}{k+1}$, the black clique $\mathcal{B}(X)$ consists of all $I \in \mathcal{C}$ which are contained in X . A clique is nontrivial if it has more than two elements. The elements of a white clique, for example, are Xa_1, \dots, Xa_r , where a_1, \dots, a_r are cyclically ordered; we have edges between $p(Xa_i)$ and $p(Xa_{i+1})$ in $\mathcal{T}(\mathcal{C})$. The edges between vertices in a black clique are similar.

Lemma 4.8.2. *Let $\mathcal{S}_{\rho, \iota, \pi}$ be a generalized necklace such that $\iota \leq_{\circ} \pi$, and say $\mathcal{S} = (I_1, \dots, I_n)$. Then \mathcal{S} does not contain a quadruple $I_a, I_{a+1}, I_b, I_{b+1}$ such that either $(I_a, I_{a+1}) = (Xu, Xw)$ and $(I_b, I_{b+1}) = (Xv, Xx)$, or $(I_a, I_{a+1}) = (X \setminus u, X \setminus w)$ and $(I_b, I_{b+1}) = (X \setminus v, X \setminus x)$, where $u \rightarrow w$ and $v \rightarrow x$ are crossing chords.*

Proof. We argue by contradiction. Suppose we have $(I_a, I_{a+1}) = (Xu, Xw)$ and $(I_b, I_{b+1}) = (Xv, Xx)$ for crossing chords $u \rightarrow w$ and $v \rightarrow x$. Since u is removed from I_a , we have that $a = \rho^{-1}(u)$. We also have that $w = \pi(u)$. Since the chords $u \rightarrow w$ and the chords $v \rightarrow x$ cross, we know that one of v, x is in the cyclic interval from u to $\pi(u)$. Let's say it's x (the other case is identical). That is, we have $x <_u \pi(u)$. By Lemma 4.5.7, this means that $I_{\rho^{-1}(u)} \setminus u \cup x = Xx$ is not in the matroid \mathcal{M}_{π} . But by Theorem 4.5.14, \mathcal{S} is a unit necklace and so in particular, all terms are in \mathcal{M}_{π} , a contradiction.

The other case is identical. □

Proof of Theorem 4.7.4. Let $\mathcal{S} = \mathcal{S}_{\rho, \iota, \pi}$ be a weakly separated necklace with $\iota \leq_{\circ} \pi$. Suppose that one can perform an aligned toggle at position j , resulting in a necklace $\mathcal{S}' = \mathcal{S}_{\rho', \iota', \pi}$ that is also weakly separated. We would like to produce relabeled plabic graphs G^{ρ} and $H^{\rho'}$ with trip permutation π whose target seeds are quasi-equivalent.

If $\iota_j = \rho_j$, then every relabeled plabic graph with boundary ρ has a white lollipop at ρ_j . In this case, it is easy to find relabeled plabic graphs G^{ρ} and $H^{\rho'}$ whose target seeds are identical (just move the white lollipop appropriately). Similarly, the $\iota_{j-1} = \rho_{j-1}$ case is easy, so we may assume $\iota_{j-1}, \rho_{j-1}, \iota_j, \rho_j$ are distinct.

We are in the situation where $I_{j-1} = Suv, I_j = Svx, I_{j+1} = Swx$, with $u < v < w < x$ in cyclic order. Toggling at j produces $I'_j = Suw$. Since \mathcal{S} and $\mathcal{S}' = \mathcal{S} \setminus I_j \cup I'_j$ are both weakly separated, [40, Lemma 5.1] implies that $\mathcal{S} \cup \{Sux, Svw\}$ is also weakly separated. By the proof of Proposition 4.5.10, at most one of Sux, Svw is in the matroid \mathcal{M}_{π} .

Let \mathcal{C} be a maximal weakly separated collection containing $\mathcal{S} \cup \{Sux, Svw\}$, and let $\mathcal{T}(\mathcal{C})$ be the corresponding plabic tiling.

Notice that $I_j \neq I_a$ for any $a \neq j$, since otherwise \mathcal{S}' would not be weakly separated. Let (J_1, \dots, J_r) be the tuple obtained by deleting all adjacent occurrences of the same subset in \mathcal{S} (i.e. if $I_a = I_{a+1} = \dots = I_b$, we delete I_{a+1}, \dots, I_b). Note we have not deleted I_j .

We will show our result first in the case when all the subsets J_1, \dots, J_r are distinct. In this case, (J_1, \dots, J_r) is a generalized cyclic pattern of [10]. It satisfies conditions (C1-C4) of [10]; (C1), (C2), and (C4) are immediate and (C3) follows from Lemma 4.8.2. By [10, Proposition 5.2], the polygonal curve ζ through $p(J_1), p(J_2), \dots, p(J_r), p(J_1)$ (in that order) is non-self-intersecting. It is not hard to see that the line from $p(J_a)$ to $p(J_{a+1})$ is either an edge of $T(\mathcal{C})$ or it cuts across a face of $T(\mathcal{C})$. In particular, ζ does not intersect any edges of $\mathcal{T}(\mathcal{C})$ in their interior.

In $\mathcal{T}(\mathcal{C})$, $p(I_{j-1}), p(I_j), p(I_{j+1}), p(Sux), p(Svw)$ are (up to rotation) arranged

$$\begin{array}{c}
 p(Sux) \\
 | \\
 p(I_{j-1}) - p(I_j) - p(I_{j+1}) \\
 | \\
 p(Svw)
 \end{array}$$

with edges as shown. There are no other edges involving $p(I_j)$. From this picture, we see that exactly one of $\{p(Sux), p(Svw)\}$, say $p(R)$, is inside the curve ζ .

As noted in [11, proof of Theorem 6.3], if one takes the part of $\mathcal{T}(\mathcal{C})$ enclosed in ζ and constructs the dual plabic graph (with boundary vertices labeled so that the target label of the face dual to $p(I)$ is I), one obtains a relabeled plabic graph G^ρ with trip permutation π . By Proposition 4.6.12, the target face labels of G^ρ are elements of \mathcal{M}_π , since $\Delta_{\tilde{I}(f)}^\bullet$ does not identically vanish on $\tilde{\Pi}_\pi^\circ$. Thus, of the two vertices $p(Sux), p(Svw)$, the one $p(R)$ that lies inside ζ is the one where $R \in \mathcal{M}_\pi$.

Now, let $\mathcal{C}' := \mathcal{C} \setminus I_j \cup I'_j$; that is, \mathcal{C}' is obtained from \mathcal{C} by performing a square move at I_j . Note that the tiling $\mathcal{T}(\mathcal{C}')$ differs from $\mathcal{T}(\mathcal{C})$ only inside the rectangle with vertices $p(I_{j-1}), p(I_{j+1}), p(Sux), p(Svw)$. Let ζ' be the polygonal curve in $\mathcal{T}(\mathcal{C}')$ obtained from ζ by replacing the vertex $p(I_j)$ with the vertex $p(I'_j)$. Again, ζ' is a non-self-intersecting curve. Let $H^{\rho'}$ be the relabeled plabic graph dual to the part of $\mathcal{T}(\mathcal{C}')$ enclosed by ζ' .

We claim that the target seeds $\Sigma_{G^\rho}^T$ and $\Sigma_{H^{\rho'}}^T$ are quasi-equivalent. Notice that the interior face labels of the two relabeled plabic graphs agree, and all boundary face labels agree except I_j and I'_j . So the only thing to check is the \hat{y} condition. For all faces except the one labeled by R , no arrows or neighbors have changed, so those \hat{y} variables have not changed. Around R , in $\Sigma_{G^\rho}^T$ we see the picture below on the left; in $\Sigma_{H^{\rho'}}^T$, we see the picture below on the right. If the dotted (resp. dashed) arrow is present on the left, it is not on the right. There may be other arrows to other vertices, but they are the same in both seeds; the arrows may also all be reversed. For simplicity, we write I for Δ_I .

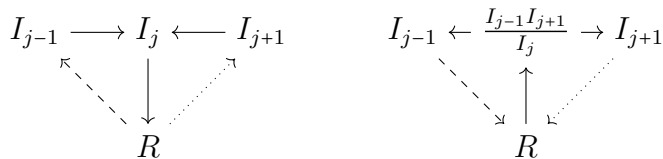

By Proposition 4.5.10, $\Delta_{I'_j}$ is equal to $\frac{\Delta_{I_{j-1}}\Delta_{I_{j+1}}}{\Delta_{I_j}}$. It is easy to see that $\hat{y}(\Delta_R)$ is the same in both seeds.

Now, we deal with the case when the tuple (J_1, \dots, J_r) contains some repeats. In this case, the polygonal curve ζ through $p(J_1), p(J_2), \dots, p(J_r), p(J_1)$ will have self-intersections. However, Lemma 4.8.2 implies that these self-intersections will occur only at $p(J_a)$, where J_a is some subset that appears more than once.

Break the tuple (J_1, \dots, J_r) up into sub-tuples $\mathcal{K}^1, \dots, \mathcal{K}^q$ where $\mathcal{K}^i = (J_a, J_{a+1}, \dots, J_b)$ contains no repeated elements and is as long as possible. Likewise, break ζ up into polygonal curves ζ^1, \dots, ζ^q passing through the elements of subtuples. Each of these subtuples is a generalized cyclic pattern a la [10], so by the argument above, ζ^i encloses a part of $\mathcal{T}(\mathcal{C})$ which is dual to a relabeled plabic graph with boundary faces \mathcal{K}^i . We claim that the union of the parts of $\mathcal{T}(\mathcal{C})$ enclosed by ζ^i is dual to a relabeled plabic graph with boundary faces J_1, \dots, J_r . The only thing to worry about is if some curve ζ^i encloses ζ^ℓ . In this case, in the relabeled plabic graph with boundary faces \mathcal{K}^i , we would have \mathcal{K}^ℓ appear as internal face labels. That is to say, in the underlying plabic graph with boundary faces $\rho^{-1}(\mathcal{K}^i)$, we would have $\rho^{-1}(\mathcal{K}^\ell)$ appear as internal face labels, so in the dual plabic tiling, $\rho^{-1}(\mathcal{K}^\ell)$ would lie inside the polygonal curve through $\rho^{-1}(\mathcal{K}^i)$.

But this is impossible. Let $\mu = \rho^{-1}\iota$. Notice that the Grassmann necklace $\vec{\mathcal{I}}_\mu = \rho^{-1}(\mathcal{I})$ is not connected (in the sense of [39, Definition 5.4]), and the sub-tuples $\rho^{-1}(\mathcal{K}^i)$ are the connected components of $\vec{\mathcal{I}}_\mu$ of size greater than one. Plabic graphs with trip permutation μ are not connected, and each connected component of such a graph is encircled by boundary faces labeled with $\rho^{-1}(\mathcal{K}^i)$ for some i ; this follows from [39, Proposition 9.7]. In the dual plabic tiling, the polygonal curve through $\rho^{-1}(\mathcal{K}^i)$ does not enclose $\rho^{-1}(\mathcal{K}^\ell)$ for any i, ℓ .

So we take G^ρ to be the plabic graph dual to the parts of $\mathcal{T}(\mathcal{C})$ which lie inside of ζ^i for some i . The rest of the argument proceeds as in the first case, noting that I_j is in only one \mathcal{K}^i , and so $p(I_j)$ is only in one curve ζ^i . \square

Bibliography

- [1] Ibrahim Assem, Daniel Simson, and Andrzej Skowroński. *Elements of the representation theory of associative algebras. Vol. 1*. Vol. 65. London Mathematical Society Student Texts. Techniques of representation theory. Cambridge University Press, Cambridge, 2006, pp. x+458.
- [2] Pierre Baumann, Joel Kamnitzer, and Peter Tingley. “Affine Mirković-Vilonen polytopes”. In: *Publ. Math. Inst. Hautes Études Sci.* 120 (2014), pp. 113–205. ISSN: 0073-8301.
- [3] Arkady Berenstein, Sergey Fomin, and Andrei Zelevinsky. “Cluster algebras. III. Upper bounds and double Bruhat cells”. In: *Duke Math. J.* 126.1 (2005), pp. 1–52. ISSN: 0012-7094.
- [4] Anders Björner and Francesco Brenti. *Combinatorics of Coxeter groups*. Vol. 231. Graduate Texts in Mathematics. Springer, New York, 2005, pp. xiv+363.
- [5] Aslak B. Buan, Osamu Iyama, Idun Reiten, and Jeanne Scott. “Cluster structures for 2-Calabi-Yau categories and unipotent groups”. In: *Compos. Math.* 145.4 (2009), pp. 1035–1079. ISSN: 0010-437X.
- [6] Philippe Caldero and Bernhard Keller. “From triangulated categories to cluster algebras. II”. In: *Ann. Sci. École Norm. Sup. (4)* 39.6 (2006), pp. 983–1009. ISSN: 0012-9593.
- [7] Gérard Cauchon. “Spectre premier de $O_q(M_n(k))$: image canonique et séparation normale”. In: *J. Algebra* 260.2 (2003), pp. 519–569. ISSN: 0021-8693.
- [8] Frédéric Chapoton, Sergey Fomin, and Andrei Zelevinsky. “Polytopal realizations of generalized associahedra”. In: *Canad. Math. Bull.* 45 (2002), pp. 537–566.
- [9] Nicolas Chevalier. *Algèbres amassées et positivité*. Thesis (Ph.D.)—Université de Caen. 2012, (no paging).
- [10] Vladimir I. Danilov, Alexander V. Karzanov, and Gleb A. Koshevoy. “Combined tilings and separated set-systems”. In: *Selecta Math. (N.S.)* 23.2 (2017), pp. 1175–1203. ISSN: 1022-1824.
- [11] Miriam Farber and Pavel Galashin. “Weak separation, pure domains and cluster distance”. In: *Selecta Math. (N.S.)* 24.3 (2018), pp. 2093–2127. ISSN: 1022-1824.

- [12] Vladimir Fock and Alexander Goncharov. “Cluster \mathcal{X} -varieties, amalgamation, and Poisson-Lie groups”. In: *Algebraic geometry and number theory*. Vol. 253. Progr. Math. Birkhäuser Boston, Boston, MA, 2006, pp. 27–68.
- [13] Sergey Fomin and Pavlo Pylyavskyy. “Tensor diagrams and cluster algebras”. In: *Adv. Math.* 300 (2016), pp. 717–787. ISSN: 0001-8708.
- [14] Sergey Fomin, Lauren Williams, and Andrei Zelevinsky. “Introduction to cluster algebras. Chapters 4-5”. Preprint, [arXiv:1707.07190](https://arxiv.org/abs/1707.07190). 2017.
- [15] Sergey Fomin and Andrei Zelevinsky. “Cluster algebras. I. Foundations”. In: *J. Amer. Math. Soc.* 15.2 (2002), pp. 497–529. ISSN: 0894-0347.
- [16] Nicolas Ford and Khrystyna Serhiyenko. “Green-to-red sequences for positroids”. In: *J. Combin. Theory Ser. A* 159 (2018), pp. 164–182. ISSN: 0097-3165.
- [17] Chris Fraser. “Quasi-homomorphisms of cluster algebras”. In: *Adv. in Appl. Math.* 81 (2016), pp. 40–77. ISSN: 0196-8858.
- [18] Chris Fraser and Melissa Sherman-Bennett. “Positroid cluster structures from relabeled plabic graphs”. Preprint, [arXiv:2006.10247](https://arxiv.org/abs/2006.10247). 2020.
- [19] Pavel Galashin and Thomas Lam. “Positroid varieties and cluster algebras”. Preprint, [arXiv:1906.03501](https://arxiv.org/abs/1906.03501). 2019.
- [20] Christof Geiss, Bernard Leclerc, and Jan Schröer. “Kac-Moody groups and cluster algebras”. In: *Adv. Math.* 228.1 (2011), pp. 329–433. ISSN: 0001-8708.
- [21] Christof Geiss, Bernard Leclerc, and Jan Schröer. “Partial flag varieties and preprojective algebras”. In: *Ann. Inst. Fourier (Grenoble)* 58.3 (2008), pp. 825–876. ISSN: 0373-0956.
- [22] Michael Gekhtman, Michael Shapiro, and Alek Vainshtein. “Cluster algebras and Poisson geometry”. In: *Mosc. Math. J.* 3.3 (2003), pp. 899–934, 1199. ISSN: 1609-3321.
- [23] J. Golden, A. Goncharov, M. Spradlin, C. Vergu, and A. Volovich. “Motivic amplitudes and cluster coordinates”. In: *Journal of High Energy Physics* 2014.91 (2014). DOI: [10.1007/jhep01\(2014\)091](https://doi.org/10.1007/jhep01(2014)091).
- [24] Mark Gross, Paul Hacking, Sean Keel, and Maxim Kontsevich. “Canonical bases for cluster algebras”. In: *J. Amer. Math. Soc.* 31.2 (2018), pp. 497–608. ISSN: 0894-0347.
- [25] Seok-Jin Kang, Masaki Kashiwara, Myungho Kim, and Se-Jin Oh. “Monoidal categorification of cluster algebras”. In: *J. Amer. Math. Soc.* 31 (2018), pp. 349–426. ISSN: 0894-0347.
- [26] Rachel Karpman. “Bridge graphs and Deodhar parametrizations for positroid varieties”. In: *J. Combin. Theory Ser. A* 142 (2016), pp. 113–146. ISSN: 0097-3165.
- [27] David Kazhdan and George Lusztig. “Representations of Coxeter groups and Hecke algebras”. In: *Invent. Math.* 53.2 (1979), pp. 165–184. ISSN: 0020-9910.

- [28] Allen Knutson, Thomas Lam, and David E. Speyer. “Positroid varieties: juggling and geometry”. In: *Compos. Math.* 149.10 (2013), pp. 1710–1752. ISSN: 0010-437X.
- [29] Thomas Lam and Lauren Williams. “Total positivity for cominuscule Grassmannians”. In: *New York J. Math.* 14 (2008), pp. 53–99. ISSN: 1076-9803.
- [30] Bernard Leclerc. “Cluster structures on strata of flag varieties”. In: *Adv. Math.* 300 (2016), pp. 190–228. ISSN: 0001-8708.
- [31] George Lusztig. “Canonical bases arising from quantized enveloping algebras”. In: *J. Amer. Math. Soc.* 3.2 (1990), pp. 447–498. ISSN: 0894-0347.
- [32] George Lusztig. “Total positivity in partial flag manifolds”. In: *Represent. Theory* 2 (1998), pp. 70–78. ISSN: 1088-4165.
- [33] George Lusztig. “Total positivity in reductive groups”. In: *Lie theory and geometry*. Vol. 123. Progr. Math. Boston, MA: Birkhäuser Boston, 1994, pp. 531–568.
- [34] Robert J. Marsh and Jeanne S. Scott. “Twists of Plücker coordinates as dimer partition functions”. In: *Comm. Math. Phys.* 341.3 (2016), pp. 821–884. ISSN: 0010-3616.
- [35] Greg Muller. “Locally acyclic cluster algebras”. In: *Adv. Math.* 233 (2013), pp. 207–247. ISSN: 0001-8708.
- [36] Greg Muller and David E. Speyer. “Cluster algebras of Grassmannians are locally acyclic”. In: *Proc. Amer. Math. Soc.* 144.8 (2016), pp. 3267–3281. ISSN: 0002-9939.
- [37] Greg Muller and David E. Speyer. “The twist for positroid varieties”. In: *Proc. Lond. Math. Soc. (3)* 115.5 (2017), pp. 1014–1071. ISSN: 0024-6115.
- [38] Suho Oh. “Positroids and Schubert matroids”. In: *J. Combin. Theory Ser. A* 118.8 (2011), pp. 2426–2435. ISSN: 0097-3165.
- [39] Suho Oh, Alexander Postnikov, and David E. Speyer. “Weak separation and plabic graphs”. In: *Proc. Lond. Math. Soc. (3)* 110.3 (2015), pp. 721–754. ISSN: 0024-6115.
- [40] Suho Oh and David E. Speyer. “Links in the complex of weakly separated collections”. In: *J. Comb.* 8.4 (2017), pp. 581–592. ISSN: 2156-3527.
- [41] Alexander Postnikov. “Total positivity, Grassmannians, and networks”. Preprint, [arXiv:math/0609764](https://arxiv.org/abs/math/0609764). 2006.
- [42] Roger W. Richardson. “Intersections of double cosets in algebraic groups”. In: *Indag. Math. (N.S.)* 3.1 (1992), pp. 69–77. ISSN: 0019-3577.
- [43] Konstanze Rietsch. *Total positivity and real flag varieties*. Thesis (Ph.D.)—Massachusetts Institute of Technology. ProQuest LLC, Ann Arbor, MI, 1998, (no paging).
- [44] Claus Michael Ringel. “The preprojective algebra of a quiver”. In: *Algebras and modules, II (Geiranger, 1996)*. Vol. 24. CMS Conf. Proc. Amer. Math. Soc., Providence, RI, 1998, pp. 467–480.
- [45] Ralf Schiffler. *Quiver representations*. CMS Books in Mathematics/Ouvrages de Mathématiques de la SMC. Springer, Cham, 2014, pp. xii–230.

- [46] Jeanne S. Scott. “Grassmannians and cluster algebras”. In: *Proc. London Math. Soc.* (3) 92.2 (2006), pp. 345–380. ISSN: 0024-6115.
- [47] Khrystyna Serhiyenko, Melissa Sherman-Bennett, and Lauren Williams. “Cluster structures in Schubert varieties in the Grassmannian”. In: *Proc. London Math. Soc.* (3) 119.6 (2019), pp. 1694–1744.
- [48] John R. Stembridge. “On the fully commutative elements of Coxeter groups”. In: *J. Algebraic Combin.* 5.4 (1996), pp. 353–385. ISSN: 0925-9899.
- [49] Lauren K. Williams. “Shelling totally nonnegative flag varieties”. In: *J. Reine Angew. Math.* 609 (2007), pp. 1–21. ISSN: 0075-4102.
- [50] Yan Zhou. “Cluster Structures and Subfans in Scattering Diagrams”. In: *Symmetry, Integrability and Geometry: Methods and Applications* (Mar. 2020). ISSN: 1815-0659.