

Lawrence Berkeley National Laboratory

Recent Work

Title

AN ANALOG STOKE AND MULTIPLEXER FOR PULSE HEIGHT ANALYSIS

Permalink

<https://escholarship.org/uc/item/1x38t5cm>

Authors

Robinson, L.B.

Gin, F.

Cingolani, H.

Publication Date

1969-04-01

Submitted to Nuclear Instruments and
Methods

UCRL-18867
Preprint

cy. 2
(cy. 2 msg)

RECEIVED
LAWRENCE
RADIATION LABORATORY

MAY 27 1969

LIBRARY AND
DOCUMENTS SECTION

AN ANALOG STORE AND MULTIPLEXER
FOR PULSE HEIGHT ANALYSIS

L. B. Robinson, F. Gin and H. Cingolani

April 1969

AEC Contract No. W-7405-eng-48

TWO-WEEK LOAN COPY

This is a Library Circulating Copy
which may be borrowed for two weeks.
For a personal retention copy, call
Tech. Info. Division, Ext. 5545

LAWRENCE RADIATION LABORATORY
UNIVERSITY of CALIFORNIA BERKELEY

UCRL-18867

DISCLAIMER

This document was prepared as an account of work sponsored by the United States Government. While this document is believed to contain correct information, neither the United States Government nor any agency thereof, nor the Regents of the University of California, nor any of their employees, makes any warranty, express or implied, or assumes any legal responsibility for the accuracy, completeness, or usefulness of any information, apparatus, product, or process disclosed, or represents that its use would not infringe privately owned rights. Reference herein to any specific commercial product, process, or service by its trade name, trademark, manufacturer, or otherwise, does not necessarily constitute or imply its endorsement, recommendation, or favoring by the United States Government or any agency thereof, or the Regents of the University of California. The views and opinions of authors expressed herein do not necessarily state or reflect those of the United States Government or any agency thereof or the Regents of the University of California.

AN ANALOG STORE AND MULTIPLEXER
FOR PULSE-HEIGHT ANALYSIS

L. B. Robinson, F. Gin, and H. Cingolani*

Lawrence Radiation Laboratory
University of California
Berkeley, California

April 1969

ABSTRACT

The report describes an electronic analog pulse storage unit. Used in conjunction with on-line computers, the unit allows high-resolution pulse-height analysis of eight-parameter coincidence events by use of a single ADC.

I. INTRODUCTION

In multiparameter pulse-height analysis experiments, an "event" consists of several analog voltage pulses in coincidence. These pulses must all be digitally encoded. Average counting rates are usually low in such experiments, but since several pulses appear simultaneously, processing must be done in parallel, often requiring two or more analog-to-digital converters (ADC).

An alternative to providing parallel ADC's is to store the pulses in analog form and process them one at a time, with a single ADC. This procedure becomes more attractive economically as the number of parameters is increased. The major problem is to avoid adding any uncertainty to the pulse height due to its having been temporarily stored. Since the storage time may vary, this means that the storage device must have very good long-term memory.

A suitable analog storage circuit was developed by Goulding for use as the stretcher in a 4096-channel ADC¹⁾. This circuit provides a drift of less than 1 mV per millisecond, on an output waveform whose amplitude (0.03 to 10 V) corresponds linearly to a 1- μ s input pulse.

Figure 1 is a block diagram of the analog store and multiplexer, and indicates the way in which analog pulse information is first stored in the stretchers, then transmitted to the ADC. A step-by-step explanation of the operation is included below. In fig. 2, a circuit diagram of the stretcher is given. A detailed description of the stretcher

operation is found in reference 1. Several analog storage and multiplex units have been used in data systems at LRL in Berkeley for several years. The main elements of a typical system are shown in fig. 3.

An analog multiplexer unit contains eight stretchers, each with an input gate and low-level discriminator. These are tied to control logic and an output multiplexer. The multiplexer samples each stretcher level upon demand, and generates a pulse whose amplitude is proportional to the stretcher voltage. This pulse usually is fed to a 4096-channel ADC of the type described in reference 1, but any other ADC could be used. No measurable degradation in resolution has been detected in high-resolution measurements of complex gamma-ray spectra when the analog store was inserted between the amplifier and ADC.

One of the critical elements of this unit is the multiplex circuit which converts the voltage levels output by the stretchers into voltage pulses suitable for input to the ADC. The relatively simple circuit to accomplish this job is shown schematically in fig. 4.

By the use of diodes in pairs, to compensate for changes of voltage with temperature, thermal drift problems in the multiplex circuit are reduced so that the dominant cause of drift is in the stretcher unit itself. Thermal base-line drift in the stretcher has usually not been a problem under our operating conditions (temperature stable to 2° or 3°C). In some situations, the observed temperature dependence of 4 mV per 10°C has required the use of base-line stabilization techniques.

II. OPERATION

Operation of the circuit can be understood with the aid of fig. 1. Input analog pulses are fed directly (usually in coincidence) to each stretcher from a corresponding amplifier and detector. A low-level discriminator included with each stretcher triggers upon receipt of an input pulse.

The output from any one of the discriminators will trigger a 6- μ s delay (D1), at the end of which a general CLEAR pulse is triggered. Unless a validation or "coincidence" pulse is received within $\pm 3 \mu$ s of the first analog input pulse, the CLEAR pulse will reset all stretchers, leaving them ready to accept new information. If the coincidence pulse is received, the CLEAR pulse is inhibited, and input gates to all eight stretchers are closed, 3 μ s after receipt of the validation pulse. The wide allowance of $\pm 3 \mu$ s on pulse-arrival time reduces the timing problems when complex pulse processing is done before the pulses are fed to the stretcher. (In most applications fast coincidence gating is done before the signals reach the analog multiplexer.)

After a further delay (D3) of 2 μ s, a 2- μ s pulse is generated whose amplitude is proportional to the output level of the first stretcher. This pulse can be fed to any external ADC. An ADC BUSY signal from the external ADC should then rise, and fall again only when the ADC has finished its conversion cycle. The trailing edge of the ADC BUSY retriggers delay D3, resulting in an output pulse whose amplitude is proportional to the level held by the second stretcher, and so on.

After stretcher N has been sampled, the general CLEAR signal is produced. The number of stretchers, N, to be sampled is selected between 1 and 8 by a front panel switch.

If the ADC BUSY signal should be present when the input signals arrive initially, the first output pulse to the ADC would occur only after the ADC BUSY signal returns to zero.

The "tree" decoder circuit (fig. 1) normally has all eight outputs at a slightly negative voltage level. When the 2- μ s strobe pulse reaches it, that output selected by the 3-bit scaler rises to +10 V. This has the effect of opening the diode gate from the corresponding stretcher for 2 μ s, thus providing a pulse of that width, and of amplitude proportional to the output voltage of the stretcher. An integrating time constant of 0.2 μ s, precedes a white emitter follower which can drive a 120 Ω cable to an ADC. (See fig. 4)

If no response were obtained from the ADC, the general CLEAR pulse would be generated after a delay of 10 milliseconds.

For simplicity in circuitry, the multiplex readout selects each stretcher in turn, and a 3-bit parallel digital code is provided to positively identify the stretcher number.

These instruments have been successfully used in multiparameter experiments having event rates as low as one per hour and as high as 2000 per second. In most cases, the digital codes from the ADC have been fed to computers which store the digital codes event by event.

on magnetic tape while simultaneously providing a CRT display of selected interesting regions of the spectrum.

FOOTNOTE AND REFERENCES

* This work was carried out as part of the research program of the Nuclear Chemistry Division of the Lawrence Radiation Laboratory, University of California, which is supported by U. S. Atomic Energy Commission Contract W-7405-eng-48.

1. L. B. Robinson, F. Gin, and F. S. Goulding, A High-Speed 4096-Channel Analogue-to-Digital Converter for Pulse Height Analysis, Nuclear Instruments & Methods 62 (1968) 237.

FIGURE CAPTIONS

Fig. 1. Block diagram of analog store and multiplexer. Input signals to the analog stretchers are accompanied by a "coincidence" or (validation) pulse, which causes input gates to close and transmits a pulse corresponding to the voltage on the first stretcher to an external ADC. When the ADC BUSY signal rises and then falls again, the second level is transmitted.

Fig. 2. Schematic diagram of stretcher circuit.

Fig. 3. Block diagram of typical interconnections for a multiparameter pulse-height experiment.

Fig. 4. Analog multiplex circuit details. Use of pairs of diodes carrying equal currents minimizes thermal base-line drift.

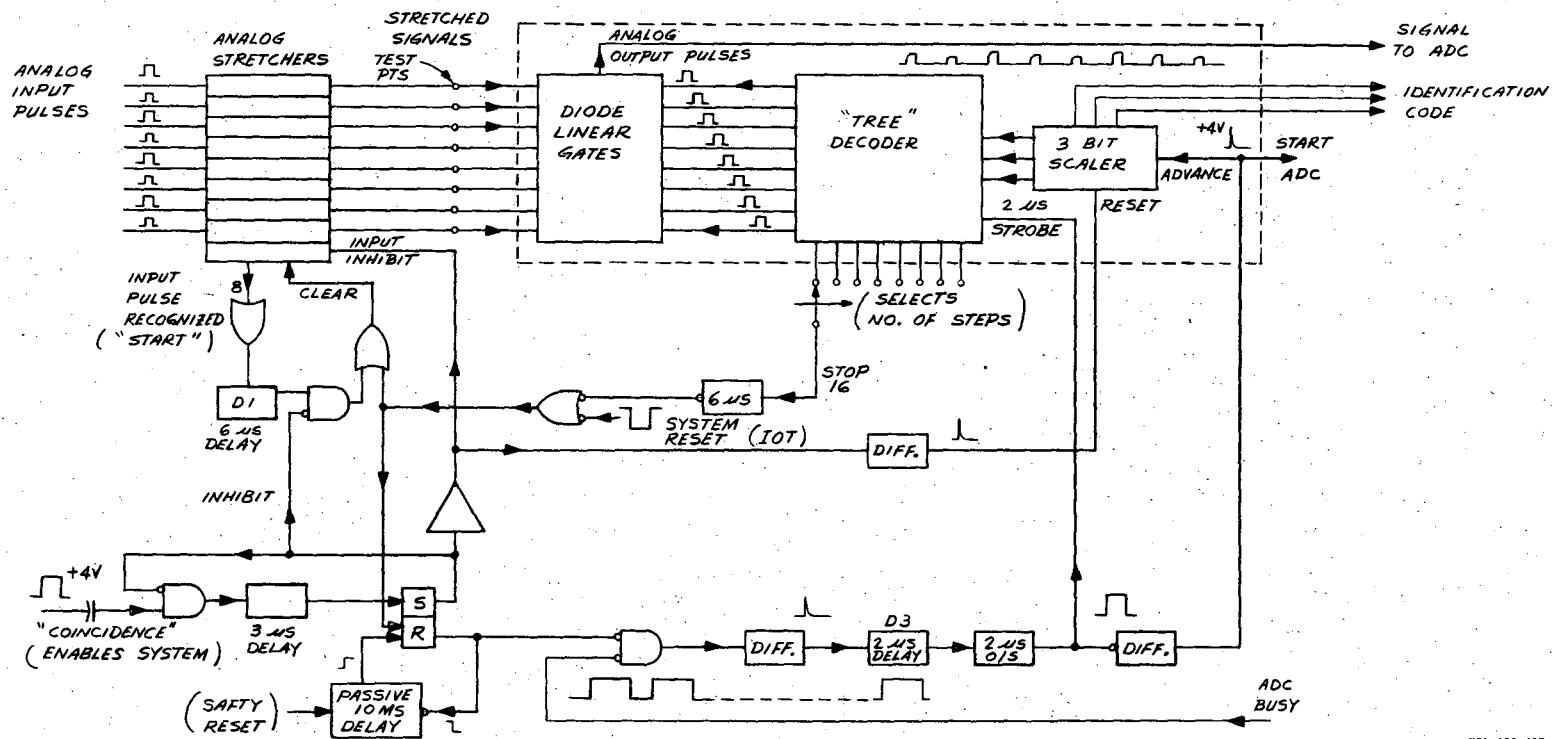

Fig. 1. Block diagram of analog store and multiplexer.

XBL 695-487

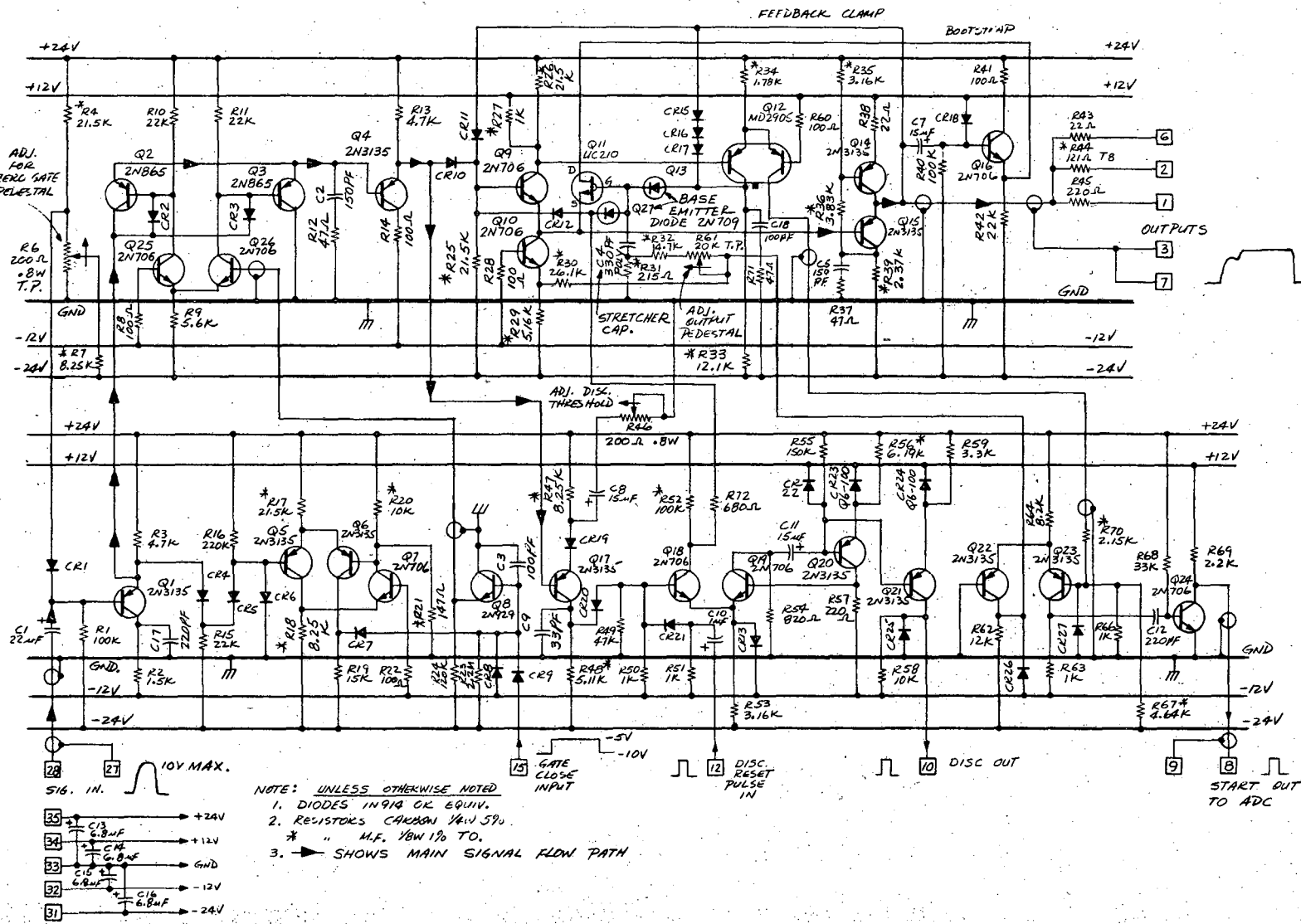
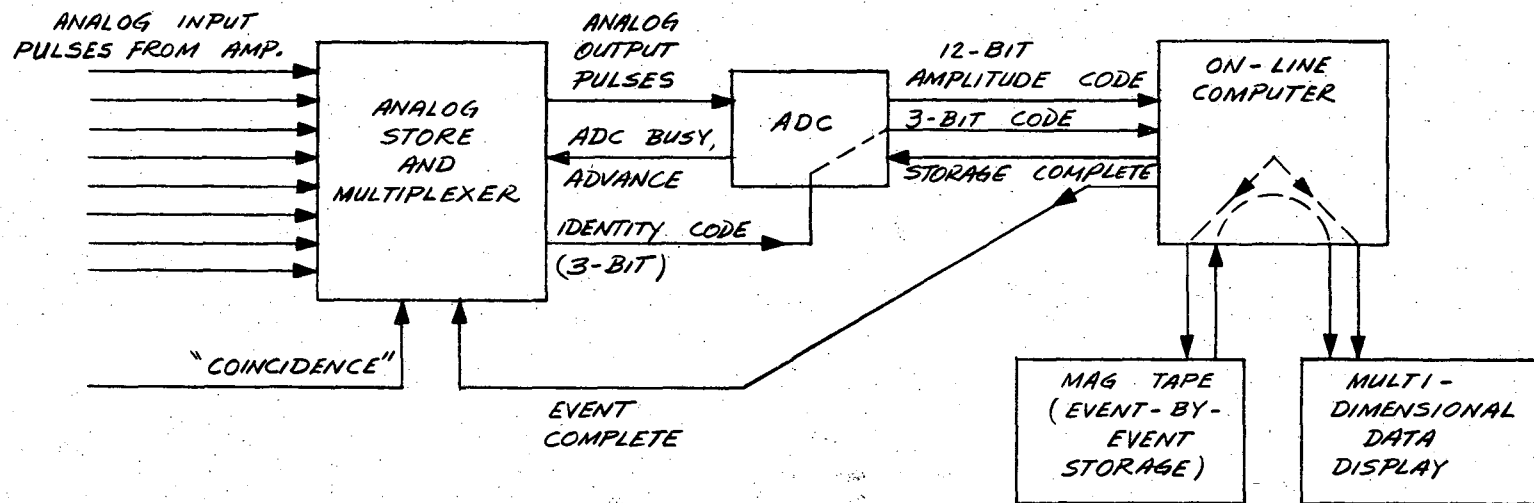

Fig. 2. Schematic diagram of stretcher circuit



XBL 695-488

Fig. 3. Block diagram of typical interconnections for a multiparameter pulse-height experiment.

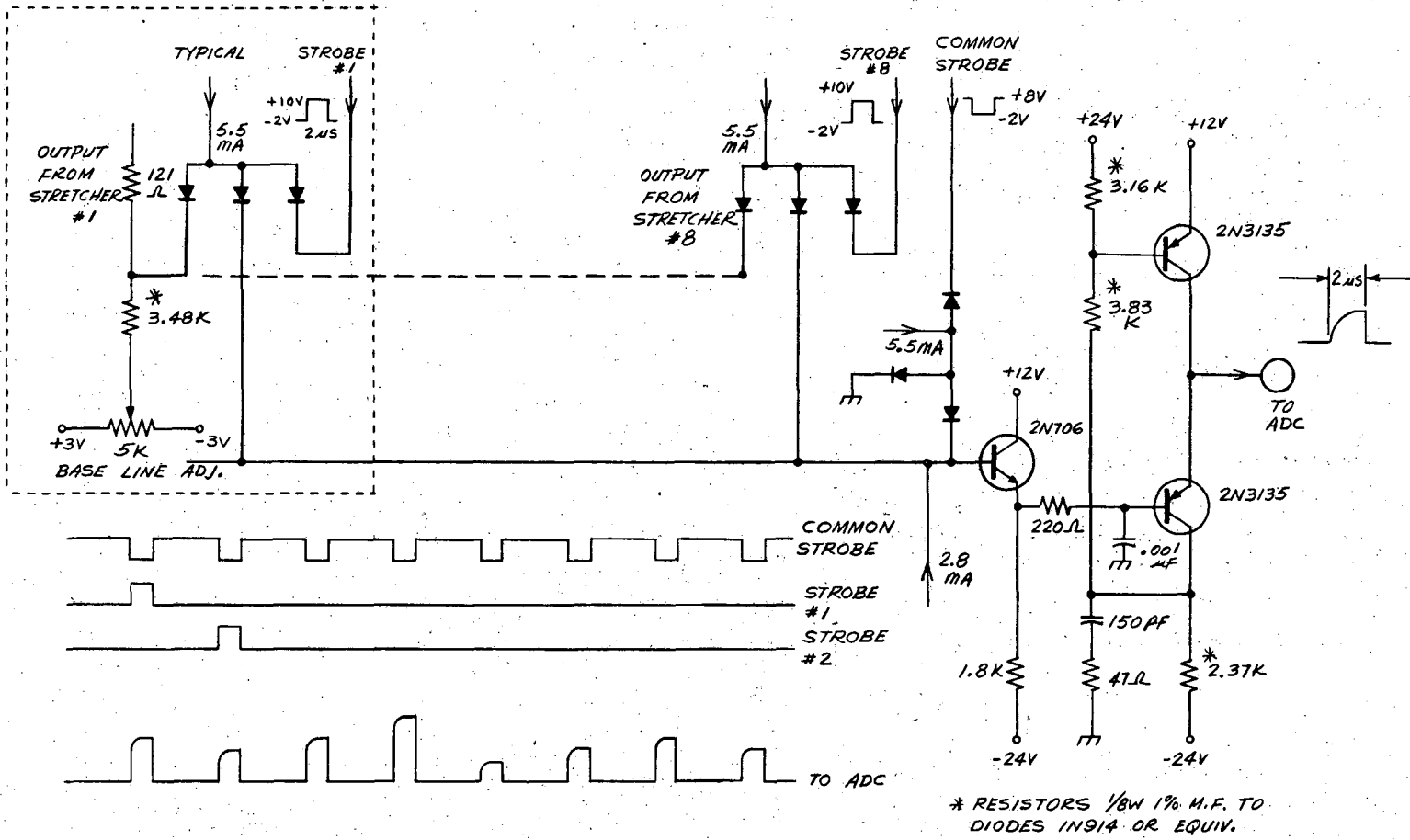

Fig. 4. Analog multiplex circuit details.

LEGAL NOTICE

This report was prepared as an account of Government sponsored work. Neither the United States, nor the Commission, nor any person acting on behalf of the Commission:

- A. Makes any warranty or representation, expressed or implied, with respect to the accuracy, completeness, or usefulness of the information contained in this report, or that the use of any information, apparatus, method, or process disclosed in this report may not infringe privately owned rights; or*
- B. Assumes any liabilities with respect to the use of, or for damages resulting from the use of any information, apparatus, method, or process disclosed in this report.*

As used in the above, "person acting on behalf of the Commission" includes any employee or contractor of the Commission, or employee of such contractor, to the extent that such employee or contractor of the Commission, or employee of such contractor prepares, disseminates, or provides access to, any information pursuant to his employment or contract with the Commission, or his employment with such contractor.

TECHNICAL INFORMATION DIVISION
LAWRENCE RADIATION LABORATORY
UNIVERSITY OF CALIFORNIA
BERKELEY, CALIFORNIA 94720