

Lawrence Berkeley National Laboratory

Recent Work

Title

THE BERKELEY HEW ELEMENT PROGRAM

Permalink

<https://escholarship.org/uc/item/1wm8j9db>

Author

Ghiorso, Albert.

Publication Date

1975-09-01

0 0 0 4 4 0 4 1 6 5
Presented at the International School Seminar
on Reactions of Heavy Ions with Nuclei and
Synthesis of New Elements, Dubna, Moscow,
USSR, September 23 - October 4, 1975

LBL-4346
c.1

THE BERKELEY NEW ELEMENT PROGRAM

Albert Ghiorso

September 1975

Prepared for the U. S. Energy Research and
Development Administration under Contract W-7405-ENG-48

For Reference

Not to be taken from this room

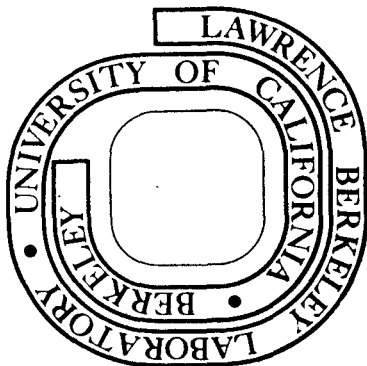

LBL-4346
c.1

DISCLAIMER

This document was prepared as an account of work sponsored by the United States Government. While this document is believed to contain correct information, neither the United States Government nor any agency thereof, nor the Regents of the University of California, nor any of their employees, makes any warranty, express or implied, or assumes any legal responsibility for the accuracy, completeness, or usefulness of any information, apparatus, product, or process disclosed, or represents that its use would not infringe privately owned rights. Reference herein to any specific commercial product, process, or service by its trade name, trademark, manufacturer, or otherwise, does not necessarily constitute or imply its endorsement, recommendation, or favoring by the United States Government or any agency thereof, or the Regents of the University of California. The views and opinions of authors expressed herein do not necessarily state or reflect those of the United States Government or any agency thereof or the Regents of the University of California.

THE BERKELEY NEW ELEMENT PROGRAM*

Albert Ghiorso

Lawrence Berkeley Laboratory
University of California
Berkeley, California 94720

Unfortunately I will not be able to report a great deal of progress in the new element program at Berkeley. The SuperHILAC is still deep in the throes of debugging (it is a very complicated accelerator!) and we have not been able to devote a great deal of bombardment time to this program nor to any other. I will review the work done with element 106 last year and will discuss a new experiment which bears upon the properties of the isotope of mass 260 with atomic number 104.

Element 106

My colleagues in this work are J. M. Nitschke, J. R. Alonso, C. T. Alonso, M. Nurmia, G. T. Seaborg, of the Lawrence Berkeley Laboratory and E. K. Hulet and R. W. Lougheed of the Lawrence Livermore Laboratory. We have now completed our analysis of all of the data obtained about one year ago in bombardments of ^{249}Cf with ^{18}O ions. An initial paper was published in Physical Review Letters^{/1/} which described the discovery of the nuclide $^{263}\text{106}$ and we are just now completing a more extensive paper to be sent to Physical Review.

*This work done under the auspices of the U. S. Energy Research and Development Administration.

At Berkeley, as you know, we prefer to identify a new element in an unambiguous way by using alpha particle emitters whenever this is possible. The positive identification of atomic number can be obtained either by the elegant method of Bemis et al^{/2/} in which daughter K x-rays are observed in coincidence with alpha particles or by the establishment of a clear genetic link between an alpha-emitting isotope of the new element and a previously identified alpha-emitting daughter. The latter method was used very successfully in the Berkeley discoveries of isotopes of elements 104 and 105^{/3/} and is superior to the former method in that it is more sensitive by almost an order of magnitude. In the case of element 106 we have carried this method one step further by demonstrating a link to the granddaughter as well as the daughter.

The reactions that we used were:

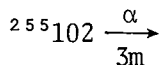
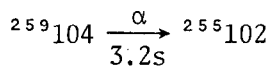
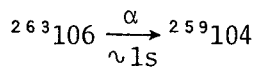
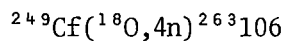

Before the experiment the reaction cross section was calculated^{/4/} to be 0.2 nanobarns at a peak energy of 95 MeV. This cross section is 35 times smaller than that available for the production of the alpha-emitting isotope, ²⁶⁰105, which we discovered in 1970. As a consequence it was necessary that special pains should be taken to eliminate or reduce effects which would cloud our identification of the predicted ~ 1-sec alpha-emitting ²⁶³106.

One of the most critical aspects of the experiment concerned the californium target. The target and its backing had to be ultrapure because tiny amounts of lead, bismuth, or mercury can produce interfering alpha-emitting activities when bombarded by ¹⁸O ions. The target had to withstand intense beam currents to make the experiment feasible in a reasonable bombardment time. Though beryllium had been proven by us previously to be much the best substrate material from the

standpoint of target cooling we were not able to use it in this experiment. The reason was that we had found that bombardment of Be by light ions produced copious quantities of 0.7-sec ^8Li . This nuclide becomes a source of a continuous background of high-energy alpha particles, presumably from the broad 2^+ and 4^+ states in ^8Be that are fed by high-energy β -decay from ^8Li . Indeed it was this particular background which had obscured our earliest attempts to identify $^{263}106$ unambiguously a few years ago.

The method that we chose to produce the californium target was the vaporization of CfF_3 onto a thin, heated, ultrapure aluminum foil (2.7 mg/cm^2). Fortunately Hulet and Loughheed found that the fluoride is reduced to the metal by the aluminum at the interface. This process seems to serve as a bonding agent for the bulk of the target which is largely CfF_3 ; these targets (several were made) were found to be very adherent. The final target used for most of the bombardments contained 259 micrograms of ^{249}Cf and had a surface density of $830 \text{ micrograms/cm}^2$. To prevent any "knockover" by the beam a coating of aluminum, $30 \text{ micrograms/cm}^2$, was vaporized over the target. The target was almost free of Pb impurity but we could still detect weak peaks at 8.81 MeV from ^{214}At and at 8.675 MeV from ^{223}Th . This calculates out to be about 5 ppm of Pb.

The target chamber was designed for maximum cooling and protection of the target during irradiation and for efficient transport of the recoil atoms from the target to the counting chamber. A schematic diagram is shown in Fig. 1. The ^{18}O beam passes through two windows of 3.5 mg/cm^2 Al foil before entering the target and then emerges through a set of two more windows of 3.5 mg/cm^2 Al and 2.4 mg/cm^2 Be, in that order.

The target and windows were mostly cooled by swiftly flowing helium gas at a temperature of -50°C . In addition, the beam was wobbled electromagnetically at 840 Hz to distribute the heating more evenly and its intensity was limited to 4×10^{12} ions/sec. As a further precaution we monitored the temperature by measuring the infrared radiation from the target through the use of thermistors at an angle of 30° to the beam.

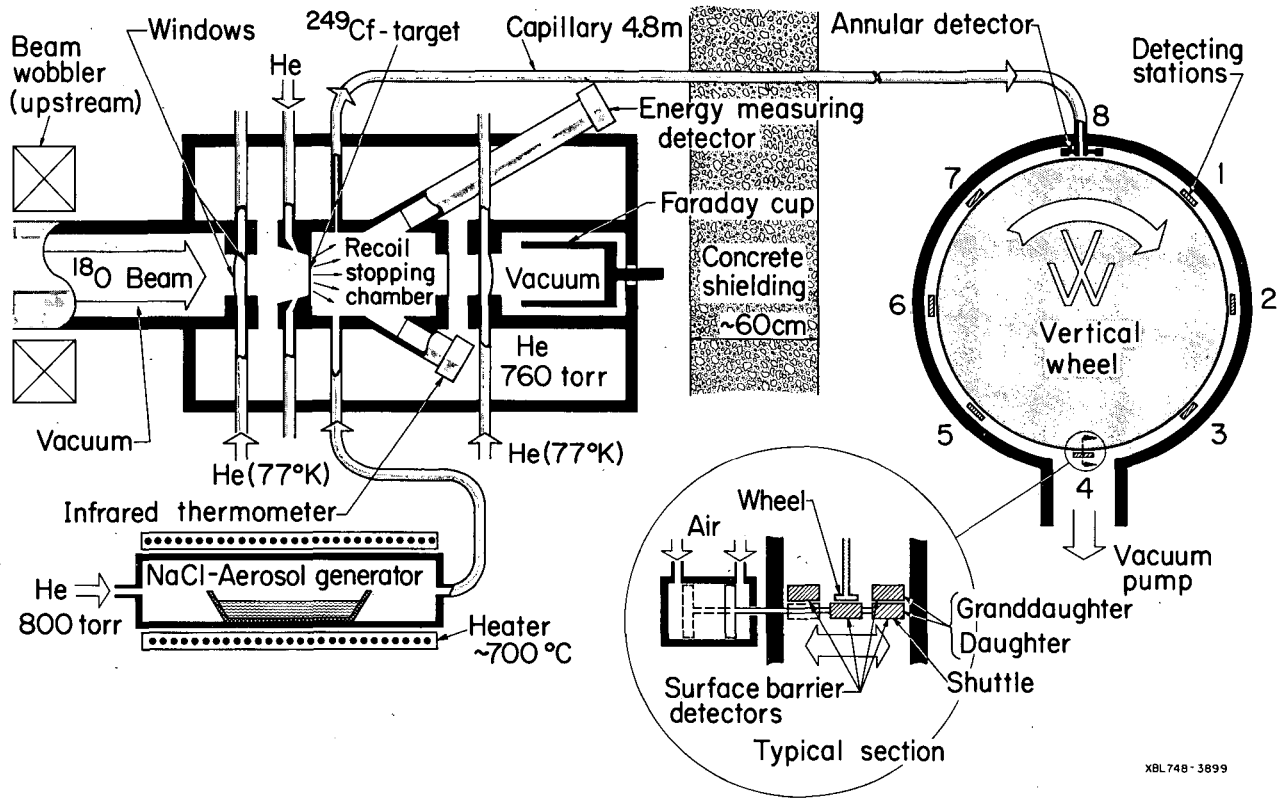

XBL 748 - 3899

Fig. 1

The energy of the ion beam was measured in various ways by means of solid state detectors. The energy after the target was typically 94.9 MeV with a spread of 4 MeV, although in later phases of the experiment this was varied above and below this value to obtain a rough excitation function.

In our old experiments we had housed our counting system adjacent to the target chamber in order to get efficient transfer of the recoils via our He gas jet technique. This made it necessary to gate off the detectors while the beam pulse was on to eliminate the high energy pulses produced by fast-neutron nuclear reactions in the detector silicon. In addition to this problem we had found that intense fast-neutron fluxes caused the detectors to gradually deteriorate.

To overcome this problem we have developed a very efficient method that can withstand the intense beams and transport the activities long distances in a very short time. By flowing 40 cc/sec of helium gas containing aerosols of pure NaCl through the recoil chamber, the recoiling activities are swept out and carried a distance of 4.8 meters in 0.1 seconds through a teflon capillary tube with an inside diameter of 0.9 mm. The exact mechanism is not yet understood for the attachment of the recoil products to the aerosols. The aerosols are produced in an oven at 600°C and a scanning electron microscope picture (magnification- 10^4) of a deposit made for 120 seconds is shown in Fig. 2. The particles are in the range from 0.1 to 1.0 microns.

The aerosols travel from the production volume at an atmospheric pressure of helium to the counting chamber at about 0.3 torr where they impact in a very small area onto a vertical wheel as shown in Fig. 1. The wheel is digitally rotated upon command from a PDP-9 computer. For this experiment we programmed the wheel to rotate 45° in 0.1 seconds and to remain stationary at each 45° station for 0.9 seconds during which time a new aerosol deposit was collected at the 0° position where the end of the capillary was located. To avoid accumulating too much salt at each of the eight positions, the wheel was stepped 1.5° every thirty minutes to expose a clean area on the wheel periphery.

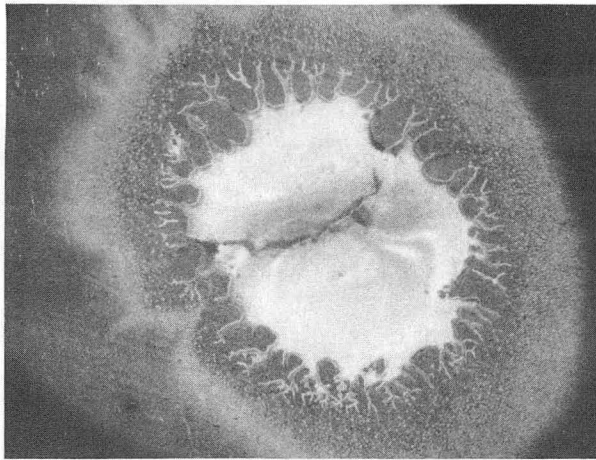

} × 30
↔ 1 mm

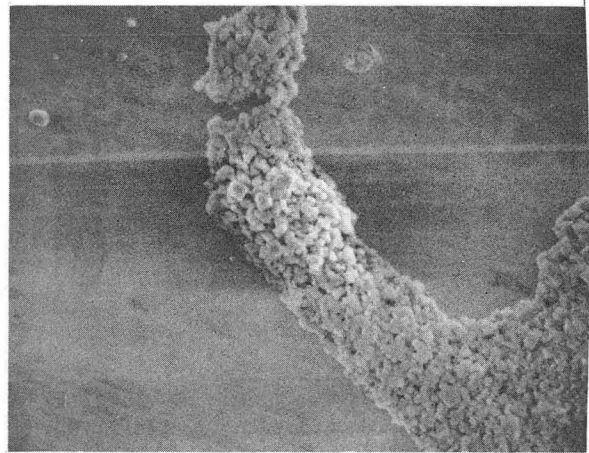

× 2000 }
↔ 10 μ }

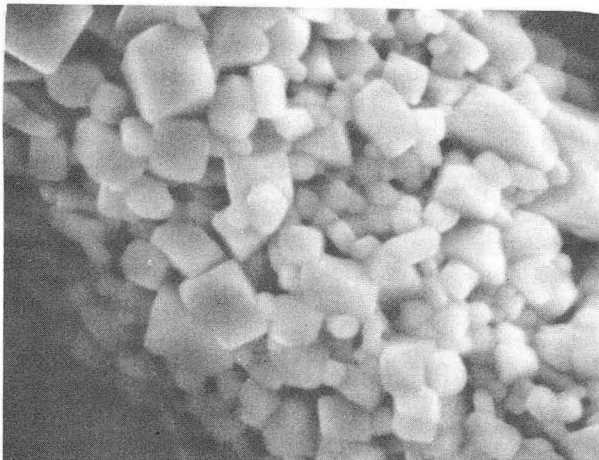

} × 10000
↔ 1 μ

XBB 758-6490

Fig. 2

At each station the alpha activity was measured by a Si(Au) surface barrier detector and thus we observed alpha decay as a function of time for seven deposits simultaneously. An annular detector was used at the 0° position some of the time but unfortunately problems with splashback of the NaCl limited the life of these detectors so that not much data were obtained from this position. The geometry of each of the seven wheel detectors was 38%.

The signals from each of the station detectors were separately amplified and passed through a summing amplifier. This amplifier's output was digitized and passed to the computer along with signals to identify the detector and the time when each event occurred via a CAMAC interface. Many more than seven detectors were involved, however, because we used a system of shuttled detectors in order to observe daughter and granddaughter decays and thus at each of the seven stations there were four detectors.

During the decay of the mother-106 atoms on the wheel rim, daughter atoms of $^{259}\text{104}$ could recoil into the solid angle subtended by the wheel detector 38% of the time. To observe the decay of those daughter-104 atoms that had alpha-recoiled away from the rim to the adjacent crystals we regularly shuttled the wheel detectors away from the wheel every six seconds and replaced them with a new set of detectors that continued to measure the activities on the wheel rim. The shuttled detector was moved to a position next to a similar detector so that together they could observe possible daughter-104 alpha decays. In the event that such a decay was observed, the shuttled detector was not returned to the wheel until 600 seconds had passed in order to observe possible alpha decay from a granddaughter-102 atom.

A total of ten separate accelerator runs were made with an average beam current of about 0.4 particle microamperes of ^{18}O for about 45 particle microamperehours. Rough analyses of the data were made on-line and a more thorough event-by-event analysis was carried out afterward on a CDC-7600 computer. Processing included spectrum adjustment for gain shifts according to internal alpha monitoring peaks, spectrum analysis for peak shape and peak identifica-

tion, time correlation studies between various energy peaks, and analysis of accidental data probabilities. A study was also made of the long, low energy tails of the long half-life Fm and Cf peaks in order to estimate the effective thickness of the salt deposits, this in order to calculate the efficiency of transferring the daughter-104 atoms after alpha recoil from the mother-106 atoms.

In order to prove a genetic relationship between the element-106 mother and its element-104 daughter we looked for time-correlated events in the alpha spectra. Thus we searched the data for a given time interval after each possible mother event for daughter events falling within a prescribed energy window with the stipulation that both events originated from the same spot on the wheel. The mother window was set from 8.5 to 10.0 MeV, the daughter window from 8.69 to 8.91 MeV (the $^{259}\text{104}$ peaks known from our previous work are 8.77 and 8.86 MeV), and the maximum time interval was set as 12 seconds (the half-life of $^{259}\text{104}$ is 3.2 seconds). The total counting rates were very low (1 count per 1000 seconds) so that two events in the high energy region within this time interval were likely to be genetically correlated. In order to be certain that the accidental coincidence rate was as low as predicted we also looked for correlations under the same stipulations but displaced in time such that the 12 second interval occurred between 60 and 72 seconds after each mother-106 event.

In Fig. 3a is shown a final singles spectrum of the on-wheel alpha events summed over all the runs. All the major peaks have been identified with well-known nuclides. The peaks at 9.06 ± 0.04 MeV and $9.25 \pm .05$ MeV are attributed to the isotope $^{263}\text{106}$. In Fig. 3b is shown the alpha spectrum of all events found in the interval 0-12 seconds preceding a $^{259}\text{104}$ alpha decay in the energy window between 8.69 and 8.91 MeV. Clearly the ^{256}No and ^{257}No peaks are accidentals because of their relatively high counting rates. There were fifteen correlated events at 9.06 MeV and one correlation at 9.25 MeV. A similar spectrum for the 50 - 62 seconds before the same $^{259}\text{104}$ decays is shown in Fig. 3c. The single accidental correlation in the element-106 energy region is consistent with a calculation applying Poisson's distribution theory.

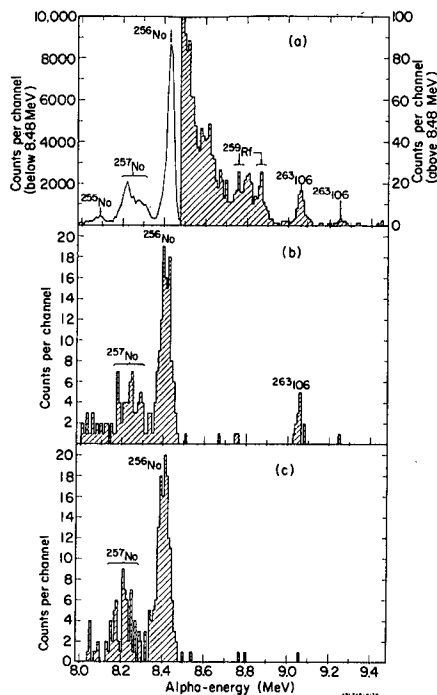

Fig. 3

Figure 4 shows the combined spectrum from all off-wheel crystals. Since all the activities in this spectrum arise from the decay of daughter nuclei, it is instructive to identify not only the peaks, but also the decay sequence which brought these activities to the off-wheel position. Another useful datum is the distribution of the daughter activities at different stations, as this indicates the half-life of the mother decay responsible for the recoil of the daughter off of the wheel. In order of ascending energy, there is

- (1) ^{246}Cf (6.76 MeV), evenly distributed at all stations implying a long parent half-life (^{250}Fm);
- (2) A shoulder attributable to ^{253}Fm via ^{257}No , and/or ^{251}Fm via ^{255}No ;
- (3) ^{252}Fm (7.05 MeV), distributed with a 3 second mother half-life (^{256}No);
- (4) ^{254}Fm (7.22 MeV), probably recoiling from 10-min ^{254}Md after electron-capture decay;
- (5) ^{250}Fm (7.44 MeV), distributed to the stations according to a 2.0 ± 0.2 sec mother half-life.

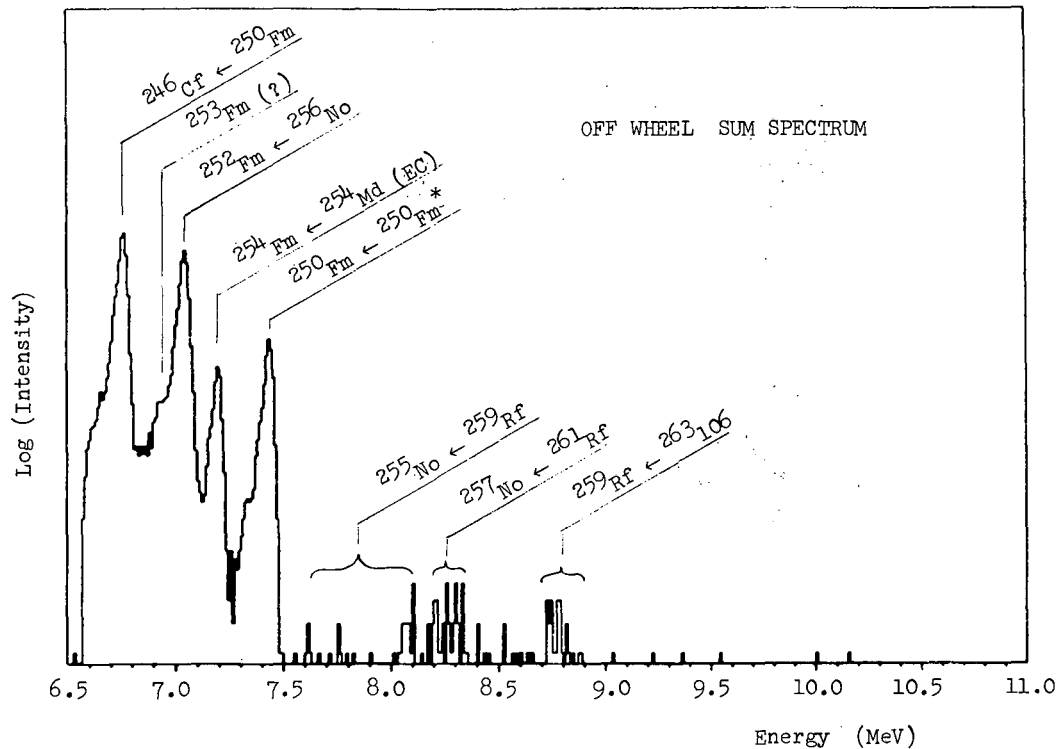

Fig. 4

XBL 759-8192

This last effect has been seen previously^{/5/} and has been assigned to an isomeric state in ^{250}Fm .

The small groups at higher energies correspond to ^{255}No , ^{257}No , and ^{259}Rf . Although statistics are weak, the distribution of the first and the last indicate substantially shorter mother half-lives than for the ^{257}No group, thus providing consistency with the assignments of ^{259}Rf , ^{261}Rf , and $^{263}106$, respectively, as the mother nuclei. The 50% e.c.-branching of ^{255}No ,^{/6/} accounts for the relative weakness of this group compared to the on-wheel $^{259}\text{Rf}/^{263}106$ ratio. Note also that ^{261}Rf is obscured in the on-wheel spectra by the ^{257}No lines which are produced directly with high yield. Note that although activities can be transferred by isomeric transitions as well as by alpha decay, the chances that the ^{259}Rf activities were deposited by any other mechanism than the alpha decay of $^{263}106$ are quite remote since the number of direct alpha-alpha correlations observed on-wheel predicts that the number of ^{259}Rf atoms we should see off-wheel is well within statistics of what we actually observed.

We believe that these experiments unambiguously assign the new alpha activities to $^{263}106$. The alpha-alpha on-wheel time correlations give direct evidence for our hypothesis and the off-wheel alpha-recoil spectra plus the time-correlated daughter-104 with granddaughter-102 events supply strong supporting evidence. Additional evidence was provided by a crude excitation function peaking in the region of 95 MeV with a cross section of about 0.2 nb. The half-life of the new activity was found to be 0.9 ± 0.2 sec (see Fig. 5). No prominent spontaneous fission branching decay was observed so presumably this is the alpha half-life of $^{263}106$.

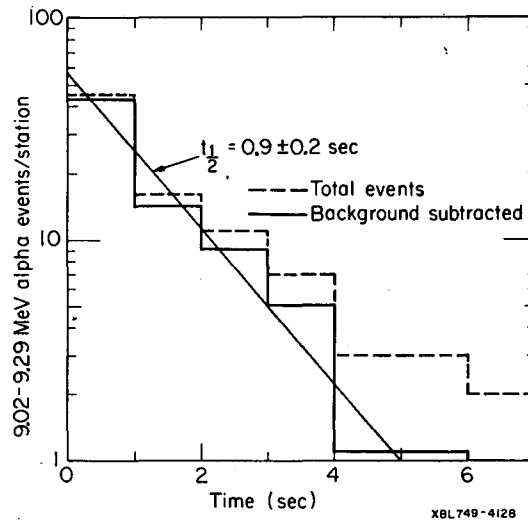

Fig. 5

The position of the half-life for $^{263}106$ in a plot of alpha decay half-life vs. neutron number (see Fig. 6) fits into the systematics very well. Of course these data for atomic numbers 104 and 106 are for odd-neutron numbers, so the dramatic jump that exists in the element-104 data at $N=152$ could only be due to the odd neutron orbitals or to a contribution from the element-102 daughter; but on the other hand, nothing in these alpha decay data contradicts the possibility that the $N=152$ subshell still exists at atomic number 104. In fact, according to C. F. Tsang^{/7/} at Berkeley, these data can be taken to imply a strong indication that this is indeed the case.

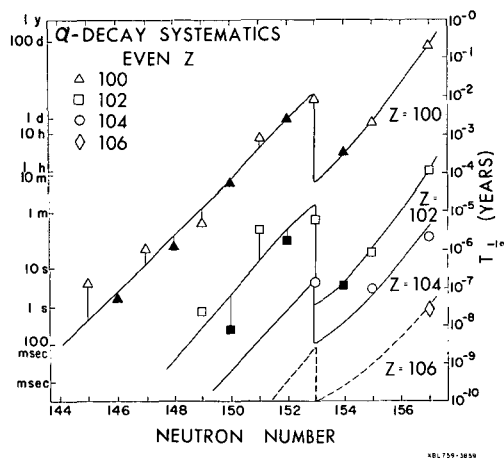

Fig. 6

It is also interesting to look at the systematics of spontaneous fission decay. In Fig. 7 is shown an updated version of my original systematics plot of 1959 in which I showed the relationships between half-life and neutron number. The nuclide ²⁵⁹Fm has recently been discovered and Ken Hulet will talk about that work in a later paper. The same hindrance factor from the even-even line observed for ²⁵⁷Fm is applied to ²⁵⁹Fm to extend the fermium line to 159 neutrons. The Dubna systematics for various nuclides are shown on the right.

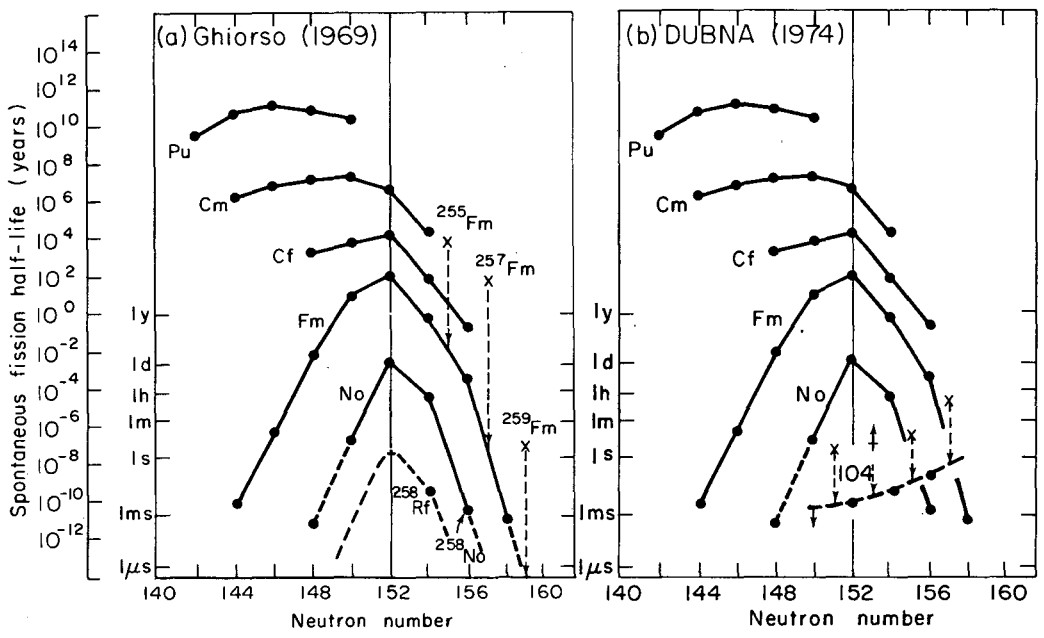

Fig. 7

Element 104

I will turn now to a recent result concerning the nuclide $^{260}104$ which bears on our friendly controversy with Dubna regarding the discovery of that element. Hopefully this material will shed some new light on the problem and lead to a solution.

Back in 1969 I reported on Berkeley attempts to confirm the Dubna discovery of a 0.1-sec SF activity as being due to $^{260}104$. The Dubna work came from the bombardment of ^{242}Pu by ^{22}Ne , whereas our experiments were made with lighter ions on heavier targets. We found that we could not produce the presumed $^{260}104$ isotope in bombardments of ^{246}Cm by ^{18}O , ^{248}Cm by ^{16}O , and ^{253}Es by ^{11}B . These experiments covered a range of half-lives down to milliseconds and yet we were not able to find the hypothesized spontaneous fission activity.

A few months ago my colleagues, M. Nurmi, P. Sommerville, K. Williams, K. Hulet and I performed an even more sensitive experiment by bombarding ^{249}Bk with ^{15}N ions. The reaction to make the SF activity is $^{249}\text{Bk}(^{15}\text{N},4n)^{260}104$. The calculated cross section is 14 nanobarns at a bombardment energy of 82 MeV. This calculation should be fairly accurate since we have a nearby experimental "anchor" point in the $^{249}\text{Cf}(^{15}\text{N},4n)^{260}105$ reaction which we measured some years ago.

Two experiments were performed using the rotating drum device shown in Fig. 8. Mica fission track detectors were used as in the past. In one experiment the drum revolved with a peripheral reciprocal speed of 4.5 ms/mm and in the other at 2.4 ms/mm. The ^{249}Bk target had a surface density of 1.0 mg/cm². The beam energy of the ^{15}N impinging on the target was 82 MeV in both experiments. In the first experiment we used 0.8 microamperehours and in the second 2.0, both measured as $^{15}\text{N}^{7+}$.

In the first experiment we should have observed about 80 tracks of $^{260}104$ if its half-life is in the 100 ms range, and in the second we should have observed about 200. Thus we should have easily seen such an activity since the tracks would have been bunched into the first two or three mica plates. In actuality we found only about 5 tracks per mica plate uniformly spread through the 14 plates.

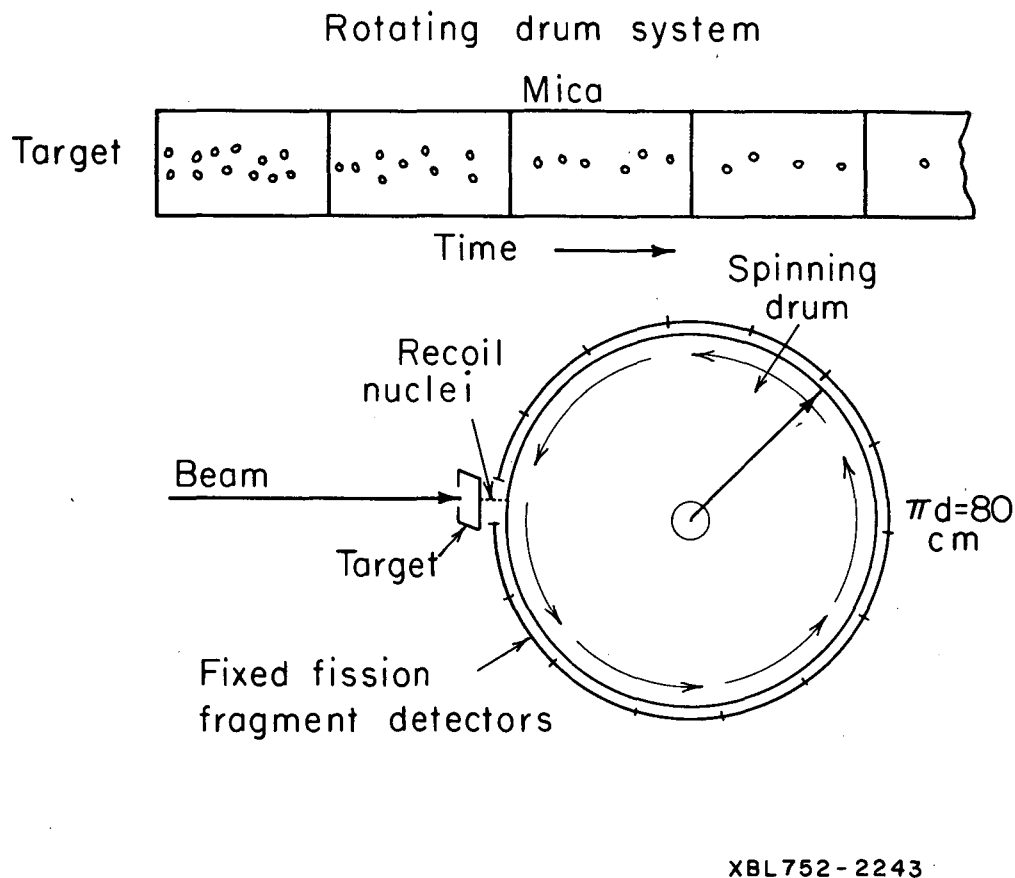

Fig. 8

These are undoubtedly due to the nuclide 2.7-hr ^{256}Fm . We have set conservative limits for the production of an 0.1-sec $^{260}\text{104}$ by this reaction at < 1.7 nanobarns in the first experiment and < 0.7 nanobarns in the second. We conclude that the half-life of this nuclide is not 0.1 sec.

Since our prediction of the half-life of $^{260}\text{104}$ for SF decay is in the microsecond or even sub-microsecond region we have turned to other methods to find this nuclide. One method that we are working on utilizes a gas scintillation counter and, theoretically, is capable of measurements into the nanosecond region. Unfortunately the ion beam produces some severe experimental problems so that we cannot yet report success. The $^{260}\text{104}$ half-life problem, however, is so interesting that we intend to persevere until we do reach our goal.

REFERENCES

1. A. Ghiorso, J. M. Nitschke, J. R. Alonso, C. T. Alonso, M. Nurmia, G. T. Seaborg, E. K. Hulet and R. W. Lougheed, *Phys. Rev. Lett.* 33, 1490 (1974).
2. P. F. Dittner, C. E. Bemis, D. C. Hensley, R. J. Silva and C. D. Goodman, *Phys. Rev. Lett.* 26, 1037 (1971); C. E. Bemis, R. J. Silva, D. C. Hensley, O. L. Keller, J. Tarrant, L. Hunt, P. F. Dittner, R. Hahn and C. D. Goodman, *Phys. Rev. Lett.* 31, 647 (1973).
3. A. Ghiorso, M. Nurmia, J. Harris, K. Eskola and P. Eskola, *Phys. Rev. Lett.* 22, 1317 (1969); A. Ghiorso, M. Nurmia, K. Eskola, J. Harris and P. Eskola, *Phys. Rev. Lett.* 24, 1498 (1970).
4. J. R. Alonso, in *Gmelin Handbuch der Anorganischen Chemie, Ergänzungswerk* (Springer, Berlin, 1974) Vol. 7b, Part A1, II, p. 28.
5. A. Ghiorso, *Welch Foundation Conferences on Chemical Research*. XIII. The Transuranium Elements - The Mendeleev Centennial, Houston, Texas (1969).
6. A. Ghiorso et al, unpublished data, 1970. This value has been confirmed by Bemis et al at ORNL and will be published soon.
7. C. F. Tsang, Annual Report Nuclear Chemistry, Lawrence Berkeley Laboratory UCRL-20426 (1970), p. 133.

LEGAL NOTICE

This report was prepared as an account of work sponsored by the United States Government. Neither the United States nor the United States Energy Research and Development Administration, nor any of their employees, nor any of their contractors, subcontractors, or their employees, makes any warranty, express or implied, or assumes any legal liability or responsibility for the accuracy, completeness or usefulness of any information, apparatus, product or process disclosed, or represents that its use would not infringe privately owned rights.

TECHNICAL INFORMATION DIVISION
LAWRENCE BERKELEY LABORATORY
UNIVERSITY OF CALIFORNIA
BERKELEY, CALIFORNIA 94720