

# UC Berkeley

## Course Notes

### Title

Fundamentals of Traffic Engineering - 16th Edition

### Permalink

<https://escholarship.org/uc/item/1vp7t2dp>

### ISBN

0192-5911

### Authors

Homburger, Wolfgang S.

Hall, Jerome W.

Reilly, William R.

et al.

### Publication Date

2007-02-01

Institute of Transportation Studies  
University of California, Berkeley  
[www.its.berkeley.edu/fundamentals/](http://www.its.berkeley.edu/fundamentals/)

## **Fundamentals of Traffic Engineering**

16TH EDITION

COURSE NOTES  
UCB-ITS-CN-07-1  
February 2007  
ISSN 0192-5911



# **Fundamentals of Traffic Engineering**

16TH EDITION

**Wolfgang S. Homburger**

Research Engineer Emeritus, Institute of Transportation Studies  
University of California, Berkeley, CA

**Jerome W. Hall**

Professor of Civil Engineering  
University of New Mexico, Albuquerque, NM

**William R. Reilly**

Transportation Consultant  
Tucson, AZ

**Edward C. Sullivan**

Professor of Civil & Environmental Engineering  
California State Polytechnic University, San Luis Obispo, CA

With contributions by guest authors of the chapters indicated:

Chapter 21: Michelle DeRobertis, P.E., Consulting Traffic Engineer, Oakland, CA

Appendix B: Loretta Hall, Freelance Technical Writer, Albuquerque, NM

Chapter 26: John J. Logan, P.E., Principal, JL & Associates, Seattle, WA

Chapter 20: Matthew Ridgway, Principal, Fehr & Peers, San Francisco, CA

Chapter 28: Vernon H. Waight, P.E., Caltrans (Retired), San Francisco, CA

## Preface and Acknowledgments

This syllabus serves as an introduction to the field of traffic engineering to professionals who are being assigned traffic engineering tasks for the first time and as a source of recent information for those already in the field. It is designed mainly for one-week short courses, but past editions have also seen increasing use in university engineering courses and for individual study.

Traffic engineering is an ever-changing profession. New standards, guidelines, and basic texts rapidly replace older reference volumes. This 16<sup>th</sup> edition again includes new and revised material needed by students and practicing engineers. We have recognized the growing interest in non-motorized transportation modes by adding a new chapter on Bicycle Characteristics and Facilities and vastly expanding the chapter on Pedestrian Mobility and have also added a chapter on Work Zone Traffic Control. We have invited guest contributors to write these chapters and others to revise other material. On the other hand we have deleted the chapter on Mass Transit Systems, retaining a few items of specific concern to the traffic engineer elsewhere in the syllabus.

Even so, these notes cannot cover all the material required for even a basic understanding of traffic engineering; the student will also need access to the latest editions of such standard references as ITE's *Traffic Engineering Handbook* and the companion *Transportation Planning Handbook*, FHWA's *Manual on Uniform Traffic Control Devices*, TRB's *Highway Capacity Manual*, ITE's *Manual of Transportation Engineering Studies*, and AASHTO's *Policy on Geometric Design of Highways and Streets*. Many of the references listed at the end of each chapter also offer more detailed information.

We again use the International System of Units (metric system). See page vi.

We wish to thank the guest authors listed on the preceding page who have made valuable contributions: Michelle deRobertis for creating Chapter 21, Loretta Hall for the Appendix on Technical Communications (plus her editorial work to convert endnotes into reference lists), John Logan for writing Chapter 26, Matthew Ridgway for revising and expanding Chapter 20, and Vernon Waight for updating Chapter 28. We are also grateful to Diana Gould Wells for her valuable contribution to Chapters 29 and 30. Thanks are also expressed to Michael Ereti, Michael Hendrix, and Jason Simmers, all of Tucson, for providing draft materials.

Valuable publication assistance was given by Steven Campbell, Assistant Director, and Phyllis Orrick, Senior Publications Manager of the Institute of Transportation Studies at the University of California, Berkeley. Last, but certainly not least, we appreciate the work of Judy Greene-Janse, who has given this edition a new, professional-looking design and cover.

## Table of Contents

iv	Preface
1	Introduction
2	Transportation Characteristics
3	Human and Vehicle Characteristics
4	Traffic Stream Characteristics
5	Volume Studies and Characteristics
6	Spot Speed Studies
7	Travel Time and Delay Studies
8	Roadway and Intersection Capacity
9	Accidents and Safety
10	Parking Studies and Characteristics
11	Transportation Demand Studies
12	Transportation Planning
13	Introduction to Traffic Control Devices
14	Traffic Signs and Markings
15	Traffic Signals
16	Traffic Signal Control Systems
17	Geometric Design of Streets and Highways
18	Geometric Design of Intersections and Interchanges
19	Intersection Control
20	Pedestrian Mobility
21	Bicycle Characteristics and Facilities
22	Speed Zoning and Control
23	Curb Parking and Control
24	Major Street Operations
25	Freeway Operations
26	Work Zone Traffic Control
27	Off-Street Parking and Terminals
28	Roadway Lighting
29	Environmental Impact Studies
30	Air Pollution
31	Highway Traffic Noise
32	Energy Consumption in Transportation
33	Traffic Legislation
34	Traffic Management
35	Traffic Engineering Administration
A	Statistical Analysis
B	Technical Communications
	Index and Errata

## The International System of Units (SI)

In this syllabus, SI units are used predominantly. When material deals with or quotes legislation (e.g., speed limits, vehicle dimensions), SI units are also used, but U.S. customary units follow in square brackets. Some figures reproduced from other publications, if dimensioned in U.S. customary units, have not been changed except that a conversion table may have been added.

For those not familiar with the rules and conventions governing the use of SI units, we list those that primarily apply to traffic engineering and that we have attempted to follow in the syllabus.

- Base SI units are the meter (m) for *length*, the kilogram (kg) for *weight*, the second (s) for *time*, and the candela (cd) for *luminous intensity*\*. Special unofficial units are the liter ( $L = 10^6 \text{ mm}^3$ ) and the metric ton ( $t = 1000 \text{ kg}$ ); derived units are the newton ( $N = 1 \text{ kg} \cdot \text{m/s}^2$ ), the joule ( $J = N \cdot \text{m}$ ), and the pascal ( $\text{Pa} = 1 \text{ N/m}^2$ ).
- Decimal prefixes to the tertiary power of 10 are preferred. The most common prefixes are mega- for  $10^6$  times the base unit, kilo- for  $10^3$ , milli- for  $10^{-3}$ , and micro- for  $10^{-6}$  times the base unit, respectively. Others, e.g., centi- as in centimeters, are to be avoided.
- Products of two or more units are written with a dot above the line; e.g., veh • km for vehicle-kilometer.
- In SI notation, spaces replace commas to separate long strings of digits into groups of three; e.g. \$10 000. However, in the interest of clarity and to avoid breaking long digit strings at the end of lines, we retain commas to the left of, and omit spaces to the right of the decimal point.

The following table lists some U.S. conventional units of measurement used in traffic engineering, their approximate SI equivalents ("hard conversion") and their exact equivalents ("soft conversion"). The hard conversions shown in the table are *sometimes* used when converting U.S. conventional-unit standards; however, other rounding may occur. For example, speeds in mph are hard-converted to km/h by multiplying by 1.6, but the result may then be rounded either up or down to the nearest 5 km/h.

U.S. Customary Units	Metric Equivalent		U.S. Customary Units	Metric Equivalent	
	Hard	Soft		Hard	Soft
1 inch	25 mm	25.40 mm	1 inch <sup>3</sup>	16 mm <sup>3</sup>	16.387 mm <sup>3</sup>
1 foot	0.3 m	0.3048 m	1 foot <sup>3</sup>	0.028 m <sup>3</sup>	0.0283 m <sup>3</sup>
1 yard	0.9 m	0.9144 m	1 yard <sup>3</sup>	0.765 m <sup>3</sup>	0.76456 m <sup>3</sup>
1 mile	1.6 km	1.609 km	1 gallon (U.S.)	3.75 L	3.7854 L
1 inch <sup>2</sup>	650 mm <sup>2</sup>	645.15 mm <sup>2</sup>	1 pound	0.45 kg	0.4536 kg
1 foot <sup>2</sup>	0.09 m <sup>2</sup>	0.0929 m <sup>2</sup>	1 short ton	900 kg	907.18 kg
1 acre	0.4 ha	0.4047 ha	1 long ton	1000 kg	1016.06 kg
1 mile <sup>2</sup>	2.6 km <sup>2</sup>	2.5900 km <sup>2</sup>	1 pound force	4.45 N	4.44822 N
1 horsepower	0.75 kW	0.7457 kW	1 mi/gal (U.S.)	0.425 km/L	0.42514 km/L
1 BTU	1050 J	1055 J	1 BTU/mile	650 J/km	655.55 J/km
1 footcandle	10.75 lx	10.7639 lx	1 lbf/inch <sup>2</sup>	6900 Pa	6894.76 Pa

\* The three others are the ampere (*electric current*), kelvin (*temperature*), and mole (*amount of substance*).

## A. Definitions

- 1 **Transportation Engineering.** "The application of technology and scientific principles to the planning, functional design, operation and management of facilities for any mode of transportation in order to provide for the safe, rapid, comfortable, convenient, economical, and environmentally compatible movement of people and goods." (Ref. 1.)
- 2 **Traffic Engineering.** "That phase of transportation engineering which deals with the planning, geometric design and traffic operations of roads, streets and highways, their networks, terminals, abutting lands, and relationships with other modes of transportation." (Ref. 1.)

Professor W. R. Blunden\* restated this definition as follows: "Traffic engineering is the science of measuring traffic and travel, the study of basic laws relating to traffic flow and generation, and the application of this knowledge to the professional practice of planning, designing, and operating traffic systems to achieve safe and efficient movement of persons and goods." Each part of this definition is elaborated upon in B. 1 - 4 below.

- 3 **Travel and Traffic.** As used in the above definitions, *travel* refers to the demand for transportation of persons or goods between various origins and destinations; *traffic* refers to the actual movement of vehicles (motorized and nonmotorized) or pedestrians on a facility. However, this distinction does not apply when "travel" is used as part of such phrases as "travel time" or "travel speed" (see Chap. 7).

## B. Scope of Traffic Engineering

The practice of traffic engineering can be divided into five major functional areas:

- 1 **Studies of Traffic Characteristics.** ". . . the science of measuring traffic and travel, the study of basic laws relating to traffic flow and generation . . ." Traffic studies must be conducted to obtain data on transportation and traffic trends for entire regions and on traffic conditions at specific locations. The most common studies cover the following fields:
  - a. Vehicular and human factors.
  - b. Traffic flow rates (volumes), speed, travel time, and delay.
  - c. Traffic stream capacity and levels of service of streets and intersections.
  - d. Pedestrian flow patterns.
  - e. Travel patterns, trip generation factors, origins and destinations.
  - f. Demand and use of parking and truck loading facilities.
  - g. Mass transit performance and use.
  - h. Safety analysis.

---

\*Professor Emeritus of Traffic Engineering, University of New South Wales, Sydney, Australia; died 2003.



- 2 **Transportation Planning.** "... the application of this knowledge to ... planning ..."
- a. Continuing comprehensive transportation planning studies to guide the development of transportation facilities that will meet the goals and standards of the community, as well as the policies of the national and state governments.
  - b. Long-range plans for highway networks, mass transit systems, terminals, and off-street parking, based on the state, regional, or local transportation plan.
  - c. Plans for specific facility development, improvement, or redeployment.
  - d. Environmental impact studies of the long-range and specific effects of proposed projects.
  - e. Research into factors underlying transportation systems and the behavior of the users of these systems.
- 3 **Geometric Design.** "... the application of this knowledge to ... designing ..."
- a. Design of geometric features for new highways based on traffic engineering analyses.
  - b. Redesign of existing highways and intersections to increase capacity, the utilization of existing capacity, and safety.
  - c. Design of off-street parking and terminals.
  - d. Establishment of standards for subdivision designs, driveways, and access control.
- 4 **Traffic Operations and Control.** "... the application of this knowledge to ... operating traffic systems ..."
- Traffic operations are conducted through the authority of state laws and local ordinances, by application of traffic control devices, in accordance with accepted standards and warrants.
- a. *Laws and Ordinances.* As is the case for all aspects of human behavior, the behavior of drivers, bicyclists, and pedestrians can be controlled by government only to the extent that laws and ordinances provide for these controls and that the public is informed of the behavior expected of it and of the consequences if these regulations are violated.
  - b. *Control Devices.* These are the channels of communication between the traffic engineer, when exercising operations control functions, and the public using highways as drivers, bicyclists, or pedestrians.
  - c. *Standards and Warrants.* Effective traffic operational controls require that devices communicate their messages clearly and consistently. Standards and warrants have been developed, and are under continuous review, to promote uniformity of application of traffic controls.

Based on principles adopted through the regional planning process, the goal of traffic operations functions may include redirecting traffic demand through Transportation System Management (TSM), Traffic Demand Management (TDM), and Congestion Management System (CMS) methods as well as attempting to accommodate all demand in a safe and expeditious manner.

In addition, initiatives involving both the public and private sector are underway for research, development, demonstration, and implementation of advanced traffic control and communication strategies. A depiction of what systems of this type are likely to involve is shown in Fig. 1-1, which has been adapted from Ref. 2.

- 5 **Administration.** Executing traffic engineering tasks requires greater or lesser amounts of administration. Each general government - national, state, city, township, or county - assigns executive responsibilities through statutes or ordinances. Traffic engineering functions are assigned to a specific office or individual officer (e.g., director of public works). The following administrative tasks, among others, must be provided for:

- a. Organization of the office to carry out its duties.
- b. Day-by-day operation of the office.
- c. Maintenance of inventories of the transportation infrastructure and control devices.
- d. Contact with the public, elected officials, other agencies, etc.
- e. Administrative planning (e.g., budgeting, staffing needs, organizational structure).

### C. The Traffic Engineering Profession

The Institute of Transportation Engineers (ITE), founded in 1930 as the Institute of Traffic Engineers, is the professional society for transportation engineers. Its membership as of 2004 was over 16,000 in 90 countries. The Institute's aims include the advancement of transportation and traffic engineering, the fostering of education and professional improvement of its members, the stimulation of research, and the exchange of ideas and information. Through many committees it develops technical guidelines, policies, and information and cooperates with other organizations in the preparation of manuals and standards of transportation engineering practice. It publishes the Traffic Engineering Handbook (Ref. 3), the Transportation Planning Handbook (Ref. 4), the Manual of Transportation Engineering Studies (Ref. 5), and other reference material.

**Table 1-1—Employer Categories for North American Members of the Institute of Transportation Engineers\***

Employer Category	Number	Percent
<b>Government</b>		
<i>Federal (National)</i>	243	2.1
<i>State (Provincial)</i>	920	8.0
<i>County</i>	798	6.9
<i>City and other local</i>	2,291	19.8
<i>Regional Planning</i>	242	2.1
<i>Public Transit</i>	118	1.0
<i>Port and Toll Authorities</i>	64	0.6
<b>Consulting Firms</b>	6,204	53.7
<b>Educational Institutions</b>	389	3.4
<b>Manufacturers, Suppliers</b>	160	1.4
<b>Associations</b>	64	0.6
<b>Contractors, Construction Firms, Developers</b>	43	0.4
<b>Others (Railroads, Military, etc.)</b>	17	0.1
<b>Total</b>	11,553	100.0

\* Excludes retired, unemployed, and student members.

Source: ITE Membership Records, Oct. 2004.

**Table 1-2—Primary Transportation Mode Dealt With by North American Members of ITE, and Major Area of Responsibility**

Primary Mode	Percent of Respondents	Major Responsibility	Percent of Respondents
Street & Highway Traffic	73.3	Administration	25.0
General Transportation	13.3	Planning	24.1
Public Transportation	6.6	Operations	20.9
Air and Airports	0.8	Facilities Design	14.9
Utilities	0.5	Education, Research	5.4
Railroads	0.5	Safety	3.3
Ports and Waterways	0.2	Marketing	1.7
Other	4.7	Construction	1.5
		Maintenance	1.0
		Other	2.2

Source: Ref. 6.

While an increasing proportion of ITE members are transportation engineers in the broader sense, the great majority are still traffic engineers. The distribution of employer types in Table 1-1, therefore, is a fairly accurate indication of employment opportunities for traffic engineers.

A survey of ITE members (Ref. 6) listed the transportation modes with which respondents were primarily concerned, and the major areas of responsibility. These data (Table 1-2) represent about 3,150 ITE members in the U.S. and Canada who responded to this survey.

The same survey revealed that 91.5% of the responding members had at least one university degree; 46.1% had advanced to a Master's degree and 5.6% to a doctorate. Seventy-three percent were registered in one or more states as professional engineers, with another 7.2% holding an engineer-in-training certificate.

Traffic engineering has not generally been recognized as a separate specialty by the boards of registration of professional engineers in the various states. Traffic engineers have registered as civil or professional engineers, if at all. As of 1999, only Oregon licensed traffic engineers separately to practice. California enacted a title protection act for traffic engineers in 1975. However, this only controls the use of the title "traffic engineer," and does not prevent engineers registered in other engineering branches from practicing professional traffic engineering. Nor does it authorize traffic engineers to perform certain functions defined as civil engineering unless they are also registered as civil engineers or working under the supervision of a registered civil engineer.

The Institute therefore established a Professional Traffic Operations Engineer (PTOE) certification program to recognize minimum competency in this speciality. As of late 2005, about 1,500 certificates were active.

## D. Enforcement

Enforcement supplements traffic engineering and has the same objectives of safety and efficiency of traffic movement. The principal enforcement activities are the placement of limitations on who may drive and which vehicles may be operated on highway systems, the monitoring of obedience to traffic laws and the apprehension of violators, and the punishment and possible rehabilitation of convicted violators.

1. **Licensing and Inspection.** Licensing of drivers and inspection of motor vehicles are intended to assure that minimum standards for drivers and vehicles participating in the traffic system are met by removing habitual traffic violators and unsafe motor vehicles from the highways. These tasks are assigned to state agencies.
2. **Police Enforcement.** With the exception of some parking regulations, enforcement of traffic laws, together with responding to incidents and general patrolling, are the responsibility of city, county, and state police. It is a basic premise that every traffic law, ordinance, and control measure contributes to the safety and efficiency of traffic movement and should therefore be enforced for the health and safety of the community. Unenforced controls are considered worse than no controls at all, since they tend to cause some drivers to disregard them habitually and endanger others. Police also fulfill their objectives by patrolling highways, coming to the aid of stranded motorists, investigating accidents, and directing traffic in emergency situations.
3. **Court Disposition.** Traffic violation cases are generally referred for disposition to courts at the local government level. The courts determine the appropriate punishment designed to maintain respect for traffic laws and control measures and to encourage the improvement of the offender, if appropriate, by including compulsory attendance at safety lectures as part of the sentence.

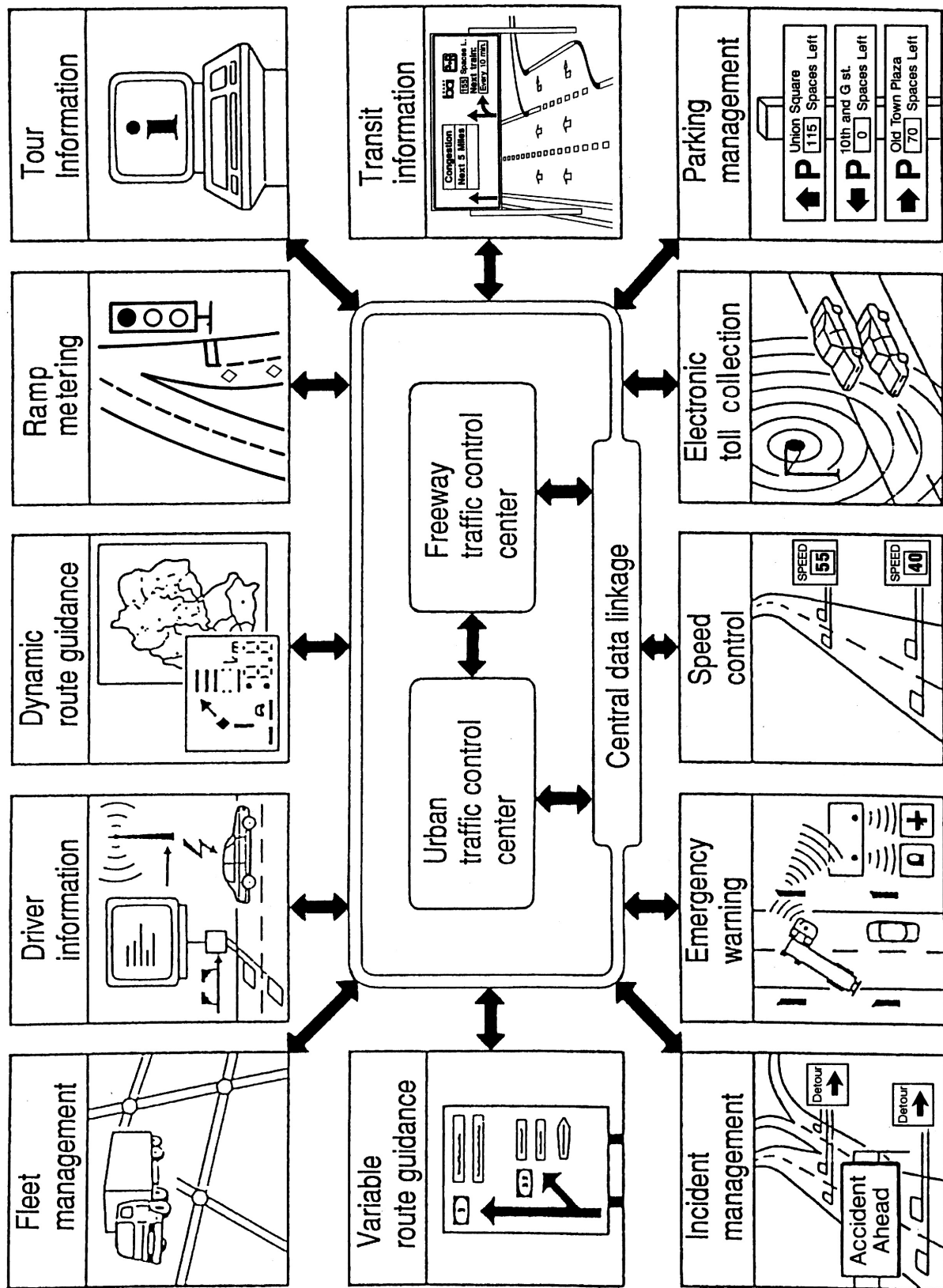

Fig. 1-3—Current and Future Applications of Integrated Traffic Controls

## E. Education

While most traffic experts agree that the safe use of streets and highways would be greatly enhanced if all users and policy makers were made fully safety conscious, there is no universal agreement on how to achieve such a happy state. Drivers, particularly those just learning, can take advantage of training programs. Pedestrians and bicyclists cannot be "educated" in a similar manner, except school children in the primary grades, who are typically given safety talks and training with the cooperation of local traffic engineers and police. Much effort is expended in attempts to reach the public through emphasis on traffic accident statistics in the news media, safety slogans, and campaigns, but there is no evidence that such means have been beneficial. Efforts have also been directed toward informing and educating elected officials and other policy makers to promote a better understanding of traffic and transportation engineering principles and practices.

### REFERENCES

1. Institute of Transportation Engineers. *ITE Directory*. Washington, DC: Internet Oct. 2004. Available to ITE members at [www.ite.org/directories](http://www.ite.org/directories).
2. Braess, H.-H., D. Frank, and D. Reister. "Individual Transportation Versus Mass-Transportation – Rivals or Partners?" (In German) *New Concepts for Traffic Flow and Parking Management*. Düsseldorf: VDI Verlag GmbH, 1990, p. 69.
3. Pline, James L. (Editor). *Traffic Engineering Handbook*. 5th Edition. Washington, DC: Institute of Transportation Engineers, 1999. 704 p.
4. Edwards, John A. (Editor). *Transportation Planning Handbook*. 2nd Edition. Washington, DC: Institute of Transportation Engineers, 1999. 865 p.
5. Robertson, H.D. (Editor). *Manual of Transportation Engineering Studies*. Washington, DC: Institute of Transportation Engineers, 2000. 624 p.
6. Institute of Transportation Engineers. *1985 North American Salary and Benefits Survey*. Washington, DC: 1985.

## A. Basic Structure of Transportation System

Transportation is a service devised to advance society by linking myriad locations where activity takes place wherever societies have found a use for land. These uses can extend across a region, nation, and, often, much of the world.

The transportation mission is accomplished by the provision of networks comprising:

### 1 **Links.**

- a. Physical links, e.g., tracks, roads, canals, pipelines, belts, and cableways.
- b. Navigational links, e.g., shipping lanes and airways.

### 2 **Means of movement.**

- a. Vehicles, e.g., ships, planes, motor and rail vehicles, bicycles, and nonmotorized vehicles.
- b. Belts, cable attachments (from tramway cabin to T-bar), pumps.

### 3 **Terminals.**

- a. Airports, maritime ports, rail and bus terminals, high-capacity parking facilities.
- b. Loading docks, bus stops, residential garages.
- c. Curb parking and loading zones.

## B. Transportation Systems Overview

Transportation systems include highways, rail, air, water, and continuous flow systems. Each is divided into specific modes. Many compete with each other, and some decline and disappear as advancing technology replaces them with more efficient alternatives. Each system and mode may be evaluated in terms of three attributes:

- 1 **Ubiquity.** The amount of accessibility to the system, directness of routing between access points, and flexibility to handle a variety of traffic.
- 2 **Mobility.** The quantity of traffic that can be handled (capacity) and the expeditiousness with which it is transported (speed).
- 3 **Efficiency.** The relationship between total costs (the sum of direct and indirect costs) of transportation and the productivity of the system. Direct costs are composed of capital and operating costs; the latter comprise expenses of the system operators and those of the users. Indirect (or "external") costs include miscellaneous items such as environmental impacts, resource depletion, and some accident cost items that are not included in normal direct cost accounts.

A very broad overview of these attributes of the major transportation systems and of the missions performed by the various modes is given in Table 2-1.

**Table 2-1—Overview of Major Transportation Systems**

System	Mode	Passenger Service	Freight Service	Ubiquity	Mobility	Efficiency
<b>Highways</b>	Truck	Negligible, except pickups used for person trips.	Intercity, local, farm-to-market, containers, small shipments.	Very high; land owners have direct access to a road or street. Direct routing limited by terrain and land use.	Speeds limited to ca. 120 km/h by human factors and speed limits. Capacity per vehicle is low, but many vehicles are available.	Not high as regards energy consumption, safety, and operating costs.
	Bus	Intercity and local.	Packages (intercity).			
	Automobile	Intercity and local.	Personal items.			
	Bicycle	Local.	Minor amounts.			
<b>Rail Transport</b>	Railroad	Mostly < 500 - km trip length and suburban commuters.	Mostly bulk and oversize shipments: intercity, containers.	Limited by large investment in route infrastructure. Also constrained by terrain.	Speed and capacity can be higher than for highway modes. High-speed passenger trains operate at 300 km/h.	Generally high, but labor work rules may result in cost inefficiencies.
	Rail transit	Regional, intracity.	None.			
	Air carrier	Mostly < 500 - km trip length and across bodies of water.	High-value shipments on long hauls, some in containers.			
<b>Air Transport</b>	General aviation	Intercity, business, recreation.	Minor.	High cost and noise impacts reduce number of airports and, hence, accessibility. Good opportunity for direct routing.	Speeds are highest (to 900 km/h in subsonic mode), but capacity per aircraft and aircraft per runway per hour are limited.	Fairly low as regards energy consumption and operating costs.
	Ship	Cruising, ferry service.	Bulk cargos, especially petroleum and minerals; containers.			
	Barge	None.	As above.			
<b>Water Transport</b>	Hovercraft	Ferry service.	Minor.	Accessibility and direct routing limited by availability of navigable waterways and safe ports.	Low speeds, Capacity per vessel can be very high.	Very high – low operating costs and energy use. Safety varies.
	Pipeline	None.	Liquids (e.g., petroleum), gases, slurries; short and long hauls.			
	Belt	Escalators and belts for short distances.	Bulk materials, mostly short hauls.			
<b>Continuous Flow Systems</b>	Cable	Aerial gondolas and tows for short distances.	Materials handling in rough terrain.	Limited to few routes and access points. Cable can be routed fairly directly across rough terrain.	Low speeds. High capacity.	Generally high – low operating cost, low to medium energy use.
						Low speeds and capacity.

### C. Transportation System Performance in the United States

The relative shares of total expenditure for transportation and of traffic carried in the U.S. in a recent year are shown in Table 2-2. Almost 90% all passenger travel is by highway vehicle. Distribution of freight traffic among modes is, however, more widespread: railroads carry 37% of the total; trucks, pipelines, and ships follow with decreasing shares of traffic.

The long-range trend in total traffic carried by all systems except Amtrak has been generally upward. In the 10-year period to 2003, person travel (measured in passenger • kilometers) increased about 2% per year. However, a higher growth rate occurred within the highway mode in 2-axle, 4-tire motor vehicles, i.e., vans, sports utility vehicles, pickup trucks, and other small trucks.

The annual growth rate for freight movements on all modes was 1.6%. Only water-borne freight saw a decline in this period, mostly because of decreases in shipping on the Great Lakes.

The highway system, the primary concern of traffic engineering and of this syllabus, accommodates almost 90% of all passenger travel and 30% of the freight traffic in the U.S. Further details on highway traffic trends are given below.

**Table 2-2—U.S. Domestic Transportation System Shares, 2001/3 and 10-Year Trends**

Mode†	Expenditures		Person Travel psgr•km‡		Freight Traffic t•km		Network Extent km x 10 <sup>3</sup>
	2001 Share	10-year Trend	2003 Share	10-year Trend	2003 Share	10-year Trend	
<b>Highways</b>	<b>83.9%</b>	<b>+5.5%</b>	<b>89.2%</b>	<b>+2.0%</b>	<b>29.0%</b>	<b>+3.1%</b>	<b>6382</b>
Automobile <sup>1</sup>	53.3	+5.7	49.5	+1.8	NA	NA	
2-axle 4-wheel <sup>2</sup>	Incl. with Trucks		32.6	+3.1			
Truck	29.8	+5.5	4.8	+3.1	29.0	+3.1	
Intercity bus	0.1	-1.5	2.8	+1.0			
School bus	0.8	+4.8			NA	NA	
Local Transit	1.9	+5.8	0.9	+2.0	NA	NA	
<b>Railroad<sup>4</sup></b>	<b>2.8</b>	<b>+2.5</b>	<b>0.1</b>	<b>-0.9</b>	<b>36.8</b>	<b>+3.5</b>	<b>161</b>
Air	8.8	+4.7	9.8	+3.1	0.3	+2.7	
General aviation			0.2*	+1.5*			
Air carrier			9.5	+3.1	0.4	+2.7	
<b>Water<sup>5</sup></b>	<b>2.0</b>	<b>+3.9</b>	<b>NA</b>	<b>NA</b>	<b>13.9</b>	<b>-2.6</b>	<b>42<sup>6</sup></b>
Pipeline <sup>7</sup>	0.6	1.1	NA	NA	19.9	0.1	
<b>Totals (x 10<sup>9</sup>)</b>	<b>\$1569</b>	<b>+5.2</b>	<b>8500</b>	<b>+2.5</b>	<b>7000</b>	<b>+1.6</b>	<b>-</b>

Source: Extracted and Adapted from Ref. 1.

† - There are no data for non-motorized modes, i.e. bicycle and walking trips.

‡ - For highway travel, includes driver•km.

\* - Estimated from 2002 data.

NA - Not applicable or negligible.

Blank cells -Data not available.

1 - Includes motorcycles and taxis.

2 - Includes pickups, SUVs, vans, and small trucks.

3 - Fixed guideways only; includes commuter rail.

4 - Class I and Amtrak.

5 - Excludes commercial fishing.

6 - Inland and coastal channels.

7 - Oil and Natural Gas; excludes service lines.



### D. Highway System Performance in the United States

Selected financial, inventory, and performance statistics of the U.S. highway system are given in Table 2-3. Most trends shown in this tabulation have been upwards; the only negative trend reflects the transfer of rural roads to urban status. Because the financial data are in current dollars, these indicators have risen more rapidly than those describing performance. The intercity bus industry is the exception, showing only a modest increase in current dollar revenues from 1994 to 2003.

1 **Motor Vehicle Registration and Ownership.** The total number of motor vehicles registered has increased steadily throughout their history except during World War II (Fig. 2-1). However, the ratio of motor vehicles to population has leveled off at near 80 vehicles per 100 population. In 2001, about 8% of all households were without a motor vehicle, while 37% owned two, and 23% owned three or more (Table 2-4).

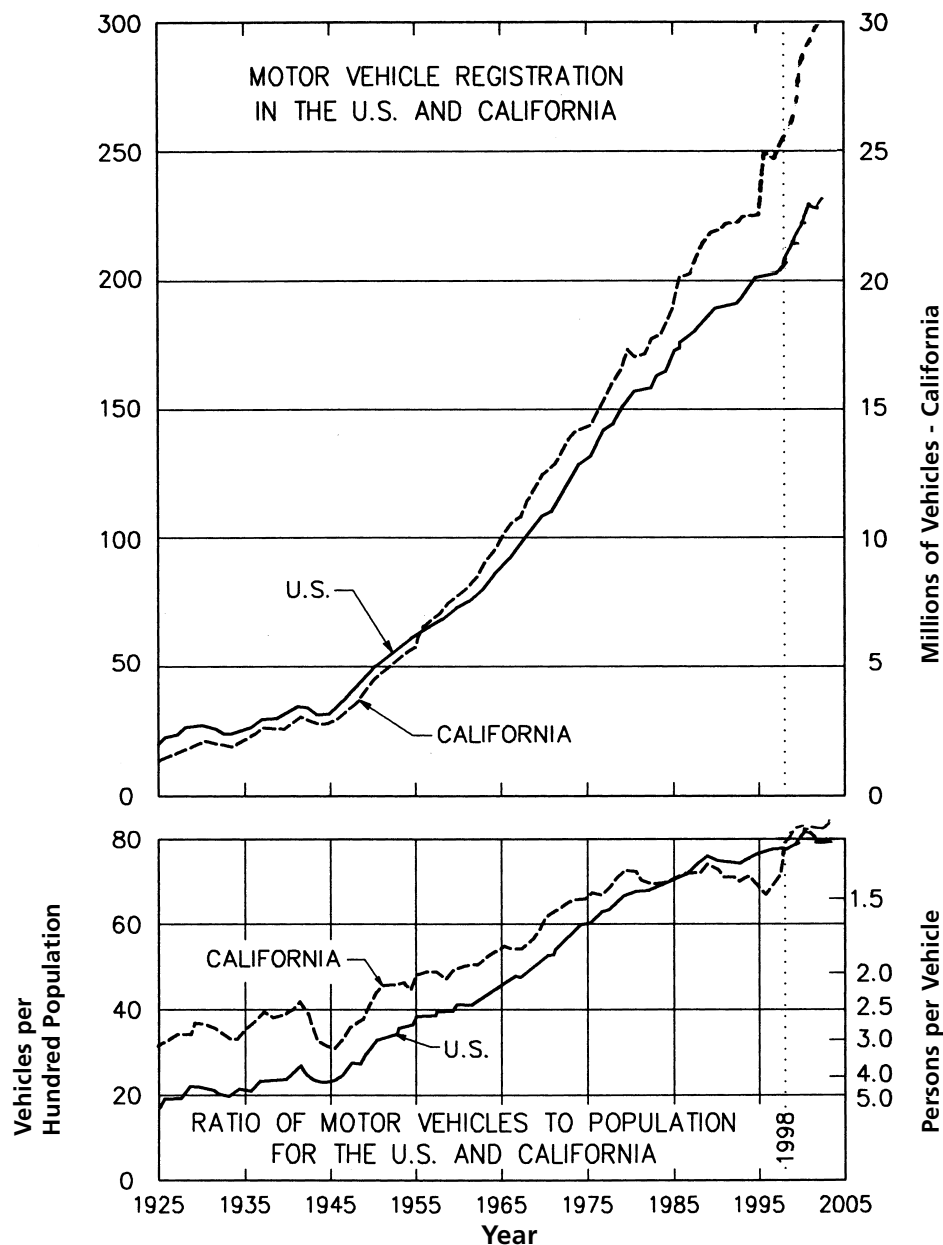

Fig. 2-1—Trends in Motor Vehicle Statistics, U.S. and California

Occupants of households without vehicles are largely dependent on public carrier transportation and tend to be concentrated in large cities. In metropolitan areas of more than 3,000,000 population the proportion of households without cars in 1995 was 11.2% ; and in those parts of cities in which population density exceeds 3,860 persons/km<sup>2</sup>, 31% of households did not have a motor vehicle available.

**Table 2-3—Trends in Selected U.S. Highway Statistics**

	1994	2003	9-year annual trend
<b>Financial (in \$ x 10<sup>6</sup>)</b>			
Government expenditures on highway systems	90,190	143,810	+5.3%
Private expenditures on autos	445,000	650,000	+4.3%
Truck industry revenues	155,700	225,900	+4.2%
Intercity bus revenues	1,160	1,345	+1.6%
Local transit revenues	17,970	26,630*	+5.0%*
<b>Inventory (in thousands)</b>			
No. of motor vehicles	206,900	243,000	+1.8%
Rural network (km)	4,976	4,880	-0.2%
Urban network (km)	1,310	1,514	+1.6%
<b>Performance (in billions)</b>			
Total traffic (veh•km)	3,795	4,650	+2.3%
Passenger travel (psgr•km)	6,045	7,380	+2.2%
Freight traffic - intercity (t•km)	1,600	2,035	+2.7%

\* - Data for 2002 and 9-year trend.

Source: Compiled from Ref. 1.

**Table 2-4—Vehicle Availability in U.S. Households**

Vehicles or Persons per Household	Year of Survey					
	1969*	1977	1983	1990	1995	2001
<b>Vehicles</b>						
Percent of Households						
None	20.6	15.3	13.5	9.2	8.1	8.1
One	48.4	34.6	33.7	32.8	32.4	31.4
Two	26.4	34.4	33.5	38.4	40.4	37.2
Three or more	4.6	15.7	19.2	19.6	19.1	23.2
<b>Persons</b>						
Number per Household						
All persons	3.16	2.83	2.69	2.56	2.63	2.58
Licensed drivers	1.65	1.69	1.72	1.75	1.78	1.77

\* - Passenger cars only; other years include pickups and vans.

Source: Refs. 2 and 3, See NOTE on page 2-6.

- 2 **Trends in Vehicle Travel.** Travel is generally measured in vehicle•kilometers of travel (VKT or veh•km), the product of the number of vehicles and the average distance they travel. Passenger cars and 2-axle, 4-tire vehicles, which comprise 94 % of all U.S. motor vehicles, are driven an average of about 20,000 km and 18,000 km per annum respectively; the figure for passenger cars has grown only slowly from around 15,000 km 40 years ago. The annual use of larger trucks has also changed little in recent years. About 40 % of total travel is on rural highways, 60 % in urban areas. Table 2-5 gives data on annual travel and fuel consumption for different types of vehicles.

**Table 2-5—Annual Motor Vehicle Use and Fuel Consumption, 2004**

Type of Vehicle	Registered Vehicles x 10 <sup>6</sup>	Travel				Fuel Consumption	
		Rural <sup>1</sup> Veh•km x 10 <sup>9</sup>	Urban <sup>1</sup> Veh•km x 10 <sup>9</sup>	Total Veh•km x 10 <sup>9</sup>	Average km/veh	Amount L/veh	Rate km/L
Passenger car	136.4	930	1742	2743	20,113	2108	9.6
2-axle, 4-tire vehicle <sup>2</sup>	91.8	606	1000	1632	17,770	2582	6.9
Motorcycle	5.8	7	8	15	2800	132	21.2
Single-unit truck <sup>3</sup>	6.2	197	150	130	21,160	5690	3.7
Truck combination	2.0						
Bus <sup>4</sup>	0.8	6	5	11	13,430	4512	3.0
<b>All vehicle types</b>	<b>243.0</b>	<b>1746</b>	<b>2905</b>	<b>4766</b>	<b>19,613</b>	<b>2707</b>	<b>7.2</b>

Source: Ref. 1, Tables 4.11 through 4.15 and modal profiles.

<sup>1</sup> 2003 data in this column<sup>2</sup> Includes vans, pickup trucks, and sport/utility vehicles<sup>3</sup> Includes trucks with at least 6 tires; rural/urban veh•km includes truck combinations..<sup>4</sup> Intercity and school buses.**3 Trip Lengths.** In California in 2000 (Ref. 4):

- One half of all trips in private motor vehicles were less than 15 minutes; two thirds were under 20 minutes in duration.
- Only 6% of all trips exceeded one hour in length.

This pattern has adverse implications with respect to air pollution and energy consumption; see Chaps. 30 and 32. The average length of transit trips is 8 km (Ref. 1). Some nationwide data on vehicle trip lengths are shown in the last column of Table 2-6.

**Table 2-6—Annual Person Trip Rates and Amount of Travel by Trip Purpose, per Household, 2001**

Trip Purpose	Annual Trips Household		Annual Travel per Household		Average Trip Length km
	Number	Percent	Person•km	Percent	
To/from work	565	15.8	10,790	19.1	19.5
Work-related business	109	3.0	4806	8.5	45.5
Shopping	707	19.7	7863	13.9	11.3
Other family/personal business	863	24.1	10,734	19.0	12.6
School/church	351	9.8	3315	5.9	9.7
Social and recreational	952	26.6	17,033	30.1	18.3
Other	30	0.8	1957	3.6	64.3
<b>All purposes</b>	<b>3581</b>	<b>100.0</b>	<b>56,498</b>	<b>100.0</b>	<b>16.1</b>

Source: Computed from Ref. 3, Table 5.

*NOTE: Refs. 3 and 5 report on a survey sample that "excluded households without telephones. Care should therefore be taken in interpreting results that might be affected by telephone ownership (which is related to household income)." Ref. 3, page 18.*

**4 Household Trip Patterns.** Table 2-7 summarizes demographic trends in U.S. households. Since 1969 household size has steadily decreased whereas the number of vehicles and licensed drivers per household have increased. The implications of these trends on trip making per household are obvious.

Data from the 2001 National Household Travel Survey (Ref. 3) show annual trip-making per household (including both weekday and weekend travel). About 16% of all household trips were made in connection with earning a living, 20% for shopping, and 25% each for other family/personal business and for social and recreational purposes. Trip lengths were highest for work-related travel and lowest for school/church and shopping trips.

**Table 2-7—Demographic Trends of U.S. Households—1969-2001**

	1969	1977	1983	1990	1995	2001
Persons per household	3.16	2.83	2.69	2.56	2.63	2.58
Vehicles per household	1.16	1.59	1.68	1.77	1.78	1.89
Licensed drivers per household	1.65	1.69	1.72	1.75	1.78	1.77
Workers per household	1.21	1.23	1.21	1.27	1.33	1.35
Vehicles per worker	0.96	1.29	1.39	1.4	1.34	1.39

Source: Ref. 3, Table 2.

- 5 **Trip Mode.** Table 2-8 summarizes the modes used for different trip types in the U.S. in 2001. These data refer only to trips made on one day in the households being surveyed and do not report on trip segments that were more than one day in length. The data show that about 86% of all household trips were by private vehicle and almost 10% by walking or bicycle. These data vary from rural to urban areas and with urban area size.

**Table 2-8—Distribution of Person Trips by Mode and Purpose, 2001**

Trip Purpose	Private Vehicle %	Public Transit %	Walk/ bicycle %	Othert %	All Purposes %
To/from work	14.6	0.6	0.4	0.2	15.8
Work-related business	2.8	0.1	0.1	0.1	3.0
Family/personal business*	39.9	0.5	3.1	0.4	43.8
School/church	7.0	0.2	0.5	0	5.4
Social/recreational	14.8	0.3	3.2	0.2	18.5
Other	7.3	0.2	0.4	0.1	8.0
<b>All purposes</b>	<b>86.4</b>	<b>3.5</b>	<b>9.5</b>	<b>0.5</b>	<b>100.0</b>

Source: Ref. 3, Table 9.

\* Includes shopping

† Includes taxi and truck.

## E. Urban Travel Characteristics

Many of the problems dealt with by the traffic engineer occur in urban areas, where the demand for transportation per unit of land area is extremely high. Urban travel patterns, therefore, are discussed further in this section. (For more details, see Ref. 6.)

- 1 **Historical.** Transportation technology has had a profound influence on economic and social development and the growth of cities. In the 19th and early 20th century, streetcar lines were chiefly responsible for development of concentrated central business districts (CBDs) and residential areas of medium density strung out along major corridors. Passenger services on major railroad lines, soon to be supplemented by routes dedicated entirely to commuter train operations, stimulated the growth of nearby villages and towns into suburbs of the central city and gave rise to new suburban communities. Gridiron layouts of streets were generally used to facilitate land subdivision and to provide access to property. The streets were not intended nor expected to accommodate large numbers of vehicles. It has been estimated that in the first decade of the 20th century 20% of urban travel was via streetcar.

After 1910, urban development was influenced greatly by technological changes in both transportation and industry. Mechanization of agriculture resulted in decreasing need for human effort and a major migration of rural populations to cities. Motor vehicle transportation allowed and encouraged radical changes in the form of cities and the use of land. Cheap land in the outer parts of cities and in the agricultural or undeveloped territory beyond became attractive to developers. Most of the new housing was in the form of single-family homes on generously sized lots. Urban renewal projects generally resulted in a reduction in residential densities. Automobiles were easily able to serve such residential areas, while walking became more difficult, given the longer distances involved, and mass transportation found decreasing numbers of potential patrons per kilometer of route.

Shopping centers followed the population to the new residential locations. Featuring several large department stores as "anchors" and prolific amounts of free parking, they soon reduced the role of downtown retail stores to serving the daytime population (the workers) and a few loyal customers from elsewhere. At the same time, the convenience goods industry shifted from small stores to mass merchandising, turning the almost daily walk to the neighborhood grocery into a weekly expedition to the supermarket, the drugstore, or the "big box store," that could best be accomplished by using the automobile as the freight carrier.

After World War II, manufacturing deserted the central city for outlying areas and even beyond. Changes in the role of railroads and trucks were important contributory causes. Railroad companies sold old freight yards and terminals near downtown (e.g., Denver, San Francisco, Toronto) for higher and better land uses, and industries found cheaper land in the suburbs, where railroads were willing to build new freight spurs. New industry can eschew large cities entirely and locate in rural areas, provided that sites are near a railroad line; the motor vehicle manufacturing plants built in Ohio and Tennessee in the 1980s illustrate this trend. Other industries, including the enormous electronics sector, found that they could be well served by trucks, and that locations alongside a railroad were of no particular value. More recently, "outsourcing" has transferred much manufacturing to foreign countries reducing demand for industrial land in the U.S.

- 2 **MACs and CBDs.** Thanks to vastly increased communications and data transmission systems, the extensive availability of computers, and the profusion of internet access, many employers are now able to move work forces from expensive downtown locations to lower-cost office parks in the suburbs. This has given rise to suburban employment centers (also called Major Activity Centers or MACs) that, in some cases, exceed the CBDs of their regions in the number of jobs and the quantity of floor area. Such centers depend largely on private vehicle access, since no strong radial travel patterns exist that would support a frequent mass transit service. Provision of sufficient land for employee parking, not to mention additional highway capacity, then becomes inevitable. However, planning permission for many of these MACs includes requirements for Traffic Demand Management programs. (see Chap. 34.)

The CBD nevertheless remains the focus of radial highway and transit networks. Because of the great amount of accessibility that this affords, corporation headquarters, financial institutions, and supporting businesses, as well as specialized services, retail stores, government offices, and courts still find the CBD to be the optimum location within an urbanized area.

- 3 **Urban Trip Length.** The size of the population in a metropolitan statistical area (MSA) seems to have little effect on trip lengths (Table 2-9, bottom row). The work/work-related trip purpose produces longer trip lengths than do the others, while school/church and shopping produce the shortest.
- 4 **Urban Trip Quantities.** The number of trips made is a manifestation of the types and amount of activities taking place on urban land as well as a reflection of the costs of travel. In large metropolitan areas, trip costs tend to be high, and somewhat fewer trips are made. The number of trips per capita by private vehicle declines slightly for larger metropolitan statistical areas, and trips on foot and by public transit increase.

Trip-making in households where no private vehicle is available is substantially lower than in households that have access to vehicles. The proportion of households without vehicles is shown in the last line of Table 2-10.

The tendencies for the number of trips per capita to decrease with increasing urban area size while average trip length increases slightly cancel each other when the data are multiplied to calculate per capita travel expressed in vehicle•km. Hence, little variation is found in this statistic for different urban area sizes. For all trip purposes, it is about 45 person•km per day.

- 5 **Trip Mode.** As shown in Table 2-9, there are more transit trips and more walking trips in large urbanized areas than in smaller ones.

**Table 2-9—Average Person Trip Length (km) by Size of Urbanized Area and Trip Purpose, 2001**

Trip Purpose	Trip Length (km) in Areas (MSA) of Population Size (Thousands)						
	< 250	250-500	500-1000	1000-3000	> 3000	Not in MSA	All
To work/work-related	22.6	19.5	28.2	23.7	27.2	25.2	25.1
Family/personal business	18.7	17.5	14.1	16.8	15.4	23.9	17.8
School/church	9.7	10.8	9.8	10.3	8.9	12.0	10.1
Social/recreational	17.9	17.4	15.5	18.7	17.3	22.0	18.4
Shopping	10.4	9.7	10.9	10.2	9.2	13.7	10.6
Coming home	14.6	13.9	14.9	13.7	13.9	18.0	14.8
Other	21.3	24.4	11.0	18.6	17.4	19.7	18.4
<b>All Purposes</b>	15.7	15.2	15.0	15.5	15.2	18.8	16.0

Source: Computed from data in Ref. 5.

**6 Peak Period Traffic Patterns.** Normal weekday travel via both motor vehicles and transit reaches peaks between 7 and 9 am and between 4 and 6 pm. However, as peak period travel demand approaches or exceeds the capacity of the highway network or of a specific facility, peak periods spread beyond these limits, sometimes lasting more than three hours. The peaks for transit, as a percentage of 24-hour traffic, are much higher than those for motor vehicles (see Fig. 2-2).

**Table 2-10—Trips per Capita, by Size of Urbanized Area and Mode of Transportation, 1990**

Mode	Trips per Capita per Day in Areas of Population Size (Thousands)				
	< 250	250-500	500-1000	1000-3000	> 3000
Private vehicle (PV)	2.88	2.49	2.34	2.50	2.16
<i>Auto driver</i>	1.75	1.57	1.46	1.61	1.43
<i>Auto passenger</i>	0.71	0.59	0.58	0.62	0.54
<i>Pickup and other PV</i>	0.41	0.32	0.30	0.26	0.19
Public transit†	0.03	0.02	0.03	0.05	0.11
School bus	0.08	0.07	0.07	0.06	0.05
Walk	0.20	0.17	0.13	0.18	0.28
Bicycle	0.03	0.01	0.01	0.01	0.02
All Modes††	3.23	2.77	2.59	2.82	2.65
Households without available PV	8.6%	5.7%	8.4%	8.2%	12.4%

Source: Ref. 5.

† - Unreliable data because of small sample obtained. †† - Includes "other modes"

- a. *Motor vehicle traffic.* For peak period volume characteristics, see Chapter 5.
- b. *Mass transit.* The hourly demand for mass transit in peak periods is an order of magnitude higher than that for midday hours. In part, this peaking pattern is accommodated by offering a lower level of service in the peak, i.e., forcing many passengers to stand. Even this does not eliminate a major productivity problem for transit systems—the large number of vehicles and operators required to provide morning and afternoon peak service, many of which are not needed at any other time of the day or on weekends. The San Francisco data are typical of a city with high land-use densities; less dense urban areas, such as those served by nearby Alameda County Transit, have an even greater disparity between peak period and off-peak needs. (Table 2-11)

This disparity results in the fact that many bus drivers and transit operators perform useful service during only a few hours of the day. Nevertheless, under most union contracts, they must be paid wages for at least eight hours. This puts a heavy financial burden on transit operators.

The two weekday peak periods generally produce similar travel demands, but their purposes differ slightly. In the morning, trips to work and those to school coincide or overlap; the afternoon peak, on the other hand, includes travel by shoppers and—in some cities—by tourists, in addition to home-bound commuter trips.

**Table 2-11—Transit Equipment Requirements**

Time of Day	San Francisco Muni Railway		A. C. Transit District	
	Vehicles in Service*	Percent of Peak Requirement	Vehicles in Service	Percent of Peak Requirement
Weekdayst				
Morning peak	725	98	593	99
Midday base	486	66	315	53
Afternoon peak	741	100	597	100
Evening	257	35	161	27
Saturday base	381	51	246	41
Sunday base	345	47	197	33

\* - Excludes cable cars. † - During school year.

**7 Traffic Problems of Urbanized Areas.** The concentration of trip ends in urban areas and the resulting concentration of travel demand result in a number of problems that are considered of great importance by the general public and by policy makers. A short list follows; these and other problems will reappear in subsequent chapters of this syllabus.

- General congestion and restriction on mobility.
- Unreliability and unpredictability of system performance—system breakdown.
- Environmental impacts, especially air pollution and noise.
- Impact of traffic on the quality of life in residential areas.

**8 Special Traffic Problems of the Central Business District (CBD).**

- a. The number of daily trips to the CBD depend on such factors as total population, geographic distribution of that population with respect to the CBD, number of jobs in the CBD, the level of vehicle ownership, the extent and quality of mass transit service, the adequacy of parking facilities in and near the CBD, the types of goods and services offered, and the strength of competing shopping and commercial areas. Total trips going to the CBD for all purposes add up to roughly 125 per thousand for the first two million people in the region and about 75 per thousand above two million.
- b. Mass transit's share of travel to the CBD is greater in large cities than in small ones. However, population is not the only criterion; other factors affecting mode choice include density of the urban area, employment density in the CBD, the rate of motor vehicle ownership, the location and price of available parking, and the quality of transit service. Walking distances are important components of the total trip to be considered when evaluating parking and transit service quality.
- c. The role of mass transit in serving the CBD of a large city is illustrated in Fig. 2-3, which shows, by hours of the day, the accumulations of persons in Chicago's CBD. Note that a very high percentage of the people in the area at any hour arrived via mass transit.
- d. The parking problems created by the concentration of many motor vehicle trip ends in the CBDs of metropolitan areas are discussed in Chap. 10, Sec. E.

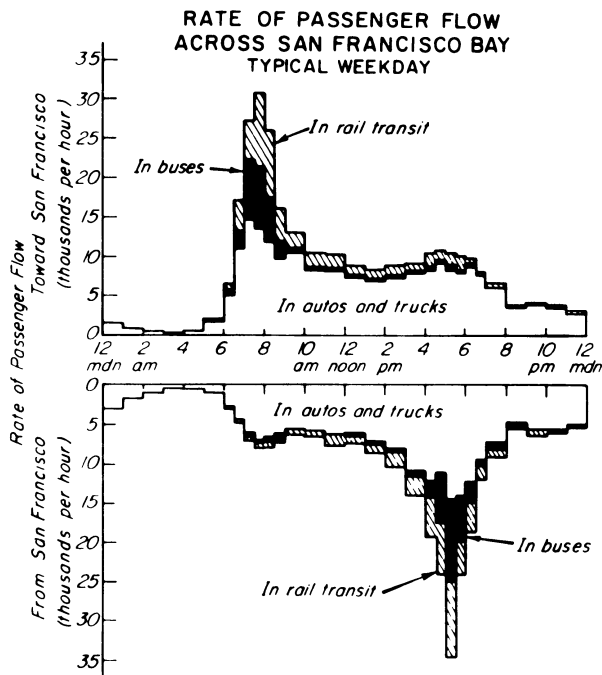

**Fig. 2-2—Peaking Characteristics in a Major Commuter Corridor**

Source: Ref. 8.

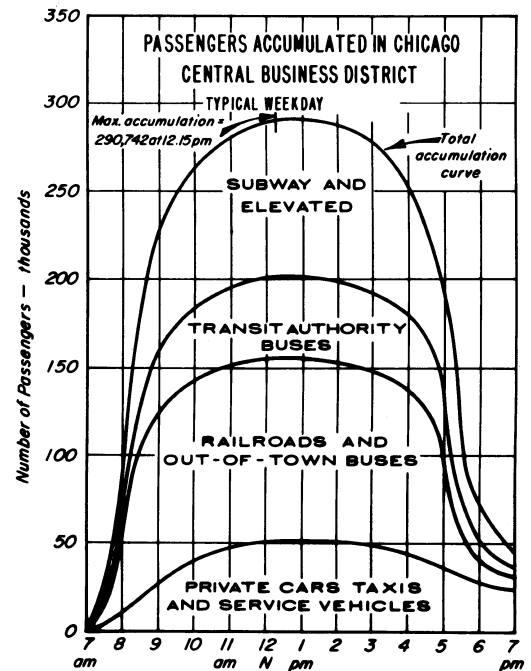

**Fig. 2-3—Pattern of Accumulation of Persons in a CBD by Mode of Arrival**

Source: Ref. 9.

**REFERENCES**

1. U.S. Dept. of Transportation. Bureau of Transportation Statistics. *National Transportation Statistics 2005*. Washington, DC: As of Jan. 2006. Available at: [http://www.bts.gov/publications/national\\_transportation\\_statistics/2005/index.html](http://www.bts.gov/publications/national_transportation_statistics/2005/index.html).
2. Hu, P.S., and J.P.Young. *Nationwide Personal Transportation Survey: 1995*. Washington, DC: Dec. 1999. Available at: [http://www-cta.ornl.gov/npts/1995/Doc/NPTS\\_Booklet.pdf](http://www-cta.ornl.gov/npts/1995/Doc/NPTS_Booklet.pdf).
3. Hu, P.S., and T.R. Reuscher. *Summary of Travel Trends. 2001 National Household Transportation Survey*. Internet, Dec. 2004. Available at <http://nhts.ornl.gov/2001/Analysis.do?state=ttPrompt>. See also: The Editors of New Strategist Publications. *Access to the 2001 National Household Travel Survey: the Demographics of Daily Travel*. Ithaca, NY: 2004.
4. California Dept of Transportation. *2000-2001 California Statewide Household Travel Survey. Final Report*. Austin, TX. NuStats. June 2002.
5. Oak Ridge National Laboratory. *2001 National Household Transportation Survey*. Internet, Dec. 2004. Available at <http://nhts.ornl.gov/2001/index.shtml>.
6. Anderson, M.D. "Urban Travel Characteristics." In: *Transportation Planning Handbook*. 2nd Edition, Washington, DC: Institute of Transportation Engineers, 1999. Chapter 4.
7. Smith, Wilbur, & Associates. *Urban Transportation Concepts*. (Center City Transportation Project.) Springfield, VA: National Technical Information Service, Document PB 198 603, Sept. 1970, Fig. 5.
8. University of California, Institute of Transportation Studies. *Traffic Survey Series A-47*. Berkeley, CA: Oct. 1976.
9. City of Chicago, Bureau of Street Traffic. *Cordon Count Data of the Central Business District*. IL: Annual.





### A. Human Characteristics

Human beings—as vehicle operators and pedestrians—are prime elements in highway traffic and must be properly guided and controlled. Behavior of individual drivers in a traffic stream is frequently the factor that establishes the characteristics of that traffic. Pedestrian performance capabilities are often below the minimum standards expected of licensed vehicle operators, and this must be recognized in designing for their control. (See Chap. 22.)

The human information process (Ref. 1, Chaps. 3 - 5) may be thought of in computer system terminology:

1 **Input:** reception of current information via senses.

2 **Central processing by the brain:**

- a. *Perception:* the brain interprets the sensory information.
- b. *Intellection:* includes reasoning, problem solving, and decision making.
- c. *Movement control:* the brain sends instructions to parts of the body.

Processing utilizes *memory* (like a computer) and is driven by *motivation* (not like a computer).

3 **Output:** body responds to brain's instructions to move.

### B. Reception of Information Through the Senses

1 **Vision** is the most important physical factor for drivers and pedestrians (Ref. 2).

- a. *Acuity* varies with each individual, but also with the level of illumination, and increases with the length of viewing. Hence, 20/40 vision in daylight may be only 20/200 vision in darkness. Minimum standards of acuity must be met (corrected or uncorrected) before a driver's license is issued; however, tests are based on performance in good illumination.
- b. *Cone of vision.* The best vision occurs within a cone of 3°, clear vision within 10°, and satisfactory vision within 20°. Traffic signs and markings should fall within the cone of clear vision, since acuity for reading drops rapidly outside this limit. As travel speed increases, the driver's cone of vision decreases. Fig. 3-1 shows the reduction in what a driver can easily see as travel speed increases from 50 to 65 km/h. The focus of the driver's vision tightens on the roadway ahead, as objects along the side of the road fall into the background. This reduction in peripheral vision increases the chance that the driver will not recognize a pedestrian moving unexpectedly into the roadway early enough to avoid a collision.

- c. *Eye movement*: After jumping from one point to another, the eye fixates on what it is seeing, a process that takes 0.20–0.25 s. The eye must follow moving elements in traffic and must compensate for head movements. It often moves involuntarily in response to noise or other stimuli. The eyes must work together (converge) for binocular vision.
- d. *Depth perception* is important for judging distances and speeds, and the primary method is by binocular vision (stereopsis). But monocular parallax (detection of movement within a scene), perspective, and atmospheric clues (reductions of contrast or sharpness with increased distance) may provide alternative means for judging speed and distance.
- e. *Peripheral vision* is the ability to perceive objects outside the cone of clear vision. Because of the limit of 4–5 eye fixations per second, peripheral vision is important for obtaining a complete view. The angle of peripheral vision ranges from 120° to 180°, but reduces at higher speeds (e.g. to 40° at 100 km/h). Tunnel vision can be compensated for by moving the head.
- f. *Visual attention* is confined to the area of clear vision. At increasing speeds the eyes focus further ahead.
- g. *Visual sensitivity to color*: About 8% of all men and 0.5% of all women suffer some degree of color blindness, primarily a reduced ability to distinguish between red and green. Blueish green is less difficult to identify and is therefore used in traffic signal lenses. In general, color differentiation is easier in the middle of the color spectrum than near its edges.



At 50 Km/h the driver begins to see things at the road edges in the background



At 65 Km/h the driver's focus is on the roadway in the distance.

Photos by Judith Greene-Janse

**Figure 3-1–Driver's "Cone of Vision"**

- h. *Glare vision and recovery*: Going from darkness to light, pupils contract in about 3 s. However, when going from light to dark, pupil dilation takes 6 s or more. Increased age and wearing of glasses reduce the ability to overcome glare difficulties. Glare discomfort may be increased by dirty or scratched windshields.
  - i. *Visual deterioration among elderly persons* (Ref. 3, v. 1, p. 55-58): Vision generally deteriorates with increased age because the lens of the eye yellows and hardens, which reduces transmittance of light to the retina. Cataracts and glaucoma become more common. Eyesight is checked in most states when drivers' licenses are renewed.
  - j. *Pedestrian vision*: There are no minimum eyesight requirements for pedestrians. Some are blind, others have some vision, but not enough to read signal indications or detect vehicles at a distance.
- 2 **Hearing.** Lack of hearing acuity presents no major problem to drivers, but may for pedestrians, who tend to rely on sound cues to detect the presence of vehicles. Hearing generally deteriorates with age, but has not been shown to be the cause of more accidents involving elderly drivers.
  - 3 **Stability Sensations.** Drivers react to feelings of instability, such as are caused by rough roads, sharp curves, or steep cross slopes. Loss of sensations may eliminate awareness of these hazards.

### C. Perception, Intellection, and Movement Control

These activities occur in the brain with input from memory and stimulus from motivation. Physical and psychological factors often play a role in information processing too, and are briefly mentioned here.

- 1 **Memory,** based on past experience, develops skills, habits, and abilities to respond properly to the traffic environment.
- 2 **Conditioned Response.** Based on long-term memory, habit creates conditioned responses to familiar situations and stimuli. Drivers using the same street repeatedly will assume that the geometry, controls (even to the level of detail of anticipating the start of the green interval of a signal), and traffic conditions do not change from day to day. Pedestrians also have conditioned responses, such as looking to the left first when crossing a street. Difficulty must be expected when long-established habits are to be changed.
- 3 **Motivation.** Important motivating factors involved in driving or walking are:
  - a. Desire to act safely, including the desire to predict the behavior of others in the vicinity.
  - b. Desire to accomplish the task/trip as expeditiously as possible.
  - c. Comfort and convenience.
  - d. Desire for privacy; security from accidents and crime.
- 4 **Implementing Decisions.** An individual's strength, range of movement, and coordination determine the speed and accuracy with which decisions reached by processing input information are actually carried out, if at all. Further discussion of these factors is beyond the scope of this syllabus, except to note the special attention to be paid to the physically handicapped, who may be deficient in some or all of these attributes, and to the elderly driver and pedestrian.

### D. Perception-Response Time

- 1 **Perception-Response Time.** Ref. 4 reports the mean perception-response time (PRT) to an unexpected condition is about 1.10 s; the 95th percentile time is 2.0 s. For an expected obstacle, the mean PRT is 0.65 s. The literature agrees that almost all drivers are capable of responding to an unexpected hazard in 2.0 s or less.

In traffic safety analysis it is necessary to assume the longest response and add 0.5 s for vehicle brake reaction time. For design and operations analysis purposes, therefore, a perception-brake-response time (PBRT) value of 2.5 s is used. In the case of large trucks, allowance might be made for the lag time until all wheels lock, perhaps another 1.0 to 1.5 s.

PRT is modified if the person is subject to one or more of the factors listed in C. 4. above. *Weather, time of day, ventilation, and light* also can have impacts on physical or psychological responses.

## 2 Physical Modifying Factors.

- a. *Fatigue* may be induced by lack of sleep, monotony, rhythm of travel, rarified atmosphere at high altitudes, as well as by carbon monoxide (CO) emissions from faulty exhausts. It increases reaction time.
- b. *Disease and physical disability* is usually compensated for, but tends to cause more intense emotional reaction.
- c. *Drugs* have various effects (Ref. 5). There is no evidence of adverse effects caused by narcotics or amphetamines, but tranquilizers, marijuana, and barbiturates seem to impair performance.
- d. *Alcohol* impairs alertness, reaction time, quality of judgment, and physical coordination as levels of alcohol in the bloodstream increase. Pedestrian capabilities are also adversely affected.
- e. *Age* reduces response time. Ref. 3 (v. 2, p. 275) reports that two studies found the response time of elderly drivers to be about 10% or 50 milliseconds longer than the average values for all drivers.

## 3 Psychological Modifying Factors.

- a. *Intelligence level* determines the speed and accuracy with which information is processed and decisions are reached.
- b. *Maturity*. Immature drivers, tend to show off, take chances, or seek thrills.
- c. *Attentiveness*. Drivers may be distracted by events outside or inside the vehicle:
  - (1) *Outside* distractions include events not related to the driving situation on the street, the sidewalk, or road shoulder, even in the sky (sudden inclement weather, advertising signs).
  - (2) *Inside* distractions include conversation (with passengers or on a cell phone), personal care (shaving or applying makeup while driving), programs on the car stereo, map reading, or using in-vehicle navigation systems.
- d. *Attitudinal factors*:
  - (1) *Attitude toward risk*. We accept a certain level of risk in all we do. There is evidence that some individuals respond to an increasingly safer environment (whether real or apparent) with riskier behavior ("risk homeostasis"). For example, some pedestrians overestimate the protection afforded by painted crosswalks and may enter them with less care than they use at unpainted crosswalks (Ref. 6).
  - (2) *Attitude toward regulation*. Some persons obey all laws and signs literally, however unreasonable. Others have little or no respect for traffic laws. Most, however, are susceptible to reasonable regulations and enforcement, will interpret laws and signs in a reasonable manner, and will adapt to unusual situations.
  - (3) *Impatience and anger ("road rage")*. This attitude may result in driving above the safe speed for prevailing conditions, unnecessary or dangerous weaving and overtaking, running through red signal indications or STOP signs, following too closely, "jay-walking," or other risky or irrational acts.

- 4 **Individual differences.** An individual's behavior cannot be predicted with any degree of certainty. It can only be estimated from a distribution of behavior patterns obtained from an appropriate study.

Motor vehicle departments have sought, without success, to identify factors that could be used to reject applicants expected to be poor drivers. However, one study of habitual violators could not ascribe this tendency to any particular factor (Ref. 7). Even if such work were to succeed, the prior constraint aspects would make it subject to challenge in court.

## E. Special Categories

### 1 The Transportation Disabled.

Special consideration must be given to, and provisions made for, the transportation disabled. The 2001 National Household Transportation Survey (Ref. 8) estimated that they comprise 16.5 million people, or 6% of the U.S. population. Of the total population aged 65 and over, 7.5 million or 22.5% are transportation disabled. Table 3-1 shows how they respond to their condition.

**Table 3-1—Disabled Persons' Responses—U.S., 2001**

	Percent of Total Population		
	<65 yrs	65+ yrs	All
All transport disabled	3.7%	22.5%	6.0%
Reduced day-to-day travel	3.5%	20.1%	5.5%
Asked others for a ride	2.5%	12.7%	3.7%
Limited driving to daytime	1.5%	10.5%	2.6%
Given up driving altogether	0.6%	7.8%	1.5%
Used bus/subway less frequently	0.8%	3.9%	1.2%
Used special transport services	0.5%	2.9%	0.8%

Source: Ref. 8.

Percentages do not add; persons gave more than one answer.

### 2 The Elderly.

"Elderly drivers show an increased effort of self-protection in their driving habits relative to mid-aged drivers (persons between the ages of 25 and 64 years). Being elderly not only makes elderly drivers reduce daily driving exposure, avoid driving at night, avoid driving during peak hours, and avoid driving on limited-access highways, but also makes them drive at lower speeds, drive larger automobiles, and carry fewer passengers. Despite their effort of self-protection, however, the elderly still show a higher risk of crash and injury per unit of exposure than the mid-aged. If policies induce the elderly to further adjust their driving habits to offset the external risks of their driving, their risk of crash and injury would be reduced and society as a whole would be better off. The elderly, however, are likely to be worse off as a consequence of reduced mobility. The challenge to policy-making is to balance these consequences of any policy concerning the mobility and traffic safety of the elderly." (Ref. 9)

Table 3-2 shows the proportion of the elderly that do not have drivers' licenses, and are therefore dependent on other modes of transportation.

**Table 3-2—Elderly Population Without Drivers' Licenses**

Age Group	Male (%)	Female (%)	Total (%)
65 - 69	3.4	15.6	9.9
70 - 74	5.5	21.3	14.3
75 - 79	6.6	27.9	18.6
80 - 84	9.7	37.4	26.9
85 and over	18.5	59.9	48.3

Source: U.S. FHWA. Highway Statistics 2003, Table DL-20, Oct. 2004.

## F. Systems Failure and Unavailability

Human factors are often, but not always, involved when a transportation system or one of its components ceases to function normally. The response to such a failure or planned shutdown (as for maintenance) almost always involves human judgment, often in a rapid way as in a control center. However, computer control systems are becoming more "intelligent" and are increasingly programmed to respond to system degradation by modifying instructions to controls, such as signals and changeable message signs.

### 1 Definition of "Failure."

- a. Complete breakdown or unavailability of a component, a link, a node, part of a network, or an entire system. For example, a bridge has collapsed.
- b. Partial breakdown or unavailability means performance is somewhat degraded. For example, if a traffic signal system loses power, vehicles can continue to move, but must enter intersections at low speeds or after stopping.
- c. Failure may not affect the entire public equally, if at all; e.g., only some drivers selected at random are stopped at a police checkpoint for "Driving Under the Influence" (DUI); an overhead bridge is being built and the falsework requires that tall trucks detour around the site, but others can proceed.

### 2 Causes of Unavailability.

- a. Physical causes include:
  - Infrastructure or vehicle failure.
  - Power supply failure.
  - Natural disasters or events: snow and ice, floods, landslides, earthquakes, and the like.
  - Maintenance requirements.
- b. Failure in communications or in human performance, leading to an accident. Examples include:
  - Traffic control device missing or malfunctioning.
  - Driver blinded by sun or DUI.
- c. Sudden, usually unexpected increase in demand, leading demand to exceed capacity.
- d. Institutional causes include:
  - Police checkpoint for DUI drivers, undocumented aliens, etc.
  - Labor strikes or employer lockouts.
  - Bankruptcies.
  - Shutdown of unprofitable operations (e.g., at night, on weekends).

### 3 Degradation. Can be sudden or gradual.

### 4 Recovery Time. How much time is needed to check and correct the problems of the inoperative system or components before recovery can commence? For example, does spilled diesel fuel at the site where a truck overturned have to be removed from the road surface before traffic is allowed to enter the area?

### 5 Predictable or Unpredictable. Examples are shown in Table 3-3.

### 6 Planning Ahead to Maintain Supply and/or Reduce Demand.

- a. Maintain supply by means of
  - Detours to parallel facilities, alternate routes, alternate modes.
  - Bypasses on shoulder; crossovers to other roadway on divided highway.
  - Stand-by equipment and personnel.
- b. Reduce demand by
  - Early warnings by signs, information to media, etc., if predictable.
  - Emergency broadcasts, changeable message signs, etc. if unpredictable.
- c. Disaster plans to manage sudden changes.

Some of these "solutions" will be discussed in later chapters.

**Table 3-3—Examples of Predictable and Unpredictable “Failures”**

	Predictable	Unpredictable
During construction	Need for working space requires detours, etc.	Failure of construction method; shortage of supplies; strikes.
During normal operations	Repetitive congestion.	Power, vehicle, or infrastructure failure; accidents; strikes (e.g., public transport)*, protest marches; natural disasters*.
Programmed maintenance or surveillance	Lane or facility closure for work; police checkpoint.	None by definition.
Special events (e.g., parades)	Road closure for event; congestion caused by event.	Unexpected escalation of event.

\* - Some of these events may be predictable in a short time frame.

## G. Motor Vehicle Characteristics

The characteristics and performance capability of motor vehicles play a major role in defining the tasks of traffic engineering. Dimensions determine geometric and structural design of highways and parking facilities. Performance, considered in conjunction with drivers' use of these performance capabilities, determines the characteristics of traffic flow and safety.

### 1 Dimensions.

- a. Length, width, and height are restricted by law so that motor vehicles will fit geometric standards of the highway system. Trucks and buses of maximum legal dimensions are common, and there is constant pressure for raising these limits. State laws are far from uniform. The Surface Transportation Assistance Act (STAA) of 1982 set minimum dimensions and maximum weights on Interstate and "designated" (I-D) highways; the latter are additional intercity truck routes and connections to truck terminals to be designated by the states and approved by US DOT. Passenger car dimensions are well below legal limits, but are of concern when designing parking facilities. Ref. 10 has data for passenger vehicles.
  - (1) *Length*: Off the I-D highway network, maximum lengths allowed in most states are 12.2 m [40 ft]\* for single unit trucks and buses, 16.2 m [53 ft] for semitrailers, 18.3 m [60 ft] for truck-semitrailer combinations, and 19.8 m [65 ft] for truck-plus-trailer combinations. In those states that specify articulated bus lengths, the maximum is 18.3 m [60ft] in most cases.
  - (2) *Width*: Almost all states set the maximum width of vehicles at 2.6 m [8.5 ft].
  - (3) *Height*: Almost all states set maximum height at either 4.1 m [13.5 ft] or 4.3 m [14.0 ft].
- b. *Turning radii and rear-wheel tracking paths* determine the minimum radii used in the design of short-radius curves, channelization, and parking facilities. See Fig. 18-1 for typical paths of front and rear wheels.
- c. *Underclearance* is important in designing vertical curves at driveways and on parking ramps. These characteristics change with the design of vehicles.
- d. The *weight* of vehicles is limited to fit the structural standards of pavements and bridges. Weight limits are usually specified both per wheel and per axle, with spacing between adjacent axles a factor for vehicles of three or more axles. Again, there is no uniformity among the states, but many states follow the STAA maxima for the Interstate System:
  - (1) Maximum weight per axle = 9.1 t [20,000 lb].
  - (2) Maximum weight per tandem axles = 15.4 t [34,000 lb].
  - (3) Maximum total gross weight = 36.3 t [80,000 lb].

However, the increasing use of high-pressure radial tires with their smaller contact area has not been regulated and is beginning to cause considerably faster pavement wear and rutting.

\* - Because federal and state laws are written using British units, these values are here shown in brackets.



## 2 Performance.

- a. *Power* defines the ability of vehicles to accelerate, maintain speed, and climb grades. There are no regulations specifying either the maximum power plant permissible or a minimum power-to-weight ratio; the former has at times been suggested as a speed control measure; the latter would provide for minimum capabilities of heavy vehicles on grades or when accelerating.
- b. *Acceleration rates* for passenger cars on level roads are normally about 1.4 - 1.8 m/s<sup>2</sup> up to 65 km/h and decrease at higher speeds. However, maximum possible acceleration, determined by the power-to-weight ratio and the friction between tires and pavement, can be twice these rates. Heavy trucks and truck-trailer combinations can accelerate at no more than about 0.9 m/s<sup>2</sup> on level roads.

The effect of grades on maximum possible acceleration rates is shown in Table 6-46 and Fig. 6.12 of Ref. 11. When accelerating from a stop, the typical passenger car's maximum capability is 3.6 m/s<sup>2</sup> on level roads, 3.0 m/s<sup>2</sup> on a 6% uphill grade, and 2.6 m/s<sup>2</sup> on a 10% uphill grade. For large trucks these rates are, of course, less, and many cannot reach speeds of more than 25 km/h on sustained grades of about 6%.

- c. *Deceleration rates*: Ninety percent of drivers decelerate at a rate of 3.4 m/s<sup>2</sup> or greater (Ref. 4). Deceleration with locked wheels may reach about 0.9g or 8 m/s<sup>2</sup>. The deceleration rate is rarely uniform throughout a skid, although it is often assumed to be so in accident analysis.
- d. *Braking*. When a vehicle decelerates, it loses kinetic energy. If cruising, the loss is caused by frictions of various vehicle components and, perhaps, by wind resistance or by moving uphill. When brakes are applied, energy is expended by the friction within the brakes. If wheels lock, the skidding friction (described in Part G. below) absorbs most of the kinetic energy. Antilock braking systems (ABS) or careful braking can avoid wheel locking and, to a limited extent, can increase the deceleration rate. For safety analysis purposes, however, the wheel-locking situation must be assumed.

Hybrid (gasoline-electric) vehicles regenerate some of the "lost" kinetic energy and use it to recharge the battery pack that drives the electric motor. Besides increasing fuel economy, this process also reduces wear on the brakes. (See Chap. 34.)

Minimum brake performance standards are specified by Federal Motor Vehicle Safety Standard No. 105 (Ref. 12).

- e. *Fuel economy* is discussed in Chap. 32. (See also Table 2-5 in Chap. 2.)

- 3 **Motorcycles.** (Data from Ref. 13.) The number of motorcycles in the U.S. increased rapidly from 454,000 in 1950 to 5.7 million in 1980. Data from registration records show a decline in the 1980s to a level of about 4.3 million in 2000.

The rapid increase in motorcycle fatalities from 730 in 1960 to 5,140 in 1980 caused the issuance of Motor Vehicle Safety Standards Nos. 122 and 123, covering motorcycle brakes, controls, and displays (Ref. 12). Motorcycle fatalities thereupon decreased to around 2,200 per year in the mid-1990s, but have risen to 3,660 in 2003.

- 4 **Bicycles.** (See Chap. 21.)

- 5 **Safety Standards.** From enactment of the Motor Vehicle Safety Act of 1966 to October 2003, the federal government promulgated 59 safety standards covering various vehicle components, accessories, and fuels (Ref. 12). (See Chap. 33.)

## H. Skidding and Stopping Distances

- 1 **Basic Equation for Constant Deceleration.** The distance traveled by a vehicle while decelerating (or accelerating, for that matter) at a constant rate is:

$$d = \frac{u_1^2 - u_2^2}{2 \bullet w} \quad \text{or} \quad d = \frac{U_1^2 - U_2^2}{25.92 \bullet w} = 0.039 \frac{U_1^2 - U_2^2}{w} \quad [3.1]$$

where

$d$	=	distance traveled in m
$u_1^2, u_2^2$	=	initial and final speeds of vehicle, respectively, in m/s.
$U_1^2, U_2^2$	=	initial and final speeds of vehicle, respectively, in km/h.
$w$	=	rate of deceleration (or acceleration) in $\text{m/s}^2$

Actually, rates of change of speed are not constant, but are usually assumed to be so for the purpose of this type of analysis. Typical deceleration rates are shown in G.2.c. above.

- 2 **Skidmark Analysis.** When faced by sudden emergencies, drivers almost invariably brake so suddenly that they cause the brakes to lock the wheels and the vehicle to skid. The kinetic energy of the vehicle—proportional to the square of the speed—is dissipated through friction work generated where the tires contact the pavement. The heat generated melts some rubber, which appears on the pavement in the form of skidmarks. When skidmarks are found at the scene of an accident, they can often be used to calculate the probable initial speed of vehicles.

The deceleration rate ( $a$ ) is determined by this friction and is expressed by the term  $f \bullet g$  in Eq. [3.2] for level roads; a correction factor for grades is given in H.3.d.

$$d = \frac{u_1^2 - u_2^2}{2 \bullet f \bullet g} \quad \text{or} \quad d = \frac{U_1^2 - U_2^2}{25.92 \bullet f \bullet g} = 0.039 \frac{U_1^2 - U_2^2}{f \bullet g} \quad [3.2]$$

where

$f$	=	average friction or drag factor (see H.3. below)
$g$	=	rate of acceleration due to gravity ( $9.805 \text{ m/s}^2$ )

Since speeds used in this analysis are usually in km/h, Eq. [3.2] with the value for  $g$  substituted becomes:

$$d = \frac{U_1^2 - U_2^2}{254 \bullet f} \quad \text{and} \quad U_1 = \sqrt{254 \bullet f \bullet d + U_2^2} \quad [3.3]$$

If the vehicle comes to a halt at the end of the skid,  $U_2 = 0$ . Then

$$d = \frac{U_1^2}{254 \bullet f} \quad \text{and} \quad U_1 = \sqrt{254 \bullet f \bullet d} = 15.94 \sqrt{f \bullet d} \quad [3.4]$$

The skidmarks only indicate the distance through which a vehicle decelerated by skidding. Deceleration generally also takes place

- before the wheels lock; in fact, skidding is a less efficient method of reducing vehicle speed than applying the brakes to a point just before the wheels lock, or when an ABS is available. The amount of deceleration taking place before the skidmarks begin to be laid down depends on the rate at which the brakes were applied;
- after the skidmarks end, if the brakes are released and the vehicle is permitted to roll to a stop;
- after the skidmarks end, if the vehicle hits another vehicle or an object. The kinetic energy remaining in the decelerating vehicle at the point of impact is converted into movement of the vehicle or object hit, and/or is absorbed by deformation of the colliding objects;

- after the skidmarks end, if the vehicle rolls over. Generally, evidence in the roadway will indicate the distance a vehicle skidded on its side or roof, and estimates can be made of the speed of the vehicle at the time it rolled over;
- during gaps in skidmarks (e.g., if some wheels temporarily unlock or leave the ground in short skips).

3 **Coefficient of Friction and Drag Factor.** The coefficient of friction is the ratio of the friction (retarding) force developed by a skidding wheel and the weight the wheel exerts on the pavement. This coefficient often varies from wheel to wheel in a skid, and changes as the skid progresses; its average value for the entire skid is called the drag factor.

Coefficients of friction vary widely. Fig. 3-2 illustrates the range of coefficients obtained in experiments, but these should be used with caution, especially the extrapolations. See also Ref. 15 and Exhibit 9-5 of Ref. 16; values given in both are also only approximate.

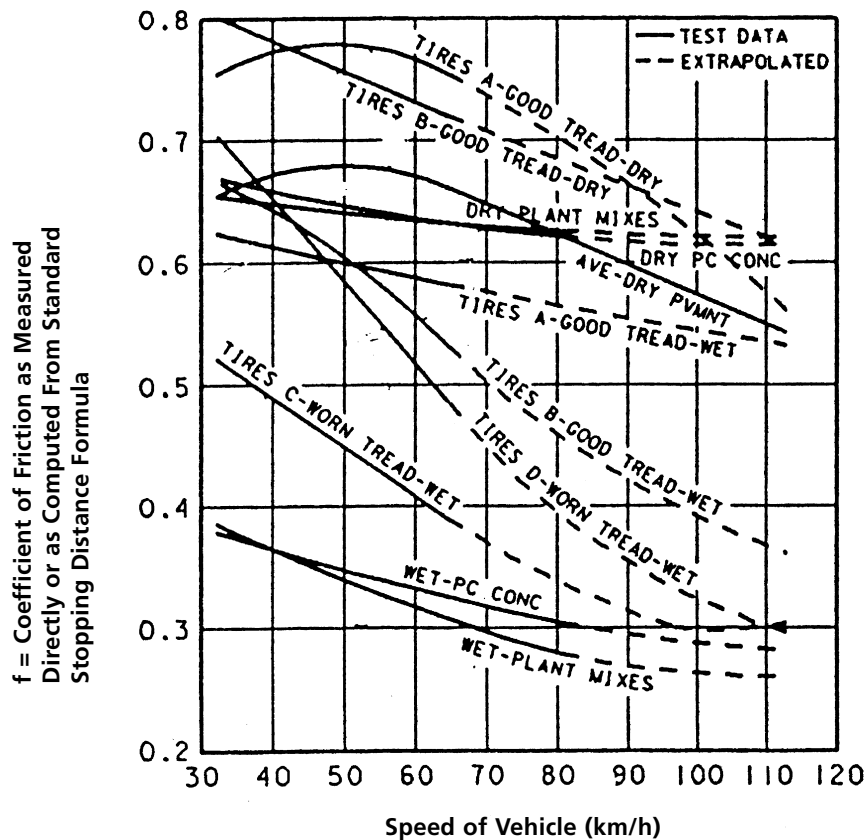

Fig. 3-2—Examples of Friction Factors

Source: A Policy on Geometric Design of Highways and Streets. Washington, DC: The American Association of State Highway and Transportation Officials, Copyright 1994. Used by permission.

Conditions that cause variations in friction coefficients include:

- a. *Road Surface Factors* include:
  - (1) Surface condition (i.e., dry, wet, snow- or ice-covered)
  - (2) Surface construction (i.e., type, method, material, texture)
  - (3) Surface maintenance and contamination by foreign materials
  - (4) Effects of scouring, weathering, time, traffic, and age
  - (5) Ambient temperature, pavement, and tire tread.
  - (6) Geometric design features.

b. *Vehicle Operating Factors.*

- (1) Initial vehicle speed. As skidding continues, friction coefficients usually drop since tires develop heat and smooth contact areas. Hence, long skids have lower drag factors than short skids, other conditions being equal.
- (2) Vehicle size and weight distribution.
- (3) Type of braking, cornering, side-skidding, or sliding.

c. *Tire Factors.*

- (1) Size, tread pattern, plies, cord angle, and related design factors.
- (2) Load, contact area, and inflation pressure.

d. *Grade.* Allowance for grade may be made by adding the grade, expressed as a decimal (uphill positive, downhill negative) to the drag factor. However, since the tabulated drag factors are only approximate, little accuracy is gained by correcting for grades of less than 3%. If the drag factor is obtained by a test skid on the same road in the same direction as the accident skid, the effect of the grade will automatically be included, and no correction is applied.

- 4 **Test Skids to Obtain Drag Factors.** Accurate values for drag factors for a specific place, vehicle, and surrounding conditions can be obtained only by means of a field test. For example: a test car is skidded from a speed of 50 km/h to a halt; the resulting average length of skid-marks is 16 m. Inserting in Equation [3.4]:

$$d = \frac{U_1^2}{254 \bullet f}; \quad \therefore 16 = \frac{50^2}{254 \bullet f} \text{ or } f = 0.62$$

If a test skid is made, the value of  $f$  need not be computed to estimate the speed of another vehicle A that skidded to a halt on the same pavement under similar wetness and similar tire conditions.

For the test skid (from Eq. [3.4]): 
$$U_t = 15.94\sqrt{f \bullet d_t} \quad [3.5a]$$

And for the skid of vehicle A: 
$$U_a = 15.94\sqrt{f \bullet d_a} \quad [3.5b]$$

Dividing Eq. [3.5a] by Eq. [3.5b]: 
$$\frac{U_t}{U_a} = \sqrt{\frac{d_t}{d_a}} \quad [3.5c]$$

For example, if the test skid described above is made at the site where vehicle A skidded 52 m, then

$$U_t = 50, \quad d_a = 16, \quad d_t = 52$$

$$\frac{50}{U_a} = \sqrt{\frac{16}{52}}, \text{ or } U_a = 50\sqrt{\frac{52}{16}} = 90.1 \text{ km/h}$$

However, if vehicle A did not skid to a stop, this shortcut cannot be used, and  $f$  must be computed.

- 5 **Accuracy of Speed Computations.** The results obtained by computing speeds from skid-marks using the equations discussed here will:

- a. almost always be lower than the speed of the vehicle before it started decelerating, because the computations ignore the amount of deceleration prior to skidding.
- b. be fairly accurate if the skidding does not end in impact or ends in impact at low speed and if the drag factor is obtained by test skids at the scene.

- c. be less, but still acceptably, accurate if the skidding does not end in impact or ends in impact at low speed, and if the drag factor is obtained from a reference table.
- d. may be accurate or inaccurate if the skidding ends in impact at high speed, depending on the quality of the estimate of speed at the moment of impact.
- 6 **Safe Stopping Distance.** When computing the safe stopping distance, Eqs. [3.1] and [3.2] must be modified to include the distance traveled by a vehicle at the initial speed before the brakes are applied, i.e., during the perception-response time (PRT). Since the final speed is zero, the safe stopping distance is:

$$\text{No skidding} \quad d = u_1 \bullet T_{PR} + \frac{u_1^2}{2 \bullet w} \quad \text{or} \quad d = 0.28 \bullet U_1 \bullet T_{PR} + \frac{U_1^2}{25.9 \bullet w} \quad [3.6a]$$

$$\text{With skidding} \quad d = u_1 \bullet T_{PR} + \frac{u_1^2}{19.6 \bullet f} \quad \text{or} \quad d = 0.28 \bullet U_1 \bullet T_{PR} + \frac{U_1^2}{254 \bullet f} \quad [3.6b]$$

where  $T_{PR}$  is the PRT (see Part D above).

- 7 **Example of Computing Speed, Involving Two Different Pavement Surfaces.** Suppose a car is known to have skidded on a bituminous surface, then on the adjacent gravel shoulder where it finally came to a halt. The average length of skidmarks on the bituminous surface ( $d_b$ ) is 36 m, on the gravel shoulder ( $d_g$ ) 12 m. What was the speed of the vehicle at the beginning of the skid?

From test skids or reference tables, the drag factor for the bituminous surface ( $f_b$ ) and gravel ( $f_g$ ) are found to be 0.50 and 0.60 respectively. If the speed at the beginning of the gravel portion of the skid is  $U_1$ , then

$$U_1^2 = 254 \bullet f_g \bullet d_g = 254 \bullet 0.60 \bullet 12 = 1828.8$$

$$U_1 = 42.8 \text{ km/h}$$

If the speed at the beginning of the bituminous portion of the skid is  $U_2$ , then

$$U_2^2 = 254 \bullet f_b \bullet d_b + U_1^2 = 254 \times 0.50 \times 36 + 1828.8 = 6400.8$$

$$U_2 = 80 \text{ km/h}$$

- 8 **Further Study.** For a comprehensive treatment of this subject, see Ref. 15.

#### REFERENCES

1. Bailey, Robert W. *Human Performance Engineering*. 3rd Ed. Upper Saddle River, NJ: Prentice-Hall PTR, 1996, 636 p.
2. Allen, Merrill J. *Vision and Highway Safety*. Philadelphia: Chilton Book Co., (Principles of Optometry Series, Vol. 11) 1970, 253 p.
3. Transportation Research Board. *Transportation in an Aging Society: Improving Mobility and Safety for Older Persons*. Washington, DC: Special Report 218, 2 vols. 1988.
4. Fambro, Daniel B. et al. "Determination of Stopping Sight Distances." *National Cooperative Highway Research Program Report 400*, 1997. 84 p. + Appendix.
5. Weintraub, L. "Drugs and Alcohol Affection Highway Safety." In: *Forensic Aspects of Vision and Highway Safety*. Tucson, AZ: Lawyers & Judges Publishing Co., Inc. 1996. Chap. 15.
6. Herms, B. F. "Pedestrian Crosswalk Study: Accidents in Painted and Unpainted Crosswalks." *Pedestrian Protection*. Washington, DC: Highway Research Record 406. 1972, pp. 1-13.

7. Case, Harry W., et al. "The Habitual Traffic Violator." *Traffic Accidents and Violations*. Highway Research Bulletin 120. Washington, DC: Highway Research Board, 1956, pp. 31-36.
8. Liss, S., et al.. *Our Nation's Travel: Current Issues*. **DRAFT**. 2001 National Household Travel Survey. Washington, DC: USDOT, FHWA, Internet, Dec. 2004. Available at [http://nhts.ornl.gov/2001/ONT\\_Draft.pdf](http://nhts.ornl.gov/2001/ONT_Draft.pdf)
9. Chu, X..The Effects of Age on the Driving Habits of the Elderly. [Quote from the Abstract.] Tampa, FL: Center for Urban Transportation Research. University of South Florida. 1994. Online at [http://ntl.bts.gov/card\\_view.cfm?docid=5570](http://ntl.bts.gov/card_view.cfm?docid=5570)
10. *Automotive News - Market Data Book*. Special annual number issued in May.
11. French, A. "Vehicle Operating Characteristics". In: *Transportation and Traffic Engineering Handbook*, 2nd Ed., Englewood Cliffs, NJ: Prentice Hall, 1982, pp. 162-175.
12. U.S. Government. *Code of Federal Regulations*. Title 49, Part 571. Oct. 1, 2003.
13. U.S. Bureau of Transportation Statistics. Table 2-22. Oct. 2004, Available at [http://www.bts.gov/publications/national\\_transportation\\_statistics](http://www.bts.gov/publications/national_transportation_statistics).
14. Moyer, R. A. "A Review of the Variables Affecting Pavement Slipperiness." *Proceedings, Part II, First International Skid Prevention Conference*. Charlottesville, VA: August 1959, pp. 411-433.
15. Limpert, R. *Motor Vehicle Accident Reconstruction and Cause Analysis*. Charlottesville, VA: Lexis Publishing,. 5th Ed., 1999. Chapter 20.



## A. Introduction

Traffic streams result from the aggregation of individual vehicles or pedestrians moving along the same path in the same direction. The stream parameters are defined by the capabilities and predilections of the drivers and pedestrians (i.e., human factors), the performance characteristics of vehicles, and the geometric—and, to a lesser extent, surface quality—properties of the roadway. (Although the rest of this chapter focuses on motor vehicle traffic, there are similarities to pedestrian and bicycle traffic movement.)

The physical fact of finiteness and the principle of conservation underlie traffic stream behavior; however, they are modified by ambiguity resulting from variations in human behavior. It becomes possible to predict the average behavior and variances about such an average for a traffic stream, but never the precise behavior of an individual element within the traffic stream.

- 1 **Finiteness.** Vehicles are finite objects, no two of which can simultaneously occupy the same space without unpleasant results. In normal operation, drivers do not encroach upon an "envelope" around other vehicles, leaving both longitudinal and lateral space. For safety and comfort, drivers desire a generous envelope at high speeds; when increasing traffic reduces the size of such an envelope, drivers will slow down. They may refer to this condition as "congestion," although this chapter (and Chap. 8) will use more technical terminology and more precise analysis.

Also, motor vehicles have finite performance characteristics (see Chap. 3) which may prevail regardless of the desires of drivers. Finally, roadway geometrics—horizontal and vertical alignment, junctions, and marginal frictions—define upper limits on safe speeds.

- 2 **Conservation.** Road users neither appear from nowhere nor disappear into oblivion. They can only join traffic streams at trip origins or at junctions and can leave them only at trip destinations or at other junctions.
- 3 **Ambiguity.** Control over motor vehicles on a roadway rests with individual drivers. Within certain constraints, primarily the avoidance of collisions with other users, drivers are free to change their speeds and positions relative to these other users. There is compelling evidence that the average behavior of groups of drivers may be estimated, but that of any random individual cannot be predicted with any degree of confidence.

The practicing traffic engineer is concerned with alleviating problems arising from the fundamental properties of road traffic. This chapter will briefly describe some of the basic characteristics of groups of vehicles moving in the same direction along a finite length of road or intersecting each other at road junctions.

Some transportation scientists have sought to describe traffic streams by fitting mathematical models to data obtained in the field. Others have attempted to analyze the complexities of these



streams by drawing analogies with the flow of liquids, telephone messages, or other inanimate commodities where flow conditions can be rigidly controlled. As this discussion suggests, neither of these approaches can be expected to produce more than a very approximate description of traffic stream behavior.

*Traffic Flow Theory* is a related but more comprehensive subject that will not be dealt with here. The traffic engineer seeking an introduction to this topic will find Ref. 1 a good starting point. The subject is discussed in a more advanced manner in Ref. 2.

## B. Some Definitions and Fundamental Concepts

1 **Basic Parameters and Their Definitions.** Traffic streams are analyzed in terms of three basic parameters and their reciprocals (Table 4-1). While various sources may use slightly different terminology and symbols, the following definitions (taken primarily from Ref. 2) are those most commonly found in the literature.

**Table 4-1—Basic Traffic Stream Parameters**

Parameter	Symbol	Typical Units	Reciprocal	Symbol	Typical Units
Flow	$q$	veh/h	Headway	$h$	s/veh
Speed	$u$	km/h	Travel time	$T$ †	min/km
Density	$k$	veh/lane•km	Spacing	$s$ †	m/veh

† -No one symbol is in standard use; T is also used to denote moments in time; s is also used to denote the standard deviation of a distribution.

### *Flow and Headway*

- $q$  = flow: the number of vehicles passing a point per unit of time; often called volume when the time unit is one hour.
- $q_m$  = the maximum attainable flow under existing road conditions.
- $h$  = headway: the time interval between passage of consecutive vehicles moving in the same stream, measured between corresponding points (e.g., front tires) of successive vehicles.
- $g$  = gap: the time interval between the passage of consecutive vehicles moving in the same stream, measured between the rear of the lead vehicle and the front of the following vehicle.

### *Speed and Travel Time*

- $u$  = speed: the time rate of change of distance,  $dx/dt$ .
- $\bar{u}_t$  = time-mean speed or spot speed: the arithmetic mean of the speeds of vehicles passing a point during a given time interval. (See Chap. 6.)
- $\bar{u}_s$  = space-mean speed: the arithmetic mean of speeds of those vehicles occupying a given length of road at a given instant. (See Chap. 6.)
- $\bar{u}_m$  = the space-mean speed at maximum flow ( $q_m$ ).
- $T$  = travel time. (See Chap. 7 for further discussion.)

### *Density and Spacing*

- $k$  = density: the number of vehicles occupying a road lane per unit of length at a given instant.
- $k_m$  = the density at maximum flow ( $q_m$ ).
- $k_j$  = maximum or jam density: the density when  $u$  and  $q$  are zero.
- $s$  = spacing: the distance between vehicles moving in the same lane, measured between corresponding points (front to front) of consecutive vehicles.

*Queueing Analysis Functions*

$A(t)$  = The cumulative number of vehicle arrivals as a function of any time  $t$ .

$D(t)$  = The cumulative number of vehicle departures as a function of  $t$ .

$Q(t)$  = The length of a queue at time  $t$ .

$W(t)$  = The waiting time of a vehicle in a queue that arrives at time  $t$ .

**2 Types of Flow.**

- a. Uninterrupted: vehicles traversing a length of road are not required to stop by any cause external to the traffic stream, such as traffic control devices.
- b. Interrupted: flow is periodically interrupted by external features, primarily traffic controls.

**3 Types of Congestion.** Uninterrupted traffic subject to internal disturbances. Congestion of uninterrupted traffic can be classified into two types:

- a. Recurrent congestion, that occurs repeatedly at the same place (upstream of a bottleneck) and time of day, e.g., every weekday morning or every summer Sunday.
- b. Nonrecurrent congestion, that is the result of some one-of-a-kind event, such as an accident, disabled vehicle, or road closure.

**4 Time-Space Trajectories.** Diagrams showing the trajectories in time and space of individual vehicles (or vehicle platoons in the case of signal timing diagrams—see Chap. 16) for the purpose of understanding some aspects of traffic stream behavior.**5 Bottleneck.** Any location at which either a reduction in  $q_m$  (e.g., due to a lane drop or a traffic signal) or an increase in demand (e.g., at an on-ramp or shopping center driveway) causes demand to equal or exceed capacity. Bottlenecks are usually fixed locations, but slow-moving vehicles that cause queues behind them are sometimes also referred to bottlenecks.**6 Queue.** An accumulation of vehicles upstream of a bottleneck. The term is used when the vehicles are standing still ( $q = 0$ ,  $u = 0$ ,  $k = k_j$ ) or when moving slowly.**7 Platoon.** In *uninterrupted* traffic, a group of vehicles travels at the speed set by the "leader"—a slower vehicle—rather than at the speeds preferred by the individual drivers. This situation occurs most often on rural two-lane highways where passing opportunities are limited, or on upgrades on multilane highways where high flows make lane changing and overtaking difficult. It may be thought of as a queue behind a moving bottleneck.

In *interrupted* traffic, a group of vehicles travels together on an arterial after assembling at a signalized intersection during a red interval.

**C. Uninterrupted Traffic****1 Fundamental Traffic Stream Equation.** Flow is the product of speed and density. For *uninterrupted* traffic streams the equation is:

$$q = \bar{u}_s \cdot k \quad [4.1]$$

In the field, density is more difficult to measure directly than speed and flow; this formula permits its calculation if simultaneous flow and space-mean speed data are available (See Chaps. 5 and 6).

**2 Speed, Flow, and Density.** Figs. 4-1(a), (c), and (d), derived from Figs. 7-1 and 7-2 of the *Highway Capacity Manual* (Ref. 3), show the relationships among speed, flow, and density likely to be found on multilane highways under ideal conditions. In Fig. 4-1(a) an indication of the 10th and 90th percentile speeds (see Chap. 6 for details on speed distributions) is shown to illustrate that at all flows up to the maximum ( $q_m$ ) individual drivers have varying degrees of freedom to choose their own speeds, an illustration of the "ambiguity" property of road traffic. The space-mean speed, required for solution of Eq. [4.1], is also plotted in Fig. 4-1(a) and in Fig. 4-1(c).

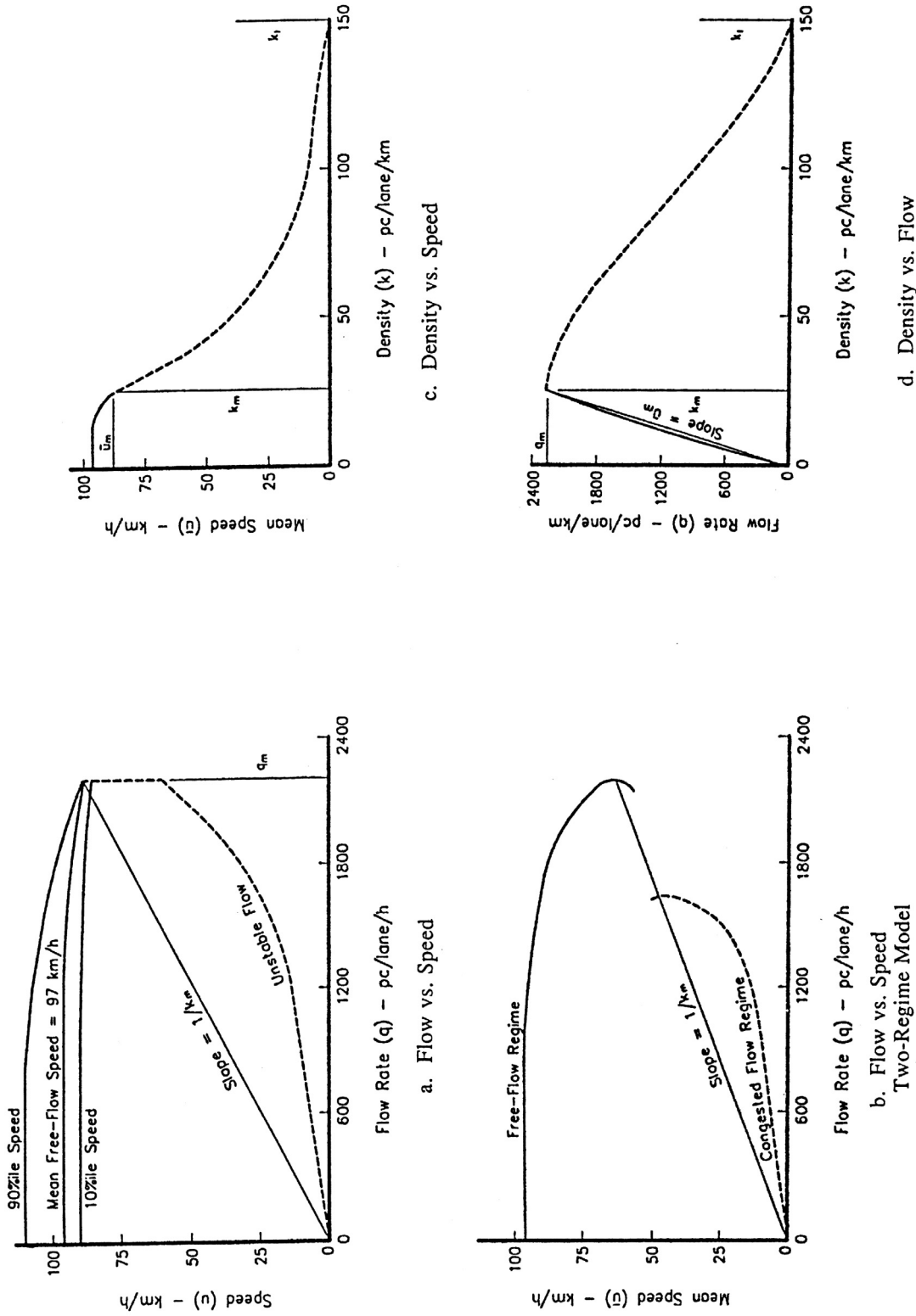

Fig. 4-1 - Basic Speed-Flow-Density Relationships for Uninterrupted Flow.

**Table 4-2—Flow Rates, Speeds, and Densities for Different Levels of Service**

Level of Service	Maximum Service Flow Rate pc/lane/h	Average Speed km/h	Maximum Density pc/lane/km
A	700	100.0	7
B	1100	100.0	11
C	1575	98.4	16
D	2015	91.5	22
E	2200	88.0	25

Source: Ref. 3, Exh. 21-2.

Table 4-2 lists numerical values obtained from Ref. 3. Levels of Service (LOS) are defined and described in Chap. 8, Sec. B. LOS F is not shown in Table 4-2 because it is characterized by highly unstable and variable values for the traffic flow parameters. The dashed portions of the curves in Fig. 4-1 provide general representations of LOS F conditions.

The relationships shown in Fig. 4-1 (a), (c), and (d), and used in Ref. 3 are classified as *single-regime models*. However, some researchers have shown that there are at least two regimes—one for free flow and one for congested flow—and that there is a discontinuity in each of the three curves in the region of capacity. Fig. 4-1(b) shows how a two-regime model corresponding to Fig. 4-1(a) would appear. Multi-regime models are discussed in Chap. 10 of Ref. 2.

- 3 **Flow at Bottlenecks.** Congestion occurs in uninterrupted traffic flows when more vehicles enter the upstream end of a section of road than can get out of the downstream end, e.g., if one lane is dropped from a freeway as in Fig. 4-2.

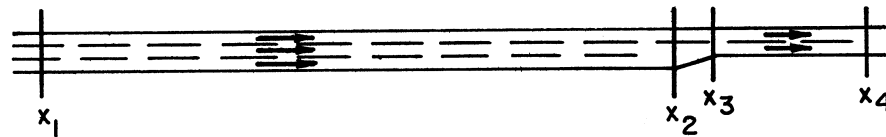
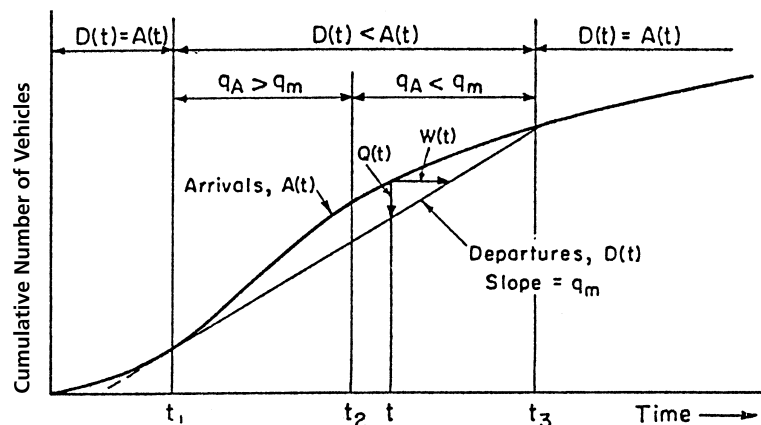

**Fig. 4-2—Schematic Diagram of a Bottleneck**

The behavior of traffic in the vicinity of this bottleneck can be analyzed by plotting:

- a. the cumulative number of vehicles arriving at a point a considerable distance upstream (e.g.,  $x_1$  in Fig. 4-2), describing a cumulative arrival function  $A(t)$ , and
- b. the cumulative number of vehicles passing through the bottleneck, as measured at  $x_2$ .

In this simple example, vehicles cannot pass  $x_2$  at a rate greater than  $q_m$ , the maximum flow rate attainable on the section between  $x_3$  and  $x_4$ ; as a result, the slope of the departure function,  $D(t)$ , cannot be greater than  $q_m$ . Thus,  $D(t)$  can be approximated by drawing a straight line with slope  $q_m$  tangent to the arrival curve, as shown in Fig. 4-3.



**Fig. 4-3—Queueing Diagram for Uninterrupted Flow**

From Fig. 4-3 it can be seen that:

- a. A queue of vehicles begins to form at time  $t_1$ , and does not disappear until  $t_3$ .
- b. The length of the queue,  $Q(t)$ , at any time  $t$  is approximately  $Q(t) = A(t) - D(t)$ .
- c. A vehicle arriving at  $t$  does not depart until  $W(t)$  later, assuming first-in-first-out (FIFO) queue discipline. This will not be the case, however, when a queue forms behind a slow vehicle; in this situation, the last vehicle to join the queue is likely to be the first one able to change lanes and begin an overtaking maneuver.
- d. The queue is longest at  $t_2$  when the arrival rate equals  $q_m$ .
- e. The total queuing delay is represented by the area between the  $A(t)$  and  $D(t)$  functions.

4 **Analysis of Traffic Densities.** While the concept of recurrent congestion upstream of bottlenecks is fairly straightforward, the complicated traffic pattern resulting from the interaction of several bottlenecks cannot be identified solely by ground observation. In these cases, the pattern may be studied by measuring traffic characteristics and plotting the data in the form of a density contour chart as a function of time and location (Fig. 4-4). The data for this chart can be obtained by taking periodic (e.g., every five to ten minutes) photographs from the air and counting vehicles in a known length of roadway to determine the density. Queues behind bottlenecks can be identified on density-contour charts by highlighting all areas with densities in excess of 30 veh./lane-km. In Fig. 4-4 the queue formed at about 7:10, reached its maximum length at about 7:45, and disappeared at about 8:00. These times correspond respectively to  $t_1$ ,  $t_2$ , and  $t_3$  shown in Fig. 4-3. Note that the high densities occur upstream of, rather than in, the bottleneck.

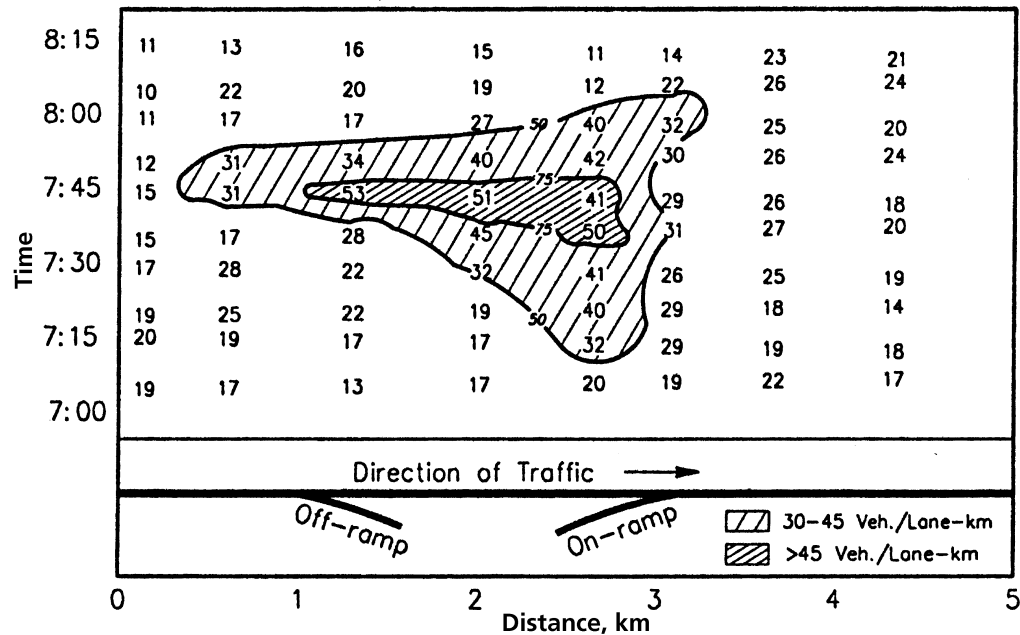

Fig. 4-4—Density Contour Chart

The triangular shape of the congestion zone is typical of a single, isolated bottleneck. The total travel time of all vehicles on the road can be calculated by measuring the area within the contours and then determining the volume within the diagram just as though it were a contour map.

Where vehicle detectors have been installed at frequent intervals along a freeway for traffic monitoring purposes, flow rates and speeds can be obtained continuously, and densities can be calculated and displayed in real time.

- 5 **Application of Density Analyses.** Density and speed charts are particularly useful engineering management tools for monitoring freeway system operation. They clearly indicate the location of bottlenecks and the congestion they create, but they do not permit the direct determination of the effects of bottleneck removal. In the typical case, the elimination of a bottleneck at one location means that throughput will be limited by the capacity at some other, downstream location. Before a congestion project is implemented, therefore, the net amount of improvement to the entire facility or network must be evaluated.
- 6 **Nonrecurrent Congestion.** As noted earlier, this form of congestion results from an unexpected event, such as an accident. The principal difference versus recurrent congestion is one of predictability; for this reason, drivers are more tolerant of recurrent congestion, because they can incorporate it in their trip planning. Figs. 4-3 and 4-4 can be used to describe the nature of nonrecurrent congestion; however, they are seldom illustrated because the description of a past one-of-a-kind incident is of interest only if a repetition is expected.
- 7 **Platooning.** As mentioned in B.6. above, platoons in uninterrupted traffic result from the presence of one or more slow-moving vehicles in the traffic stream, causing faster vehicles approaching from the rear to decelerate to the speed of the slowest vehicle. When the slow vehicle accelerates to normal speed (e.g., at the crest of a hill) or exits the highway, the platoon will disperse, and the "free-flow" condition will return.
- 8 **Shock Waves.** The boundary conditions in a time-space diagram that identify a sudden discontinuity between noncongested and congested flow is referred to as a shock wave. Ref. 4 discusses this theory in detail. Recent research (Ref. 5) has confirmed that shock wave theory provides a coarse approximation of traffic operating conditions.

## D. Interrupted Traffic

- 1 **Traffic Signal Controlled Intersections.** The flow of traffic on the approach to and through an intersection controlled by a traffic signal may be analyzed by:

- a. A time-space diagram, commonly drawn with time on the horizontal axis and distance from a reference point on the vertical axis. The trajectories of individual vehicles in motion are portrayed in this diagram by sloping lines, while stationary vehicles are represented by horizontal lines. In Fig. 4-5, vehicles arriving during the red signal interval are shown queueing on the intersection approach and leaving during the green interval. The curved portions of the trajectories represent vehicles undergoing speed changes—deceleration and acceleration.
- b. The application of fundamental queueing theory, by analyzing the cumulative passage of vehicles as a function of time. Fig. 4-6, which portrays the flow on one intersection approach, shows traffic stopped from  $t_1$  to  $t_2$  during the red signal interval. At the start of the green interval ( $t_2$ ), traffic begins to flow at a rate of  $q_G$ , which continues until the queue is exhausted. Thereafter the departure rate,  $D(t)$ , equals the arrival rate,  $A(t)$ , until  $t_3$ , the beginning of the next red signal interval; at this point, the process starts over.

The slope  $q_G$  is the maximum rate of vehicles entering the intersection. As shown in Fig. 4-5, this headway is usually 2 s/veh/lane. Numerous studies have shown, however, that there is a "loss" of about 3 s at the beginning of each green interval. Because of defensive driving and/or inattentive drivers, the first vehicle in the queue at the signal enters the intersection about four seconds after the beginning of the green, while the next vehicle in the same lane enters about three seconds later. At a signalized intersection with high traffic demand, this loss may be offset by those vehicles entering the intersection during the clearance interval. The 2-second headway corresponds to a flow rate of 1800 veh/h/lane; however, higher flow rates have often been observed at locations where the traffic includes high percentages of commuter vehicles.

- 2 **Platooning.** Initiation of a green indication at a traffic signal generates a platoon of vehicles leaving the intersection. Where signalized intersections are spaced less than 0.4 km apart and

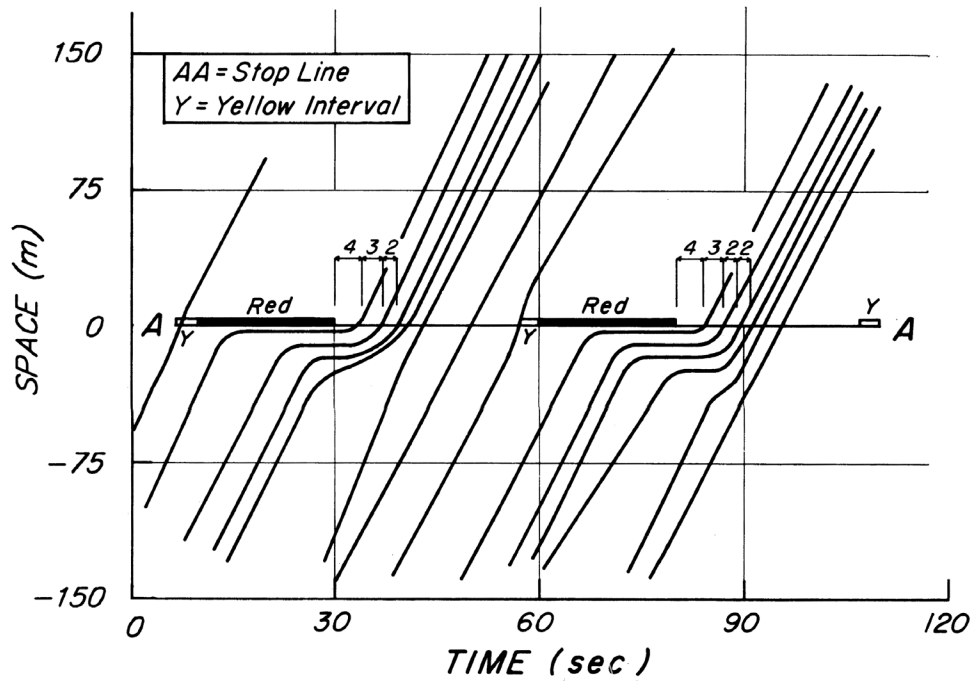

Fig. 4-5—Time-space Trajectories at a Traffic Signal

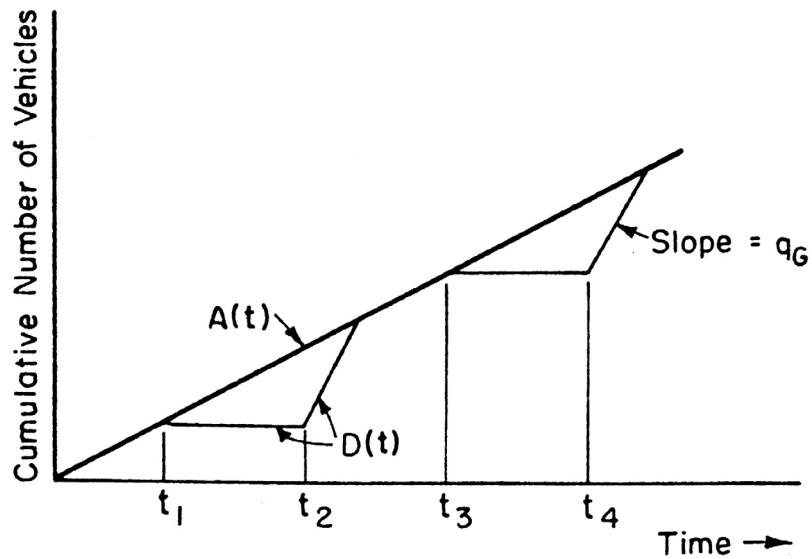

Fig. 4-6—Queueing Diagram for Interrupted Flow

are well coordinated, platoons will move as a group with substantial gaps between them; vehicles on cross street approaches at intermediate unsignalized intersections are then allowed the opportunity to enter or cross the arterial street. In the absence of other nearby signals, platoons will tend to disperse within 0.4 km downstream. With signal separations of 0.8 km, platoons will definitely disperse, especially in those cases where motorists fail to perceive (or believe) that the traffic signals are coordinated.

- 3 **STOP and YIELD Controlled Intersections.** Vehicles on side streets are required to yield the right-of-way to traffic on major intersecting streets. The crossroad drivers must await adequate gaps in the major road traffic stream to cross or merge. A gap is the separation

between the corresponding points on two successive vehicles minus the separation occupied by a vehicle; gaps may be described in distance or time. In terms of time:

$$g_{ij} = h_{ij} - \frac{L_i}{u_i} \quad [4.2]$$

where  $g_{ij}$  = gap between vehicles  $i$  and  $j$ , in  $s$ .  
 $h_{ij}$  = headway between vehicles  $i$  and  $j$ , in  $s$ .  
 $L_i$  = length of vehicle  $i$  (the lead vehicle), in  $m$ .  
 $u_i$  = speed of vehicle  $i$ , in  $m/s$ .

A *lag* is the time interval between the arrival of a vehicle wishing to cross an uninterrupted stream of vehicles on an intersecting path and the arrival of the next vehicle in that stream. Drivers arriving at a STOP or YIELD sign (or preparing to make a left turn across a stream of traffic approaching from the opposite direction) encounter a lag, and must decide whether to accept it (make the crossing or turning maneuver) or to reject it. If the lag is rejected, the driver of a stopped vehicle then faces gaps in the intersecting traffic flow, each of which must now be judged for its acceptability. Fig. 4-7 shows a typical distribution of gaps and lags accepted by drivers facing STOP and YIELD signs.

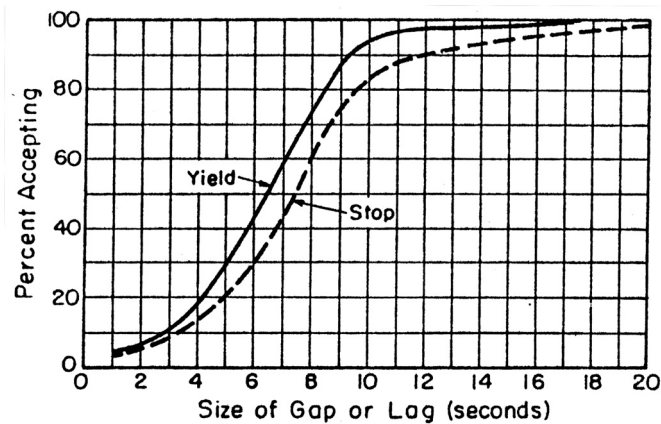

Source: Ref. 6.

**Fig. 4-7—Gap and Lag Acceptance Curves**

The distribution of available gap lengths in a traffic stream is a function of traffic volume and the degree of platooning; the latter depends in part on traffic signal coordination.

- If there is a high proportion of platoons, and the incidence of right-turn-on-red is limited, then one long gap per major street signal cycle will occur for each direction of major street traffic. The length of the gap will determine the number of cross street vehicles that can enter the intersection per cycle. The headways for minor street traffic entering a major street from a STOP sign is typically 4 seconds; in comparison with vehicles entering at a traffic signal, this is about the same as for a lead vehicle or about twice the steady state value.
- In the absence of platooning, available gaps and acceptable gaps are compared, and the highest flow rates for the cross street approaches may be estimated by queueing theory formulae, such as Eq. 4-3. Selected results from solving this equation are shown in Table 4-3.



$$q_{max} = \left[ \frac{e^{-\frac{Q(T-t)}{3600}}}{\frac{Qt}{e^{3600} - 1}} \right] \bullet Q \bullet \left( 1 - \frac{Q^2}{10^7} \right) \tag{4.3}$$

- where  $q_{max}$  = maximum hourly flow rate (capacity) of the controlled approach (veh/h)  
 $Q$  = total flow rate on the uncontrolled street in both directions (veh/h)  
 $T$  = average gap acceptable to the first driver on side street (s)  
 $t$  = average follow-up gap for other drivers to follow first driver into the intersection when a large gap occurs (s).

The term in square brackets (from probability theory) assumes that all drivers are willing to accept the same minimum gap of  $T$  or  $t$ . The term in parentheses, which Ref. 6 applies only to values of  $Q \geq 2000$ , corrects this to allow for the fact that acceptable gaps vary among drivers.

The values for  $T$  and  $t$  shown in Table 4-3 are typically found in field studies (Refs. 6, 7). Values vary with such factors as:

- Whether vehicles start from a full stop (at a STOP sign) or can coast (at a YIELD sign).
- The width of the street to be crossed.
- The mix of vehicle types; trucks and buses require larger gaps or lags.
- The length of vehicles on the controlled approach (affects the move-up time in the queue).
- The acceleration rate of the vehicles.
- The proportion of right turns from the controlled approach (Ref. 8).
- Predominance of elderly drivers (see Chap. 3, Part E.2. and Ref. 9)

**Table 4-3—Maximum Flow Rates Crossing Streams of Uninterrupted Traffic** (using Equation 4.3)

Assumed Value of		Value of Q (veh/h)			Typical Situation
$T$ (s)	$t$ (s)	800	1200	1600	
8	4.5	200	90	40	} STOP sign control
7	4	270	135	65	
6	3.5	365	200	105	
7	3	325	160	70	} YIELD sign control
6	3	*	220	110	
5	3	*	305	175	

\* -This situation is unlikely to occur at YIELD sign controlled approaches.

- c. Analysis of traffic gaps is also useful in evaluating the ability of pedestrians and bicyclists to cross an uninterrupted traffic stream. In this case, safety is of greater importance than capacity. If acceptable gaps, which are considerably longer for pedestrians and bicyclists than for motor vehicles, do not occur with sufficient frequency, delays will become aggravating and these road users may be tempted to take undesirable risks. However, groups of pedestrians can cross in each acceptable gap.

For recent research results on gaps, see Ref. 10.

## E. Further Reading

In addition to the previously mentioned Refs. 1 and 2, Refs. 11 and 12 offer good, basic descriptions of queueing theory. A comprehensive treatment of delay at signalized intersections is given in Ref. 13.

### REFERENCES

1. Gerlough, D.L. and M.J. Huber. *Traffic Flow Theory*. Washington, DC: Transportation Research Board, Special Report 165, 1975, 222 p.
2. May, Adolf D. *Traffic Flow Fundamentals*. Englewood Cliffs, NJ: Prentice-Hall, 1990. 464 p.
3. *Highway Capacity Manual*. Transportation Research Board, National Research Council. Washington, DC: 2000.
4. Lighthill, M.J. and G.B. Whitham. "On Kinematic Waves II: Theory of Traffic Flow on Long Crowded Roads." *Proceedings of the Royal Society*. v. A229, 1955, pp. 317-345.
5. Cassidy, M.J. and J.R. Wendover. "Methodology for Assessing Dynamics of Freeway Traffic Flow." *Transportation Research Record* 1484. 1995, pp. 73-79.
6. DeLeuw, Cather & Co. *Effect of Control Devices on Traffic Operations - Interim Report*. Washington, DC: Highway Research Board, NCHRP Report 11, 1964. 108 p.
7. Daganzo, Carlos F. "Estimation of Gap Acceptance Parameters within and across the Population from Direct Roadside Observation." *Transportation Research*. Rv. 15B, n. 1, Feb. 1981, pp. 1-16.
8. Harwood, D.W., et al. *Intersection Sight Distance*. Washington, DC: Transportation Research Board, NCHRP Report 383, 1996, p. 46-51.
9. Federal Highway Administration. *Older Driver Highway Design Handbook: Recommendations and Guidelines*. Washington, DC: 1998. FHWA-RD-99-045.
10. Tian, Z.Z., et al. "A Further Investigation on Critical Gap and Follow-Up Time." *Proceedings, Fourth International Symposium on Highway Capacity*. Washington, DC: Transportation Research Board, Transportation Research Circular E-C018, p. 397-408. June 2000.
11. Newell, Gordon F. *Applications of Queueing Theory*. 2nd Edition. London: Chapman and Hall Ltd., 1982. 303 p.
12. Blunden, W.R. *The Land Use/Transport System*. Sydney, Australia: Pergamon Press, 1971.
13. Newell, Gordon F. *Theory of Highway Traffic Signals*. Berkeley, CA: University of California, Institute of Transportation Studies. Course Notes UCB-ITS-CN-89-1, 1989. 441 p.



### A. Purpose

Traffic volume is the most basic and widely used parameter in traffic engineering. However, different agencies have employed varying definitions and methods in the collection, analysis, and description of traffic volume data. As a result, AASHTO (Ref. 1) and ASTM (Ref. 2), driven by the requirements of long-term pavement performance monitoring systems, have standardized traffic volume terminology and procedures to ensure that the traffic engineering community utilizes common traffic monitoring practices to provide high-quality data for decision making.

Specific volume studies are undertaken to obtain factual information on the movement of vehicles and/or persons at selected points on the highway system. The resulting volume data are expressed in relation to time, with the base determined by the application in which the information will be used.

- 1 **Annual Traffic** in vehicles or vehicle•kilometers (veh•km) per year is used for:
  - a. Determining travel and volume trends in a geographic area.
  - b. Estimating expected highway user revenue.
  - c. Computing accident rates.
  - d. Monitoring long-term pavement performance (LTPP).
- 2 **Annual Average Daily Traffic (AADT) or Annual Average Weekday Traffic (AAWDT - see Ref. 2)** in vehicles per day is used for:
  - a. Measuring or evaluating the present demand for service by the street or highway.
  - b. Developing the major or arterial street system.
  - c. Locating areas where new facilities or improvements to existing facilities are needed.
  - d. Programming capital improvements.
- 3 **Hourly Traffic** in vehicles per hour is used for:
  - a. Determining length and magnitude of peak periods.
  - b. Evaluating capacity deficiencies.
  - c. Assessing the need for traffic control device installation.
  - d. Geometric design or redesign of streets and intersections.
- 4 **Short Term Counts** (totaled at 5- to 15-minute intervals) are usually expanded into hourly flow rates. Such counts are primarily used to analyze:
  - a. Maximum flow rates.
  - b. Flow variations within peak hours - the Peak Hour Factor (see G.3.c. below).
  - c. Capacity limitations on traffic flow.
  - d. Characteristics of peak volumes.

- 5 **Density of Traffic** in vehicles per kilometer is obtained by dividing the hourly volume by the average speed. Density may be a better measure of street service than volume since it continues to increase as congestion increases. Volume, on the other hand, reaches a maximum under moderate congestion and then decreases with greater congestion. When a complete blockage occurs, density is at its maximum, and volume is zero. (The generalized relationship between volume, speed, and density is shown in Fig. 4-1.)

## B. Volume Studies

The type of data collected in a specific volume study depends upon the application in which the information will be used.

- 1 **Street Counts** (total volume without regard to direction) are used in developing daily volumes, preparing traffic flow maps, and determining trends.
- 2 **Directional Counts** are used for capacity analysis, determining signal timing, justifying traffic controls, monitoring loads on pavements, and obtaining accumulations of vehicles within a cordon.
- 3 **Turning Movement or Intersection Counts** tally movements at an intersection and are used for timing traffic signals, designing channelization, planning turn prohibitions, computing capacity, analyzing high accident intersections, and evaluating congestion.
- 4 **Classification Counts** obtain volumes by class of vehicles, including bicycles, in the traffic stream and are used in establishing structural and geometric design criteria, computing expected highway user revenue, computing capacity (effect of commercial vehicles), and determining correction factors for machine counts.
- 5 **Occupancy Counts** are made to determine the distribution of passengers per vehicle, accumulation of persons within an area, and proportion of persons utilizing different travel modes.
- 6 **Pedestrian Counts** are used in evaluating sidewalk and crosswalk needs, justifying pedestrian signals, and timing traffic signals. (See Chap. 20.)
- 7 **Cordon Counts** are made at the perimeter of an enclosed area (e.g., CBD, shopping center, industrial area). Vehicles and/or persons entering and leaving the area during a specified time period are counted. These data provide information relative to the accumulation of vehicles or persons within the cordon. (See Chap. 11, Sec. D.8.)
- 8 **Screen Line Counts** are classified counts taken at all streets crossing an imaginary line (screen line) bisecting an area. These counts are used to determine trends, expand urban travel data, and verify traffic assignment. (See Chap. 11, Sec. D.8.)

## C. Counting Techniques

The collection of traffic volume data requires the detection of vehicles (or vehicle types, pedestrians, or vehicle occupants) and the recording of this information. Refs. 3 and 4 describe the equipment commonly used for these purposes.

- 1 **Traffic Detection** may be accomplished in the following ways:
  - a. *Observers* are stationed in the field to count the passing traffic. This is the most efficient method for short-duration (e.g., peak period) counts where the time and effort to place mechanical detection cannot be justified. Human observers are the only practical method for monitoring vehicle occupancy and the most realistic method for monitoring bicycle and pedestrian traffic. Prior to recent improvements in detection technology, observers were the only dependable method for conducting intersection turning movement and vehicle classification studies; they remain the best choice for brief studies of these types.
  - b. *Hollow pneumatic road tubes*, stretched across the roadway, have been the traditional form of vehicle detection for portable counters. An air pulse, generated when a tire rolls over the

rubber tube, is transmitted to a diaphragm switch in a counter and converted into an electric impulse. Since the road tube detects axles rather than vehicles, counters are designed to interpret two impulses as a single vehicle. A correction factor must be applied at locations with significant numbers of vehicles with 3 or more axles. Pneumatic tubes are troublesome to place on high volume facilities, are unsuitable for high speed roadways, and are subject to wear and vandalism.

- c. *Tapeswitches* (a pair of thin metal strips separated by a high-resistance material) and piezoelectric cables have also been used to detect passing vehicles. When deployed with portable counters, they have advantages and disadvantages similar to pneumatic tubes. New types of piezoelectric cables can be placed in the pavement at permanent count locations.
- d. *Loops* (one or more turns of wire in a saw-cut slot) imbedded in the pavement are the most common detector at permanent count locations. These devices detect an inductance change due to a passing vehicle and send this information to an electronic amplifier (see Chap. 15, Sec. D.9.). This device counts vehicles rather than axles. A loop can be placed in each lane. Loops may break, especially when placed in asphaltic concrete (Ref. 5). Some agencies have successfully employed temporary loops taped to the roadway surface.
- e. *Microwave sensors* (typically mounted at the side of the road about 6 m above the surface) distribute a low-power radar signal of varying frequency in a fan-shaped beam; reflections from passing vehicles are returned to the sensor, and if they are within a predefined detection zone, are counted. Sonic sensors, typically mounted over a traffic lane, "hear" sounds from passing vehicles and, with the use of software, distinguish passenger vehicles from trucks. Both devices provide alternatives to inductance loops at permanent count locations.
- f. *Vehicle magnetic imaging* (VMI) employs a very low-powered device to detect distortions in the earth's magnetic field caused by a vehicle passing over the sensor. This technology, that can also be used to collect vehicle classification data, provides a viable alternative to pneumatic tubes for short-term counts. A current design utilizing this technique incorporates a detector and a recorder in a single unit.
- g. *Video cameras*, when combined with video image processing technology, offer an alternative method of vehicle detection. Video systems permit the creation of virtual loops, that can be used to detect turning vehicles at intersections. These systems are most appropriate for permanent count locations.

2 **Volume Data Recording** may be accomplished using a variety of equipment types.

- a. Manual tally counters mounted on boards are still sometimes used to collect intersection turning counts; the observer is required to transfer data from the counters to a recording sheet at a specified time interval (e.g., every 15 minutes). The modern-day equivalent of this device is a 16-button electronic count board: one button tallies each left-turn, through, right-turn, and "other" for every approach to the intersection. The count board sends data to an internal computer memory, thus avoiding transcription errors in the field. Data from these devices can be played back in the office or downloaded directly onto a personal computer.
- b. An older type of portable mechanical traffic volume counter accepted input from a pneumatic road tube and incremented an internal counter that was periodically read by the observer. More advanced models included a clock and printing devices that recorded count data on paper or magnetic tape at specified time intervals. Because of their large power requirements, the units were bulky and heavy.

Today, manufacturers offer a wide variety of traffic volume recording devices, virtually all of which save the count information in computer memory. Some recorders can be programmed to start and stop data collection at specific times, to record information at specified time intervals, and to simultaneously collect other information such as vehicle classification, speed, and headway. Most portable recorders are mounted securely at the roadside, although one unit (the size of a credit card and about 5 mm thick) utilizing VMI detection is actually placed in the road. Virtually all of the counters weigh less than 5 kg, and because of their low power requirements, battery life is measured in months or even years.

- c. In addition to computerized data, systems utilizing video camera detection can retain video files of the data. This permits the subsequent analysis of other traffic parameters, such as pedestrian volumes or traffic conflicts.
- d. Recording counters employed at permanent count locations have benefitted from the technological changes that have improved portable counters. In addition, recording devices at these locations are checked daily with polling software that downloads volume data to a central location, verifies clock accuracy, and checks for possible equipment problems (e.g., multiple successive hours with identical volumes). Polling is generally accomplished using hard-wired or cellular phone lines.

## D. Counting Periods

The time and duration of traffic counting at a particular location depends on the data desired, the anticipated application of this information, and the expected variation in traffic volumes from one period to the next.

- 1 To help ensure that traffic monitoring procedures yield adequate traffic data and summary statistics, ASTM (Ref. 2) recommends the following minimum durations for short-term traffic volume and vehicle classification counts using mechanical equipment:
  - a. 48 consecutive hours for non-Interstate rural roads and 24 consecutive hours for non-Interstate urban roads.
  - b. 48 consecutive hours on urban and rural Interstate roads and interchange ramps.

Counts taken on Monday through Thursday are referred to as weekday counts, while those taken on Saturday and Sunday are weekend counts. Depending on the conditions at the particular site, Friday traffic volumes could be representative of the typical weekday or the weekend. According to Ref. 2, Friday volumes may be included with weekday or weekend counts, as long as their inclusion does not increase the coefficient of variation.
- 2 Other commonly used counting periods include the following:
  - a. 16 h counts, typically between the hours of 6 am and 10 pm. While conditions vary among sites, this period normally accounts for 90-95% of the daily traffic volume.
  - b. 12 h counts, usually between the hours of 7 am and 7 pm. This limited period will miss the early morning business (especially freight delivery) and commuter traffic, as well as evening traffic, much of it shopping and leisure trips.
  - c. Peak period counts, traditionally conducted between 7-9 am and 4-6 pm. However, the occurrence of actual peak periods varies throughout a metropolitan area in response to the proximity of major traffic generators. Because of the growth of congestion on major transportation facilities and the use of staggered or flexible work hours, peak periods in larger urban areas can extend far beyond two hours in the morning and afternoon.
- 3 Special conditions should be avoided unless the purpose of the count is to obtain data concerning these unusual conditions, such as:
  - a. Special events (e.g., holidays, sports, exhibitions, the Friday after Thanksgiving).
  - b. Temporary street closure affecting the volume pattern.
  - c. Transit or trucking strikes.
  - d. Time period preceding and following a disaster.
- 4 Adjustment factors must be applied to the data to remove seasonal or other variations, to provide a realistic estimate of the average volume condition, and/or to expand a count to a volume estimate of a longer period. These factors may be obtained by means of permanent count stations or through an established counting program (see E. below). Short term counts for special studies are used without modification.

## E. Counting Programs

Regularly scheduled volume counts are essential for obtaining and maintaining accurate, current traffic volume data for street and highway systems. These data are of critical importance in highway planning and design.

- 1 **Rural Counting Programs** vary considerably from one agency to another, depending on the nature of the roadways and the area covered. Generally, highways are grouped according to their traffic characteristics into categories such as farm routes, general purpose routes, recreational routes, and winter resort routes. Control stations are established on each type of highway to provide data on seasonal variation. Counts are taken at these locations monthly or bimonthly. FHWA's Highway Performance Monitoring System (Refs. 6 and 7) describes procedures for conducting short-term coverage counts for use in estimating traffic on the rural road system.
- 2 **Urban Counting Programs** differ from those in rural areas due to the different traffic patterns that exist in urban areas. Because the numerous needs for urban traffic volume counts must be balanced against financial constraints, urban traffic agencies must develop a comprehensive but realistic plan for the collection of traffic volume. One plan is outlined below:
  - a. *Designation of street system* is the first step in developing the count program.
    - (1) Major streets include freeways, expressways, arterials, and collector streets.
    - (2) Minor or local streets are designated as residential, commercial, or industrial.
  - b. *Control counts* provide the controls necessary to record volume counts on a common basis.
    - (1) Major control stations are selected to sample the traffic movement on the major street system. One station should be located on each major street. The minimum recommended duration and frequency of counting is a 24-hour directional machine count every second year.
    - (2) Minor control stations should be located so as to sample typical streets of each classification in the minor street system. A minimum of three stations of each class described above should be established in a small city. A 24-hour nondirectional machine count should be performed biennially.
    - (3) Key count stations are selected control stations used to obtain daily and seasonal variations in volumes. At least one key station should be selected from each class of street in both the major and minor system. These stations are counted as follows:
      - (a) A nondirectional, seven-day count performed annually.
      - (b) A nondirectional, 24-hour, weekday count monthly or quarterly.
  - c. *Coverage counts* are used to estimate ADT volumes throughout the street system.
    - (1) On the major street systems, one nondirectional, 24-hour weekday count should be taken within each control section. Since only the 24-hour total is needed, nonrecording counters are satisfactory. The counts should be repeated every four years.
    - (2) On the minor streets, one 24-hour, nondirectional, nonrecording count should be made for every mile of minor street. Counts are repeated when local circumstances indicate a need.
  - d. *CBD cordon counts* are used to measure the transportation activity generated by the Central Business District. Procedures and a sampling technique are described in detail in Ref. 3. These counts should be repeated every other year.
  - e. *Screen line counts* are intended to detect long-range changes in volume and direction of traffic due to significant changes in land use and travel patterns. Details of such counts are presented in Ref. 3. Screen line counts should be made every second year.
- 3 **Statewide Counting Programs.** As an example, the California Department of Transportation (Caltrans) provides AADTs at about 7,000 profile points on the 24,300 km of the state highway system. The count program is on a basic 3-year cycle with one-third or more of each district's traffic counts being made each year. On routes where there is little



change in traffic or in the seasonal factors, counts are taken less frequently, but at least once every six years. For that section of a route where AADT is undergoing rapid change, counts are made more frequently.

a. *Types of counts.*

- (1) *Control station counts* obtain AADTs and seasonal factors that are used to expand sample counts. They are recorded hourly by direction, and there are three types:
  - (a) *Trend counts* are obtained continuously at 22 designated locations to reflect the statewide change in travel, to calculate the annual VKT (veh•km traveled), and for reports required by the FHWA (e.g., for compiling performance data shown in Chap. 2).
  - (b) *Monthly counts* are similar to trend counts in all but name; they are collected continuously at more than 400 additional sites for interpretation and expansion of quarterly and sample counts.
  - (c) *Quarterly counts* are obtained for the same week-long period once each quarter. They are taken along a highway at points of low, high, or rapidly-changing traffic volume, at or near the end of highway routes, and at the beginning or ending points used for freeway ramp balancing.
- (2) *Sample counts* are obtained for short periods of time, generally one day, at points of significant change in traffic volume, on freeway ramps and connectors, and at other necessary locations. Sample counts require factoring to AADT.
- (3) *Vehicle classification counts* are continuously collected in 15 categories using Automatic Vehicle Classification (AVC) and Weigh-in-Motion (WIM) devices permanently installed at 85 locations on the state highway system. One- to seven-day vehicle classification counts are performed using portable AVC devices; these are primarily deployed on rural two-lane conventional highways. Data from the continuous AVCs and WIMs are used to factor the short-term counts into Annual Average Daily figures.

b. *Reports.* The following reports, among others, are produced (summarized from Ref. 8):

- (1) Annual Report of Traffic Volume on California State Highways. This report (Ref. 8a) lists traffic volumes for all count locations on the California state highway system. Peak hours, peak month ADTs, and AADTs are shown at each count location.
- (2) Annual report of truck volumes on California state highways (Ref. 8b).
- (3) Annual reports of ramp volumes on California freeways (Ref. 8c).
- (4) Peak hour (am and pm) volumes as percentages of the AADT (Ref. 8d). This includes an estimate of the "peak hour" traffic at all points on the state highway system. In urban and suburban areas, the peak hour normally occurs every weekday, and 200 or more hours per annum will all be about the same. On roads with large seasonal fluctuations in traffic, the peak hour is near the maximum for the year but excluding 30 to 50 hours that are exceedingly high and are not typical of more frequently occurring high hours.

## F. Presentation of Volume Data

When volume data are shared with the public in reports, the method of presentation must clearly illustrate the features being analyzed. The engineer should utilize appropriate computer tools to create:

- 1 **Trend Charts**, showing the volume change over a period of years.
- 2 **Variation Charts**, showing seasonal, daily, or hourly volume changes (Figs. 5-1 and 5-2).
- 3 **Intersection Flow Diagrams**, showing turning movements, especially for the peak hour (Fig. 5-3).
- 4 **Traffic Flow Maps**, showing volumes (by widths or color-coded) on a street system (Fig. 5-4).
- 5 **Summary Tabulations** showing results of extensive counting programs (Ref. 8).

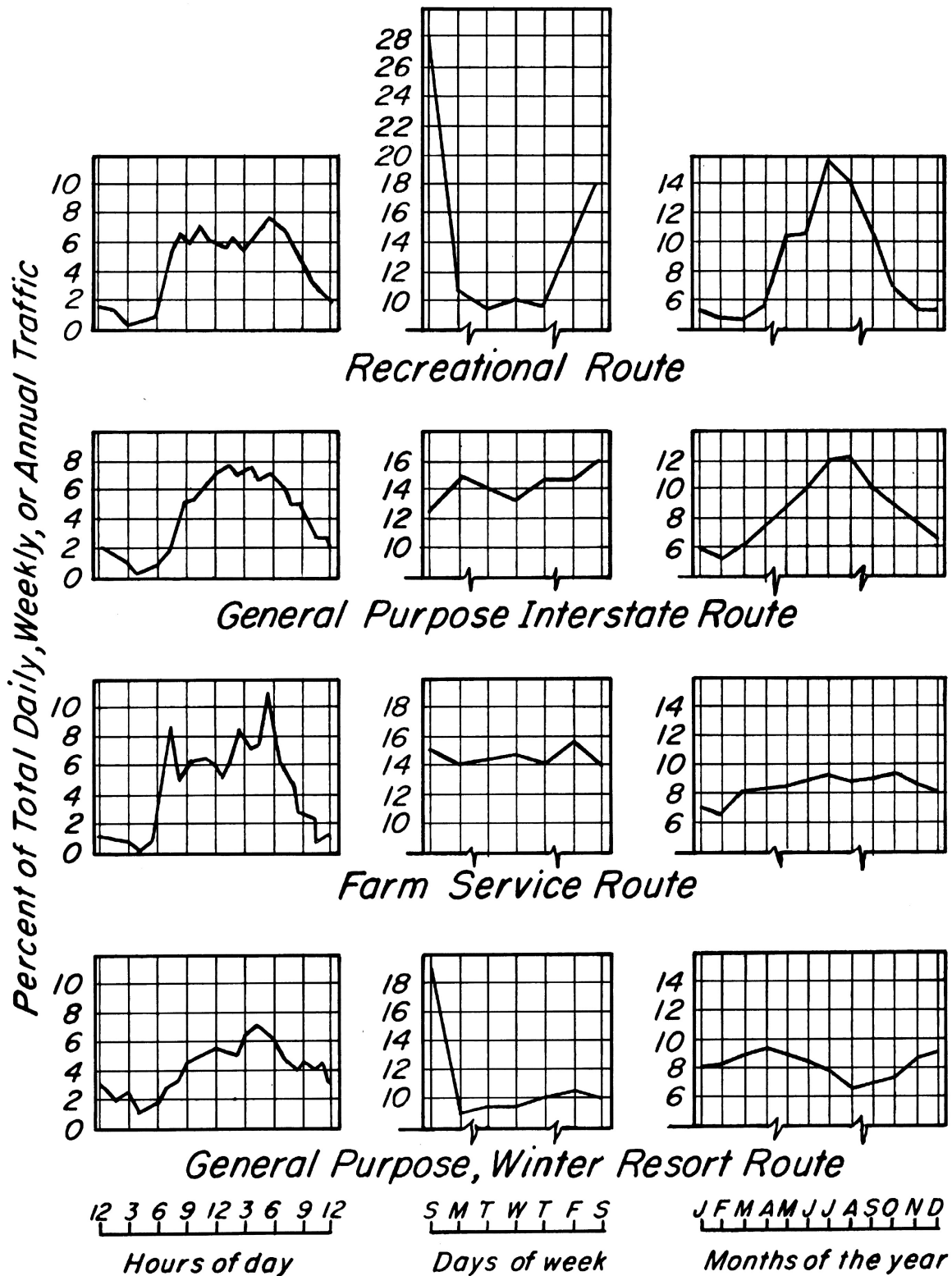

Fig. 5-1—Volume Variations on Rural California Highways

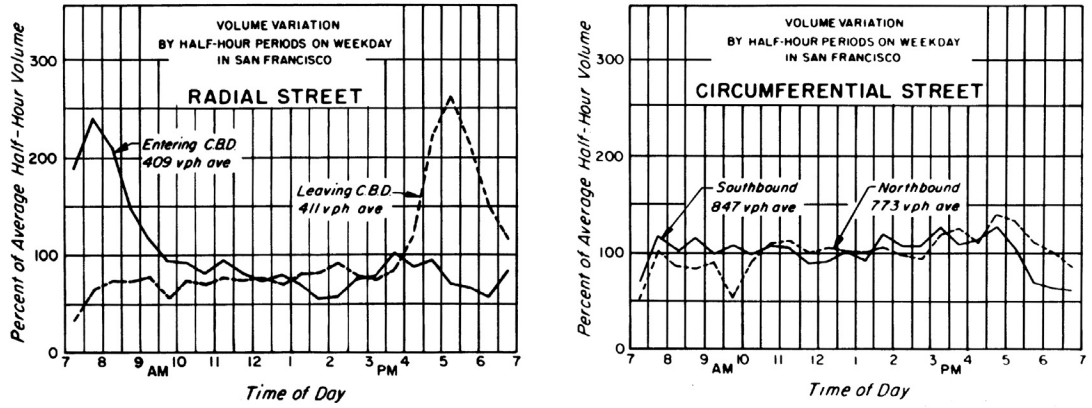

Fig. 5-2—Comparison of Flow on Radial and Circumferential Streets

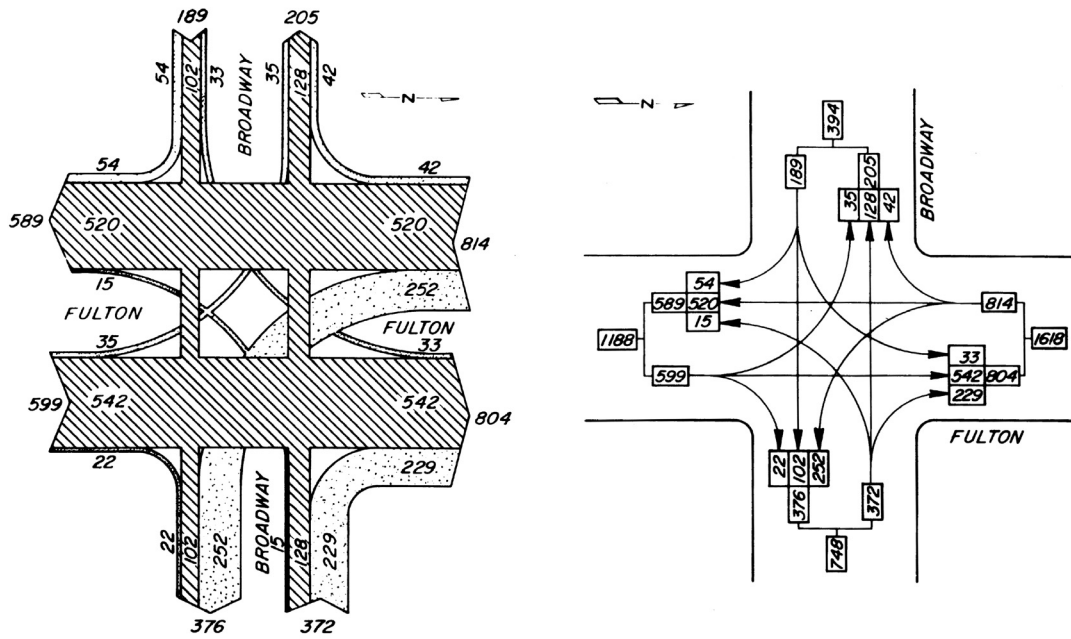

Fig. 5-3—Examples of Intersection Flow Charts

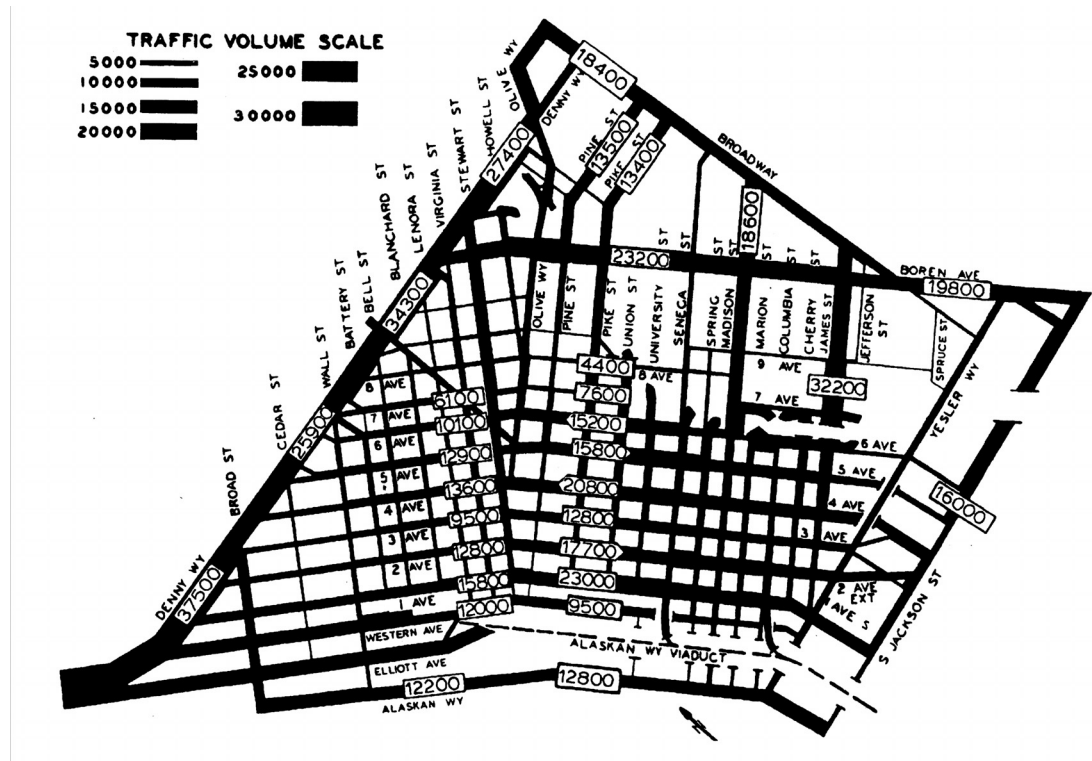

Fig. 5-4—Average Daily Traffic Volumes

Source: Office of the City Traffic Engineer, Seattle, WA.

G. Volume Characteristics

Traffic volumes exhibit general characteristics depending on conditions at the site (Ref. 9).

1 **Variables** that affect volume characteristics include:

- a. Type or classification of street or highway.
  - (1) Rural - Interstate, state, or county.
  - (2) Urban - freeway, arterial, collector, or local.
- b. Usage—intercity or Interstate, farm service, recreational, commercial, land service, commuter, or general purpose.
- c. Composition of traffic—proportions of autos, trucks, or buses.
- d. Temporal variation.

2 **Rural Characteristics** are shown for various types of roads in California in Fig. 5-1:

- a. A *recreational route* with high summer traffic and a high Sunday peak.
- b. A *general purpose interstate route* having no Sunday peak. However, high summer volumes exist, due to the heavier long-distance leisure travel.
- c. A *farm service route* with little variation between days of the week or months of the year.
- d. A *general purpose, winter resort route* with high Sunday peak and higher winter and spring volume.

3 **Urban Volume Characteristics** differ from those in rural areas, since volumes are higher and more concentrated during certain hours of the day.

- a. Peak-hour volumes are usually quite pronounced and directional in nature on radial streets used by commuters. Circumferential streets, on the other hand, do not have such sharp peaking characteristics. A comparison between radial and circumferential streets in San Francisco is shown in Fig. 5-2.
  - b. Durations of peak flows vary and are important in planning controls that affect traffic flow (such as signal timing). A sustained peak volume is more critical than a sharp peak of short duration.
  - c. Within an hourly volume, arrival rates can vary considerably. The peak hour factor (PHF), the ratio of the hourly volume to the peak flow rate, can be used to describe this variation.
    - (1) The highest 15-minute period may reach 40% of the hourly volume, corresponding to a PHF of 0.625.
    - (2) The highest 5-minute period may be 20% of the hourly volume (PHF = 0.42).
    - (3) Short-term arrival rates are important when studying frequencies of gaps in traffic of sufficient length to permit pedestrians and vehicles to enter and cross the stream.
- 4 **Design Hourly Volumes** (DHV) are used for the geometric design of new facilities. A common policy is to design for the 30th highest hourly volume (out of the 8760 hours in a year) expected to occur in some future year. To obtain this figure, knowledge of the current 30th highest hourly volume at similar facilities in similar locations is useful. If permanent counters are available for comparable situations, the 30th highest hours can be taken off the records, and the DHV calculated by appropriate estimates of future traffic growth. When permanent counts are not available, the figure must be obtained by estimating the relationship of the 30th highest hourly traffic volume of the year to the AADT. In rural areas the 30th highest hour is from 12 to 16% of AADT while in urban areas the range is 9 to 13%. This process should be used cautiously on rural recreational routes where there may be substantial volume variations among the highest hours of the year.

#### REFERENCES

1. American Association of State Highway and Transportation Officials. *AASHTO Guidelines for Traffic Data Programs*. Washington, DC: 1992. 114 pp.
2. American Society for Testing and Materials. *Standard Practice for Highway-Traffic Monitoring*. (ASTM) Standard E 1442-92a. Annual Book of ASTM Standards, Vol 04.03. 1994.
3. Robertson, H.D., and J.E. Hummer, "Volume Studies," In: *Manual of Transportation Engineering Studies*. Englewood Cliffs, NJ: Prentice-Hall, 1994. Chap. 2.
4. French, A., and D. Solomon. *Traffic Data Collection and Analysis: Methods and Procedures*. NCHRP Synthesis of Highway Practice 130. Transportation Research Board. 1986. 58 pp.
5. Kell, J.H., I.J. Fullerton, and M.K. Mills. *Traffic Detector Handbook—Second Edition*. McLean, VA: U.S. Federal Highway Administration. 1990. 337 p.
6. U.S. Federal Highway Administration. *Highway Performance Monitoring System*. Washington, DC: 1987.
7. U.S. Federal Highway Administration. *Traffic Monitoring Guide*. Washington, DC: 1985.
8. Traffic Operations Division, California Department of Transportation. *Traffic and Vehicle Data*. Sacramento, Annual. Available at <http://www.dot.gov/hq/traffops/saferesr/trafdata/index.htm>.
  - a. Traffic Volumes;
  - b. Truck Traffic;
  - c. Ramp Volumes;
  - d. Peak Hour Volume Data.
9. Kyte, M. and S. Teply. "Traffic and Flow Characteristics," In: *Traffic Engineering Handbook*, 5th Edition. Washington, DC: Institute of Transportation Engineers, 2000. Chap. 4.

### A. Definition

A spot speed study is performed by measuring the individual speeds of a *sample* of the vehicles passing a given point (spot) on a street or highway. The speed characteristics of the sample are used to *estimate* the speed distribution of the entire traffic stream (the population) at that location under the conditions prevailing at the time of the study. Spot speed studies are undertaken for relatively short time periods; speed monitoring over extended periods, for the purpose of roadway surveillance and control, are not spot speed studies.

### B. Purposes

The parameters and distributions obtained from speed studies have many applications in highway and traffic engineering:

- 1 **Speed Trends** can be obtained by periodic sampling at selected locations. The effect of major changes, such as revisions in a speed limit, can be monitored.
- 2 **Traffic Control Planning** may require speed distribution information. Vehicles passing a location travel at various speeds; the amount of dispersion or spread in vehicle speeds affects both capacity and safety. If all vehicles traveled at identical speeds, capacity would be at a maximum, and collisions caused by overtaking would be eliminated. Speed distributions are used to:
  - a. Establish maximum and minimum speed limits (see Chap. 22).
  - b. Determine need for posting safe speeds at curves.
  - c. Properly locate traffic control devices, especially warning signs.
  - d. Determine the yellow interval for traffic signal timing.
  - e. Evaluate intersection sight distances.
  - f. Establish lengths of no passing zones.
- 3 **Before-and-After Studies** are frequently performed to evaluate the effect of changes in roadway design or traffic control. Speed hump installations, for example, are evaluated in this manner.
- 4 **Safety Studies** at problem locations often include analyses of spot speed data.
- 5 **Citizen Complaints** of perceived excessive speed on local streets should be evaluated in part with a speed study.
- 6 **Geometric Design** utilizes speed distributions in determining the adequacy of horizontal curve radius and superelevation, acceleration and deceleration lane lengths, and stopping sight distance availability. The relationship between travel speed and design is also helpful in geometric design of roads and streets.

7 **Research Studies** frequently utilize speed data. Some examples include:

- a. Study of capacity in relation to average speeds.
- b. Analysis of speed-volume relationships.
- c. Influence of roadside obstructions or distractions on speed.

## C. Study Locations

The selection of a site for a spot speed study requires careful consideration.

1 **General Location** depends on the purpose of the study.

- a. Trend stations are usually established on open stretches of tangent freeways and rural highways and at mid-block locations on urban streets away from the influence of STOP signs and signals.
- b. When study results will be used in planning controls, the site must encompass the curve, intersection, school zone, or other condition being evaluated. Locations where vehicles will be accelerating or decelerating during the speed measurement must be avoided.
- c. Before-and-After studies sites must be located to assess the condition that has changed.
- d. Sites for problem location studies should normally be selected to measure approach speeds prior to the point where vehicles are affected by the situation under study.

2 **Specific Site** is selected within the general location to minimize the influence of the data collector and measuring equipment on vehicular speeds. Factors to be considered include:

- a. Equipment and study personnel should be made as inconspicuous as possible to the approaching motorist. Accumulations of on-lookers must be avoided.
- b. Observer should be located so that data can be recorded without being obvious to drivers.
- c. Observer's vehicle should not appear to pose a "threat" to motorists; positions behind guardrail or a fence, on an overpass, beyond the paved shoulder, or in the parking lane are preferred. The observer should not use an official-looking vehicle.
- d. Radar and laser equipment should be positioned to provide an angle of 10° or less with the traffic stream.
- e. To the extent practical, before-and-after studies should employ identical study positions.

3 **Variables That Influence Speeds** must be recognized because their presence may bias the study results. In some cases, however, spot speed studies may be undertaken specifically to determine the effect of these conditions on speed. These variables include:

- a. *Physical Conditions.* Curvature, grade, sight distance, pavement roughness, spacing of intersections, and roadside development.
- b. *Environment.* Roadway classification, area (rural or urban), posted speed limit, type of driver (e.g., local or out-of-state), time of day, weather, and presence of enforcement.
- c. *Traffic Flow.* Volumes, classification, turning movements, and pedestrians.

## D. Time of Study

The time period for speed data collection depends on the purpose of the study. Off-peak hours are normally preferred because they facilitate the collection of free-flowing vehicle speeds. Trend studies and before-and-after studies must be made during the same hours under comparable conditions.

## E. Size and Selection of Sample

In conducting a spot speed study, the traffic engineer seeks to determine the characteristics of a population of vehicles (e.g., all northbound free-flowing vehicles at a particular site) by collecting data for a sample of vehicles passing the site. Large, unbiased samples are needed to achieve this objective. A minimum sample of 100 vehicles is recommended, but larger sample sizes may be needed for special studies (see Sect. G.3.e); Appendix A provides further guidance on sample size determination. The observer must select vehicles in a random but representative manner from the traffic stream. Because mistakes in sample selection cannot be detected or corrected during subsequent analyses, it is essential that data collectors be trained to avoid common errors that introduce sample bias:

- 1 Unless study requirements dictate otherwise (e.g., measurement of speed for congested conditions), the sample should be restricted to free-flowing vehicles, whose drivers have a choice in selecting their desired travel speed. Ref. 1 recommends a 4-s minimum headway to define free flowing, although larger values are preferred if traffic conditions permit.
- 2 The speed of the lead vehicle in a platoon is easily measured, but the vehicle may not be free flowing. Some motorists increase their speed when they perceive they are being trailed too closely by a following vehicle. Other vehicles in the platoon should be avoided; they might select higher speeds if they were not blocked by those ahead of them.
- 3 On the average, trucks operate at lower speeds than the remainder of the traffic stream. Selecting an excessive proportion of trucks introduces sample bias, and produces skewed results. On Interstate freeways, the same principle applies to out-of-state drivers. Both groups should be proportionally represented in the sample.
- 4 Observers have a tendency to select too many higher speed vehicles; indeed, novice observers have been known to stop measurement of a normal speed vehicle in order to catch a high speed vehicle. Like any other subgroup of the traffic stream, the proportion of speeders in the sample should equal their representation in the free flowing traffic stream.
- 5 Field data collectors must be cognizant of real-time events that may temporarily alter speeds. The brief presence of enforcement activity, emergency vehicles, over-wide loads, maintenance activities, vehicles stopped on the shoulder for repairs, pedestrians crossing the roadway, or even hitchhikers, can affect the traffic speeds. Data collection should be discontinued until the situation returns to normal.

## F. Data Collection

The speed of a vehicle passing a point on the roadway can be measured in several ways; the most suitable method depends on the available equipment and the study duration. Because speed is defined as  $\Delta x/\Delta t$ , the most obvious techniques for monitoring speed measure either the time required for a vehicle to traverse a known distance or the distance covered in a known time period.

- 1 **Time vs. Measured Distance.** Vehicles are timed over a measured course or "trap".
  - a. *Manual Timing.* Marks may be placed on the pavement to create a trap. The field observer starts and stops a watch as a vehicle passes these points. Trap length should be established in relation to the expected speeds at the site, with the objective of obtaining typical times of about 4 s. For example, speeds of 50 km/h (13.9 m/s) might utilize a trap 50–60 m in length. Although this technique can produce acceptable results for approximate speeds, errors due to stopwatch delays and parallax limit its applicability.
  - b. *Machine Recorders.* Manual timing problems can be avoided using an electronic (micro-processor-based) timer. These units receive input from a pair of sensors that detect the passage of a vehicle or its front axle; typical sensors include loop detectors, pneumatic tubes, piezoelectric cables, and tape switches (see Chap. 15, Sec. D.9., and Ref. 2).



- (1) Using the precisely measured time and the known distance between sensors, the device calculates and stores vehicle speeds.
  - (2) Detector separations for these units are relatively short, typically 1–3 m. It is especially critical that they be placed accurately on the pavement. For example, the speed of a vehicle traveling 80 km/h through a nominal 1.2 meter trap would be recorded as 79 km/h if the trap was actually 15 mm longer.
  - (3) The temporary placement of detectors on the highway must be carefully planned and implemented to ensure data collector safety; Ref. 3 provides useful guidance in this regard. Loop detectors may be installed permanently at sites where speeds will be collected on a periodic basis.
  - (4) The primary limitation of machine speed recorders is that they detect the speed of every passing vehicle, rather than those that are free flowing. Although this would be an advantage when monitoring the real-time roadway operation in order to detect incidents, the primary purposes of spot speed studies (see Sec. B.) require free-flowing vehicle speeds, where motorists select their speed based on their assessment of roadway and environmental conditions. Unlike human observers, machine recorders are unable to recognize conditions (such as those cited in Sec. E.5.) and to discard speed observations obtained when these factors affect the motorists' choice of speed. Unpublished data from rural, low-volume freeway speed monitoring sites found that machine recorders reported average speeds about 3 km/h lower than the average speeds of free-flowing vehicles; this difference would certainly be greater in urban areas and on roads with higher traffic volumes.
- c. *Video Imaging.* Equipment and associated software are available that permit the engineer to use a personal computer together with the output from a video camera to create and place detection zones, as an alternative to imbedded loops, on a street or highway. This technology can readily measure vehicle speed, but equipment cost and the logistics of placing cameras in the field restrict the application of this technology to intersection control and freeway surveillance.
- 2 **Distance vs. Measured Time.** This procedure, more common in research projects, utilizes video equipment to photograph the traffic stream at fixed time (typically 1/30 or 1/60 s) intervals. The distance a vehicle moves between successive frames is used to calculate the speed. Video-based systems are widely employed for collecting other traffic data (e.g., volume, traffic composition, lane changes); once installed, they can be adapted to speed monitoring. Some systems automatically record and store data in a computerized format to facilitate tabulation. Video technology also provides a permanent record, an attribute rarely needed in a spot speed study.
- 3 **Radar Speed Meters.** Several manufacturers offer radar speed meters that can be used to measure vehicle speeds. The devices are typically a one-piece unit that displays vehicle speed in km/h (or mph) in a digital format.
- a. *Operation.* Radar meters operate on the Doppler principle that a radio wave reflected from a moving target changes its frequency in proportion to the speed of the target. The antenna broadcasts a radio wave along the highway and receives reflected waves from moving vehicles in the vicinity. The device's electronics evaluate the difference between transmitted and received frequencies, convert the result into vehicle speed, and display the result to the operator. The strongest returned signals come from heavy vehicles, such as trucks and busses, and from vehicles closest to the antenna. The accuracy of the unit must be periodically checked with a tuning fork provided by the manufacturer.
  - b. *Technique.* The unit is positioned in the observer's vehicle and aimed at an angle of 10° or less to the traffic flow; if conditions require a larger angle, a correction based on the cosine of the angle should be applied (see Ref. 3). Because radar meters measure the speeds of vehicles moving toward and away from the unit, the observer must ensure that data are recorded only for those vehicles traveling in the proper direction. In many spot speed

studies, it may be preferable to measure speeds of vehicles as they are moving away from the meter. Under light to medium traffic conditions, a single observer can identify a free flowing vehicle, measure its speed, and record the data within 15–20 seconds. Table 6-1 presents the data from a radar spot speed survey on an urban collector street.

- c. *Radar detectors.* Radar speed meter studies can produce distorted results because of motorists' widespread use of radar detection devices.
- 4 Laser Speed Meters.** Several manufacturers market speed meters that utilize laser beams. These devices emit pulses of coherent light with a short gap between pulses. The light beam is reflected by a moving vehicle and the device determines the distance the vehicle has traveled between successive pulses. Using the measured distance and the known time interval, the laser meter calculates speed. In comparison with radar, lasers emit a much narrower beam, and it is possible to measure the speed of any vehicle that the observer can see in the traffic stream.

## G. Data Analysis

Data from a spot speed survey are analyzed to determine central tendency and dispersion parameters. If the sample is large and was collected properly and without bias, the characteristics of the sample should be representative of the population. This section describes a typical analysis.

- 1 Data Set Description.** As shown in Table 6-1, the speeds of 110 free-flowing vehicles were monitored and recorded in 1.0 km/h increments; each ✓ represents one vehicle. While measuring and recording vehicle speeds, the data collector used a tally counter to count vehicles and ensure that a sample of at least 100 vehicles was obtained. At the conclusion of the data collection, the observer completed the  $f_i$  column, indicating the frequency of observations for each speed ( $u_i$ ).
- 2 Preliminary Calculations.** Entries in column (b), which are determined by successively adding  $f_i$  values from column (a) to the preceding total in column (b), represent the number of observations at or below any speed  $u_i$ . Entries in column (c) are obtained by multiplying each entry in column (a) by the corresponding value of the speed  $u_i$ , and entries in column (d) by multiplying each entry in column (c) by  $u_i$ . Columns (a), (c), and (d) are summed; the total of column (a) is the sample size,  $n$ . These calculations are easily performed with a spreadsheet.
- 3 Computation of Speed Parameters.** The results of the foregoing calculations are used to determine the following speed sample distribution parameters:
  - a. *Mean or Average Speed.* The arithmetic average speed, a measure of the central tendency of the data, is given by:

$$\bar{u} = \frac{\sum (f_i \bullet u_i)}{n} = \frac{5,295}{110} = 48.136 \text{ km/h} \quad [6.1]$$

The result may be rounded to 48.1 km/h for reporting purposes; however, the result to 3 decimal places must be used in Eq. 6.2.

- b. *Standard Deviation.* Although the mean is near the middle of all observations, Table 6-1 shows that there were no observations at 48.1 km/h, only 9 observations at 48 km/h, and a substantial spread in the remaining vehicle speeds. The standard deviation,  $s$ , is commonly used to quantify data dispersion; it has the same units (in this case, km/h) as the original data. It is calculated by determining the sample variance,  $s^2$ , and then taking the square root. For the data in Table 6-1:

$$s^2 = \frac{\sum (f_i \bullet u_i^2) - n \bullet \bar{u}^2}{n - 1} = \frac{257,947 - 110 \bullet 48.136^2}{110 - 1} = 28.15(\text{km/hr})^2 \quad [6.2]$$

and

$$s = \sqrt{s^2} = \sqrt{28.15} = 5.31 \text{ km/h} \quad [6.3]$$

**Table 6-1—Typical Speed Data Collection Form**

<b>SPOT SPEED SURVEY DATA FORM</b>															
Site <u>Pennsylvania SB at Phoenix</u> Speed Limit <u>50 km/h</u> Date <u>07/13/05</u> Data Collector <u>Bernie</u>															
Speed											(a)	(b)	(c)	(d)	
	5					10					$f_i$	$\sum f_i$	$f_i u_i$	$f_i u_i^2$	
35												0	0	0	0
36	✓	✓										2	2	72	2,592
37	✓											1	3	37	1,369
38	✓	✓	✓									3	6	114	4,332
39	✓	✓	✓	✓								4	10	156	6,084
40	✓											1	11	40	1,600
41	✓	✓	✓									3	14	123	5,043
42	✓	✓	✓									3	17	126	5,292
43	✓	✓										2	19	86	3,698
44	✓	✓	✓	✓	✓	✓	✓					7	26	308	13,552
45	✓	✓	✓	✓	✓	✓						6	32	270	12,150
46	✓	✓	✓	✓	✓							5	37	230	10,580
47	✓	✓	✓	✓	✓	✓	✓					7	443	291	5,463
48	✓	✓	✓	✓	✓	✓	✓	✓	✓			9	53	432	20,736
49	✓	✓	✓	✓	✓	✓	✓	✓	✓	✓	✓	12	65	588	28,812
50	✓	✓	✓	✓	✓	✓	✓	✓	✓	✓		10	75	500	25,000
51	✓	✓	✓	✓	✓	✓						6	81	306	15,606
52	✓	✓	✓	✓	✓	✓	✓	✓				8	89	416	21,632
53	✓	✓	✓	✓								4	93	212	11,236
54	✓	✓	✓	✓	✓	✓						6	99	324	17,496
55	✓	✓	✓	✓								4	103	220	12,100
56	✓	✓										2	10	511	26,272
57	✓											1	106	57	3,249
58	✓	✓										2	108	116	6,728
59	✓											1	109	59	3,481
60												0	109	0	0
61												0	109	0	0
62	✓											1	110	62	3,844
63												1	110	0	0
64												1	110	0	0
65												1	110	0	0
<b>Total</b>											110	0	5,295	257,947	

Speed data often approximate a normal distribution, where 68% of the observations are within one standard deviation of the mean ( $\bar{u} \pm s$ ), 95% within two standard deviations ( $\bar{u} \pm 2s$ ), and 99.8% within three standard deviations ( $\bar{u} \pm 3s$ ). The interested reader can verify that the speed data in Table 6-1 conform to this principle.

- c. *Standard Error of the Mean.* Even with proper data collection practices and the absence of bias, it is unreasonable to expect different samples from the same population to produce identical means. In fact, it is known that the means of different samples from the same population follow a normal distribution with a standard deviation of  $\sigma/\sqrt{n}$ , where  $\sigma$  is the standard deviation of the population; for large sample sizes,  $\sigma$  may be approximated by  $s$ , the sample standard deviation. The standard error of the mean,  $s_{\bar{u}}$ , is given by:

$$s_{\bar{u}} = \frac{s}{\sqrt{n}} = \frac{531}{\sqrt{110}} = 0.51 \text{ km/h} \quad [6.4]$$

- d. *Sample Sizes.* A speed sample's mean and standard deviation change relatively little with larger sample sizes. However, Eq. 6.4 demonstrates that the standard error of the sample mean, an indicator of the *reliability* of  $\bar{u}$  as an estimate of the population mean, can be made smaller by simply collecting a larger sample. If the engineer estimates the expected standard deviation of the speed based on previous studies at similar locations and specifies an acceptable standard error of the mean (as noted below,  $s_{\bar{u}} = 0.5 \text{ km/h}$  is reasonable), then Eq. 6.4 can be solved for an approximate sample size.

$$n = \frac{s^2}{s_{\bar{u}}^2} \quad [6.5]$$

- e. *Confidence Intervals.* The standard error of the mean can be used to define a range that has a specified probability of containing the true population mean. This range, referred to as a *confidence interval*, should be kept small ( $\bar{u} \pm 1 \text{ km/h}$ ) for trend studies and for before-and-after studies. For sample sizes greater than 30, the 95% confidence interval is approximately ( $\bar{u} \pm 2s$ , or 1 km/h if  $s_{\bar{u}}$  is about 0.5 km/h. For the speed data given in Table 6-1, the 95% confidence interval is 47.12 to 49.16 km/h. Confidence intervals for small samples are discussed in Appendix A.

Fig. 6-1 displays the initial 512 free-flowing speed measurements (in the order in which they were collected) from a rural, Interstate highway speed monitoring site. At every observation  $j$ , (for  $2 \leq j \leq 512$ ), the mean of the first  $j$  observations was calculated; the results, plotted as a solid line versus the left axis in the figure, show that this running mean was somewhat erratic over the first 50 measurements and stabilized near 107 km/h after about 100 measurements. The measured speed of 143 km/h at observation 142 had a small effect on the running mean.

The standard deviation for the first  $j$  observations was likewise calculated and plotted against the right axis in Fig. 6-1. After the first 100 observations, the standard deviation stays in a fairly narrow range of 7.7 to 8.8 km/h; however, it is clearly affected by unusually high (observation 142) or low speeds. The 95% confidence interval was calculated for each observation  $j$ , and the results are plotted as dashed lines immediately above and below the mean. The decrease in the standard error of the mean as the sample size increases results in a narrowing of the confidence interval. At  $j=25$ , the 95% confidence interval is 102.7 to 110.4 km/h; at  $j=100$ , it is 105.5 to 108.7; and at  $j=512$ , it is 107.6 to 109.0.

- f. *Before-and-After Studies.* Speed studies are performed to determine if a modification to highway design or traffic control has resulted in a significant change in operating speeds. Using field data, the mean,  $\bar{u}_b$ , standard deviation,  $s_b$ , and standard error of the mean,  $s_{\bar{u}_b}$ , are calculated for the before period, and the corresponding parameters,  $\bar{u}_a$ ,  $s_a$ ,  $s_{\bar{u}_a}$  for the after period. The standard deviation for the difference of the means is then calculated as:

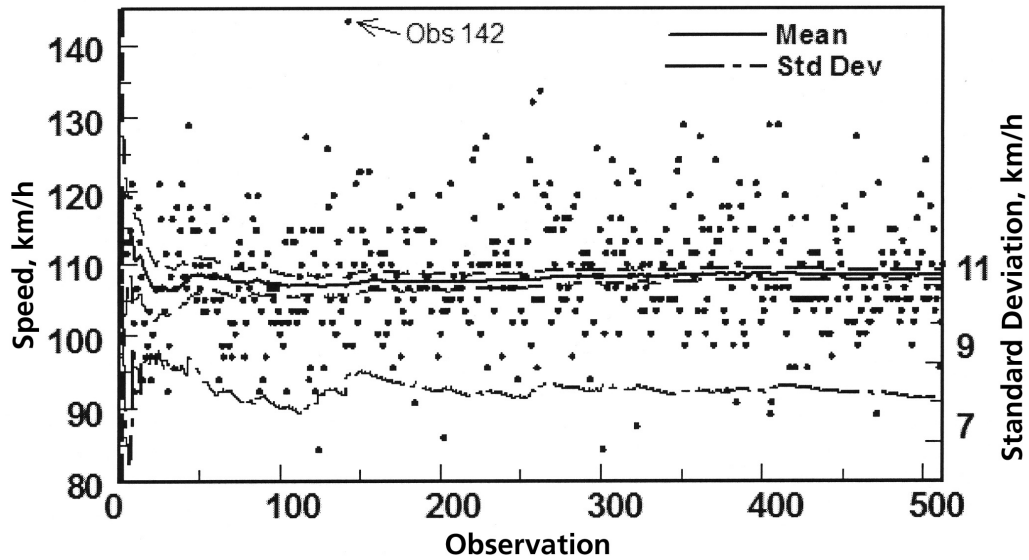

Fig. 6-1 – Mean, Standard Deviation, and Confidence Intervals

$$\hat{s} = \sqrt{s_{\bar{u}_b}^2 + s_{\bar{u}_a}^2} \tag{6.6}$$

where  $\hat{s}$  = standard deviation of the difference of the means. The difference between the before and after mean speeds is statistically significant if:

$$\bar{u}_b - \bar{u}_a > t_\alpha \hat{s} \tag{6.7}$$

where  $\alpha$  = level of significance (typically, 0.5)

$t_\alpha$  =  $(1-\alpha)$ <sup>th</sup> percentile of the  $t$  distribution with  $(n_a + n_b - 2)$  degrees of freedom.

The data set shown in Fig. 6-1 has a standard error of the mean of approximately 0.4 km/h. If  $s_{\bar{u}_a}$  for an after study at this location had a similar value, then  $\hat{s} \approx 0.6$ , and a difference between the means of only 1.2 km/h would be statistically significant at the 5% level of significance. The engineer must decide if a change of this magnitude is of practical significance.

g. *Distributions in Time and Space.* Chap. 4 referred to two types of speed: time-mean speed,  $\bar{u}_t$  and space-mean speed,  $\bar{u}_s$ . Spot speed studies, which are conducted at a point or over a very short segment, yield time-mean speeds; the mean speed from these studies can be determined using Eq. 6-1. Travel time studies (see Chap. 7) are conducted over extended sections of highway, and their measure of central tendency is expressed as a space-mean speed.

- (1) An example will highlight the difference. Assume that two vehicles are monitored at a spot speed study site, one traveling 30 km/h and the other 60 km/h. The time-mean speed is simply the average of these two values given by Eq. 6-1, or 45 km/h. Assume further that these same vehicles were being timed on a 15-km test route; the time required by the slower vehicle would be 0.5 h, that for the faster vehicle 0.25 h. Between the two of them, they traveled 30 km in a total of 0.75 h, for a space-mean speed of 40 km/h.
- (2) The difference can be appreciated by visualizing a section of road such as that used in the example. A spot speed study taken for a limited period at the end of the section will include some fast vehicles that had not entered the section at the beginning of the survey, but will exclude some slower vehicles that were in the section when the study started but did not reach the end of the section prior to the study's conclusion.

- (3) Except for the situation where all vehicles are traveling at the same speed, the time-mean speed will always be greater than the space-mean speed. As explained in Ref. 4, the approximate relationship between the two is expressed by:

$$\bar{u}_t = \bar{u}_s + \frac{s_s^2}{\bar{u}_s} \tag{6.8}$$

where  $s_s$  is the standard deviation of the space-mean speeds.

**4 Graphical Analyses.** Although discrete measures, such as the mean and standard deviation, provide a technical description of a speed distribution, a cumulative distribution of speeds provides a fuller appreciation of the spread of individual vehicle speeds. Typically, a graph is prepared of speed versus the percentage of vehicles traveling less than or equal to any speed. A cumulative graph for the speed data in Table 6-1, where the cumulative percentages are equal to  $\sum f_i/n$ , is shown in Fig. 6-2. The graph clearly shows the following parameters:

- a. *Median (50<sup>th</sup> Percentile) Speed* provides an alternative measure of a speed distribution's central tendency. By definition, half of the observed speeds are below the median, and the other half are above the median. It is readily identified as the 50% value on the cumulative speed distribution curve.
- b. *The 85<sup>th</sup> Percentile* of a spot speed distribution is often identified as  $P_{85}$  and is defined as that free-flow speed that only 15% of the motorists are exceeding. Because 85% of the motorists travel at or below this value, it is often considered in establishing the posted speed limit. The 85th percentile speed for the data in Table 6-1 is 53 km/h, only 3 km/h above the posted limit.
- c. *The Fifteen Kilometer per Hour Pace* provides an alternate, graphic method for describing speed data dispersion. It is defined as the 15 km/h range encompassing the largest number of speed observations and corresponds to the steepest part of the cumulative speed distribution curve. Consistency in travel speeds is evidenced by a pace that includes at least 80% of the free-flowing vehicles, with an upper boundary near the speed limit. In Fig. 6-2, 84% of the motorists were traveling in the 15 km/h pace beginning at 41 km/h.

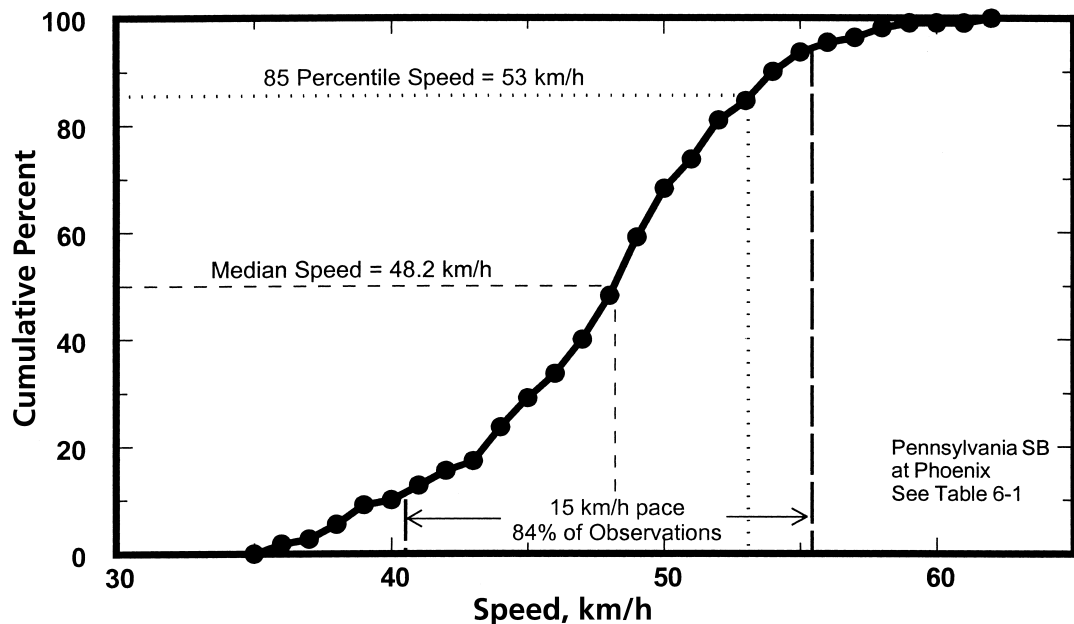

**Fig. 6-2 – Cumulative Speed Distribution Curve**

## H. Safe Curve Speed Study

- 1 The safe travel speed on a horizontal curve is a function of the radius of curvature, the roadway superelevation (see Chap. 17, Sec. C.), and driver and vehicle characteristics. If the safe speed on a curve is less than the posted speed limit, the motorist may be warned using a curve or turn sign, possibly together with an advisory speed sign. Ref. 5 provides guidelines for the use of these signs.
- 2 Safe curve speed is measured using a ball bank indicator. This unit is a hollow, curved tube filled with a ball and a damping fluid. The study is performed as follows:
  - a. A representative test vehicle (preferably not one with an extra-stiff suspension) is selected and the ball bank indicator is mounted on the dashboard. The unit is adjusted to read 0° when the vehicle is parked on a completely level surface.
  - b. The vehicle is driven through a horizontal curve at a constant speed; the speed for the initial run may be 10 or 20 km/h below the posted speed limit. The unbalanced centrifugal force causes the ball to move toward the outside of the curve, and the observer records the maximum reading obtained. If necessary, the study is repeated at higher speeds in 10 km/h increments; the field readings will increase with speed. Table 6.2 shows a typical safe curve speed data collection form.
  - c. Agencies specify various standards for the maximum acceptable readings. Typical criteria (Ref. 6) limit the ball bank indicator readings to 14° for speeds below 30 km/h, 12° for speeds between 35 and 60 km/h, and 10° for speeds above 60 km/h. FHWA (Ref. 6) examined ball bank indicator results and actual speeds driven by motorists on horizontal curves, and recommended increasing the standards to the following: 20° below 48 km/h, 16° between 48 and 64 km/h, and 12° above 64 km/h. The Caltrans *MUTCD* supplement (Ref. 7, Sec. 2C.101) specifies a limit of 16° for all speeds, and suggests that if a curve sign is warranted, an advisory speed warning should be posted.

**Table 6-2—Typical Safe Curve Speed Data Collection Form**

<b>SAFE CURVE SPEED FIELD FORM</b>						
Location <u>State Road 246, begin at mp 0.00</u>			Road Width <u>7.2 m</u>			
Date <u>8/28/2005</u>		Weather <u>Clear</u>		Travel Direction <u>NB</u>		
Posted Speed Limit <u>70 km/h</u>			Data Recorded By <u>Jane Engineer</u>			
Recommended Readings at Indicated Speeds		Field Readings				
		Curve 1	Curve 2	Curve 3	Curve 4	Curve 5
14°	10 km/h	2°		8°		
	20 km/h	6°	-1°	11°		
	30 km/h	9°	1°	14°	3°	
12°	40 km/h	11°	3°	17°	7°	
	50 km/h	13°	5°		10°	
	60 km/h	15°	7°		12°	
10°	70 km/h	18°	10°		14°	
	80 km/h		14°		17°	

## REFERENCES

1. Tignor, S.C. and D. Warren, "Driver Speed Behavior on U.S. Streets and Highways," *ITE Compendium of Technical Papers*, 1990, pp. 83-86.
2. Kell, J.H., I.J. Fullerton, and M.K. Mills. *Traffic Detector Handbook, Second Edition*. McLean, VA: Federal Highway Administration, 1990. 337 p.
3. Robertson, H. D., "Spot Speed Studies," *In: Manual of Transportation Engineering Studies*. Englewood Cliffs, NJ: Prentice-Hall, 1994. Chap. 3.
4. May, A. D. *Traffic Flow Fundamentals*. Englewood Cliffs, NJ: Prentice-Hall, 1990. 464 p.
5. Federal Highway Administration. *Manual on Uniform Traffic Control Devices for Streets and Highways – 2003, Rev 1*. Washington, DC: 2004 <http://mutcd.fhwa.dot.gov/pdfs/2003rl/pdf-index.htm>
6. Chowdhury, M.A., D. Warren, and H. Bissell. "Analysis of Advisory Speed Setting Criteria," *Public Roads*, Vol. 55, No. 3, December 1991, pp. 65-71.
7. California Department of Transportation. *MUTCD 2003 California Supplement*. Sacramento, CA: 2004. <http://www.dot.ca.gov/hq/traffops/signtech/mutcdsupp/supplement.htm>.





## A. Introduction

The traffic characteristics of flow rate, volume, and speed discussed in Chaps. 4-6 and the concept of level of service described in Chap. 8 are of major concern to the traffic engineer. These parameters, however, mean little to the typical driver, who is most often concerned with the time required to travel to a destination. Motorists have a general appreciation for the time required to make certain routine trips, and they will notice if the duration of their trip increases. Indeed, worsening urban traffic congestion may be the primary concern of both individual and commercial road users (Ref. 1). It is incumbent on the traffic engineer to monitor travel times on the street and highway network and to use this information in developing and prioritizing improvements.

## B. Definitions

- 1 **Travel Time Study.** A study conducted to ascertain the amount of time required to traverse a specific route or section of street or highway. The data permit the calculation of travel time and travel speed, but not necessarily delay. However, this term is frequently used to encompass both speed and delay studies.
- 2 **Delay Study.** This study determines the amount of delay experienced by motorists, typically at an intersection.
- 3 **Travel Time.** The total time required for a vehicle to travel from one point to another over a specified route under prevailing traffic conditions. Travel time includes the time a vehicle is stopped.
- 4 **Running Time.** The portion of the travel time during which a vehicle is actually in motion. Running time equals travel time minus stopped delay.
- 5 **Rate of Motion.** Travel time expressed in seconds per kilometer.
- 6 **Travel Speed.** The average space-mean speed along the specified section of a street or highway, computed by dividing total distance by travel time.
- 7 **Running Speed.** The average speed along a specified route for the period that a vehicle is actually in motion. Running speed is the total distance divided by running time.
- 8 **Delay.** The time lost due to traffic and control devices.
  - a. *Fixed Delay.* The delay that vehicles experience regardless of traffic volume and interference.
  - b. *Operational Delay.* The delay caused by other components of the traffic stream or congestion, parking maneuvers, pedestrians, and turning movements.

- c. *Stopped delay.* The time in a travel time study when the vehicle is stopped or traveling less than 8 km/h.
  - d. *Travel Time Delay.* The difference between time required to traverse a section of street or highway and the time corresponding to the average speed of traffic under unimpeded conditions. It includes stopped delay.
  - e. *Control Delay.* The component of delay that results from the control mode (e.g., traffic signal control) applied to a lane group, referenced to the uncontrolled condition.
- 9 **Delay Rate.** The difference between the observed and "acceptable" rates of motion for a particular facility type. While acceptable values differ among communities (Ref. 2), reasonable minimum peak-hour rates of motion might be:
- a. Freeway or Expressway — 60 s/km (60 km/h)
  - b. Major arterial — 90 s/km (40 km/h)
  - c. Collector — 120 s/km (30 km/h)
- 10 **Total Vehicle Delay.** The time lost, in vehicle•seconds per kilometer, by vehicles in a traffic stream because the street or section does not meet the suggested minimum standards. It is the product of the peak-hour one-direction volumes and the delay rate.
- 11 **Congestion.** The level at which transportation system performance is no longer acceptable due to traffic interference. This level varies by type of transportation facility, geographic location, and time of day.

### C. Need for Travel Time and Delay Data

- 1 **Congestion** can be evaluated by means of speed and delay studies. Data are obtained on the amount, location, and cause of delay; the delay data also suggest locations where supplemental studies are needed to determine the appropriate countermeasures.
- 2 **Traffic signal timing studies** (described in Chap. 16) and capacity analyses (see Chap. 8) often require travel time or speed data.
- 3 **Before-and-after studies** may utilize travel time and delay data to determine the effectiveness of a change such as parking prohibitions, signal timing revisions, or new one-way streets.
- 4 **Traffic assignment** to new or reconstructed roadways is based in part on travel times.
- 5 **Economic studies** (e.g., benefit-cost analyses) utilize travel time data. Vehicle operational patterns are also useful in estimating fuel consumption.
- 6 **Trend studies** utilize travel time data to evaluate changes in street and highway performance with the passage of time.

### D. Causes of Delay

- 1 **Fixed Delay** occurs primarily at intersections. This delay is not a result of the traffic stream flow characteristics and could occur with only a single vehicle traveling in the section. It may be caused, for example, by traffic signals, STOP signs, YIELD signs, or railroad crossing disruptions.
- 2 **Operational Delay** is caused by the presence of other traffic.
  - a. One type of operational delay is due to other traffic movements that interfere with the stream flow (side frictions), e.g., parking or unparking vehicles, turning vehicles, pedestrians, stalled vehicles, double parking, or cross traffic.
  - b. Internal frictions within the stream flow (see Chap. 4) are a second form of operational delay.

## E. Methods for Measuring Travel Time or Delay Data

- 1 **The Test Car Technique** (Ref. 4) utilizes a test vehicle that is driven over the street section in a series of "runs."
  - a. *Floating Car Method* describes one procedure used in driving the study route. The driver tries to "float" in the traffic stream by passing as many vehicles as pass the test vehicle. Strict application of this technique may result in erratic operation.
  - b. *Average Car Method* is a second driving technique. The driver is instructed to travel at a speed that is judged to be representative of the speed of all traffic at the time. This is most commonly used.
  - c. *Maximum-Car Technique* is a third technique. The test vehicle is driven at the posted speed limit unless impeded by traffic conditions or safety considerations.
  - d. *Delay Data* are frequently obtained using a test car technique.
  - e. *Test Routes and Checkpoints* are established in the field.
    - (1) Intermediate checkpoints should be used to help distinguish problem locations. They should be positioned to divide the route by its characteristics (e.g., changes in speed limit, number of lanes, or adjacent land use) into homogeneous sections.
    - (2) Because it is readily identifiable, the centerline of an intersecting street at a signalized intersection is normally a good checkpoint location. If other reference points are used, they must be unambiguous (obvious to different field data collectors), conspicuous (clearly visible to observers in an approaching test vehicle), and permanent (likely to be there if a subsequent study is conducted several years later).
    - (3) The test route length and the distances between checkpoints must be measured in both directions using a precision odometer or GPS technology. A sketch of the route and checkpoints is helpful to data collectors and serves as a part of the study documentation.
  - f. *Equipment Used* in performing test car travel time and delay studies.
    - (1) Traditionally, test runs require a two-person team, a driver and an observer, with the latter equipped with a pair of stopwatches (Ref. 4). The observer starts the travel time watch at the beginning of the run and records cumulative times at each checkpoint. A delay watch is used to measure the duration of individual stopped delay, for study purposes, at speeds below 8 km/h. Digital stopwatches minimize the opportunity for errors in data reading and recording.
    - (2) In traditional test car travel time studies, the observer records the times, along with the location and cause of delays, on a data collection form; voice recording equipment is an alternative. Specialized recording devices are available to eliminate the necessity of using two persons on test runs.
    - (3) Special software is now available for laptop computers or personal data assistants to measure and record the time at checkpoints and the duration of individual delays.
    - (4) Recently, laptop computers have been combined with GPS to permit a driver and test vehicle equipped with these devices to monitor and record travel time and delay data on a traditional test route. A study in Las Vegas used this method to identify problems with arterial signal coordination and suggest new timing that significantly reduced delay (Ref. 5). The researchers concluded that the minimal hardware and software costs were recouped after 18 hours of field study. Using similar tools, Atlanta completed travel time studies on 63 routes, each approximately 22 km long (Ref. 6).
  - g. *Analysis*. The analysis of travel time data and delay data from a series of test car runs is readily performed using a spreadsheet. Separate analyses should be conducted by travel direction for the morning peak period, evening peak period, and the off-peak periods.

- (1) Time and delay data are used to calculate travel running speeds for the entire test route and for individual sections between adjacent checkpoints. Sections exhibiting large differences between the travel and running speeds deserve further attention.
- (2) If the travel time for test run  $I$  is  $tt_i$  on a route of length  $l$  (km), the travel speed  $u_{si}$  (km/h) is given by:

$$u_{si} = \frac{3600 \bullet l}{tt_i} \quad [7.1]$$

If  $n$  test runs with travel times  $tt_1, tt_2, \dots, tt_n$  result in travel speeds of  $u_{s1}, u_{s2}, \dots, u_{sn}$ , then the average travel speed is given by:

$$\bar{u}_{si} = \frac{3600 \bullet n \bullet l}{\sum_{tt_i}} \quad [7.2]$$

For reasons discussed in Chap. 6, Sec. G.3.g, this result is not the same as  $\sum u_{si}/n$ .

- (3) The standard deviation and standard error of the mean of the travel and running speeds are calculated using Eqs. 6.3 through 6.6 in Chap. 6. Even with the elimination of the observer by using GPS technology, car runs remain expensive, and sample sizes are often small; 6 to 12 directional runs per time period are typical (see Appendix A, Sec. D). In these cases, the sample standard deviation  $s$  is not a good estimate of the population standard deviation  $s$ , and the standard error of the mean is therefore not a good estimate of the confidence limits of the sample mean. To adjust for small sample sizes, the error of the mean should be calculated as:

$$\epsilon = t_\alpha \bullet \frac{s}{\sqrt{n}} \quad [7.3]$$

where:  $\epsilon$  = error of the mean at the selected confidence level

$s$  = standard deviation of the speed sample

$t_\alpha$  =  $(1 - \alpha)$ <sup>th</sup> percentile value of the t distribution with  $(n-1)$  degrees of freedom

$\alpha$  =  $(1 - \text{selected confidence level})$

$n$  = sample size

Alternatively, the minimum sample size required for a specified maximum permissible error at a chosen confidence level can be estimated by solving Eq. 7.3 for  $n$ . Because  $t_\alpha$  varies with  $n$ , and the initial value of  $s$  must be estimated, the equation is solved iteratively. For example, if an error of the mean of 3 km/h is acceptable with a 95% confidence level, and if the expected standard deviation of the travel speeds is 4.3 km/h, a study with 10 travel time runs should be conducted.

The analysis of speeds in *before-and-after* travel time studies can be performed using the techniques presented in Chap. 6, Sec. G.3.f.

- h. **Data Presentation.** Travel time data can be summarized in tables. However, results may be more readily understood when presented in graphical formats.
  - (1) For a single route, a plot of travel speed versus distance between checkpoints highlights the problem locations.
  - (2) Area-wide travel speed data may be presented effectively on a color-coded map, with different colors indicating various peak-period travel speeds. An isochronal map, on which contours represent the distance traveled in fixed time intervals from a central reference point, is an alternate presentation technique.
- 2 **The License Plate Technique** is used to obtain larger samples when only travel time information is needed (Ref. 4).
  - a. *The License Plate Method* positions observers at each entrance and each exit of a test section where travel time is desired. The observers record the time and the last three or four numbers of the license plate of a sample of vehicles as they pass the observation point. The license numbers are matched in the office and the travel time (difference between the two recorded times) is determined. Computers simplify the matching of large amounts of data.

The procedure works best on roadway sections with relatively few entrances and exits. The major shortcoming of this technique is that it does not measure delay.

- b. *Equipment* commonly used in this technique includes:
    - (1) Synchronized stopwatches and data recording forms.
    - (2) Voice recorders with or without audible time signals.
    - (3) Laptop computers.
  - c. *Analysis.* The statistical analysis is the same as for spot speed studies. Sample sizes of 50 license number matches usually provide good accuracy (Ref. 4), but solving for  $n$  in Equation 7.3 above can determine the minimum sample size for a specific study site.
- 3 **The Photographic Technique** is primarily a research tool most useful in evaluating the interrelationships of several factors such as speeds, spacing, lane usage, acceleration rates, merging and crossing maneuvers, and delays at intersections. Traditionally this method has been restricted to short test sections; however, there is a potential for using the extensive video surveillance systems on many urban freeways for more elaborate studies.
  - 4 **The Interview Technique** may be useful when a large amount of information is needed in a short time period and at minimal expense. Usually the employees of strategically located firms (or the transportation agency) are asked to record their origin and travel time to or from work on a particular day. With good cooperation, the results obtained may be very satisfactory for the specific set of conditions under which the trips were made.
  - 5 **Real-Time Speed and Congestion** information is available from numerous sites on the internet. Although the primary purposes of this information are to facilitate freeway control and to advise motorists of traffic conditions, the information can also be used to monitor congestion. In a preliminary effort, real-time data from four jurisdictions with freeway surveillance systems were used to develop minute-by-minute statistics on speed and delay. (Ref. 7)

## F. Intersection Delay Studies

- 1 **Delay at Intersections** is a major source of motorist frustration. Delay studies at specific problem intersections (such as those highlighted in test car studies) are valuable in evaluating the efficiency or effectiveness of traffic control methods.
- 2 **Factors that Affect Delay at Intersections** include:
  - a. *Physical factors* such as the number and width of lanes, roadside obstructions, grades, access control, turning provisions, and transit stops.
  - b. *Traffic factors* such as volume, traffic composition, driver characteristics, turning movements, pedestrians, parking, and approach speeds.
  - c. *Traffic control* such as type and timing of signal controllers, interconnected system operations, STOP or YIELD signs, and parking controls.
- 3 **Methods of Intersection Delay Measurement** have evolved over the past 50 years (Refs. 8-9). Other than delay measurement in conjunction with a travel time study, the most common method has been to collect a systematic sample of the number of vehicles stopped on intersection approaches. Although this method is conceptually straightforward, results often differ from those obtained using a test vehicle. The *Highway Capacity Manual 2000* (Ref. 10) proposes the following refined method with two adjustment factors that provides a reliable estimate of control delay for a lane group.
  - a. Control delay per vehicle,  $d$ , is the average delay encountered by a vehicle approaching and exiting a signalized intersection in comparison with a situation where all vehicles on the approach travel unimpeded through the intersection at the normal speed on the street. The following information is needed to estimate control delay:
    - (1) Physical: number of lanes in the lane group,  $N$
    - (2) Operational: free-flow speed (km/h) of the approaching traffic,  $FFS$ ; traffic signal cycle length (s),  $C$

- (3) Volumes: total vehicles arriving during the study period,  $V_{tot}$ ; number of vehicles that stop due to the signal,  $V_{stop}$
  - (4) Interval: survey count interval (s),  $I_s$ , established by the analysts
  - (5) Queue: vehicle-in-queue counts (veh),  $V_{iq}$ , taken at the end of each count interval
- b. In most cases, two field observers are required to collect data; one will count traffic volumes while the other will monitor the number of vehicles in the queue. Data collection requires a time measuring device that could be a digital stop watch with a count-down-repeat timer or a laptop computer programmed to emit a sound at the end of each interval. The computer can be used in place of a data collection sheet to record vehicle-in-queue counts. A count board is needed to record total and stopping vehicles.
  - c. The physical and operational factors listed in E.3.a.(1) and (2) are readily determined through a review of existing records or limited field investigations.
  - d. The survey count interval,  $I_s$ , is determined prior to field vehicle-in-queue studies. If data collectors could actually monitor and record precise observations at the end of each interval, then shorter intervals (e.g., 1-2 s) would be preferred; because this is not feasible, intervals of 10-20 s are used to provide delay estimates. Whether the count interval is short or long,  $I_s$  must not be an integral divisor of the signal cycle. If  $C = 60$  s, then  $I_s$  could be 13 s or 17 s, but not 15 s. This requirement guarantees that field observations are not always taken at the same points in each signal cycle. If the intersection is controlled by an actuated signal with varying cycle lengths,  $I_s$  could be 15 s or another convenient duration.
  - e. Field data collection begins at the start of the red signal indication for the lane group under study and continues for an integer number of cycles or a predetermined time interval. At the study period's beginning, any vehicles stopped by the red signal that are left over from the previous cycle are excluded from the initial queue counts; in other words, only those vehicles that arrive after the study begins are included in the sample. A vehicle approaching the end of an existing queue is considered part of the queue when it reaches a point one car length from a stopped vehicle and is about to stop. Once a vehicle has joined the queue, it remains in the queue until it exits the intersection.
    - (1) A through vehicle exits the intersection when its rear axle crosses the stop bar (limit line).
    - (2) Vehicles turning onto the intersecting street exit the intersection when they have cleared opposing through traffic and pedestrians.
  - f. At intervals of  $I_s$ , the observer counts and records the number of vehicles in the queue. Table 7-1 shows a typical data collection form. The study began at 5 pm with no vehicles in the queue and the signal indication just turning red. At the end of the first 16-s interval, there was one vehicle in the queue; at the end of the second interval, there were 4 vehicles, consisting of the vehicle from the end of the first interval plus 3 new arrivals. At the end of interval 3, after 48 s, the queue includes 7 vehicles; 50 seconds into the study, the signal turns green and the queue begins to dissipate. At the end of the sixth 16-s interval, there are no vehicles in the queue; the signal turns red 4 s later. Fig. 7-1 is a schematic representation of the queues at the end of the first 6 intervals. As shown by Fig. 7-1, vehicles approaching within one vehicle-length of the queue end are included in the count.
  - g. Only those vehicles that enter the queue before the end of the study period (complete signal cycles or established time interval) are included in the survey. However, the study is not complete until each of these vehicles exits the intersection. Therefore, vehicle-in-queue and volume counts must continue until these vehicles exit.
  - h. Once field data collection has been completed, the data reduction involves the calculation of the parameters shown at the bottom of Table 7-1.
    - (1) Determine  $\sum V_{iq}$  by summing the columns and then row totals in Table 7-1.
    - (2) Estimate time-in-queue per vehicle as:

$$d_{vq} = 0.9 \cdot \left( I_s \cdot \sum V_{iq} / V_{tot} \right) \quad [7.4]$$

where the factor 0.9 adjusts for the fact that this sampling technique overestimates the operational delay.

**Table 7-1-Worksheet for Intersection Delay Study**

<b>INTERSECTION CONTROL DELAY WORKSHEET</b>								
Jurisdiction	<u>Albuquerque</u>	Observer	<u>Bridget</u>					
Intersection	<u>University at Rio Grande</u>	Study date	<u>07/11/05</u>					
<input type="checkbox"/> CBD <input type="checkbox"/> Other		Study time period	<u>Afternoon</u>					
Number of lanes, N	<u>1 NB</u>	Vehicles arriving, $V_{tot}$	<u>180</u>					
Free-flow speed, FFS	<u>50 km/h</u>	Vehicles stopped, $V_{stop}$	<u>80</u>					
Survey interval, $I_s$	<u>16 s</u>	Cycle length, C, s	<u>100 s</u>					
Clock Time	Cycle Number	Count Interval						
		1	2	3	4	5	6	7
5:00 pm	1	1	4	7	2	0	0	
	2	0	3	9	6	0	0	
	3	1	5	7	5	0	0	
	4	0	6	8	8	2	0	0
5:07	5	3	7	12	7	1	0	
	6	1	3	10	6	0	0	
	7	0	4	6	4	0	0	
	8	1	5	9	9	2	0	0
5:14	9	2	6	10	5	0	0	
	10							
Total		9	43	78	52	5	0	0
Total vehicles in queue, $\sum V_{iq}$		<u>187</u>		Number of cycles surveyed, $N_c$		<u>9</u>		
Time-in-queue/veh, $d_{vq} = 0.9 * (I_s * \sum V_{iq} / V_{tot})$		<u>15.0 s</u>		Fraction veh stopping, $FVS = V_{stop} / V_{tot}$		<u>0.44</u>		
Veh stopping/lane/cycle = $V_{stop} / (N_c * N)$		<u>9</u>		Accel/decel corr delay, $d_{ad} = FVS * CF$		<u>0.9 s</u>		
Accel/decel corr factor, CF		<u>2 s</u>		Control delay/veh, $d = d_{vq} + d_{ad}$		<u>15.9 s</u>		

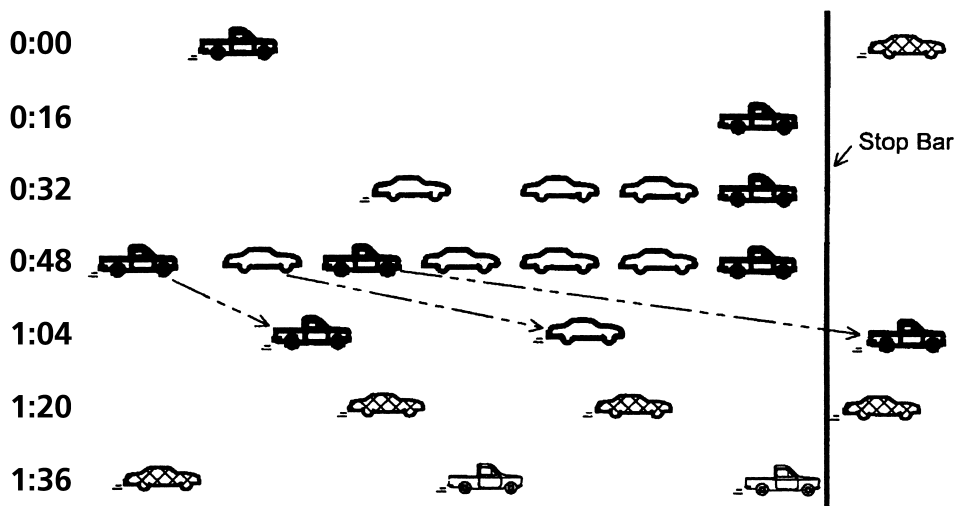

**Fig. 7-1-End-of-interval  $V_{iq}$  for the first six 16-s intervals shown in Table 7-1.**



- (3) The fraction of vehicles stopping and the number of vehicles stopping/lane/cycle are readily calculated from the field data.
- i. Field measurements using this survey method ignore the delay that motorists experience as they slow down on the intersection approach and as they accelerate exiting the intersection. These delay components cannot be easily measured in the field; the correction factors in Table 7-2, as a function of the street's free-flow speed and the average number of stopping vehicles, are applied to estimate control delay as shown by the calculations at the bottom of Table 7-1.

**Table 7-2—Acceleration/Deceleration delay correction factor, CF (s)**

Free-Flow Speed	Average Number of Stopping Vehicles/Lane/Cycle		
	≤7 Vehicles	8-19 Vehicles	20-30 Vehicles <sup>a</sup>
≤60 km/h	+5	+2	-1
>60-71	+7	+4	+2
>71	+9	+7	+5

<sup>a</sup> Vehicle-in-queue counts in excess of 30 vehicles per lane are typically unreliable.

- j. For the data presented in Table 7-1, the average time-in-queue is 15.0 s. Using the correction factors in Table 7-2 and the fraction of vehicles stopping, the average vehicle encounters an additional delay of 0.9 s while accelerating and decelerating. The control delay per vehicle is thus 15.9 s.

#### REFERENCES

1. Highway Users Federation. *Beyond Gridlock - The Future of Mobility as the Public Sees It*. Washington, DC: 1988. 80 pp.
2. Institute of Transportation Engineers. *A Toolbox for Alleviating Traffic Congestion*. Washington, DC: 1989. 154 pp.
3. Edwards, J.D., Jr. (Editor). *Transportation Planning Handbook*. Second Edition. Washington, DC: Institute of Transportation Engineers, 1999, Chap. 5.
4. Robertson, H. D., "Travel Time and Delay Studies," In: *Manual of Transportation Engineering Studies*. Englewood Cliffs, NJ: Prentice-Hall, 1994. Chap. 4.
5. Hawkins, E., "Driving FAST in Las Vegas – Using GPS for a Traffic Signal Timing Study." Preprint CD-ROM, 75th Annual meeting of the Institute of Transportation Engineers, District 6, Kalispell, MT, July 2005.
6. *Mobility 2030 - Model Documentation*, <http://www.atreg.com/transportationair/modeldocumentation.pdf>, Sec. 8.4, Atlanta, GA: December 2004.
7. Chin, Shih-Miao, et al. "Towards National Indicators of VMT and Congestion Based on Real-Time Traffic Data." Preprint CD-ROM, 78th Annual Meeting of the Transportation Research Board. Washington, DC, 1999.
8. Reilly, W.R., C.C. Gardner, and J.H. Kell. *A Technique for Measurement of Delay at Intersections*. Vol. 1—Technical Report. Vol. 2—Data Summaries. Vol. 3—User's Manual. Washington, DC: U.S. Federal Highway Administration, Reports FHWA-RD-76-135, 136, 137. Sept. 1976.
9. Berry, D.S., and C.J. Van Til, "A Comparison of Three Methods of Measuring Delay at Intersections." *Proceedings*, California Street and Highway Conference, 6th, 1954, pp. 71-79.
10. Transportation Research Board. *Highway Capacity Manual*, Fourth Edition. Washington, DC: 2000.

## A. Definitions

Definitions pertaining to the *Highway Capacity Manual* (Ref. 1) are shown below; reference is also made to definitions relating to the British method of calculating capacities (Ref. 2).

- 1 **Capacity.** The maximum sustainable flow rate at which vehicles or persons reasonably can be expected to traverse a point or uniform segment of a lane or roadway during a specified time period under given roadway, geometric, traffic, environmental, and control conditions; usually expressed as vehicles per hour, passenger cars per hour, or persons per hour.
- 2 **Prevailing Condition.** The geometric, traffic, and control conditions during the analysis period. Changes in these conditions may change the capacity of the facility.
  - a. *Geometric Condition.* The spatial characteristics of a facility, including approach grade, the number and width of lanes, lane use, and parking lanes.
  - b. *Traffic Condition.* A characteristic of traffic flow, including distribution of vehicle types in the traffic stream, directional distribution of traffic, lane use distribution of traffic, and type of driver population on a given facility.
  - c. *Control Condition.* The traffic controls and regulations in effect for a segment of street or highway, including the type, phasing, and timing of traffic signals; STOP signs; lane use and turn controls; and similar measures.
- 3 **Level of Service (LOS).** A qualitative measure describing operational conditions within a traffic stream, based on service measures such as speed and travel time, freedom to maneuver, traffic interruptions, comfort, and convenience.
- 4 **Service Flow Rate.** The maximum hourly rate at which vehicles (including bicycles) or persons can be reasonably expected to traverse a point or uniform section of a lane or roadway during a specified time period (usually 15 minutes) under prevailing conditions while maintaining a designated level of service, expressed as veh/h, persons/h, or veh/h/lane.
- 5 **Measure of Effectiveness.** A quantitative parameter indicating the performance of a transportation facility or service.
- 6 **Saturation Flow Rate.** The equivalent hourly rate at which previously queued vehicles can traverse an intersection approach under prevailing conditions, assuming that the green signal is available at all times and no lost times are experienced, expressed as veh/h or veh/h/lane.
- 7 **Lost Time.** The time during which the intersection is not used effectively by any movement, clearance lost time plus start-up lost time. Probably a little greater than 2 seconds per phase in the U.S. Can be obtained from field studies.
- 8 **Effective Green Time.** The time during which a given traffic movement or set of movements may proceed. It is equal to the cycle length minus the effective red time.

- 9 **Effective Red Time.** The time during which a given traffic movement or set of movements is directed to stop. It is equal to the cycle length minus the effective green time.
- 10 **Passenger Car Equivalent.** The number of passenger cars displaced by a single heavy vehicle of a particular type under specified roadway, traffic, and control conditions. After converting non-passenger vehicles using the equivalent factor, volumes are expressed in terms of passenger car units (pcu). See E.2. below.
- 11 **Density.** The number of vehicles on a roadway segment averaged over space, usually expressed as vehicles per kilometer or vehicles per kilometer per lane.
- 12 **Free-Flow Speed.**
- The theoretical speed of traffic, in km/h, when density is zero, that is, when no vehicles are present.
  - The average speed of traffic over an urban street segment without signalized intersections, under conditions of low volume.
  - The average speed of traffic consisting solely of passenger cars over a basic freeway or multilane highway segment under conditions of low volume.
- 13 **Base Condition.** The best possible characteristic in terms of capacity for a given type of transportation facility; that is, further improvements would not increase capacity; a condition without hindrances or delays.

**Table 8-1—Service Measures in HCM 2000**

Facility	Chapter <sup>a</sup>	Service Measure <sup>b</sup>
<b>Vehicular</b>		
Interrupted Flow		
Urban street	15	speed
Signalized intersection	16	delay
Two-way stop intersection	17	delay
All-way stop intersection	17	delay
Roundabout	17	c
Interchange ramp terminal	26	delay
Uninterrupted Flow		
Two-lane highway	20	speed, percent time-spent-following
Multilane highway	21	density
Freeway - basic segment	23	density
ramp merge	25	density
ramp diverge	25	density
weaving	24	speed
<b>Other Road Users</b>		
Transit	27	d
Pedestrian	18	space, delay
Bicycle	19	event, delay

- a - Only Part III chapters are listed. When performing planning level analyses, the analyst should refer to Part II for further guidelines and for selection of default values.
- b - The service measure for a given facility type is the primary performance measure and determines the level of service.
- c - *HCM* does not include a method for estimating performance measures for roundabouts. Non-*HCM* models that produce a delay estimate must be employed.
- d - Several measures capture the multidimensional nature of transit performance when defining LOS; see *HCM* Chap. 27 and Ref. 3.

Source: Adapted from Ref. 1.

## B. Roadway Capacity (Ref. 1)

- 1 **Levels of Service.** Traffic flow conditions ranging from "base" to breakdown have been divided into six levels of service (LOS) for qualitative evaluation of uninterrupted flow on multilane highways. (A similar set of definitions exists for freeways.)
  - a. *Level A* — free flow, low volumes and densities, high speeds. Drivers can maintain their desired speeds with little or no delay and are unaffected by other vehicles.
  - b. *Level B* — reasonably free flow, operating speeds beginning to be restricted somewhat by traffic conditions. Drivers still have reasonable freedom to select their speed.
  - c. *Level C* — speeds remain near free-flow, but freedom to maneuver is noticeably restricted.
  - d. *Level D* — speed begins to decline with increasing volume. Freedom to maneuver is further reduced, and the traffic stream has little space to absorb disruptions.
  - e. *Level E* — unstable flow with volume at or near capacity. Freedom to maneuver is extremely limited, and level of comfort afforded the driver is poor.
  - f. *Level F* — breakdown in flow. Both speeds and volumes can drop to zero.
- 2 **Service Measures.** For each facility type a service measure is used to define the operating level of service. Table 8-1 lists the service measures.
- 3 **Flow Rates Under Base Conditions.** The maximum service flow rates on freeways and multilane highways under base conditions for LOS A through E are given in Table 8-2. Level E corresponds to capacity. However, flow rates exceeding those shown in this table have been reported in special situations.

**Table 8-2—Maximum Service Flow Rates for Freeways and Multilane Highways**

Free-Flow Speed (km/h)	Service Maximum Flow Rate (pc/h/ln)				
	A	B	C	D	E
<b>Freeways</b>					
120	840	1320	1840	2200	2400
110	770	1210	1740	2135	2350
100	700	1100	1600	2065	2300
90	630	990	1440	1955	2250
<b>Multilane Highways</b>					
100	700	1100	1575	2015	2200
90	630	990	1435	1860	2100
80	560	880	1280	1705	2000
70	490	770	1120	1530	1900

Source: Ref. 1

Base conditions for uninterrupted flow facilities are defined to include:

- a. 3.6-m traffic lanes, no obstruction within 1.8 m of the edge of pavement.
  - b. Level terrain. Horizontal and vertical alignment satisfactory for free-flow speeds of 120 km/h on freeways and 100 km/h on multilane highways.
  - c. Only passenger cars in the traffic stream.
- 4 **Factors Affecting Capacity and Service Volumes.** Capacity and service flow rates on freeways and multilane highways are affected by any factor which modifies base conditions. The effect of each modification is shown in the appropriate chapter of Ref. 1 as an adjustment to be applied to the maximum service flow rate or to the free-flow speed. A partial list of these factors follows.

a. *Roadway Factors:*

- (1) Lane width.
- (2) Lateral clearance.
- (3) Horizontal and vertical alignment.
- (4) Access point density.
- (5) Interchange density
- (6) Median type
- (7) Number of lanes

b. *Traffic Factors*

- (1) Free-flow speed.
- (2) Peak hour factor
- (3) Heavy vehicles.

- 5 **Capacity of Two-Lane Highways.** (*HCM* Chap. 20) Two-lane highways' operating characteristics differ from those of multilane highways, due principally to vehicles overtaking and passing slower-moving vehicles by using the lane designated for opposing traffic. Capacity for two-lane highways is usually expressed as the total for both directions of travel and ranges from 3,200 to 3,400 pc/h.

Service measures include "percent time spent following" (PTSF) and average travel speed. Both measures are considered when analyzing Class I highways, while only percent time spent following is used for Class II highways. Class I facilities are relatively high speed and serve longer trips. Class II facilities serve shorter trips. The proportion of all vehicles that travel at headways shorter than 3 seconds is considered a reasonable estimate of the measure "percent time spent following." Table 8-3 lists the criteria for LOS on two-lane highways. Note that for Class I highways, both service measures must be met for operations to fall within a given level of service.

**Table 8-3—LOS Criteria for Class I and Class II Two-Lane Highways**

LOS	Class I		Class II
	PTSF	Average Travel Speed (km/h)	PTSF
A	≤ 35	> 90	≤ 40
B	> 35–50	> 80–90	> 40–55
C	> 50–65	> 70–80	> 55–70
D	> 65–80	> 60–70	> 70–85
E	> 80	≤ 60	> 85

Source: Ref. 1.

Free-flow speed along two-lane highways is affected by lane and shoulder widths and access points such as driveways. Flow rate is affected by peak-hour factor, grade, and heavy vehicles. Finally, "percent no passing" is used in the analysis procedures and refers to the proportion of the analysis segment length with passing sight distance of 300 m or less.

The procedures for analysis of two-lane highways allow for determination of both capacity and level of service for one direction of flow and for both directions combined.

### C. Freeway Capacity

The *HCM 2000* divides freeway analysis into four chapters as described below:

- 1 **Basic Freeway Segments** (*HCM* Chap. 23). This chapter deals with segments of freeways beyond the influence of ramps or weaving sections. LOS and the service measure of density are defined as in the middle column of Table 8-4:

All service flow rates are expressed as maximum flow rates that can be accommodated in a peak 15-minute period. Flow rates are adjusted for the effect of narrow lanes or reduced lateral clearances, heavy vehicles, and for driver population (e.g., commuter, recreational).

- 2 **Freeway Weaving** (*HCM* Chap. 24). The weaving procedure chapter deals with three geometric measurements that affect traffic operations in weaving areas—length, number of lanes (width), and configuration. There are three types of weaving configurations:
  - a. *Type A* weaving configurations require each weaving vehicle to make one lane change to successfully complete its maneuver.

- b. *Type B* weaving configurations have one weaving movement that can be accomplished without a lane change; the other weaving movement requires only one lane change.
- c. *Type C* weaving configurations have one weaving movement that can be completed without a lane change; however, the other weaving movement requires two or more lane changes.

The procedure allows for estimation of LOS (based on density), the average speed for both weaving and non-weaving traffic streams, and capacity. The ranges of density for each level of service are shown in the last column of Table 8-4. Also, *HCM 2000* provides guidelines for estimating LOS of weaving segments on multilane arterials.

**3 Ramps and Ramp Junctions** (*HCM* Chap. 25). This chapter covers the ramp-freeway junction and the ramp roadway.

For ramp-freeway junctions (both merge and diverge), the primary measure for identifying levels of service is "maximum density" in units of pc/km/ln. The ranges of density for each level of service are shown in Table 8-4.

**Table 8-4 LOS Criteria for Freeway**

Level of Service	Density Range (pc/km/ln)		
	Freeway Segments	Ramp and Ramp Junctions	Freeway Weaving Segments
A	0-7	0-6	0-6
B	> 7-11	> 6-12	> 6-12
C	> 11-16	> 12-17	> 12-17
D	> 16-22	> 17-22	> 17-22
E	> 22-28	> 22	> 22-27
F	> 28	Demand > Capacity	> 27

Source : Ref 1.

For ramp roadways, approximate capacities of 2,200 and 1,800 pc/h are indicated for single-lane ramps with free-flow speeds greater than 80 km/h and less than 30 km/h respectively.

**4 Freeway Facilities** (*HCM* Chap. 22). This chapter combines basic freeway segments, weaving segments, and ramp junctions to provide a comprehensive analysis of the total length of freeway under consideration. The methodology provides estimates of speed, travel time, density flow rate, and volume-to-capacity ratio. The estimates are for each cell in a time-distance matrix used for analysis. LOS on a facility-wide basis is not used in the method.

**D. Signalized Intersections** (*HCM* Chap. 16)

The *HCM 2000* provides procedures for calculating signalized intersection capacities and levels of service.

- 1 **Methodology.** The procedures are based on the analysis of critical movements. Each approach lane or group of lanes is analyzed separately. Those lanes or groups which control the allocation of green time are identified.
- 2 **Levels of Service.** The service measure used to define LOS is control delay. Control delay is the delay experienced by vehicles while decelerating to join a queue, while in the queue (this portion of control delay is called stopped delay), and while accelerating to regain desired speed. The relationship between control delay and stopped delay will vary depending on many factors. An average or typical condition of control delay being 30 percent greater than stopped delay was found in research sponsored by FHWA (Ref. 4). LOS for signalized intersections are shown in Table 8-5.
- 3 **Capacity vs. LOS.** Intersection capacity is not as clearly related to LOS as in the case of other facilities. Delays in the LOS F range may occur at volume/capacity (v/c) ratios that are

**Table 8-5—LOS Criteria for Signalized Intersections**

LOS	Control Delay (s/veh)
A	≤10
B	> 10–20
C	> 20–35
D	> 35–55
E	> 55–80
F	> 80

Source: Ref. 1.

well below 1.0, e.g., where the cycle length is long, the lane group has a long red interval, and/or signal progression is poor. Conversely, a saturated lane group ( $v/c = 1.0$ ) may have low delay (better LOS) if the cycle length is short, or progression is favorable.

- 4 **Analysis Method.** The methodology requires detailed information on geometric, traffic, and signalization conditions at the intersection. Because this process is complex, it has been divided into five modules.
  - a. *Input Parameters.* This module comprises all the basic input data required.
  - b. *Lane Grouping and Demand Flow Rate Module.* In this module, the lane groups are defined and flow rates for peak 15-minute analysis periods are determined.
  - c. *Saturation Flow Rate Module.* Saturation flow for each lane group is adjusted for the number of lanes, lane width, proportion of heavy vehicles, approach grade, parking lanes and parking activity, local buses stopping at the intersection, area type, lane utilization, proportion of right and left turns, and pedestrian and bicycle activity.
  - d. *Capacity and  $v/c$  Module.* This module computes the capacity and  $v/c$  ratio for each lane group. The results are aggregated to determine the  $v/c$  ratio for the intersection as a whole.
  - e. *Performance Measure Module.* Average control delay is computed for each lane group, then aggregated for each approach as well as for the entire intersection. LOS are then determined.
- 5 **Computations.** The analysis is quite comprehensive. Worksheets are available to assist in manual calculations. However, the calculations are time-consuming. Various personal computer software programs are available to assist the analyst.
- 6 **Other Procedures.** A method developed in Australia (Refs. 5 and 6) provides estimates of a number of performance measures, including queue length. Some agencies require the use of the critical movement analysis method (Ref. 7). Others (especially in Southern California) prefer the Intersection Capacity Utilization method (Ref. 8).

## E. Signalized Intersection Capacity—British Method

The Road Research Laboratory (now the Transport Research Laboratory) of the U.K. has done considerable research in the field of capacity (Ref. 2). While the results obtained for roadway capacities have little relevance to U.S. conditions, those for intersection capacity are useful both for the parameter values themselves and for the analysis used. The analysis is similar to the 1965 *Highway Capacity Manual* procedure in that a basic value for saturation flow is obtained and modified to account for certain operational characteristics.

- 1 **Saturation Flow Related to Approach Width.** The relationship between the width of the approach,  $w$ , and saturation flow,  $s$ , is as follows ("pcu" refers to passenger car units):

$w$	> 5.2 m	$s$	= 525 * $w$ pcu/h of effective green
	= 5.2 m		= 2700 pcu/h of effective green
	= 4.6 m		= 2250 pcu/h of effective green
	= 4.0 m		= 1950 pcu/h of effective green
	= 3.0 m		= 1850 pcu/h of effective green

- 2 **Effect of Composition of Traffic.** The effect of large vehicles, motorcycles, and bicycles is accounted for by making the following conversions to pcu:

1 passenger car or light commercial vehicle	= 1.00 pcu
1 heavy or medium commercial vehicle	= 1.75 pcu
1 bus	= 2.25 pcu
1 motorcycle	= 0.33 pcu
1 bicycle	= 0.20 pcu

(Note: These equivalencies apply only to signalized intersections. For passenger-car unit (pcu) conversion in rural and urban highway analysts, see Ref. 7, p. 201).

- 3 **Effect of Left-Turning Vehicles.** Left-turning vehicles which must cross an opposing traffic stream are allowed for by the equation:

$$1 \text{ left turning vehicle} = 1.75 \text{ straight-ahead vehicles.}$$

This represents their effect on traffic in the approach from which they are turning. Vehicles attempting to make a left turn and caught within the intersection at the end of the signal phase are expected to discharge at headways of 2.5 s and delay the cross street traffic accordingly. (An assumption is that right-turn movements do not reduce saturation flow.)

- 4 **Effect of Parked Vehicles.** The reduction in saturation flow depends on the distance the first parked vehicle is from the stop line. The effect is expressed as a loss of available roadway width in the approach by the equation:

$$\text{Loss of roadway width (m)} = 1.68 - \frac{0.9(z - 7.6)}{k} \quad [8.1]$$

where  $z$  = the distance from the parked car to the stop line, but if  $z < 7.6$  m, use  $z = 7.6$  m (loss of width = 1.68 m);

$k$  = green time in s.

If the entire expression becomes negative, loss of width = 0.

- 5 **Effect of Grade.** For downgrades up to 5% on the approach, increase saturation flow value by three times the grade percentage; for upgrades up to 10%, decrease the saturation flow value by three times the grade percentage.
- 6 **Effect of Locality.** The values and factors given above are based on traffic observations in "average" localities in urban areas. Saturation flow may be 20% higher at "good" sites, where there are no visibility restrictions, alignment is good, there are no bottlenecks in the exits from the intersection, and no pedestrians cross. It may be 15% lower at "bad" locations where visibility is severely restricted, alignment is bad, there are obstructions in the exit roadways, or there is considerable pedestrian interference.

#### 7 Sample Calculation (British Method) for Saturation Flow in One Approach.

Given:	Approach width	9.15 m
	Approach grade	2% up
	Heavy/medium commercial vehicles	10%
	Buses	1%
	Left turns across opposing traffic	5%
	Parked vehicles from stop line	10.7 m
	Signal cycle	G-26 s, Y-4 s, R-30 s
	Locality	"Average"
	Lost time	3 s/phase



- a. Adjust for parked vehicles:  
 Loss of roadway width =  $1.68 - \frac{0.9 \cdot (10.7 - 7.6)}{26} = 1.57\text{m}$
- Effective approach roadway width =  $9.15 - 1.57 = 7.58\text{ m}$ .
- b. Calculate initial saturation flow figure:  
 $s = 525 \cdot 7.58 = 3980\text{ pcu/h}$  of effective green
- c. Adjust for commercial vehicles and buses:  
 $100\text{ vehicles} = 89 \cdot 1.00 + 10 \cdot 1.75 + 1 \cdot 2.25 = 108.75\text{ straight-ahead vehicles}$ .  
 Saturation flow =  $\frac{3980}{108.75} \cdot 100 = 3660\text{ straight-ahead veh/h}$  of effective green.
- d. Adjust for left-turning vehicles across opposing traffic:  
 $100\text{ total vehicles} = 95 \cdot 1.00 + 5 \cdot 1.75 = 103.75\text{ straight-ahead vehicles}$   
 Saturation flow =  $\frac{3660}{103.75} \cdot 100 = 3528\text{ straight-ahead veh/h}$  of effective green.
- e. Adjust for grade-correction is  $3 \cdot -2\% = -6\%$ :  
 Corrected saturation flow =  $3528 \cdot .94 = 3316\text{ veh/h}$  of effective green.
- f. Compute flow per hour:  
 Effective green time =  $26 + 4 - 3 = 27\text{ s}$   
 Proportion of effective green time to total time =  $\frac{27}{60} = .45$   
 Capacity =  $3316 \cdot .45 = 1492\text{ vehicles/h}$

- 8 **Effect of Cycle Length on Capacity.** The concept of "lost time" in each phase suggests that reduction of the frequency of phase changes by increasing total cycle length will increase capacity. In the preceding example, had the cycle length been 120 s, with G-56 s, Y-4 s, R-60 s, step f. of the calculation would have shown:

$$\text{Effective green time} = 56 + 4 - 3 = 57\text{ s}$$

$$\text{Proportion of effective green to total time} = \frac{57}{120} = 0.475$$

$$\text{Capacity} = 3316 \cdot 0.475 = 1575\text{ vehicles/h, or an increase of 5.6\% above the previous result.}$$

## F. Unsignalized Intersections (*HCM* Chap. 17)

Although unsignalized intersections comprise the majority of at-grade intersections in any street system, they are seldom a capacity problem. Normally they will have been signalized before they do become a problem. However, Chap. 17 of the *HCM 2000* contains procedures for analysis of two-way stop-controlled (TWSC) and all-way stop-controlled (AWSC) intersections. Neither procedure is intended for analysis of completely uncontrolled intersections. Chap. 17 of the *HCM* also includes a brief description of operations at roundabouts.

- 1 **Two-Way Stop Control.** The TWSC procedure defines LOS as a function of average control delay on the minor street approaches. The method also provides for estimating queue lengths on minor street approaches. The delay ranges for both TWSC and AWSC analyses are shown in Table 8-6.

The procedure is based on an assignment of priority order (rank) to the conflicting traffic streams:

- Through vehicles and right turns from the major street.
- Left turns from the major street and right turns onto the major street.
- Through vehicles on the minor street and (at T intersections) left turns from the minor street.
- Left turns from the minor street.

**Table 8-6—LOS Criteria for Two-Way Stop Control**

LOS	Control Delay (s/veh)
A	0–10
B	> 10–15
C	> 15–25
D	> 25–35
E	> 35–50
F	> 50

Source: Ref. 1.

A potential capacity is determined for each movement and the impedance to any given movement created by other conflicting movements is determined. Also, conditions where a single shared lane carries two or three movements are accounted for.

- All-Way Stop Control.** Unlike the TWSC procedure, which has its origin in methods used in Germany, the AWSC procedure is based on research conducted in the U.S. in the 1990s. Each intersection approach is analyzed independently, the basic parameter being the departure headway of vehicles once they have come to a full stop. The average control delay establishes the LOS (see TWSC definitions above).
- Roundabout.** The *HCM 2000* provides for estimating the capacity of a single-lane roundabout approach. The capacity is dependent on several factors, including the amount of circulating flow within the roundabout.

### G. Urban Streets (*HCM* Chap. 15)

*HCM* Chap. 15 evaluates existing operations or a design proposal by estimating LOS for a significant length of urban street. Capacity estimation for the urban street is not part of this method.

The street is first assigned to one of four classes. Each class has a range of free-flow speeds under which it operates. The running time is estimated as well as the control delay at signalized intersections, using the procedures of *HCM* Chap. 16. Combining the running time and the delay provides for an estimate of average travel speed, which in turn defines LOS.

### H. Pedestrians (*HCM* Chap. 18); see also Chap. 20.

- Walkways and Sidewalks.** The primary performance measure is space, in  $\text{m}^2/\text{p}$ . Table 8-7 shows the range of values for space, flow rate, and walking speed for each level of service.

**Table 8-7—LOS Criteria for Walkways and Sidewalks**

LOS	Space ( $\text{m}^2/\text{p}$ )	Flow Rate (p/min/m)	Speed (m/s)
A	> 5.6	$\leq 16$	> 1.30
B	> 3.7–5.6	> 16–23	> 1.27–1.30
C	> 2.2–3.7	> 23–33	> 1.22–1.27
D	> 1.4–2.2	> 33–49	> 1.14–1.22
E	> 0.75–1.4	> 49–75	> 0.75–1.14
F	$\leq 0.75$	Variable	$\leq 0.75$

Source : Ref. 1.

- Pedestrian Queuing Areas.** The methods allow estimating LOS for a queuing area based on space per pedestrian. Table 8-8 lists the range of pedestrian space for each LOS.
- Shared Pedestrian-Bicycle Facilities.** Chap. 18 of the *HCM* includes LOS criteria based on the concept of "event," for pedestrians using shared facilities. Bicycles that either oppose or pass a pedestrian are counted as an "event." As the number of events per hour increases, the pedestrian LOS decreases.

- 4 **Pedestrian Crosswalks.** Average pedestrian delay is used as the service measure defining LOS at both signalized and unsignalized intersections. Delay is also an indicator of how well pedestrians will comply with signal indications. Risk-taking by pedestrians has been observed to increase rapidly when delays exceed 30 s per pedestrian.

**Table 8-8—LOS Criteria for Pedestrian Queuing**

LOS	Space (m <sup>2</sup> /p)
A	> 1.2
B	> 0.9–1.2
C	> 0.6–0.9
D	> 0.3–0.6
E	> 0.2–0.3
F	≤ 0.2

Source: Ref. 1.

### I. Bicycles (*HCM* Chap. 19) See also Chap. 21.

This *HCM* chapter has analysis procedures for five types of bicycle facilities.

- 1 **Exclusive Off-Street Paths.** The concept of "events" is used for estimating LOS. An "event" occurs when a bicycle either passes or meets another bicycle. Table 8-9 gives the criteria.

**Table 8-9—LOS Criteria for Exclusive Bicycle Paths**

LOS	Frequency of Events, 2-Way, 2-Lane Paths <sup>a</sup> (events/h)	Frequency of Events, 2-Way, 3-Lane Paths <sup>b</sup> (events/h)
A	≤ 40	≤ 90
B	> 40–60	> 90–140
C	> 60–100	> 140–210
D	> 100–150	> 210–300
E	> 150–195	> 300–375
F	> 195	> 375

Source: Ref. 1.

a. 2.4-m-wide paths. Also used for on-street bicycle lanes.

b. 3.0-m-wide paths.

- 2 **Shared Off-Street Paths.** Paths that carry both bicycles and pedestrians are considered to be "shared." Criteria in terms of frequency of events are used to estimate LOS.
- 3 **On-Street Bicycle Lanes.** These lanes are separated from motor vehicles by striping or other devices. General guidelines for LOS are given, based on bicycle speeds. The variation (standard deviation) in speeds around the mean bicycle speed is considered in the guidelines.
- 4 **Bicycle Lanes at Signalized Intersections.** LOS for bicycles at traffic signals are based on the control delay incurred by bicyclists. Table 8-10 lists the criteria.

**Table 8-10—LOS for Bicycles at Signalized Intersections**

LOS	Control Delay (s/bicycle)
A	< 10
B	≤ 10–20
C	> 20–30
D	> 30–40
E	> 40–60
F	> 60

Source: Ref. 1.

- 5 **Bicycle Lanes on Urban Streets.** Average travel speed (km/h) of bicycles is the service measure for determining LOS. Table 8-11 lists the criteria.

**Table 8-11—LOS Criteria for Bicycle Lanes on Urban Streets**

LOS	Bicycle Travel Speed (km/h)
A	> 22
B	> 15–22
C	> 11–15
D	> 8–11
E	≤ 7–8
F	< 7

Source: Ref. 1.

#### REFERENCES

1. Transportation Research Board, *Highway Capacity Manual*, National Research Council. Washington, DC: 2000.
2. Great Britain, Road Research Laboratory. *Research on Road Traffic*. London: Her Majesty's Stationery Office, 1965. Chapter 6.
3. Transportation Research Board. *Transit Capacity and Quality of Service Manual*, 2nd Edition. National Research Council. Washington, DC: 2003.
4. Reilly, W. R., C. C. Gardner, and J. H. Kell. *A Technique for Measurement of Delay at Intersections*. FHWA Report No. RD-76-135/137, FHWA, Washington, D.C., 1976.
5. Akcelik, R. "SIDRA as an Advanced Traffic Signal Analysis Method for the Highway Capacity Manual" *REAAA Journal*. No. 1, Jan. 1993, pp. 21-31.
6. Akcelik, R., M. Besley, and R. Roper. *Fundamental Relationships for Traffic Flows at Signalized Intersections*. ARRB Report ARR 340, ARRB, Victoria, Australia, 1999.
7. Transportation Research Board, Committee on Highway Capacity and Quality of Service. *Transportation Research Circular 212*. Washington, DC: Jan. 1980, 272 p.
8. Crommelin, R.W. "Employing Intersection Capacity Utilization Values to Estimate Overall Level of Service." *Traffic Engineering*. v. 44, n. 10, July 1974, pp. 11-14.



## A. Introduction

"An accident is a rare, random, multifactor event, preceded by a situation in which one or more persons failed to cope with their environment." (United Kingdom. *Accident Investigational Manual*. 1986) In the aggregate, however, traffic accidents are numerous and often follow certain patterns that can be identified. Accidents reflect a shortcoming in one or more components of the driver-vehicle-roadway system. It is therefore important for engineers having responsibility for the design and operation of streets and highways to monitor traffic accident experience and to use this information in the planning, implementation, and evaluation of corrective action. Subsequent sections of this chapter describe the state of highway safety in the United States and California and provide guidelines for the proper analysis of accident data.

### 1 **Objectives of Accident Analysis.**

- a. To identify high-accident locations for detailed study (see Sec. E below).
- b. To improve geometric, traffic control, and operational conditions that contribute to the frequency or severity of collisions.
- c. To determine the effectiveness of different designs, controls, and other countermeasures.
- d. To evaluate the cost-effectiveness of safety programs.
- e. To provide a database for future traffic accident reduction efforts.

2 **Accident Data Quality.** Data are normally collected by enforcement officers at the scene of an accident. Although the completeness and accuracy of the data vary among officers, the quality of those data elements relevant to the traffic engineer (e.g., crash location, manner of collision, existence of highway defects) is below the standards employed in the collection of engineering data. In addition, a significant but unknown proportion of all traffic accidents are not reported or entered into the accident record system. These factors affect the reliability of aggregate accident statistics.

3 **Compilation of Accident Statistics.** The magnitude and general characteristics of traffic accidents may be determined by summaries compiled at local, state, and national levels. (See Secs. B and C.) These statistics have the greatest relevance to those in the traffic safety community whose efforts may affect safety on a broad scale. By contrast, highway and traffic engineers implement improvements on a limited portion of the roadway system; as a result, they require accident statistics for individual intersections or sections of road.

4 **Normalization of Accident Statistics.** Crash, injury, and fatality experience may be normalized by relating the frequency of these events to some measure of exposure; the most common accident rates are computed in relation to the amount of travel, the population, and the number of registered vehicles.

- a. *Accident rate per quantity of travel* is usually expressed in units of accidents per million vehicle-kilometers ( $\text{acc}/10^6 \text{ veh}\cdot\text{km}$ ); fatality rates are expressed as fatalities per 100 million vehicle-kilometers ( $\text{fatalities}/10^8 \text{ veh}\cdot\text{km}$ ). However, travel-based rates may not give an accurate or meaningful indicator of actual hazard.
- (1) Vehicle-kilometers can be estimated at the state level using records of fuel sales and assumptions regarding the average fuel consumption rates for all vehicles. However, travel data for specific areas, such as a city, or for specific situations, such as hour of the day or type of highway, are known only to the extent that reliable traffic counts are available (see Chap. 5). Supplementary traffic counts are typically required to determine accident rates for particular locations. The determination of travel-based accident rates for subsets of the traffic, such as older drivers or tractor-trailer combinations, require special studies to ascertain the amount of travel by these groups.
  - (2) The calculation of an accident rate for a specific collision type requires knowledge of the exposure to risk for the particular type of accident. For example, the exposure of pedestrians to risk of vehicle impact or the exposure of vehicles to impact by railroad trains is not adequately reflected by  $\text{veh}\cdot\text{km}$  figures.
  - (3) The accident rate for short sections of road or for low-volume roads can be quite erratic; under these conditions, even a single traffic accident can result in an exceptionally high rate (see Sec. E.2.b).
- b. *Accident rate per vehicle volume* is typically used in the analysis of intersections, where the rate is commonly expressed as accidents per million entering vehicles ( $\text{acc}/\text{mev}$ ).
- c. *Accident rate per population* derives from the medical profession, where infection and mortality rates for various diseases are often expressed in relation to population. In highway safety analyses, the rate may be stated in terms of total population, the number of licensed drivers, or a specific subset (e.g., teenage drivers). When making comparisons among different jurisdictions, however, population is not a good surrogate for exposure in highway safety, because vehicle travel per capita varies from one jurisdiction to another.
- d. *Accident rate per registered motor vehicle* seeks to normalize crash experience using the number of vehicles that could be involved. On a statewide basis, the count of registered vehicles is probably more reliable than the population count. In either case, however, an accident could involve a driver or a vehicle from another state.
- e. *Severity rates* attempt to describe the injury-causing potential of crashes.
- (1) The *fatality quotient* (ratio of fatalities to total accidents) must be used cautiously, because the level of reporting of "property damage only" (PDO) accidents varies among jurisdictions. The fatal/injury ratio (ratio of fatal to all injury-causing accidents) may be more reliable, because crashes resulting in injuries are more likely to be reported.
  - (2) The *severity index* (SI) was formerly used to describe the proportion ( $0 \leq \text{SI} \leq 1$ ) of all accidents that resulted in a fatality or an injury. More recently, the severity index has been redefined to express on a scale of 0 (PDO) to 10 (always fatal) the relative potential for a specified collision type to result in an injury. (See Ref. 1.)

## B. National Statistics (Ref. 2 for 2004 statistics, Ref. 3 for 2003 statistics)

- 1 **Fatalities** (Fig. 9-1). Following a low of 24,000 fatalities annually during the Second World War, annual highway fatalities in the United States rose almost continuously to a peak of 54,600 in 1972. The dramatic drop of 9,000 fatalities in 1974 was primarily attributable to the energy crisis, which resulted in the imposition of the 90 km/h national speed limit and reduced travel. Other factors, including improved vehicle safety features and the results of a continuing effort to remove physical hazards from the roadside also contributed to the reduction. Over the past two decades, annual fatalities have fluctuated between 39,200 and 47,100; there were 42,600 in 2004. The travel-based fatality rate has decreased steadily over the past 75 years; in 2004, it was 0.91 fatalities per  $10^8 \text{ veh}\cdot\text{km}$ .

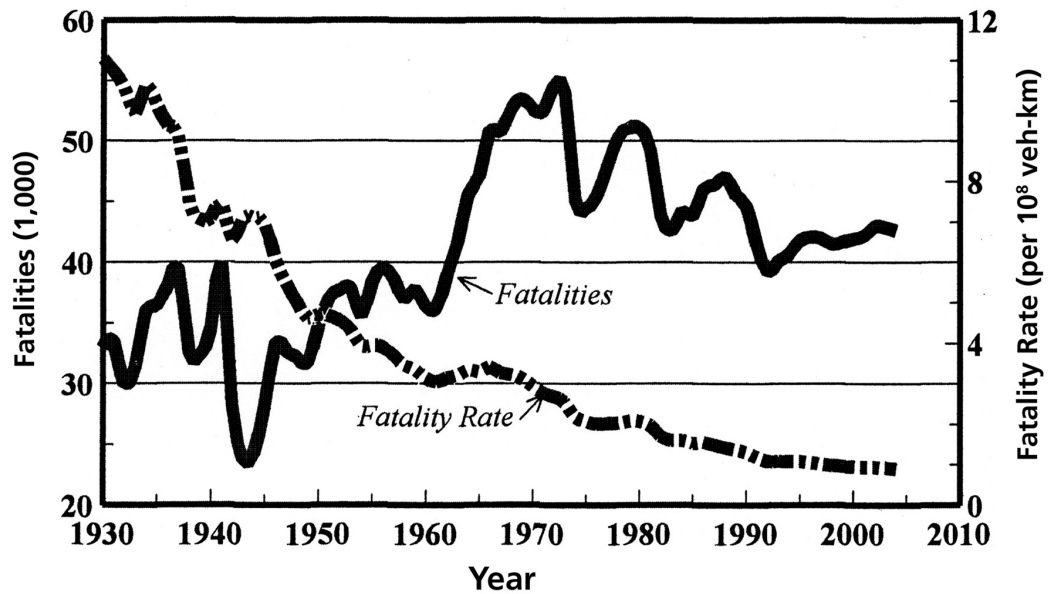

Fig. 9-1—U.S. Highway Fatalities and Fatality Rates, 1930-2004

- 2 **Collision Type.** In 2004, multivehicle collisions accounted for 18,900 fatalities, single vehicle crashes (principally fixed object and overturning crashes) resulted in 17,900 fatalities, and impacts with pedestrians and pedalcyclists resulted in 4,600 and 700 fatalities, respectively. The remaining fatalities occurred in collisions with railroad trains and animals.
- 3 **Total Accidents.** Because the definition of a reportable accident and the level of accident reporting vary among jurisdictions, the total number of traffic accidents in the U.S. is unknown. NHTSA estimates that 11.3 million drivers were involved in 6.2 million police-reported crashes in 2004.
- 4 **Characteristics of Fatal Accidents.** Since 1975, NHTSA has cooperated with states to obtain detailed information on every fatal highway crash. The resulting Fatal Analysis Reporting System (FARS) provides one indicator of highway safety in the U.S. NHTSA prepares annual reports (such as Ref. 2) from FARS and its National Accident Sampling System/General Estimates System (GES), which collects a nationally representative sample of police-reported crashes in all severity categories.
  - a. *Alcohol Involvement.* NHTSA defines a fatal crash as "alcohol-related" if either a driver or non-occupant (pedestrian or bicyclist) had a blood alcohol concentration (BAC) of at least 0.1 grams per liter (g/L). Approximately 40% of all fatal crashes (but only 7% of all crashes) were alcohol-related. Persons with a BAC eight times greater (0.8 g/L) are considered intoxicated in 45 states; 34% of the fatalities occurred in accidents where a driver or non-occupant was intoxicated. Nearly 70% of the 14,600 persons killed in these latter accidents were themselves intoxicated. Alcohol is more likely in collisions involving a single vehicle, on weekends, and at night. Alcohol involvement in fatal highway crashes has decreased by 14% over the past decade.
  - b. *Motorcycles.* These vehicles account for only 0.3% of all highway travel, 1% of reported crashes, and 2% of all registered vehicles, but 9% of all vehicle occupant fatalities. More than 4,000 motorcyclists were killed in traffic crashes in 2004, compared to 2,300 in 1994. Approximately 24% of the fatally injured motorcyclists were driving without a valid license, nearly 29% were intoxicated, and 43% were not wearing a helmet. Based on their amount of travel, motorcyclists are 27 times more likely than passenger car occupants to die in a motor vehicle crash.



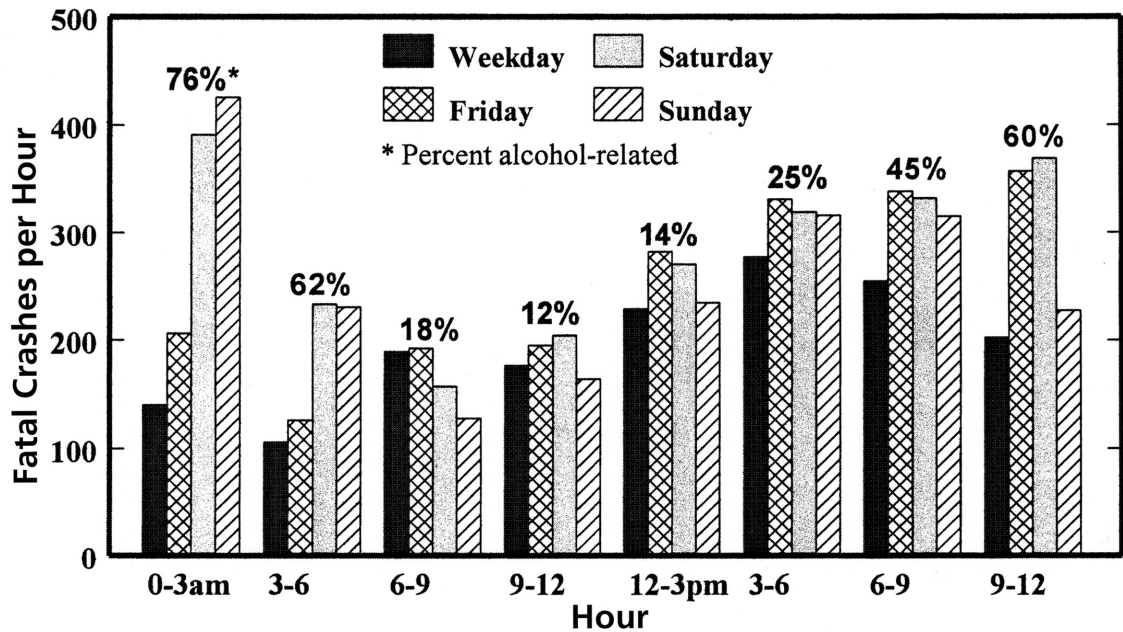

Fig. 9-2—Hourly Distribution of Fatal Crashes, U.S., 2004

c. *Temporal Distribution.* Nationwide in 2004, there were 228 fatal crashes on average for each hour of the week. Fig. 9-2 shows, however, that there are substantial differences between the hourly crash experience on weekdays (Monday through Thursday) and the weekend. The afternoon and evening hours on the weekend have above-average numbers of fatal accidents per hour, but the numbers for the early morning hours of Saturday and Sunday are even higher. Crashes where the driver was impaired by alcohol are more common during these hours as well.

d. *Younger and Older Drivers.* According to national statistics (Ref. 3), drivers in the age range 15-20 are significantly overrepresented in crashes. In fatal crashes, for example, these drivers have an involvement rate of 64 per 100,000 licensed drivers, while the rate for drivers aged 21 and over is 27.

Persons over the age of 69 constitute 9% of the U.S. population; over the past decade, this cadre has grown much faster than the total population. Older individuals hold 10% of all drivers' licenses, but account for 12% of traffic fatalities and 16% of pedestrian fatalities. Traffic fatalities involving older drivers occur primarily during the daytime (82%) and generally involve another vehicle (74%). The fatal crash involvement rate for older drivers is 23 per 100,000 licensed drivers.

e. *Other Fatal Crash Parameters, 2004.*

- (1) "No adverse atmospheric conditions" were reported for 82% of these fatal crashes; 8% occurred in rainy conditions and 2% in snow/sleet. The road surface condition was "dry" for 82% of the crashes.
- (2) The road geometry was characterized as "straight" at 74% of the sites and "level" at 71% of the sites.
- (3) The modal speed limit at the crash sites was 90 km/h (31%); the next most common speed limit was 70 km/h (14%). Speed limits of 95-105 km/h were at 13% of the sites and, somewhat surprisingly, speeds limits in excess of 105 km/h were found at only 7% of the sites.

f. *Creating a FARS query.* Ref. 2 provides an online tool for analysts to easily tabulate or cross-tabulate 160 crash, person, vehicle, and driver variables. These analyses, which can be done for single or multiple states, are limited to fatal crashes.

### C. State Accident Statistics

- 1 NHTSA maintains a voluntary State Data System (SDS) of accident records (Ref. 4). As of 2004, 29 states contributed police accident report data to this system. Because of variations among states in variables collected and formats, the records are converted into a standard format. The data base is comprehensive, but not representative of the nation as a whole. Nevertheless, it is used by the U.S. Department of Transportation to prepare special studies of crash characteristics.
- 2 NHTSA also maintains files of state traffic safety information, including fatality rates, crash characteristics such as alcohol involvement, restraint use, and speed, as well as the cost of traffic crashes and the amount of highway safety funds available to the state (Ref. 5).
- 3 In general, states do not allow direct access to their computerized accident records. However, they usually prepare annual reports that are often available online, such as:
  - a. California's *Statewide Integrated Traffic Records System* (SWITRS), maintained by the California Highway Patrol (CHP). All local agencies are required to send all injury accident reports that were field-investigated by an officer to the CHP, which compiles them into SWITRS. Quarterly and annual summary reports are returned to each local agency engineering department. Crash statistics include such items as a ten-year summary, time/date, drivers and vehicles, alcohol, trucks, location, and similar parameters (Ref. 6).
  - b. Washington State's Department of Transportation's *Annual Collision Data Summary*, which is also available online (Ref. 7), with parameters similar to those in California's system.
  - c. New Mexico's annual reports on traffic crash information (Ref. 8) that include statistics of interest to engineers, enforcement personnel, and human factors experts.

### D. Engineering's Relationship to Traffic Safety

Highway and traffic engineers have a very real responsibility to provide a safe roadway environment for the prudent road user. Acceptance of this responsibility has led to improved roadway design and traffic control and was partially responsible for the decreasing highway fatality rates (see Fig. 9-1) from 1930 through 1960. However, the engineering community has needed periodic reminders of its responsibility to aggressively promote highway safety.

- 1 As the number of highway fatalities increased dramatically in the 1960s, and as the decrease in the fatality rate leveled off, Congress enacted two important pieces of legislation: the Motor Vehicle Safety Act of 1966 (designed to improve the safety of vehicles) and the Highway Safety Act of 1966 (see Chap. 33). This latter legislation had several significant and immediate effects on the engineering aspects of traffic safety:
  - a. It mandated federal guidelines and financial support for traffic engineering services. Activities under this program have educated many engineers on the safety aspects of traffic engineering.
  - b. It required programs for the identification and surveillance of accident locations, with the objective of finding treatments to reduce the frequency or severity of crashes.
  - c. It created a National Highway Safety Bureau (now NHTSA) to focus on highway safety issues. The NHTSA safety matrix (Fig. 9-3) reminded highway engineers that there are safety-improvement opportunities in the pre-crash phase (accident prevention), in the crash phase (lessening damage from a collision), and in the post-crash phase (learning from the experience) to make the roadway safer, regardless of the faults of the driver and the vehicle.
- 2 Prior to 1970, many highway engineers felt that they were only responsible for designing the road; if a driver strayed onto the roadside and struck a fixed object, for example, that was the driver's fault, not the engineer's. In 1968, Congress chastised engineers for this attitude (Ref. 9):

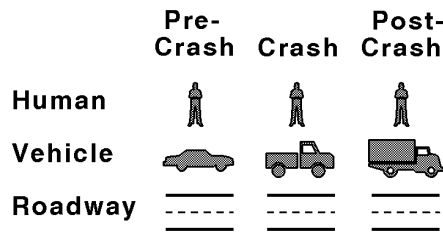

Fig. 9-3—Highway Safety Matrix

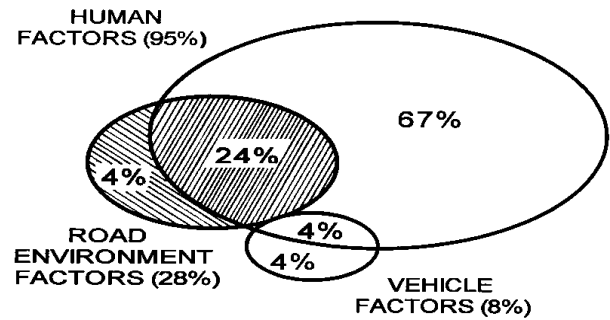

Fig. 9-4—Contribution Factors in Crashes (Ref. 12)

"It is the height of cynicism to contend that the drivers should never have left the road, or that many of them must have been drunk, or that somehow the driver was at fault. Why or how he left the road is not the issue. Whether he left because he was drunk, or stealing a kiss, or because he suffered a bee sting, dozed, had a blowout, was sideswiped, or was forced off is irrelevant to road builders. What is relevant is that those who are responsible for road construction recognize that the roadside is as vital to the safe operation of a vehicle as the pavement itself, and that the duty to make the roadside safe is a very real one."

- Subsequent federal legislation has required highway and traffic engineers to improve their tools for the detection of highway safety deficiencies, to implement cost-effective remedies, and to assess the effectiveness of alternate treatments.
- There is overwhelming evidence (Refs. 10-11) that both spot locations and extended sections of road can be made safer through the application of sound engineering practice. It follows, therefore, that the absence of good design and operations can contribute to crash occurrence. Nonetheless, human error is often cited as "causing" over 90% of all traffic accidents. If this misleading statistic is believed, it follows that there is no meaningful opportunity for engineering to contribute to improved safety. Fig. 9-4 depicts a more realistic role of contributing factors, showing overlap among the human, roadway, and vehicle factors that contribute to crashes. Most highway and traffic engineers have come to understand that properly designed and operated roads will accommodate some human mistakes, particularly in those areas where a combination of human and roadway factors contributed to the crash.

### E. Designing and Implementing a Highway Safety Improvement Program

Safety program guidelines initially mandated by the Highway Safety Act of 1966 required processes for studying safety problems, implementing solutions, and evaluating results with the objectives of:

- Identifying locations where accident loss experience is unusually high.
- Assigning priorities to appropriate measures to reduce accidents or their severity.
- Evaluating the effectiveness of accident reduction methods and programs.
- Providing continuing surveillance of the highway system and its accident experience.

The following steps are needed to achieve these objectives.

#### 1 Collect and Maintain Data.

- Define the Highway Location Reference System so that each crash can be uniquely located by route and milepost, geographic coordinates, or similar methods. The location system and the importance of its proper use must be explained to those who will collect crash data.

b. *Collect and Maintain Accident Data.*

- (1) *Legal Requirement.* Although individual state requirements differ, all traffic accidents involving fatalities, injuries, or damage to a vehicle to the extent that it cannot be driven from the scene under its own power should be reported.
- (2) *Completeness of Reporting.* For a variety of reasons, drivers involved in PDO or minor injury accidents may choose not to report them. Sources suggest that about half of the motor vehicle crashes throughout the country are not reported (Ref. 3).
- (3) *Accident Report Forms and Files.* Although there is no "standard" accident report form, data on the time, location, parties involved, and environmental factors are commonly collected. These may be supplemented by a sketch and narrative. Original accident reports are normally maintained for at least three years, and stored in a location file by route and milepost or by street and nearby intersection. New technology has lessened the burden of maintaining hard-copy reports while permitting the faster retrieval of accident data. Most states require local jurisdictions to submit accident reports or accident statistics to a state-level agency.
- (4) *Spot Maps.* Enforcement agencies may maintain spot maps, with color-coded pins (for crash severity) indicating accident locations. These maps are of little value to the engineer, however, because they provide no guidance in selecting the appropriate types of countermeasures. Computer-generated spot maps by manner of collision (e.g., a map of all angle collisions) can overcome this shortcoming.

**2 Identify Hazardous Locations.** Because accidents are rare and random, traffic safety analyses should be based on several years of data. Separate analyses are normally conducted for spot locations (e.g., intersections) and extended sections of road, for urban and rural roadways, or for other conditions that could lead to differing accident experience. The following techniques may be used:

- a. *Number of Accidents.* The simplest method for rating the safety of a group of similar locations (e.g., urban unsignalized intersections) is to determine which have the highest accident frequency. Some jurisdictions use this technique to prepare a list of the "Twenty Highest Accident Intersections." The failure to include some measure of exposure is the major shortcoming of this technique.
- b. *Accident Rates.* If reliable traffic volume data are available, accident rates provide a superior tool for identifying hazardous locations. On a section of road with length  $l$  (km) and average daily traffic (ADT) of  $v$  vehicles that experienced  $A$  accidents in a 3-year period, the accident rate  $R$  (per  $10^6$  veh•km) is given by:

$$R = \frac{A \bullet 1,000,000}{3 \bullet 365 \bullet l \bullet v} \quad [9.1]$$

At an intersection or similar spot location with a total entering volume of  $v_e$  vehicles per day, the accident rate  $R$  (per mev) is given by:

$$r = \frac{A \bullet 1,000,000}{3 \bullet 365 \bullet v_e} \quad [9.2]$$

An accident rate of, say,  $3.0/10^6$  veh•km has little meaning without comparison to the average accident rate at a set of sites with similar characteristics. If sites  $1, 2, \dots, n$ , with lengths  $l_1, l_2, \dots, l_n$  and ADTs  $v_1, v_2, \dots, v_n$  have  $A_1, A_2, \dots, A_n$  accidents during a 3-year period, the average accident rate is calculated as:

$$\bar{R} = \frac{1,000,000 \bullet \sum_{i=1}^n A_i}{3 \bullet 365 \bullet \sum_{i=1}^n (l_i \bullet v_i)} \quad [9.3]$$

The calculation of  $\bar{R}$  must include sites that had zero accidents. Calculated accident rates may give misleading results on sections with small amounts of travel. Unless all the sites had identical amounts of travel, the average calculated using Eq. 9.3 will not be the same as the average of the accident rates at the  $n$  individual sites. To identify sites for more detailed safety examination, the engineer would choose locations where the accident rates exceeded some threshold value, such as twice the average.

- c. *Number-Rate.* To help guard against the shortcomings of the methods described above, some agencies have established cutoff values for both the number of accidents (per km/yr or per intersection/yr) and the rate of accidents. To be considered for further study, a location must exceed both values.
- d. *Rate Adapted from Quality Control.* This methodology has been adapted from the quality control techniques used in industrial engineering. It defines as hazardous those sections or spots with observed accident rates higher than would be "expected" due to normal variation. Using the average accident rate for similar locations, a critical rate  $C_i$  is calculated for each location in the following manner:

$$C_i = \bar{R} + k \cdot \sqrt{\frac{\bar{R}}{m} + \frac{1}{2 \bullet m}} \tag{9.4}$$

where  $k$  establishes the level of statistical significance ( $k = 1.645$  for  $\alpha = 0.05$ ), and  $m$  is the travel on a particular section (expressed in millions of veh•km; if travel = 47,000,000 veh•km, then  $m = 47$ )

If the actual accident rate  $R_i$  for a section of road exceeds its calculated critical rate  $C_i$ , it is potentially a hazardous location and deserves further study.

Accident rates are easily determined for freeway segments between adjacent interchanges. Fig. 9-5 portrays one jurisdiction's average run-off-the-road accident rate (0.198 acc/10<sup>6</sup> veh•km) for rural Interstate highways, the actual rate for 24 rural segments, and the calculated critical rates for these segments. The figure demonstrates that longer segments with greater travel have lower critical rates. Six segments that deserve further attention are readily apparent in this figure.

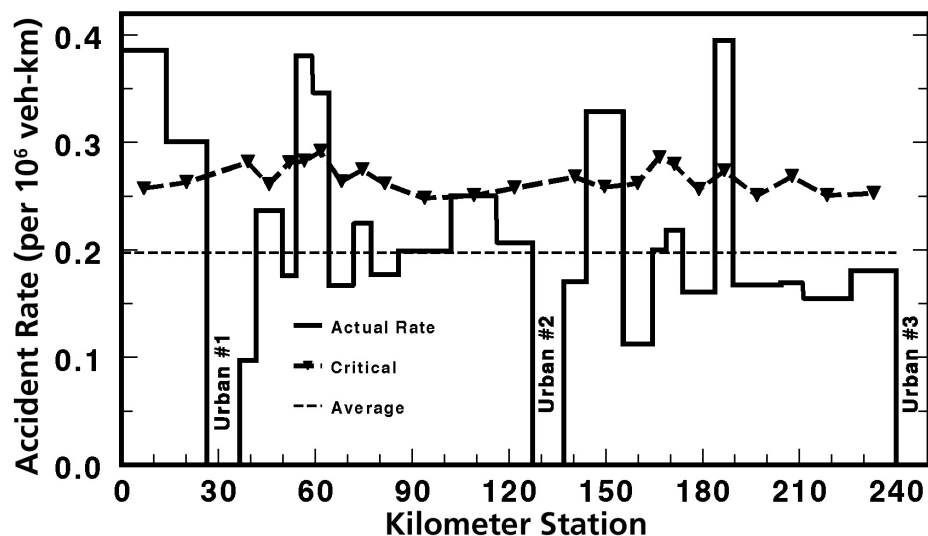

**Fig. 9-5—Interstate Run-Off-The-Road Accident Rates**

- e. *Verifying Hazardous Location Status.* If the foregoing techniques identify a hazardous location, the engineer should confirm the accuracy of the data. In particular:
  - (1) Ensure that accidents coded to a particular spot or section actually occurred there.
  - (2) Check the accuracy of any volume data used to calculate accident rates.

f. *Other Methods.* There are other techniques that do not rely on accident statistics for identifying potentially hazardous locations. They include:

- (1) *Hazard Indices.* When accident experience is relatively infrequent, as at rail-highway grade crossings, a hazard index based on parameters such as train volume, highway volume, and degree of crossing protection can be used to assess relative hazard (Ref. 13).
- (2) *Conflict Analysis.* A traffic conflict is essentially a near-miss; a location that has a substantial number of conflicts will probably have an accident problem. Tools have been developed (Ref. 14) to measure conflicts, although they are probably more useful for evaluating, rather than identifying, problem locations.
- (3) *Warrant Analysis.* Guidelines have been developed for the effective use of various highway and traffic features, such as positive guidance (Ref. 15). Sites that lack these features but meet the recommended criteria for their use could certainly be considered potential improvement locations.

**3 Identifying Accident Reduction Countermeasures.** Most, although probably not all, locations can be made safer through the application of highway and traffic engineering countermeasures. On the other hand, few if any engineering treatments can be guaranteed to eliminate all traffic accidents of a particular class. The goal of the engineer in traffic safety analyses is to identify the forms of corrective action that will be cost-effective in improving the safety at hazardous sites.

a. *Condition Diagram.* To plan a reasonable corrective strategy, the engineer must understand the physical conditions at the site. A scale drawing of the location (a condition diagram, Fig. 9-6) should be prepared for each suspected hazardous location. Total stations and CAD tools have dramatically simplified the preparation of these diagrams.

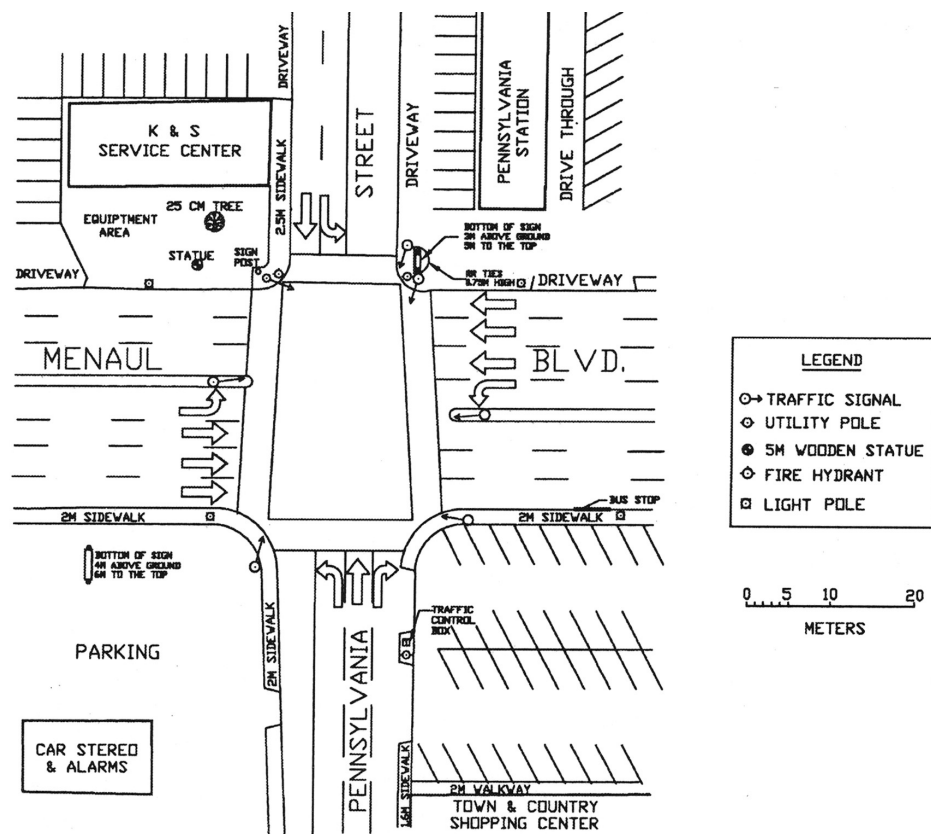

**Fig. 9-6—Condition Diagram**

b. *Collision Diagram.* Highway and traffic engineers introduce specific improvements on limited segments of the roadway system to reduce certain types of collisions. Therefore, to identify the most appropriate countermeasures, it is essential that the engineer review the types of crashes occurring at a particular location. The most effective tool for this purpose is a collision diagram, a schematic representation of the crashes at the location (see Fig. 9-7). While practices vary among agencies, the collision representation on the diagram may be supplemented by date, time, accident report number, and environmental conditions.

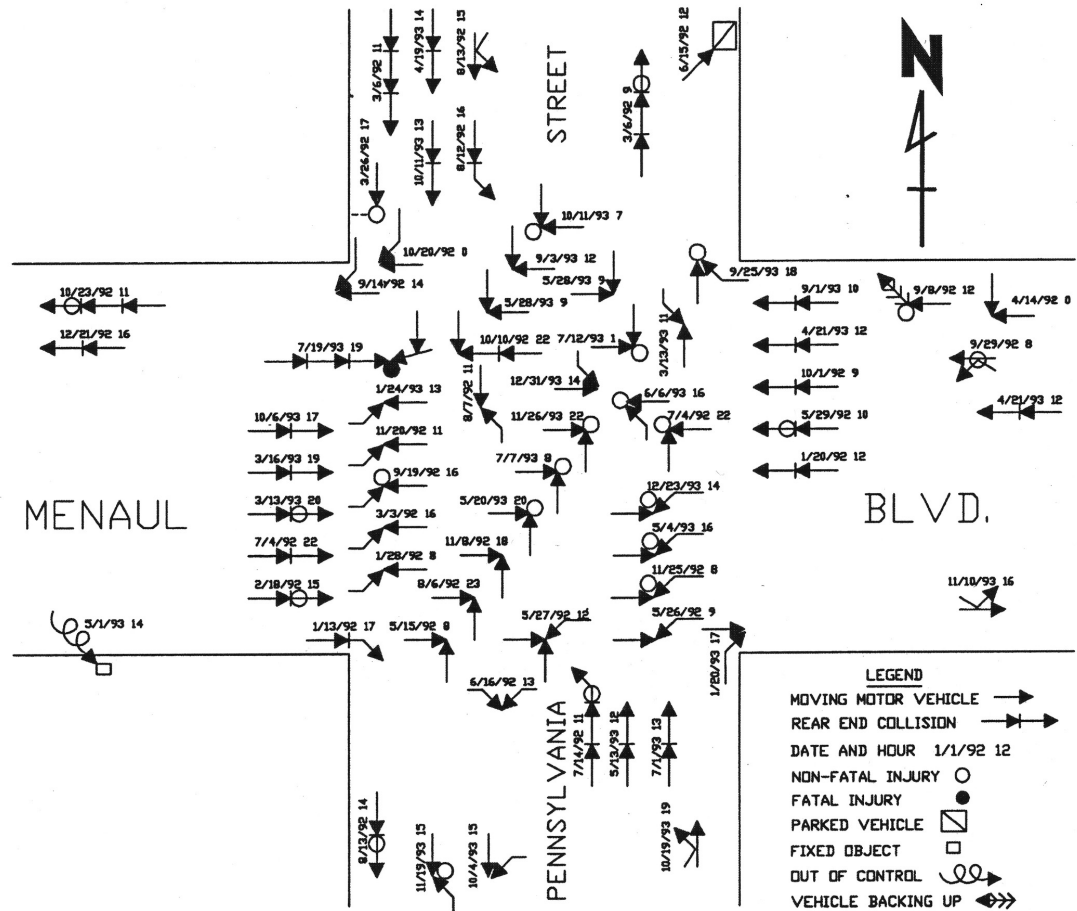

Fig. 9-7—Collision Diagram

- c. *Corrective Measures.* Numerous technical references suggest corrective actions for addressing certain accident patterns; some are intuitive (e.g., improve skid resistance for wet-weather accidents) while others are not (e.g., replacing 3 wide lanes with 4 narrow lanes to improve both capacity and safety). Chaps. 19-26 and 28 identify possible countermeasures. ITE's Traffic Safety Toolbox (Ref. 16) recommends potentially effective treatments for a wide variety of hazardous locations.
- d. *Countermeasure Effectiveness.* The engineer should estimate the effectiveness of potential countermeasures in reducing crash frequency or severity. FHWA has published aggregate statistics on the effectiveness of safety treatments (Ref. 17), but these results also suffer from methodological problems. Caltrans has evaluated many of its safety projects to determine what has been effective; a sample of their results is given in Table 9-1. In order to use this table for estimating accident reductions, a site must have experienced 4 or more accidents (nighttime accidents in the case of roadway lighting) during the past 3 years. Under no circumstances should the engineer assume that a treatment will eliminate all accidents.

Recent efforts (Refs. 18-19) have developed Accident Modification Factors to help estimate the benefits of safety treatments.

**Table 9-1—Accident Reduction Factors for Selected Highway Safety Projects**

Type of Project	Average Accident Reduction	Life (years)
Flashing beacons	20% of all accidents	10
New safety lighting	15% of night accidents	15
Curve correction	50% of all accidents	20
Rumble strips	50% of drift off road accidents	10
Superelevation correction	50% of run-off-road accidents	20/10†
Truck escape ramps	75% of run-away truck accidents	20
New left-turn channelization:		
Without left-turn phase	15% of all accidents	20/10†
With left-turn phase	35% of all accidents	20/10†
Non-signalized	35% of all accidents	20/10†
Two-way LT lane	25% of all accidents	20/10†

† 20 years with standard geometrics with widening; 10 years with substandard geometrics.

e. *Benefits and Costs.* Safety projects provide benefits to highway users by reducing the number and/or severity of accidents. Quantification of these benefits requires that costs be assigned to different levels of crash severity and used in conjunction with crash reduction estimates.

(1) Based on the procedures of a 1991 study (Ref. 20), FHWA recommends motor vehicle accident costs for use in highway safety analyses. The comprehensive costs are given in relation to crash severity on two scales: the abbreviated injury scale, where crashes are described in 6 categories, and the KABC scale, which uses 4 injury categories. FHWA's recommended costs per injury are given in Table 9-2.

**Table 9-2—FHWA Accident Costs per Injury (1994 dollars)**

KABC Scale			Abbreviated Injury Scale		
Severity	Descriptor	Cost	Severity	Descriptor	Cost
K	Fatal	2,600,000	AIS 6	Fatal	2,600,000
A	Incapacitating	180,000	AIS 5	Critical	1,980,000
B	Evident	36,000	AIS 4	Severe	490,000
C	Possible	19,000	AIS 3	Serious	150,000
PDO	Property Damage Only	2,000	AIS 2	Moderate	40,000
			AIS 1	Minor	5,000

(2) It is inappropriate to use past severity experience at a specific site, especially if it involved a fatality, to project future accident cost savings. The fact that there was a fatality at a hazardous location last year does not support a conclusion that a life will be saved during each coming year due to the installation of an engineering countermeasure. The most effective use of the cost data in Table 9-2 is to calculate for similar sites (e.g., rural intersections) an average loss ( $\bar{L}$ ) for each manner of collision, given by:

$$\bar{L} = \frac{\sum (l \cdot n(l))}{n} \tag{9.5}$$

where  $l$  = loss associated with a particular injury level (from Table 9-2)  
 $n(l)$  = number of level  $l$  injuries due to a certain manner of collision  
 $n$  = total number of accidents with the specified manner of collision



For example, a 5-year accident analysis for rural intersections on New Mexico state highways found that 458 opposite-direction left-turn accidents resulted in 15 fatalities, 176 incapacitating injuries, 139 evident injuries, 247 possible injuries, and 571 damaged vehicles (Ref. 21). Using this information and Eq. 9-5, the average loss from opposite-direction left-turn accidents at these intersections is \$178,000. This value is used in estimating the monetary benefits from any improvement that reduces opposite-direction left-turn collisions at rural intersections on the state's highways.

- 4 **Establish Project Priorities.** The supply of justifiable safety improvement projects invariably exceeds the improvement budget. The engineer's objective should be to maximize the total safety benefits within the constraints of available funds. Data in Ref. 17 suggest that an agency with a fixed budget will achieve greater safety benefits with numerous small, low-cost projects than with a limited number of major projects.
- 5 **Schedule and Implement Safety Improvement Projects.** Prepare plans and specifications for the improvement, and complete the project with agency personnel or contractors.
- 6 **Evaluate the Effect of Implemented Improvements.** The difficulties encountered in Sec. E.3.d. above can be significantly alleviated if agencies will conduct evaluations of their completed improvements. As described in Ref. 22, studies of treatment effectiveness must be carefully planned and implemented to ensure meaningful results. The traditional "before" and "after" study of accident experience, for example, has serious shortcomings that can lead to incorrect results. All analyses should be performed using rigorous statistical methods. Appendix A, as well as Refs. 23-25, provide guidance on the evaluation of safety improvement projects. The results of these studies, both positive and negative, should obviously be shared with the appropriate agency personnel; they should also be conveyed to the remainder of the highway and traffic engineering community through technical presentations and papers.

#### REFERENCES

1. Turner, D.T. and J.W. Hall. *Severity Indices for Roadside Features*. NCHRP Synthesis 202, Transportation Research Board. Washington, DC: 1994. 54 pp.
2. U.S. National Highway Traffic Safety Administration (NHTSA). Data for 2004 developed from the FARS data base, available at <http://www-fars.nhtsa.gov/>.
3. NHTSA. *Traffic Safety Facts 2003*. (Latest published data) Washington, DC. Available at <http://www.nhtsa.dot.gov/people/ncsa/>.
4. State Data System, National Center for Statistics and Analysis, NHTSA. Available at <http://www-nrd.nhtsa.gov/departments/nrd-30/ncsa/SDS.html>.
5. State Traffic Safety System, NHTSA. Available at <http://www.nhtsa.dot.gov/stsi/>.
6. Statewide Integrated Traffic Records System, California Highway Patrol. Available at <http://www.chp.ca/switrs/>.
7. Annual Collision Data Summary, Washington DOT. Available at <http://www.wsdot.wa.gov/mapsdata/tdo/accidentannual.htm>.
8. New Mexico Traffic Crash Information, Division of Government Research, University of New Mexico. Available at <http://www.unm.edu/~dgrint/annual.html>.
9. Blatnik, J.A. "The Need for Highway Safety Consciousness". *Roadside Hazards*. The Eno Foundation of Highway Traffic Control, Inc., 1968.
10. Transportation Research Board. *Relationship Between Safety and Key Highway Features*. State of the Art Report 6, Washington, DC: 1987. 110 pp.
11. U.S. Federal Highway Administration. *Safety Effectiveness of Highway Design Features. Vol. I, Access Control; Vol II Alignment; Vol. III, Cross Sections; Vol. IV, Interchanges; Vol. V, Intersections; Vol VI, Pedestrians and Bicycles*. FHWA-RD-91-44 through -49. Washington, DC: 1992.

12. Austroads. *Road Safety Audits*. Sydney, NSW, Australia: 1994.
13. U.S. Federal Highway Administration. *Railroad-Highway Grade Crossing Handbook*. FHWA-TS-86-215. Washington, DC: 1986.
14. Parker, M.R. and C.V. Zegeer. *Traffic Conflicts for Safety and Operations*. U.S. Federal Highway Administration, FHWA-IP-88-027. Washington, DC: 1989.
15. Lunenfeld, H. and G.J. Alexander. *A User's Guide to Positive Guidance*. U.S. Federal Highway Administration, FHWA-SA-90-017. Washington, DC: 1990. 95 pp.
16. Institute of Transportation Engineers. *The Traffic Safety Toolbox: A Primer on Traffic Safety*. Washington, DC: 1993. 255 pp.
17. U.S. Federal Highway Administration *The 1996 Annual Report on Highway Safety Improvement Programs*. Washington, DC: April 1996.
18. *Prediction of the Expected Safety Performance of Rural Two-Lane Highways*, FHWA-RD-99-207. Available at <http://www.tfhrc.gov/safety/pub/99207/>.
19. *Safety Analyst*. Available at <http://www.safetyanalyst.org/>.
20. The Urban Institute. *The Costs of Highway Crashes*. U.S. Federal Highway Administration, FHWA-RD-91-055. Washington, DC: 1991.
21. Hall, J. *Economic Benefit of Accident Reductions*. Compendium of Papers (CD-ROM), 68th Annual Meeting of the Institute of Transportation Engineers. Toronto, 1998.
22. U.S. Federal Highway Administration. *Accident Research Manual*. FHWA-RD-80-016. Washington, DC: February 1980.
23. Lovell, J. and E. Hauer. "New Directions for Learning About the Safety Effect of Measures." *Transportation Research Board Record 1068*. 1986. p. 96-102.
24. Ogden, K. *Safer Roads: A Guide to Road Safety Engineering*. Brookfield, VT: Avebury Technical. 1996.
25. Hauer, E. *Observational Before-After Studies in Road Safety*. Tarrytown, NY: Pergamon. 1997.



### A. Introduction

Motor vehicle users must store their vehicles for varying lengths of time at each end of every trip. The average passenger car is driven about 19,500 km per year. Assuming a conservative average speed of 40 km/h, the vehicle is in motion only about 500 h and at rest more than 8,000 h per year.

Vehicles parked on streets hamper the movement of traffic; this is critical where the street space is inadequate to accommodate both moving and parked vehicles (See Chap. 12). The need to regulate curb parking and supply off-street parking occurs in and around every high-traffic-density area, including central business districts (CBDs), shopping centers, cultural and educational facilities, medical centers, transportation terminals, and other major activity centers.

The availability of adequate parking can be a factor in trip generation and, hence, in the development and utilization of land. Zoning laws have historically required the provision of adequate parking as a condition for granting construction permits on the premise that all motor vehicle storage demand generated by a project must be accommodated. In an antithetical practice, some recent parking polices have included restrictions on the amount of parking to be furnished, with the intent of limiting land development, encouraging trip mode changes from automobile to transit, or both.

### B. Types of Data Related to Parking

- 1 **Parking Supply.** Number of available spaces, stratified by on-street and off-street, by free and fee, and by unlimited and time-limited.
- 2 **Parking Activity**
  - a. *Trip generation* - the number of arrivals (departures) per unit of time.
  - b. *Accumulation* - number of vehicles parked at any moment.
  - c. *Occupancy* - proportion of spaces utilized at any moment.
  - d. *Duration* - length of time parked by individual vehicles.
  - e. *Turnover* - average number of vehicles parked per space per study day.

Some of these factors can be calculated from others. For example:

  - Occupancy = Accumulation ÷ Total spaces
  - Turnover = Total cars parking (unparking) ÷ Total spaces
  - Mean duration = Mean accumulation ÷ Total cars parking (unparking)
- 3 **User Information.** Trip purpose, primary and secondary origins and destinations.

## C. Parking Studies

To address parking problems, studies must be conducted to collect information on the capacity and use of existing parking facilities, the location and extent of demand for parking, the adequacy of access and egress capacity at off-street facilities, the influence of these facilities on traffic flow in their vicinity, and the effect and desirability of modifying the parking supply or rate structure. Studies may be restricted to a particular traffic generator or a larger area, such as a business district (Ref. 1), a neighborhood (Ref. 2), or a major facility, such as a university (Ref. 3). A study may also examine parking management issues, such as parking meters, time limits, enforcement, and fines (Ref. 4). Some or all of the following studies may be included in a comprehensive parking evaluation (see also Ref. 5):

- 1 **Designation of Survey Area.** A cordon line (see Chap. 5) is drawn to delineate the study area. It should include both the traffic generators of concern and a periphery encompassing all points within an appropriate walking distance. The region should include the area of the current problem along with the vicinity that might be affected by ensuing parking changes. The boundary should minimize the number of entrance and exit points to facilitate cordon counts. Subsequent parking studies will normally require that the survey area be subdivided into small zones suitable for data collection and analysis.
- 2 **Inventory of Parking Facilities.** The following information regarding existing parking spaces at the curb and in off-street facilities should be collected:
  - a. Location and number of spaces that might be utilized, even temporarily.
    - (1) In curb parking inventories, include all truck and passenger loading zones, bus stops, hydrant zones, other no-parking zones, driveways, and similar "illegal" parking spaces.
    - (2) Metered, marked spaces at curbs are easy to identify in the field; some cities assign a street address to each meter and others use GPS. In the absence of pavement markings, assume that each 7 m of curb is sufficient to park one passenger vehicle.
    - (3) Portions of the parking supply may be reserved under provisions of the Americans with Disabilities Act (Ref. 6). Other off-street spaces may be reserved for employees, building visitors, or others; these spaces should be clearly identified in the inventory.
    - (4) The marked spaces in self-park lots and garages define the number of available spaces. In facilities where attendants park vehicles in the aisles, capacity could be up to 50% greater.
    - (5) If license plate surveys (see C.4.b. below) are planned, sketches of the parking zones and space numbering should be prepared; an example is shown in Fig. 10-1. The sketch will help avert data collection errors if multiple field observers are used, and will ensure consistency for subsequent parking studies in the same area.
  - b. Parking rates: meters, off-street facility charges, special rates for carpools.
  - c. Time limits and hours of applicability; hours of operation for off-street facilities.
  - d. Layout of spaces: parallel, angle, presence of other features (e.g., crosswalks, hydrants) that may affect space usage.
  - e. Ownership of off-street facilities.
  - f. Permanence: whether parking facilities are long-term or likely to be eliminated pending future development at the site.

To ensure that inventory data are current and accurate, they should be collected by field inspection throughout the study area. Records and aerial photography can be used to obtain some data and supplement others. Parking inventory information should be aggregated and summarized by zones (each block face or off-street facility).

- 3 **Accumulation Counts.** These are conducted to obtain data on the number of vehicles parked in a study area and to use as a check against other data.

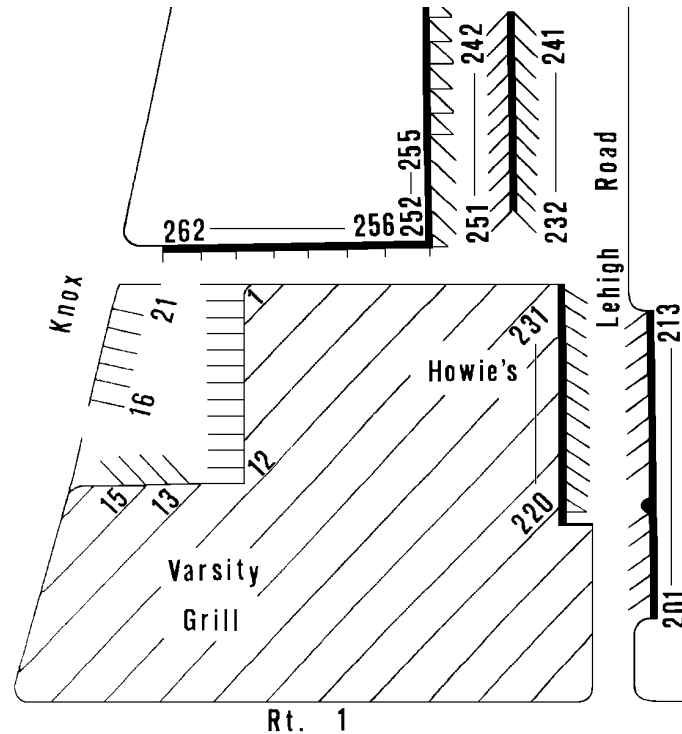

**Fig. 10-1- Sketch of Parking Space Layout and Numbering**

- a. After a cordon is drawn around the area, counts of entering and exiting vehicles are started early in the morning when it is possible to make a good estimate of the number of vehicles already within the area. During each subsequent time period, total vehicle accumulation inside the cordon equals the previous accumulation plus the number of entering vehicles minus the number of those leaving.
    - (1) To obtain parking accumulation, the number of circulating vehicles must be estimated and subtracted from the known number of vehicles within the cordon.
    - (2) A large number of circulating vehicles is one indicator of a parking problem. Likewise, parking accumulations approaching 95% of the legal spaces in the study area suggest a problem.
  - b. If only the maximum parking accumulation is needed, and if the approximate time when this occurs is known, a single observation of the survey area will suffice. In the case of large surface parking lots at shopping centers, stadiums, and other major traffic generators, parking accumulation at one point in time may be determined from an aerial photograph. Since illegal parking spaces are not readily apparent in these photographs, counts of parked vehicles by aisle should be compared with the corresponding inventory data or sketch.
  - c. Accumulation data are normally summarized by time period for the entire study area and possibly for critical zones. Fig. 10-2 in Sec. E shows the occupancy (accumulation/total spaces) for central business districts in small and large urban areas.
- 4 Duration and Turnover Surveys.** The accumulation study does not provide information on parking duration, turnover, or parking violations; this information, which is usually necessary in a parking study, requires the use of a license plate survey.
- a. *Continuous observation.* At entrances and exits to off-street parking facilities with few access points, observers record the license plate number and observation time for arriving and departing vehicles. At busy facilities, a sample of vehicles (e.g., only even-numbered licenses) should be sufficient. Field observations are merged to find the arrival and departure times of each vehicle. The information can be used to calculate individual and mean durations, the distribution of durations (number parked for < 1 h, 1-2 h, etc.), turnover, accumulation, occupancy, and total trips generated.

- b. *Patrolling at regular intervals.* In studies of curbside parking, license plates are surveyed at regular intervals by circulating foot patrols (occasionally by motorized vehicle). Using special data collection forms with provision for each parking space identified in C.2.a, the observer codes the vehicles in these spaces as "new" (not seen on the previous circuit) or "repeat" (seen on the previous circuit). Special notations should be used for trucks (if they are not identifiable from their license plate number), expired meters, double parking, and vehicles without license plates. Accumulation and occupancy are readily computed from the field data. The number of trips generated, the turnover rate, and the distribution of parking durations can also be estimated. It is important to note, however, that some vehicles parking for short periods may arrive and depart between the patrols, and thus will not be observed. For this reason, the results will be biased toward longer parking durations, lower accumulation and turnover, and too few trips generated. Vehicles observed during either the first or last patrol also pose a problem for duration calculations, because either their arrival or departure time is unknown.

For the reasons cited above, selection of the license plate survey length and the time interval between successive patrols is crucial; shorter study periods and longer patrol intervals will reduce data collection and analysis costs at the expense of study accuracy. The following situations arise:

- (1) In the absence of a maximum time limit (e.g., regional shopping centers), one can assume that the parking duration distribution is a negative exponential. For this case, Daganzo (Ref. 7) has developed formulae to determine the optimum interval between patrols, given a first estimate of the mean parking duration (based on prior experience) and the length of the study. The method also provides the most likely estimate of the actual mean parking duration, the variance of this value, the distribution of durations, and the total number of cars involved. Patrol intervals are usually at least as long as the expected mean parking duration, resulting in a study of fairly low personnel needs and costs.
- (2) If there is a maximum parking time limit (e.g., curbside parking in business districts), the distribution of parking durations assumes a truncated form for which mathematical relationships have not yet been developed. To include most vehicles parking for brief durations, the patrol intervals must be fairly short. Ref. 5 suggests intervals of 5 minutes for zones governed by a 15-minute time limit, 20–30 minutes for 1-hour zones, and 30–60 minutes for 2-hour zones; however, no basis for these intervals is given. Since time restrictions along a single block face may vary, the shortest time limits within a data collector's route should govern. Field data may be corrected by selecting a small typical zone for continuous observation, plotting its parking duration, and then using this adjustment curve to correct the data for the total survey area.

In planning license plate studies, assume that each patrolling observer can check about four spaces per minute; the exact value will vary with the parking duration (observers work faster when there are more "repeat" vehicles whose license numbers do not have to be written down again). The first patrol is slower than the subsequent ones, since the license numbers for all vehicles must be recorded. The situation can be mitigated by starting the survey at a time when relatively few vehicles are parked.

A portion of a typical field data collection form is shown in Table 10-1. Note that it is not necessary to record the entire license plate number. The ✓ indicates repeat vehicles, the E suffix indicates an expired meter, and the T prefix identifies a truck. Hand-held keyboards and related software can be used in major studies to increase the rate of data collection and to simplify processing and analysis.

- 5 **User Information Surveys.** Individual parkers can provide valuable information that is not obtainable with license plate surveys. The two principal methods for acquiring these data are:
  - a. *Parking Interviews.* A randomly chosen sample of parkers is interviewed to obtain the following data:

- (1) Destination (including any secondary destinations).
- (2) Origin of trip (nearest major intersection, not street address).
- (3) Purpose of trip (work, shop, personal business, etc.).
- (4) Frequency of making this trip (daily, weekly, monthly).

Interviews are conducted either as drivers leave their vehicles (easier to identify sample, but response will be about planned activity and parkers may be in a hurry) or as they return (may miss seeing some returning drivers, but response will report actual destinations). Interviewers also record the parking space location, the number of vehicle occupants, and the time of arrival and departure. Generally one interviewer is required for each 15 short-time spaces.

**Table 10-1– Typical License Plate Survey Field Form**

Street	<u>Knox Road</u>	Side	<u>South</u>	Study Date	<u>0/28/05</u>		
From	<u>Rossbourg Dr</u>	To	<u>Route 1</u>	Dir. of Travel	<u>SB</u>	Data Collector	<u>Bernie</u>

Space No.	Space Desc.	Time at the beginning of the patrol									
		9:00	9:30	10:00	10:30	11:00	11:30	12:00	12:30	1:00	1:30
81	Bus Z										
82	Bus Z			T151		336					
83	Meter	423	✓	✓	✓	621E	416	✓		006	✓
84	Meter	534		214		161		511	✓	306	912
85	Meter		909		243	✓	✓E		296	✓	
86	Meter		762	179	✓	✓		319	✓	615	✓
87	Fire H					815		T061			
88	Tr LZ	T503		T480		658		T691	✓		

b. *Postcard Study.* Postage-paid postcard questionnaires requesting the information cited above are placed under windshield wipers of parked vehicles. Parkers are requested to complete and return the survey. While return rates can reach 35%, the results may be biased because the return rate can be expected to vary with the parker's level of education or other social characteristics. To avoid irritating potential respondents, the local enforcement agency should be asked to forego issuing parking citations while the survey is being conducted.

- 6 **Land Use Method of Appraising Parking Demand.** Utilizing the following steps, it is possible to use parking generation rates (see Ref. 8) to estimate the demand for parking:
  - a. Tabulate the type and intensity of land uses throughout the study area.
  - b. Based on reported parking generation rates, estimate the amount of parking space needed per unit land use.
  - c. If necessary, determine worker demand for parking from questionnaires to employees.
- 7 **Legal, Administrative, and Financial Studies.** These are necessary in developing plans for whatever additional off-street facilities are being considered. (See Ref. 9.)
- 8 **Analysis of Data.** Parking data are analyzed and summarized by zones; data from geographically proximate zones should be combined if they exhibit similar parking characteristics. The analyses should:
  - a. Determine the parking demand along with the final destination of parkers. It is common to find excess demand in certain zones while the overall study area has a parking surplus.
  - b. Identify the degree of meter violations and illegal space use; excessive unlawful parking may suggest the need for more enforcement, change in time limits, or revised parking fees or fines.



- c. Assess the extent of underutilized spaces near the study area periphery; these may be made more attractive to long duration parkers by extending the time limits or lowering the rates.
- d. Evaluate turnover by zone; these rates may be increased, where necessary, with shorter time limits.

### D. Peak Period Parking Demand

Ref. 8 presents data on peak period parking demand—maximum accumulation of parked cars—as a function of land use. Table 10-2 lists some typical values. The engineer should note the very wide range of values; also, sample sizes for many of the land use categories in Ref. 8 are very small. Mean peak demand should therefore be viewed cautiously. The variations among nominally identical land uses are attributable to the exact location of each facility, the quality of transit service, the amount and cost of available parking, and other more subtle factors.

It is therefore incumbent on parking planners to obtain additional data directly from the site being studied (or if it has not yet been developed, from a similar site) and to use Ref. 8 only for a first estimate or for comparison. In most instances, a cordon count or direct count of parked vehicles at the time when maximum parking demand is expected will be required.

**Table 10-2—Peak Period Parking Demand Related to Selected Land Uses**

Land Use	Sample Size	Peak Parking Demand (veh/unit of Land Use)†		
		Mean	Range	Units*
Multifamily residential				
Low and medium rise	14	1.3	0.7 - 2.1	DU
High rise (central city)	7	1.5	1.2 - 1.6	DU
Hospital, urban	23	3.7	1.5 - 7.4	Bed
Medical clinic	6	4.8	4.0 - 5.4	100 m <sup>2</sup> GFA
Assisted living	11	0.25‡	0.15 - 0.35‡	DU
General office building	173	3.1	0.9 - 6.0	100 m <sup>2</sup> GFA
Drive-in bank	49	3.0	0.6 - 8.0	100 m <sup>2</sup> GFA
Shopping center - weekday	78	4.0	1.6 - 7.9	100 m <sup>2</sup> GLA
Shopping center - Saturday	82	5.1‡	2.2 - 8.1‡	100 m <sup>2</sup> GLA
Home improvement superstore	34	3.4‡	2.1 - 4.6‡	100 m <sup>2</sup> GLA
Quality restaurant	12	16.6	7.5 - 31.9	100 m <sup>2</sup> GLA
HTSD <sup>§</sup> restaurant, urban	10	6.0	3.4 - 13.4	100 m <sup>2</sup> GLA
HTSD <sup>§</sup> restaurant, suburban	13	14.3	4.5 - 26.2	100 m <sup>2</sup> GLA
Church	11	0.15◊	0.03 - 0.25◊	Seat

Source: Calculated from Ref. 8.

† - Data collected weekdays except ‡ - Data collected Saturdays; ◊ - Data collected Sundays.

\* - DU - Dwelling unit; GFA - Gross floor area; GLA - Gross lease area. § - High-turnover, sit-down.

### E. Parking Characteristics in Central Business Districts

In 1968, FHWA undertook a survey to assess the parking characteristics in urban areas. In cooperation with the Transportation Research Board, this effort utilized data from 111 parking studies performed in U.S. cities between 1960 and 1968. Although these data (Ref. 10) are now 40 years old, they remain the most comprehensive evaluation of urban parking characteristics. More recent information is unfortunately scant, although Ref. 8 presents parking data from a limited number of studies in the 1970s and 1980s. ITE has increased its involvement in parking issues (Ref. 11). Even though the numerical results from the FHWA survey would undoubtedly be different today due to changes in vehicle ownership, travel patterns, and the nature of CBDs, the general variation of parking characteristics as a function of urbanized area population, as summarized in the following sections, probably remains valid.

**1 Inventory of Existing Spaces.** Urban areas with small populations (10,000–25,000) had 150 CBD parking spaces per 1,000 population; approximately 40% were at the curb with the remainder in off-street lots. By contrast, the largest urban areas (over 1 million) reported 20 parking spaces per 1,000 population, with 55% in lots, 32% in garages, and only 13% at the curb. The trends of decreasing spaces per capita and more off-street parking were evident for intermediate population groups.

The FHWA survey found that, regardless of population, 45–55% of the CBD curb space was metered. As urban area population increased, the proportion of the curb space devoted to special uses (e.g., truck zones, bus zones) also increased. While most off-street spaces in smaller urban areas were privately owned, the majority of both lot- and garage-spaces in urban areas over 100,000 population were publicly owned.

**2 Facility Use.** For all population categories, parking spaces at the curb were primarily used by short term parkers; indeed, when x% of the spaces were at the curb, approximately 2x% of the parkers utilized these spaces. The reverse situation was true for lots and garages, which catered to the long-term parkers; although they provided 75–85% of the parking supply in larger urban areas, their share of the actual number of parkers was 15–20% less. These characteristics were also reflected by the CBD parking turnover for an 8-hour study period. For all curb spaces, the turnover decreased from nearly 7 in the smallest urban areas to 4 in the largest areas; the values were 30–40% higher at metered spaces along the curb. Over this same population range, the turnover in off-street facilities decreased from 1.8 to 1.1. In general, turnover was higher in lots than in garages.

**3 Occupancy and Accumulation.** Fig. 10-2 shows the average parking space occupancy in the CBDs of small and large urban areas between 10 am and 6 pm. In the smallest communities, the demand rarely approached the supply. In the CBDs of the higher population cities, whose area averaged 450 ha, the core area would be expected to have an even higher occupancy than shown in Fig. 10-2. The average occupancy for the entire CBD never reaches 100%, however, because spaces near the fringe of the CBD are beyond acceptable walking distances.

**4 Trip Purposes.** The primary trip purposes associated with parking in the CBD were shopping, personal business, and work. In the smallest urban areas, shopping accounted for nearly 40% of the trips, with personal business, work, and "other" each accounting for approximately 20% of the parking demand. With an increase in population, the share of the parking attributable to shopping decreased substantially. In the largest urban areas, work predominated (40%); personal business increased to 30% of the parking demand, but shopping dropped to 10%.

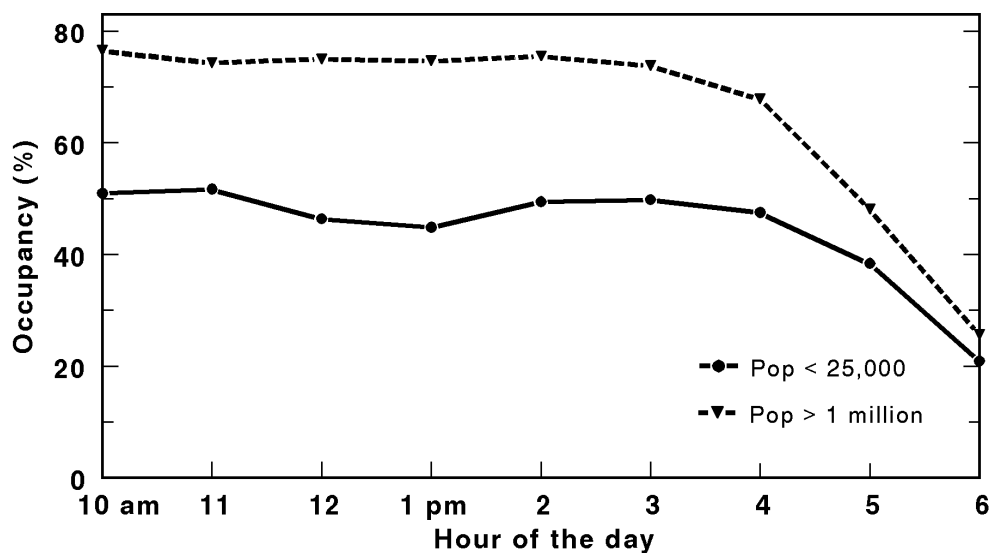

Fig 10-2- CBD Parking Occupancy versus Time of Day

- 5 **Parking Duration.** The average length of time parked ranged from 1.3 h in the smallest cities to 3.0 h in the largest. Trips for the purposes of shopping and personal business were approximately one-third these averages; parking for work trips, however, ranged from 3.5 h in the small urban areas to nearly 6.0 h in the larger urban areas. Although 60% of the CBD parkers in urban areas of <100,000 remained for less than 0.5 h, the median parking duration in the largest urban areas was 2.0 h.
- 6 **Walking Distances.** Average distances walked by parkers to their destinations increased from 60 m in the smallest urban areas to 170 m in the largest urban areas. This pattern existed for all trip purposes, but workers in all cities were willing to walk longer distances than shoppers and persons on personal business. At all population levels, motorists parking for greater durations were willing to accept longer walking distances. Individuals parking more than 5 h, for example, walked distances 60% greater than the average.

#### REFERENCES

1. "Downtown Kirkland Parking Study and Plan," 2003. Available at [http://www.ci.kirkland.wa.us/depart/planning/pdfs/CBD/Cok\\_parking\\_study/10\\_21\\_03updates/executivesummary.pdf](http://www.ci.kirkland.wa.us/depart/planning/pdfs/CBD/Cok_parking_study/10_21_03updates/executivesummary.pdf).
2. "Comprehensive Neighborhood Parking Study," 1999. Available at <http://www.ci.seattle.wa.us/transportation/parking/parkingstudy.htm>.
3. "Minnesota State University Parking Study," 2000. Available at [http://www.mnsu.edu/masterplan/plans/on\\_line\\_concerns/parking\\_study.html](http://www.mnsu.edu/masterplan/plans/on_line_concerns/parking_study.html).
4. "Parking Management Study," 2002. Available at <http://www.ci.seattle.wa.us/transportation/parking/parkingmanagement.htm>.
5. King, L. E. "Parking Studies," In: *Manual of Transportation Engineering Studies*. Englewood Cliffs, NJ: Prentice-Hall, 1994. Chap. 10.
6. "ADA Business BRIEF: Restriping Parking Lots." Available at <http://www.usdoj.gov/crt/ada/restribr.pdf>.
7. Daganzo, C. F. "Parking Studies, Gap Acceptance, and the Intervening Opportunity Model." *Proceedings, 8th International Symposium on Transportation and Traffic Theory*. Toronto, Canada: 1981.
8. Institute of Transportation Engineers. *Parking Generation, 3rd Edition*. Washington, DC: 2004.
9. Weant, R. A. and H. S. Levinson. *Parking*. Westport, CT: Eno Foundation for Transportation. 1990. 335 p.
10. Highway Research Board. *Parking Principles*. Special Report 125. Washington, DC: 1971. 217 p.
11. Swanson, H.A., and K.L. Swanson. "Increasing ITE's Involvement in Parking." *ITE Journal*, v. 70 n. 2, Feb. 2000.

### A. Purpose and Scale

The purpose of transportation demand studies (TDS) is to collect and analyze data pertaining to present and future transportation needs. These studies are an essential part of the transportation planning process (see Chap. 12). When first introduced during the 1950s and 60s, the emphasis of TDS was to support long-term regional land use and infrastructure planning, focused mostly on freeway and regional rail system developments. During the 1970s and 80s, with declining enthusiasm for major infrastructure programs, TDS focused on supporting local traffic and transit service improvement decisions. After the Intermodal Surface Transportation Efficiency Act of 1991 (ISTEA) and the Clean Air Act Amendments of 1990 (CAAA), emphasis shifted to needs such as congestion mitigation and air quality improvement (Refs. 1 and 2). Most recently, years of effort to refine and validate models and advances in information technologies have expanded the role of TDS to a wide range of infrastructure investment and service planning applications. The recent FHWA TRANSIMS project (Ref. 3) exemplifies the potential of emerging new capabilities for TDS which may ultimately prove as far-reaching as did the emergence of the Urban Transportation Planning System (UTPS) four decades ago.

TDS are conducted at several different scales. The amount of detail in the methodologies used depends on the scale as well as the time horizon and budget. Data from one scale of TDS can often be used at other scales. Ref. 4 covers these different kinds of studies in detail.

- 1 States or Groups of States.** A classic example is the Northeast Corridor Project, which covered the U.S. East Coast between Boston and Washington and encompassed transportation by private vehicles, bus, rail, air, and several alternative futuristic technologies (Ref. 5). More typically, these studies focus on particular modes such as air service or the potential for high-speed rail (Ref. 6). The geographic scale requires coarse-grained analysis; for example, using cities and counties as the geographic units of concern.
- 2 Metropolitan Areas.** The objective of metropolitan scale studies is usually to update plans of Metropolitan Planning Organizations (MPO) for improving transportation infrastructure with regional significance. At this scale, analysis is more detailed (e.g., based on census tracts). Facilities for mainly local circulation are not usually detailed. Some transportation modes, such as air and long-distance rail, may not be considered at all. Ref. 7 and Chap. 12 cover these studies in detail.
- 3 Subareas Within a Metropolitan Area.** Studies for individual jurisdictions and service districts develop local plans within the framework of the metropolitan plan. Smaller analysis zones are used, and greater amounts of detail are included (e.g., based on block groups within census tracts). Congestion management plans (Refs. 8 and 9) and studies of particular corridors and transit agencies (Ref. 10) exemplify this scale.

- 4 **Non-Metropolitan Areas.** Transportation decisions outside metropolitan areas may also require systematic analysis of the type described in this chapter. Examples include TDS for major rural recreation sites and transit needs studies for low-density rural areas.
- 5 **Site Impact Studies.** TDS are often done to address specific local issues, such as the impacts on the transportation system of a proposed development project or rezoning. Such studies may be done as part of an environmental impact study (see Chap. 29). Where trips to and from a study area are mostly within the geographic scope of an up-to-date larger scale TDS, it may be relatively easy to perform the analysis by systematic disaggregation of analysis zones within the larger scale TDS. See Ref. 11 for details.

## B. Overview of the TDS Process

Data collection is a very important element in TDS and can be very time consuming and costly. Therefore, where possible, historical data should be used. Existing data should be evaluated to determine if they are still usable or need to be updated, wholly or selectively. Data availability and collection methods are changing due to rapid advances in computing, sensing, and communications technologies. In particular, refinements in urban Geographic Information Systems (GIS), Global Positioning Systems (GPS), and electronic toll collection technologies offer significantly improved efficiency and accuracy in representing current travel conditions (Refs. 12 and 13). A strong trend exists toward enhancing established software packages for TDS with advanced GIS capabilities (see Sec. E).

Fig. 11-1 shows an overall schematic of the TDS process, details of which are discussed below. Although the figure implies a linear sequence, in practice, the activities shown in Fig. 11-1 are usually done simultaneously and iteratively. For example, some data collection typically occurs throughout the process. Indeed it is best to defer some data collection until study needs are fully clarified. See Chap. 12 for more details.

### 1 **Data Inventories** (Top section of Fig. 11-1).

#### a. *Land Use and Social Data.*

- (1) Inventory of types and intensities of land use (Sec. C below).
- (2) Information describing resident population, including household size and composition, income, vehicle availability, type of work performed by employed persons, etc. These data are obtained from the federal census (Ref. 14 and 15) and local supplemental surveys.

#### b. *Travel Patterns and Traffic Inventories.*

- (1) Travel survey data (see Sec. D below).
- (2) Traffic counts, including cordon and screenline counts (see D.2.c, D.8, and D.10.c below), on roadways and transit (see Chap. 5).
- (3) Parking patterns (see Chap. 10).

#### c. *Network Characteristics.*

- (1) Coverage and characteristics of the pertinent roadway network(s), including link lengths, free flow and congested speeds, capacities, turning restrictions, and other traffic control features.
- (2) Coverage and characteristics of the pertinent transit network(s), including speeds, vehicle capacities, route patterns, transfers, access, and service frequencies.
- (3) Locations, called "centroid connectors," where traffic generated in "analysis zones" is represented as entering and leaving the actual transportation network (see D.2.d below).

### 2 **Analysis of Present System** (Second section of Fig. 11-1).

- a. Processing of inventory data to understand the performance of the present system and the current travel patterns (squares in second section of Fig. 11-1).

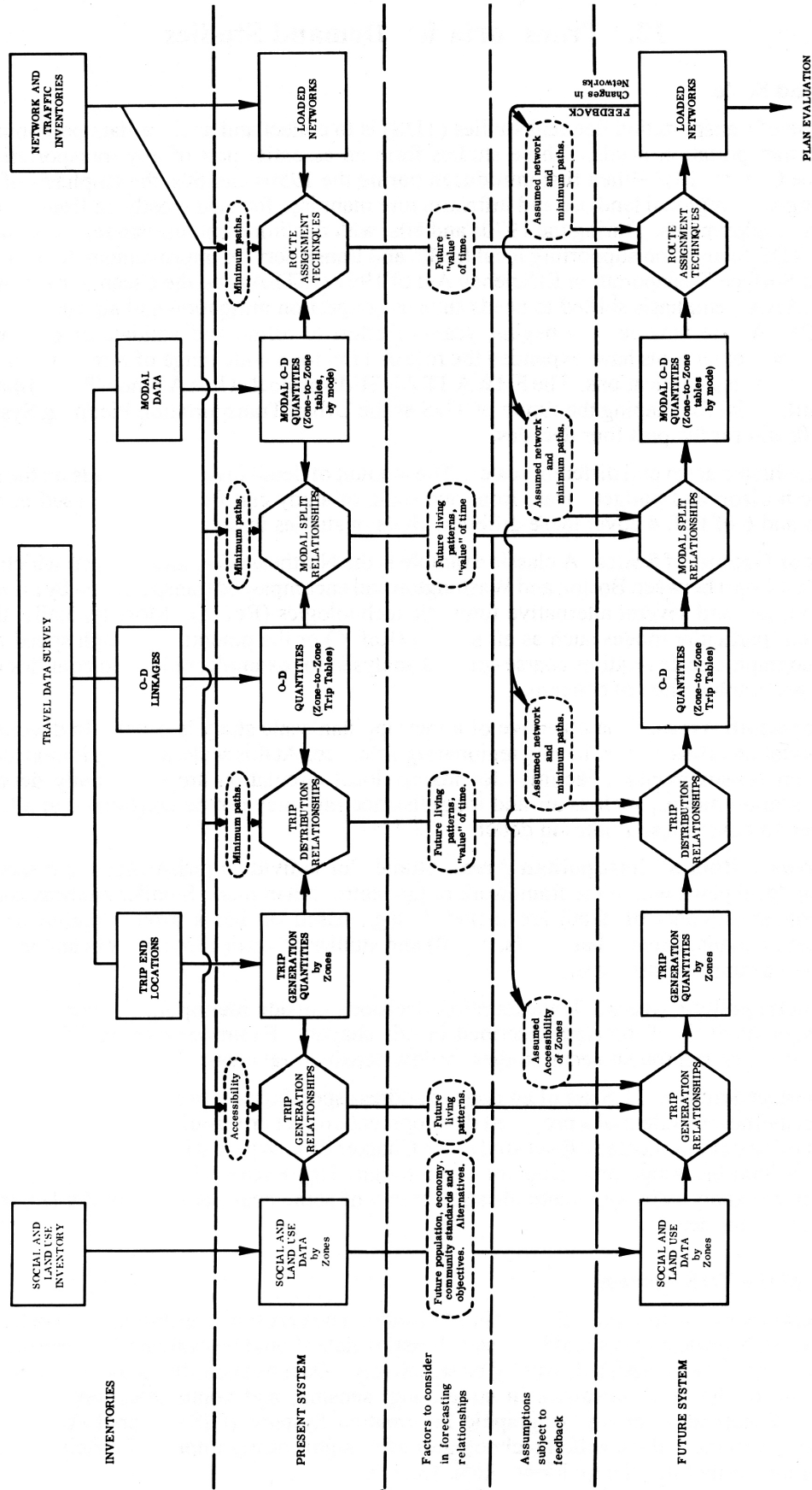

Fig. 11-1-Traffic Estimation Process

- b. Formulation of theories and mathematical models that fit present travel patterns. These are needed to make estimates of future demand (hexagons in the second section of Fig. 11-1). Note that Fig. 11-1 depicts only one of many possible approaches to this analysis. Modal split relationships, for example, may be performed either as part of trip generation, or after trip distribution (see Sec. H.1.c below).

### 3 Estimation of Future Travel Demand (Lower three sections of Fig. 11-1).

- a. Consideration of factors extraneous to the developed travel models. For example, in a long-range study, the models may be modified through professional judgment to reflect assumed changes in community values regarding travel, results of transportation marketing and pricing, new technologies, and significant shifts in work and consumption patterns. In addition, impacts of changes in household composition and the labor market, population age trends, and attitudes toward walking and bicycling in light of changing land uses must be considered.
- b. Preliminary design of future year networks to represent planning alternatives.
- c. Adoption of one or more scenarios regarding land use and demographic data for the planning year.
- d. Prediction of future travel on each alternative network generated by each land use-demographic scenario, using the models developed from behavioral theory and present travel patterns.
- e. Improvement of alternative network designs in view of the first attempts to load predicted future travel demands on them ("feedback").
- f. Evaluation of loaded networks for success in meeting criteria of efficiency, economy, safety, community acceptability, etc. (See Chap. 12.)

## C. Demographic and Land Use Inventories and Forecasts

- 1 **Census Data.** Working closely with state and local transportation planning authorities, the U.S. Census Bureau provides key data products that directly and indirectly support the needs of TDS.
  - a. Census geographic divisions (census tracts, block groups) serve as the building blocks for developing most systems of Traffic Analysis Zones (TAZ) (D.2.d. below).
  - b. TIGER line and boundary files, with digitized topography for every street and community in the country, provide the basis for many GIS and navigable transportation network data sets (see Ref. 15).
  - c. The Census Transportation Planning Package (CTPP 2000) customized to the needs of individual MPOs provides decennial household census data and journey-to-work travel data coded to regional TAZ geography (see Ref. 14).
  - d. *American FactFinder* and *State & County QuickFacts* provide easy on-line access to household data and maps of census geography, suitable for many TDS and transit planning applications (see Ref. 15).
- 2 **Land Use Data.** If not already available, land use and infrastructure data must be obtained in the field. Aerial photography can be useful but on-the-ground surveys must also usually be used. Many jurisdictions now keep much of these data in GIS (Ref. 12).
  - a. Land use data include type and intensity. *The Standard Land Use Coding Manual* (Ref. 16) provides a system of coding these data.
  - b. Information for land parcels is associated with TAZs (D.2.d. below).
  - c. If household surveys or activity center surveys are to be performed, land use inventories should be timed to be useful in selecting interview subjects (D.3.b. below).
- 3 **The Basis of Traffic Forecasts:**
  - a. Urban general plans, regional and metropolitan planning criteria, community values, information on effectiveness of past land use policies and zoning, etc.

- b. Population and economic models. The U.S. Census Bureau and state government agencies provide long-range population forecasts. California population forecasts are available through the Demographic Research Unit of the Department of Finance and the State Data Center (Ref. 17). Regional forecasts of employment and other economic indicators are far more difficult and, when available, are generally short-term. Universities and commercial research groups, including some major banks, conduct such forecasts.
- c. Transportation/land use models, which forecast based on linkages between accessibility and patterns of urban development. Although many different transportation/land use models exist, the DRAM-EMPAL (Putman) and MEPLAN Models appear to be the most commonly used. (Ref. 18)

## D. Travel Surveys

Refs. 19 and 20 provide detailed guides for the collection of travel data. Although urban-oriented, some methods, such as vehicle intercept/external surveys and site visitor surveys, are suitable for rural conditions. Ref. 21 deals directly with demand in rural settings, with emphasis on public transit planning needs.

- 1 **Overview. Travel tends to be repetitive.** Travel surveys, often called origin destination surveys, are designed to identify these repetitive patterns. Data are obtained for a sample of travelers selected to be representative of all relevant travelers. Collection of demographic/economic data and data on travel constraints are included in the travel survey procedure. The principal steps of the survey procedure are:
  - a. Survey planning.
  - b. Survey design.
  - c. Field implementation, which includes staffing, training, budgeting, scheduling, contingency planning, pilot testing, notifying proper authorities, data collection, and quality control.
  - d. Data preparation, including coding, data entry, validation, data cleaning, and formatting for analysis.
  - e. Data analysis.
- 2 **Survey Planning, Study Area Boundaries and Traffic Analysis Zones.** Identifies information requirements for the issues to be addressed in the study and the modeling to be performed. The survey population is defined; the study area boundaries and traffic analysis zones are specified.
  - a. The *survey population* contains the people whose travel is of interest. The appropriate survey population may be everyone living in a particular geographic area. However, the survey population may also be defined based on a combination of demographics, location, and revealed travel behavior, such as persons who commute in peak periods in a given travel corridor or to a particular part of town.
  - b. Survey planning requires a clear understanding of the *study area*, which is the geographic region for which travel demand relationships will be developed and applied. The study area contains the majority of trip origins and destinations of interest.
  - c. An external *cordon line* is established around the study area. Other internal cordons may also be established to surround areas of special interest, such as the city center. Cordon lines should follow political boundaries and minimize the number of points where transportation facilities cross. *External stations* are located on the external cordon where outside traffic enters, leaves, or passes through the study area. Since external stations are also trip origin and destination locations, their role is similar to TAZs, except that data acquisition and trip modeling are conducted separately.
  - d. The study area is divided into *TAZs* for modeling and other analyses. TAZs should be small where detailed traffic estimates on nearby transportation facilities are needed and large elsewhere. Where detail is needed, each TAZ should be as homogenous as possible in land use and of a size that peak hour trips to and from each TAZ are small compared



to the capacities of nearby transportation facilities. Census tracts and census block groups generally make good building blocks for TAZs. TAZ boundaries should follow natural barriers, like water bodies and steep terrain. Putting TAZ boundaries along major transportation facilities biases model results and should be avoided except where transportation facilities, like freeways and rail lines, are also barriers. Large TAZs reduce analysis costs but reduce accuracy. In some cases, TAZs are grouped into districts and super-districts to simplify data presentation and analysis.

- 3 **Survey Design.** Establishes the details of meeting the study's information requirements:
  - a. Determine applicability of previously existing data, including previous travel surveys and census products, such as the Census Transportation Planning Package (CTPP) (see Refs. 14 and 19, Appendix B).
  - b. Identify the *sampling frame*, which is the data set used to identify members of a survey population, from which the survey sample will be drawn.
  - c. Establish the sampling procedure(s) (D.4. below).
  - d. Determine the sample size (D.5. below).
  - e. Design the questionnaire and any script to be used in contacting respondents. The questionnaire typically features a *trip report* describing each trip made by household members in terms of origin and destination, start time and end time, purpose (activity type) at origin and destination, and travel mode. Other details are obtained about transit trips and parking, land uses at origin and destination, and vehicle availability for each trip. Questionnaires typically also elicit household *dwelling unit data* including location and structure type, household composition, total available vehicles, family income, and occupations of employed persons. Other data may include *public opinion* questions and *administrative and quality control data* about the interview, its coding, editing, etc. Some typical questionnaires are illustrated in Ref. 22.
  - f. Establish the field implementation plan.
  - g. Ref. 19 (Sec. 4.3) identifies some critical quality control issues:
    - (1) Is the population definition correct? Are most relevant persons included and most irrelevant persons eliminated?
    - (2) Does the sampling frame adequately represent the population? Are population members included only once, and are non-population members mostly excluded?
    - (3) Does the sampling procedure adequately cover the population and sub-populations of interest? Is the sampling method economical, unbiased, and can the data be expanded to represent the population characteristics of interest?
    - (4) Are response rates acceptable and unbiased? Can respondents easily do what's asked of them? Are questions understandable, non-leading, non-inflammatory, and unambiguous?
- 4 **Sampling Procedures.** Sampling procedures depend on the nature of the survey population, the expected use of the data, and the budget. Procedures are characterized by where and how respondents are contacted.
  - a. Sampling may be done at one or more of the following locations:
    - (1) Travelers' homes.
    - (2) Travelers' workplaces.
    - (3) Other activity centers (such as shopping and recreational areas).
    - (4) While traveling (on-board transit surveys, vehicle intercept surveys, parking surveys).
  - b. Different methods for contacting respondents are listed below in order of decreasing cost, accuracy, and lack of bias:
    - (1) Face-to-face interviews.
    - (2) Telephone interviews.
    - (3) Hand-out/mail-back self-administered questionnaires.
    - (4) Mail-out/mail-back self-administered questionnaires.
    - (5) Voluntary pick-up and drop-off questionnaires, usually at major activity centers.

- c. Occasionally, the target survey population is small and readily accessible, so data are obtained for the entire population. However, economy usually requires statistical sampling:
- (1) *Random sampling*: respondents are selected at random from the sample frame.
  - (2) *Systematic sampling*: respondents are selected from the sample frame following some pattern, such as first picking a respondent randomly and then contacting every  $n^{\text{th}}$  person after that. If the sampling frame is random, this is the same as random sampling and may be easier.
  - (3) *Stratified sampling*: the population is divided into subgroups (strata) and respondents are sampled from each to meet the sample size criterion. Stratification avoids over-sampling and under-sampling when there are different size subgroups but equally strong statistical inferences are needed for each. For example, stratifying by vehicle ownership will provide enough hard-to-find zero-vehicle households so that equally strong statistical inferences can be made for each vehicle ownership category. A difficulty with stratified sampling is acquiring the data to establish the stratified sample frame.
  - (4) *Cluster sampling*: the population is organized into clusters and a sample is obtained from the set of clusters. For example, in an employee travel survey, each business could be a cluster and a sample of businesses drawn from the set of all businesses in the study area. Then, either all employees or a second-level sample of employees would be identified at the chosen businesses.
  - (5) *Choice-based sampling*: analogous to stratified sampling except that the strata are defined based on revealed travel choices rather than previously known characteristics of the population. For example, a survey could seek a target number of respondents for each choice of travel mode.
  - (6) *Longitudinal sampling*: surveys in which data are obtained repeatedly over time to measure trends and changes. Respondents contacted at different times may or may not be the same individuals. Surveys that contact the same persons multiple times are called panels or panels with replacement.

5 **Sample Size.** Effective sampling obtains representative data from enough respondents so findings have acceptable accuracy and statistical confidence. In an ideal world, target accuracy and confidence levels for critical data would determine sample size. In practice, sample size usually is a compromise between acceptable statistical properties and acceptable cost.

- a. For a simple random sample from a large population, the sample size is based on the probability distribution of a representative data item regarded as a random variable. The relationship is:

$$n = \frac{\sigma^2 z^2}{D^2} \quad [11.1]$$

where  $n$  = the needed sample size (number of observations of the data item).

$\sigma$  = the standard deviation of the data item in the survey population.

$z$  = the two-tailed cutoff of the standard Normal distribution for the desired confidence level (for example,  $z=1.96$  for a typical 95% confidence level).

$D$  = the maximum acceptable error when the data item is estimated by averaging the observations in the sample.

For example, to determine the sample size to estimate with 95% confidence the average income of a population  $\pm \$1000$ , we set  $D=\$1000$  and  $z=1.96$ . Assume we somehow know that the standard deviation of income ( $\sigma$ ) is  $\$20,000$ . The needed sample size is then  $n=1537$ .

- b. The sample sizes for a travel survey is determined by adopting the largest  $n$  calculated for several key variables, for example, the number of trips per day or the fraction of trips by a particular mode. It is assumed that these are random variables following certain probability distributions which permit *a priori* estimation of the population standard deviation ( $\sigma$ ):
- (1) The number of trips per day can be assumed to follow the Poisson distribution, in which case:

$$\sigma = \sqrt{\mu} \quad [11.2]$$

where  $\mu$  = the trip rate we need to estimate.

It is much easier to make an informed *a priori* guess about  $\mu$  than about  $\sigma$  directly.

For example, the sample size needed to estimate with 95% confidence the number of daily work trips  $\pm 0.1$ , assuming *a priori*  $\mu = 2$ , with  $\sigma = 1.414$ ,  $D = 0.1$ ,  $z = 1.96$ , is  $n = 768$  respondents.

- (2) Proportions are assumed to follow the Binomial distribution, in which case:

$$\sigma = \sqrt{p(1-p)} \quad [11.3]$$

where  $p$  = the proportion we need to estimate.

For example, the sample size needed to estimate with 95% confidence the proportion of work trips using transit  $\pm 0.02$ , assuming  $p \leq 0.2$ , with  $\sigma \leq 0.4$ ,  $D = .02$ ,  $z = 1.96$ , is  $n = 1537$  trips (1537 respondents, if there is one independent choice per person.) Note: if  $p$  cannot be limited *a priori*, the worst case value  $p = 0.5$  is used.

- c. If the sample size  $n$  is large compared to the the survey population size ( $N$ ), the adjusted sample size is:

$$n' = \frac{n}{1 + \frac{n}{N}} \quad [11.4]$$

After collecting the data, statistical significance levels are determined from the actual data, not the *a priori* assumptions used for determining sample size (see Appendix A).

- 6 **Dwelling Unit Surveys.** This approach traditionally employs face-to-face interviews conducted at home, although telephone interviews have proven fairly successful at lower cost. Telephone surveys, like the 1991 Transportation Tomorrow Survey in the greater Toronto area (Ref. 23), use *Computer-Assisted Telephone Interviewing* (CATI) systems. The systems schedule calls, and interviewers enter responses directly into the computer. Complex question sequencing which varies with responses given can be easily implemented.
- a. *Sample selection of dwellings* is from lists prepared using assessment rolls, census tract data (C.1.d. above), phone directories, and/or field investigation. In the case of telephone contact, typically 90-95% of U. S. households have phones but 20-60% are unlisted, with most unlisted phones (50-60%) in California cities and Las Vegas. Random Digit Dialing (RDD) overcomes the problem of unlisted phones, but cooperation is low since it is not possible to give subjects advance notification and justification for the contact.
- b. *Interviews.* Trained personnel contact the interviewees preferably following advance notification. If no one is home, the interviewer typically tries at least two more times. The best time for home interviews is in the early evening. No substitutions of the selected households are permitted because, to expand the sample correctly, the proportion of dwellings vacant (unoccupied, or occupants away) must be known.
- 7 **Commercial Vehicle Surveys.** Data on truck and taxi movements are obtained by sampling vehicles at the locations where they are garaged.
- a. *Sampling.* Vehicles are grouped into classes for which separate analysis is desired; e.g., large trucks, small trucks. For each class, a separate sample is obtained. Cluster sampling is a convenient approach to this type of survey.

- b. *Trip report.* For each vehicle, all trips for one day are reported, typically giving origins and destinations, start and end times, numbers of passengers (for taxis), or load and commodity types (for trucks) and sometimes routes. GPS technology can facilitate this type of data collection.

A 1995 study (Ref. 24) gives an overview of some truck surveys in U. S. metropolitan areas.

**8 Vehicle Intercept Surveys.** Data are obtained on trips entering and leaving the study area or passing designated internal screenline locations. Cordon surveys obtain data on external trips having both origin and destination outside the study area (also called through trips) and external-internal trips with one end outside and the other inside the study area. Screenline surveys obtain data on both external and internal-internal trips, often for model validation and adjustment purposes. Intercept questionnaires generally limit the trip report to just the particular trip being observed, with trip route details often included.

- a. *Survey stations* are located where highways cross cordon lines or screenlines, intercepting a sample of traffic passing the site. Safety is a major consideration in locating and operating the stations. The schedule and procedure are designed to intercept the survey population of interest.
- b. *Traffic counts* are needed in order to expand the representative sample to the entire population. Classification counts are used to ensure representativeness and for expansion purposes.
- c. Depending on traffic volumes, physical site constraints, and available budget, either roadside face-to-face interviews, roadside distribution of hand-out/mail-back questionnaires, or a license plate survey may be used. In each case, proper organization and supervision of fieldwork will determine the quality of the results.
- d. *License plate surveys* may be conducted at high traffic locations where stopping motorists is impractical. License plates are matched by the DMV to names and addresses for subsequent contact. Videotape data acquisition and license plate recognition technologies may be used, supplemented by manual observations during poor lighting conditions. Disadvantages of license plate surveys are the time lag between observation and the actual travel data collection, as well as the difficulty of tracking down drivers in the case of leased and fleet vehicles.

**9 Onboard Surveys.** Onboard surveys are used to obtain an accurate picture of the transit-using population. This method can also be used to supplement multimodal travel surveys. Surveyors ride selected transit runs and, depending on conditions, either conduct face-to-face interviews, or distribute hand-out/pick-up, or hand-out/mail-back questionnaires. Cluster sampling is a convenient approach to this type of survey. On-board questionnaires generally limit the trip report to just the particular trip being observed, including details about routing, transit station/bus stop access, and transfers.

#### **10 Special Surveys.**

- a. *Parking Surveys:* See Chap. 10.
- b. *Special Traffic Generators:* These include travel surveys at airports, shopping centers, recreation areas, and other locations for which detailed travel data are needed. Methods may include vehicle intercept surveys, interviews of users and workers at the site, and hand-out/mail-back surveys.

#### **11 Data Analysis.**

- a. Data are coded and entered into computer files. Checks for missing and erroneous items are made.
- b. Data are expanded from the sample to represent the total population and eliminate any sampling biases.
- c. Origin-Destination (O-D) tables are usually prepared showing the numbers of trips by type between all pairs of zones. Screenline highway and transit counts are used to test the

extent to which the number of crossings based on survey data match the number observed in the field. Survey expansion factors are then adjusted to reconcile any differences. Comparisons almost always show field counts to be higher than the initial expanded survey trip counts because of the tendency to underreport actual trips.

- d. Various cross-tabs are prepared, which are needed in the calibration of the trip forecasting models.

## E. Formulation of Trip Forecasting Models and Future Trip Estimation

Before future trips can be estimated, it is necessary to develop mathematical models which capture the important regularities observed in present travel behavior. Trip data, demographic data, and land use data are the usual basis for preparing these models. Recent research further ties trip making to individuals' daily activity patterns, which may also be related to each person's household structure and lifestyle (see Ref. 25).

Once models have been satisfactorily formulated, they can be applied for trip estimation purposes to future land use, economic, and population scenarios and different transportation alternatives.

The following *four-step trip estimation process* is generally applied:

- 1 **Trip generation:** the quantity of trip ends at a TAZ or parcel of land.
- 2 **Trip distribution:** the pattern of trip interchanges among zones in the region.
- 3 **Modal split (mode choice):** the distribution of trips among available modes for person-trips.
- 4 **Traffic assignment:** the choice among available routes between origins and destinations and the consequent accumulated traffic.

Additional information, such as the time of day of travel and vehicle ownership (see Ref. 26) can be included; however, these factors are often merely set according to past observations.

Further discussion of the four-step process can be found in Refs. 27, 28, and 29. Although quick response manual methods are available (see Ref. 30), computers are usually extensively used. Government and consultants have developed a number of computer software packages including EMME/2, MICROTRIPS, MINUTP, QRS, System II, TMODEL2, TRANPLAN, TRANSCAD, VIPER/TP+ and others. (See Table 6-3 of Ref. 22, and Ref. 31.) There is greater integration of four-step models with GIS, as seen in TRANSCAD, CUBE, and TRANSIMS. The U.S. DOT supports the Travel Model Improvement Program (TMIP), a continuing effort to improve methods and user understanding (see Ref. 32).

## F. Trip Generation

The number of trips generated at each household and activity site varies with demographic, geographic, and land use factors. The relationships are complex and they may never be fully understood. However, enough similarities exist from location to location that the ITE national compilation of trip generation rates is regarded as an appropriate starting point for many analyses (Ref. 33). However, national average trip rates may differ significantly from rates developed from local factors. Transferred rates must be carefully validated and, if necessary, adjusted to local conditions. Refs. 34 and 35 provide guidance for making such adjustments.

- 1 **Data Sources.** Sources include trip data, demographic, and land use characteristics at each trip end. Results are usually expressed in person-trips for a time period, like the average weekday, and sometimes for particular travel modes. In order to make most effective use of household census data, a distinction is often made between trips produced and trips attracted at a zone:
  - a. *Trip productions:* the number of trips that begin or end at a household in the zone (*homebased trips*), and trips with neither end at home which begin in the zone (*non-homebased trips*).

- b. *Trip attractions*: the number of homebased trips that have the non-home end in the zone, and non-homebased trips that end in the zone.

The advantage of this approach is that homebased trips, which are the majority of trips, can be modeled as round-trips, from and to home. This provides stronger behavioral linkages between homebased trip productions and household characteristics. The main disadvantage is that the directionality is lost, so half the daily homebased trips must eventually be adjusted so they are not shown as traveling backwards. Since the behavioral linkages for predicting trip attractions and non-homebased trips are weaker, estimated homebased attractions are usually factored to sum to the total estimated number of homebased productions. The alternative to the production/attraction approach is to generate all trip ends together, and then apply *inbound/outbound* split factors.

- 2 **Analysis.** Usually based on trip rates, sometimes supplemented by multiple regression techniques. Separate relationships may be used for the peak period and the 24-hour day, and for different trip purposes. Trip rates give the average number of trips per unit measure of each type of generator, for example, trips per household, per employee, or per 1,000 sq. ft. of floor space. Different rates apply to different generator types. For example, the rate for households with two vehicles is higher than for those with one vehicle, rates for fast food restaurants would be different than for mortuaries, etc. Estimates for each TAZ are made by multiplying these trip rates by each zone's predicted amounts of generators for each planning scenario:

$$T_i = \sum_k R_k X_{ik} \tag{11.5}$$

where:  $T_i$  = the total trips generated at TAZ  $i$  in the planning year.

$T_k$  = the trip rate for generator type  $k$  (trips per time period per unit of generator).

$X_{ik}$  = the amount of generator type  $k$  predicted for zone  $i$  in the planning year.

- 3 **Stratification.** In developing trip generation relationships, the various types of generators are categorized so that the variation in trip making observed within each category is minimized. For example, the variation measured by the standard deviation of trips per day may be minimized if trip rates are developed for households stratified by the number of vehicles owned. Stratifying factors which have been used include:

- a. Household type (in residential areas) and employment type (in commercial and industrial areas).
- b. Private vehicle ownership or availability.
- c. Income.
- d. Proximity to the CBD, residential density, or both.

Ref. 36 contains a useful literature review of past trip generation analyses.

- 4 **Prediction.** After trip generation models are developed, judgment must be used to apply them to the future planning scenarios. Even though estimates of future population, income, etc. may be available, underlying changes in living and working patterns, leisure activity, communications and transportation technologies, and values may affect trip making in ways not captured in past trip generation relationships.

## G. Trip Distribution

- 1 **General Form.** All methods for estimating the interchanges of trips between zone pairs can be generically represented as follows:

$$T_{ij} = ZT_i T_j P_{ij} \tag{11.6}$$

where:  $T_{ij}$  = the estimated future trips from zone  $i$  to zone  $j$  (or produced in  $i$  and attracted to  $j$ ).

$T_i$  = the future trips originating (produced) at zone  $i$ .

$T_j$  = the future trips ending (attracted) at zone  $j$ .

$P_{ij}$  = the probability that a trip originating at zone  $i$  will end at zone  $j$ .

$Z$  = a scaling factor that constrains  $\sum T_{ij}$  to match the target trip generation value(s).

This generic model embodies two fundamental concepts:

- a. The trip interchange between any two zones is a function of the trip generation at those zones.
- b. The trip interchange probability is related to the difficulty of travel between the zones and/or to previously observed interchanges between them.

2 **Specific Methods.** The two most often used trip distribution models are distinguished by how they account for the influence of spatial interaction.

- a. *Growth Factor Methods.* These use existing trip interchanges as the measure of spatial interaction. Many different growth factor methods exist, including one developed by Furness:

$$T_{ij} = t_{ij} F_i F_j \tag{11.7}$$

where  $t_{ij}$  is the original number of trips from zone  $i$  to zone  $j$  and  $F_i$  and  $F_j$  are growth factors. The method uses iteration to factor the original trips  $t_{ij}$  until check sums  $\sum T_{ij}$  and  $\sum T_j$  for the factored trips converge to within a small percentage of the predicted trip generation values  $T_i$  and  $T_j$ . Each iteration follows these steps:

(1) Apply Eq. [11.7] with factors calculated as follows:

$$F_i = \frac{T_i}{\sum_j t_{ij}} \text{ and } F_j = 1.0 \tag{11.8}$$

(2) Set  $t_{ij} = T_{ij}$  for all  $i,j$  and again apply Eq. [11.7] with factors calculated as:

$$F_i = 1.0 \text{ and } F_j = \frac{T_j}{\sum_i t_{ij}} \tag{11.9}$$

(3) Check for convergence. If check sums (described above) do not match the target trip generation closely enough, set  $t_{ij} = T_{ij}$  for all  $i,j$  and perform another iteration.

Growth factor methods do not always converge and future trips are never allocated to any interchange where initially  $t_{ij} = 0$ . However, these methods work well if growth is modest, and land use is static.

- b. *Gravity Method.* This uses an inverse relationship with travel time or cost, called *friction*, as the measure of spatial interaction. A typical *doubly constrained gravity model* has the form:

$$T_{ij} = A_i T_i B_j T_j f_{ij} \tag{11.10}$$

where:

$$A_i = \frac{1}{\sum_j (B_j T_j f_{ij})} \tag{11.11}$$

$$B_j = \frac{1}{\sum_i (A_i T_i f_{ij})} \tag{11.12}$$

and  $f_{ij}$  represents the friction for travel from zone  $i$  to zone  $j$ , either a constant or a function of time or cost. Gravity models vary widely in how they represent friction.

The *balancing factors*  $A_i$  and  $B_j$  force conformity with the target trip generation values  $T_i$  and  $T_j$ . Initially, all  $B_j = 1$  and iteration occurs until the balancing factors converge.

A variation is the *singly constrained gravity model* that omits the  $B_j$  balancing factor. Some models also contain  $K$  factors to account for unusually high or low past interactions between some zone pairs.

Gravity models are not new. See Ref. 37 for an interesting paper about gravity model use over the past century. Most large MPOs use some form of gravity model.

- c. *Other Methods.* Although growth factor and gravity models are used in the majority of practical trip distribution applications, other methods exist. These include the Intervening Opportunities Model used in the Chicago area (Ref. 38), the Logit distribution model once tested by the San Francisco Metropolitan Transportation Commission, and the family of so-called *direct demand models*. See Ref. 27 for further detail on many of these methods.

## H. Mode Choice (Mode Split)

- 1 **General Considerations.** The first step is to decide which modes to consider. This depends on the analysis scale (see Sec. A).
  - a. While pedestrian and bicycle trips are important for local development planning, their specialized length and trip-maker characteristics cause these modes rarely to be considered in mode choice modeling.
  - b. The study purpose and the alternatives under consideration determine which modes are considered. In typical long-range urban area and corridor studies, it is common to consider two choices—private vehicles and public transit—or three choices—drive alone, ridesharing, and public transit. Sometimes a "nested" approach addresses sub-mode use, for example, estimating bus, rail, and ferry within overall transit use, or estimating two-person and three-plus groups within the overall ridesharing mode.
  - c. Transit "captives" may be identified and separately analyzed. Persons whose physical or economic situations foreclose the possibility of driving private vehicles often have distinct trip generation and distribution patterns, as well as other important travel needs. Thus, transit captive trips are often set aside from other trips at the trip generation step, and their analysis conducted in parallel to that of potential private vehicle drivers.
- 2 **Specific Methods.** Determining the proportions of trips using different transportation modes is done with either aggregate or disaggregate data analysis.
  - a. Aggregate relationships, such as using aggregate elasticity values to predict how overall transit ridership might change after a general fare increase, can give helpful rule-of-thumb estimates. See Ref. 7, pp. 141-144 for details. However, aggregate methods are not effective for estimating the results of complex service changes.
  - b. Disaggregate mode choice models, using data on individual mode choices in the context of individual trips, are accurate and economical tools when properly utilized. While disaggregate models can have many different mathematical forms, the most popular is the Logit model:

$$P_m = \frac{e^{V_m}}{\sum_{k=1}^N e^{V_k}} \quad [11.13]$$



where:  $P_m$  = the probability of choosing mode "m" for a particular trip,  
 $V_m$  = the "utility" of choosing mode "m" for that trip,  
 $e$  = the base of the natural logs ( $e^X$  is the Exponential Function),  
 $V_k$  = the utility of each of the alternative modes,  $k = 1, \dots, N$ . Generally, each mode's utility function is a linear combination of variables as follows:

$$V_k = a_0 + a_1 X_{k1} + a_2 X_{k2} + \dots + a_j X_{kj} \quad [11.14]$$

where the variables  $X_{kj}$  represent the:

- (1) characteristics of mode "k" for the trip being considered (travel time, travel cost, access time, etc.)
  - (2) characteristics of the person making that trip (income, household type, age, gender, etc.)
  - (3) characteristics of the trip itself (urgency of being on time, whether carrying baggage, etc.)
- and the  $a_j$ 's are parameters determined by calibration.

Logit models are calibrated using the maximum likelihood technique. Prediction of traffic by mode can be done "naively" by inputting forecasted average values of the model variables (the  $X_{kj}$ 's), or by means of market segmentation and sample enumeration methods, which give far more accurate forecasts. See Ref. 39 for additional details.

See Ref. 27 for guidance on using nested Logit models to forecast traffic when explicit sub-modes are considered.

## I. Route Choice and Traffic Assignment

Once the appropriate trip matrices are complete, vehicle-trips and person-trips by transit are assigned to routes in the appropriate highway and transit networks. Route choice is generally based on the assumption that persons choose routes to minimize the difficulty of travel, called "travel impedance." Impedance usually corresponds to travel time, but it might be a complex combination of time, out-of-pocket costs, service frequency, reliability, and other measures. Three basic approaches exist:

- 1 **Conventional single time period traffic assignment**, which allocates trips from a trip matrix to expected travel paths in the network. Usually the time period is the peak travel hour, although traffic assignments for the 24-hour day and for other time periods are also performed. A number of conventional assignment methods exist (see Ref. 27) including:
  - a. *All-or-Nothing Assignment*. Trips are simply allocated to the shortest route between each origin and destination pair (or split in the event of a tie). Since basic all-or-nothing assignment ignores congestion, it is inappropriate for most urban applications, although it may be useful in rural applications or as a sub-step of other methods.
  - b. *Equilibrium Assignment*. Trips are allocated iteratively, and network impedances are repeatedly adjusted until trips have found minimum-impedance routes and the impedances on the routes are consistent with their congestion. Equilibrium Assignment is the only one of a family of Capacity Constrained Assignment methods that is guaranteed to converge to a correct solution. The relationship between highway traffic and congestion is often quantified by the empirical BPR curve:

$$SPEED = \frac{FREESPEED}{1 + 0.15(V/C)^4} \quad [11.15]$$

where: SPEED = the estimated congested speed on a roadway link of the network,  
 FREESPEED = the free flow speed on that link,  
 V/C = the ratio of hourly traffic volume to the link's capacity.

Practitioners have sought to improve the accuracy of this long-used relationship, in part by tying into highway capacity methodologies (Refs. 40 and 41).

- c. *Stochastic Assignment*. Trips from each O-D pair are allocated not only to the best route but also to all other good routes in inverse proportion to how much longer each route is compared to the best. This approach tries to compensate for the lack of perfect knowledge and choice variability among travelers.
- 2 **Dynamic traffic assignment**, which considers time-varying demand matrices and allocations of trips among both routes and time periods within the peak. These methods recognize that long trips span multiple time periods during which traffic conditions at different locations change. Early dynamic assignment procedures were applied in Washington, D.C. (Ref. 42) and Ottawa, Canada (Ref. 43). Research in this area has recently emphasized modeling the effects of traveler response to advanced information technologies, and increasingly incorporates simulation concepts (Ref. 44).
  - 3 **Simulation assignment methods**. These are the "cutting edge" of traffic assignment. Although previously weak in modeling route choice behavior, simulation provides very accurate representation of how travel times vary with traffic congestion, dealing with queue propagation and downstream traffic metering by bottlenecks, which are effects ignored in conventional traffic assignment. Recently developed hybrids of dynamic assignment and simulation have overcome the past weaknesses related to route choice modeling.

Traffic simulations fall into three categories:

- a. *Macroscopic models*, which represent link traffic with aggregate relationships based on link flow, density, and speed,
- b. *Microscopic models*, which represent individual vehicles and their behavior using car-following and gap acceptance principles,
- c. *Mesosopic models*, which represent individual vehicles but model behavior using macroscopic principles in the form of speed-flow-density and shock wave relationships.

A recent review of available simulation software found that three of the most popular, CORSIM, VISSIM, and PARAMICS, all provide good results when properly calibrated (Ref. 45).

## J. Feedback

Assumptions are made throughout the process (see the row labeled "Assumptions" subject to feedback in Fig. 11-1). If the result of applying the models suggests some of these assumptions are in error, they must be changed, and some or all of the trip estimation process repeated. For example, when the network is congested, the travel frictions between zones may be quite different from those initially assumed. If this is the case, the distribution and mode choice steps should be repeated using the correct values.

## K. Traffic Forecasting for Local Developments and Individual Routes

For a particular proposed development or localized transportation improvement, traffic estimates may be made by simpler methods, although the underlying structure of the four-step estimation process still applies. Greater use may be made of growth factors and amounts of converted, diverted, and induced traffic adjusted manually.

- 1 **Area-wide traffic growth** may be estimated by several methods such as projecting past trends, correlating traffic growth with some economic index, or developing some kind of growth formula. City or regional planning agencies frequently provide growth factors of this type.
- 2 **Converted traffic** is that which previously used another mode of travel but changed to take advantage of a new or improved facility, such as a new bus route or transit station. Converted traffic can sometimes be estimated using cross-elasticity values derived from regional mode choice models.

- 3 **Diverted traffic** is that which changes from a previous route to a new or improved route without change in origin, destination, or mode of travel. Diversion curves may sometimes be used to estimate this traffic. These relationships tie traffic shares to the travel time and distance differences or ratios between competing routes. Ref. 46 gives one such relationship used extensively since the mid-1950s:

$$p = 50 + \frac{50(d + 0.8t)}{\sqrt{(d0.8t)^2 + 11.6}}, \text{ for } 0 \leq p \leq 100 \quad [11.16]$$

where:  $p$  = the percentage of trips between two points that will use the new route.

$d$  = the distance saved by using the new route.

$t$  = the time saved by using the new route.

Both  $d$  and  $t$  may be negative if the new/improved route is longer than the best existing route.

- 4 **Induced traffic** is that which did not previously exist in any form but which develops when new or improved transportation facilities reduce travel costs. Elasticity-based methods may be used to approximate the induced traffic that results solely from transportation improvements (see Ref. 47).

Site impact studies estimate changes in travel demand on a limited number of roadways and intersections. The object is to determine roadway capacity enhancements needed to handle the increased travel demand from nearby land use changes. These studies use standard trip generation rates (Ref. 33) but typically deal with trip distribution, mode choice (if a factor), and traffic assignment by factoring established patterns. In many applications, it is important to identify carefully the portion of trip generation consisting of bypass traffic, which increases turning movements but results in no net traffic increase on the adjacent roadways. Traffic estimation software packages (see Sec. E) that emphasize site impact studies include TMODEL, TEAPAC, TRANMAP, and TRAFFIX (see Ref. 22.).

#### REFERENCES

1. Outwater, Maren L. and William R. Loudon. "Travel Forecasting Guidelines for the Federal and California Clean Air Acts." *ITE Journal*, v. 65, no. 4, April 1995, pp. 25-31.
2. Harvey, Greig and Elizabeth Deakin. *A Manual of Regional Transportation Modeling Practice for Air Quality Analysis*. Washington, D.C.: National Association of Regional Councils [1993].
3. Los Alamos National Laboratory. TRANSIMS. On-line. Internet. September 2004. Available: <http://transims.tsasa.lanl.gov/>.
4. Edwards, John D. Jr. (Editor). *Transportation Planning Handbook*. Second Edition. Washington DC: Institute of Transportation Engineers, 1999.
5. Consad Research Corporation. *Impact studies, Northeast Corridor Transportation Project*: final report. Pittsburgh : CONSAD Research Corporation, 1967-1969.
6. Paul Taylor, Daniel S. Leavitt, and Kip D. Field. "California HSR Corridor Evaluation and Environment Constraints Analysis." *Journal of Transportation Engineering*. Vol. 123, no. 1 (Jan./Feb. 1997) pp. 1-11.
7. Schoon, John G. *Transportation Systems and Service Policy*. New York: Chapman & Hall, International Thompson Publishing, 1996. 198 pp.
8. Nash, Andrew Butler. "California's Congestion Management Program." *ITE Journal*. Vol. 62, no. 2 [Feb. 1992] pp. 29-32.
9. Rothblatt, Donald N. and Steven B. Colman. *An Experiment in Sub-Regional Planning : California's Congestion Management Policy*. Working paper 95-7. Berkeley, Calif.: Institute of Governmental Studies, University of California at Berkeley [1995] 34, [46] pp.

10. U.S. Department of Transportation, Federal Transit Administration. *Alternatives Analysis/Draft Environmental Impact Statement/Draft Environmental Impact Report for the BART-San Francisco International Airport Extension in Northern San Mateo County, California*. Oakland, CA: Metropolitan Transportation Commission [1992] 2 v.
11. Bochner, Brian S. *Traffic Access and Impact Studies for Site Development*. Washington, DC: Institute of Transportation Engineers, 1991, 52 pp.
12. GIS/Trans Ltd. *Transportation Case Studies in GIS*. Flyer. Washington, DC: U.S. Federal Highway Administration, Travel Model Improvement Program, 2 pp. On-line. Internet. September 2004. Available: <http://tmip.fhwa.dot.gov/clearinghouse/docs/gis/flyer/>.
13. Linnartz, J.P.M.G., M. Westerman and R. Hamerslag. "Monitoring the San Francisco Bay Area Freeway Network Using Probe Vehicle and Random Access Radio Channel." Research Report, UCB-ITS-PRR-94-23, Richmond, Ca.: California PATH. October 1994.
14. Transportation Research Board. *Census Data for Transportation Planning*. Washington DC: Nat'l. Acad. of Sciences, Sep. 24, 2003. On-line. Internet. Sep. 2004. Available: <http://www.trbcensus.com/ctpp.html>.
15. U.S. Census Bureau. Home Page. On-line. Internet. September 2004. Available: <http://www.census.gov/>.
16. U.S. Federal Highway Administration. *Standard Land Use Coding Manual*. Washington, DC: U.S. Government Printing Office. [1977] 111p.
17. Demographic Research Unit. Home Page. Sacramento CA: California Dept. of Finance, 2003. On-line. Internet. September 2004. Available: <http://www.dof.ca.gov/HTML/DEMOGRAP/Druhpar.htm>.
18. Oryani, K. and B. Harris. *Review of Land Use Models and Recommended Model for DVRPC*. Philadelphia PA: Delaware Valley Regional Planning Commission, Sep. 1996. On-line. Internet. Sep. 2004. Available [http://tmip.fhwa.dot.gov/clearinghouse/docs/landuse/compendium/dvrpc\\_toc.stm](http://tmip.fhwa.dot.gov/clearinghouse/docs/landuse/compendium/dvrpc_toc.stm).
19. U.S. Dept. of Transportation, U.S. Environmental Protection Agency. *Travel Survey Manual*. Washington, DC: Travel Model Improvement Program, FHWA-PL-96-029 [1996], 309 pp.
20. Richardson, A. J., E. S. Ampt, and A. H. Meyburg. *Survey Methods for Transport Planning*. Parkville, Victoria, Australia: Eucalyptus Press, 1995. 458 pp.
21. SG Associated Inc. *Workbook for Estimating Demand for Rural Passenger Transportation*. Washington, DC: Transportation Research Board, Transit Cooperative Research Program Report 3 [1995]. 123 pp.
22. Chang, C.L. and D.T. Meyers. "Transportation Models." Chapter 6 in: Edwards, J.D. Jr. (Editor). *Transportation Planning Handbook*. Second Edition. Washington DC: Institute of Transportation Engineers, 1999. Table 6-3.
23. Ng, Jerry C. N. and Paul M. Sarjeant. "Use of Direct Data Entry for Travel Surveys." *Transportation Research Record* 1412, 1993, pp. 71-79.
24. Lau, Samuel. *Truck Travel Surveys: A Review of the Literature and State-of-the-Art*. Oakland, CA: San Francisco Metropolitan Transportation Commission, 1995.
25. Engelke, Lynette J. *Activity-Based Travel Forecasting Conference*. Washington, DC: U. S. Federal Highway Administration, Travel Model Improvement Program, Texas Transportation Institute, Feb. 1997, 201 pp. On-line. Internet. Sep. 2004. Available: <http://tmip.fhwa.dot.gov/clearinghouse/docs/abtff/>.
26. Cambridge Systematics, Inc. *Vehicle Availability Modeling*. Washington, DC: U.S. Federal Highway Administration, May 1997. On-line. Internet. Sep. 2004. [http://ntl.bts.gov/card\\_view.cfm?docid=7606](http://ntl.bts.gov/card_view.cfm?docid=7606).
27. Ortúzar, J. de D. and L. G. Willumsen. Hutchinson, B.G. *Modeling Transport (3rd Edition)*. Chichester, England: J.W. Wiley & Sons, 2001, 499 pp.

28. Texas Transportation Institute. *Metropolitan Transportation Planning Issues: A Primer/Anthology for Small and Medium MPOs*. Washington, DC: U.S. Federal Highway Administration, Travel Model Improvement Program, Apr. 1999. On-line. Internet. Sep. 2004. Available: <http://tmip.fhwa.dot.gov/clearinghouse/docs/general/sams/>.
29. JHK & Associates. *State of California DOT Travel Forecasting Guidelines*. Emeryville CA: November 1992. 106 pp.
30. Transportation Research Board. *Quick Response Urban Travel Estimation Techniques and Transferable Parameters User's Guide*. Washington DC: NCHRP Report 187 [1987].
31. *McTran Newsletters*. Gainesville, FL: Center for Microcomputers in Transportation, Transportation Research Center, University of Florida, On-line. Internet. Sep. 2004. Available: <http://mctrans.ce.ufl.edu/>.
32. U. S. Department of Transportation. *Travel Model Improvement Program (TMIP) Newsletter*. Arlington Texas: Texas Transportation Institute. Occasional publication. On-line. Internet. September 2004. Available: <http://tmip.fhwa.dot.gov/clearinghouse/>.
33. Institute of Transportation Engineers. *Trip Generation*. 7th Ed. Washington, DC: Report, 2003, 1700 pp.
34. Institute of Transportation Engineers. *Trip Generation Handbook*. 2nd Ed. Washington, DC: Report, 2004, 164 pp.
35. Kellerco Consultants. *Development and Application of Trip Generation Rates – Final Report*. Washington, DC: U. S. Department of Transportation, January 1985. On-line. Internet. September 2004. Available: [http://ntl.bts.gov/card\\_view.cfm?docid=7000](http://ntl.bts.gov/card_view.cfm?docid=7000).
36. DKS Associates. *Travel Model Development and Refinement – Trip Generation – Final Report*. Seattle WA: Puget Sound Regional Council, June 1994. On-line. Internet. September 2004. Available: [http://ntl.bts.gov/card\\_view.cfm?docid=7141](http://ntl.bts.gov/card_view.cfm?docid=7141).
37. Carrothers, Gerald, A.P. "An Historical Review of the Gravity and Potential Concepts of Human Interaction," *Journal of the American Institute of Planners*, v. 22, no. 2, Spring 1956, pp. 94-102.
38. Ruiter, Earl R. "Toward a Better Understanding of the Intervening Opportunities Model." *Transportation Research*, v. 1, 1967, pp. 47-56.
39. Horowitz, J. L., F. S. Koppelman, and S. R. Lerman. *A Self-Instructing Course in Disaggregate Mode Choice Modeling*. Washington, D.C.: U. S. Federal Transit Administration, DOT-T-93-18, Dec. 1986.
40. Horowitz, Alan J. *Delay-Volume Relationships for Travel Forecasting, Based on the 1985 Highway Capacity Manual*. Washington, D.C.: U. S. Federal Highway Administration, FHWA-PD-92-015, March 1991.
41. Singh, Rupinder. *Beyond the BPR Curve: Updating Speed-Flow and Speed-Capacity Relationships in Traffic Assignment*. Oakland, CA: Metropolitan Transportation Commission, 1990 MTC Regional Travel Demand Model Development Project, April 1995.
42. de Romph, E., H. J. M. van Grol, and R. Hamerslag. "Application of Dynamic Assignment in Washington, D.C., Metropolitan Area." *Transportation Research Record 1443*, 1994, pp. 100-109.
43. Rilett, Laurence R. and Christine M. Benedek. "Traffic Assignment Under Environmental and Equity Objectives." *Transportation Research Record 1443*. Washington D.C.: Transportation Research Board [1994], pp. 92-99.
44. Abdelghany, Khaled F, et al. "Real-Time Dynamic Traffic Assignment and Path-Based Signal Coordination – Application to Network Traffic Management." *Transportation Research Record 1667*. Washington D.C.: Transportation Research Board [1999], pp. 67-76.

45. Park, B.B. and Qi. H. *Development and Evaluation of a Calibration and Validation Procedure for Microscopic Simulation Models*. Charlottesville VA: Virginia Transportation Research Council, Virginia Department of Transportation & the University of Virginia, 2004. On-line. Internet. September 2004. Available: [http://www.virginiadot.org/vtrc/main/online\\_reports/05-cr1.htm](http://www.virginiadot.org/vtrc/main/online_reports/05-cr1.htm).
46. Moskowitz, Karl. "California Method of Assigning Diverted Traffic to Proposed Freeways." *Highway Research Board Bulletin 130*. 1956, pp. 1-26.
47. Lee, Douglass B., Jr. "Demand Elasticities for Highway Travel." Appendix B. in HERS-ST V2.0: Highway Economic Requirements System-State Version Technical Report (Draft). Washington DC: U.S. Federal Highway Administration. USDOT. Report. On-line. Internet. September 2004. Available: <http://www.fhwa.dot.gov/infrastructure/asstmgmt/hersindex.htm>.



### A. Scope and Basic Requirements for Transportation Planning

- 1 **Scope.** Transportation planning includes the study of today's transportation needs in relation to present population, economy, and land use; the identification of future transportation needs given predictions of future population, land use, and economy; the development and evaluation of alternative transportation improvements; and the adoption of a transportation plan with provisions for implementation, scheduling, and financing.
- 2 **Legal Authority.** Federal code states it is in the national interest to conduct transportation planning at both the metropolitan and state levels (Ref. 1). Such activities are required for participation in federal transportation funding programs.

Since the 1990 Clean Air Act Amendments (CAAA), transportation conformity requirements intended to achieve national air quality standards have significantly influenced the institutional framework and technical processes of transportation planning (Ref. 2). Additional significant change resulted from the Congestion Mitigation and Air Quality Program authorized by the 1991 Intermodal Surface Transportation Efficiency Act (ISTEA) and re-authorized in the 1998 Transportation Equity Act for the 21st Century (TEA-21) (Refs. 3 and 4), as well as from state congestion mitigation guidelines enacted during the past decade (Ref. 5). Transportation planning must also meet requirements of the 1990 Americans with Disabilities Act (ADA).

The institutional and procedural details of transportation planning are modified for the scale of the area studied, which range from multi-state to local site impact studies (see Chap. 11, Sec.A).

- 3 **Basic Requirements for Transportation Plans.** Federal code states that both metropolitan and statewide transportation planning should "provide for the development and integrated management and operation of transportation systems and facilities (including pedestrian walkway and bicycle transportation facilities) that will function as an intermodal transportation system for the [area] and as an integral part of an intermodal transportation system for the [larger region in which the area is located]" (Ref. 1). Both the metropolitan and statewide processes shall consider projects and strategies that:
  - a. Support economic viability.
  - b. Increase transportation safety and security.
  - c. Increase accessibility and mobility options.
  - d. Protect and enhance the environment, conserve energy, and improve quality of life.
  - e. Enhance intermodal and intramodal integration and connectivity.
  - f. Promote efficient management and operation.
  - g. Emphasize preservation of the existing system.



## B. Metropolitan Planning (for additional detail, see Refs. 6 through 9)

Since 1962, federal legislation has made it a condition for receiving federal aid for highway projects in urban areas with populations of over 50,000 that such projects be based on a continuing, cooperative, and comprehensive transportation planning process. Federal aid for mass transit has set similar conditions since 1964. A metropolitan planning organization (MPO) is designated to conduct the transportation planning process for each urbanized area of more than 50,000 people. Under the provisions of ISTEA and TEA-21, FHWA and FTA have established specific guidelines for the type of studies to be carried out. Some of these are summarized below.

- 1 **The Three Cs.** These refer to the attributes "continuing," "cooperative," and "comprehensive" mandated by the federal legislation.
  - a. *Continuing.* The planning process must be a continuing activity, represented by the technical activities listed in B.2. below.
  - b. *Cooperative.* Federal regulations require the planning process to be assigned to an (MPO), which includes representatives of local government, public transportation operating agencies, and appropriate state officials. The MPO is designated by the state's governor in cooperation with local agencies. Plans must be coordinated with the clean air agencies and seek comment from affected public and private organizations, and citizens in general.
  - c. *Comprehensive.* A study is considered sufficiently comprehensive if it includes all requirements and elements listed in the following paragraphs and covers the entire urbanized area.
- 2 **Requirements of the Planning Process.** Long-range transportation planning must, as a minimum:
  - a. Identify the transportation facilities in the integrated system, giving emphasis to those that serve important national and regional transportation functions.
  - b. Contain a financial plan that demonstrates how the transportation plan can be implemented, including both public and private resources.
  - c. Assess capital investments and other measures to preserve, rehabilitate, and make most efficient use of the existing system.
  - d. Indicate proposed transportation enhancement activities.
- 3 **Overall Activities of Transportation Planning.** ISTEA, as updated by TEA-21, requires that the planning process incorporate the following products and activities:
  - a. A *Transportation Plan* for each urbanized area of more than 50,000 people, covering at least a 20-year planning horizon. The plan includes both long-range and short-range strategies and actions leading to the development of an integrated multimodal transportation system to facilitate efficient movement of people and goods. The plan must be updated every five years, or every three years in air quality non-attainment or maintenance areas.
  - b. A *Transportation Improvement Program*, (TIP) to be updated at least every two years. The TIP is a prioritized program of transportation improvement projects or project segments covering three years or more, consistent with the Transportation plan and including a financial element that constrains the TIP to be consistent with the available public and private funding sources. Development of the TIP shall offer citizens, agencies, and other interested parties the opportunity to comment on the proposed program. Each metropolitan TIP automatically becomes part of the corresponding statewide TIP (the STIP).
  - c. A *Transportation Management Area* (TMA) is designated for each urbanized area with a population over 200,000, or where requested by local authorities. The Transportation Plan for a TMA includes a Congestion Management System (CMS) that provides for effective management of facilities through the use of travel demand reduction and operational management strategies.

- d. *Transportation conformity* is a provision of federal legislation that requires urban areas in non-attainment of federal air quality standards to forecast travel demand and emissions and show how, over time, air quality will be brought into compliance with the emissions "budget" of the State Implementation Plan (SIP). Non-attainment and former non-attainment areas (known as maintenance areas) are eligible for federal Congestion Mitigation and Air Quality Improvement Program funds for transit and traffic improvements, fleet conversions, and demand management strategies designed to reduce emissions.
- e. Other planning and project development activities deemed necessary by state and local officials to address transportation issues in the area. Note that the former ISTEA requirement to conduct stand-alone Major Investment Studies (MIS) for proposed major area-wide or corridor transportation improvements was changed by TEA-21 to accommodate those proposals within the normal transportation planning activities and the corresponding environmental impact (NEPA) studies (see Chap. 29).

#### 4 Specific Technical Activities.

- a. Analysis of existing travel conditions, transportation facilities, and systems management.
- b. Evaluation of alternative management improvements (see Chap. 34).
- c. Projection of regional economic, demographic, and land use activities consistent with regional development goals, and of potential transportation demands based on these activities (see Chap. 11).
- d. Estimation of the distribution of costs and impacts of transportation alternatives on various segments of the population (see Sec. E, below).
- e. Analysis of alternative transportation investments to meet regional needs.
- f. Refinement of the transportation plan through corridor transit technology and staging studies.
- g. Sub-area feasibility, location, legislative, fiscal, functional classification, and institutional studies.
- h. Monitoring and reporting of urban development and transportation indicators, and regular reappraisal of the transportation plan.
- i. Implementation planning.

### C. Statewide Planning (for additional detail, see Refs. 6 and 7)

Prior to the development of the Interstate Highway System, state agencies were involved primarily with rural highways. The 1950s brought a shift to the construction of the Interstate System. By the late 1960s and early 1970s, state agencies were, emphasizing a mix of modes to serve developing urban areas and to deal with problems created by abandonment of railroad services and lines, as well as airline service to remote small communities.

States are now required to coordinate transportation planning among their various metropolitan areas as well as are specifically charged with developing the transportation portions of the State Implementation Plans (SIPs) per requirements of the 1990 CAAA. States also coordinate transportation planning outside of metropolitan areas and perform special studies related to modal issues and intercity mobility.

#### 1 Additional Areas of Emphasis

- a. Establish a balanced and integrated state system that meets the needs of the people.
- b. Serve trips entering, traversing, or leaving the state.
- c. Develop corridors connecting urban areas with rural populated areas.
- d. Provide facilities for rural areas with significant numbers of trips.

2 **Planning Activities.** Federal code requires that the statewide transportation planning process address the following:

- a. A long-range State Transportation Plan with at least a 20-year horizon, describing policies, strategies, and facilities or changes in facilities proposed for all modes of transportation. The plan must be continuing, cooperative, and comprehensive. Special importance is placed on the financial aspects of implementing the plan.
- b. A State Transportation Improvement Program (STIP) meeting the same requirements described in B.3.b., which must be adopted at least every two years. Projects shall be consistent with the long-range plan and conform to the Clean Air Act. Projects for areas of fewer than 50,000 people are selected by the state in cooperation with local officials.
- c. Other planning and project development activities deemed necessary by state and local officials to assist in addressing transportation issues.

### D. Functional Classification of Facilities

An important aspect of transportation planning at all levels, especially in developing the circulation elements of urban general plans, is the functional classification of the jurisdiction's streets and highways. Each urban general plan should establish such a classification.

Transportation facilities are classified by the relative importance of their mobility and access functions. The access function typically conflicts with the mobility function and vice versa. In the hierarchy of highway facilities (Fig. 12-1), freeways and major (arterial) streets make up the major highway system, which is provided primarily for mobility, while collector and local streets make up the local street system, which functions primarily to provide land access. (Ref. 10, Chap. 11). Functional classification requires a policy determination for each street section of how much the access function is emphasized at the cost of efficient movement, or de-emphasized to improve mobility. Similarly, in mass transit networks, express routes are designed primarily to expedite mobility, while local routes provide access. Each classification is discussed in more detail below.

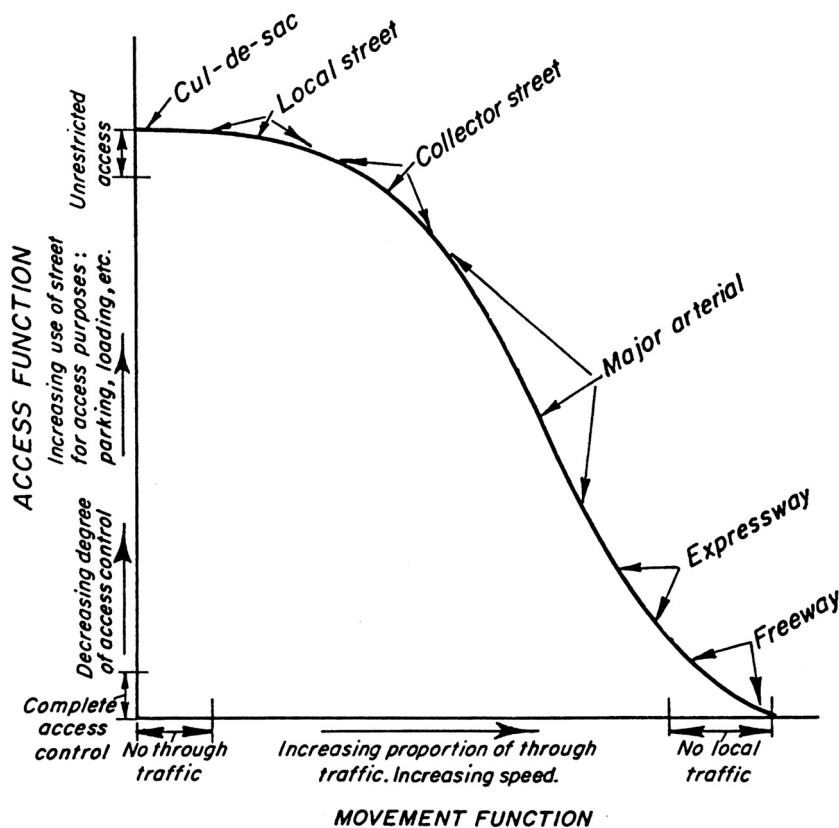

Fig. 12-1- Schematic Relationship between the Access and Mobility Functions of Streets

## 1 The Major Highway Network.

### a. *Types of Major Highways.*

- (1) *Controlled Access Highways.* Highways to which owners of abutting lands have no right or easement of access.
  - (a) *Freeways.* Highways devoted entirely to efficient traffic movement, performing no land access function and on which all crossing conflicts are removed by grade separation.
  - (b) *Parkways.* Highways in parks or ribbons of park-like development generally restricted to noncommercial vehicles.
  - (c) *Expressways.* Access-controlled highways which may or may not be divided or have grade separations at intersections.
- (2) *Major (Arterial) Highways (Streets).* Facilities on which geometric design and/or traffic control measures are used to expedite through traffic, with access to abutting property sometimes restricted, but not eliminated.
  - (a) New street systems can be laid out in such a manner that property faces away from arterials toward adjacent local streets. Direct access to and from the arterials then becomes unnecessary.
  - (b) Existing streets and highways can accommodate through traffic restricting or prohibiting parking and loading at the curb (a form of access) in the interest of improving traffic flow. Abutting land still has access via driveways. Limiting the number of driveways, installing median barriers, and creating adequate separation between driveways and intersections are further tools for enhancing mobility. These principles have received substantial research attention in recent years and are compiled in the new TRB Access Management Manual (see Refs. 11 and 12).

### b. *Planning Objectives*

- (1) To concentrate through traffic on a network of freeways and major streets which can handle it.
- (2) To accommodate through traffic at higher speeds, which is possible when conflicts with local access traffic are minimized or eliminated.
- (3) To separate through traffic from residential and other local land uses, where it is often dangerous and objectionable.
- (4) To reduce the number of intersections where traffic volumes are so high as to cause significant delays or potentially dangerous situations, requiring elaborate control devices.

### c. *Plans*

- (1) Plans are based on traffic projections and assignments, using the methods described in Chap. 11. An integral part of the procedure for developing the plan is the selection of the major highway type for each link in the network, based on the capacity needed to accommodate assigned traffic volumes. Alternate highway types and alternate locations of roadways, interchanges, etc. must be tested to find the most acceptable solution.
- (2) Major highways should not cut through communities, but can sometimes act as buffers between different communities and incompatible land uses. The effect of nearby major highways, such as noise impacts, on different types of land uses must be considered.
- (3) The major highway system must be coordinated with:
  - (a) The local street system (see Fig. 12-2 and Sec. D.2. below).
  - (b) Other transportation modes, e.g., public transit (Sec. D.3. below).
  - (c) Transportation terminals and parking (Sec. D.4. below).

## 2 The Local Street System.

### a. *Types of Local Streets*

- (1) *Local Streets.* Facilities having the principal function of providing access to immediately adjacent land. Local streets may be divided into subclasses according to the type of land they serve; residential, industrial, and commercial.
- (2) *Collector Streets.* Streets that expedite traffic movements within neighborhoods and connect with the major highway system. Collectors are not intended to handle long through trips, and they perform the same land access function as local streets. Traffic control devices may be installed to protect or facilitate traffic on collector streets, although these would normally not be as elaborate as those on major streets.

### b. *Planning Objectives*

- (1) To provide access to private land by:
  - (a) Connecting individual parcels of land to the street system via driveways.
  - (b) Providing access and circulation for pedestrians through sidewalks.
  - (c) Providing access for vehicle occupants and goods through parking and loading zones on streets adjacent to developed land.
- (2) To provide safe conditions by discouraging through traffic and high speeds.

### c. *Plans*

- (1) Standards are established for local streets (see Chap. 17).
- (2) Existing local streets that carry excessive through traffic or experience undesirably high speeds can be redesigned to reduce these consequences (see Chap. 34, Sec. E. and Refs. 13 and 14).
- (3) New residential neighborhoods can be laid out in irregular patterns, including use of cul-de-sacs (bottom left in Fig. 12-2). Houses may be sited to face on pedestrian walks, with vehicular access at the rear via alleys.
- (4) Localities may also seek to develop local circulation systems employing principles of transit-oriented development, defined as "A compact, mixed-use community, centered around a transit station that, by design, invites residents, workers, and shoppers to drive their cars less and ride mass transit more." (Ref. 15). Extensive information is available on this approach as documented by the recently completed TCRP Project H-27 (see Ref. 16).
- (5) Existing local streets not meeting basic standards should be programmed for improvement through construction of sidewalks, all-weather surfaces, or curbs and gutters. Owners of abutting properties may be required to finance part or all of such improvements.

## 3 The Public Transit Network.

### a. *Planning Objective.* To provide a hierarchy of public transportation facilities which balances needs for both access and mobility.

### b. *Plans*







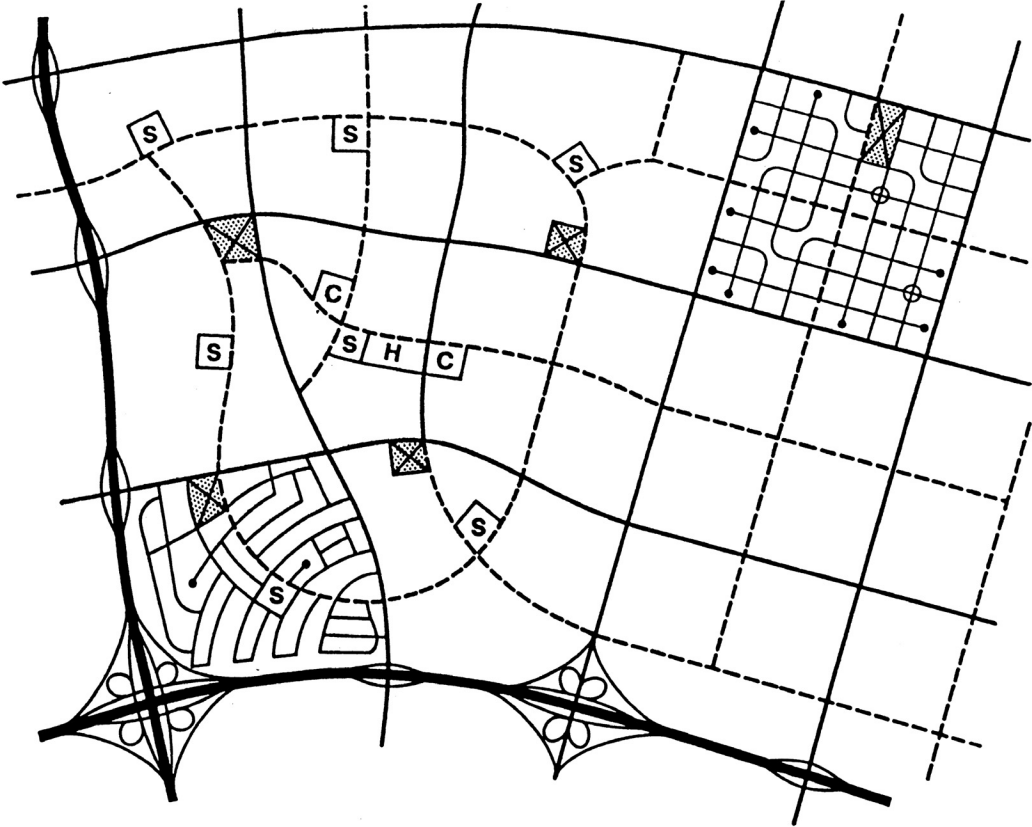

- (1) Since the quality of transit service is a major factor in determining transit patronage, several alternative transit plans should be compared. Policy criteria must be determined on which comparisons can be based.
- (2) Economic evaluation of transit alternatives must include operating costs, which play a much more critical role in transit than in highway systems (see Sec. E below).
- (3) Financial studies must determine possible sources of funds for transit construction and operation.
- (4) Location of "arterial" transit routes — rail transit, express buses — must be coordinated with the major highway system. Rail routes can sometimes be located within or adjacent to freeways, although this presents difficulties in the design of stations, and

it may result in unsatisfactory locations for picking up and delivering transit passengers. Express buses, of course, make use of the arterial highway and freeway system.

- 4 **The Terminal Facilities Component.** A transportation network will not operate adequately if insufficient provision is made for passenger and freight transfer and for vehicle storage at the ends of trips. Plans for the location, financing, and design of parking and loading facilities and off-street transit terminals should be included in the comprehensive plan.



**LEGEND**

- |                                                                                                                |                                                                                                         |
|----------------------------------------------------------------------------------------------------------------|---------------------------------------------------------------------------------------------------------|
|  SHOPPING CENTER            |  FREEWAYS           |
|  PRIMARY SCHOOL             |  MAJOR ARTERIALS    |
|  HIGH SCHOOL                |  COLLECTORS STREETS |
|  COMMUNITY CENTER OR CHURCH |  LOCAL STREETS      |

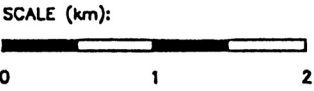

**Fig. 12-2. Hierarchy of Highway Facilities in a Residential Area**  
(Local Streets shown only partially)

## E. Project Planning/Benefit-Cost Analysis

Although most often applied at the project planning level, *Benefit-Cost Analysis* (BCA) is applicable at all levels of planning as the preferred method of selecting among available alternatives. BCA measures and ranks mutually exclusive investment alternatives, taking into account their economic impacts, regardless of whether or not the impacts are captured in financial accounts. BCA considers only the economic aspects of the decision at hand. Financial, social, and other considerations must also be addressed through additional methodologies. There are many pitfalls in setting up and carrying out a benefit-cost analysis correctly. A recently developed on-line guide to BCA addresses most of these (see Ref. 17). Ref. 18 and 19 also cover many of these principles in detail, with particular regard to transportation planning applications. Ref. 20 provides background on benefit-cost analysis in general and on related issues such as capital budgeting, where the alternatives are not mutually independent.

### 1 The Steps of Benefit-Cost Analysis (BCA):

- a. Identifying the problem or opportunity, and the relevant issues.
- b. Establishing a base case alternative against which to compare options.
- c. Identifying alternative investment options which are comparable, self-contained, and independent of each other.
- d. Estimating the time stream of economic costs of the alternatives over a common time frame.
- e. Estimating the time stream of economic benefits of the alternatives over the same time frame.
- f. Applying discounting to calculate the total costs and benefits for each alternative at a single point in time.
- g. Quantifying the relative merits of the alternatives with one or more of the accepted engineering economic indicators (e.g., Net Present Worth, Benefit-Cost Ratio, Internal Rate of Return).

2 **Defining Costs.** In BCA, costs quantify the resources consumed in the course of implementing each alternative. Costs include initial investment, usually ongoing maintenance and operations through the project life, salvage or closeout costs, possibly some expenditures incurred by project users (such as required equipment and terminal facility upgrades), and costs borne by third parties (external costs, which include environmental costs). All costs that differ among alternatives should be included, regardless of who incurs them. Sometimes, costs are not based on prevailing prices, since the proper notion of economic cost is opportunity cost, that is, the value of the resources consumed in their best alternate use. As a rule, inflation should not be considered in estimating future costs; prices should be fixed to those of a particular year.

3 **Defining Benefits.** In BCA, benefits quantify the intended outcomes of the investment, such as lower transportation user costs due to time saved, reduced vehicle operating costs, accident reductions, environmental benefits, and productivity gains to the economy to the extent these are not captured in reduced user costs. As with costs, all benefits that differ among alternatives should be included, regardless of who incurs them. Full quantification of benefits is often challenging, since there may be no well-established valuation method for certain outcomes, e.g., the value of noise reduction from constructing sound walls. A recent update of the classic 1977 *AASHTO Red Book* (Ref. 21) addresses the quantification of highway benefits in detail. Sometimes, a willingness-to-pay analysis is used to value non-market benefits (see Ref. 18, Chap. 7).

4 **Discounting.** Cost streams and benefit streams extending through the project lifetime are discounted to a common point in time, usually the present. The present value of a cost incurred "N" years in the future is calculated by:

$$C_{PV} = \frac{C_N}{(1+i)^N} \quad [12.1]$$

where:  $C_{PV}$  is the equivalent present value of the cost.

$C_N$  is the actual value of the cost at the time it occurs ( $N$  years in the future).

$N$  is the number of years in the future when the cost occurs.

$i$  is the *discount rate*, which represents the annual real opportunity cost of money (analogous to a real interest rate, i.e., interest in excess of inflation).

Other discounting formulas are available, for example, to calculate the present value of a uniform stream of equal costs (or benefits) incurred every year for a number of years.

**5 Engineering Economy Measures.** Once all costs and benefits for each alternative have been discounted and summed to yield a single value of total costs ( $TC_{PV}$ ) and of total benefits ( $TB_{PV}$ ), the relative merits of the alternatives may be quantified using one of the common engineering economy measures:

a. *Net Present Worth*  $NPW = TB_{PV} - TC_{PV}$  [12.2]

b. *Benefit-Cost Ratio*  $B / C = TB_{PV} / TC_{PV}$  [12.3]

c. *Internal Rate of Return (IRR)*, which is the discount rate at which  $TB_{PV} = TC_{PV}$ .

For ideological or historical reasons, different organizations may have policies mandating use of particular engineering economy measures, including the common measures listed above and others.

The selection of the engineering economy measure is unimportant if an *incremental challenger-defender* approach is used. The incremental approach to benefit-cost analysis proceeds as follows:

- a. Identify the base case alternative as the *defender*, that is, the option to beat.
- b. Pick a *challenger* from among alternatives not yet considered. The challenger should be the remaining alternative with the smallest present value of total costs.
- c. Calculate the incremental costs and incremental benefits of picking the challenger over the defender, that is, calculate the **difference** between the alternatives' benefits and between their costs, subtracting the values for the defender from those of the challenger.
- d. Calculate the engineering economy measures based on the incremental costs and incremental benefits. The challenger is then selected in preference to the defender if:
  - (1) The incremental  $NPW$  is greater than zero.
  - (2) The incremental  $B/C$  ratio is greater than one.
  - (3) The incremental IRR is greater than the required minimum discount rate.
- e. If the challenger is selected, it replaces the defender as the option to beat. If some alternatives remain to be considered, then return to step b. Otherwise, the last defender "left standing" is the best economic choice. The entire process may then be repeated to determine the 2<sup>nd</sup> best, 3<sup>rd</sup> best, etc.

The advantage of incremental benefit-cost analysis is that it gives the same ranking of alternatives, regardless of which engineering economy measure is utilized.

**6 BCA Models.** Computer models are available to help organize data and calculate benefits and costs for transportation projects. Many are listed below. For further details, see the Models page in Ref. 17.

- a. Cal-B/C, developed by Caltrans, is an easy-to-use Excel spreadsheet for benefit-cost analysis of highway and transit projects in corridors that already contain highway facilities or transit services. Defaults are provided for California conditions.
- b. MicroBENCOST provides BCA for 7 types of corridor highway improvements: (1) capacity enhancement, (2) bypass construction, (3) intersection or interchange improvement, (4) pavement rehabilitation, (5) bridge improvement, (6) highway safety improvement, and (7) railroad grade crossing improvement.



- c. STEAM evaluates multimodal urban transportation investments and policy alternatives at the regional and corridor levels. This model is closely linked to outputs from the 4-step urban transportation modeling process (see Chap. 11).
- d. HERS-ST is an optimization framework for analyzing investment strategies to maintain and improve existing highway networks. HERS is closely linked to the Highway Performance Monitoring System.
- e. StratBENCOST is a strategic evaluation method for BCA of investment alternatives to expand and improve a highway system. A strength of this model is its explicit consideration of uncertainty in input parameters. The program performs both single-segment and network-level evaluation.
- f. IDAS is a tool for BCA of projects involving Intelligent Transportation System technologies. Another model, SCRITS, provides a subset of the capabilities found in IDAS.
- g. NET\_BC is a tool for BCA of alternatives based on outputs from the 4-step urban transportation planning modeling process.
- h. RAILDEC is a strategic decision-support tool for evaluating rail and rail-related intermodal projects.
- i. ABC - A Microsoft Access application incorporating FAA procedures for BCA of airport projects.
- j. SPASM is a spreadsheet application for multimodal corridor-level project evaluation at the sketch planning "screening" level of detail. IMPACTS and SMITE are other spreadsheet applications for preliminary screening of corridor alternatives. SMITE-ML evaluates managed lanes proposals.

## F. Some Problems in Plan Implementation

- 1 **Land Use-Transportation System Conflicts.** There is an inherent conflict in the fact that land use decisions are typically made by local jurisdictions, whereas transportation system planning is carried out at the regional level. Land use, therefore, reflects local goals and concerns, whereas the transportation planning process attempts to reflect regional consensus.

Land use plans do not remain frozen, but require reevaluation and revision at regular intervals. However, there is often local pressure for rezoning on an ad hoc basis. Within the span of a typical transportation plan scenario — say, 20 years — there may be many land use changes that warrant making revisions to the transportation program.

- 2 **Transportation Plan Implementation.** Since the backbone of any urban transportation system involves federal aid, major investments in highways and mass transit facilities must be in accordance with an adopted plan. However, failure to conform to overriding air quality regulations or lack of funds may cause some plan elements to be postponed or abandoned.
- 3 **Lack of Common Objectives Within a Region.** In some places, plan alternatives have been developed, but the agencies involved have been unable to agree on the final selection. Local authorities see regional transportation problems through local eyes, and there is considerable resistance to implementing regional solutions perceived as contrary to local interests.
- 4 **Lack of Coordination in Implementation.** While planning may be comprehensive and coordinated, implementation is not. Commonly, freeways, local streets, parking, truck terminals, mass transit and other elements of the transportation system are the responsibility of separate agencies. The sources of funds for plan implementation are diffuse, and the amounts of available funding vary. For example, in California, the emergence of "sales tax counties," which set their own priorities for local highway and transit projects, has resulted in a reordering of priorities and the addition of new projects not in the original regional plans.
- 5 **General Antipathy to New Transportation Facilities.** There may be substantial public or political sentiment against any new highway or transit developments. Fears about induced growth in an area, adverse environmental impacts, use of scarce resources, and increased taxes

may outweigh the perceived benefits. As a result, programs may be cut in legislative halls, vetoed at the ballot box, or stalled in the courts.

- 6 **Public Attitudes Toward Different Transportation Modes.** Implementation is often slowed or even halted by opposition to particular types of transportation by user, industry, citizen, or political groups. Whereas planners can make fairly objective estimates of the use to be made of different modes through modal split techniques (see Chap. 11), non-tangible and external effects are difficult to define and become subject to argument. Both highway and transit systems have their over-enthusiastic supporters and irrational detractors.
- 7 **Opposition to Specific New or Expanded Facilities.** Even when there is general support for transportation improvements, individuals and groups may not want these improvements in their particular environment (e.g. the NIMBY, Not-In-My-Back-Yard, syndrome). Objections often raised against major new facilities, such as freeways, rail transit lines, and terminals include:
  - a. Loss by individuals of their property, even though they are adequately compensated. Often, equivalent housing at the market value of the lost property is not available, or business opportunities cannot be found in new locations.
  - b. Loss of housing by low-income residents. This is an especially difficult problem because it often seems reasonable to select corridors with low land values for new facilities. There is usually a shortage of suitable substitute homes that low-income families can afford.
  - c. Possible or alleged harmful effects on adjacent real estate values or on the character of the neighborhood.
  - d. Fear of environmental degradation, especially increased noise, and harm to historical and scenic landmarks.
  - e. Withdrawal of property from the tax rolls and the resulting decrease in local tax revenues.

Some of these problems can be alleviated or solved by joint development of rights of way, including the use of air rights above freeways and rail transit lines and, in some circumstances, development below elevated transportation structures. Such development may permit replacement of housing or business space in the same neighborhood, can reduce the unfavorable impact of the transportation facility by shielding its appearance, noise, and odors, and can generate revenues for both the transportation agency and the local taxing jurisdictions. Public attitudes have also forced transportation designers to devote more attention to the aesthetics of route location and design. The extra costs required for enhancing community facilities, landscaping, special architectural treatment, and other visual improvements are now considered justifiable project costs in many locations.

## REFERENCES

1. *23 U.S. Code*, Chapter 1, § 134 and § 135. Updated February, 2000. Internet. September 2004. Available: <http://www.fhwa.dot.gov/tea21/legis.htm>.
2. Howitt, Arnold M. and Elizabeth M. Moore. "Implementing the Transportation Conformity Regulations." *Transportation Research News*. Washington, DC: Transportation Research Board, v. 202, May-June 1999, p. 15-23 et seq.
3. U.S. Government. *Intermodal Surface Transportation Efficiency Act of 1991*. Public Law 102-240. December 18, 1991. Internet. September 2004. Available: [http://iti.acns.nwu.edu/clear/infr/istea\\_lst.html](http://iti.acns.nwu.edu/clear/infr/istea_lst.html).
4. U.S. Government. *Transportation Equity Act for the 21st Century*. Public Law 105-178. June 9, 1998. Internet. September 2004. Available: <http://www.fhwa.dot.gov/tea21/legis.htm>.
5. *Congestion Management Program Resource Handbook - Nov. 1990*. On-line. Internet. September 2004. Available: <http://ntl.bts.gov/DOCS/RHBK.html>.

6. Weiner, Edward. *Urban Transportation Planning in the United States: An Historical Overview - Revised and Expanded Edition*. Praeger Publishers, Westport CT. 1999. (Previous fifth edition, Washington, DC: U.S. Department of Transportation, Report DOT-T-93-02, Sept. 1997. On-line. Internet. September 2004. Available: <http://tmip.fhwa.dot.gov/clearinghouse/docs/utp/>).
7. Edwards, John D., Jr. (Editor). *Transportation Planning Handbook*. Second Edition. Washington, D.C.: Institute of Transportation Engineers, 1999.
8. Texas Transportation Institute. *Metropolitan Transportation Planning Issues: A Primer/Anthology for Small and Medium MPOs*. Washington, DC: U.S. Federal Highway Admin., Travel Model Improvement Program, April, 1999. On-line. Internet. September 2004. Available: <http://tmip.fhwa.dot.gov/clearinghouse/docs/general/sams/>.
9. Schoon, John G. *Transportation Systems and Service Policy*. New York: Chapman & Hall, International Thompson Publishing, 1996. 198 p.
10. American Association of State Highway and Transportation Officials (AASHTO). *A Policy on Geometric Design of Highways and Streets*. Washington, DC: 2001. 905 p.
11. Williams, K. Access Management Manual. TRB Committee Documents the State of the Art. *Transportation Research News*, no. 228, Sept.-Oct. 2003, p. 39-40. Washington DC: Transportation Research Board. On-line. Internet. September 2004. Available: [http://trb.org/publications/trnews/trnews228\\_p39-40.pdf](http://trb.org/publications/trnews/trnews228_p39-40.pdf).
12. Transportation Research Board. *Access Management Manual*. Washington DC: Transportation Research Board. 2003.
13. Homburger, Wolfgang S. et al. *Residential Street Design and Traffic Control*. Englewood Cliffs, NJ: Prentice-Hall, 1989. 152 p.
14. Appleyard, Donald. *Livable Streets*. Berkeley, CA: University of California Press, 1981. 364 p.
15. Bernick, M. and Cervero, R. *Transit Villages for the 21st Century*. New York: McGraw-Hill, 1997.
16. Cervero, R. et al. *Transit-Oriented Development in the United States: Experiences, Challenges, and Prospects*. Transit Cooperative Research Program Report 102. Washington DC: Transportation Research Board, 2004. On-line. Internet. Sep. 2004, 144 p. Available: [http://trb.org/news/blurb\\_detail.asp?id=4060](http://trb.org/news/blurb_detail.asp?id=4060).
17. California Department of Transportation. Guide to Transportation Benefit-Cost Analysis. Sacramento CA: Office of Transportation Economics. 2004. On-line. Internet. September 2004. Available: [http://www.dot.ca.gov/hq/tpp/offices/ote/Benefit\\_Cost/](http://www.dot.ca.gov/hq/tpp/offices/ote/Benefit_Cost/).
18. Transport Canada. *Guide to Benefit-Cost Analysis in Transport Canada*. Ottawa, Canada: Economic Evaluation Branch, Transport Canada, Report TP 11875E. September 1994. 99 p. & appendices. On-line. Internet. September 2004. Available: <http://www.tc.gc.ca/finance/bca/en/bca.pdf>.
19. Weisbrod, G. and B. Weisbrod. *Assessing the Economic Impact of Transportation Projects: How to Match the Appropriate Technique to Your Project*. Transportation Research Circular 477. Washington, D.C.: Transportation Research Board. 1997. On-line. Internet. September 2004. Available: [http://www.edrgroup.com/edr1/library/lib\\_guides\\_special/assessing-the-economic-im-2.shtml](http://www.edrgroup.com/edr1/library/lib_guides_special/assessing-the-economic-im-2.shtml).
20. Park, Chan S. *Contemporary Engineering Economics*. Third Edition. Englewood Cliffs, NJ: Prentice-Hall, 2002. 920 p.
21. American Association of State Highway and Transportation Officials (AASHTO). *A Manual of User Benefit Analysis for Highways*. Washington, DC: 2003. 296 p.

## A. General

"Traffic control devices shall be defined as all signs, signals, markings, and other devices used to regulate, warn, or guide traffic, placed on, over, or adjacent to a street, highway, pedestrian facility, or bikeway by authority of a public agency having jurisdiction" (Ref. 1). To be effective, a traffic control device should:

- 1 Fulfill a need.
- 2 Command attention.
- 3 Convey a clear, simple meaning.
- 4 Command respect from road users.
- 5 Give adequate time for proper response.

In addition, regulatory control devices must be sanctioned by state statute or local ordinance.

## B. Purposes

Traffic control devices normally provide visual information for the road users in order to:

- 1 **Regulate traffic.** So that users are:
  - a. Informed of speed limits, parking restrictions, one-way operation, no passing zones, load limits, turn prohibitions, road closures, restricted pedestrians crossings, etc.
  - b. Instructed to take required action – e.g., stop, yield, use a specific lane, keep to the right.
  - c. Informed of permitted maneuvers – e.g., turn left from two lanes, execute the maneuver indicated by green arrows.
- 2 **Warn road users.** So that users are:
  - a. Told about the presence of geometric features with potential hazards – e.g., curves, intersections, grades.
  - b. Informed of major changes in roadway character – e.g., road narrows, one-lane bridge, divided highway ends, pavement ends.
  - c. Told about obstructions or other physical hazards in or near the roadway – e.g., bump, dip, bridge abutments or piers, low clearances – or areas where hazards may exist under certain conditions – e.g., schools, slide areas, slippery pavement, railroad crossings.
  - d. Inform the motorist of regulatory controls ahead – e.g., signal, stop, or speed zone.
  - e. Advise the driver of appropriate action – e.g., safe speed, lateral placement, merging traffic.
- 3 **Advise road users.** Provide:
  - a. Route identification – e.g., markers (Interstate, U.S. , state, and local routes), city street signs, truck routes, detours.

- b. Directions – e.g., destination and distance signs, junction signs, interchange signing.
- c. Delineation of lane or roadway – e.g., painted lines, raised pavement markers, delineators, pavement edge markings.
- d. Traveler information – e.g., street names, rest areas, services, parking areas, scenic areas, first-aid locations, mileposts, stream names, elevations, landmarks.

## C. Uniformity

### 1 Types of Uniformity.

- a. *Uniform design* aids the road user in rapid recognition and comprehension. Control device design includes shape, color, size, symbol, wording, lettering, illumination, and reflectorization. Uniform design is gradually being achieved in the United States. Nonstandard devices may delay motorist reactions; they may also provide excuses for violations.
- b. *Uniform meaning* aids road user compliance with regulations. Most control devices have general uniformity of meaning, but local driver behavior and enforcement practices may modify this meaning. The yellow traffic signal indication and the colors of curb markings are two notable instances where uniformity of meaning has not been achieved nationally.
- c. *Uniform operation or application* promotes road user observance and avoids excessive or unwarranted use of control devices. It should ensure that similar conditions would be controlled by the same type of device. Unfortunately, some devices are installed under political or public pressure at locations where they are not warranted; such installations can lead to disrespect for traffic control devices.
- d. *Uniform placement* enhances the probability that a road user will clearly see a control device and correctly determine where the directed action is to take place; e.g., position to begin deceleration or to change lanes. When a uniform location cannot be achieved, the general rule is to install the device as near the standard location as possible while remaining in the normal line of vision.
- e. *Uniform maintenance* is necessary to ensure that legibility is retained during both day and nighttime conditions and that devices are removed or modified in response to changing needs.

### 2 Importance of Uniformity.

- a. *Government liability* has become an increasing concern to highway agencies. This is especially true in the case of traffic control devices, where an agency's failure to comply with accepted standards (such as those described in C.4.a) may be interpreted as negligence. Indeed, studies in Kentucky and Michigan (Ref. 2) found that alleged deficiencies in traffic controls accounted for the largest monetary share of the tort claims against their transportation departments. Compliance with uniform traffic control device design and use can significantly reduce the potential for successful tort claims.
- b. *Driving conditions*, such as high speeds, complex intersections and interchanges, high traffic volumes, and roadside distractions, require control devices that drivers can see, recognize, and understand quickly. By adhering to the principles of uniformity, the responsible highway agency will afford drivers the opportunity to make informed decisions and take appropriate actions in a safe and timely manner.
- c. *The design driver* for traffic control device usage should be the out-of-state or the unfamiliar motorist. The use of uniform devices with standard meanings improves the recognition time and helps ensure that both the local driver and the design driver have the same interpretation of the device's meaning.

### 3 Steps toward Uniformity.

- a. *Background.* Traffic control devices, initially in the form of guide signs pointing travelers toward destinations, have been around since the earliest roads. The Romans, for example,

employed milestones on their roads. In the U.S., a 1704 Maryland statute required trees alongside roads leading to a ferry, courthouse, or church to be marked with notches in defined patterns. (Ref. 3) In the first two decades of the twentieth century, traffic control signs (especially guide signs) along highways in the U.S. were erected by automobile clubs and trail associations, although any semblance of uniformity among routes was purely coincidental.

- b. *The Manual of Markers and Signs*, published by the Minnesota Highway Department in 1923, is probably the first state manual on the subject. Several of its provisions, including octagonal STOP signs and circular warning signs for railroad crossings, have continued to the present. The following year, the (then) American Association of State Highway Officials (AASHO) adopted most provisions of the Minnesota manual.
  - c. *AASHO's first traffic control device manual (Manual and Specifications for the Manufacture, Display and Erection of U. S. Standard Road Markers and Signs)* was issued in 1927.
  - d. *Separate urban and rural manuals* were published in 1930. In 1935, they were combined into a single publication, the forerunner of today's *Manual on Uniform Traffic Control Devices* (see C.4.a).
  - e. *Failure to achieve uniformity* of traffic control devices 70 years after the adoption of the first national set of standards attests to the difficulty of this task.
- 4 **Current National Traffic Control Device Standards.** Using authority provided by 23 U.S.C. §109(d) and §402(a), the FHWA Administrator is responsible for developing standards for traffic control devices. Regulations supporting this legislation are contained in 23 CFR 655.
- a. The *Manual on Uniform Traffic Control Devices (MUTCD)* (Ref. 1) is approved by the FHWA Administrator as the national standard for all traffic control devices installed on any street, highway, or bicycle trail open to public travel. The 2003 *MUTCD*, which provides guidelines for the design, application, and location of control devices, has ten parts:
    - I General provisions
    - II Traffic signs
    - III Markings
    - IV Traffic signals
    - V Low-volume rural roads
    - VI Work zones
    - VII Traffic controls for school areas
    - VIII Traffic control systems for highway-rail grade crossings
    - IX Traffic controls for bicycle facilities
    - X Highway-light rail transit (LRT) grade crossings
  - b. *Engineering studies* are required for the installation of most traffic control devices. *MUTCD* provisions and warrants may not substitute for engineering judgment. The decision to install or not install a device must recognize the conditions at a particular site. However, once a decision has been made to utilize a particular device, it must be designed, placed, and maintained in accord with the *MUTCD* guidelines.
  - c. *A National Committee on Uniform Traffic Control Devices*, representing state and local traffic engineers, offers guidance to FHWA on the *MUTCD*. Although it is an unfunded, informal advisory committee, the National Committee has the expertise to help FHWA respond to requests for interpretations, changes, or permission to experiment with traffic control devices.
  - d. *Testing is required* to determine the effectiveness of proposed new or alternate designs for traffic control devices. To assist with this task, FHWA has developed standard testing procedures and equipment to evaluate three factors essential to a device's effectiveness: conspicuity, comprehension, and recognition (Ref. 4).

- e. *Federal rule-making procedures* require FHWA to alert interested parties to revisions in the *MUTCD* by publishing the proposed changes in the *Federal Register* and soliciting comments.

## 5 Documents Related to Uniform Traffic Control Devices.

- a. *Traffic Control Devices Handbook (TCDH)* (Ref. 5) is a practical guide (not a standard) for implementing the requirements of the *MUTCD*. It provides background and concept explanations so that the end-user, from engineer to field crew, can comply with *MUTCD* provisions.
  - (1) The *TCDH* chapters parallels that of the *MUTCD*. However, within each section, the *TCDH* explains issues not covered in the *MUTCD*, such as the materials used for devices, positioning in the field, operation, and maintenance.
  - (2) For example, the *MUTCD* simply indicates that the TURN sign should be used when the safe speed is 50 km/h or less, whereas the CURVE sign should be used at higher speeds. The *TCDH* describes methods that field crews can use to determine safe curve speed.
- b. *The Uniform Vehicle Code (UVC)* (Ref. 6) presents a specimen set of Rules of the Road (applicable to road users) and regulations on traffic control uniformity (applicable to highway agencies). Regarding traffic control devices, the UVC mandates that:
  - (1) State transportation departments adopt a manual and specifications for a uniform system of traffic control devices. Prior to 2003, California published its own *Traffic Manual*, which was functionally very similar to the *MUTCD*. California has now adopted the *MUTCD*, and has published a supplement (Ref. 7) that incorporates special conditions.
  - (2) All governmental agencies within the state, as well as the owners of private property used by the public, conform to the standards specified in the state manual.
  - (3) Sale of nonconforming traffic control devices is prohibited.
  - (4) Installation of traffic control devices on or adjacent to streets and highways is restricted to responsible government agencies.

Of greatest importance to the traffic engineer, the UVC specifies the meaning of certain devices (traffic signal indications, STOP and YIELD signs), and requires driver, pedestrian, and cyclist compliance with official traffic control devices.

- c. The *Model Traffic Ordinance (MTO)* (part of Ref. 6) provides authority for a local traffic engineer to implement control schemes (such as one-way streets, parking control, placement of traffic control devices) that may not be covered in state codes.
- d. *Standard Highway Signs, 2004* (Ref. 8) is incorporated by reference in the *MUTCD*. This document provides detailed drawings of the signs in the *MUTCD*, and shows sign dimensions and letter heights for signs appropriate for bikeways, local streets, arterials, and expressways/freeways. It also contains detailed information on the alphabets used for signs and pavement legends.
- e. *Older drivers* constitute a growing share of the population. To address their traffic concerns, the new *MUTCD* (Ref. 1) adopted many recommendations from a recent report on mature motorist and pedestrian concerns (Ref. 9). For example, the *MUTCD* encourages redundant street name signs on the approaches to major intersections, increased sizes for signs (ONE-WAY, DO NOT ENTER) that restrict wrong-way movements, and application of retroreflective paint markings on the noses of median islands.

## REFERENCES

1. Federal Highway Administration. *Manual on Uniform Traffic Control Devices for Streets and Highways – 2003, Rev 1*. Washington, DC: 2004. <http://mutcd.fhwa.dot.gov/pdfs/2003r1/pdf-index.htm>.
2. Transportation Research Board. *Managing Highway Tort Liability*. National Cooperative Highway Research Program Synthesis 206, Washington, DC: 1994. 40 p.
3. Institute of Traffic Engineers. *Traffic Devices: Historical Aspects Thereof*. Washington, DC, 1971.
4. Pisano, P.A. "Developing a Standard Approach for Testing New Traffic Control Signs." *Public Roads*, Vol. 56, No. 1. FHWA, Washington, DC, 1992.
5. Institute of Transportation Engineers. *Traffic Control Devices Handbook*, Washington, DC: 2002.
6. National Committee on Uniform Traffic Laws and Ordinances. *Uniform Vehicle Code and Model Traffic Ordinance*. Alexandria, VA, 2002.
7. California Department of Transportation. *MUTCD 2003 California Supplement*. Sacramento, CA: 2004. <http://www.dot.ca.gov/hq/traffops/signtech/mutcdsupp/supplement.htm>.
8. Federal Highway Administration. *Standard Highway Signs, 2004*. [http://mutcd.fhwa.dot.gov/ser-shs\\_millennium.htm](http://mutcd.fhwa.dot.gov/ser-shs_millennium.htm).
9. Federal Highway Administration. *Older Driver Highway Design Handbook: Recommendations and Guidelines*. Washington, DC: 1998. FHWA-RD-99-045.





## A. Introduction

This chapter (as well as Chaps. 15 and 19) makes extensive reference to the *Manual on Uniform Traffic Control Devices (MUTCD, Ref. 1)*. In the U. S., the *MUTCD* is the national standard for traffic control devices on all roads open to public travel. However, most statements in the document are not standards per se. The *MUTCD* clearly defines four headings that are used consistently throughout to distinguish standards from recommendations.

- 1 **Standard.** A statement of required, mandatory, or specifically prohibitive practice regarding a traffic control device. The word "shall" is typically used.
- 2 **Guidance.** A statement of recommended, but not mandatory, practice in typical situations, with deviations allowed if engineering judgment or engineering study indicates the deviation to be appropriate. The word "should" is typically used.
- 3 **Option.** A statement of practice that is a permissive condition and carries no recommendation or mandate. The word "may" is typically used.
- 4 **Support.** An informational statement that does not convey any degree of mandate, recommendation, authorization, prohibition, or enforceable condition.

About half the state DOTs have published supplements or modifications to the *MUTCD*. Most make rather minor changes to the wording or add a sign that they regularly use; others, such as California (Ref. 2), make extensive additions, deletions, and revisions.

## B. Traffic Signs

- 1 **Definition.** A traffic sign is a device mounted on a fixed or portable support whereby a specific message is conveyed by means of words or symbols placed or erected for the purpose of regulating, warning, or guiding vehicular, pedestrian, or bicycle traffic.
- 2 **Sign Functions.** According to the *MUTCD*, "The functions of signs are to provide regulations, warnings, and information for road users."
  - a. Regulatory signs are used to inform road users of selected traffic laws or regulations and indicate the applicability of legal requirements. However, they are not required to confirm basic rules of the road.
  - b. Warning signs call attention to potentially hazardous conditions on or adjacent to a highway or street and to situations that may not be readily apparent.
  - c. Guide signs direct road users along streets and highways, inform them of intersecting routes, direct them to important destinations, and fulfill similar functions.

- 3 **Engineering Studies.** The *MUTCD* includes "warrants" for the installation of certain traffic signs. These warrants are not legal requirements of device installation; rather, they reflect the traffic engineering experience regarding situations under which particular signs are likely to prove beneficial. Before any sign is installed, however, appropriate traffic studies (e.g., volume, speed, accidents, roadside conditions, etc.) should generally be conducted; study results will be used by qualified engineers in their exercise of informed engineering judgment. Chaps. 5, 6, and 9, as well as Chap. 4 of Ref. 3, describe common study procedures related to signs.
- 4 **Sign Limitations.** Signs are easily damaged due to impact or vandalism. Over time, their visual quality will degrade due to dirt and normal reflectivity deterioration. An agency's decision to install a traffic sign is an implicit commitment to continually maintain the device.

### C. Sign Design

The *MUTCD* and the standard highway signs book (Ref. 4) establish uniform standards for sign design.

- 1 **Traffic Sign Codes.** To facilitate sign reference in text and design plans, the *MUTCD* assigns a code to each standard traffic sign. An expanded version of this code is used by field personnel to order specific signs. A typical code would be TS-ND-Z-Sp, where:

T = sign type: R for regulatory, W for warning, and several types for guide signs

S = sign series: if T = R, 1 for right-of-way series, 2 for speed limit, 3 for turn regulation.

N = sequential number within the series.

D = direction, if applicable: R or L for curve direction, direction of turn prohibition, lane reference.

Z = size: dimension (mm), width for most signs, edge for diamond and triangle signs.

Sp = speed, if applicable; for speed limit or advisory speed sign.

Using this notation, an R2-1-600-100 is 100 km/h speed limit sign with a width of 600 mm, and a W1-2R-750 is a right-hand curve sign with an edge dimension of 750 mm. Modifications of this sign code include information on distance (NEXT 1 KM), grade (%), or street name.

- 2 **Shape.** Certain shapes are reserved exclusively for certain types of signs (Fig. 14-1). Also, cross-bucks are used at railroad-highway grade crossings, and numerous shapes are used for route markers.
- 3 **Color.** Table 14-1 lists the color combinations specified by the *MUTCD* for traffic signs. Generally, red is confined to important regulatory signs, yellow to indicate warnings, orange for construction signs, green for route guidance, blue for motorist services, and brown for recreational and cultural information. Fluorescent yellow-green is used background color for school, pedestrian, and bicycle signs. A fluorescent pink background with a black legend is approved for incident management. Black and white are used extensively for sign legends, and white for background.
- 4 **Size.** The dimensions of signs should be based on the facility type and the speed of traffic. Standard sizes are given in Ref. 1. Ref. 4 provides detailed design information on a full range of sign sizes for bikeways through freeways. Large signs can be used for added emphasis or to ensure that they attract motorists' or bicyclists' attention.
- 5 **Message.** Standard sign designs recommended by Refs. 1 and 4 employ written and symbolic messages.
  - a. For written messages, three words are considered the desirable maximum on a regulatory or warning sign.
  - b. Symbolic representations can be recognized more easily. They may be pictograms or symbols.

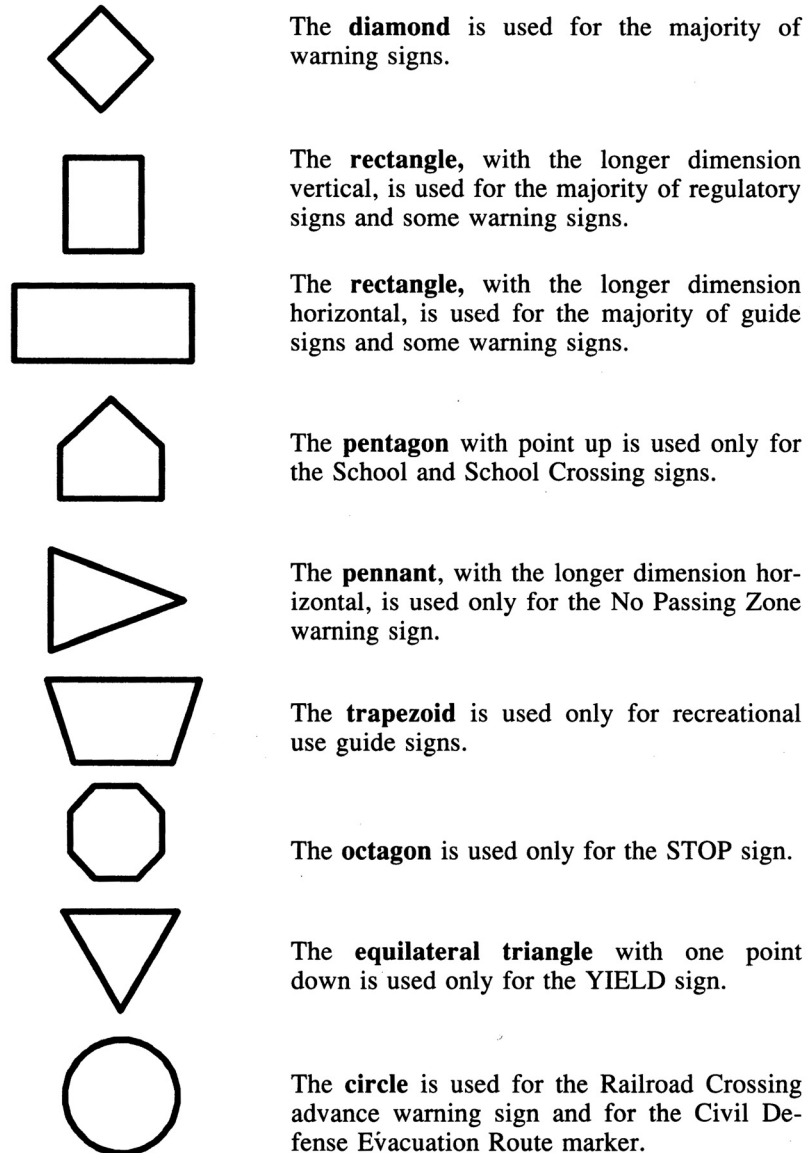

Source: Ref. 2.

**Fig. 14-1—Basic Shapes Used in Traffic Signs**

- 6 **Lettering.** Upper case letters are required on all regulatory and warning signs; guide signs may use initial capital letters followed by lower case letters. Ref. 4 recommends both letter height and "boldness" (the letter stroke width) for standard signs. Narrow (Series B and C) letters are recommended for parking signs; most warning signs use Series C or D letters and regulatory signs typically use Series D letters. The boldest (Series E) letters are needed for freeway guide signs.
- 7 **Illumination and Reflectorization.** Signs conveying warnings, important regulations, or essential directional information relevant at night must be illuminated or reflectorized (Ref. 1).
  - a. *Illumination* may be provided by means of:
    - (1) An external light source.
    - (2) A light within or behind the sign.
    - (3) Luminous tubing, fiber optics, patterns of incandescent light bulbs, or luminescent panels in the shape of the letter or symbol.

**Table 14-1—Color Combination for Traffic Signs**

Class	Background	Message	Application
Regulatory	Red	White	STOP signs and supplemental plates (e.g., 4-way), DO NOT ENTER, WRONG WAY signs
	Red/White	Red	YIELD signs
	White	Red	Parking prohibition signs
	White	Green	Permissive parking signs
	White	Red/Black	Prohibitory signs using symbols (red circle with diagonal slash)
	White	Green/Black	Permissive signs involving symbols (green circle)
	Black	White	Weigh station signs
	Black/White	Black	ONE WAY, preferential lane signs
	Blue	White	Disabled person's vehicle parking (California)
	White	Green/Blue	Disabled person's vehicle parking ( <i>MUTCD</i> )
	White	Black	All other regulatory signs
Warning	Yellow	Black	Warning signs except as shown below
	Orange	Black	Construction and maintenance zone signs
	Fluorescent Yellow/Green	Black	School, pedestrian, and bicycle signing
	Fluorescent Pink	Black	Incident Management
Guide	Blue	White	Information signs relating to motorist services
	Brown	White	Information signs relating to areas of recreational or cultural interest
	Green	White	Other guide signs (destination, street name)
	White/Blue	Black/White	Route markers

Source: Ref. 1.

- b. *Reflectorization* may be provided by reflective sheeting used as background or to form the symbol or word message legend. All colors other than black can be reflectorized. White is highly reflective; green and red are inherently lower. In order of increasing cost, reflectivity, and lifetime, reflectorized sheeting is available as Type I (engineering grade), Type II (super-engineering grade), Type III (high-performance bead), and Type IV (high-performance prismatic) (Ref. 5).
  - c. *Minimum sign reflectivity standards* have been proposed and evaluated by FHWA for more than a decade but are still not specified in numeric terms. Ref. 1 (Sec. 2A.09)
- 8 **Sign Borders.** Sign borders are the same color as the legend. This helps focus attention on the sign.
- 9 **Supplemental Beacons.** Where increased attention to the sign is necessary, a flashing beacon may be used. Yellow is used to supplement warning signs and selected regulatory signs; red may be used with a STOP sign. With the exception of school zone speed limit signs, the beacon shall not be within the border of the sign.

**D. Sign Location**

The standard placement for most signs is on the right-hand side of the roadway facing approaching traffic. Guide signs on wide streets or on high-speed facilities are often mounted overhead. Signs should be visible only to the traffic for which they are intended. The following principles should govern the longitudinal, transverse, and vertical placement of signs.

### 1 Longitudinal Placement.

- a. Regulatory signs are normally placed at or near the location where the regulation exists (e.g., stop, yield) or begins (e.g., wrong way, do not pass zone); additional signs may be used where a regulation (e.g., speed limit) continues over an extended section of highway.
- b. Warning signs are typically placed in advance of the hazard; exceptions to this include the chevron alignment sign, the no passing zone pennant, and the large two-headed arrow. The *MUTCD* suggests longitudinal placement of other warning signs as a function of the approaching traffic's speed, the safe speed at the hazard, and the expected action of drivers.
- c. Guide signs are often placed in advance of an intersection or junction; others, such as street name signs and kilometer posts, are located at the point where they apply.

### 2 Lateral Placement.

- a. Signs should be placed within the driver's cone of vision, but not so close that they constitute a hazard to an errant vehicle.
  - (1) On rural highways, ground-mounted signs should be placed at least 1.8 m beyond the edge of the shoulder or at least 3.7 m beyond the edge of the traveled way.
  - (2) On curbed streets in urban areas, signs should be installed with the nearest edge at least 0.3 m behind the face of the curb.
- b. Once the lateral sign position has been established, the sign face must be properly oriented; normally, signs are mounted at right angles to approaching traffic. However, the legibility of highly reflective signs within 6 m of the roadway may be improved if they are turned slightly (about 3%) away from the roadway. Signs placed beyond 9 m from the nearest travel lane should be angled toward the approaching traffic (see Ref. 5).

### 3 Vertical Placement.

- a. Most signs along rural highways are mounted at 1.5 m, measured vertically from the bottom of the sign to the near edge of pavement; supplementary signs, such as advisory speed plates, may be 0.3 m lower.
- b. Signs in urban areas or other locations where parking occurs should be mounted with a clearance of at least 2.1 m to the bottom of the sign.
- c. In California, signs viewed by the driver from a relatively short distance (e.g., DO NOT ENTER/WRONG WAY signs at freeway off-ramp terminals) may be mounted with the bottom 0.6 m above the pavement; this placement facilitates illumination by headlights.
- d. Overhead signs must have a minimum clearance over the entire roadway surface of at least 5.2 m to the bottom; the California standard (Ref. 2) is 5.5 m.

- 4 **Multiple Signs.** Two signs for different purposes should not ordinarily be mounted together; however, signs with non-conflicting messages, such as a street name on top of a STOP sign or a DO NOT ENTER on the back of an off-ramp STOP sign, may be mounted on the same support.

- 5 **Longitudinal Spacing.** Positive guidance principles require that messages be spread over time and distance, with preference normally given first to regulatory, then to warning, and finally to guidance messages. Within these categories, priority should be given to more critical upcoming elements (e.g., TURN or STOP AHEAD) rather than general warning (e.g., DEER CROSSING) or motorist information signs. Refs. 1 and 3 suggest that proper spacing between signs should be based on vehicle speeds.

## E. Sign Supports

In the past, large ground-mounted signs were often placed close to the roadway edge on substantial supports firmly embedded in the ground. Current guidelines (Ref. 6, Chap. 4) permit such rigid designs only if they are placed beyond the clear zone or behind protective barriers.

- 1 Most supports for small signs (panel area  $< 5 \text{ m}^2$ ) are now designed to break away or yield and bend. Common alternatives include:
  - a. Weakened wood posts designed to fracture readily and break away.
  - b. U-channel steel posts or standard steel pipe that bend on impact.
  - c. Metal square tubes with anchor sleeves; at impact, the posts fracture at the top of the sleeves.
- 2 Unless shielded by a barrier, large roadside signs (area  $> 5 \text{ m}^2$ ) typically have two breakaway supports, with a hinge at least 2.1 m above the ground and either a fracture coupler or a slip-base near ground level.

## F. Sign Application

Signs should only be installed where needed, as determined by adopted policies, engineering studies, or standard warrants (see Refs. 1 and 2), in conjunction with engineering judgment.

- 1 **Regulatory signs** inform drivers of certain laws and regulations, whose violation constitutes a misdemeanor or felony. Selected regulatory signs and their application are described here:
  - a. *STOP signs* require a complete stop at an intersection. Criteria for the application of these signs are discussed in Chap. 19.
    - (1) STOP signs should be located and oriented so that only the approach traffic that is to stop will see the face of the sign. This is especially important when the controlled approach intersects a through road at an acute angle. The STOP sign should normally be placed within 15 m of the intersecting street.
    - (2) Supplementary stop lines (in California, limit lines) may be placed on the pavement to indicate the actual location where the vehicle is to halt. These lines should always be used on paved roads if there might be any confusion about the proper stopping position. The word message STOP may also be painted on the pavement in advance of the stop line. California requires limit lines on all paved, side-street approaches to non-signalized state highway intersections (Ref. 3, Sec. 6-02.11).
    - (3) The *MUTCD* and the California Vehicle Code (§ 21355) prohibit the erection of STOP signs at entrances to intersections controlled by traffic signals.
  - b. *YIELD signs* provide an intermediate form of intersection control that requires a vehicle to stop only when necessary. Criteria for the application of these signs are discussed in Chap. 19. YIELD signs may be supplemented by the word YIELD painted on the pavement in advance of the sign.
  - c. *Speed limit signs* inform the motorist of existing speed regulations. Techniques for establishing speed zones are discussed in Chap. 22.
    - (1) Speed limit signs must be located at the beginning of each roadway section where a new limit begins.
    - (2) Additional signs should be installed within a zone where new drivers may enter from a crossroad or major driveway, or where it is necessary to remind drivers of the applicable limit.
    - (3) At the end of each roadway section a sign should be placed showing the succeeding limit. California frequently indicates that the previous speed has ended (e.g., END 50 SPEED LIMIT).
    - (4) REDUCED SPEED AHEAD or SPEED ZONE AHEAD signs should be used whenever approaching traffic is traveling 15 km/h or more above the speed limit of the section it is about to enter.
    - (5) Pavement markings indicating the regulatory speed may supplement the signs.
  - d. *Turn prohibition signs*, typically use a symbol message. They must be placed where a driver planning to make the prohibited turn can see them easily.

- (1) Signs prohibiting right turns are located on the near right corner. If signals are present, the sign may be placed adjacent to the signal face viewed by the motorists in the right lane.
  - (2) Signs prohibiting left turns, U-turns, or all turns are located on both the near right and far left corners or in the median. If signals are present, the sign may be placed adjacent to the signal face viewed by the affected motorists.
  - (3) For part-time restrictions, turn prohibition signs may be constructed using a changeable message sign face so that the restriction is only displayed during appropriate periods. A standard turn prohibition sign with a supplementary plaque (e.g., 7-9 am, MON-FRI) may be used, although motorist compliance will not be as good.
- e. *Lane-use control signs* are required by the *MUTCD* to be used in conjunction with lane control pavement markings.
- (1) Overhead signs mounted over the lanes to which they apply are preferred. Mandatory movement signs show an arrow and the written message "ONLY." Optional movement signs show arrows with the lower ends of their shafts superimposed to indicate the permissible movement. Overhead signs for reversible lane operation are illustrated in Chap. 24, Fig. 24-1.
  - (2) Curb-mounted signs for mandatory turns carry the message RIGHT LANE MUST TURN RIGHT (or the corresponding left turn message) and are located on the right (or left) of the intersection approach.
  - (3) Curb-mounted signs for double turns should carry, side by side on the same plate, two arrow symbols similar to the designs for the overhead signs. They should be mounted on the appropriate side an adequate distance from the intersection, so that drivers can select the proper lane.
- f. *Two-way left-turn signs* may be mounted overhead or along the roadway edge. Markings are required to create a two-way left-turn lane, so the signs are supplementary.
- g. *Preferential (diamond) lane signs* are used for lanes where usage is limited to certain types of vehicles (e.g., buses, taxis) or levels of occupancy (e.g., carpools).
- h. *DO NOT PASS and PASS WITH CARE signs* may be used to designate the limits of a legally enforceable no-passing zone. The signs are optional because the actual prohibition of passing must be designated with markings. The first sign can be supplemented on the left side by the pennant-shaped NO PASSING ZONE warning sign.
- i. *KEEP RIGHT signs* are used for two situations.
- (1) With a symbol or arrow at the approach end of medians, islands, and obstructions where traffic must keep to the right of the sign.
  - (2) On multilane highways where it is desirable for motorists to keep to the right except when passing indicated by SLOWER TRAFFIC KEEP RIGHT.
- j. *DO NOT ENTER signs* are placed at the end of a one-way roadway or ramp to prohibit traffic from entering the restricted section; standard placement is on the right-hand side of the road. WRONG WAY signs may supplement DO NOT ENTER signs on divided highways and freeway off-ramps; they are placed further from the crossroad than DO NOT ENTER signs.
- k. *ONE-WAY signs* must be used to designate streets on which vehicular traffic is allowed to travel in one direction only.
- (1) According to Ref. 1, ONE-WAY signs must be located on the near right and far left corners of the intersection facing traffic entering or crossing the one-way street. At signalized intersections, they may be placed near the appropriate signal faces. California policy is to place a single sign at the appropriate far corner for the wrong-way turn.
  - (2) Signs should also be placed along one-way streets directly opposite the exits from alleys and other public ways.



- l. *TWO-WAY TRAFFIC AHEAD* signs should be placed on both sides of a one-way street at an appropriate distance, depending on approach speeds and type of facility, from the intersection where two-way traffic is resumed. California (Ref. 3) classifies this sign in a word format (R40) as regulatory. The *MUTCD* symbol message (W6-3) for two-way traffic is a warning sign that is placed at points along a street or highway where motorists might erroneously assume that they will continue on a one-way roadway.
  - m. *Parking signs* should contain the appropriate message and be installed at sufficient locations to adequately inform the motorist of the applicable regulations. Parking prohibition signs use red letters on a white background; signs that permit parking (e.g., ONE HOUR PARKING) have green letters on a white background.
  - n. *Other regulatory signs* are self-explanatory and should be installed at appropriate locations. These signs include, for example, ROAD CLOSED, NO DUMPING ALLOWED, COMMERCIAL VEHICLES PROHIBITED, NO HITCHHIKING, and truck load limit signs.
- 2 **Warning signs** inform drivers of existing or potentially hazardous conditions and may call for a reduction in speed or other maneuver.
- a. *General principles:*
    - (1) Their usage should be kept to a minimum because overuse leads to disrespect for other warning signs.
    - (2) Nonspecific messages, such as SLOW or CAUTION, must be avoided. Instead, the sign should alert the motorist to the specific hazard and perhaps the proper speed.
    - (3) Warning signs that alert motorists to physical features (e.g., CURVE, NARROW BRIDGE, PAVEMENT ENDS) are readily verified, thus instilling a spirit of confidence that the message is correct. By contrast, messages that warn of intermittent conditions (e.g., DEER CROSSING, ICY ROAD, GUSTY WINDS) often require independent corroboration to be credible.
    - (4) Few warning signs are actually required by the *MUTCD*; most installations are at the discretion of the engineer, based on studies and informed judgment. Exceptions include:
      - (a) STOP AHEAD sign, which are required in advance of intersections where the STOP sign is not visible sufficiently in advance of the intersection to allow the road user to properly respond; the same applies to YIELD signs and signals.
      - (b) The railroad advance warning sign, which must (with minor exceptions) be used in advance of all rail-highway grade crossings.
  - b. *Typical conditions or hazards* that may be improved through the proper use of warning signs include:
    - (1) Locations where speed should be reduced, such as curves, grades, bumps, dips, and approaches to STOP and YIELD signs, to signals, and to rail-highway grade crossings. When possible, the application of a consistent design speed over an extended section of highway reduces the need for warning of alignment conditions.
    - (2) Locations where lateral placement may have to be modified or constrained, such as narrow roadways, beginnings and ends of medians, channelizing islands, reduction in the number of lanes, merging traffic, and no-passing zones.
    - (3) Approaches to potential conflict zones, such as intersections, merging areas, pedestrian and bicycle crossings, and school zones.
    - (4) Miscellaneous conditions, such as dead-end streets, restricted clearances, and areas frequented by wild animals or subject to rock falls, icing, or flooding.
    - (5) The special traffic control requirements in highway work zones are discussed in Chap. 26.

- c. *Longitudinal location* of warning signs depends on the nature of the hazard, the expected driver reaction (e.g., braking or lane change), and the speed of traffic. *MUTCD* Table 2C-3 recommends a range of advance placement distances, for example:
    - (1) Ahead of a stop condition, warning signs should be placed from 30 m in advance where posted speeds are 60 km/h, up to 170 m where speeds are 110 km/h.
    - (2) In more complex situations (e.g., RIGHT LANE ENDS, which could require a lane change), the minimum recommended distances range from 110 m at 60 km/h to 260 m at 110 km/h.
  - d. *Advisory speed plates*, which are black and yellow squares with the message "XX M.P.H.", can supplement standard warning signs when the safe speed is less than the regulatory limit. The appropriate safe speeds may be determined through field studies (e.g., Chap. 6, sec. H).
- 3 **Guide signs** provide motorists with information about their location and route, direct them to various destinations, identify roadside and adjacent motorists' services and points of interest, and furnish other guidance information. The four major types and their recommended locations are:
- a. *Route markers* should be located at all major intersections, at intervals along the highway to reassure the motorist, and at locations along urban arterials leading to a numbered route.
  - b. *Destination signs* should be placed far enough ahead of intersections and interchanges to allow adequate time for drivers to make their routing decisions. Distance signs are located beyond major intersections, and at intervals of 15-25 km.
  - c. *Information signs* should be located in advance of the point of interest where a motorist may want to stop, including rest areas, scenic views, or recreation areas (see also F.4.g).
  - d. *Street name signs* should be installed at all intersections, even in rural areas. Many agencies use oversize street name signs on arterials; the *MUTCD* endorses the concept of placing advance street name signs prior to major cross streets to facilitate proper maneuvers, especially by elderly (Ref. 7) and unfamiliar drivers, as they approach the intersection.
- 4 **Directional Signing on High-Speed Highways.** High traffic speeds and the complex interchanges found on modern freeways present a special directional signing problem. Control devices must guide motorists to the correct lane or off-ramp, and must begin this guidance sufficiently early to minimize last-minute lane changes. Directional signing may be accomplished by:
- a. *Place names*, with or without the distance to these places.
  - b. *Signed route numbers.* The *MUTCD* now requires that all numbered routes be identified with signs.
  - c. *Highway names*, such as Beltway or El Camino Real, are used if the name is in general usage. Highways should not be named after one of their terminals, e.g., Santa Ana Freeway, because this confuses motorists traveling away from the named terminal.
  - d. *Cross-street names* are required in larger cities to inform motorists of their approximate location. Freeways rarely provide clearly distinguishable landmarks adjacent to the roadway.
  - e. *Numbered interchanges.* The *MUTCD* requires the numbering of interchanges on freeways, and recommends kilometer (mile) post numbering rather than consecutive numbering.
  - f. *Kilometer (mile) posts* must be placed on all freeways (Ref. 1). Numbering begins at the state's south or west border, or at the south or west beginning of the route. Some states restart numbering at each county line.
  - g. *Motorist service signs* provide directions to food, fuel, lodging, hospitals, telephones, and similar services. This type of guidance is essential in advance of freeway exits because the businesses themselves may not be visible from the roadway.

- 5 **Low-Volume Rural Roads.** Part 5 of the *MUTCD* attempts to address the special issue of traffic signs and markings for low-volume roads, which are defined as roads with an average daily traffic (ADT) of less than 200 and are not on a state highway system. Smaller sign sizes are permitted, and selected requirements and recommendations for sign usage are relaxed on these facilities. On unimproved roads, the NO TRAFFIC SIGNS warning sign may be used to advise motorists that no signs are installed on the road ahead.

## G. Traffic Markings

- 1 **Definition.** Traffic markings are generally defined as all lines, patterns, symbols, words, colors, or other devices set into the surface of, applied upon, or attached to the pavement or curbing and placed for the purpose of regulating, warning, or guiding traffic.
- 2 **Marking Functions.** Markings may supplement other traffic control devices or they may be used alone to convey information that would be difficult to convey using other devices. Specifically markings are used to:
- Display regulations (e.g., no-passing zones, curb parking restrictions).
  - Supplement other devices (e.g., STOP bars, symbol arrows).
  - Guide traffic (e.g., lane lines, route number.)
  - Warn traffic (e.g., SIGNAL AHEAD, rail-highway crossing legend).
- 3 **Marking Limitations.** Although traffic markings can accomplish objectives that signs cannot, they have several important limitations:
- Pavement markings* may be hidden by other vehicles or by snow or dirt. They may not be readily visible when wet. They wear due to traffic and the environment, and must be maintained or replaced.
  - Raised markers* are less prone to obliteration and are more visible in rain, but may be dislodged by traffic or snow plows.
  - Post-mounted delineators* may become coated by dust and grime, losing some of their target value, and may be knocked down.
  - Removal of markings* from the pavement is a difficult task. Marking installation should be carefully planned and implemented to avoid the need for post-installation changes.

## H. Marking Design

The standards and recommendations contained in the *MUTCD* provide a basis for achieving uniformity of markings, especially lane, centerline, and curb markings. Figs. 3B-1 to 3B-31 of Ref. 1 show typical examples of many pavement marking applications.

- 1 **Materials.** All markings that apply at night must be reflectorized.
- Paint* is the most common material for marking pavements and curbs, but other materials (e.g., thermoplastic and cold plastic) are also suitable. Materials must provide the specified color and reflectivity throughout their useful life. Reflectivity in painted markings is achieved by mixing small glass beads with the paint.
  - Raised pavement markers*, 10-25 mm high, may be used for pavement marking purposes where snow removal is not a major problem. They are normally separated by spaces, a variation in pattern being used to simulate solid and broken lines.
  - Rumble strips* are raised or grooved patterns installed on the pavement surface of a travel lane or a shoulder. Raised strips, typically 15 mm high, may be created on existing pavements with tar or asphalt. Grooves may be placed when a roadway is resurfaced, but milling them into the road or shoulder surface has become more common. These devices provide motorists with audible and tactile warning that their vehicles are approaching a

critical decision point (e.g., an intersection, toll plaza, horizontal curve, lane drop, or work zone) or are encroaching onto the shoulder. Studies suggest that rumble strips on STOP-controlled intersection approaches may reduce selected crash types by 50%; those on shoulders may reduce run-off-the-road accidents by 30% or more (Ref. 8).

d. *Delineators* are small reflective units mounted on flexible metal supports.

Marking material used near pedestrian or bicycle activity should not present hazards of tripping or slipping to pedestrians or two-wheel vehicle users.

2 **Colors.** White, yellow, red, and blue are the primary marking colors. In addition, black may be used in combination with white or yellow to enhance contrast with a light-colored pavement, particularly Portland Cement Concrete (Ref. 5). Blue raised pavement markers may be used to indicate fire hydrant locations.

3 **Longitudinal Markings** (parallel to the roadway):

a. *Basic Concepts.*

- (1) Yellow lines separate traffic flows in opposing directions, separate two-way left-turn lanes and reversible lanes, and mark the left roadway edge on divided highways.
- (2) White lines delineate the separation of traffic flows in the same direction or mark the right edge of a roadway.
- (3) Red raised markers are applied to one-way roadways to indicate to drivers viewing them that they shall not enter or use the roadway.
- (4) Broken lines are permissive in character.
- (5) Dotted lines provide path guidance.
- (6) Solid lines are restrictive in character.
- (7) Width of line indicates the degree of emphasis.
- (8) Double lines indicate the maximum restriction.
- (9) Markings that must be visible at night shall be reflectorized unless ambient illumination ensures adequate visibility.

b. *Dimensions.*

- (1) *Width.* The *MUTCD* recommends 100–150 mm for the "normal" width, and at least twice this range for "wide" longitudinal stripes.
- (2) *Broken Lines.* The *MUTCD* recommends a ratio of 1:3 for length of a stripe to a gap. On rural highways, a recommended standard is 3-m stripes separated by 9-m gaps. California uses 3.6-m stripe and a 10.8-m gap, with a raised marker in the middle of the gap on high-speed roadways.
- (3) *Dotted Lines.* Dotted lines through intersections are formed by stripes 0.6 m in length separated by gaps at least 1.2 m long. When dotted lines are used on freeways, the stripes are 0.9 m long and gaps are 3.6 m.

4 **Transverse Markings.** Transverse markings include STOP bars (called limit lines in some states), crosswalk lines, railroad crossing markings, and diagonal lines used in painted channelization. Most transverse markings are white; however, California requires the use of yellow lines in the vicinity of schools.

Because of the low approach angle at which transverse markings are viewed, they must be proportioned to provide visibility commensurate with that of longitudinal lines. California uses 300-mm stripes for transverse markings; however, transverse bars in the railroad crossing advance markings are twice this width. The *MUTCD* permits transverse markings up to 600 mm wide.

a. *STOP bars* extend across all approach lanes; they are normally 300 to 600 mm in width and placed 1.2 m in advance of the nearest crosswalk line.

- b. *Crosswalk markings* may require stripes of extra width (up to 600 mm) where vehicle speeds are high, where a crosswalk is unexpected (e.g., midblock), or where there is no STOP bar. Minimum width of crosswalks should be 1.8 m. Some jurisdictions use "Zebra" striping to enhance visibility, but the extra painted surface may create a hazard for two-wheeled vehicles. As discussed in Chap. 20, crosswalks exist at intersections, whether they are marked or not.
  - c. *Railroad crossing advance markings* consist of an X, the letters RR, and a pair of transverse lines; on two-lane roads, no-passing markings are also included.
  - d. *Diagonal crosshatching* augments painted channelization islands or shoulders in locations where special visibility problems may exist. This technique is often employed at areas immediately in front of obstructions in the center of streets or undivided highways, and on shoulders near freeway off-ramps where driving is prohibited.
- 5 **Parking Space Markings.** Parking space markings are 100-150 mm wide. Spacing is discussed in Chap. 23. Blue and white markings are used to designate parking spaces for the disabled.
- 6 **Word Markings.** Word and symbol pavement markings for mandatory messages should only be used in support of standard signs. They should be limited to as few words as possible, but never more than three.
- a. Markings are usually white, but California school crossing messages must be yellow.
  - b. Letters and symbols must be elongated to facilitate recognition from the driver's perspective. For most applications, letters should be at least 2.4 m high, although 1.8-m characters may be used where speeds are low. The space between words should be at least four times the letter height. The markings section of Ref. 4 provides proper dimensions for letters and symbols.
  - c. Multiple line messages should read "up" as viewed by the approaching driver;

<b>AHEAD</b>	<b>XING</b>	<b>STOP</b>	<b>PED</b>
e.g.,		not	
<b>STOP</b>	<b>PED</b>	<b>AHEAD</b>	<b>XING</b>

- 7 **Post-Mounted Markers.** Post-mounted markers are reflectorized either by reflective sheeting or through the use of reflector elements 75 mm in diameter (Refs. 1 and 2).
- a. *Object Markers.* The MUTCD specifies three types of object markers:
    - (1) Type 1 consists of either nine yellow 75-mm reflectors mounted symmetrically on a yellow or black 450-mm square diamond panel, or an all-yellow panel of reflective sheeting. Like other markers, this device may be larger if conditions warrant.
    - (2) Type 2 consists of either three 75-mm yellow reflectors arranged horizontally or vertically on a 100 x 375-mm white target plate, or an all-yellow 150 x 300-mm reflective panel.
    - (3) Type 3 consists of a 300 x 900-mm vertical rectangle with alternating black and yellow stripes sloping downward at a 45% angle toward the side of the obstruction on which traffic is to pass.
    - (4) California Type R is a 600 x 750-mm vertical rectangle with alternating black and reflectorized-yellow stripes sloping downward at an angle of 45% toward each side of the sign (Ref. 3). Traffic may pass on either side of this marker and the object behind it.

Although circumstances may make other heights appropriate, these devices should generally be mounted with the bottom at least 600 mm above the roadway.
  - b. *Delineators* are similar to Type 2 object markers except they contain one or two 75-mm reflective units, white for the right roadside and yellow for the median. They may be post mounted 1.2 m above the roadway, 0.6 to 2.4 m outside the shoulder edge.
  - c. *End of Roadway Markers* have the same dimensions as the Type 1 object marker; the reflective units are red and are mounted on a red or black panel.

## I. Marking Applications

### 1 Pavement markings.

a. *Centerlines* are required by the *MUTCD* on paved two-way streets or highways under the following conditions:

- (1) On urban arterials and collectors with a roadway width of  $\geq 6.1$  m and an ADT  $> 5000$ .
- (2) On all two-way roadways with three or more lanes.

Centerlines should be placed on urban arterials and collectors over 6.1 m wide with an ADT greater than 4,000, and on rural arterials and collectors over 5.5 m wide with an ADT exceeding 3,000. Centerlines may also be placed at other locations where an engineering study indicates a need for them. This includes areas where passing is prohibited.

b. *No passing zones* are established based upon prevailing speed and minimum sight distance necessary to pass safely.

- (1) Vertical curve sight distance is the distance at which an object 1,070 mm above the pavement can just be seen from another point also 1,070 mm above the pavement.
- (2) Horizontal curve sight distance is measured between centerline points along a line tangent to the sight obstruction (e.g., an embankment, vegetation, building).
- (3) A curve warrants a marked no-passing zone when the minimum sight distance is less than the distance listed in Table 14-2. Because they are based on different assumptions, passing sight distances for the design of new roadways are about twice the values given in this table.
- (4) According to Ref. 3, the minimum No Passing Zone length must be at least 50% of the passing sight distance.
- (5) No Passing Zones may be marked on intersection and rail-highway grade crossing approaches; they are typically placed for a distance of 30 to 90 m.

**Table 14-2—Minimum Sight Distance for Safe Passing**

85th Percentile Speed	Minimum Sight Distance	85th Percentile Speed	Minimum Sight Distance
50 km/h	160 m	90 km/h	280 m
60	180	100	320
70	210	110	355
80	245	120	395

Source: Ref. 1.

c. *Yellow longitudinal lines* are also used to delineate reversible lanes (with a pair of broken lines) and two-way left turn lanes (with a broken line on the inside and a solid line toward the adjacent traffic lane).

d. *Lane lines* are helpful in guiding traffic and in achieving efficient utilization of the roadway. They are normally broken white lines, but solid or double solid lines may be used to discourage or prohibit lane changes. They are required on Interstate highways; they should also be used:

- (1) On all roadways with two or more adjacent lanes in the same travel direction.
- (2) At congested locations where the roadway will accommodate additional lanes.

e. *Marking extensions through intersections* may be desirable to guide vehicles through a complex area, such as intersections with double left-turn lanes. Dotted lines may be used for this purpose. A solid line should be used where a greater degree of restriction is required.

- f. *Pavement-width transition markings* should be used whenever the number of lanes decreases. The transition is accomplished using a taper with a length given by the following equations:

$$\begin{array}{ll} \text{For speeds } \geq 70 \text{ km/h:} & L = 0.62 WS \\ \text{For speeds } < 70 \text{ km/h:} & L = WS^2/155 \end{array}$$

where  $L$  is the taper length (m),  $S$  is the off-peak 85th percentile speed (km/h), and  $W$  is the offset distance (m).

- g. *Pavement edge lines* are required by the *MUTCD* on all freeways and expressways, and on all paved rural arterials with a roadway width exceeding 6.1 m with an ADT of at least 6,000; they are recommended for other classes of roads as a visual guide for drivers. Pavement edge lines on the right side of the road are white, and those on the median side are yellow. Edge lines are continued across driveways but are broken at intersections.
- h. *Stop lines* should be used when it is desirable to indicate where drivers are supposed to stop in obedience to a STOP sign or traffic signal. The word STOP may be marked on the pavement in advance of the stop line at a stop-controlled intersection. Yield Ahead triangle pavement markings, shown in Ref. 1 Fig. 3B-25, are used to designate the point where approaching motorists must yield.
- i. *Word messages* should be used wherever it is desirable to supplement signs, indicate maneuvers, or provide advance warning. They may be installed at locations where traffic controls are new or altered, even though the word message markings are not to be maintained.
- j. *Speed hump markings*, white chevrons in the direction of travel, are in Fig. 3B.29 of Ref. 1.
- k. *Crosswalks*. See Chap. 20.
- 2 **Curb Markings.** Curb markings may indicate parking prohibitions or other restrictions (e.g., a bus zone) along the curb, or simply delineate the curbs of medians and other islands.
- a. *The MUTCD* specifies yellow, white, and red for curb markings; it does not, however, assign specific meanings to these curb colors. It recommends the use of standard regulatory signs to explain the marking's meaning; if signs are not used, the regulation (e.g., No Parking) should be stenciled on the curb. Local authorities are permitted to prescribe special colors.
- b. *California* prescribes the following color codes:
- (1) Red – parking, stopping, or standing prohibited (except buses at bus stops).
  - (2) Yellow – commercial loading zones, often in effect only during business hours.
  - (3) White – passenger loading zones.
  - (4) Green – short parking time limits, usually 30 minutes or less.
  - (5) Blue – parking limited to vehicles of disabled persons.
- 3 **Post-Mounted Markers.** Post-mounted markers are used to alert drivers to physical restrictions and obstructions in or near the roadway, to unusual alignment situations, and other hazards, especially at night or under other conditions of poor visibility.
- a. *Type I Object markers* are placed in front of or attached to obstructions in the roadway, such as bridge columns and signs at the beginning of medians or channelizing islands.
- b. *Type II Object markers* are intended to delineate the location of noses of median islands and islands forming right-turn lanes, gore noses at freeway off-ramps, and similar locations.
- c. *Type III Object markers*, which consist of alternating black and yellow 75 mm stripes pointing downward at a 45° angle, are installed in front of restrictions or obstructions to the width of the traveled way, such as bridge abutments or overpass piers.
- d. *Delineators* are used to define the roadway alignment along the outside edge of curves, at approaches to intersections, at median openings, along the outside edge of freeway ramps and speed change lanes, and in advance of clearance markers. They may also be needed on highway sections with inadequate shoulder widths and in snow areas.

## REFERENCES

1. Federal Highway Administration. *Manual on Uniform Traffic Control Devices for Streets and Highways – 2003*, Rev 1. Washington, DC: 2004. <http://mutcd.fhwa.dot.gov/pdfs/2003r1/pdf-index.htm>.
2. California Department of Transportation. *MUTCD 2003 California Supplement*. Sacramento, CA: 2004. <http://www.dot.ca.gov/hq/traffops/signtech/mutcdsupp/supplement.htm>.
3. Institute of Transportation Engineers. *Traffic Signing Handbook*. Washington, DC: 1997.
4. Federal Highway Administration. *Standard Highway Signs, 2004*. [http://mutcd.fhwa.dot.gov/ser-shs\\_millennium.htm](http://mutcd.fhwa.dot.gov/ser-shs_millennium.htm).
5. Institute of Transportation Engineers. *Traffic Control Devices Handbook*. Washington, DC: 2001.
6. American Association of State Highway and Transportation Officials. *Roadside Design Guide*. Washington, DC: 2002.
7. Federal Highway Administration. *Older Driver Highway Design Handbook: Recommendations and Guidelines*. Washington, DC: 1998. FHWA-RD-99-045.
8. Harwood, D.W. *Use of Rumble Strips to Enhance Safety*. Washington, DC: Transportation Research Board, NCHRP Synthesis 191, 1993.





### A. General

Traffic signals may be defined as power-operated signal displays used to regulate or warn traffic. In a broad sense, traffic signals include displays for intersection control, flashing beacons, lane-directional signals, ramp metering signals, pedestrian signals, railroad crossing signals, and similar devices. This chapter emphasizes intersection controls.

- 1 **History.** Modern traffic signals developed from manually operated semaphores that were first used in 1868 in London. In 1913, James Hoge invented the first electric traffic signal to be actually used (Cleveland in 1914). This device appears to be the origin of the 3-color signal that spread across the country in the early 1920s. Interconnected signals were first used in Salt Lake City in 1917. A progressive system was first proposed in 1922. The first actuated signals were installed at New Haven, East Norwalk, and Baltimore in 1928.
- 2 **Value of Traffic Signals.** When installed in accordance with the warrants listed in Chap. 19 and properly operated, traffic signals can provide specific advantages in traffic control and safety. Signal installations, however, also have certain disadvantages that may or may not apply at a particular location. Ref. 1 includes useful guidelines for the analysis and design of traffic signals.
  - a. Advantages of signal installations.
    - (1) Provide for the orderly movement of traffic.
    - (2) Reduce the frequency of certain types of accidents (i.e., right-angle and pedestrian).
    - (3) Increase the traffic handling capacity of the intersection.
    - (4) Provide a means of interrupting heavy traffic to allow other traffic, both vehicular and pedestrian, to enter or cross.
    - (5) Provide for nearly continuous movement of traffic at a desired speed along a given route by coordination.
    - (6) Promote driver confidence by assigning right of way.
  - b. Disadvantages of signal installations.
    - (1) Most installations increase total intersection delay and fuel consumption, especially during off-peak periods.
    - (2) Probable increase in certain types of accidents (e.g., rear-end collisions).
    - (3) When improperly located, signals cause unnecessary delay and promote disrespect for this type of control.
    - (4) When improperly timed, signals cause excessive delay, increasing driver frustration.

### 3 Definitions.

- a. *Traffic Signal.* A complete installation including items such as signal heads, wiring, and control mechanisms.
- b. *Controller Assembly.* A complete electrical mechanism mounted in a cabinet for carrying out the operation of a traffic control signal (Ref. 2).
  - (1) *Pretimed.* With predetermined fixed cycle length(s), fixed interval duration(s), and interval sequences.
  - (2) *Traffic-Actuated.* Operates in response to varying demands of traffic as registered by the controller detectors (Ref. 2).
- c. *Controller Unit.* That portion of a controller assembly that is devoted to the selection and timing of signal displays (Ref. 2).
- d. *Beacon.* A signal face, either yellow or red, that flashes to indicate to motorists that they are to proceed with caution or stop.
- e. *Signal Head.* The assembly containing the signal faces.
- f. *Signal Face.* That portion of a signal head that provides the indications to control one or more traffic movements in a single direction. (See Sec. B. below.)
- g. *Signal Indication.* The illumination of a signal lens (or an equivalent device).
- h. *Cycle.* The total time to complete one sequence of signalization around an intersection (Ref. 2).
- i. *Interval.* The part or parts of the signal cycle during which signal indications do not change (Ref. 2).
- j. *Traffic Phase.* The green, change, and clearance intervals in a cycle assigned to any independent movement(s) of traffic (Ref. 2).

### B. Signal Faces

The signal face contains the lenses that convey a message to the roadway users and pedestrians.

- 1 **Vehicular Indications.** Vehicular lenses are round, either 200 or 300 mm in diameter. They may be stacked vertically or horizontally, or arranged in a box-like configuration. Fig. 4D-3 of Ref. 3 shows the typical arrangements of lenses in signal faces. Faces are furnished with visors and, on occasion, backplates to optimize visibility. For through traffic, a minimum of two faces for each approach are required. Single turn lanes operating on a separate phase may be controlled by a single face, although two faces are normally desirable.

Recent legislation requires that all signal lamps manufactured after January 1, 2006 meet new EPA Energy Star guidelines. As of early 2006, only LED lamps meet these requirements. Although current installations do not need to be replaced, new indications will need to be LED. This also applies to lane signal lenses (B.2.) and pedestrian indications (B.3.).

- a. *Circular Lenses.* These lenses are used to control vehicular traffic on an approach without separate timing for turning vehicles.
- b. *Arrow Lenses.* Arrows are used to control turning vehicles where special timing exists. Combinations of arrow lenses (green, yellow, red) may be used for different phasing design. Some jurisdictions have not yet adopted the use of red arrows. Occasionally, upward pointing green arrows are used over through lanes to provide additional lane direction. Also, arrow lenses are sometimes used at intersections when all approaching traffic must turn, i.e., T-intersections.
- c. *Fiber Optic Arrows.* This type of display has two light sources, one with a green and one with a yellow filter. Using fiber optic techniques, either a green or a yellow arrow is displayed. This type of lens may not meet the Energy Star standards and, therefore, may have to eventually be replaced with LED lenses or other lamps meeting these standards.

- d. *Optically Programmable Lenses.* This type of signal lens has very sharply defined visibility areas and can be aimed in such a way that only drivers or pedestrians in certain locations can see the illuminated display. These heads are used in locations where signal viewing could be confusing, as at closely-spaced intersections (e.g., at the street intersections of diamond interchanges) and at offset and skewed intersections. Additionally, these heads are being used for Dallas-type phasing for left-turning traffic.

New signal indications needing to restrict visibility will have to use traffic signal lamps meeting EPA Energy Star guidelines. Louvers installed on the signal visor can restrict the visible areas while meeting the new guidelines.

- 2 **Lane-use Control Signals.** These devices are a positive form of lane control for reversible lanes (see Chap. 24, Sec. B. for discussion on applications). Standards for such signals are set forth in the *MUTCD* (Ref. 3, Sec. 4J.03 to 4J.04).

The lane-use control signal has one face per lane for each direction of traffic flow. Each face controlling a lane whose flow may be reversed incorporates two or three distinctive rectangular signal units, typically 450 mm square, whose indications are clearly visible for 700 m. Lane control signals 300 mm square are allowed in areas of minimal visual clutter and speeds of less than 70 km/h. Faces should be spaced longitudinally so that at least one, preferably two, is visible to drivers at any time. The indications and their meanings are:

- a. *Downward-pointing green arrow.* Drivers are permitted to drive in the lane under the arrow. They must obey all other traffic controls present and follow normal safe driving practices.
- b. *Yellow X symbol (if used).* Drivers are warned that a control change is imminent and that a red X will follow. They should vacate the lane in a safe manner.
- c. *Red X symbol.* Drivers are prohibited from driving in the lane over which this symbol is displayed; this indication accordingly modifies the meaning of all other traffic controls present.
- d. *White one-way/two-way left turn arrow.* Drivers are permitted to use the lane under the signal as either a one-way or a two-way left-turn lane.

- 3 **Pedestrian Signals.** Faces for pedestrian indications consist of rectangular lenses. All new installations (since 1982) use symbols to denote periods of "walk" and "don't walk". Displays indicating the number of seconds remaining in the pedestrian change interval can also be used. Animated eye symbols can be used to alert pedestrians to watch for turning traffic.

## C. Pretimed Signals

This common type of traffic control signal assigns the right of way at an intersection according to a predetermined schedule based on historic traffic patterns. The time interval for each signal indication in the cycle is of fixed length.

### 1 Advantages of Pretimed Signals.

- a. Can be coordinated to provide continuous flow of traffic at a given speed along a particular route, thus providing positive speed control.
- b. Can be easily adjusted in the field.
- c. Under certain conditions can be programmed to handle peak demand patterns.

### 2 Disadvantages of Pretimed Signals.

- a. Cannot recognize or accommodate short-term fluctuations in traffic demand.
- b. Can cause excessive delay to vehicles and pedestrians during off-peak periods.

### 3 Controller Units.

- a. *Synchronous.* Timing is synchronized by power source frequency, enabling other signal installations fed by the same power source to be coordinated. Cycle length is established by a series of gears and can be set at 5-s intervals within the range of the controller unit.

- b. *Solid-State*. These are essentially digital counters, counting the 60-cycle line frequency transmitted by local power utilities. Solid-state components replace the dial units, cam shafts, and signal switches of electromechanical controllers. Manufacturers provide at least three-cycle, two-split, three-offset operation.
- 4 **Operations**. The operation of the signal by a pretimed controller unit is accomplished as follows:
- a. *Electromechanical Operation*.
- (1) *Dials*. A motor drives a timing dial through a set of gears (size of gear determines the cycle length) so that one complete revolution of the dial produces one time cycle. A pretimed controller unit may have one, two or three dials. The dial is divided into 100 equal parts. Pins or keys, placed in appropriate positions on the dial, proportion the cycle into the various phases.
  - (2) *Cams*. Each time a key on the dial actuates a microswitch, a cam shaft, on which a number of cams (plastic disks having 12, 16, or 18 lobes) are mounted, advances one position. Switches riding on the cams control particular sets of lights, i.e., one controls the main street red lights; another the main street green lights, etc. Certain lobes of each cam are broken out so that in the correct interval of the cycle the switch closes and the lights are illuminated.
- b. *Solid-State or Microprocessor Operation*. Timing information can be input with keyboard entry (most popular), thumbwheel switches, program pins, or dial-in-place (DIP) switches. Timing modifications are easily accomplished and maintenance tends to be low. Current initial cost is approximately equal to electromechanical.
- 5 **Signal timing**. Timing calculations are based on traffic requirements. Cycle lengths during off-peak periods should be as short as possible (from 40 to 60 s for two-phase signals) and still allow necessary vehicular and pedestrian movements. Longer cycles are used during peak periods to provide more green time for the major street, to permit larger platoons in the peak direction, and/or to reduce the number of starting delays. Although many factors related to specific locations must be considered, a generalized procedure for timing a signal is presented below.

- a. Calculate yellow change plus red clearance intervals based on approach speeds, using equation 15.1 (Ref. 4):

$$CP = t + \frac{V}{2a} + \frac{V}{20g} + \frac{W + L}{V} \quad [15.1]$$

- where:  $CP$  = non-dilemma change period (change + clearance interval), s  
 $t$  = perception-reaction time, s; (nominally 1 s)  
 $V$  = approach speed, m/s  
 $g$  = percent grade (positive for up, negative for down)  
 $a$  = deceleration rate, m/s<sup>2</sup>; typically 3.1 m/s<sup>2</sup>  
 $W$  = width of intersection, curb to curb, m  
 $L$  = length of vehicle, m (typically 6 m).

- b. *Determine need for red clearance*. Many jurisdictions limit the duration of the yellow change interval to 4 or 5 seconds. If the calculation from Eq. 15.1 indicates the need for a change plus clearance interval greater than the maximum yellow, a red clearance interval is used. The combination of yellow plus red clearance equal to the result from Eq. 15.1 will ensure that drivers will not be trapped in a "dilemma zone" as they approach the intersection.
- c. *Determine pedestrian clearance times* for all approaches based on an assumed pedestrian walking speed of 0.9 m/s (Ref. 3, p. 4D-5). Prior to the Americans with Disabilities Act, an assumed pedestrian walking speed of 1.2 m/s was typically used. (See also Chap. 20, part D.1.) The first portion of this clearance time is signalled with a flashing Upraised Hand/Don't Walk (FDW) indication; the last part, coinciding with the yellow interval, is shown as a steady Upraised Hand/Don't Walk (DW).

- d. *Compute minimum green times.* Minimum green time is equal to the pedestrian clearance time minus the yellow interval plus an initial interval when pedestrians may start to cross. In any case, minimum green for through traffic should be not less than 15 s.
  - (1) With pedestrian signals, the initial interval is the Walk period, normally not less than 7 s. However, it can be reduced to 4 s under special circumstances (Ref. 3, p. 4E-7).
  - (2) Without pedestrian signals, a minimum of 5 s is used for the initial interval.
- e. *Compute green time,* based on these minimums, in proportion to the approach volumes in the critical lane on each street during the peak hour. Computed greens must be greater than or equal to minimum greens calculated in step d. for both approaches.
- f. *Adjust the cycle length* (sum of all critical lane greens and yellows) to the next higher 5-s interval and redistribute extra green time. A capacity check should be made to ensure sufficient green time (i.e., cycle length is not too short).
- g. *Compute percentage values* (to nearest percent) for all intervals. It is necessary to use integer percentages since controller settings are in percent of cycle.
- h. *Install computed timing* in the controller and observe intersection operation, especially during peak periods. Field corrections in timing may be needed to provide smooth flow.

An example of timing a pretimed signal at an isolated intersection is given in Table 15-1.

**6 Flashing Operations.** During periods of low volume when normal operation is not needed to control traffic, e.g., at night, pretimed signals can be operated in a flashing mode. Signals needed only during peak hours can be operated in a flashing mode during midday off-peak periods.

- a. Major streets should have flashing yellow indications, minor streets flashing red. Where two major streets intersect, it may be desirable to flash red on both streets. An inherent problem is that the driver approaching a flashing red indication may not know what indication is being displayed on the intersecting street.
- b. Flashing rate should be between 50 and 60 times per minute. The illuminated portion of the flash should be approximately equal to the non-illuminated portion.
- c. Flashing operation is usually controlled by a time clock.

Consideration should be given to pedestrians and/or bicyclists using the intersection.

**7 Manual Operations.** Under extreme or emergency conditions it may become necessary to operate the controller unit manually. Most older controller assemblies have some provision for manual control. Newer solid state controllers do not have this provision; when manual control is desired, the intersection display is turned off.

## D. Traffic Actuated Signals

Through the use of vehicle detectors and an actuated controller unit, this type of control assigns the right of way on the basis of changing traffic demand.

### 1 Advantages of Traffic Actuated Signals.

- a. Usually reduce delay (if properly timed).
- b. Are adaptable to short-term fluctuations in traffic flow.
- c. May increase capacity (by continually reapportioning green time).
- d. Provide continuous operation under low volume conditions as an added safety feature, when pretimed signals might be put on flashing to prevent excessive delay.
- e. Are especially effective at intersections with three or more phases.

### 2 Disadvantages of Traffic Actuated Signals.

- a. The cost of an actuated installation can be from two to three times that of a pretimed signal installation, due principally to the additional cost of detectors, detector lead-ins, and controller.

**Table 15-1—Example of Signal Timing for an Isolated Intersection**

Time an isolated signal with pedestrian indications as the intersection of Pine and Oak: Pine is 17.1 m wide, Oak is 12.2 m wide. Both streets are level. During the peak hour the critical lane volumes are 300 and 225 veh/h with approach speeds of 64.4 and 40.2 km/h (17.9 and 11.2 m/s) for Pine and Oak respectively. For deceleration rates at this location use 3.0 m/s<sup>2</sup>.

a. Calculate non-dilemma change plus clearance time (Eq. 15.1):

$$\text{Pine: } 1 + \frac{17.9}{6} + \frac{12.2 + 6.0}{17.9} = 5.0s \quad \text{Oak: } 1 + \frac{11.2}{6} + \frac{17.1 + 6.0}{11.2} = 4.93s \quad \text{Use } 5.0s.$$

b. Standard yellow change intervals used by this jurisdiction; Pine - 3.5 s, Oak - 3.0 s.

Calculate red clearance intervals:

$$\text{After Pine yellow: } 5 - 3.5 = 1.5s \quad \text{After Oak yellow: } 5 - 3.0 = 2.0s.$$

c. Pedestrian clearance times:

$$\text{Pine (crossing Oak): } \frac{12.2}{0.9} = 13.6s \quad \text{Oak (crossing Pine): } \frac{17.1}{0.9} = 19.0s$$

$$\text{FDW (Pine)} = 13.6 - 3.5 = 10.1s \quad \text{FDW (Oak)} = 19.0 - 3 = 16.0s.$$

d. Minimum green times (ped. Clearance - yellow + Walk minimum)

$$\text{Pine: } 13.6 - 3.5 + 7 = 17.1s; \text{ use } 18s \text{ minimum. Oak: } 16.0 - 3 + 7 = 20.0s \star$$

e. Compute green times (using Oak as critical minimum)

$$\frac{300}{225}(20.0) = 26.7s \text{ (Pine Street green).}$$

f. Adjust cycle length and redistribute extra green time

$$\text{Total cycle} = 26.7 + 5 + 20.0 + 5 = 56.7s. \text{ Use } 60s.$$

$$\text{Extra green time} = 60 - 56.7 = 3.3s. \text{ Give } 2.3s \text{ to Pine and } 1.0s \text{ to Oak.}$$

g. Compute percentage values for all intervals for key settings.

Interval	Pine Street		Oak Street		Percent	Key Setting	
	Veh.	Ped.	Veh.	Ped.			
1	G-29	W-18	R-34	DW-34	30.0	→0	
2		FDW-11			18.3	→30	
3	Y-3.5	DW-31	G-21	W-7	5.5	→48	
4†	R-27,5				2.5	11.7	→54
5					FDW-14	23.3	→68
6						DW-5	5.0
7	R-2	3.3	→97				
8†							

G-Green Y-Yellow R-Red W-Walk DW-Steady Don't Walk FDW-Flashing Don't Walk

†Red clearance interval

\* Critical value, because it is greater than value for Pine despite the fact that Oak has the lower critical lane volume.

- b. Actuated controller units and detectors are much more complicated than pretimed electromechanical controllers, increasing maintenance and inspection skill requirements and costs.
  - c. Detectors are costly to install and require careful inspection and maintenance to ensure proper operation.
- 3 **Semi-Actuated Control.** This type of control is used in computer-controlled systems (Chap. 16) and at intersections where a major street having relatively uniform flow is crossed by a minor street with low volumes but some short sporadic peaks. Operating characteristics include:
- a. Detectors on minor approaches only.
  - b. Major phase receives a minimum green interval.
  - c. Major phase green extends indefinitely after minimum interval until interrupted by minor phase actuation.
  - d. Minor phase receives green after actuation if the major phase has completed its minimum green interval or, in a computer-controlled system, if it is at a yield point.
  - e. Minor phase has minimum initial green period.
  - f. Minor phase green may be extended by additional actuations until preset maximum is reached or a time gap in actuations greater than the unit extension occurs.
  - g. Memory features remember additional actuations if maximum has been reached on minor phase and will return green after major phase minimum interval.
  - h. Yellow change and red clearance intervals are preset for both phases.
- 4 **Full-Actuated Control.** This type of control is used at the intersection of streets or roads with relatively equal volumes, but where the distribution of traffic is varying and sporadic. Operating characteristics include:
- a. Detectors on all approaches.
  - b. Each phase has a preset initial interval that provides starting time for standing vehicles.
  - c. Green interval is extended by a preset unit extension for each actuation after the expiration of the initial interval, provided a time gap greater than the unit extension does not occur.
  - d. Green extension is limited by preset maximum limit. (Some controllers can provide for two maximums per phase.)
  - e. Yellow change and red clearance intervals are preset for each phase.
  - f. Each phase has a recall switch.
    - (1) When both recall switches are off, the green will remain on the phase being displayed when no demand is indicated on the other phase.
    - (2) When one recall switch is on, the green reverts to that phase at every opportunity.
    - (3) When both recall switches are on, the controller will cycle on a fixed-time basis in the absence of demand on either phase (one initial interval plus one vehicle interval for each phase).
- 5 **Volume-Density Control.** Volume-density control is designed for use at intersections with major traffic flows that have significant unpredictable fluctuations. To operate efficiently, this type of control needs to receive traffic information early enough to react to existing conditions. Therefore, it is essential that detectors be placed far in advance of the intersection. Operating characteristics include:
- a. Detectors on all approaches.
  - b. Each phase has a variable initial assured green time consisting of a minimum initial green interval plus added green time to accommodate additional vehicles that have arrived on the red.



- c. Passage time is the extended green time created by each additional actuation after the assured green time has elapsed. This time is set as that required to travel from the detector to the stop line. There is a preset time to reduce the passage time to a minimum gap time, and a preset minimum gap.
  - d. The maximum green extension is also predetermined and set on the controller. This feature seldom operates because of the passage time reduction feature (5.c. above).
  - e. Yellow change and red clearance intervals are set for each phase.
  - f. Each phase has a recall switch that operates in the same manner as described for full-actuated control.
- 6 Lane Occupancy Control.** This type of control is frequently used for left-turn phases at actuated installations. It may also be used for the entire intersection; in this case, traffic in all lanes around the intersection is constantly monitored by inductive loop or magnetometer detectors with extended zones of detection.
- a. Green time at an intersection is assigned on a demand basis and is terminated as soon as traffic leaves the zone of detection.
  - b. The controller unit typically rests in the all-red condition permitting instant response to approaching vehicles.
- 7 NEMA Controller Units.** Digital timing and solid state circuitry developments have led to the development of microprocessor controllers. Most major signal manufacturers produce such a controller. To provide compatibility and interchangeability, the National Electrical Manufacturers Association (NEMA) has developed interface standards, definitions, and physical and functional standards for controllers (Ref. 2). Both ITE and the International Municipal Signal Association (IMSA) have endorsed these standards.

The flexibility of these controllers, that can provide from 2 to 8 phases and differing operational modes, has resulted in their increasing use in newer installations.

- a. *Timing Modes.* Timing may be accomplished by inserting pins, setting thumb wheels or DIP switches, or through keyboard entry. The last option is becoming predominant. The following phase operations can be accomplished.
  - (1) *Pretimed.* Normally an actuated phase operating in a non-actuated mode.
  - (2) *Actuated.* Green interval has three time settings—initial, extension (gap), and maximum. The maximum time starts from detection of opposing serviceable call.
  - (3) *Volume Density.* This mode adds variable initial timing and gap reduction timing to the actuated timing.
  - (4) *Pedestrian Timing.* Concurrent pedestrian timing may be associated with any of the previous timing modes or an exclusive pedestrian phase can be used. The latter reduces the maximum number of vehicular phases that can be used to 6 on a dual ring controller or 3 on a single ring controller (7. b. below). Two time settings are required—the Walk and the flashing Don't Walk intervals.
  - (5) *Vehicle Change and Clearance Intervals.* Following the green of any phase, a yellow change interval is timed. A red clearance interval may follow the yellow.
- b. *Operation.* Operation of the NEMA controller is defined by ring, entry, and barrier (Ref. 2).
  - (1) *Single-Ring Controller Unit.* Contains two or more sequentially timed and individually selected conflicting phases so arranged as to occur in an established order.
  - (2) *Multi-Ring Controller Unit.* Contains two or more interlocked rings that are arranged to time in a preferred sequence and to allow concurrent timing of all rings.
  - (3) *Single Entry.* A mode of operation (in a multi-ring controller unit) in which a phase in one ring can be selected and timed alone if there is no demand for service in a non-conflicting phase on the parallel ring(s).

- (4) *Dual Entry*. A mode of operation in a multi-ring controller unit in which one phase in each ring must be in service. If a call does not exist in a ring when it crosses the barrier, a phase is selected in that ring to be activated by the controller unit in a pre-determined manner.
- (5) *Barrier (Compatibility Line)*. A reference point in the preferred sequence of a multi-ring controller unit at which all rings are interlocked. Barriers assure that there will be no concurrent selection and timing of conflicting phases for traffic movement in different rings. All rings cross the barrier simultaneously to select and time phases on the other side.

**8 Model 170 and 2070 Microprocessor Controller Units.** These controller units were developed as a joint effort by the states of California and New York. It is an integrated system affording complete versatility of control without hardware modification. Ref. 5 provides detailed Caltrans specifications for use of these controller units in California. Type 2070 has been developed to allow the use of ITS and adaptive traffic systems. Type 2070 is also compatible with NEMA controllers. Some of the multifunctional control capabilities of the 170/2070 controllers are:

- a. *Local intersection control* from 2- to 8-phase operation with or without volume density.
- b. *Local intersection control* with coordination in an interconnected system utilizing either full duplex phone lines or direct hardwired lines (designed to house a State Standard Compatible Modem that plugs into the unit).
- c. *Diamond interchange intersection control* in any of three operational modes — traffic responsive 4-phase 2 overlaps, traffic responsive 3-phase lag, and full traffic actuated — selectable by time of day and traffic conditions.
- d. *Ramp metering control* for isolated traffic-adjusted operation or operation from a central control facility.
- e. *Master* for a typical three-dial system or an interconnected system of local Type 170 controller units.
- f. *Traffic census count* stations.

**9 Detectors for Actuated Signals.** These devices register the presence or passage of a vehicle at the approach to an intersection or a pedestrian activating a pushbutton. There are a number of detector types, but some agencies allow the use of only certain types (for example, California typically uses only the first three types listed below for state-funded projects).

- a. *Inductive Loop Detector*. A detector that senses a change in inductance of its sensor caused by the passage or presence of a vehicle near the sensor (Ref. 6). Because of its low cost, this detector has been used most commonly for traffic signal applications.
- b. *Magnetometer-Type Detector*. A detector that measures the difference in the level of the earth's magnetic field caused by the passage or presence of a vehicle near its sensor (Ref. 6).
- c. *Magnetic Detector*. A detector that measures the difference in the level of the earth's magnetic field that is caused by the movement of a vehicle near the sensor.
- d. *Radar Detector*. An instrument mounted over or beside the roadway that detects the Doppler effect of the passage of a vehicle through its field of emitted microwave energy.
- e. *Sonic Detector*. A device mounted over or beside the roadway that reflects a beam of ultrahigh frequency sound off the pavement. A vehicle interrupting this beam is detected. Other types utilize the Doppler effect in a manner similar to the radar detector.
- f. *Pedestrian Detector*. Push buttons mounted on signal poles or on special posts adjacent to the intersection.
- g. *Bicycle Detector*. Push buttons mounted on posts conveniently placed for bicyclists are being used in areas of high bicycle use, such as universities. Some agencies use loop detectors with increased sensitivity to detect bicycles in the roadway. See Chap. 21, paragraph F.5.a.(2).

- h. *Video Camera Detector.* A detector that measures the difference in contrast of a vehicle over the surrounding background. Many agencies are now installing video cameras rather than loop detectors.
- i. *Other Detectors.* Other types of detectors have been used in the past, (e.g., infrared, optical, etc.) or are being used for special purposes (e.g., light emission to detect priority vehicles or radio-frequency detectors to identify buses. (Ref. 7).

Detection using roadside mounted acoustic devices is in an experimental stage.

**10 Timing of Actuated Signals.** Many variables are involved in the proper timing of actuated signals, e.g., type of controller unit, detector types, location, etc. Quite often traffic actuated signals are improperly timed, thereby negating the advantages of actuated equipment and causing unnecessary delay. A comprehensive treatment of timing cannot be presented here, but a few general guidelines are given below.

- a. *Initial intervals* should be kept as short as feasible. Installations using long loop detectors (12-m to 21-m loops extending back from the stop line) have relied on the presence feature of these detectors to replace the fixed initial (or added initial) with an "adjustable interval" based on demand registered by vehicles occupying the loop detector.
- b. *Unit extensions* should also be as short as possible. Long loops also permit this interval to be reduced to an absolute minimum.
- c. *Maximum intervals* should seldom be set higher than 30 to 40 s. At a well-timed intersection, maximums are seldom reached in more than three to four successive cycles. In many instances, congestion and long queues at existing intersections are the result of poor timing rather than actual traffic demand.

## E. Signal Installation Costs

The cost to construct a new traffic signal varies considerably depending on the complexity of the intersection, the type of controller unit, and the type of wiring (underground in conduit or above-ground when signal heads are span-wire mounted). A cost range of \$75,000 to \$175,000 (in 2004 dollars) would cover a large majority of new signal installations, from simple to complex.

### REFERENCES

1. Kell, J.H. and I.J. Fullerton. *Manual of Traffic Signal Design*. 2nd Ed. Englewood Cliffs, NJ: Prentice-Hall, 1991. 245 p.
2. National Electrical Manufacturers Association (NEMA). *Traffic Controller Assemblies*. Standards Publication No. TS 2-2003. Washington, DC: 2003.
3. U.S. Federal Highway Administration. *Manual on Uniform Traffic Control Devices for Streets and Highways – 2003 Edition*. Washington, DC: 2003. <http://mutcd.fhwa.dot.gov/>
4. Institute of Transportation Engineers. *Determining Vehicle Signal Change and Clearance Intervals*. Washington, DC: Publication IR-073. 1994.
5. California Department of Transportation. *Transportation Electrical Equipment Specifications*. Sacramento, CA: August 2002.
6. U.S. Department of Transportation. *Traffic Detector Handbook*. Second Ed., Washington, DC: July 1990.
7. U.S. Federal Highway Administration. *Traffic Control Systems Handbook*. Washington, DC: U.S. Dept. of Transportation, 1996.
8. Kittelson & Associates. *Evaluation of Traffic Signal Displays for Protected/Permissive Left-turn Control*. NCHRP 3-54(2), Final Report, FHWA, U.S. Dept. of Transportation, Washington, DC: 2003.

### A. System Concept

A system may be defined as an arrangement or combination of interacting or interdependent parts that form a unified whole serving a common purpose. The system concept as related to traffic signal control includes the methods, equipment, and techniques required to coordinate traffic signals and flow along an arterial or throughout an area.

- 1 **System Objective.** The major objective of a traffic control system is to permit continuous movement and/or minimize delay along an arterial or throughout a network of major streets. This involves the selection, implementation, and monitoring of the most appropriate operational plan. Basically, a traffic signal system provides the appropriate and necessary timing plans for each intersection in terms of individual needs as well as the combined needs of a series of intersections.
- 2 **Relationship of Timing Plans to Traffic Control.** In the system concept, a timing plan is defined by a combination of control parameters for one or more intersections based on an analysis of demand. Timing plans can be provided as a function of equipment at the local intersection, the central control point, or both. Timing plans consist of:
  - a. *System Cycle.* A specific cycle length is imposed throughout the system covered by the timing plan.
  - b. *Split.* Each intersection in the system has a defined split that is the apportionment of the cycle to the various phases present at that intersection.
  - c. *Offset.* Each intersection has a unique offset. The offset is the relationship of the beginning of the main street green at this intersection to a master system base time. Offset should be expressed in seconds. The difference in offset between intersections along a street defines the speed at which vehicles can travel without stopping.
- 3 **Basis for Selecting Timing Plans.** The selection parameters that define timing plans include:
  - a. *Historic Data—Time of Day.* Compiled from past traffic counts to reflect traffic volumes for specified time of day (morning peak, midday, afternoon peak, etc.) and day of week.
  - b. *Current Data.* Real-time on-street volumes.
  - c. *Special Data.* Special events, emergency route assignment, special right-of-way preemption (fire equipment, ambulance, buses, etc.).

### B. Types of Traffic Signal Control Systems

Many combinations of methods, equipment, and techniques can comprise a signal control system. Generally, these systems fall into the following basic types.

- 1 **Non-Interconnected System.** This is the crudest form of system control. Local electro-mechanical controllers can be related to one another manually using a stopwatch. Once an offset relationship has been established among a group of signals, the relationship is maintained by relying on the synchronous motors in the local controllers. Should a signal go "out of step," it must be reset manually. Such a system is limited to one timing plan and has no flexibility. It is a stop-gap measure when no other alternative is available and can only be used in older installations still using electromechanical controllers.
- 2 **Time-Based Coordinated.** This form of coordination utilizes non-interconnected controllers with auxiliary devices called time-based coordinators. These devices use the power company supplied frequency to keep time very accurately. Various timing plans can be established with time of day and day of week plan changes. Since all intersections use the same power source, the time-based coordinators provide coordination without physical interconnection.
- 3 **Interconnected Pretimed.** This type of system was originally developed for electro-mechanical controllers, but can also be used with some of the newer controllers. Local intersections are physically interconnected to ensure coordinated operation. The system provides automatic resynchronization should a signal go out of step. The number of timing plans is a function of the number of dials and the number of offsets and splits per dial; the most common system consists of a three-dial, three-offset, one-split combination. Timing plans are normally selected by a time clock or time dependent programming device. The local controller for one intersection may act as master controller for the system.
- 4 **Traffic-Responsive Interconnected Pretimed.** Basically, this is a multidial, pretimed, interconnected system utilizing a master controller for specification of cycle and offset. Traffic detectors are used to sample directional volumes. Volume levels determine which of the available cycle lengths is selected, and volume differential determines offset (i.e., inbound, outbound, or average). The master controller may be an analog or a digital computer.
- 5 **Interconnected Actuated.** Generally a small system with a master-slave relationship; i.e., two or more fully- or semi-actuated local controllers with one acting as system master and controlling cycle length for the other controllers. Offset capability is limited. A variation of this system uses a system master, coordinating units, and local actuated controllers. The master may be traffic responsive or a combination of time clocks.
- 6 **Traffic-Adjusted.** This is a background cycle system in which the master, an analog computer, directly controls the system cycle length. Usually it provides six cycle lengths, three to five offsets, and one or two splits. Offset is restricted to fixed percent of cycle length, which causes speed of progression to change whenever the cycle length is adjusted. This system is becoming obsolete because it uses special-purpose analog computer equipment and special local controllers. Systems based on digital computers can perform the same operation more effectively and economically.
- 7 **Digital Computer Signal Control.** Because of its inherent speed, programmability, and extensive logic capability, the digital computer can be used to control, operate, and supervise a traffic signal control system. Systems using a digital computer can be arranged in a variety of ways depending on specific needs. Generally, this type of system consists of the following basic components:
  - a. *Central Computer Facility.*
  - b. *Communications.* Can be via cable, telephone, radio, or a combination of these; fiber optics, lasers, and satellites are now also being considered.
  - c. *Field Equipment.*
    - (1) Local traffic signal controllers.
      - (a) Modify existing or acquire new controllers.
      - (b) Complex with backup capability or simple and inexpensive.

- (2) Detectors. (See Chap.15, Sec. D.9)
- (3) Variable message signs (blank-out, multiface, variable matrix).
- (4) Transit and emergency vehicle identification.
- (5) Other field equipment.

## C. Signal System Timing

- 1 **Simple Systems Using Pretimed Control.** The pretimed system is often found in the downtown area of a city. Available timing patterns are normally limited to a maximum combination of three cycle-split combinations and three offsets. The pattern appearing on the street generally falls into one of the following categories:
  - a. *Simultaneous Systems.* A signal system in which all signals along a street always give the same indication at the same time.
    - (1) Usually not recommended, as this system reduces capacity, increases stops, tends to encourage speeding, and provides inefficient timing.
    - (2) Best suited where blocks are short, all intersections are signalized, a major street can have most of the green time, and traffic flow is extremely high.
  - b. *Alternate System.* A signal system in which alternate signals or groups of signals give opposite indications to a given street at the same time.
    - (1) The true alternate system is operated from a single controller, but has limited application because:
      - (a) It requires 50-50 cycle split which is probably inefficient at some intersections.
      - (b) It is not well adapted to unequal block spacings.
      - (c) The double alternate system reduces platoon lengths (as shown by through bands in the time-space diagram) by 50%, triple alternate by 67%.
    - (2) It is best suited for:
      - (a) Equal spacing between signals.
      - (b) Downtown areas with square blocks, where some progression can be obtained in all directions.
  - c. *Progressive Systems.*
    - (1) *Simple Progressive System.* A signal system in which the various signal faces controlling a street give green indications in accordance with a time schedule to permit (as nearly as possible) continuous operation of groups ( platoons) of vehicles along the street at a planned rate of speed, that may vary in different parts of the system.
    - (2) *Flexible Progressive System.* A signal system in which the intervals at any signal may be independently adjusted to the traffic requirements at the intersection, and in which the green indications at separate signals may be started independently at the instant that will give the maximum efficiency. The entire system may be changed to accommodate peak-hour conditions.
  - d. *Time-Space Diagrams.* These are prepared to determine the offsets at individual intersections when progression is being established. A detailed procedure is given in Ref. 1.
    - (1) A time-space diagram is a chart on which distance is plotted against time. The location of each signalized intersection is plotted along one axis. At each such point the signal color sequence and split are plotted in such a manner that through bands are available for each direction of traffic flow. The slope of the through band (distance divided by time) is the speed of progression, and the width indicates the time available for a platoon traveling through the system.
    - (2) For two-way streets, the diagram is typically prepared to give equal consideration to each direction of travel. Where appropriate types of program controllers are available, separate peak-hour diagrams are prepared for streets carrying heavy directional peak

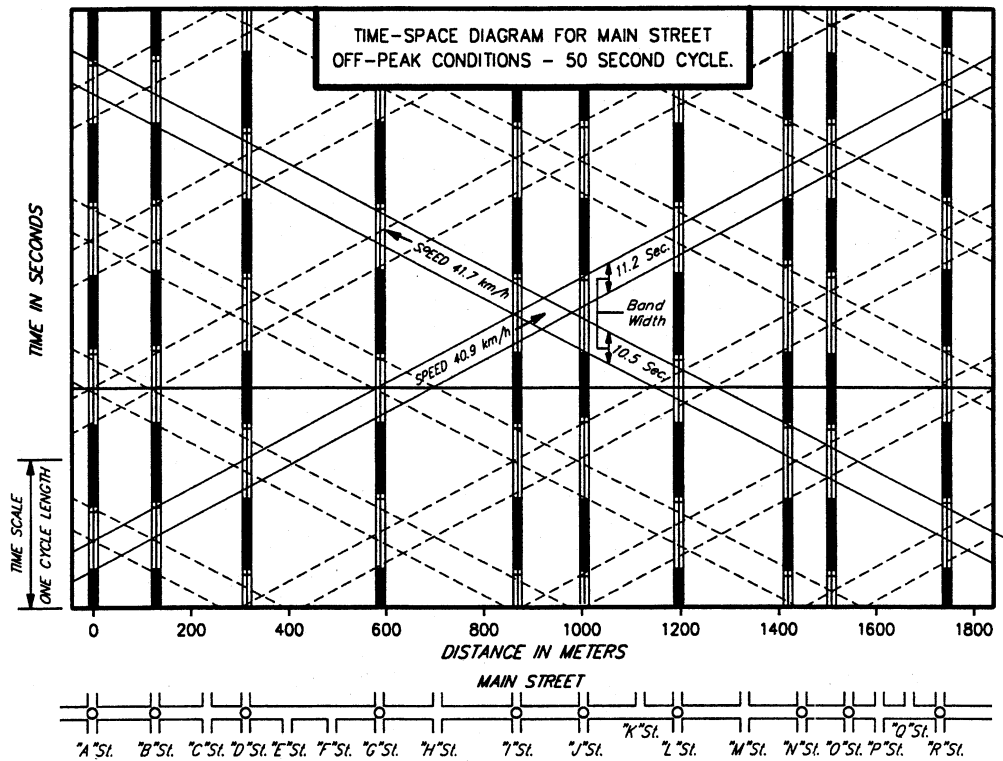

**Fig. 16-1—Time-Space Diagram Treating Both Directions of Traffic Equally**

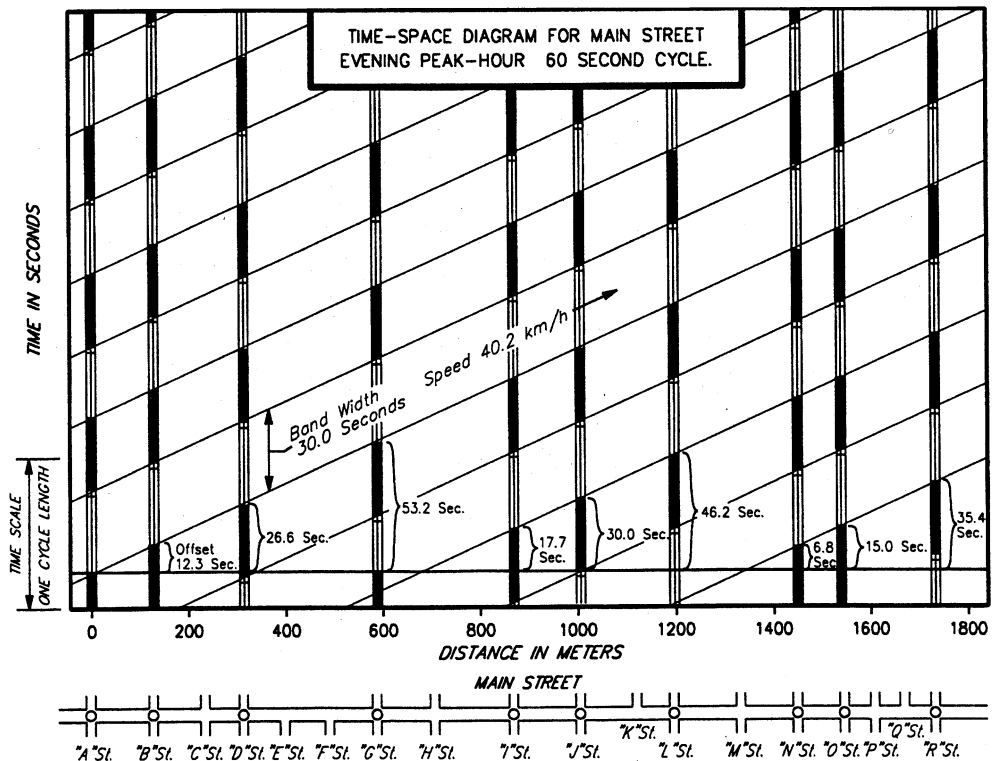

**Fig. 16-2—Time-Space Diagram Favoring One Direction of Traffic**

volumes; these will favor travel in the peak direction. The cycle length may be changed (for the entire system), and the offsets are changed through the use of time clocks in the master controller. Sample time-space diagrams for off-peak and evening peak periods are shown in Figs. 16-1 and 16-2 respectively.

- (3) When a coordinated system is established for a certain speed during all periods of the day, supplemental signs may be erected to inform the driver of that speed.

2 **Timing of More Complex Systems.** A number of computer programs are available to establish timing along arterials and in networks (Ref. 1; see also Chap. 15). Development of timing parameters and programs for more sophisticated signal systems is very specialized and depends on the specific system components and configuration. Timing techniques, methodology, and philosophy are being extensively researched to develop more effective system operation.

### D. Control Philosophies for Computerized Traffic Signal Systems

Achieving state of the art in traffic signal control systems depends on the technological development of computer applications and control philosophies. Generally, control philosophies may be categorized as follows:

- 1 **First Generation.** These programs are basically of the table look-up type. A number of essentially fixed timing patterns have been precomputed and stored. Control plans are selected based on time of day or on sensing specific demand parameters at strategically located detectors. As traffic volume threshold positions are reached, alternative predeveloped and stored control plans are implemented. This procedure is used in most of the currently operational digital computer controlled systems.
- 2 **Second Generation.** This type of control program is still based on a background cycle, but provides for on-line, real time computation of control plans and strategies. It utilizes a prediction model to determine near-term (e.g., 15-minute) changes in traffic demand. Current conditions and these predictions are then used in an on-line optimization program to compute splits and offsets.
- 3 **1.5 Generation Control.** This control type utilizes on-line data collection and predetermined algorithms to generate input data to the TRANSYT-7F timing program. A new timing plan is computed and compared to the existing timing plan. Currently, the operator must decide whether the improvement is worth implementing on either a temporary or permanent basis.
- 4 **Comparison.** The FHWA sponsored extensive research in evaluating the first and second generations of control under the Urban Traffic Control System (UTCS) program (Sec. E below). The general features of these generations are summarized in Table 16-1. The abstract of the Executive Summary of the Evaluation Study (Ref. 2) states:

"The First Generation...was found to be operationally effective, was the least expensive to apply, and should be given primary consideration for implementation. Second Generation proved effective on arterials, was only slightly more costly to implement than [first generation], and should be given consideration for areas with substantial arterial development."

**Table 16-1—Features of UTCS Strategies**

Feature	First Generation	Second Generation
Optimization	Off-line	On-line
Frequency of update	15 min.	5 min.
Number of timing patterns	Up to 40 (7 used)	Unlimited
Traffic prediction	No	Yes
Critical intersection control	Adjusts splits	Adjusts splits and offset
Hierarchies of control	Pattern selection	Pattern computation
Fixed cycle length	Within each section	Within variable groups of intersections

Source: Adapted from Ref. 3.



## E. Control System Evolution

- 1 **UTCS Program.** The UTCS program was a research and development effort of the FHWA Office of Research, Traffic Systems Division. The program included a set of interrelated projects directed toward improved traffic signal system control in urban networks. The pilot network, located in Washington, D.C., involved control of 114 signalized intersections.

The UTCS computer was turned off in 1976, primarily because of a massive rate increase for the telephone lines that formed the basic communication network for the system. Alternative communication networks were investigated, and a new system is now operating.

- 2 **Other Applications of UTCS.** The first generation UTCS software was converted to FORTRAN for use with a microcomputer installation. This version was implemented in several U.S. locations, including Bellevue, WA, Birmingham, AL, New Orleans, LA, Lincoln, NE, and Inglewood, CA.
- 3 **Extended UTCS.** The UTCS Extended Version represents an evolutionary development of the original software used in the Washington, D.C., project. The structure is very similar with the exception that the central computer main memory storage requirements are reduced through the use of overlay techniques. The major features of the Extended UTCS package that were not part of the original software include:

- Control of both full and semi-actuated controllers, including a capability for phase skipping.
- Monitoring of all controller phases instead of only the main phase.
- Increased data management capabilities, including increase or decrease of the equipment under control and signal timing modifications. These activities can be performed as background processing.
- Automatic retry of failed field equipment.
- Capability to accept operator inputs from either a CRT or a pushbutton control panel.
- Independence from particular communications formats and command structures.

The Extended Version was developed and implemented for the Charlotte, NC, system and has been further modified and implemented in other cities.

- 4 **Enhanced UTCS.** The UTCS Enhanced Version is a software package that was developed using structured programming techniques. It was designed to improve significantly on the features contained in the Extended version. Among the more significant new features are:
  - The capability of scheduling virtually all system activities with a one-minute resolution.
  - Control features such as section locking, increased number of timing plans for traffic-responsiveness, and additional actuated control features.
  - Complete capability for on-line data base update.
  - A more flexible operator interface language.
  - Off-line tape processor for evaluation of measures of effectiveness, failure analysis, and preparation of time-space diagrams.

The Enhanced Version was first implemented in Broward County, FL, and in 1984 was implemented in Los Angeles and San Diego, CA. It has been installed in several other cities since then.

- 5 **SCOOT (Split, Cycle and Offset Optimizing Technique).** Developed by the Transport and Road Research Laboratory of Great Britain, this is a traffic-responsive technique for generating coordinated signal timings for a network in real time. For each intersection, approaching traffic flows are measured and used to predict delays and queue lengths. A "signal optimizer" can adjust cycle splits by small amounts to reduce delays and queue lengths. Offsets between adjacent signals can be modified to optimize progression for major flows.

Using multiples of one second, the optimizers for splits, offsets, and cycle times can impose changes of  $\pm 4$  seconds. The overall objective of SCOOT operation is to minimize delay and stops while avoiding sudden large changes in timing.

The first U.S. installation of the SCOOT program was in Oxnard, CA. In the 1990s, a SCOOT system was implemented in Anaheim, CA. Refs. 4 and 5 provide background on the SCOOT program.

- 6 **SCAT.** The SCAT system was developed in Sydney and has been implemented in several other Australian cities (Ref. 6). The system uses dynamic cycle length changes (up to 3 seconds per cycle) to meet varying demands. Several systems are now operating in the U.S.
- 7 **Detector Location.** Research in evaluating control strategies has resulted in an extensive study of detector locations for advanced control strategies. A handbook is available (Ref. 7).

The Federal Highway Administration has published the *Traffic Control Systems Handbook* (Ref. 8). This book covers the basic principles for planning, design, and implementation of traffic control systems for urban streets and freeways.

## F. Maintenance of Signal Control Systems

Maintaining a traffic signal control system at a desired level of operation is crucial to its effectiveness.

- 1 **Physical Maintenance of Equipment.** Down time can be minimized by providing a sufficient amount of maintenance by qualified personnel. In most cases, because of its complexity, computer equipment is maintained under service contract by the manufacturer or other specialists. Other signal control equipment maintenance can be provided by in-agency technicians or under contract.
- 2 **Operational Maintenance of Systems.** To remain effective, operational programs must be updated to reflect changing conditions, and timing must be checked periodically to ensure that the timing plans are responsive to system needs.

### REFERENCES

1. Wilshire, R. "Traffic Signals." In: *Traffic Engineering Handbook. 4th Edition.* Chapter 9. Englewood Cliffs, NJ: Prentice-Hall, Inc., 1992.
2. Henry, R.D., R.A. Ferlis, and J.L. Kay. *Evaluation of UTCS Control Strategies—Executive Summary.* Washington, DC: Federal Highway Administration, 1976. 27 p. (Also Final Report. 148 p.).
3. U.S. Department of Transportation. *The Urban Traffic Control System in Washington, DC.* Washington, DC:, Sept. 1974.
4. Hunt, P.B. et al. *SCOOT, a Traffic-Responsive Method or Coordinating Signals.* Crowthorne, Great Britain: Transport and Road Research Laboratory, Report LR-1014, 1981.
5. Martin, P., and S. Hockaday. "SCOOT Update." *ITE Journal.* v. 65, n.1, Jan. 1995, pp. 44-48.
6. Lowrie, P.R. *SCATS—Sydney Coordinated Adaptive Traffic System.* Sydney: Traffic Control Section, Road and Traffic Authority of New South Wales. 1990.
7. Kell, J.H., I.J. Fullerton, and M.K. Mills. *Traffic Detector Handbook—Second Edition.* McLean, VA: U.S. Federal Highway Administration. 1990. 337 p.
8. U.S. Federal Highway Administration. *Traffic Control Systems Handbook.* Washington, DC: U.S. Dept. of Transportation, 1996.



### A. Introduction

The geometric design of streets and highways is a very complex issue. In addition to traffic engineering, highway design involves multiple specialties within civil engineering, including structural and pavement design, hydrology and drainage structures, geotechnical and materials engineering, construction engineering and management, engineering economic analyses, and elements of transportation planning. Although entire courses are devoted to each of these topics, these notes on "Fundamentals" will focus on those issues of primary relevance to the traffic engineer in creating a safe and efficient highway design.

Geometric design uses national (Ref. 1) and state (e.g., Ref. 2) guidelines to develop an appropriate design for a specific highway section. Using these guidelines, highway designers could propose countless different designs that comply with the guidelines, with each design having advantages and disadvantages. The designer must assess the alternatives and select the one that best satisfies the (often conflicting) objectives of safety, economy, environmental friendliness, and public acceptance.

AASHTO's national design guidelines and state guidelines recognize the inherent need for flexibility in geometric design. Their recommendations are not legal standards and, indeed, the tort liability regulations in most states exempt highway design decisions. According to AASHTO:

"The intent of this policy is to provide guidance to the designer by referencing a recommended range of values for critical dimensions. It is not intended to be a detailed design manual that could supercede the need for the application of sound principles by the knowledgeable design professional. Sufficient flexibility is permitted to encourage independent designs tailored to particular situations. Minimum values are either given or implied by the lower value in a given range of values. The larger values within the ranges will normally be used where the social, economic and environmental...impacts are not critical" (Ref. 1, page xliii).

Certain basic design controls and criteria become inputs to the geometric design process; most are discussed elsewhere in the following chapters:

Design vehicle dimensions and performance; driver behavior	Chap. 3.
Traffic characteristics	Chaps. 2, 4-7.
Capacity	Chap. 8.
Pedestrian and bicyclist characteristics	Chaps. 3, 8, 20-21.
Safety	Chap. 9.
Environmental compatibility, pollution	Chaps. 29-32.

### B. Street and Highway Design Elements

- 1 **Horizontal Alignment.** Curve radii, superelevation, and transitions, based on the selected design speed.
- 2 **Vertical Alignment.** Grades and vertical curves, based on topography and design speed; need for climbing lanes and/or escape ramps; minimum grades for adequate drainage.
- 3 **Combination of Horizontal and Vertical Alignment.** Provision of safe stopping and passing sight distances.
- 4 **Cross Section.** Number and width of moving lanes; need for and dimension of turning and parking lanes, shoulders, sidewalks, border areas, frontage roads, and medians; lateral clearances to obstructions; vertical clearances; pavement cross slopes, cut slopes, fill slopes; drainage ditches; marginal treatment (access control, driveways, etc.).

### C. General Design Policies

At the beginning of the design process, the engineer must determine or specify values for six primary factors that will influence a highway's geometric design. These elements are area (urban or rural), functional classification (see Chap. 12, Sec. D), topography (level, rolling, or mountainous), design vehicle (passenger vehicles, trucks), design speed, and design hourly volume. Table 17-1 shows selected design parameters for four highway classes. Recommendations for the most critical design criteria are discussed below.

**Table 17-1—Design Criteria of Highway Types Feature Freeway Expressway**

Feature	Freeway	Expressway/Parkway	Arterial	Collector Local Street
Control of access	Full	Full or partial	Usually none	None
Minor cross streets	Terminated	Terminated	At grade	At grade
Major cross streets	Separated	Some at grade	At grade	At grade
Intersection control	—	Signals; some STOP signs	STOP signs or signals	None*
Private driveways to through lanes	None	None	Restricted; some "right turn only"	Unrestricted
Access connection treatment	Ramps	Channelized or ramps	Normal or flared	Normal
Frontage roads	Where needed	Where needed	Usually none	None
Median	Continuous	Interrupted at intersections	Where feasible	None†
Pedestrian crossings	Separated	Crosswalks or separated	Crosswalks	Unmarked crosswalks
Curb parking	None	None	Restricted or eliminated if necessary	Unrestricted

\* - At intersections of collector roads with local streets, some YIELD or STOP signs may be warranted.

† - Unless desired for landscaping.

- 1 **Design Speed.** Horizontal and vertical alignment dimensions are dictated by the design speed chosen for the facility. Ref. 1 recommends the values shown in the upper half of Table 17-2. To the extent possible, the design speed should be consistent throughout the highway section.
- 2 **Maximum Grade.** The maximum grades recommended for different environments are listed in the lower half of Table 17-2.

**3 Horizontal Curves.** Two components make up the design of a horizontal curve:

- a. *Superelevation.* In urban areas, the maximum rate of superelevation for all types of facilities is 0.06. In rural areas, the superelevation rate may range up to 0.08 where icing is a problem, and up to 0.12 elsewhere.
- b. *Minimum Radius.* The basic formula for minimum curve radii based on the design speed and superelevation is:

$$R_{min} = \frac{V^2}{127(0.01e + f)} \tag{17.1}$$

- where  $R_{min}$  = minimum radius (m)
- $V$  = design speed (km/h)
- $e$  = rate of roadway superelevation (percent)
- $f$  = side friction factor (0.28 at 30 km/h, decreasing to 0.08 at 13 km/h)

**Table 17-2—Design Speeds and Maximum Grades**

	Location	Freeway	Arterial	Collector	Local
<b>Minimum Design Speed (km/h)</b>					
Rural	Level	110 -120	100 – 120	80 – 100	50 – 80
	Rolling	110 <sup>a</sup>	80–100	50 – 70	30 – 60
	Mountainous	80 – 100	60 – 80	40 – 70	30 – 50
Urban		80 – 110	60 <sup>b</sup> – 100	50 - 60	30 – 50
<b>Maximum Grade (percent)</b>					
Rural	Level	3	3	5 – 6	6 – 7
	Rolling	4	4 – 5	8 – 9	10 – 11
	Mountainous	5	7– 8	10 – 11	14 – 16
Urban	Level	3– 4 <sup>c</sup>	5 – 7	7	8 <sup>d</sup> , 15 <sup>e</sup>
	Rolling	4 – 5 <sup>c</sup>	6 – 8	8 – 9	8 <sup>d</sup> , 15 <sup>e</sup>
	Mountainous	5 – 6	8 – 11	10 – 11	8 <sup>d</sup> , 15 <sup>e</sup>

Source: Ref. 1.

- a - Implied in the text of Ref. 1.
- b - 50 km/h in CBDs and intermediate areas.
- c - 1% steeper "in extreme cases where development precludes the use of flatter grades", and for one-way downgrades.
- d - In commercial and industrial areas.
- e - In residential areas.

**4 Stopping Sight Distance.** The premise of stopping sight distance (SSD) is that a driver should be able to see sufficiently far distance ahead to perceive and react to an unexpected object in the road and brake to a stop before reaching it. The concept, which applies to all facilities from local streets to freeways, becomes a design consideration in the vicinity of vertical and horizontal curves, both of which may restrict sight distance. According to AASHTO (Ref. 1), the minimum desirable stopping sight distance  $d$  (m) is calculated in the following manner:

$$d = (0.278)Vt + 0.039 \frac{V^2}{a} \tag{17.2}$$

- where  $V$  = design speed (km/h)
- $t$  = brake reaction time, assumed to be 2.5 s for design
- $a$  = acceptable deceleration, assumed to be 3.4 m/s<sup>2</sup> for all speeds

General SSD principles were introduced 60 years ago, and since then, changes have been made in the values of assumed parameters. A recent thorough review of SSD concepts (Ref. 4) recommended several changes in the methods of calculating and applying stopping sight distance.

5 **Highway Safety Design.** Geometric design standards contribute to improved highway safety. However, Ref. 1 (and its earlier versions) overlooked some fine points of design and operations that might further enhance safety. In the late 1960s AASHTO recognized this shortcoming and published a guide to fill this gap; the current version of this guide (Ref. 4) recommends subtle safety improvements for freeways, rural highways, and urban streets.

The Federal Highway Administration has developed an Interactive Highway Safety Design Model (IHSDM), a suite of evaluation tools for assessing the safety impacts of geometric design decisions. The initial development efforts concentrate on two-lane rural highways. According to Ref. 5, IHSDM will consist of six modules:

- a. Crash prediction module to estimate the number and severity of crashes
- b. Design consistency module to assess roadway conformity with driver expectations
- c. Driver/vehicle module to estimate the vehicle's speed and path
- d. Intersection diagnostic module to evaluate intersection design alternatives
- e. Policy review module to ensure compliance with highway design policies
- f. Traffic analysis module to simulate the operational effects of road designs

6 **Flexible Design.** Many designers believe that compliance with AASHTO design criteria will produce efficient streets and highways. In some cases, however, properly designed roads have been built that are out of context with their surroundings. Federal highway legislation in 1991 and 1995 encouraged designers to use creative thinking in the design or redesign of roadways in areas of historic or scenic value. A recent guide (Ref. 6) identifies design approaches that consider aesthetic, historic, and scenic values, along with the traditional criteria of safety and mobility.

### D. Cross Section Design Criteria for Urban Streets

Table 17-3 shows AASHTO's guidelines for cross section element widths on urban collector and local streets. Greater border and median widths may be appropriate in some cases. Figs. 17-1 and 17-2 show cross sections for major urban arterials and expressways. See Ref. 1 for illustrations of details.

**Table 17-3—Cross Section Design Criteria for Urban Streets**

Design Element	Arterial	Collector		Local	
		Residential	Other	Residential	Other
Number of through traffic lanes	4 – 8	2	2 – 4	1 – 2 <sup>a</sup>	2 – 4
Width of traffic lanes, m	3.0 – 3.6	3.0 – 3.6	3.3 – 3.6	2.7 – 3.3 <sup>b</sup>	3.0 – 3.6
Width of turn lanes, m	3.0	—	3.0 – 3.6	—	3.0 – 3.6
Width of CLT <sup>c</sup> , m	3.3	—	3.3	—	—
Width of parking lane, m	3.0 – 3.6	2.1 – 3.0	2.4 – 3.0	2.1 – 2.4	2.7
Width of border/sidewalk area, m	2.4 – 3.6	2.4 – 3.3	2.4 – 3.3	1.5 – 3.0	1.5 – 3.0
Width of median, m	1.2 – 5.4 <sup>d</sup>	—	0.6 – 4.8 <sup>d</sup>	—	—

Source: Based on Ref. 1.

- a - One lane in low-density residential areas, but see D.1. below.
- b - 3.6 m if only one lane is provided.
- c - CLT continuous two-way left-turn lane.
- d - Upper end of range based on accommodating left-turn lane at intersections.

1 **Number of Lanes.** Local streets in low-density residential areas generally have two moving lanes. Ref. 1 recognizes one 3.6-m lane as a possible alternative, if flanked by two 2.2-m parking lanes for a total roadway width of 8 m. However, this may prove to be inadequate in cases of natural disasters (e.g., fire and hurricane evacuations), and should not be used unless multiple egress routes are available. Collector streets may require up to four lanes, although two lanes are usually sufficient. In business and industrial districts additional width may be needed to handle local traffic and access needs (e.g., truck unloading in industrial areas). The number of lanes on arterials depends on the capacity needed to handle present and future design hour volumes, turning movements requirements, and access needs. If traffic demand requires more than the recommended maximum of eight lanes, development of an expressway or freeway is desirable.

- 2 **Lane Width.** Lanes 2.7–3.3 m wide are usually adequate for local streets in residential areas. Wider lanes, up to 3.6 m, are needed as speed, volume, and design vehicle size increase. Auxiliary lanes for right and left turning traffic at intersections should be at least 3.0 m wide.
- 3 **Width of Parking Lanes.** Passenger vehicles parked parallel to the roadway require a width of 2.1 m. However, 0.9 m should be added to allow sufficient side clearance between vehicles and obstructions, for a total width of 3.0 m. This will permit drivers to operate in the middle of the adjacent lane and avoid crowding other traffic lanes. For angle parking dimensions, see Chap. 23. A single parking lane may be provided on streets carrying low volumes in residential areas, especially in steep terrain. Many jurisdictions do not provide parking on major arterials.
- 4 **Provision for Bicycles.** On arterial and collector streets where bicycles share the roadway with motor vehicles, the curb lane should be wider than stated above. See Chap. 21 for more details.
- 5 **Border/Sidewalk Area.** Border/sidewalk areas are the street property between the roadway and the right-of-way line. In business districts, this area is devoted to sidewalks and parking meter and utility pole location. Minimum widths are shown in Table 17-3. See Chap. 20 for more details.
- 6 **Medians.** On arterials, a median width of 5.4 m is desirable to contain 3.6-m wide left-turn lanes; the minimum is 3.6 m with 3.0-m wide left-turn lanes or 1.2 m if left-turn lanes are not provided. However, these widths are insufficient to adequately shield a crossing vehicle, particularly at an unsignalized intersection. Median widths at these locations should accommodate the design vehicle making a crossing maneuver, necessitating a width of 6 – 20 m. Where driveways of important traffic generators are located in the middle of very long blocks, a mid-block opening with left-turn storage may be justified. If driveways occur frequently, a two-way left-turn lane may be used in place of a median (Chap. 24, Sec. D).
- 7 **Driveways.** The location of driveways must be controlled to minimize marginal friction. Table 17-4 lists some guidelines for driveway dimensions. The maximum recommended number of driveways for an individual property is: 1 for frontages less than 15 m, 2 for frontages of 15–45 m, 3 for frontages of 45–150 m, and 4 for frontages exceeding 150 m. Ref. 7 also gives details of driveway profiles, general principles, and illustrative examples.

**Table 17-4—Recommended Basic Driveway Dimension Guidelines**

	Residential	Commercial	Industrial
Width (m)			
one-way driveways	3.0	4.6	6.1
two-way driveways	3.0 – 7.3	9.1 – 11.0 <sup>a</sup>	12.2 – 15.2
Minimum curb return radius <sup>b</sup>	1.5	4.6	6.1
Minimum spacing <sup>c</sup>			
street corner to driveway	1.5	3.0	3.0
between adjacent driveways	0.9	0.9	3.0
Minimum angle	45°	45°	30°

Source: Adapted from Ref. 78, Table 2.

*a* - A 11.0-m driveway is usually marked with two exit lanes and one entry lane.

*b* - For major traffic generators radii should be much higher.

*c* - Dimension for tangent between adjacent curb returns.

- 8 **Curbs.** Curbs are used on city streets to deter vehicles from leaving the roadway and for drainage purposes. The vehicle redirection capability of curbs decreases at higher speeds and greater angles of impact. Mountable curbs are sometimes used on residential streets with border areas where no parking lane has been provided. Curb cuts are provided at driveways and for wheelchair ramps.
- 9 **Width of Structures.** The width of structures on urban streets should equal the width of the approaching roadway and sidewalks; the same applies at underpasses. Where there are no



sidewalks, a minimum horizontal clearance of 1.8 m between the outer traffic lane edges and the abutments and/or columns should be provided.

- 10 Treatment of Local Residential Streets for Traffic Calming.** Many local residential streets were laid out in the past with generous geometric cross sections. As a result, they may attract excessive traffic, possibly at high speeds. Tools to mitigate these problems are described in Chap. 34. For more information on residential street design and redesign, see also Ref. 8.

## E. Cross Section Design Criteria for Rural Highways

In comparison with most urban streets, rural highways are characterized by higher design speeds, a higher proportion of large trucks, essential but less frequent access to abutting properties, few pedestrians, no regular demand for parking, and more unfamiliar drivers. Important design guidelines for uncontrolled-access rural highways are given below.

- 1 **Number of Moving Lanes.** This depends on present and future design hour volumes. Rural roads are usually built with a minimum of two lanes, although many older roads with pavement widths of 5.5 m or less still exist.
- 2 **Lane Width.** The normal width is 3.6 m for major rural highways, 2.7–3.3 m for minor roads.
- 3 **Shoulders.** Minimum recommended width is 0.6–2.4 m, depending on traffic volumes. California specifies 2.4 m, but narrower shoulders are permitted on 2-lane roads with ADT of less than 400 and on the right side of uphill lanes for slow-moving traffic (Ref. 2, Tables 302.1 and 307.2).
- 4 **Driveways.** The guidelines in Ref. 7 apply equally to driveways in urban and rural areas.
- 5 **Medians.** The minimum median width on rural multilane highways in both Refs. 1 and 2 is 3.6 m, but Ref. 1 recommends a width of 20 m where feasible to reduce crossover accidents and headlight glare. Under restrictive conditions, especially in mountainous terrain, 1.2-m medians may be used; rigid median barriers should be considered for these sites. A number of highway agencies are using median or centerline rumble strips to discourage cross-median excursions.
- 6 **Very Low-Volume Local Roads.** AASHTO recognizes that the policy expressed in Ref. 1 is too demanding for low-volume roads, defined as "a road that is functionally classified as a local road and has a design average daily traffic volume of 400 vehicles per day or less" (Ref. 9). To accommodate these facilities, many of which are designed, operated, and maintained by county road agencies, AASHTO published guidelines that supplement Ref. 1 and relax the values cited in the AASHTO Policy. With respect to the stopping sight distance requirements discussed in Ref. 1, for example, the very-low volume road perception-reaction time is reduced to 2 s and the deceleration rate is increased to 4.1 m/s<sup>2</sup>. Exhibit 3.1 in Ref. 1 recommends a SSD of 65 m for a design speed of 50 km/h. With the modifications noted at this design speed, Ref. 9 recommends 45 m for volumes ≤100 vpd and 55 m for higher volumes and "higher risk" locations.

## F. Cross Section Design Criteria for Freeways

Characteristics that differentiate freeways from all other roads are the emphasis on moving traffic rather than providing land access, design speeds in excess of 100 km/h, substantial volumes of large trucks, a significant proportion of out-of-area drivers, and high volumes (relative to other streets and highways) of nighttime traffic. In 2003, Interstate freeways carried 24% of the vehicle-kilometers of traffic in the U.S. and had a fatality rate about half the national average. The major contributors to safety on freeways are separating the directions of travel; limiting access; and providing clear, recoverable roadsides. Refs. 1 and 2 provide extensive detail on freeway design. Chap. 18 discusses interchange design, and Chap. 25 discusses freeway operation.

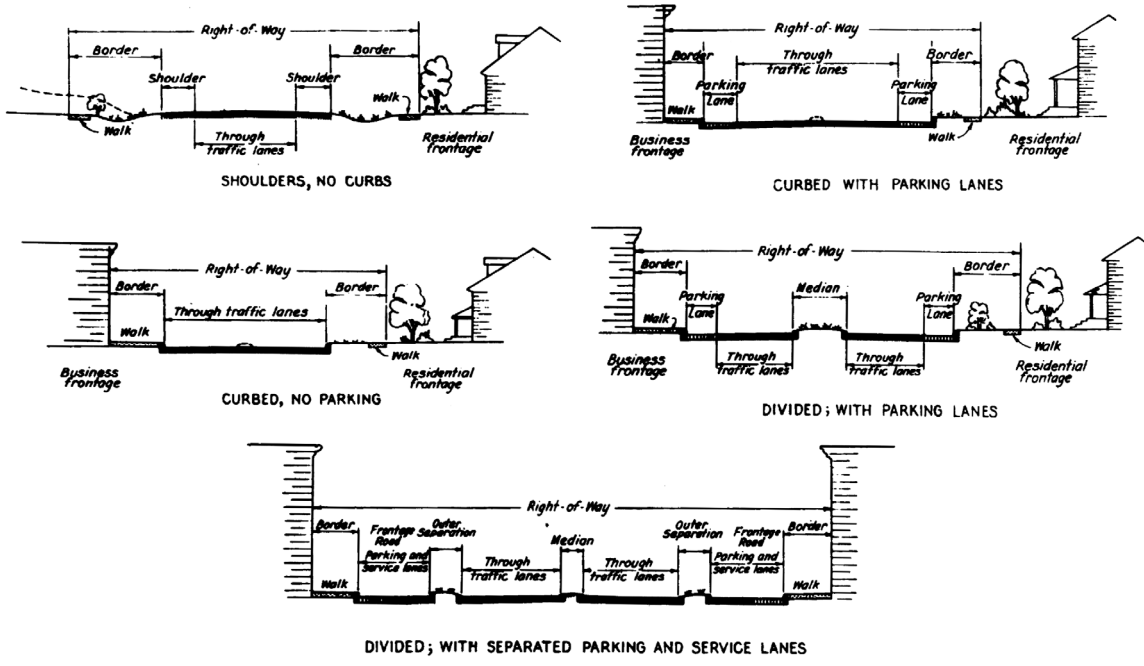

Fig. 17-1—Cross Sections of Major Arterials

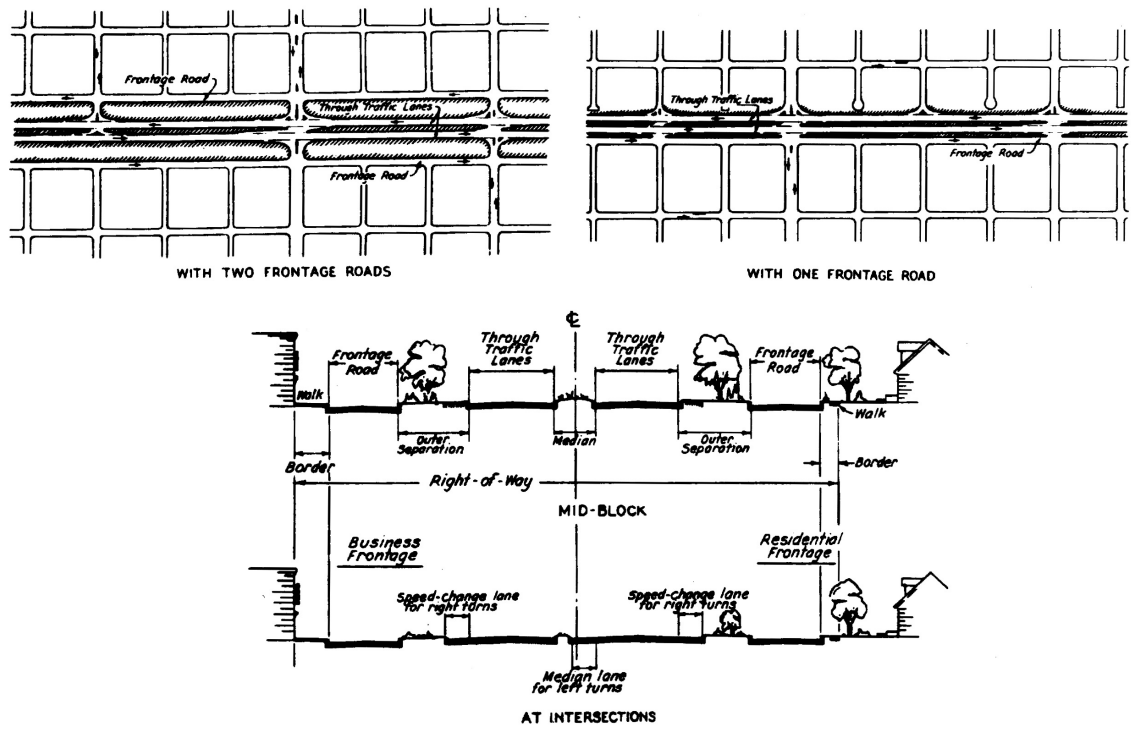

Fig. 17-2—Cross Sections of Expressways at Grade

- 1 **Number of Lanes and Roadways.** The minimum freeway cross section consists of two roadways, each with two traffic lanes. The maximum number of lanes per roadway is usually four, although sections of five- six-, and even seven-lane roadways have been built. Where more lanes in one direction are needed, a third (reversible) or two additional roadways may be provided.
- 2 **Reversible Roadway.** Where traffic forecasts indicate a major imbalance in directional design hourly volumes (DDHV), a third, reversible roadway – usually 2–4 lanes wide – can be provided. This roadway may carry general or only HOV traffic; it may not be connected to some interchanges or ramps in intermediate areas. At its termini the roadway may feed to and from the outer roadways via "slip ramps" under control of automatic gates and variable message signs. In downtown areas the roadway may be connected by its own set of ramps to the street system. Reversible roadways are found on freeways in San Diego, Chicago, St. Louis, Seattle, and northern Virginia, and on selected bridges and tunnels. See Chap. 25, Sec. D.6.a.
- 3 **Lane Width.** The normal width of freeway lanes is 3.6 m. In some cases, lanes have been restriped to a width of 3.3 m, and a part of the right shoulder has been used to squeeze an additional lane from the existing three or four lanes.
- 4 **Shoulders.** Shoulders are provided on both sides of each roadway for emergency stopping and to allow operators of errant vehicles room to recover control. Ref. 1 recommends a width of 3.6 m where the truck DDHV exceeds 250 (3.0 m otherwise). The shoulder along the-median ranges from 1.2-3.0 m, with 3.6 m again recommended for higher truck volumes.
- 5 **Noise Barriers.** Cross-section space may have to be allocated to noise barriers in order to achieve the standards listed in Table 31-3 of Chap. 31. Horizontal clearance should meet the criteria for clear zones in Ref. 10. If the clearance is 4.5 m or less, the noise barrier must be placed on a concrete safety shape barrier.
- 6 **Medians.** AASHTO (Ref. 1) recommends 3-8 m medians in urban areas and 18-27 m in rural areas. California's *Design Manual* (Ref. 2, para. 305.1) recommends a basic median width of 18.6 m in rural and suburban areas; in urban areas the basic width is 13.8 m, with 10.8 m minimum if the recommended width cannot be provided at reasonable cost. If future widening in the median is contemplated, the initial width must be correspondingly greater. In rural areas, the two roadways may be placed on different vertical and horizontal alignments for aesthetic or topographic reasons.
- 7 **Median Barriers.** Because medians do not preclude the possibility of errant vehicles crossing into the opposite roadway, barriers are provided in crucial areas. AASHTO's warrants for median barriers are based on traffic volume and median width (Ref. 9). California median barrier warrants (Ref. 10) also consider recent cross-median accident experience.
  - a. *Concrete Barrier.* Concrete safety shape barriers are 610 mm wide at the base, contouring to 150 mm at the top, with a total height of 800 mm. The barrier does not deflect on impact and thus requires little maintenance. In California, it is the standard for medians up to 11 m wide.
  - b. *Thrie-Beam Barrier.* A Thrie-Beam barrier uses a 12-gauge triple corrugated steel beam mounted with block-outs on wood or galvanized steel posts. The top of the mounted rail is 810 mm. This barrier deflects up to 0.6 m on high-speed impact by a 2000 kg vehicle. It is the California standard for medians more than 11 m wide; under special conditions, it may be used for medians 6–11 m wide.
- 8 **Glare Screens.** To limit headlight glare from oncoming traffic, glare screens of expanded metal mesh are used on medians up to 6 m wide, except on horizontal curves where visibility would be reduced below the standard for safe stopping distance (Ref. 10). Planting may be used on wider medians to screen out glare.
- 9 **Cross Section on Structures.** Whenever possible, the cross section on freeway structures should be the same as on their approaches. Where the structures are very long, however, median and shoulder widths can be reduced. Shoulders may have to be eliminated altogether,

except for an offset of 0.6 m between the outer lane and the curb or 1.2 m between the lane and parapet. A similar clearance should be provided between the lane nearest the median and the median barrier. The median itself should be at least 1.2 m wide.

- 10 **Cross Section and Clearance under Structures.** Vertical clearance in most states is 4.2–5.2 m. In California, clearance of 5.1 m is required for structures on freeways and expressways; this can be reduced to 4.9 m after completion of a pavement overlay project. On conventional highways and local streets, clearances must be 4.6 m over the traveled way and 4.5 m over the shoulders. Minor pedestrian grade separations must have clearances 0.6 m more than the applicable minima for major structures. The vertical clearance under sign bridges is 5.5 m (Ref. 2, para. 309.2).
- 11 **Rail Transit in Freeway Median** (Ref. 1, Chap.VIII). If right-of-way for a rail transit line will be provided in the freeway median, the median design dimensions will be affected. Horizontal curvatures and grades specified for freeways are adequate for rapid transit trains and light rail vehicles. (In the rare instance where the median is to be used by an intercity railroad – e.g., I-10 east of Los Angeles — the railroad's grade and curvature limits may govern.) The minimum median width must be 12 m to contain two rail tracks between stations; to accommodate passenger platforms, the width must be increased by 4–9 m at stations. Roadways adjacent to the transit medians must carry the usual inside shoulders and drainage areas. Because fencing of the rail right-of-way is essential, minimum lateral clearances must be maintained.
- 12 **Aesthetic Features.** The geometric design of freeways and arterials may include special features to enhance the aesthetic appearance of the facility. These may include medians of variable width and split-level arrangements of roadways, curves to interrupt long, monotonous tangent alignments, changes in roadway alignment to provide attractive vistas to the driver, and roadside picnic and rest areas.

#### REFERENCES

1. American Association of State Highway and Transportation Officials. *A Policy on Geometric Design of Highways and Streets, 2004*. Washington, DC: 2004, 896 p.
2. California Department of Transportation. *Highway Design Manual*. Sacramento, CA: 2001 with 2004 revisions. Available at: [www.dot.ca.gov/hq/oppd/hdm/hdmtoc.htm](http://www.dot.ca.gov/hq/oppd/hdm/hdmtoc.htm).
3. Fambro, D.B. *Determination of Stopping Sight Distances*. Washington, DC: Transportation Research Board, NCHRP Report 400, 1997.
4. American Association of State Highway and Transportation Officials. *Highway Safety Design and Operations Guide*. Washington, DC: 1997.
5. Federal Highway Administration. *IHSDM Overview*. <http://www.tfhr.gov/safety/ihsdm/ihsdm.htm>.
6. Federal Highway Administration. *Flexibility in Highway Design*. Washington, DC. 7-062, 1997. Available at: <http://www.fhwa.dot.gov/environment/flex/>.
7. Institute of Transportation Engineers. *Guidelines for Driveway Design and Location*. Washington, DC: 1987, 23 p.
8. Homburger, Wolfgang S. et al. *Residential Street Design and Traffic Control*. Englewood Cliffs, NJ: Prentice-Hall, 1989.
9. American Association of State Highway and Transportation Officials. *Guidelines for Geometric Design of Very Low-Volume Local Roads (ADTÆ400), 2001*. Washington, DC:
10. American Association of State Highway and Transportation Officials. *Roadside Design Guide*. Washington, DC: 2002.
11. California Department of Transportation. *California Supplement to the MUTCD*. Sacramento, CA: 2004. Available at: <http://www.dot.ca.gov/hq/traffops/signtech/mutcdsupp/>.



**A. Introduction**

Functionally speaking, intersections are defined as meeting points (nodes) of links that are either freeways, major streets (highways), or minor streets (roads). Where a freeway is involved, the intersection is partially or completely grade-separated, and is called an *interchange*.

**B. Intersection Design Elements**

Geometric types of intersections are illustrated in Fig. 18-1. See Ref. 1 and Ref. 2, Chap. 9 for detailed treatments of the geometric design of intersections. Major elements in intersection design include:

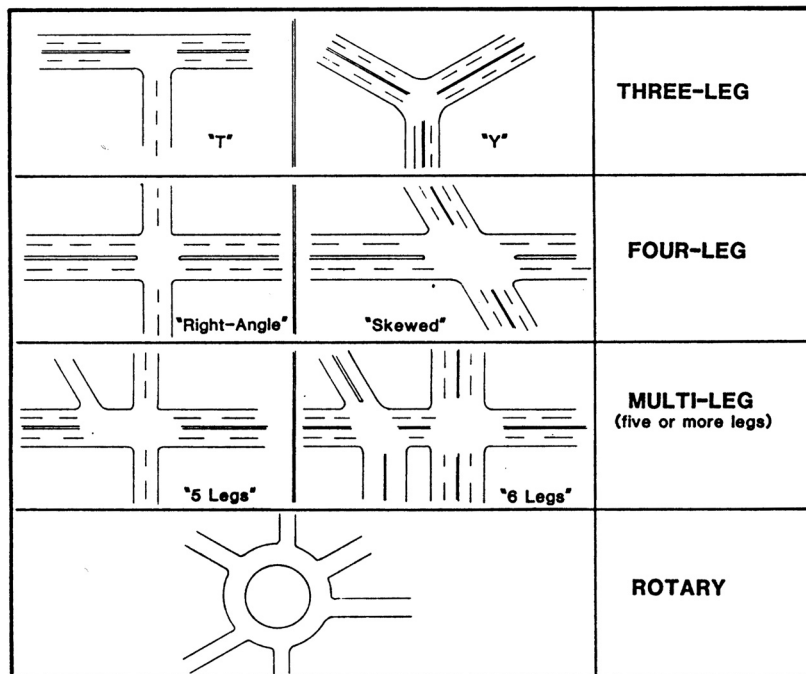
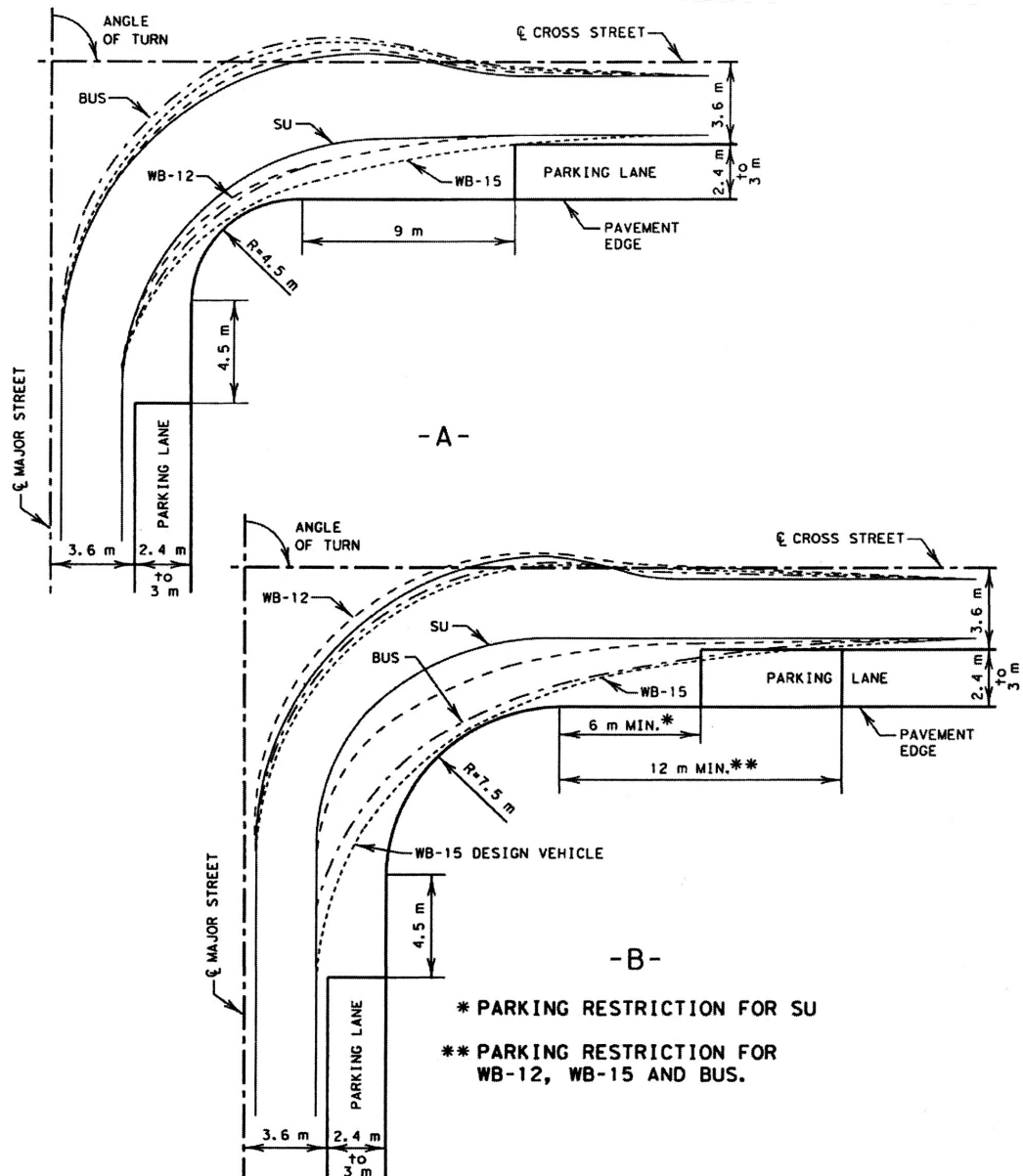

**Fig. 18-1—Basic Intersection Types**

- Sight Distance.** Adequate sight distance must be provided for drivers approaching and entering intersections. Refs. 2 and 3 present recommended values. A recent report (Ref. 4) documents a thorough study of the theoretical and practical sight distance issues for six primary situations:

- a. Intersections with no control (i.e., the basic right-of-way rule).
- b. Intersections with STOP control on the minor road; crossing maneuvers, turns to left or right.
- c. Intersections with YIELD control on the minor road; crossing maneuvers, turns to right or left.
- d. Intersections with traffic signal control.
- e. Intersections with all-way STOP control.
- f. Vehicles making left turns from the major street.

Design values for intersection sight distance depend on approach speed, street width, vehicle type, assumed deceleration and acceleration rates, and the stopped position chosen by drivers.



**Fig. 18-2—Effect of Curb Radii and Parking on Turning Paths**

Source: *A Policy on Geometric Design of Highways and Streets*.  
 Copyright 2004 by the American Association of State Highway and  
 Transportation Officials, Washington, DC. Used by permission.

- 2 **Curb Radii.** These constrain the paths that vehicles follow when making turns. The physical area of an intersection can be decreased by reducing the curb radii at the corners. However, as Fig. 18-2 shows, large vehicles will encroach on adjacent lanes if the curb radius is too small. Curb parking near the intersection must be prohibited as shown in the figure to keep the curb lane free for encroachment by turning buses and trucks. But, if curb parking is completely prohibited, and the curb lane is used for moving traffic, the problem of large vehicles is compounded; encroachment into other traffic lanes is probable. At a right-angle intersection, even with a 12-m radius, a bus requires 6.5 m of the cross street width to complete the turn. The benefits of accommodating turning movements of large vehicles must be weighed against the added operational problems of the larger intersection created thereby.

In rural areas, where land is less expensive and where fewer pedestrians cross at intersections, large curb radii can often be used. Three-centered curves or offset simple curves in conjunction with tapers or spirals reduce the radius requirements and are therefore preferred where the volume of large vehicles is significant. Exhibits 9-19 and 9-20 in Ref. 2 list radii needed for simple and compound curves.

- 3 **Free Right-Turn Lanes.** These should be provided where right-of-way is available and where the volume of right turns warrants this treatment. Generally, the right-turn lane is separated from the rest of the intersection by a traffic island (Figs. 18-3, 18-4); in urban areas this also serves as a pedestrian refuge.
- 4 **Left-Turn Lanes.** These are provided where the volume of left-turn traffic warrants them. On streets with medians, the left-turn lane is recessed into the median. On rural highways without medians, left-turn lanes can often be provided by shifting the through lanes for one or both directions outwards. On city streets, it is sometimes possible to prohibit curb parking and move the through lanes toward the curb to accommodate a left-turn lane. For large turning movement volumes, double left-turn lanes can be provided (Fig. 18-4).
- 5 **Tapers.** Tapers for turning vehicle acceleration or deceleration are provided on high-speed roads (Fig. 18-3) to improve traffic flow conditions. Tapers are designed so that an entering vehicle can accelerate to the speed of through traffic before it begins the actual merging maneuver, and that a diverging vehicle need not begin to decelerate until it has completely exited the through lane. Taper rates on high-speed highways are typically in the range 8:1 to 15:1 (longitudinal:transverse). On city streets there is usually less opportunity to provide acceleration and deceleration lanes; however, the lower speed of through traffic reduces the need for such lanes.
- 6 **Wheelchair Ramps.** Wheelchair ramps are required at street intersections and where pedestrian crosswalks intersect raised medians or islands. Refs. 2, 3, (Sec. 105.3), and 6 give guidelines for ramp location and design. The California Department of Transportation has developed designs for use by local jurisdictions. Ramps can be provided by rebuilding sections of sidewalk so that they slope to meet the street grade at the gutter. Where a landscaped border strip separates the sidewalk from the curb, the ramp can be built within this strip and the sidewalk remains undisturbed.

The maximum slope in the direction of the wheelchair paths is 1:12 (V:H), transverse to the wheelchair path 1:50. A 300-mm border around the upper limit of the ramp is grooved (assuming concrete sidewalks) as a guide for blind persons; the ramp itself is also grooved if it is placed in the center of a curb return (i.e., one ramp for both crosswalks from that corner) in such a way that blind persons can find their way to the appropriate crosswalk.

- 7 **Treatment of Minor Intersections in Residential Areas.** Design and redesign of intersections to promote traffic calming in residential neighborhoods are discussed in Chap. 34.



NOTE: 1' = 0.3048 m

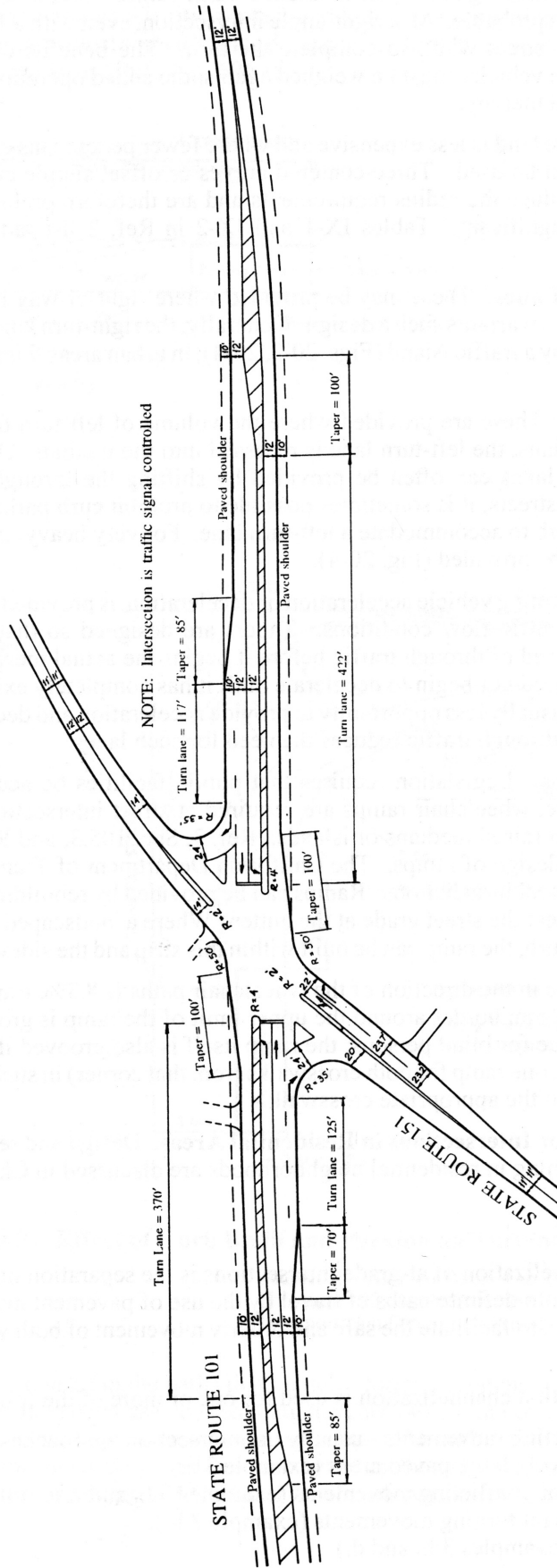

Source: Ref. 3.

**Fig. 18-3- Intersection in a Rural Area**  
 State Route 101 approaches widened; left-turn lanes provided.

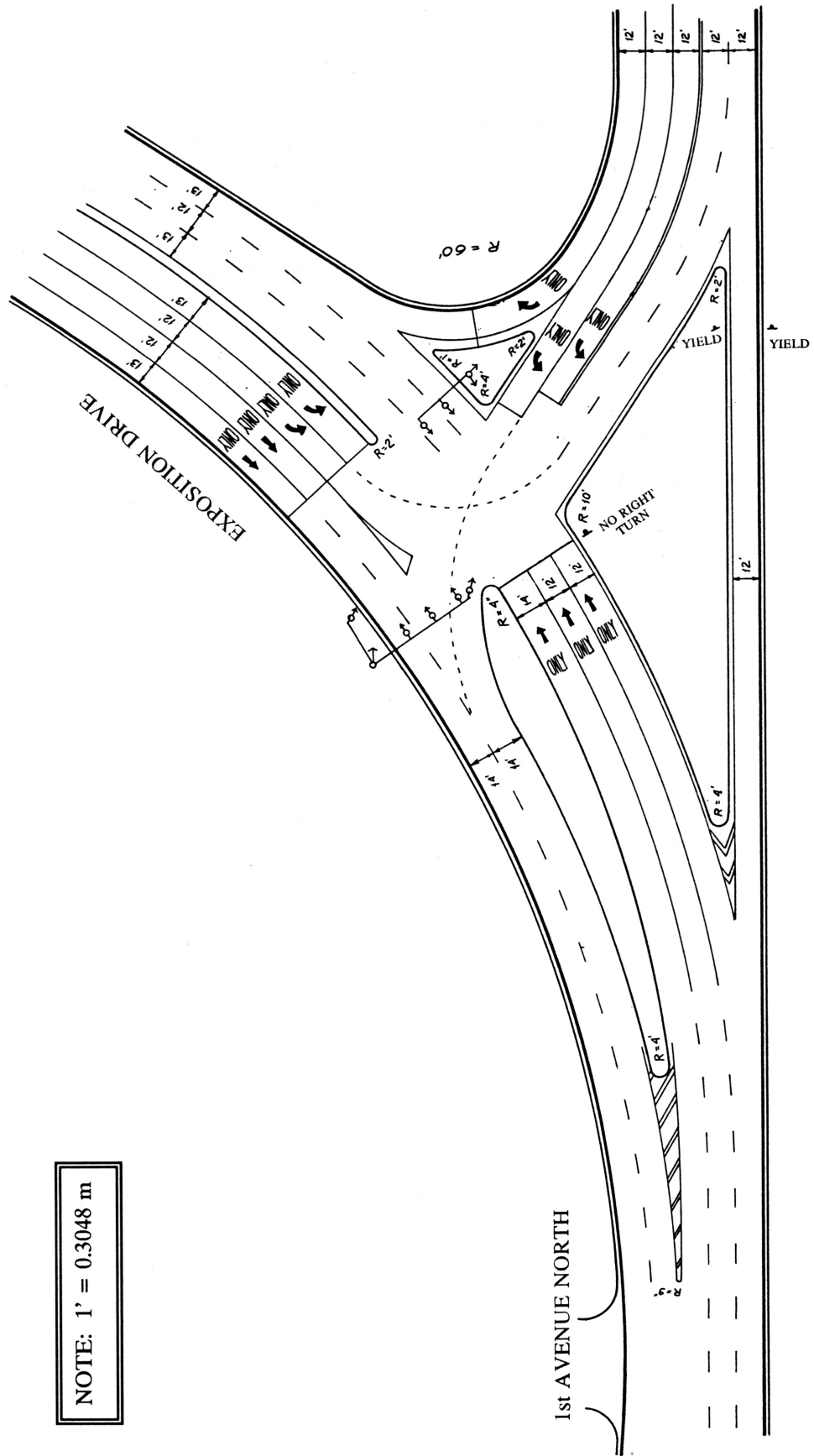

Source: Ref. 3.

**Fig. 18-4-Intersection in an urban Area**  
 First Avenue reoriented to meet Exposition Drive at about 90°.

### C. Channelization

1 **Definition.** "Channelization of at-grade intersections is the separation or regulation of conflicting traffic movements into definite paths of travel by the use of pavement markings, raised islands, or other suitable means, to facilitate the safe and orderly movement of both vehicles and pedestrians." (Ref. 5.)

2 **Purposes.** Intersection channelization is to:

- a. Separate conflicting movements – usually on intersection approaches.
- b. Reduce excessively large paved areas (example 3 a.).
- c. Control angles of conflicting movements (examples 3 b. and c.).
- d. Favor predominant turning movements (example 3 b.).
- e. Control speed (examples 3 b. and d.)
- f. Discourage prohibited movements (example 3 e. and Fig. 34-2E).
- g. Protect turning and crossing vehicles (example 3 f.).
- h. Eliminate prohibited movements (Fig. 34-2C, D, and F).
- i. Provide space for traffic control devices (example 3 g.).
- j. Protect pedestrians and reduce crossing distances between refuges.

3 **Design Principles.** The degree to which each of the following design principles may apply to a specific problem depends on the actual traffic and physical conditions. A principle may be modified in its application to a particular situation, but disregard of these principles may result in operational and/or safety problems.

- a. Reduce the area of conflict: large paved intersection areas invite unpredictable vehicle and pedestrian movements.

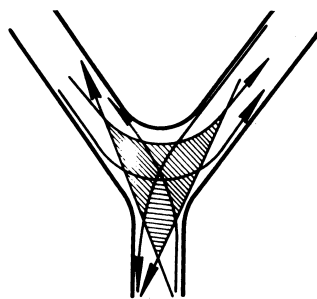

**Impact area of all paved intersection**

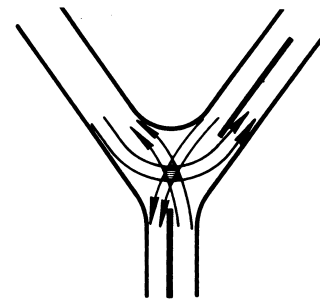

**Impact area of channelized intersection**

- b. When traffic streams cross without traffic signal control, the crossing should be made at or near right angles to reduce the potential impact areas and the time of crossing a conflicting traffic stream, and to provide the most favorable sight lines for drivers to judge relative positions and speeds of other vehicles. This treatment also reduces the speed of one of the conflicting traffic streams. Avoid bending the path of the major traffic stream if possible.

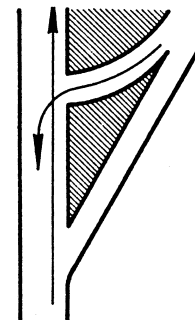
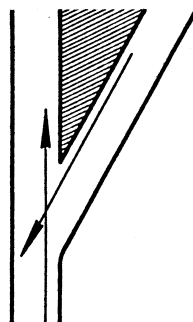

- c. Merge traffic streams at angles of  $10^\circ$  to  $15^\circ$  to permit traffic to flow together with minimum speed differentials. Drivers entering the major traffic flow may use relatively short gaps.

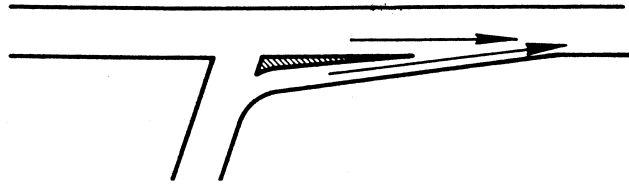

- d. Reduce the speed of traffic by funneling.

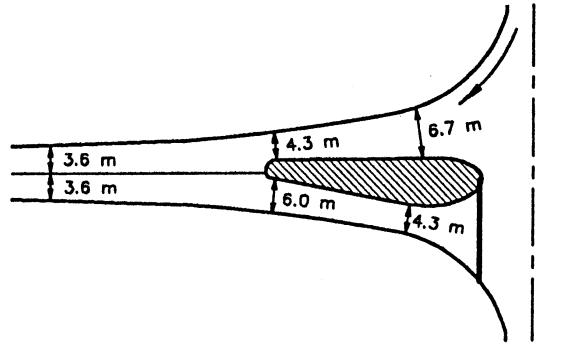

- e. Discourage prohibited turns by island placement and shape.

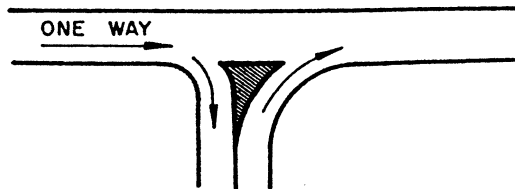

- f. Provide protection for vehicles about to turn or cross traffic streams. A refuge area between opposing traffic streams allows a driver to select a safe gap in one stream at a time.

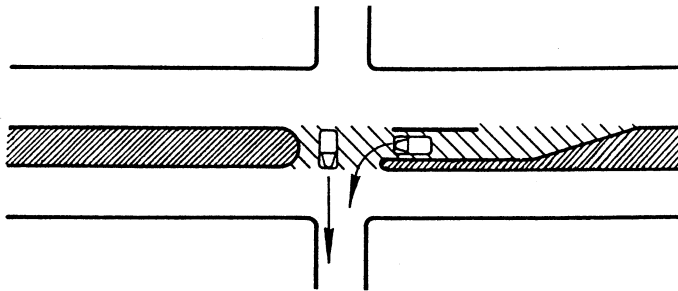

- g. Provide locations for the installation of necessary traffic control devices.

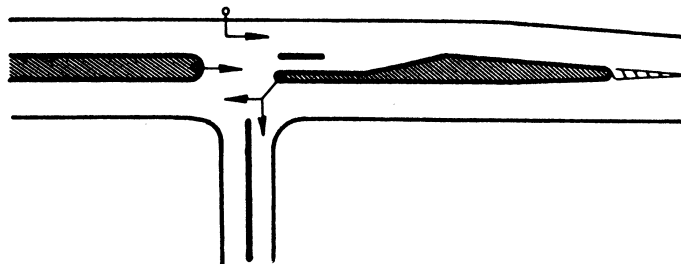

#### 4 Developing a Channelization Plan.

- a. Channelization is an art rather than a science. Every intersection requires a separate study because of turning movements, traffic and pedestrian volumes, physical dimensions, type of traffic control, etc.
- b. Planning begins with a condition diagram; a scale of 1:250 is desirable to show details. Several alternative island configurations are considered and compared. A choice is made between curbed, raised islands, and at-grade islands defined only by pavement marking.
- c. Channelization must accommodate turning movements by the facility's design vehicle. Ref. 2, pp. 21-41, provides detailed information on the path geometry of vehicle wheels. The approach end design of each island also requires special attention (see Ref. 8, Sec. 5D). It should guide vehicles in a normal path geometry, so that the island does not create an obstruction in the roadway.
- d. Signing and marking are intended to guide drivers and avoid confusion. Some otherwise acceptable layouts may be discarded because they cannot be clearly signed and marked.
- e. The final plan includes details of civil and electrical engineering features (drainage facilities, curbs, lighting, signals, etc.) required for the completion of the project. Ref. 5 includes examples of intersection channelization. Figs. 18-3 and 18-4 illustrate many of the principles cited above.

#### 5 Some Common Errors in Channelization.

- a. Channelization where it is not warranted by traffic conditions.
- b. Creation of small islands; an island should have a surface area of at least 5 m<sup>2</sup>.
- c. Use of more islands than necessary to accomplish objectives.
- d. Failure to eliminate conflicts of acute angles.
- e. Channelization where approach sight distances are inadequate; i.e., on curves and crests.
- f. Inadequate design of the approach end of islands.
- g. Geometric design inadequate to accommodate vehicle size and turning characteristics.
- h. Inadequate illumination and reflectorization.
- i. Failure to consider the need for future traffic signal requirements.
- j. Planting in islands too small for adequate maintenance. Small islands should be paved.

### D. Rotary Intersections and Roundabouts

Rotary intersections and roundabouts consist of a central circle surrounded by a one-way roadway. Approaches are channelized to turn traffic toward the right (diagram C.3.d. above). All conflicts that occur near right angles at normal intersections become weaving conflicts.

- 1 At *rotary intersections* in the U.S., normal right-of-way rules apply—i.e., yield to traffic from the right—in the absence of other controls. Rotary approaches may be controlled by STOP signs, YIELD signs, or traffic signals.
- 2 *Roundabouts* in many foreign countries and increasingly in the U. S. are unsignalized facilities at which entering traffic yields to traffic already within the roundabout. This control is indicated by a transverse pavement marking. When appropriate, roundabouts have significantly reduced urban intersection accidents (Ref. 6).
- 3 The *geometric elements* of a roundabout are shown in Fig. 18-5. Special features include the splitter island, which deflects approaching traffic to the right, the entrance and exit radii, and the central island circumscribed by a truck apron.

### E. Design of Interchanges

Interchanges are normally built between a freeway and a surface arterial or another freeway. However, they are sometimes built between two major non-access-controlled highways or streets. Ref. 7, a companion to Ref. 2, provides useful guidance for interchange geometric design.

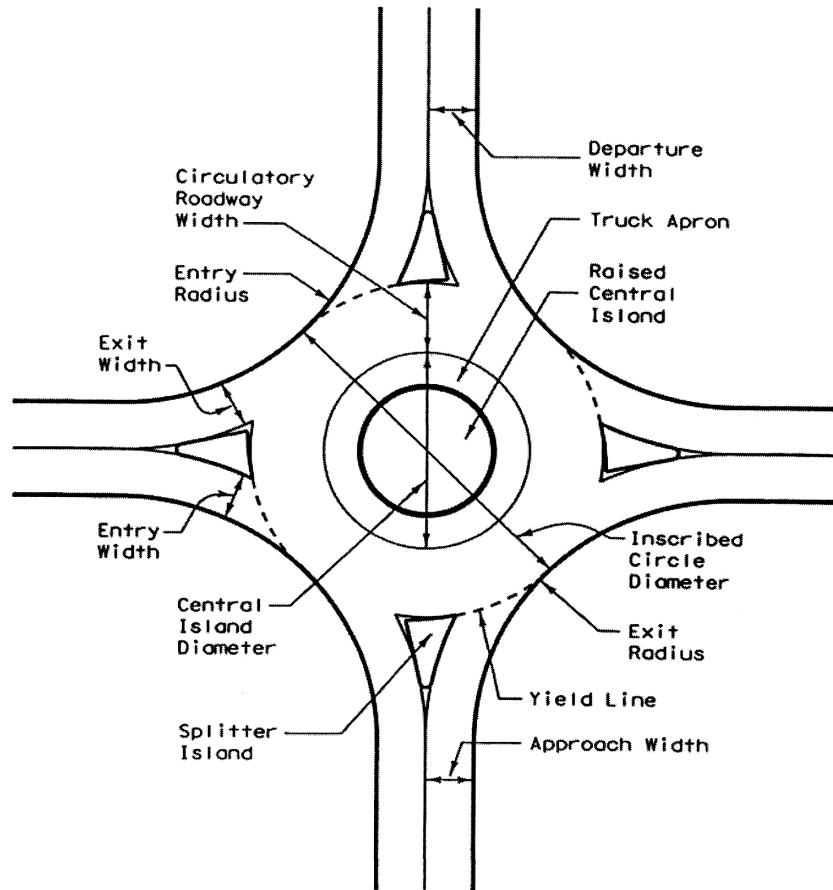

**Fig. 18-5 – Geometric Elements of a Single-Lane Modern Roundabout**

Source: *A Policy on Geometric Design of Highways and Streets*.  
 Copyright 2004 by the American Association of State Highway and  
 Transportation Officials, Washington, DC. Used by permission.

## 1 Types of Interchanges (Fig. 18-6).

- a. *Diamond*. This is the simplest and most common form of interchange between two highways. It requires little land and has only one point of entry and exit per direction on the freeway (Fig. 18-6a). This design can fail when both ramp exits are signalized and traffic volumes exiting the freeway are high.

Where frontage roads are provided, the ramps may merge into these rather than terminating at the cross street (Fig. 18-6b). Where the freeway crosses a pair of one-way streets, a "split" diamond (Fig. 18-6c) is often a good solution. (The figure shows a split diamond with frontage roads, but these are not required for good functioning of such an interchange.)

The *single-point diamond* (Fig. 18-6d) reduces the conflict points on the cross street to a single intersection above or below the freeway. Structural costs are increased, but street-level control is simplified.

- b. *Two-Quadrant Cloverleaf*. This is sometimes used as the first stage in the development of an ultimate four-quadrant cloverleaf, sometimes as a final design. It serves well where most traffic leaving one highway turns to the same leg of the intersecting highway. For instance, the example shown in Fig. 18-6e is used if the predominant movements are right turns from the freeway and left turns from the cross street; if left turns off the freeway and right turns off the cross street were more important, the other two quadrants would be built. The remaining intersecting conflicts on the cross street affect only the minor turning movements. They can be reduced by providing direct ramps for all right turns.

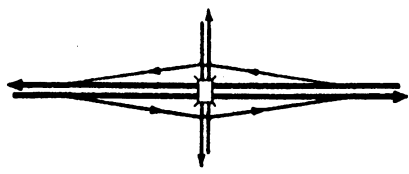

a. Diamond

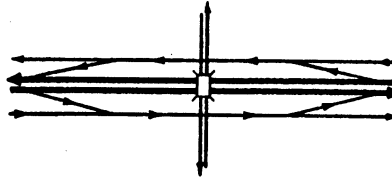

b. Diamond to Frontage Roads

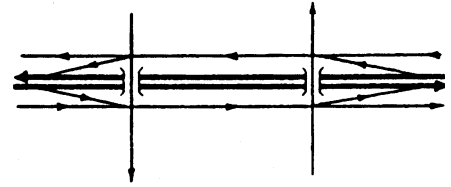

c. Pulled-Apart Diamond

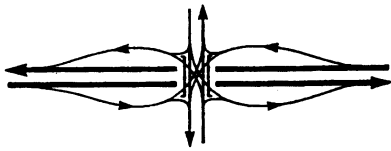

d. Single-Point Diamond

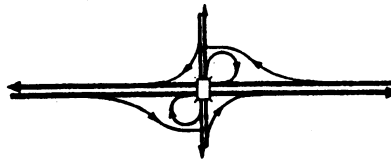

e. Half Cloverleaf with All Direct Right Turns

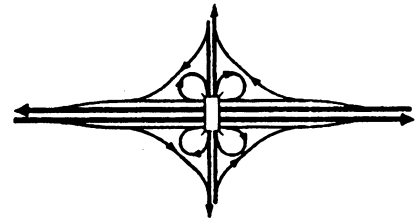

f. Full Cloverleaf with Collector Roads

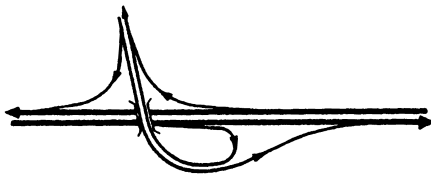

g. Trumpet

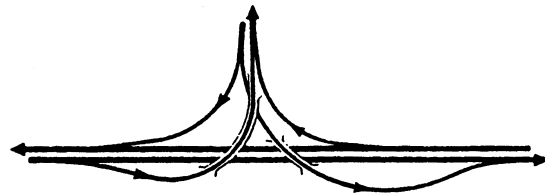

h. T-Interchange

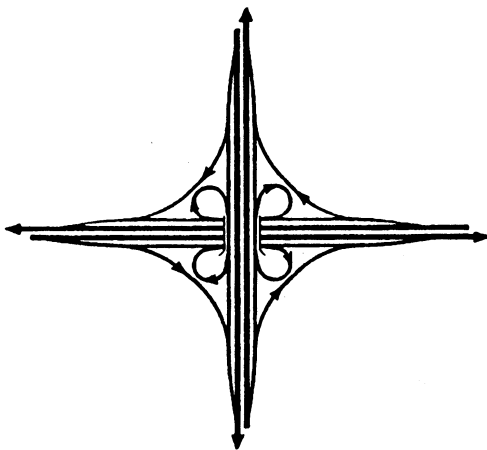

i. Freeway-to-Freeway Cloverleaf

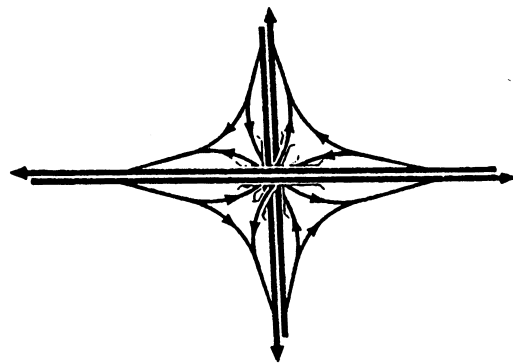

j. Direct Connection (4-level)

Fig. 18-6—Interchange Types

- c. *Four-Quadrant Cloverleaf*. This form of interchange eliminates all crossing conflicts found in the diamond but requires more area. In older versions of cloverleaves without collector-distributor roads (not shown), there are two points of entry and exit on each through roadway, and a weaving conflict between vehicles using the left-turn loops occurs where these enter and leave the through lanes. The proximity of the two exit points requires drivers to make two route choice decisions almost at once and makes destination signing difficult.

Provision of collector-distributor roads within the cloverleaf (Fig. 18-6f) moves the weaving and diverge-decision problems off the through lanes. Because there is only one point of exit on each through roadway, directional signing in the high-speed lanes is simplified. Although collector-distributor roads add to the cost of an interchange, requiring more land, more paving, and a longer separation structure, they are now the standard design. Where land values are very high and speeds relatively low, the collector-distributor road can be replaced by an auxiliary lane.

- d. *Trumpet*. This simple three-leg interchange (Fig. 18-6g) is used where a connecting highway terminates and where only a small amount of traffic moves between the terminating highway and one of the two legs of the freeway; the trumpet is laid out so that this minor traffic moves via the 270° loop.
- e. *"T" Interchange*. This corresponds to the trumpet, except that all turning movements are direct. It requires more structural work than the trumpet. An alternative design to that shown in Fig. 18-6h uses a single 3-level structure instead of several structures.
- f. *Freeway-to-Freeway Cloverleaf*. This is the standard cloverleaf with collector-distributor roads added on both intersecting facilities (Fig. 18-6i). A loop designed for 50 km/h increases the travel distance (in comparison with a direct left turn at grade) by 0.5 km. As Eq. [17-1] shows, the loop radius and distance traveled increase with the square of the design speed.
- g. *Direct Connection*. Where most or all interchanging traffic movements are large, direct connection designs are used. There are many forms, but all permit high-speed operation—270° loops are not used—and traffic leaves and joins the mainline on the right side. This interchange design requires a large number of structures unless a four-level structure (as in Fig. 18-6j) is used. Direct connection interchanges require less land than full cloverleaves.

2 **Interchange Design Elements**. These are described in Refs. 2, 3, and 7. Some features of special interest from the point of view of traffic flow and safety are:

- a. *Design Speed of Ramps*. Ideally, ramp design speeds would be the same as those of the freeway. This is often not feasible, especially for 270° loops. Table 18-1 gives a range of design speed values: right turns and direct connector ramps and longer ramps at diamond interchanges should be designed toward the upper end of these ranges. Loops and short ramps at diamonds may use design speeds at the lower end. Advisory speed signs must be used to alert approaching motorists where a low ramp design speed requires a warning.
- b. *Ramp Location*. Ramps should be placed on the right side of the roadway, so that merging and diverging maneuvers occur in the slowest of the through lanes. This is the lane in which trucks generally move, and in which motorists have learned to expect diverging and merging conflicts.

**Table 18-1—Guide Values for Ramp Design Speeds**

Highway design speed (km/h)	80	90	100	110	120
Ramp design speed (km/h)					
Upper end of range	70	80	90	100	110
Middle of range	60	60	70	80	90
Lower end of range	40	50	50	60	70

Source: Adapted from Ref. 2, Exhibit 10-56



Ramps leading off or onto the median lane should be avoided because they involve diverging or merging maneuvers in high-speed traffic, force trucks to weave across all intermediate lanes to or from the slow lane, violate driver expectancy, and require more extensive signing.

If operational problems (e.g., extensive weaving maneuvers) occur where an on-ramp enters the freeway in advance of an exit ramp, an auxiliary lane should be provided between the two ramp terminals. The effectiveness of the auxiliary lane and weaving capacity can be analyzed using capacity analysis procedures (see Chap. 8). In urban areas with high ramp volumes, collector-distributor roads may be needed to serve a series of ramp terminals, resulting in the equivalent of a dual roadway design.

At the city-street level, ramps must lead into and out of streets smoothly. To do this, provide one-way frontage roads (Fig. 18-6b and c). Extra ramp lanes may be needed so that traffic will not back up onto the freeway.

- c. *Speed-Change Lanes.* To transition from freeway speeds to ramp speeds or vice versa, speed-change lanes are used at the ramp terminals. Deceleration lanes are tapered toward the exit side at a small angle so that drivers need not reduce speed until they have fully cleared the through lane. Similarly, the taper used on an acceleration lane in the merge area permits drivers to enter the traffic flow on the freeway at freeway speeds. Various parts of Ref. 1 detail the design of speed-change lanes and the associated tapers.

The vertical alignment also affects smoothness of diverging and merging: an on-ramp on an upgrade makes it difficult for trucks to reach freeway speed; a downgrade off-ramp increases the amount of braking required. Both designs are strongly discouraged.

- d. *Diverging Points.* Each point where two traffic streams diverge requires the driver to decide which path to follow, and this decision requires knowledge based either on experience or adequate signing. It is therefore important that diverging points at interchanges be placed far enough apart so that the driver can deal with each one separately, and that the proper guide signs can be installed.
- e. *Bus Stops.* In many urban areas transit buses use freeways to offer express service. They generally make no stops on freeways, but stops may be needed at some interchanges to permit transferring with other transit routes or to serve adjacent areas. At diamond interchanges, such stops can be most conveniently made at the intersection of the ramps with the cross street. At other interchanges special bus lanes and stops may have to be provided so that buses will not have to follow circuitous routes off the freeway and to the next on-ramp. For suggested layouts, see Ref. 2, pp. 543-549.
- f. *Signing.* The design driver for interchange guide signing should be the motorist who is unfamiliar with the area. It is standard practice to sign rural interchanges at least 1.6 km ahead to allow drivers time for a decision. In urban areas, because off-ramps are spaced more closely, guide signs usually list the next three exits. Proper guide signing is also critical on streets leading to freeways, to ensure that motorists not only can find their way to the freeway but also will be going in the right direction once they are on it.

#### REFERENCES

1. JHK & Associates. *Design of Urban Streets*. Technology Sharing Report 80-204. Washington, DC: U.S. Department of Transportation. U.S. GPO. Jan. 1980, 438 p.
2. American Association of State Highway and Transportation Officials. *A Policy on Geometric Design of Highways and Streets*, 2004. Washington, DC: 2004.
3. California Department of Transportation. *Highway Design Manual*. Sacramento, CA: 2001 with 2004 revisions. Available at [www.dot.ca.gov/hq/oppd/hdm/hdmtoc.htm](http://www.dot.ca.gov/hq/oppd/hdm/hdmtoc.htm).
4. Harwood, D.W., et al. *Intersection Sight Distance*. Washington, DC: Transportation Research Board, NCHRP Report 383, 1996. 107 p.

5. Neuman, Timothy R. *Intersection Channelization Design Guide*. Washington, DC: Transportation Research Board. NCHRP Report 279, Nov. 1985. 153 p.
6. Jacquemart, G. *Modern Roundabout Practice in the United States*. Washington, DC: Transportation Research Board. NCHRP Synthesis 264, 1998. Available at: [http://trb.org/publications/nchrp/nchrp\\_sys\\_264.pdf](http://trb.org/publications/nchrp/nchrp_sys_264.pdf).
7. Leisch, J. And J. Mason. *Freeway and Interchange Geometric Design Handbook*. Institute of Transportation Engineers. 2005.

See also Chap. 17, Sec. A.



### A. Objectives of Intersection Control

- 1 **Utilization of Intersection Capacity.** The capacity of an intersection is almost always less than the sum of the capacities of the streets feeding into it. Where approach volumes are substantial, it is necessary to assign and apportion the right of way to the entering traffic streams by means of controls to maximize the use of the available capacity.
- 2 **Reduction of Accident Potential.** Intersections are points of conflict. Crossing, merging, and diverging of traffic streams are conducive to several types of accidents, especially right-angle collisions, sideswiping and opposite direction collisions involving a turning vehicle, and pedestrian accidents. Appropriate controls can reduce the probability of two vehicles or a vehicle and a pedestrian occupying the same space at the same time.
- 3 **Protection of Major Streets.** Traffic is encouraged to use major streets in accordance with an overall plan if it is given preferential right of way over cross traffic on minor streets.

### B. Right of Way Regulation

Right of way regulations are based on provisions of vehicle codes that prescribe the procedures to be followed by motorists when approaching and entering intersections.

- 1 **Uncontrolled Intersections.** The Uniform Vehicle Code (UVC - Ref. 1, § 11-401) sets forth the standard right of way rule: "When two vehicles approach or enter an intersection from different highways at approximately the same time, the driver of the vehicle on the left shall yield the right of way to the vehicle on the right." This rule does not automatically give the right of way to the driver of the vehicle on the right, who must be in full compliance with all applicable rules of the road before proceeding into the intersection. California Vehicle Code (CVC - Ref. 2, § 21800) is similar. The rule is modified in California for T intersections.
- 2 **Intersections Controlled by STOP or YIELD Signs.** These devices formally notify those drivers who are required to yield the right of way to intersecting traffic.
  - a. Motorists facing a STOP sign must stop at the marked stop line (or before entering the crosswalk or encroaching on the intersection). UVC § 11-403 and CVC § 21802 then require the driver to yield the right of way to any vehicle within the intersection or approaching it so closely as to constitute an immediate hazard. Drivers are also required to yield the right of way to pedestrians in the intersection's crosswalks. Similar meanings apply when a STOP sign is placed on the approach to a rail-highway grade crossing.
  - b. Motorists facing a YIELD sign must slow to a reasonable speed; a stop is required only if necessary to avoid conflict with vehicles or pedestrians on the intersecting street. If a driver passes a YIELD sign and is involved in a collision with an intersecting vehicle or pedestrian, it is prima facie evidence of the driver's failure to yield.

- 3 **Intersections Controlled by Traffic Signals.** The meanings of traffic signal indications and the actions permitted or required by drivers and pedestrians are given in UVC § 11-202 through 11-204 and CVC, § 21451-21457. The wording of these two documents is not identical, but the general meanings are the same. See also Sec. I.4.
- 4 **Left-Turning Vehicles.** Left-turning vehicles must yield the right of way to vehicles from the opposite direction that are approaching so closely as to constitute an immediate hazard and must continue to yield until it is safe to make the turn (UVC § 11-402, CVC § 21801).
- 5 **"Anti-Gridlock Rule."** UVC § 11-1112 and CVC § 22526 provide that, notwithstanding any traffic signal control indication to proceed, a vehicle shall not enter an intersection or marked crosswalk or railroad grade crossing unless there is sufficient space on the far side to accommodate it without blocking the passage of through vehicles or pedestrians from the cross street or track.

### C. Right of Way Control Methods

The most common methods of assigning the right of way at an intersection are discussed in this section.

- 1 **No Control.** In the absence of any of the controls mentioned below, the right of way regulation cited in Sec. B.1. applies.
- 2 **YIELD.** Cross traffic is merely required to yield, under the rules described in Sec. B.2. A yield sign is less restrictive for traffic on a minor street than a STOP sign, but does not provide the same degree of protection to traffic on the uncontrolled street. Ref. 3 lists some conditions under which the YIELD control is suitable. It is not an adequate protection for major streets or highways. YIELD signs should not be used unless the safe approach speed (see Sec. F) exceeds 15 km/h.

YIELD signs may also be required at the entrances to roundabouts in the U.S., because drivers in this country are not familiar with the right-of-way rules governing this type of intersection.

- 3 **Two-Way STOP.** The *MUTCD* (Ref. 3) recommends the use of STOP signs in the following situations:
  - a. At the intersection of a minor road with a major street or highway, to protect the right of way of traffic on the major facility.
  - b. Where reliance on the normal right of way rule (Sec. B.1.) is unduly hazardous, as indicated by high speeds, high accident experience, or restricted view of intersecting traffic. Prior to applying this "warrant," less restrictive measures (e.g., YIELD signs) should be considered.
  - c. At an unsignalized intersection in an area where most other intersections are signalized.

Where one of the streets at the intersection is obviously more heavily traveled or is a designated major highway, the STOP sign should be placed to control the traffic on the other street. Where two equally important streets intersect, the STOP sign should be placed to control the street with the minor flow, thus delaying the minimum number of vehicles. The STOP sign may not be accompanied by a contradictory message, such as RIGHT TURNS PERMITTED WITHOUT STOPPING. Traffic engineers should be wary of implementing 2-way stops at intersections with three approaches, or 3-way (or 1-way) stops at intersections with four approaches.

The STOP sign is normally placed at a point where it is readily seen by an approaching driver and (preferably) where the stopped driver has an adequate view of approaching traffic on the intersecting street. If the sight distance from this location is inadequate, a stop bar (Chap. 14, Sec. H.4.a) should be placed at a safe stopping position or the sight distance restriction should be removed. Field studies reported in Ref. 4 found that where sight distance is restricted, motorists will pull forward to a point where the front of their vehicle is 1.5-2.0 m from the edge of the traveled way.

STOP signs are also used at other than simple four-way intersections. Signs should be placed to stop as few vehicles as possible, and they should not be used for speed control.

- 4 **Multiway STOP.** It should never be necessary to stop more than half of the vehicles entering an intersection. Multiway stop control stops all vehicles, thereby increasing vehicle emissions, fuel consumption, and noise. According to the *MUTCD*, multiway stop control may be suitable:
  - a. As an interim measure, where traffic signals are warranted and urgently needed, but cannot yet be installed.
  - b. Where an accident problem susceptible to correction by multiway stop control exists, as evidenced by five or more reportable accidents in a 12-month period.
  - c. Where total vehicular traffic entering the intersection on the major street exceeds 300 veh/h during any 8 hours of an average day, and the combined vehicular, pedestrian, and bicycle volume crossing the major street averages over 200 units for the same 8 hours, with minor street vehicles experiencing an average delay of at least 30 s during the maximum hour. If the 85th percentile approach speed on the major street exceeds 65 km/h, 70% of these volumes will suffice.

Agencies have developed scoring systems to evaluate multiway STOP installations. For example, the City of San Diego has a procedure for arterial streets that assigns points based on the following:

- if both intersecting streets are arterials
  - the number of accidents susceptible to correction within the previous 12 months
  - the total entering volumes during the highest 4 hours of a typical day
  - the side street volume during the same 4 hours
  - the difference between major and side street volumes (small difference scores highest)
  - unusual site conditions, (e.g., school, fire station, playground, steep hill)
- 5 **Traffic Signals.** With the exception of major reconstruction, traffic signals are the most expensive form of intersection control. Design and implementation costs for intersection signalization start at about \$125,000; costs increase rapidly if the signal installation requires geometric design changes. As with all traffic control devices, appropriate studies and the exercise of informed engineering judgment should precede the approval of a traffic signal installation (see Part E.)
  - 6 **Police Officer Control.** Intersection control by police officers is too expensive to be utilized on a regular basis. However, their use is appropriate under the circumstances described in Chap. 3, Part F, including breakdown of signal control (e.g., power failure); temporary traffic peaks generated by places such as stadiums, race tracks, theaters, or shopping centers; unusually high traffic volumes due to traffic detours for special events such as parades or road construction; and unforeseen events and emergencies, such as accidents, broken water lines, fires, or police actions.

Overuse of intersection traffic control devices can have negative effects on road users and on adjacent properties, and imposes a maintenance responsibility on the highway agency. For these reasons, it is preferable to use the least restrictive form of control that is consistent with the classification of the intersecting streets, the volume of traffic, approach speeds, available sight distance, and the provision of adequate safety. This is especially true for low-volume urban intersections. Ref. 5 suggests warrants for traffic control at these locations.

## D. Planning for Traffic Signals

- 1 Traffic signals have negative, as well as positive, effects. The *MUTCD* (Ref. 3) attempts to quantify site attributes where traffic signal installation may produce, on the average, more advantages than disadvantages. Although these threshold criteria are described as "warrants," they are not legal requirements for the installation of a traffic signal.

- 2 Because traffic signals may increase vehicle delay and accident frequency, consideration must be given to alternatives that are less restrictive (and less expensive) than traffic signals. The *MUTCD* suggests the following potential alternatives:
  - a. Install warning signs on the major road approach.
  - b. Improve sight distance by relocating stop lines or clearing sight obstructions.
  - c. Encourage major street speed reduction by using edge lines to narrow the lane width.
  - d. Supplement STOP signs with flashing red beacons.
  - e. Install flashing yellow beacons on warning signs in advance of the STOP control.
  - f. Add a lane on the minor street to facilitate turning movements.
  - g. Revise intersection geometrics to channel movements.
  - h. If the location has a high percentage of nighttime crashes, install or improve roadway lighting.
  - i. Restrict left turns if alternate routes are available.
  - j. If conditions warrant, install a multiway STOP.
  - k. Install a roundabout intersection.
- 3 To make an informed judgment about the need for a traffic signal at a location, an engineering study should be conducted at the site. Although actual data needs vary with site conditions, the following data can be helpful in assessing the need for a traffic signal:
  - a. A count of the number of entering vehicles on each approach for at least 12 hours on an average day. These hours should account for the greatest percentage of the daily traffic volume.
  - b. A turning movement count for the two peak hours in both the morning and afternoon, with data recorded at 15-minute intervals. Vehicle classification data should be collected if the site has unusual volumes of commercial traffic or transit vehicles.
  - c. A pedestrian volume count for the morning and evening peak periods cited above. Supplementary counts may be needed for other periods with high pedestrian volumes. If there is substantial bicycle traffic, this should also be counted.
  - d. The posted or 85<sup>th</sup> percentile speed on the uncontrolled approaches.
  - e. A condition diagram showing the physical features at the site (see Fig. 9-6).
  - f. A collision diagram showing the accident experience for at least one year (see Fig. 9-7).
  - g. The following additional peak-period data may help in understanding the intersection:
    - (1) Vehicle delay on STOP-controlled approaches (see Chap. 7, Sec. F).
    - (2) Number and distribution of acceptable gaps in the major roadway traffic
    - (3) Minor road 85<sup>th</sup> percentile approach speed beyond the influence of the intersection
    - (4) Pedestrian (and bicycle) delay
- 4 Most terms employed in signal warrant descriptions are readily understood; however, a few deserve clarification. Additional definitions are given in Ref. 3, Part IV.A.
  - a. *Major street* is the intersecting roadway with the highest volume of vehicular traffic during an average day.
  - b. *Average day* is a typical weekday, normally Monday through Thursday when volumes are influenced by employment. In recreation or entertainment areas, the average day could be on the weekend. Holidays, seasonal shopping days, and other special event days are excluded.
  - c. *Peak hour*, for volume-counting purposes, is the four consecutive 15-minute periods with the highest traffic volume. It need not start at the beginning of the clock hour (e.g., 4 pm).
  - d. *Volume* normally refers to the total amount of traffic approaching the intersection; in some cases, the *MUTCD* includes pedestrians and bicycles. Right-turn vehicles may be discounted from the approach volume in those cases where they enter the major roadway with minimal conflict.

- e. *Number of approach lanes* requires an engineering judgment based on the physical and operational conditions. A single lane is obviously a one-lane approach. However, an approach with an exclusive left-turn lane and a combined through and right-turn lane or an approach with an exclusive right-turn lane and a combined through and left-turn lane is not necessarily a two-lane approach. If the traffic volume in the exclusive turn lane is minor, then the approach may be considered as one-lane. However, if the traffic volumes in the two lanes are approximately equal, the approach should be considered as two lane.

### E. Traffic Signal Warrants

The *MUTCD* provides seven standard warrants, or conditions, for traffic signals; an eighth warrant for school crossings is discussed in Chap. 20 paragraph F.2.c.(1). A traffic signal should not be installed unless one or more warrants are met. Sites that satisfy multiple signal warrants deserve a higher installation priority than those meeting just a single warrant. The satisfaction of a warrant does not in itself require the installation of a traffic signal.

- 1 **Eight-Hour Vehicular Volume.** The most common justification for the installation of a traffic signal is the volume of intersecting traffic: a high volume on both major and minor streets (minimum vehicular volume), or an even higher volume on the major street and a lesser volume on the minor street (interruption of continuous flow). The warrant requires that:
  - a. During any 8 hours of an average day, the traffic volumes on the major street and the higher-volume approach of the minor street must equal or exceed the volumes in the 100% columns of Table 19-1 for either condition A or condition B. The higher minor-street volume may arrive on one approach during some hours and on the opposite approach during other hours.
  - b. If the major-street 85<sup>th</sup> percentile speed exceeds 65 km/h or the intersection lies within a built-up area of an isolated community with a population less than 10,000, the volumes in the 70% columns of Table 19-1 may be used.
  - c. If a site has traffic volumes during any 8 hours that exceed those in the 80% columns of Table 19-1 for both condition A and condition B, a traffic signal should be considered. The 8 hours need not be the same for the two conditions.

**Table 19-1—Eight-hour Vehicular Volume**

		Condition A – Minimum Vehicular Volume							
Number of lanes for moving traffic on each approach		Vehicles per hour on major roadway (total of both approaches)				Vehicles per hour on higher-volume minor-roadway approach (one direction only)			
Major roadway	Minor roadway	100%	80%	70%	56%	100%	80%	70%	56%
1	1	500	400	350	280	150	120	105	84
2 or more	1	600	480	420	336	150	120	105	84
2 or more	2 or more	600	480	420	336	200	160	140	112
1	2 or more	500	400	350	280	200	160	140	112

  

		Condition B – Interruption of Continuous Traffic							
Number of lanes for moving traffic on each approach		Vehicles per hour on major roadway (total of both approaches)				Vehicles per hour on higher-volume minor-roadway approach (one direction only)			
Major roadway	Minor roadway	100%	80%	70%	56%	100%	80%	70%	56%
1	1	750	600	525	420	75	60	53	42
2 or more	1	900	720	630	504	75	60	53	42
2 or more	2 or more	900	720	630	504	100	80	70	56
1	2 or more	750	600	525	420	100	80	70	56

Source: Ref. 3.



- 2 **Four-Hour Vehicular Volume.** Certain locations will have traffic volumes that exceed those required for the eight-hour volume warrant, but do not maintain these volumes for a full 8 hours. This warrant is met when:
- During any 4 hours of an average day, traffic volumes on the major street and the higher-volume minor-street approach lie above the appropriate curve in Fig. 19-1A. The three curves are based on the number of approach lanes on the major and minor streets.
  - If the major-street 85<sup>th</sup> percentile speed exceeds 65 km/h or the intersection lies within a built-up area of an isolated community with a population less than 10,000, the volumes must lie above the appropriate curve in Fig. 19-1B.

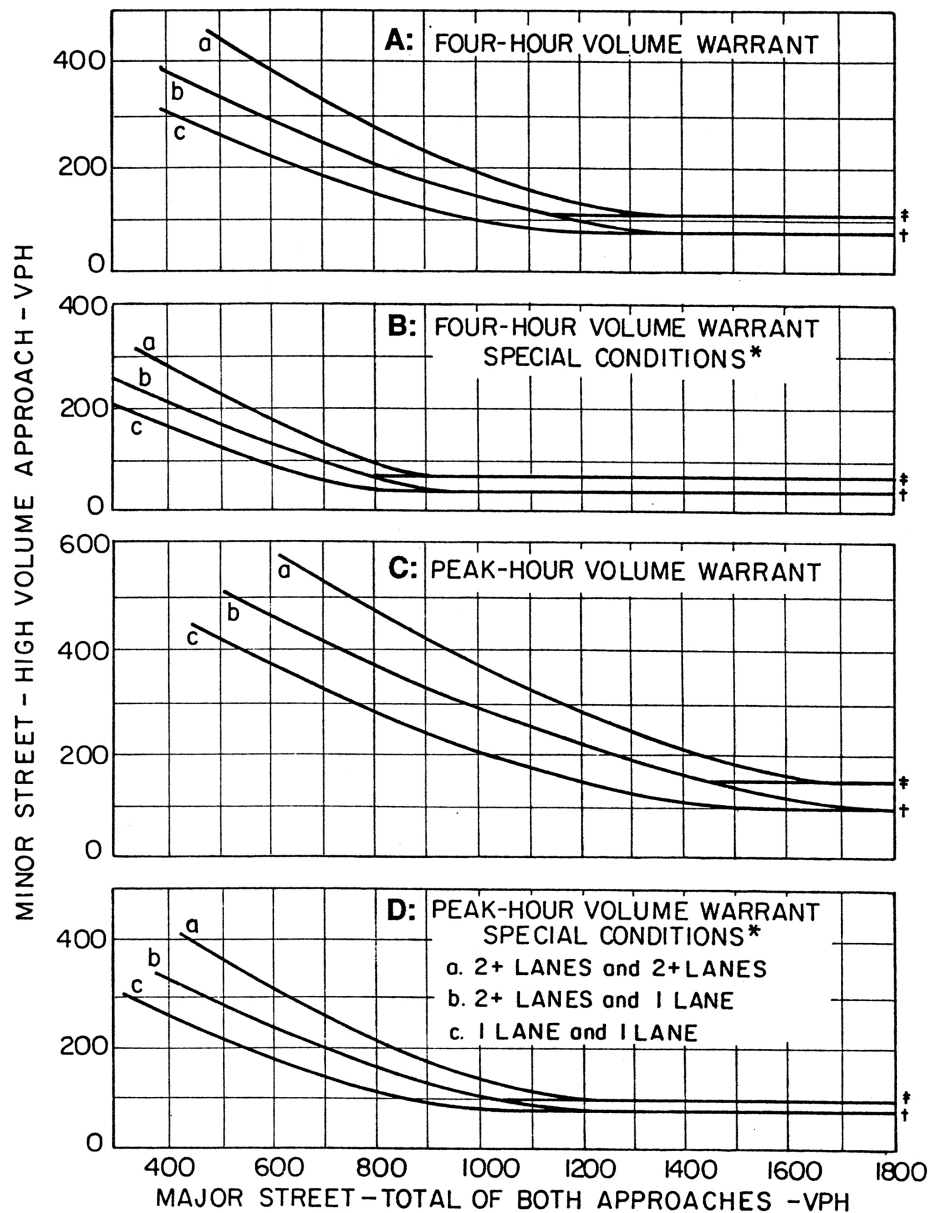

Source: Ref. 3.  
 \* - Where the 85th percentile speed exceeds 65 km/h, or at intersections in isolated communities of less than 10,000 population.  
 ‡ - Lower threshold volume for a minor street approach with 2+ lanes.  
 † - Lower threshold volume for a minor street approach with one lane.

**Fig. 19-1—Curves for Use with Signal Warrants 2 and 3.**

- 3 **Peak Hour.** This warrant is intended for unusual situations that are affected primarily by major employers who attract or discharge a large number of vehicles in a relatively short time period. The warrant may be satisfied in three ways:
- a. If these three conditions exist for the same one hour of an average day:
    - 1) The total delay experienced by vehicles on one minor-street approach exceeds 4 veh-h for a single-lane approach or 5 veh-h for a two-lane approach, and
    - 2) The traffic volume on the minor street approach exceeds 100 vph for one approach lane or 150 vph for two approach lanes, and
    - 3) The intersection's total approach volume exceeds 800 vph for a four-approach intersection or 650 vph for a three-approach intersection.
  - b. During the peak hour of an average day, traffic volumes on the major street and the higher-volume minor-street approach lie above the appropriate curve in Fig. 19-1C.
  - c. Under the speed and population criteria cited in Sec. E.2.b., the volumes lie above the appropriate curves in Fig. 19-1D.
- 4 **Pedestrian Volume.** Occasionally there are locations where vehicle volumes do not meet the threshold values given in warrants 1-3, but where pedestrian volumes and delay in crossing the major road are high. The pedestrian warrant is satisfied at intersections or mid-block locations where:
- a. Pedestrian volume crossing the major street during an average day exceeds 100 for each of any 4 hours or 190 during any peak hour; these volumes may be reduced by up to 50 percent when the predominant pedestrian speed is below 1 m/s.
  - b. There are less than 60 traffic-stream gaps per hour of adequate duration for pedestrians to cross during the hours in E.4.a.; for a major street with a median wide enough for pedestrians to wait safely, this requirement applies separately to each roadway.
  - c. There are no traffic signals within 90 m along the major street.
- Signals installed under this warrant should be pedestrian-actuated and should provide pedestrian indications.
- 5 **Coordinated Signal System.** One objective of traffic engineering is to provide smooth, continuous movement along arterials. The signal timing to provide this operation, particularly for one-way streets, is discussed in Chap. 16. However, platoons of traffic disperse about 0.5 km downstream of a traffic signal. Where uniform speed is desirable, and as signal spacing approaches 0.8 km, there is a need for intermediate traffic signals. In most cases, these intersections will not meet the other traffic signal warrants; to address public concerns about signal installation at "very minor intersections," thorough documentation must be maintained.
- 6 **Accident Experience.** In general, traffic signal installation increases the number of accidents but decreases their severity. Signals do not eliminate traffic accidents; indeed, the high-accident intersections in virtually all jurisdictions are already controlled by traffic signals. Conventional wisdom is that traffic signals reduce the frequency of (more severe) right-angle collisions while increasing the frequency of (less severe) rear-end collisions. With respect to right-angle collisions, however, this is only true for those minor-street motorists who actually stopped at the STOP sign; motorists who ignored the STOP sign could just as easily violate the signal indication. The *MUTCD's* traffic signal warrant has three criteria, all of which must be met to satisfy the warrant:
- a. Adequate trial of less restrictive remedies (see Sec. D.2) with satisfactory observance and enforcement has failed to reduce accident frequency.
  - b. Five or more reported accidents of types susceptible to correction by a signal occurred within a 12-month period. For ease and consistency in evaluating locations, calendar year analyses are preferable. Because of the inherent variability in accident frequency, accident experience over several years should be evaluated (see Chap. 9, Sec. E.2.).

Signals will not reduce rear-end collisions, sideswipes, or collisions between turning vehicles and pedestrians when both move during the same interval. They will also not reduce accidents caused by icy roads or by failure to observe traffic control devices.

- c. Vehicle volumes for eight hours exceed the 80% column of Condition A or B in Table 19-1, or 80% of the pedestrian volume requirements for warrant 4.

The accident experience warrant must be used very judiciously. As demonstrated in Chap. 9, accident experience at an intersection varies from year to year. It would be prudent to monitor traffic accident experience for two or three years before using this warrant to justify the installation of a traffic signal.

- 7 **Roadway Network.** In the interest of enticing traffic to concentrate on roads within a planned network, it may be useful to install traffic signals at the intersection of major routes that meet one or both of the following conditions:

- a. The total peak-hour entering traffic volume exceeds 1,000 vehicles on a typical weekday and the projected 5-year weekday volume satisfies warrant 1, 2, or 3.  
 b. The total existing or immediately projected volume exceeds 1,000 vehicles for each of any 5 hours on Saturdays or Sundays.

- 8 **Traffic Signal Removal.** The *MUTCD* specifies warrants (conditions) where the installation of traffic signals will probably do more good than harm. It makes sense, therefore, to assume that an intersection that previously satisfied these conditions, but which no longer meets them, should be evaluated for the possible removal of the traffic signal. In the 1980s, the Pennsylvania DOT mandated that local jurisdictions determine if their current signalized intersections continued to meet signal warrants. Philadelphia discovered that several hundred of its downtown intersections on one-way streets failed to meet the warrants. A subsequent analysis (Ref. 6) found that replacement of traffic signals with multiway stops resulted in a 24% reduction in crashes.

## F. Safe Approach Speed Calculation\*

In analyzing right-of-way control problems at intersections, it is often necessary to calculate the *safe approach speed*, the maximum speed at which traffic on one intersection approach can avoid colliding with cross traffic. It is a function of the speed of traffic on the intersecting street, the intersection geometry, and the location of view obstructions.

This method can be used for many intersections, including those where streets meet at an angle other than 90°. (It can also be applied to railroad grade crossings, where the "major street" is the track and "major street vehicle" is a train.) However, if there are horizontal or crest vertical curves in any of the approaches, a more detailed analysis must be performed.

Symbols used have the following meanings (see Fig. 19-2):

- L, R = major street vehicles approaching from the left and right, respectively  
 S = the side street vehicle  
 $C_L, C_R$  = the point where the paths of vehicles S and L, or S and R, cross respectively,  
 $d_L, d_R$  = the safe approach distances of L to  $C_L$  and of R to  $C_R$ , respectively, in m  
 $d_s, d_s'$  = the distance from vehicle S to  $C_L$  and  $C_R$ , respectively, in m  
 $T_{PR}$  = perception-response time of drivers (see Chap. 3, Sec. D.1.)  
 $U_L, U_R$  = 95<sup>th</sup> percentile speed of vehicles L and R, respectively, in km/h  
 $U_{sL}, U_{sR}'$  = safe approach speed for vehicle S with respect to vehicles L and R, respectively, in km/h  
 $w$  = deceleration rate in  $m/s^2$  (see Step 2 below for suggested values).

\* This method is adapted from a lecture by Dr. Alan Nicholson of the University of Canterbury, Christchurch, New Zealand.

Additional symbols are dimensions shown in Fig. 19-2. The following assumptions are made:

- The driver of a major street vehicle L or R initiates deceleration only if a side street vehicle S is perceived to be so close to the intersection that, given its approach speed, it could not stop before reaching the point where their paths cross.
- All vehicles are positioned laterally in the most dangerous legal location.

The analysis is first performed for one "side street" approach, then the other. If the two intersecting streets are of about equal importance, one is first designated the "side street" with the other being the "major street"; the analysis is then repeated with these labels reversed.

**Step 1:** In the field, measure  $a''$ ,  $b''$ ,  $\alpha''$ , and  $\beta''$ , which locate the view obstructions. (At the same time locate the view obstructions on all other corners for later analysis.) For  $a'$  and  $\alpha'$  (distances from the driver's eye to the edge of the roadway) assume a value of 3.6 m if parking is permitted and 1.8 m if it is prohibited; assume  $b'$  and  $\beta'$  to be half the street width plus 0.9 m for two-way approaches, 3 m for one-way approaches with parking along the left curb, and 1.2 m for one-way approaches with no left-side parking. The values of  $a$ ,  $b$ ,  $\alpha$ , and  $\beta$  are then readily calculated.

If streets do not meet at right angles,  $a''$ ,  $b''$ ,  $\alpha''$ , and  $\beta''$  are measured at right angles to the curb lines, and the acute angle of the intersecting streets ( $\theta$ ) is recorded.

There will be two paths for vehicle S approaching on the side street,  $b'$  m from the left roadway edge for analysis of conflicts with vehicle L approaching on the through street from the left, and  $\alpha'$  m from the right edge for similar analysis with vehicle R approaching from the right.

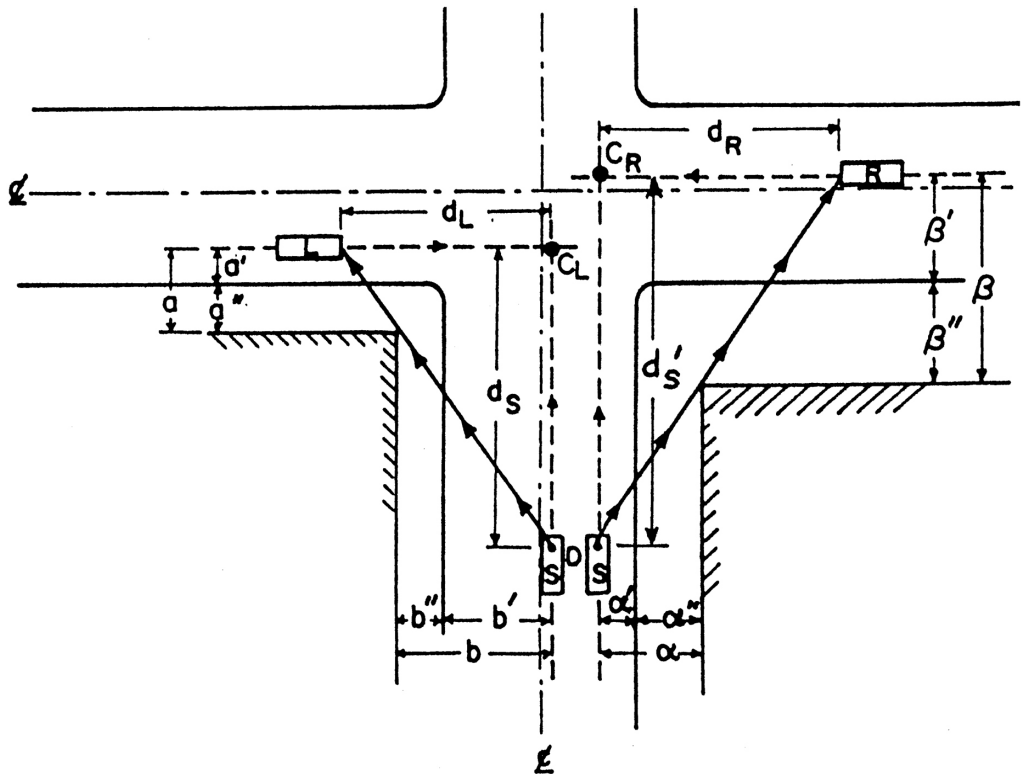

Fig. 19-2—Safe Approach Speed Diagram

**Step 2:** Determine  $U_L$  and  $U_R$ , the 95<sup>th</sup> percentile traffic speed on each through street approach. If this study is made for an intersection that has not yet been built, assume these speeds. Calculate the safe stopping distances from left and right, using Eq. 3.7a of Chap. 3:

$$d_l = 0.28 \bullet U_L \bullet T_{PR} + \frac{U_R^2}{25.9 \bullet w} \quad \text{and} \quad 0.28 \bullet U_R \bullet T_{PR} + \frac{U_L^2}{25.9 \bullet w} \quad [19.1]$$

For grades greater than  $\pm 3\%$ , multiply the result by  $(1 + G)$ , where  $G$  is the grade on the side street expressed as a decimal (uphill negative, downhill positive). Suggested values for  $w$  might range from 3 m/s<sup>2</sup> when the initial speed is about 40 km/h to 2.4 m/s<sup>2</sup> for an initial speed of about 100 km/h. However, local factors, including pavement conditions and likelihood of wet surfaces, should be taken into account.

[NOTE: If the intersection is not visible from the through street approaches at distance  $d_L$  or  $d_R$ , a potentially hazardous condition exists that may require advance warning signs and advisory speed plates on the major street approaches. In rare instances, a speed zone may be needed on the major street, in which case new values of  $U_L$  and  $U_R$  are used in this analysis.]

**Step 3:** Calculate  $d_s$ , the furthest distance of vehicle S from CL when its driver can see vehicle L at the latter's safe stopping distance from the potential point of conflict:

$$d_s = \frac{a \bullet d}{d_L - b} \quad [19.2]$$

For intersections where streets meet at an angle  $\neq 90^\circ$ , use:

$$d_s = \frac{a \bullet d_L / \sin \theta}{d_L - b / \sin \theta} \quad [19.3]$$

**Step 4:** Calculate the safe approach speed for vehicle S by solving:

$$U_s = 3.6 \bullet w \left( -T_{PR} + \sqrt{T_{PR}^2 + \frac{2 \bullet d_s}{w}} \right) \text{ km/h} \quad [19.4]$$

Again, values for  $w$  might be in the range of 2.4 to 3 m/s<sup>2</sup>.

**Step 5:** Repeat Step 3 to calculate  $d_s'$  and Step 4 to calculate  $U_s'$  for vehicle R, using  $\alpha$  and  $\beta$  instead of  $b$  and  $a$ , respectively. The lower of the two values,  $U_s$  or  $U_s'$ , is the safe approach speed for this approach.

**Step 6:** If necessary, repeat the procedure for other approaches.

## G. Turn Prohibitions

### 1 Purpose

- To eliminate conflicts with pedestrian movements by requiring turning vehicles to yield the right-of-way, in the process blocking the movement of vehicles behind them.
- To eliminate conflicts with oncoming traffic. Through traffic is often delayed behind such vehicles and the potential for rear-end collisions increases.
- To prohibit traffic from entering a one-way street in the wrong direction.
- To eliminate traffic taking short cuts through residential neighborhoods.

## 2 Application

- a. This is an inexpensive method for solving turning movement problems. However, other methods should not be overlooked: special turning lanes, separate signal phases, "scramble system", or elimination of some crosswalks.
- b. A turn prohibition compels drivers to seek alternate routes. This usually involves additional travel distance and, consequently, additional veh-km of travel. The prohibition of a turn at one intersection will often move the problem to another location. Hence, turn prohibitions should not be established until the replacement routes have been carefully analyzed.
- c. Turn prohibitions may be in effect continuously or only during peak periods. Observance is generally better if restrictions are permanent, because motorists will develop a habit of using alternate routes. Regulations that require drivers to assimilate additional information and then make decisions (No Left Turn, Mon-Fri, 4-6 pm, except Holidays) are more prone to wrong decisions. Better observance of peak-period restrictions may be obtained with real-time regulations; see G.3.b.

## 3 Devices

- a. *Regulatory Signs* are placed at the near right-hand corner of the intersection and, for left-turn prohibitions, also at the far left-hand corner. Overhead signs are occasionally used near the signal heads. The hours during which the restrictions apply must be shown where applicable.
- b. *Changeable Message Signs (CMS)* are more expensive, but hours when prohibitions are in force need not be shown on the sign, simplifying the message.
- c. *Traffic Signal Indication.* Turn prohibitions in effect at all times can be indicated by using arrows instead of circular lenses for the permitted movement (Ref. 3). However, if the authorized movements conflict with pedestrian streams crossing during the same interval, green arrows cannot be used.
- d. *Pavement Markings* may supplement turn prohibition signs or signals. They are especially suitable for left-turn prohibition on multilane roads because other vehicles may block regulatory signs from drivers in inside lanes.
- e. *Channelization* can be constructed in a manner that makes certain turning movements physically impossible. (See Chap. 18, Sec. C.) This method can be used only where the turn prohibition is in effect at all times.

## H. U-Turns

U-turns may have an adverse effect on capacity and safety, especially if the street is too narrow to permit the maneuver to be completed easily. The NO U-TURN sign can be used to prohibit this maneuver at problem locations. In some jurisdictions the prohibition may be established by local ordinance to cover entire business districts; however, this poses a challenge for the unfamiliar driver.

On major streets with continuous medians, U-turn opportunities should be provided for vehicles whose path would ordinarily involve left turns into and out of driveways or at blocked intersections (see I. 2. below). At signalized intersections with protected left-turn phasing and sufficient roadway width, U-turns can be permitted during the left-turn interval, although conflicts may arise with vehicles approaching from the left that receive a protected right-turn arrow indication at the same time.

## I. Special Turning Maneuvers

High turning-movement volumes at intersections often require special treatment. The following are among the ways of handling this situation:

- 1 **Multiple Turning Lanes.** Two or more lanes may be designated as turning lanes to the right or left. The lane on the outside of the turning movement may have optional turning (right or left turn permitted), but other lanes must have compulsory provisions (right or left turn only) to prevent vehicle conflicts. This control is usually indicated by overhead signs supplemented by pavement markings (see Chap. 14 Sec. F.1.e) or by curb-mounted signs for double right-turn lanes and median-mounted signs for double left-turn lanes. Pavement marking extensions (see Chap. 14, Sec. I.1.e) can be effective in conjunction with multiple turning lanes.
- 2 **Free Right Turn.** The right-turn movement may be separated from the rest of the traffic by means of channelization, and may be permitted to move continuously without regard for signs or signals controlling other traffic on the same approach. If the intersection is signalized, a green arrow, showing continuously, is sometimes displayed to the right-turn traffic. However, at intersections with substantial pedestrian traffic, free right-turn lanes must be designed with clearly marked cross-walks and related warning signs. YIELD sign control may be advisable if the angle of the intersection, the design of the acceleration lane, or other traffic or geometric conditions are problematic.
- 3 **Signal Phasing** (See also Ref. 7, Chap. 4).
  - a. *Three- and Four-Phase Cycles.* Turning movements may be accommodated by adding special phases during which opposing through traffic on the same street is stopped. The advantages gained by this must be weighed against the loss of green-to-cycle time and the concomitant loss in through traffic capacity caused by adding more phases to the cycle.
  - b. *Lead-Left and Lag-Left Turn Phasing.* To accommodate vehicles desiring to turn left, the beginning of the green interval for the opposing traffic stream may be delayed ("lead-left") or terminated early ("lag-left"). These left-turn phasing options are appropriate where the delayed traffic stream includes few vehicles seeking to turn left (e.g., at "T" intersections).
- 4 **Turning Movements on Red Signal Indication.**
  - a. *Right Turn on Red (RTOR).* The UVC and all state and Canadian provincial vehicle codes (except Quebec's) modify the meaning of a red signal indication to permit a motorist to make a right turn on red after coming to a full stop and yielding to vehicles and pedestrians, unless signs have been posted prohibiting this maneuver (Ref. 8). (However, RTOR is not permitted in New York City.) RTOR tends to increase capacity and reduce delays. Where special safety conditions (e.g., limited sight distance) warrant, signs prohibiting RTOR should be posted. The wording in Ref. 3 and proposed changes in Ref. 1 would limit the application of RTOR to "circular red indications;" RTOR would be prohibited for motorists facing a red arrow.
  - b. *Left Turn on Red (LTOR).* After a driver on a one-way street has made a full stop and yielded to vehicles and pedestrians, a left turn on red onto a one-way street is permitted (unless prohibited by a sign) in 40 states and 4 Canadian provinces; 4 additional states permit LTOR if a sign is posted authorizing the maneuver. A LTOR from a two-way street onto a one-way street, which creates no more conflict than RTOR, is allowed in Oregon, Washington, and British Columbia.

## J. Elimination of Major Conflicting Movements

The problems posed by an intersection can occasionally be solved only, or most satisfactorily, by eliminating the major conflicting movements.

- 1 **Grade Separation.** If the traffic demand through a major intersection increases beyond the level that can be handled by the most efficient traffic signal control, and if no alternative solutions, such as one-way streets, are feasible, major conflicts may be eliminated by a grade separation. A diamond interchange (see Chap. 18) is usually used, although single-point urban interchanges are becoming more common. The vertical alignment of one street is changed to pass over or under the other, but portions of this street remain to provide access to adjacent property at the existing grade line and to act as ramps for turning movements. The street whose profile is changed may have to be widened on at least one side. This solution is expensive.

- 2 **Partial or Complete Closure.** An intersection of a major highway with a local street may disrupt the efficiency of the former because of occasional crossing or turning movements. If traffic volumes on the local street are low, and if the street pattern provides alternate routes at little inconvenience to the minor street traffic, crossing and left-turn movements may be eliminated by building a continuous median across the intersection along the major street. Complete closing of one or more minor approaches to the intersection may be necessary if the right turns are also disruptive, or if the major street grade is being changed for a new grade separation nearby. See Chap. 33, Figs. 33-2E and F.
- 3 **Access Control.** Urban expressways and some arterials restrict driveway access and egress to "right-in" and "right-out" maneuvers. This significantly reduces conflict with through traffic.
- 4 **Rail-Highway Intersections.** Both closure and grade separation may be used effectively at these locations. As a result of these treatments, the number of rail-highway at-grade crossings has decreased in recent years.

#### REFERENCES

1. National Committee on Uniform Traffic Laws and Ordinances. *Uniform Vehicle Code*. Alexandria, VA. 2000. Information available at [www.ncutlo.org/ami\\_infor.html](http://www.ncutlo.org/ami_infor.html).
2. California Department of Motor Vehicles. *California Vehicle Code 2006*. Sacramento: January 2006 <http://www.dmv.ca.gov/pubs/vctop/vc/vc.htm>.
3. Federal Highway Administration. *Manual on Uniform Traffic Control Devices for Streets and Highways – 2003*, Rev 1. Washington, DC: 2004. <http://mutcd.fhwa.dot.gov/pdfs/2003r1/pdf-index.htm>.
4. Harwood, D.W., et al. *Intersection Sight Distance*. Washington, D.C.: Transportation Research Board, NCHRP Report 383, 1996. 107 p.
5. Box, Paul. "Warrants for Traffic Control Devices at Low-Volume Urban Intersections." *ITE Journal*, v. 65, n. 4, April 1995, pp. 32-43.
6. Persaud, B., et al. "Crash Reductions Related to Traffic Signal Removal in Philadelphia." *Accident Analysis and Prevention*, Vol. 29, No. 6, 1997.
7. Kell, J.H. and I.J. Fullerton. *Manual of Traffic Signal Design*. 2nd Ed. Englewood Cliffs, NJ: Prentice-Hall, 1998.
8. American Automobile Association. *Digest of Motor Laws*. Heathrow, FL: 66th Ed., 2000.





A. Introduction and Purpose

- 1 **Definition of a Pedestrian.** "Any person afoot" is the Uniform Vehicle Code's definition of a pedestrian. Twenty-three states concur in their vehicle codes; fifteen others, however, expand this definition to explicitly include people with disabilities, such as those who use wheelchairs or other mobility devices (Ref. 1).
- 2 **Background Information.** Streets, intersections, and sidewalks must be designed to meet the needs of pedestrians. Surveys have found that there are 56 million walking trips in the U.S. every day (7.2% of all trips). However, the actual number of non-motorized trips is likely much higher than reported (see Ref. 2; also Sec. D.2 in current chapter). In fact, one study found that 80% of the driving age public walked, ran, or jogged outdoors at least once per day during the summer months (Ref. 3).

Walking provides basic mobility to all people and can be especially important for low-income and/or disabled populations. People walk for many different reasons (Fig. 20-1). When asked why they don't walk more, reasons include having a disability or other health problems (25%), poor weather (22%), and being too busy (19%) (Ref. 3). The majority of pedestrian trips are 0.4 km or less, with 1.6 km generally being the most that people are willing to walk (Ref. 4).

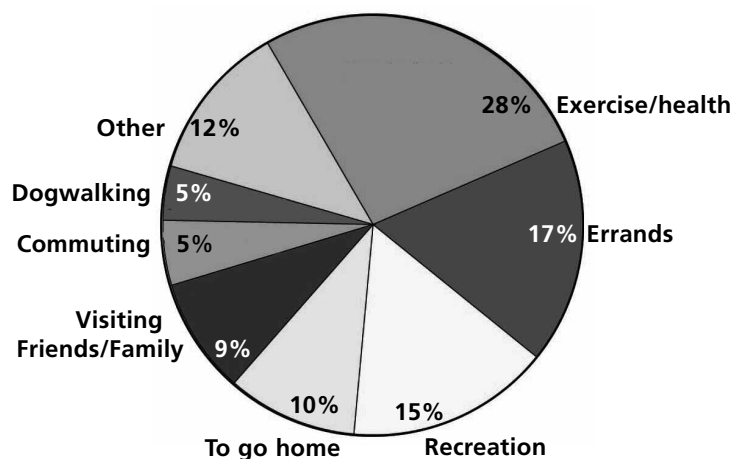
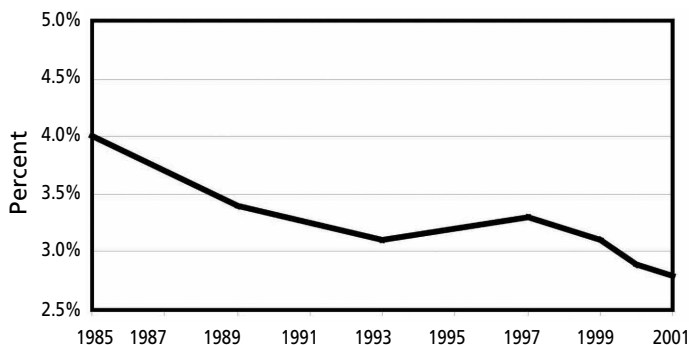

Fig. 20-1—Purpose of Walking Trips

While only a small percentage of people report walking as their primary mode of travel to work or identify themselves as "pedestrians," nearly all travel modes necessitate some amount of walking. Even if these multimodal walking trips do not cover great distances, and even

though the percentage of "pedestrian commuters" has declined (Fig. 20-2, adapted from Ref. 5), the fact that nearly everyone is a pedestrian at some point in each day has significant implications for how streets and sidewalks and even parking facilities need to be designed.

In 1990, the Federal Highway Administration (FHWA) described bicycling and walking as "the forgotten modes" of transportation. At the time an average of just \$2 million of federal transportation funds were spent each year for bicycle and pedestrian projects. In 1991, the passage of the Intermodal Surface Transportation Efficiency Act (ISTEA) marked the first time that pedestrian projects received more than negligible support from the Federal government (Ref. 6). In 1994, the National Bicycling and Walking Study prepared by the Department of Transportation for the Congress set a goal of doubling the percentage of total trips made by bicycling and walking (from 7.9% to 15.8%), while simultaneously reducing the number of bicyclists and pedestrians killed or injured in traffic crashes by 10%. In 2000, Federal funding for pedestrian projects was significantly greater than in 1990, but was still just 3% of the total roadway budget (Table 20-1). Between 1991 and 2001, the total number of walking and bicycling trips nearly doubled, but these modes still represented only 9.5 percent of all trips (Ref. 7).



**Fig. 20-2—Percentage of Commuters Walking to Work**  
**Table 20-1—U.S. Roadway Expenditures in 2000 (billions)**

	Total Roadway Spending	Funding for Walking	Percent for Walking
Federal	\$30.8	\$0.8	3%
State	\$66.4	\$0.7	1%
Local	\$31.3	\$3.1	10%
Totals	\$128.5	\$4.6	4%

Source: Ref. 8

- 3 **Pedestrian Laws.** Laws governing the rights and responsibilities of pedestrians vary by state. Many states use the exact wording or a variation of the Uniform Vehicle Code (UVC) in the language of their state vehicle codes. See Table 20-2 for some of the most common traffic laws related to pedestrians (Ref. 1).
- 4 **ADA Considerations.** The FHWA reports that there are approximately 43 million people in the U.S. with disabilities and that 85% of Americans living to their full life expectancy will eventually experience a permanent disability (Ref. 9).
  - a. *Americans with Disabilities Act (ADA).* The ADA, signed into law in 1990, specifically, guarantees that people with disabilities have full access to all public facilities throughout the U.S., including sidewalks and crosswalks. The United States Access Board ([www.access-board.gov](http://www.access-board.gov)) periodically updates the Americans with Disabilities Act Accessibility Guidelines (ADAAG) to include specific design requirements needed to fulfill the legal requirements of the ADA. Many jurisdictions develop their own set of design standards for pedestrians, which incorporate and/or exceed the minimums identified by ADAAG.

**Table 20-2—Uniform Vehicle Code Provisions Compared to State Vehicle Codes**

Code #	Law	Exact	Variant	None
UVC § 1-168	Definition of a pedestrian	23	19	8
UVC § 11- 501(a)	Pedestrian to obey traffic laws and devices	16	26	8
UVC § 11- 502(a)	Yield to pedestrian in crosswalk	13	33	4
UVC § 11- 503(a)	Pedestrian to yield when out of crosswalk	35	12	3
UVC § 11- 506(d)	Pedestrian in roadway shall yield	14	6	30
UVC § 11-801	Drivers not to exceed safe speed for conditions	5	41	4

b. *Engineering for people with different abilities* (adapted from Ref. 9).

- (1) *Mobility impairments.* People with mobility impairments need ramps instead of steps; have difficulty traveling on soft or uneven surfaces; and require additional space for maneuvering with assistive devices. These are the drivers for the bulk of ADA adaptations to the physical environment.
- (2) *Vision impairments.* People with vision impairments navigate by relying on their memories and on non-visual information such as sounds and textures. They can have trouble perceiving or reacting quickly to approaching dangers, obstacles, and changing conditions, especially in unfamiliar settings. Meeting their accessibility needs requires more complex adaptations to the physical environment, which can include "talking" signals and textured surfaces (see E.2.d.).
- (3) *Hearing impairments.* Generally public rights-of-way do not require much physical adaptation to be accessible for people with hearing loss. However, because they rely on visual cues alone, "blind" curves and other locations without good sight lines, can be troublesome.
- (4) *Cognitive deficiencies.* People with cognitive disabilities have difficulty finding their way in complex environments, understanding and reacting to signs or instructions, and making good travel decisions (such as when it is safe to cross a street). Adaptations for people with cognitive deficits (such as using signs with symbols instead of words) can also benefit children and others who do not read English well.
- (5) *Other special populations.*

*Age.* In 1999, children 15 and younger accounted for 12% of all pedestrian fatalities and 32% of all non-fatal pedestrian injuries (see Sec. F for more information about child pedestrians in the U.S.). People 65 and older accounted for 22% of all pedestrian deaths and approximately 8% of non-fatal pedestrian injuries (Ref. 10).

*Race and other socioeconomic factors* play a role in pedestrian safety. Compared to Caucasian pedestrians, the fatality rate for Latinos is 1.8 times higher; nearly twice as high for African-Americans; and close to three times as high for American Indians and Alaska Natives. African-American children have a pedestrian injury death rate almost twice that of Caucasian children (Ref. 11). Some of this difference can be ascribed to different walking conditions and amounts of walking. For instance, children in areas with high housing density and low socioeconomic status are more likely to suffer pedestrian injury (Ref. 11). In addition, African-Americans have been found to walk 82% more than Caucasians (Ref. 12).

- c. *Other benefits of ADA-compliant design.* Making public rights-of-way accessible benefits not only people with disabilities, but all users of a street or sidewalk. For instance, curb ramps can be used by people pushing baby strollers and carts as well as persons using walkers or wheelchairs. Streets and sidewalks designed to meet the needs of people with disabilities can also provide other benefits to communities, such as increased property values.

## B. Pedestrian Planning

1 **Characteristics of Pedestrian-Friendly Environments.** The quality of the walking environment is a function of a complex interaction of many elements, among them pedestrian orientation of adjacent land uses, the transportation infrastructure, climate, and topography. Table 20-3 provides a synopsis of these elements and their relative importance.

### 2 Community Planning.

- a. *Land Uses and Street Connectivity.* Traditional travel demand forecasting techniques are not sensitive to many of the attributes listed in Table 20-3, but these attributes can dramatically affect walking potential. They can also have noticeable effects on vehicular traffic by decreasing the number and length of vehicle trips. The Environmental Protection Agency (EPA) Smart Growth INDEX quantifies the effects of density, land use mix, and transportation system design on auto trip making. Some jurisdictions, have developed smart growth evaluation tools to assess whether private development proposals are consistent with smart growth principles.

**Table 20-3—Characteristics of Pedestrian-Friendly Environments**

Essentials	Highly Desirable	Nice to Have
<ul style="list-style-type: none"> <li>• Medium to high density land use</li> <li>• Mix of land uses</li> <li>• Street-oriented buildings (no more than 7.6 m from street edge)</li> <li>• Continuous sidewalks that are wide enough for couples</li> <li>• Dense development near transit</li> <li>• Transit routes every half-mile</li> <li>• Safe (lighted/well-marked, pedestrian signal heads, small corner radii, curb extensions, etc.)</li> <li>• Proper height to width ratio for street enclosures (1:1 to 1:3)</li> <li>• Short blocks (max 90-150 m)</li> <li>• Streets with 2 or 4 lanes</li> </ul>	<ul style="list-style-type: none"> <li>• Supportive commercial uses</li> <li>• Grid-like street networks (not cul-de-sacs or curvilinear streets) without steep slopes</li> <li>• Nearby parks and public spaces</li> <li>• Attractive transit facilities</li> <li>• Closely spaced street trees along access routes for visual appeal, shade, and visual/noise buffering</li> <li>• Little "dead space" (blank walls, parking lots, etc.)</li> <li>• Traffic calming</li> <li>• Shelter (shade awnings for hot weather/rain; and well-shoveled sidewalks and enclosed shelters for cold/snow)</li> <li>• Small-scale buildings or articulated larger ones</li> </ul>	<ul style="list-style-type: none"> <li>• Functional street furniture</li> <li>• Signs tailored to the viewer</li> <li>• Special pavement treatments</li> <li>• Uninterrupted building facades</li> <li>• Coherent, small-scale signage</li> <li>• Lovable objects, especially public art</li> </ul>

- b. *Density.* Increased land use densities enable more walking trips by creating shorter walking distances. Increased densities around transit stations, employment centers, and other major pedestrian attractions can be particularly effective.
- c. *Diversity.* Multiple land use types in close proximity to one another enables people to accomplish trips on foot. The land use mixes with the highest potential for intra-area walking trips are employment to/from shopping and residential to/from shopping.
- d. *Design.* Grid street systems, such as that shown in Fig. 20-3, generally permit shorter travel paths for vehicles and pedestrians, allowing pedestrians to reach more destinations.
- e. *Destination.* When considering new development, the location is just as important as the project itself. Placement of new development within existing built-up areas (in-fill) increases density of existing neighborhoods and allows the new development to take advantage of area-wide land use diversity.

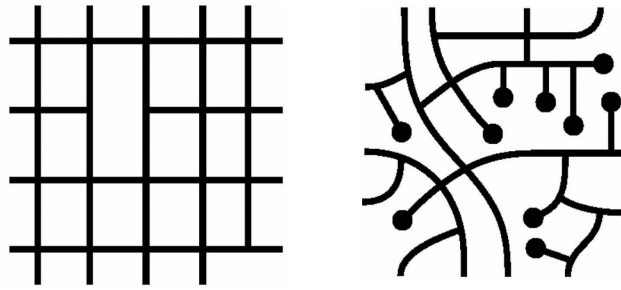

**Fig. 20-3—Street Layout Patterns**

- f. *Elements of successful pedestrian planning efforts* can be summarized by the acronym "PEDS."

**Planning and policies.** Planning efforts throughout a municipality (e.g., General Plans, project-specific site plans, etc.) must accommodate pedestrians. Pedestrian-friendly policies need to be adopted by legislators and administered by staff (i.e., zoning that supports mixed-use development and density near transit; streamlined environmental review for pedestrian, bicycle, and transit projects; plans for providing disabled access on public rights-of-way; etc.).

**Education, enforcement, and encouragement.** Successful education efforts are needed for multiple audiences: pedestrians (how to cross safely), drivers (laws for safe driving and for yielding to pedestrians), bicyclists (not to ride on sidewalks), municipal legislators and staff (how to write better laws and implement them), police (how to better enforce laws), and business owners/developers (how ped-friendly design can be profitable).

**Design guidelines.** Design standards need to meet the needs of pedestrians, such as guidelines for minimum sidewalk widths, curb ramps, bus bulbs, curb extensions, parking, corner radii, signals, and signage. (Pedestrian design is addressed later in this chapter.)

**Staffing, funding, and other resources.** Implementing plans and programs costs money and requires staff time, so locating resources is a key component of this process. Financing possibilities include: federal/state/regional government transportation funds, local discretionary and dedicated funds, business groups, nonprofit foundations, and funding sources for related interests (e.g., injury prevention/health promotion, economic development, public art, parks and trails, and special populations such as kids or seniors).

- 3 **Pedestrian Master Plans.** Pedestrian Master Plans are becoming more common in the United States. These plans are used to identify and prioritize infrastructure and policy changes that are needed to better meet the needs of pedestrians. They usually include an inventory of current walking conditions, identification of gaps and barriers in the pedestrian network, and a method for prioritizing, funding, and implementing new projects. While they can be expensive and time-consuming, they can also be very useful tools, especially for prioritizing projects in times of limited budgets. See Ref. 14 for more information about Pedestrian Master Plans.

### C. Pedestrian Collisions

In the United States, a pedestrian is injured every 8 minutes and killed every 113 minutes. Traffic collisions in the United States injured 68,000 pedestrians and killed 4,640 in 2004 according to NHTSA. These pedestrian fatalities most often occurred in normal weather (89%), at a non-intersection location (79%), in an urban area (72%), with a male pedestrian (69%), at night (66%), and along a two-lane roadway (60%) (Ref. 15).

- 1 **Enforcement.** Enforcement of existing pedestrian and traffic safety laws, as well as adoption of new and updated laws are a necessary component of a complete pedestrian safety program. Some low-cost components of increased enforcement are updating city ordinances, working with law enforcement to enhance the profile of pedestrian safety, increasing fines for viola-

tions of pedestrian safety laws, and implementing neighborhood traffic watch programs. Higher-cost programs usually involve increased staffing or installation of temporary or permanent equipment. Examples include organizing special operations to cite jaywalkers at problem intersections, installation of photo enforcement technology at intersections with a significant number of red light runners, deployment of portable speed-monitoring trailers to warn drivers at scattered locations of their excessive speeds, and the installation of permanent radar-equipped speed display signs.

- 2 **General statistics.** While walking trips only account for between 6% and 9% of all the trips made in the United States (Ref. 16), pedestrians account for a disproportionate share (11%) of all fatalities from motor vehicle crashes (Ref. 17). In some large urban areas, pedestrians can account for up to 40% to 50% of traffic fatalities (Ref. 10).

Long-term trends show a decline in pedestrian injuries and deaths from traffic collisions (Figs. 20-4, 20-5, Ref. 18). The decline in pedestrian injuries and fatalities follows a much larger, long-term nationwide trend for lower injuries/fatalities across most transportation modes. Much of the injury and fatality reduction may be attributed to a reduction in pedestrian exposure because fewer people are walking. It is difficult to speak of "collision rates" (such as the percent of pedestrian collisions per walking trip, distance traveled, or number of people walking) since there is very little pedestrian count data available (see Sec. D.2).

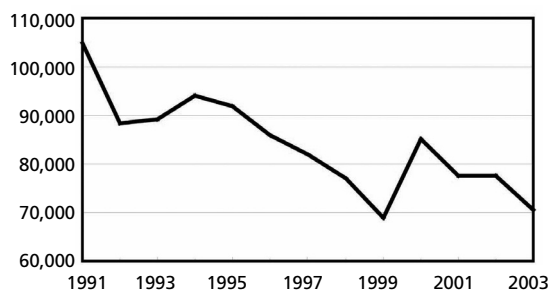

Fig. 20-4—Annual Pedestrian Injuries

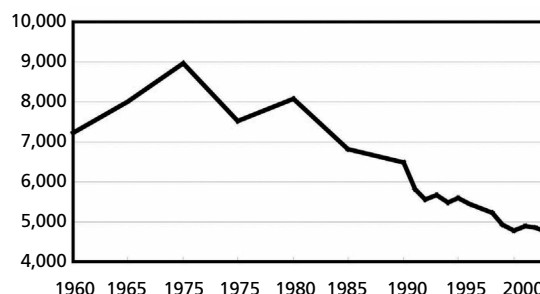

Fig. 20-5—Annual Pedestrian Fatalities

The declining rates of pedestrian injuries and fatalities, while a positive development, do not show the total picture in regards to pedestrian safety. For instance, overall collision data do not include data from pedestrian/motor vehicle collisions outside of a roadway (parking lots, driveways, etc.) nor the nearly 64% of reported pedestrian injuries that are non-collision slips or falls (Ref. 19). In addition, the actual number of pedestrian collisions is likely higher because collisions not resulting in monetary damage or injuries are not usually reported or may be miscategorized in crash reports.

3 **Collision factors.**

- a. *Crash types.* More than three-quarters of pedestrian crashes fall into six crash-type categories (Fig. 20-6). Better engineering can help reduce collisions caused by "at-fault" drivers and pedestrians (Table 20-4).

Table 20-4—Major Factors in Pedestrian Collisions

Pedestrian Factors		Driver Factors	
Improper crossing of roadway	29%	Inattentive	7%
Walking, playing, etc. in roadway	25%	Failure to yield right-of-way	7%
Failure to yield right-of-way	14%	Failure to keep in proper lane	6%
Darting or running into road	12%		

Source: Ref. 17

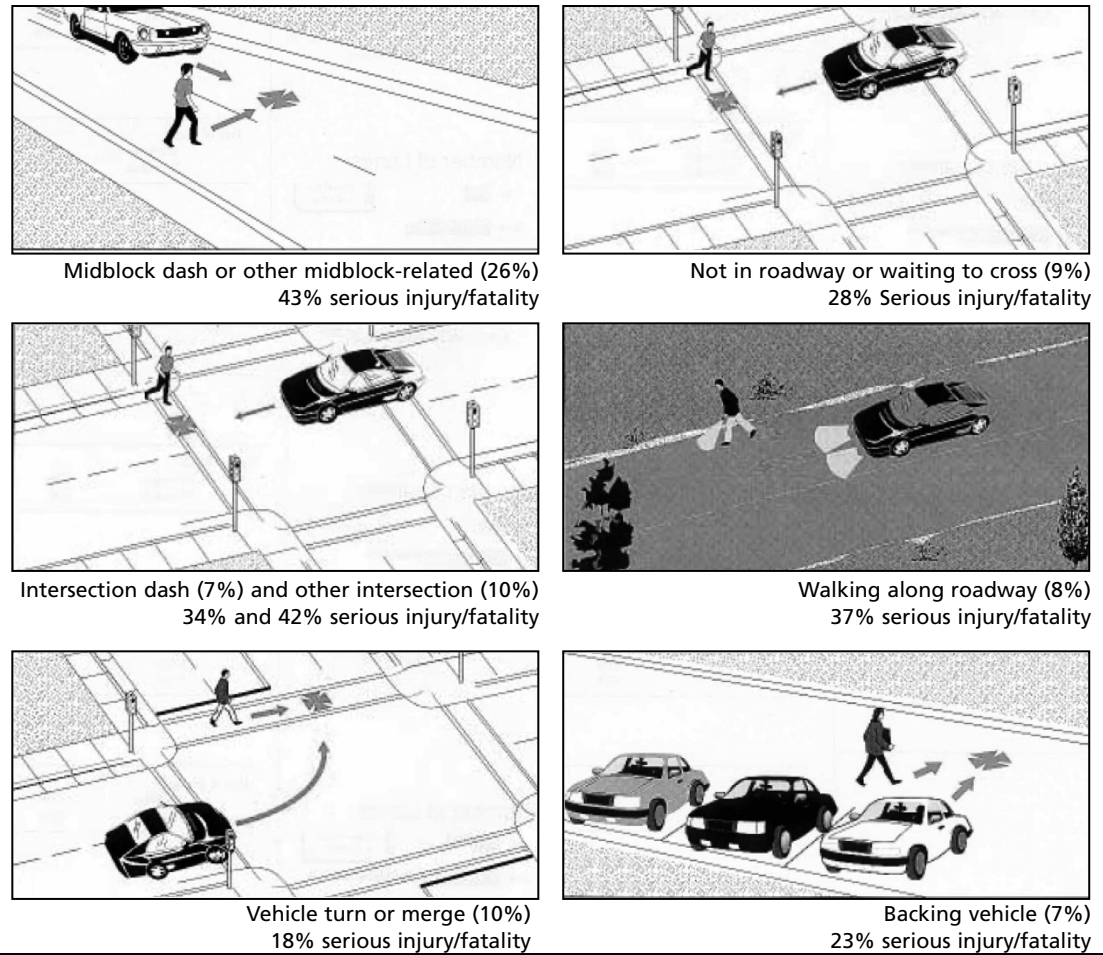

Source: Ref. 14.

**Fig. 20-6—Pedestrian Collision Crash Types**

- b. *Vehicular speed.* The fatality rate for pedestrians rises as motor vehicle speed increases (Fig. 20-7); pedestrians hit by vehicles going over 72 km/h are more likely to die than live (Ref. 20). Pedestrians struck by motor vehicles on the roadway had the highest rate of fractures and injuries to the head/intra-cranial, face, neck, abdomen/pelvis/lower back, in addition to other internal injuries (Ref. 19). They also suffered the greatest average number of injuries (2.3 injuries per collision with a motor vehicle in a roadway, 1.8 injuries per collision with one outside of a roadway, and 1.3 injuries in a pedestrian-only incident.)
- c. *Cone of vision.* As travel speed increases, the cone of vision of the driver decreases. Fig. 3-1 in Chap. 3 shows the reduction in what a driver can easily see as travel speed increases from 50 to 65 km/h. The focus of the driver's vision tightens on the roadway ahead, as objects along the side of the road fall into the background. This reduction in peripheral vision increases the chance that the driver will not recognize a pedestrian moving unexpectedly into the roadway early enough to avoid a collision.

**4 Pedestrian collision countermeasures.**

- a. *Resources for analyzing crashes and choosing countermeasures.* U.S. DOT's Pedestrian and Bicycle Crash Analysis Tool (PBCAT) is a free resource that helps engineers reconstruct crashes involving pedestrians and choose countermeasures (see Table 20-5) to prevent future crashes. U.S. DOT's *Safer Journey: Interactive Pedestrian Safety Awareness* CD features an interactive pedestrian crash type/countermeasure matrix with diagrams, explanatory text, and cost estimates for more than 60 recommended countermeasures (Ref. 21).



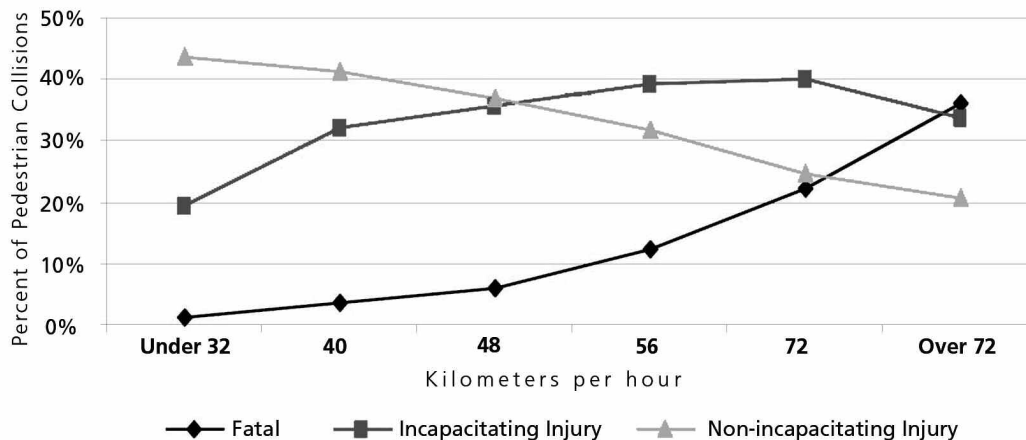

**Fig. 20-7—Pedestrian Injuries and Deaths by Auto Speed**

**Table 20-5—Pedestrian Crash Countermeasures**

Countermeasures	Common Pedestrian Crash Types					
	Along Road	Backing Vehicle	Intersection	Merging or Turning	Midblock	Not in Road
Crosswalks			✓	✓	✓	
Grade-Separated Crossings			✓	✓	✓	
Neighborhood Traffic Calming	✓		✓	✓	✓	✓
Pedestrian and Motorist Signing			✓	✓	✓	
Pedestrian Barriers			✓	✓	✓	
Pedestrian Refuge Islands			✓	✓	✓	
Pedestrian-Oriented Environments	✓	✓	✓	✓	✓	✓
Roadway Design	✓	✓	✓	✓	✓	
School Practices		✓	✓	✓	✓	
Sidewalks	✓	✓				✓
Signalization			✓	✓		

Source: Ref. 22.

b. *An example of site-specific analysis and countermeasure development.* A site-specific review of an intersection with the most pedestrian collisions in a particular city found that it had high ADT (30,000-50,000), free-right turn lanes with triangular islands at the corners to facilitate the free-right turn movement (example shown in Fig. 20-8), and nearby trip generators (transit stops and a high school). Potential low-cost improvements (less than \$5,000) included re-timing the pedestrian clearance interval for better ADA access, providing leading pedestrian intervals, and installing advance crosswalk limit lines and countdown pedestrian signals. Higher-cost items included reconstructing the triangular islands and providing two curb ramps at each corner.

**5 Comprehensive pedestrian collision analysis.** New GIS-based relational database applications can use standardized collision reports (e.g., state police crash records) to map and analyze pedestrian collisions on large scales (Fig. 20-9). Results can be displayed by location, col-

lision type, injuries/fatalities, time of year, weather conditions, alcohol involvement, and demographic information for involved individuals. Results can then be mapped and analyzed spatially, and/or analyzed for trends (e.g., the number of collisions at night). Comprehensive pedestrian safety initiatives can then be developed to mitigate any of the problematic collision trends or high-collision locations identified (Table 20-6). Initiatives should be assigned to lead agencies and evaluated for how much time and effort they will likely require and benefits they will produce.

## D. Pedestrian Flow

- 1 **Walking speed.** Based on research conducted in the early 1950s, an average "normal" walking speed of 1.2 m/s (4 ft/s) was first specified in the 1961 edition of the *MUTCD* (Ref. 23a), even though the original research also found that seniors moved more slowly [1.1 m/s (3.5 ft/s) at the 50th percentile and 0.9 m/s (3 ft/s) at the 15th percentile]. Other research (Ref. 24) found similar results. Indeed, many groups of pedestrians, including seniors, people with disabilities, and children, often have difficulty safely crossing streets that are timed to the 1.2 m/s walking speed.

In 2002, the Public Rights-of-Way Access Advisory Committee proposed a universal maximum walking speed of 0.9 m/s (3 ft/s), and that the entire street width plus the length of the curb ramp be used in calculating crossing distance. The 2003 *MUTCD* (Ref. 23b) recommends that pedestrians reach "at least the far side of the traveled way."

Currently (2005) the *MUTCD* Signal Technical Committee is considering two proposals: first, to lower the "normal" walking speed from 1.2 m/s to 1.1 m/s for crossing from curb to curb during the clearance (flashing "Don't Walk") phase to provide enough time for 85% of all walkers to make it across the intersection; second, to establish a 0.9 m/s minimum speed for crossing from the top of the curb ramp to the far curb during the total crossing time (walk phase plus flashing "Don't Walk" phase), which would ensure that 85% of the elderly and other slower walkers have enough time to cross (Table 20-7, and see Chap. 15 for timing calculations.)

A thorough engineering process for intersections and crossings considers other factors that might influence pedestrian crossing time at given locations, such as grades, cross slopes, and climate.

- 2 **Counts of walking trips/pedestrians.** After conducting a comprehensive review of existing pedestrian data, the U.S. Bureau of Transportation Statistics concluded that it is very important to increase the quantity and quality of pedestrian count data (Ref. 25). Mechanical pedestrian counting devices do not work well, and funding constraints often limit labor-intensive field surveying. Pedestrian data collection is also often hampered by the lower priority walking receives compared to other modes.

Transportation studies often tend to underestimate walking trips by counting only walk-to-work trips, leaving out trips by unemployed individuals and trips for non-work reasons, e.g., education, errands, recreation, exercise. In fact, only 5% of all walking trips are for commuting to and from work (see Sec. A.2 above). Studies also often count only trips made by "primary" modes of transportation, which omits walking trips that connect with transit or a car. Actual numbers of walking trips may be six times higher than what is found in conventional transportation studies (Ref. 2).

Two resources on the conduct of pedestrian counts, San Francisco Metropolitan Transportation Commission's *Handbook for Bicyclist and Pedestrian Counts* and FHWA's *Guidebook on Methods to Estimate Non-Motorized Travel*, are available for free download (Ref. 26).

ITE's Pedestrian and Bicycle Council is undertaking a nationwide study to standardize, collect, and analyze pedestrian and bicycle count data. New technologies for counting pedestrians (such as video imaging, infrared sensors, aerial photography, and GPS-based applications) may help build the level and quality of pedestrian count data in the near future (Ref. 28).



**Fig. 20-8—Example of an Intersection for Site-Specific Analysis**

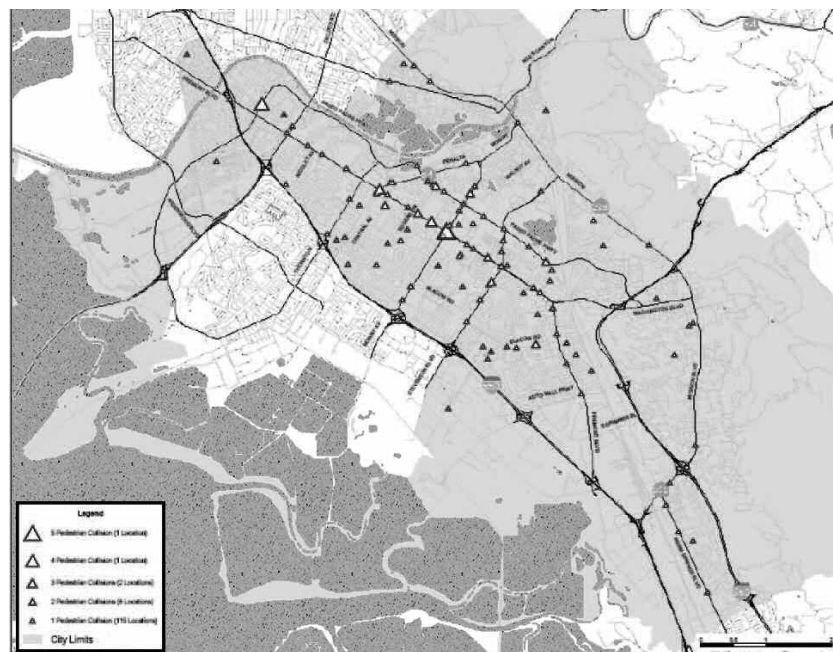

**Fig. 20-9—Example of a Pedestrian Collision Analysis**

**Table 20-6—Example of Pedestrian Safety Initiatives**

Pedestrian Safety Initiatives	Lead Dept.	Expected Benefit	Level of Effort	Time Frame
Adopt a formal pedestrian safety program	Engineering	High	High	Medium
Create a Safe Routes to School Program Choose countermeasures for high-collision locations Initiate traffic calming program	Engineering	High	Medium	Short
Create Pedestrian Advisory Committee work program	Engineering	High	Low	Short
Designate a pedestrian coordinator	Engineering	High	Low	Medium
Modify city-wide design guidelines Modify transportation impact study requirements Standardize pedestrian count methodology	Engineering	Medium	Low	Short
Prepare a plan review checklist	Engineering	Low	Low	Short
Revise Level of Service guidelines	Engineering	Low	Low	Medium
Develop/adopt a pedestrian master plan	Engineering & Planning	High	High	Medium
Establish policies/programs for crosswalk review	Engineering & Planning	Medium	Medium	Medium
Implement a crosswalk sting detail	Police	Medium	Medium	Medium
Revise pedestrian safety educational materials	Planning	Low	Medium	Medium
Write report on pedestrian conditions	Engineering	High	Medium	Short

**Table 20-7—Pedestrian Clearance Times and Total Minimum Times**

Street Width	Clearance Times for Various Walking Speeds; for Total Minimum Times add 4.0 s			0.9 m/s Total Pedestrian Time* Minus 1.1 m/s Clearance Time = Walk
	1.2 m/s	1.1 m/s	0.9 m/s	
12 m	10.0 s	11.4 s	13.3 s	15.4 - 11.4 = 4.0 s
18 m	15.0 s	17.1 s	20.0 s	22.0 - 17.1 = 4.9 s
24 m	20.0 s	22.9 s	26.7 s	28.7 - 22.9 = 5.8 s
30 m	25.0 s	28.6 s	33.3 s	35.3 - 28.6 = 6.8 s
36 m	30.0 s	34.3 s	40.0 s	42.0 - 34.3 = 7.7 s

\* - Based on street width plus assumed ramp lengths of 1.8 m

Source: Ref. 24.

**3 Demand forecasting.** Tools for forecasting pedestrian demand are not as robust as those for forecasting motor vehicle travel demand. Basing forecasts on current pedestrian counts alone does not usually work because there is not enough reliable or widely applicable data on how specific changes to walking conditions (such as adding a pedestrian-only plaza or fixing gaps in a "safe routes to school" network) affect future pedestrian activity. To date, there is not yet a clear consensus for an "ideal" pedestrian demand forecasting methodology (see Table 20-8). While some agencies are attempting to incorporate pedestrians into existing traditional four-step, vehicle-based traffic models, some smaller agencies are using aggregate models or simplified four-step models to determine high-use zones within cities or regions. The FHWA's *Guidebook* (Ref. 27) outlines 11 methods for modeling pedestrian activity, including qualitative assessments of each method's ease of use, data requirements, accuracy, sensitivity to design factors, and range of use .

#### 4 Levels of service (LOS).

- a. *Pedestrian LOS.* The *Highway Capacity Manual* (HCM - Ref. 28) uses pedestrian space as the primary measure of effectiveness (Fig. 20-10), with mean speed and flow rates as secondary measures (Ref. 29). Specific LOS formulas (Tables 20-9 and 20-10) are given for stairways, cross-flows, shared pedestrian-bicycle facilities and both signalized and unsignalized intersections. The physical conditions at street corners contribute a great deal to the

pedestrian LOS at intersections. Provision of adequate space for both moving and queuing pedestrian flows is necessary to ensure a good LOS. Signal phasing that keeps the crosswalks clear of autos also improves pedestrian LOS.

Alternative pedestrian level of service methodologies are under development that consider pedestrian comfort (good pathway surface, shaded in hot climates), convenience (route connects major attractors), perception of safety and security (no blind corners, visible from the street), and the economy of the pedestrian pathway (does it run along the shortest route, or are there signs of pedestrians creating short-cuts?).

The Florida Department of Transportation utilizes a model that predicts pedestrian level of service, using safety and comfort factors. The factors include the separation between pedestrians and traffic and the mix, volume, and speed of vehicular traffic. This type of analysis moves away from the traditional LOS, which shares much in common with vehicular LOS. Alternative LOS measurements consider specific constraints to pedestrian flow, such as stairways (Table 20-9) and wait time to cross roadways (Table 20-10).

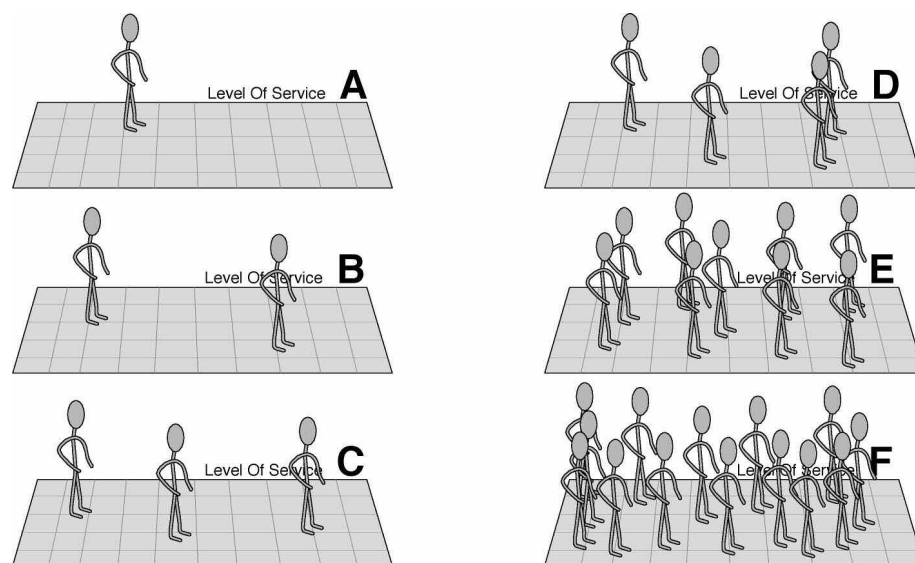

**Figure 20-10—Traditional Pedestrian Levels of Service**

The League of Illinois Bicyclists has developed a PedBike LOS calculator (Ref. 30), which utilizes a simple analysis of a roadway's cross-section and traffic characteristics to return a pedestrian and bicyclist LOS. Factors in the LOS calculation include lane width, pavement condition, traffic characteristics, and other easily identifiable conditions.

- b. *Multimodal LOS.* Multimodal LOS aids in the engineering of a more efficient travel environment by recognizing the differences in the travel characteristics of people traveling in motor vehicles and pedestrians (and bicyclists). While travel speed is a strong factor in vehicular LOS, an animated sidewalk lined with shops and cafes will often be perceived as a better pedestrian environment, even though the activity leads to slower pedestrian travel speeds. A wide street in an industrial park may have a good vehicular LOS, but pedestrians will likely avoid walking in the same area due to the lack of activity.

Once multimodal analyses techniques are available, they provide the opportunity to consider mode-preferential street types. For streets with primarily an auto carrying function, e.g., streets in industrial area, it may be appropriate to promote the movement of traffic and maintain high (better) LOS objectives. For other streets, such as main streets, it may be appropriate to permit a higher level of vehicular congestion in order to achieve higher service levels for pedestrians. For cities with major transit networks, transit preferential streets may also be appropriate.

**Table 20-8—Categories of Pedestrian Demand Forecasting Models**

<b>Purpose</b>	<b>Method</b>	<b>Description</b>
<p><i>Demand Estimation</i></p> <p>Methods that can be used to derive quantitative estimates of demand</p>	<b>Comparison Studies</b>	Aggregate-level methods that predict non-motorized travel on a facility by comparing it to usage and to surrounding population and land use characteristics of other similar facilities.
	<b>Aggregate Behavior Studies</b>	Aggregate-level methods that relate non-motorized travel in an area to its local population, land use, and other characteristics, usually through regression analysis.
	<b>Sketch Plan Methods</b>	Aggregate-level methods that predict non-motorized travel on a facility or in an area based on "back-of-the-envelope" calculations and rules of thumb about travel behavior.
	<b>Discrete Choice Models</b>	Disaggregate-level models that predict an individual's travel decisions based on characteristics of the alternatives available to him or her.
	<b>Regional Travel Models</b>	Integrated models of various aspects of travel behavior, set within an overall spatial framework which includes land use characteristics and transportation networks.
<p><i>Relative Demand Potential</i></p> <p>Methods that do not predict actual demand levels, but which can be used to assess potential demand for or relative levels of non-motorized travel.</p>	<b>Market Analysis</b>	Methods that identify a likely or maximum number of bicycle or pedestrian trips that may be expected given an ideal network of facilities.
	<b>Facility Demand Potential</b>	Methods that use local population and land use characteristics to prioritize projects based on their relative potential for use.
<p><i>Supply Quality Analysis</i></p> <p>Methods that describe the quality of non-motorized facilities ("supply") rather than the demand for such facilities. These may be useful for estimating demand if demand can be related to the quality of available facilities.</p>	<b>Bicycle and Pedestrian Compatibility Measures</b>	Measures that relate characteristics of a specific facility such as safety to its overall attractiveness for bicycling or walking.
	<b>Environment Factors</b>	Measures of facility and environment characteristics at the area level that describe how attractive the area is to bicycling or walking.
<p><i>Supporting Tools and Techniques</i></p> <p>Analytical methods to support demand forecasting.</p>	<b>Geographic Information Systems</b>	Emerging information management tools, with graphic or pictorial display capabilities, that can be used in many ways to evaluate both potential demand and supply quality.
	<b>Preference Surveys</b>	Survey techniques that can be used on their own to determine qualitative factors that influence demand, and that also serve as the foundation for quantitative forecasting methods such as discrete choice modeling.

Source: Ref. 27

**Table 20-9—Pedestrian Flow Characteristics on Walkways and Stairs**

	LEVEL OF SERVICE					
	A	B	C	D	E	F
	Flow Rate (ped/min/m)					
Walkways	<16	16-23	23-33	33-49	49-75	Variable
Stairs Up	<16.4	16.4-23	23-33	33-43	43-56	Variable
Stairs Down	<20	20-26	26-36	36-46	46-62	Variable
	Spacing (m <sup>2</sup> /ped)					
Walkways	>5.6	3.7-5.6	2.2-3.7	1.4-2.2	0.75-1.4	<0.75
Stairs	>1.9	1.4-1.9	0.9-1.4	0.7-0.9	0.4-0.7	<0.4
	Walking Speed (m/min)					
Walkways	>78	76-78	73-76	68-72	45-68	<45
Stairs Up	>30	30	30	27-30	21-27	<21
Stairs Down	>37	37	37	30-37	23-30	<23

**Table 20-10—Pedestrian Road Crossing Level of Service (LOS)**

Level of Service	Signalized Intersection*	Unsignalized Intersection*	Pedestrian Noncompliance
A	<10	< 5	Low
B	10-20	5-10	
C	20-30	10-20	Moderate
D	30-40	20-30	
E	40-60	30-45	High
F	≥60	≥045	Very High

\* Average Delay per Pedestrian in Seconds

Source: Ref. 31.

- 5 **Environmental review.** Impacts to the pedestrian network need to be evaluated in environmental review documents prepared according to either NEPA or CEQA, or in traffic impact analysis studies. Impacts are considered significant if a project disrupts existing pedestrian facilities, interferes with planned facilities, conflicts or is inconsistent with adopted pedestrian system plans, guidelines, policies or standards. Examples include projects that add vehicular traffic (including bicycles) to an already poor pedestrian environment, or that generate pedestrian traffic where there are no sidewalks. Non-direct impacts to pedestrians can include the re-timing of signals that shortens the pedestrian crossing phase or generally exacerbates pedestrian mobility.
- a. *Pedestrian significance criteria.* Pedestrians are often overlooked in transportation impact studies conducted for development proposals because there is little policy direction or precedent for determining what is a pedestrian impact. For the few jurisdictions that require analysis of pedestrian issues as part of these studies, pedestrian impacts are considered significant if:
- a project disrupts existing pedestrian facilities. This can include adding new vehicular, pedestrian, or bicycle traffic to an area experiencing pedestrian safety concerns such as an adjacent crosswalk or school.
  - a project interferes with planned pedestrian facilities. In existing and/or planned urbanized areas, main streets, or pedestrian districts, this can include impacts to the quality of the walking environment. Where local policies support such an assessment, this can include an analysis of the relationship of the proposed project (proximity to sidewalk, activity of the frontage, etc.) to adjacent streets from a pedestrian's perspective.
  - a project conflicts or creates inconsistencies with adopted pedestrian system plans, guidelines, policies or standards. The most frequent inconsistency will likely be the

lack of sidewalks. Where yet-to-be-built sidewalks are intended to be part of a larger system of connected pedestrian facilities and/or the ultimate street section includes sidewalks, appropriate mitigation may be that the project fund and/or construct these sidewalks. Similarly, if a proposed trail traverses the project site, an appropriate mitigation may be for the project to fund and/or construct the portion of the trail within (and perhaps immediately adjacent to) the project site. For cities that have adopted pedestrian-supportive design guidelines or standards, the project's consistency with these guidelines or standards should be assessed.

- b. *Pedestrian exposure.* Many communities have concerns about pedestrian exposure; e.g., that adding vehicular or pedestrian traffic to an intersection with a high number of pedestrian collisions may create additional potentially unsafe exposure for pedestrians. At present, there is no basis for identifying impacts related to exposure. In 2006 the Transportation Research Board (TRB) in 2006 has several research projects in process seeking to establish relationships between design features (presence of a median refuge for example) and safety.
- c. *Site plan review.* One of the most valuable exercises transportation professionals can perform is to review site and improvement plans for public and private projects to ensure that pedestrians have been adequately considered. Key components of this analysis are checking that connections between street sidewalks and the entry point of buildings are provided and that pedestrians can safely circulate throughout the site.

## E. Pedestrian Design

The Institute of Transportation Engineers' recommended practice, *Design and Safety of Pedestrian Facilities* (Ref. 32), has a good summary of pedestrian facilities. Chap. 13 of the *HCM* (Ref. 28) covers sidewalk widths and pedestrian levels of service. FHWA's *Course On Bicycle and Pedestrian Transportation* (Ref. 9) provides detailed design guidance for accommodating pedestrians.

### 1 Sidewalks.

- a. *Elements of successful sidewalks.* Sidewalks are recommended on both sides of all urban arterial, collector, and most local roadways because separating pedestrians from motorized traffic is essential for providing safe and functional roadways for all users.
- b. *U.S. Access Board's Draft Guidelines.* The U.S. Access Board released its Draft Guidelines for Accessible Public Rights-of-Way (Ref. 33) in 2002. It will likely be several years, however, before the Department of Justice and other federal agencies finish their rulemaking procedures and adopt these (or other) pedestrian access route guidelines.

While jurisdictions are legally required to comply only with the latest ADA guidelines when building or renovating facilities, they may want to voluntarily follow the specifications in the Draft Guidelines in order to better meet the needs of people with disabilities (as long as the specifications in the Draft Guidelines provide more accessible conditions than the currently adopted ADA guidelines). Engineers in California should also follow the accessibility requirements laid out in Title 24 of the California Building Standards Administrative Code, which are often more stringent than those in ADAAG (Ref. 34). Engineers should consider other factors, such as surrounding land uses (CBD, residential, rural, etc.), pedestrian attractors (e.g., schools and shops), and local policies and codes, in designing facilities that either meet or surpass the ADA's accessibility requirements.

The U.S. Access Board's proposed guidelines for pedestrian access routes include the following specifications for sidewalks and other walking surfaces, crosswalks, curb ramps, and other pedestrian environments (Ref. 33).

- (1) *Minimum Clear Width.* The minimum clear width of a pedestrian access route shall be 1220 mm, exclusive of the width of the curb (Table 20-11).



- (2) *Cross-slope.* The cross slope of the pedestrian access route shall be 1:48 maximum.
- (3) *Grade.* The grade of the pedestrian access route within a sidewalk shall not exceed the grade established for the adjacent roadway, except if the pedestrian access route is less than 1:20, or complies with ADAAG (Sec. 405). ADAAG allows maximum grades along pathways of 1:12 for a distance of 9.14 m before a landing must be installed.
- (4) *Surfaces.* ADAAG Section 302 requires surfaces to be firm, stable, and slip-resistant and prohibits openings that are more than 12.7 mm in one dimension.

**Table 20-11—Minimum Pedestrian Clear Area (excluding sidewalk obstructions)**

Pedestrian Flow Rate (pedestrians/hour)	Pedestrian Level of Service				
	LOS A	LOS B	LOS C	LOS D	LOS E
Less than 600	1.5 m	1.2 m	1.2 m	1.2 m	1.2 m
600 to 1,200	3.1 m	1.2m	1.2 m	1.2 m	1.2 m
1,200 to 2,400	6.1 m	1.8 m	1.5 m	1.2 m	1.2 m
2,400 to 3,600	Not recommended	2.8 m	1.8 m	1.5 m	1.2 m
3,600 to 4,800		3.7 m	2.5 m	1.8 m	1.2 m
4,800 to 6,000		4.6 m	3.1 m	2.1 m	1.2 m
6,000 to 7,200		5.5 m	3.7 m	2.5 m	1.5
7,200 to 8,400		6.1 m	4.3 m	3.1 m	1.8 m
8,400 to 9,600		7.1 m	4.9 m	3.4 m	2.1 m
9,600 to 10,800		8.0 m	5.5 m	3.7 m	2.5 m
10,800 to 12,000		8.9 m	6.1 m	4.3 m	2.5 m

Source: Ref. 35

- (5) *Changes in Level.* ADAAG Section 303 specifies level changes up to 6.35 mm (with-out treatment), level changes between 6.35-12.7 mm (beveled with a slope no greater than 1:2), and level changes greater than 12.7 mm treated as ramps or curb ramps. Changes in level need to be horizontally separated by at least 760 mm.
- (6) *Protruding Objects.* Objects mounted on walls or posts with leading edges above the standard sweep of canes (690 mm) and below the standard head room clearance (2.03 m) would be limited to a 101.6 mm protrusion.

**2 Curb ramps.** Curb ramps are required whenever new or altered pedestrian walkways cross curbs or intersect other walkways. Curb ramps are usually either perpendicular or parallel in shape (Figs. 20-11 and 20-12). Blended transitions (Fig. 20-13) provide a gradual and gentle connection between streets and sidewalks. The U.S. Access Board's Draft Guidelines for Accessible Public Rights of Way have curb ramp requirements for clear width (1.22 m minimum), detectable warnings, surfaces, grade breaks, changes in level, counter slopes, clear space, surface firmness, stability, and slip resistance.

- a. *Perpendicular curb ramps* (Fig. 20-11) must provide level landings at the top no less than 1.2 m by 1.2 m, and cannot have a cross slope greater than 1:48 and side flares with greater than a 1:10 slope. Because sidewalks are permitted to follow the running grade of their adjoining roadways, ramps at midblock crossings are allowed to have cross slopes greater than 1:48 to provide for a smooth transition to the street crossing.

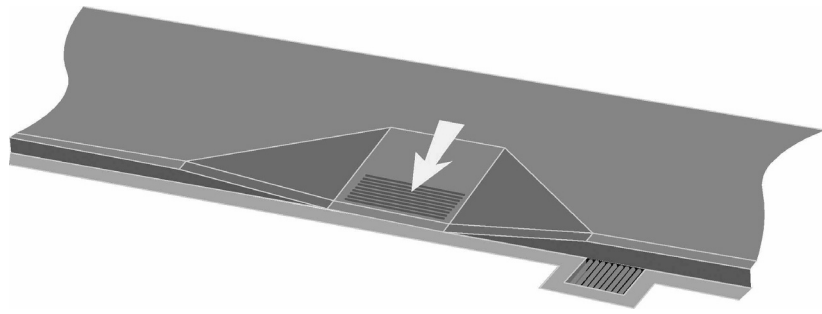

**Fig. 20-11—Perpendicular Curb Ramp**

- b. *Parallel curb ramps* (Fig. 20-12) are useful in locations where there is insufficient space to provide the top landing needed for a perpendicular curb ramp. Instead, the bottom landing usually serves as the direct connection to the street crossing. Criteria for parallel curb ramps address the running slope (1:12 maximum and 1:48 minimum), cross slope (1:48 maximum), level landings at the bottom (at least 1.2 m by 1.2 m), and barriers at drop-offs. The running slope of parallel curb ramps may be as steep as the adjacent roadway.

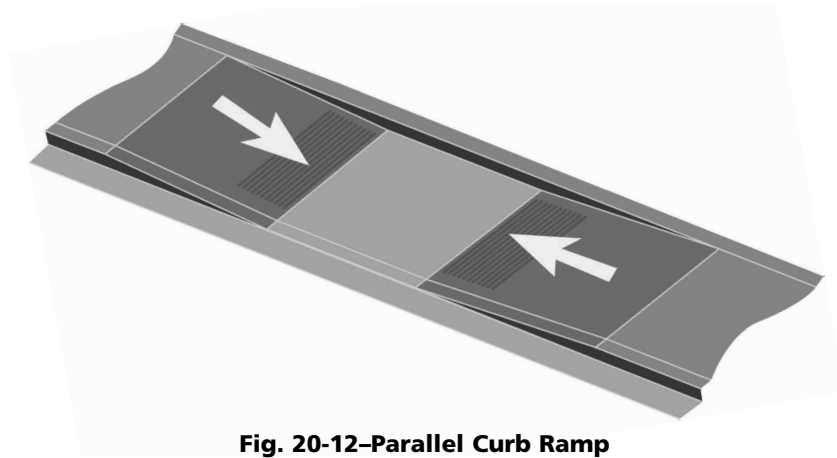

**Fig. 20-12—Parallel Curb Ramp**

- c. *Blended transitions* (Fig. 20-13) cannot have slopes parallel and perpendicular to the curb greater than 1:48. Transitions with slopes greater than 1:48 are treated as curb ramps.

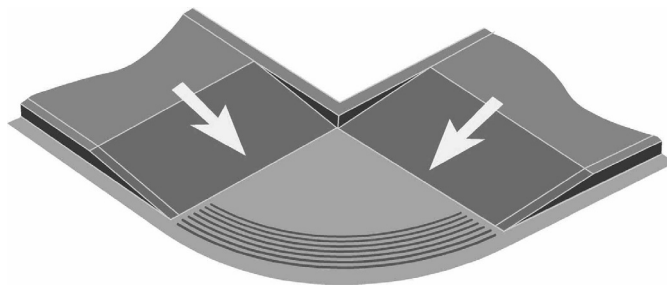

**Fig. 20-13—Blended Transition Ramp**

- d. *Detectable warnings* alert people with vision impairments to nearby transitions from a walkway to a roadway by providing a surface of truncated domes that can be detected by cane or underfoot. These curb ramp warnings provide tactile cues about street proximity that would have otherwise been provided by angular curb faces. Detectable warnings are required to be 0.61 m deep where ramps, landings, or blended transitions connect to crosswalks.

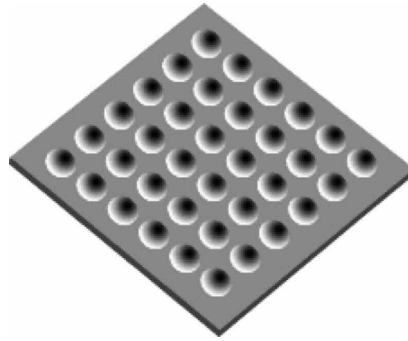

**Fig. 20-14–Detectable Warning Tile**

A detectable tile (Fig. 20-14) is placed at the base of curb ramps with a minimal slope of 1:15 to alert pedestrians with impaired vision to the transition from sidewalk to street. They are installed in alignment with the crosswalk so that the domes provide a tactile cue to guide pedestrians the direction of the crossing. Colors which contrast with the sidewalk and pavement surfaces (yellow, red) provide a strong visual alert, to reinforce the tactile warning.

**3 Intersections.** Intersections must be designed to provide safety, convenience, and accessibility for pedestrians. Well-designed intersections increase pedestrian visibility; encourage predictable pedestrian and driver behaviors; slow vehicular traffic (for increased reaction time and safety); and reduce how far and long pedestrians must travel to cross streets, thereby reducing pedestrians' exposure to potential conflicts.

a. *Designing intersections for pedestrians.* ITE's *Design and Safety of Pedestrian Facilities: A Recommended Practice* (Ref. 32) provides the following guidance for designing intersections:

- pay attention to vertical and horizontal sight distances
- prohibit parking near intersections
- use curb bulbs, curb ramps, and signalization
- limit right-turn-on-red movements in areas with high pedestrian volumes
- keep crosswalks at right angles to turning roadway terminals and slip lanes
- keep right turn speeds below 24 kph and left turns below 32 kph
- locate crossings close to parallel streets
- use stop lines and keep them behind crosswalks
- determine how much storage space at corners is needed for pedestrians

Characteristics of good signalized intersections also include short pedestrian crossings, medians for multi-lane streets, crosswalks on all approaches, signal controllers and poles outside of walking areas, pedestrian signal heads at each crosswalk, short cycle lengths, good lighting (see 3.d. below), and two ADA-compliant curb ramps at each corner.

b. *Pedestrian refuge islands.* (See also Chap. 18.) Refuge area medians work best if they are greater than the width of the crosswalk or 3.6 m, have a surface area of at least 4.6 sq. m., are free of obstructions, have adequate drainage, and provide a flat, street-level surface to provide accessibility to people with disabilities. All refuge areas should be at least 1.2 m wide, and can be 1.5 m wide on streets with speeds between 40–48 kph, 1.8 m (48–56 kph), and 2.4 m (56–72 kph). Pedestrian refuge islands are most beneficial on streets that:

- are greater than 14.4 m wide, have two-way, high traffic volume (over 12,000 ADT), and/or high travel speed (over 56 kph) and large pedestrian volumes
- have insufficient gaps in two-directional traffic to permit safe and convenient pedestrian crossings in one movement
- have many elderly, child, and disabled pedestrians
- have signalized intersections with insufficient green signal intervals for pedestrian crossings, including those at low-volume cross streets where side street green times are less than pedestrian crossing times (Ref. 36)

- c. *Intersection curb bulbs.* Curb extensions (or "bulbs") reduce the crossing width of streets for pedestrians, thereby reducing exposure to collisions (Fig. 20-15). They can also provide opportunities to include amenities (e.g., street trees, bicycle parking, and café seating) without reducing the effective widths of sidewalks. Curb bulbs ideally protrude the full width of adjacent on-street parking stalls (or at least a minimum of 2 m) into the roadway. Curb return radii should be between 3 and 4.5 m where residential streets intersect other residential or arterial streets, 6 m where arterial streets intersect, and 7.5 - 9.0 m where arterial bus or truck routes intersect.
- d. *Lighting.* Lighting requirements for pedestrians differ from those for motor vehicles. For instance, typical "cobra"-style lampposts are designed to illuminate streets, but do not usually illuminate sidewalks and other areas where pedestrians travel frequently. Lighting for pedestrians is often placed on lower standards at more frequent intervals than roadway lighting. Pedestrian-oriented lighting increases real and perceived safety for pedestrians, and can help increase their level of comfort walking after dark. Lighting levels in pedestrian areas should meet those recommended by the Illuminating Engineering Society. (See Chap. 28.)

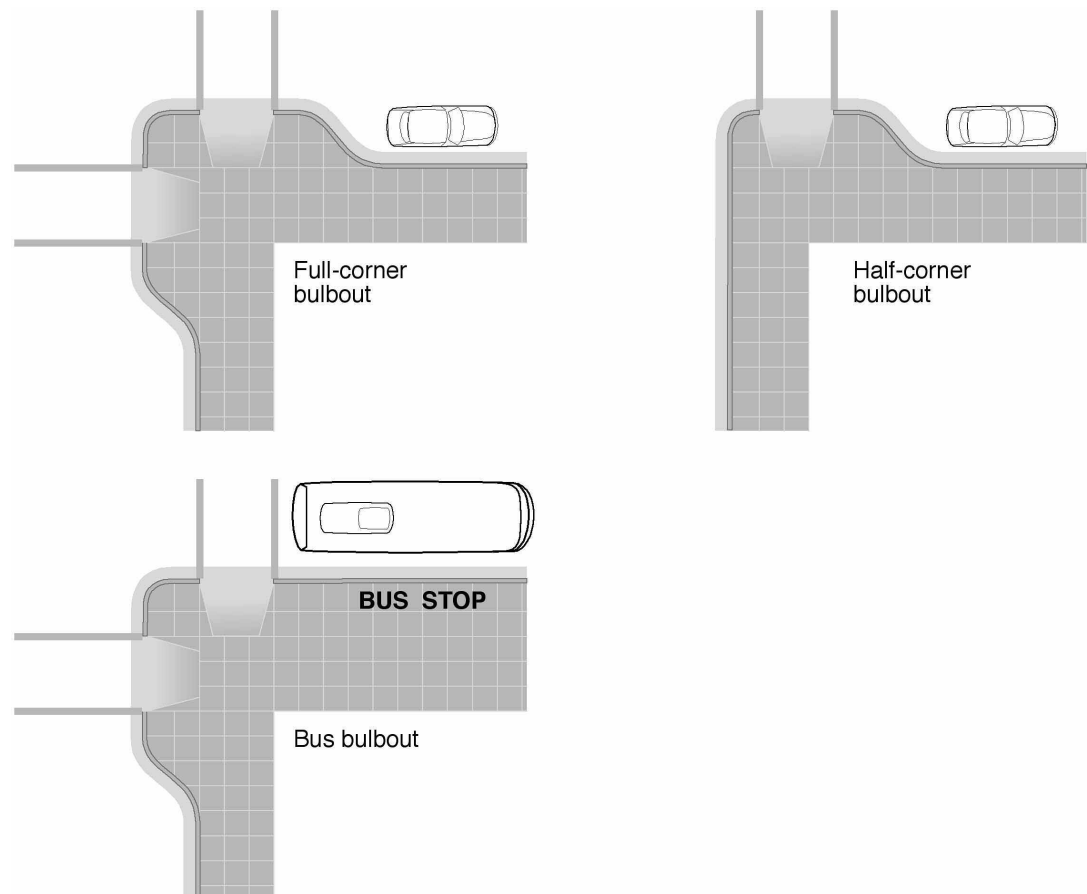

Source: Ref. 15

**Fig. 20-15—Intersection Curb Bulbs**

- 4 **Crosswalks.** Legally, the extension of any sidewalk into an intersection is a crosswalk, whether marked or not. Marked crosswalks (Fig. 20-16) create visible indications of where pedestrians may be expected to cross roadways. They should be located at all open legs of signalized intersections, and may also be used in other locations as warranted (especially places with many young, old, or disabled pedestrians). Design elements such as curb bulbs, signage, and illumination can help make pedestrian crossings more visible and pedestrian crossing behavior more predictable.

Crosswalks should be placed at a 90° angle to the roadway, and be located where visibility is not obscured by parked cars, overgrown foliage, signs, etc.. They are delineated by two white parallel lines that are 0.2–0.6 m wide, spaced at a minimum of 1.8 m (3 m is the standard width), or the width of the approaching sidewalk, whichever is greater. (In California, yellow paint must be used near schools.) Special markings, e.g., diagonal crosshatched and longitudinal "zebra"-striped lines, and textured crossings, e.g., non-slip bricks, embossed concrete, and colored pavers, may be used to further increase pedestrian and motorist visibility. Warrants for high-visibility crosswalk treatments include one or more of the following: high vehicle speed, high pedestrian volumes, school crossings, unexpected crossing locations (including midblock), and engineering judgment (Ref. 32, p. 54).

The Institute of Transportation Engineers suggests that certain conditions may not warrant the installation of marked crosswalks, e.g., when the hourly peak pedestrian volume is <25 pedestrians per peak 4 hours, or when traffic volume is <2,000 ADT. While studies from the 1970s reported that more pedestrian collisions at unsignalized locations occurred in marked crosswalks than in unmarked crosswalks, a recent study found that marked crosswalks were as safe as locations without marked crosswalks in all of the conditions studied (Ref. 32).

For signal-enhanced crosswalks, see the next section.

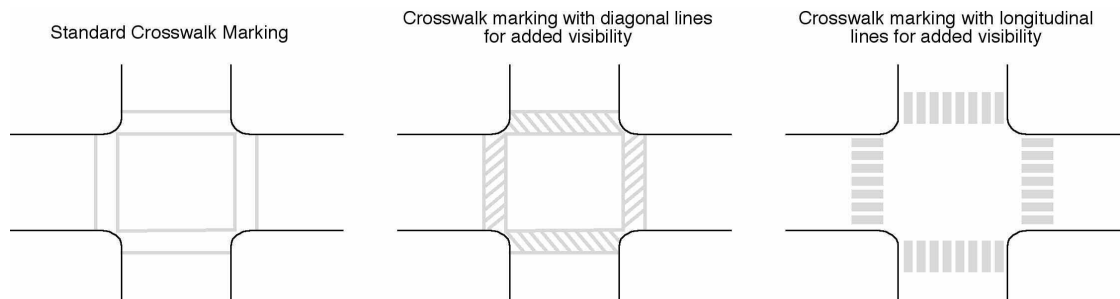

**Fig. 20-16—Typical Crosswalk Markings**

- 5 **Traffic signals** (Ref. 23, Chap. 4E). Many new designs and technologies for improved pedestrian crossing safety have been included in the 2003 edition of the *MUTCD* (Fig. 20-17). Pedestrian safety at intersections with high numbers of turning vehicles can be improved by installing Animated Eye LED (Light Emitting Diode) signals, which add an animation of shifting eyes to a pedestrian signal. The animated eyes remind pedestrians to watch for turning vehicles. Adjusting signal phasing by adding an Early Release (increasing pedestrian lead-time) permits pedestrians to establish themselves in the crosswalk prior to the vehicle phase. Pedestrian-only ("scramble") programs add a pedestrian-only interval to permit pedestrians to cross all legs of the intersection simultaneously, including diagonally across the middle of the intersection, while all vehicle traffic is stopped.

The forecasting tools and electronic equipment available to traffic engineers today allow a high degree of intersection signal programming optimization. When the optimization goal is to move traffic efficiently, it may have negative effects on pedestrians. Split phases often preclude parallel pedestrian crossings, and left-turning traffic can give misleading cues to vision-impaired pedestrians. Protected-permissive phasing (Chap. 15 and 16) creates a situation where parallel pedestrians can come into conflict with left-turners. Lagging pedestrian intervals, sometimes used to allow right-turning vehicles a head start before the conflicting pedestrian movements are permitted to move, create confusion for pedestrians who watch both the vehicle and pedestrian indications.

Emerging design options for enhanced crosswalks include:

- *Half signals* provide a traditional traffic signal on the major street, but the signal is only activated by a pedestrian call; traffic on the crossing street is controlled by stop signs.

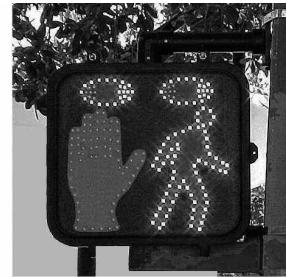

Audible Signal

Accessible  
Push-Button Signal

Automated Eyes

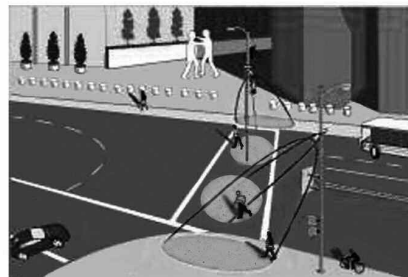

Passive Pedestrian Detection



Countdown Signal

**Fig. 20-17—Traffic Signal Innovations**

- *Pelicans* give motorists a steady red when pedestrians have a steady green, but as the pedestrian timing progresses to the clearance interval, motorists see a flashing yellow, allowing them to cross the intersection if the pedestrians have cleared.
  - *Puffin* (Pedestrian User Friendly Intelligent) crossings expand on the Pelican by using active pedestrian detection technologies to better control the length of the pedestrian crossing phase.
  - *Toucan* (Two groups Can cross) crossings are designed for both bicyclists and pedestrians, and operate like Pelican crossings with the exception of a blank signal during the clearance phase.
  - *Hawks* (High intensity Activated Walk) are a variation of the pedestrian-activated signal for school and emergency crossing locations. Motorists face a standard traffic signal head with a yellow and two red lenses. When a pedestrian makes a call, the signal flashes yellow, changing to a solid yellow to warn of the impending stop interval. A solid red marks the beginning of the pedestrian crossing interval, replaced by a flashing red during the pedestrian clearance interval.
- 6 Pedestrian Overpasses and Tunnels.** Pedestrian facilities at-grade and as directly as possible are always preferred. However, where grade separation is indicated, paths that are attractive, convenient, and direct can become well-used and highly valued parts of a city's pedestrian infrastructure. Facilities that are perceived to be inconvenient, confusing, unsafe, and uncomfortable serves to discourage pedestrian mobility.
- These are expensive methods of pedestrian control, but can eliminate all or most conflicts. They provide pedestrian routes across freeways and at grade railroad and rapid transit tracks where the nearest alternate crossing location is unacceptably far away. They may also be warranted for critical locations, such as schools, factory gates, sports arenas, and major downtown intersections (especially in conjunction with transit stations). Barriers should be included to block undesirable street level crossing.
  - Overpasses are less expensive and present fewer policing and cleaning problems than tunnels. However, vertical rise and fall to be negotiated by pedestrians is usually greater for

an overpass, and it may be aesthetically inferior. In downtown areas, the safety and attractiveness of tunnels may be enhanced by providing space for lighted store display windows entrances into adjacent stores, or for complete underground shops.

- Pedestrian paths on these facilities require a minimum width of 1.22 m, although 1.83 m is preferred. On existing bridges without enough space for a pedestrian walkway, a cantilevered path off the side of the bridge or a parallel bridge for pedestrians are options. Ramps with slopes no greater than 1:12 (8.3%) are preferable to flights of stairs to accommodate wheelchairs, strollers, and bicycles, and to comply with the ADA. Ramps for an overpass that is 6 m above a roadway will be about 80 m long, including a landing for each 750 mm rise in elevation. Where such ramps cannot be fitted into available space, elevators may be required by the ADA. At high pedestrian volume locations escalators may be justified. Adequate levels of illumination and acoustic dampening need to be considered if pedestrian access is provided through a tunnel.
- 7 **Transit facilities.** Walking is a necessary component of transit mobility. Therefore, providing pedestrian facilities at and near transit stops supports both transit development and pedestrian mobility. Transit stops should mesh with existing pedestrian networks. Pedestrian access to and from transit should be direct, safe, and separated from vehicle facilities, such as parking and carpool lots. Pedestrian crossing facilities within 400 m of a transit stop should receive enhanced crossing measures and, if signalized, may have shorter cycle times to allow for greater pedestrian mobility. Bus and corner bulb-outs can help both transit and pedestrian accessibility (Fig. 22-15).
  - 8 **Trails.** Where pedestrian facilities are separate from roadways, as in the case of multi-use trails and paths, they often cross roadways away from existing intersections. These crossings require advanced warning to alert drivers that they are approaching a pedestrian crossing. For traffic control at the crossing, the strategies and solutions are generally the same as for other pedestrian crossings at roadway intersections. See also Chap. 21, Sec. G.5.
  - 9 **Special cases.** Good intersection design can eliminate many of the conditions which lead to difficult pedestrian crossings. Still, there are many cases where a difficult crossing cannot be avoided and extra attention is needed to ensure a safe crossing design.
    - a. *Highway interchanges.* Loop ramps and free right-turns for traffic entering and exiting high-speed roadways combine a shallow crossing angle with high traffic speeds, creating a challenging pedestrian crossing environment. As motorists transition between low-speed surface streets and high-speed freeways, they need to be aware of any pedestrians crossing at the end of the off-ramp and the entrance of the on-ramp. When refuge islands or narrowed crossing distances (less than two lanes) are provided pedestrians will experience lower exposure. Free-flowing traffic without Stop or Yield control is not appropriate for areas with expected pedestrian use. Instead, on-and off-ramps with tighter turning radii and right-angle intersections improve driver visibility and reduce vehicle speed, both of which increase pedestrian safety. Many existing highway access points can easily be retrofitted to increase allocated space for pedestrians (and bicycles). Of course, new highway projects should include such safe and convenient features.
    - b. *Multiple turn lanes.* Multiple turn lanes result in increased crossing width and can lead drivers to focus on safely making the turn with the parallel traffic rather than on a pedestrian that might be crossing the intersection.
    - c. *Free right-turns.* Right-turn slip lanes with exit angles between 50° and 60° can also help slow traffic down. Fig. 20-18 shows the standard and preferred standard for slip lanes.
    - d. *Roundabouts.* Roundabouts are generally safer than signalized intersections, with fewer collisions and less severe injuries for drivers and pedestrians. They present a challenge to vision-impaired pedestrians, who may have difficulties discerning the direction of travel of vehicles in the roundabout.

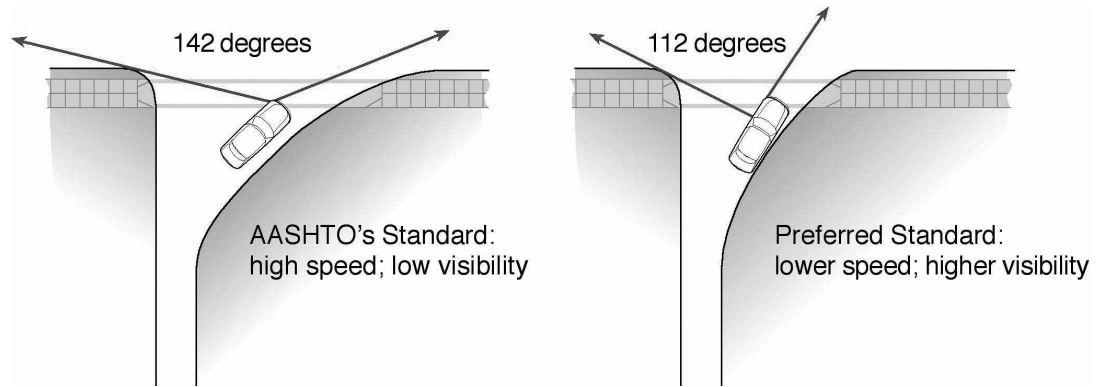

**Figure 20-18—Free Right Turn Intersection Angles**

- e. *Skewed intersections.* The more an intersection angle deviates from  $90^\circ$ , the greater the crossing distance for pedestrians and vehicles. This leads to an increase in crossing time, resulting in long pedestrian intervals (if the intersection is signalized), and greater pedestrian exposure. If the longer pedestrian clearance intervals adversely affects vehicular LOS at the intersection, a split pedestrian crossing with a refuge for pedestrians in the center of the intersection will allow for shorter pedestrian clearance intervals.

**10 Escalators and Moving Belts** (Ref. 37). These devices are used as aids to save pedestrians effort where large numbers of persons must walk long distances, or overcome differences in elevation, or both. They cannot operate at sufficiently high speeds to save much time; when crowded to the point at which walking on them becomes impossible, they are slower than walking on fixed stair, ramps, or walkways. Typical speeds are 0.5–0.6 m/s. Capacity is 45–60 persons/minute/"lane" of 540–600 mm width. A pair of balustrades containing moving handrails occupies 700–840 mm. A complete 2-lane escalator or belt therefore requires 1750–2000 mm in width, and can transport up to 120 persons/minute.

Escalators are frequently used to connect different levels in buildings (up to about five floors), stadiums, rapid transit stations, bus terminals and other locations where the demand for vertical transportation capacity is large. The standard angle of rise is  $30^\circ$ . Curved escalators have recently made their appearance, for example, in a department store in San Francisco.

Horizontal belts, generally moving at 0.5–0.6 m/s, are used to assist in areas such as airports and large parking facilities, where long walks may be required. They can also operate at angles up to  $15^\circ$  and can therefore also be used to overcome differences in elevation, e.g. in downtown Tacoma, WA and at the San Diego Zoo. Strollers and shopping carts can be taken on belts. However, at steeper grades horizontal steps of escalators are safer and more comfortable than the sloping surface of belts. (Escalators for shopping carts have recently appeared in new megastores.)

## F. Child Safety and School Programs

### 1 Child pedestrians.

- a. *Walking exposure.* Thirty years ago, more than 50% of children walked or biked to school (Ref. 38). Early in the 21st century, only 14% of school trips were by foot or bike (which account for less than 1% of all student-miles traveled), and over 59% are by car and 27% by school or transit bus (Ref. 39). In national studies, 40% of parents cited traffic as the major barrier to allowing their children to walk or bike to school, and nearly 60% of children were found to encounter at least one "serious hazard" along their school routes (Ref. 38). Of the 16% of parents who reported "no barriers," 64% reported children walking to or from school at least once a week during the previous month (Ref. 40).



- b. *Collisions with children.* In 2004, children aged 15 and under accounted for 8.5% of all pedestrian deaths and for 29.4% of all pedestrian injuries (Ref. 15). More than half of all toddler pedestrian injuries occur when a vehicle is backing up, and nearly 10% of all childhood pedestrian-related injuries occur in driveways. On a per student-mile basis, school-age bicyclists suffer the highest injury and fatality rates, followed by school-age pedestrians. Children who bike or walk to school make up 11% of children injured and 22% of children killed from motor vehicle crashes during normal school travel hours (Ref. 41).

Children are at increased risk of pedestrian injuries because of their limited understanding – often overestimated by adults – of traffic signals and behavior, and by their smaller bodies which are less visible to drivers (Refs. 10 and 11). School zones are also challenging places for child pedestrians because school drop-off and pick-up traffic can be heavily congested and frantic.

## 2 Countermeasures, Enforcement, and Promotion.

### a. Countermeasures.

- (1) *Signals.* The *MUTCD* warrant for signals at school crossings (Ref. 23b) is based on the frequency and adequacy of gaps in the vehicular traffic stream related to the number of school children wishing to cross. (Ref. 23b describes a method for such studies.) A signal may be warranted if, "the number of adequate gaps in the traffic stream during the period when the children are using the crossing is less than the number of minutes in the same period."
- (2) *Flashing Beacons.* The *MUTCD* provides for optional flashing yellow beacons to supplement special speed limit signs when such limit applies only during school hours. The speed limit sign is supplemented by a plate reading "When Flashing." A timing mechanism turns off the flashing beacon when it is not required.
- (3) *Signs.* The *MUTCD* lists all signs accepted for use around schools. In-street signs are permitted at unsignalized school crosswalks to provide an extra measure of warning to drivers. The sign (Fig. 20–19) reminds drivers of the state law to either yield or stop for pedestrians in the school crossing.



**Figure 20-19–In-Street Warning Sign**

### b. Enforcement.

- (1) *Speed Control.* Enforcing safe speeds around schools, especially during drop-off and pick-up times, is crucial for maintaining child pedestrian safety. Despite posted low speed limits (17 states have mandated speed limits of 25 or 32 km/h 15 or 20 mph – near schools), two-thirds of U.S. drivers exceeded posted school zone speed limits for the 30 minutes before school starts and after it ends (Ref. 42).

- (2) *Police officers, adult guards, and school patrols.* Where traffic is substantial, especially in rural areas, crossing guards may be required to halt traffic and permit children to cross. With good training, school patrols can also be used as crossing guards at signalized intersections.
- c. *Promotion.*
- (1) *Safe Routes to School.* In communities worldwide, Safe Routes to School (SR2S) programs aim to enable children to walk or bicycle to school. SR2S programs can benefit communities through increased traffic safety, child health and fitness, community cohesion, and decreases of air pollution and other environmental hazards (Ref. 43). Most SR2S programs assess the safety of school travel routes, make infrastructure changes (such as new crosswalks or traffic calming), educate students and drivers about safe travel behavior, increase traffic enforcement or the use of school crossing guards, and use a variety of methods to promote walking and biking to school (Ref. 44). The movement is rapidly growing, as the U.S. government and some states have passed legislation dedicating funding for SR2S efforts. In 2003, 3,000 U.S. schools in all 50 states, and over 3,000,000 walkers in 29 countries participated in International Walk to School Day (Ref. 43). Substantial benefits were found in pedestrian safety, physical activity, and obesity prevention, along with smaller benefits in air quality.
- (2) *Walking school buses* (Ref. 45). In this program, small groups of children walk to school together under adult supervision, thus helping to allay some concerns about children being unsupervised, hurt in traffic, or abducted. In Chicago, more than 175 schools participate in a walking school bus program developed by the police department.

## REFERENCES

1. U.S. Department of Transportation (DOT), National Highway Traffic Safety Administration (NHTSA). *Resource Guide on Laws Related to Bicycle and Pedestrian Safety*, Jan. 2002. Available: [http://www.nhtsa.dot.gov/people/injury/pedbimot/bike/\\_resourceguide/index.html](http://www.nhtsa.dot.gov/people/injury/pedbimot/bike/_resourceguide/index.html).
2. Litman, Todd. "Economic Value of Walkability." *Transportation Research Record* 1828, 2003.
3. U.S. DOT, NHTSA. *2002 National Survey of Pedestrian & Bicyclist Attitudes and Behaviors*. Available: <http://www.walkinginfo.org/survey2002.htm>.
4. "Predicting Demand." Available: <http://www.walkinginfo.org/pp/predicting/index.htm>.
5. U.S. DOT, Bureau of Transportation Statistics (BTS), *Principal Means of Transportation to Work*. Available: [http://www.bts.gov/publications/national\\_transportation\\_statistics/2002/html/table\\_01\\_35.html](http://www.bts.gov/publications/national_transportation_statistics/2002/html/table_01_35.html). And U.S. DOT, BTS, *National Transportation Statistics 2003*.
6. "TEA-21 Reauthorization - Transportation Enhancements." Available: <http://www.railtrails.org/whatwedo/policy/positionpaper.asp>.
7. U.S. Federal Highway Administration (FHWA), *National Bicycling and Walking Study: Ten Year Status Report, 2004*.
8. U.S. DOT, BTS, National Transportation Statistics 2001, Table HF-10.
9. U.S. FHWA, "Pedestrians with Disabilities," *Course on Bicycle and Pedestrian Transportation*. Available: [http://safety.fhwa.dot.gov/ped\\_bike/univcourse/swless17.htm](http://safety.fhwa.dot.gov/ped_bike/univcourse/swless17.htm).
10. U.S. National Center for Injury Prevention and Control, Centers for Disease Control, *Injury Factbook*, 2001-02, pp. 78-81. Available: [http://www.cdc.gov/ncipc/fact\\_book/19\\_Pedestrian.htm](http://www.cdc.gov/ncipc/fact_book/19_Pedestrian.htm) [sic].
11. National SAFE KIDS Campaign. *How Far Have We Come?* 2004. Available: [www.transact.org/library/reports\\_html/ms2004/pdf/Final\\_Mean\\_Streets\\_2004\\_4.pdf](http://www.transact.org/library/reports_html/ms2004/pdf/Final_Mean_Streets_2004_4.pdf).
12. U.S. DOT. 1995 Nationwide Personal Transportation Survey, reported in *Injury Factbook* (Ref. 10).
13. Ewing, R.. *Pedestrian- and Transit-Friendly Design*. Washington, DC: Smart Growth Network, 1999.

14. U.S. FHWA, "Planning and Designing Pedestrian Facilities," *Course on Bicycle and Pedestrian Transportation*. Available: [http://safety.fhwa.dot.gov/ped\\_bike/univcourse/swless17.htm](http://safety.fhwa.dot.gov/ped_bike/univcourse/swless17.htm).
15. U.S. NHTSA, *Traffic Safety Facts 2004—Pedestrians*. DOT HS 809 913, 2005. Available: <http://www-nrd.nhtsa.dot.gov/pdf/nrd30/NCSA/TSF2004/809913.pdf>
16. U.S. DOT. BTS. *Highlights of the 2001 National Household Travel Survey*. Available: [http://www.bts.gov/publications/highlights\\_of\\_the\\_2001\\_national\\_household\\_travel\\_survey/](http://www.bts.gov/publications/highlights_of_the_2001_national_household_travel_survey/).
17. National Center for Statistics & Analysis, NHTSA, *Lifesavers 2004: Analysis of Pedestrian Fatalities*. Mar. 29, 2004. Available: <http://www-nrd.nhtsa.dot.gov/pdf/nrd-30/NCSA/PPT/lifesavers2004.pdf>.
18. National Center for Statistics & Analysis, NHTSA, *2003 Annual Assessment of Motor Vehicle Crashes*, Aug. 2004, p. 123. Available: [www-nrd.nhtsa.dot.gov/pdf/nrd-30/NCSA/PPT/2003AARrelease.pdf](http://www-nrd.nhtsa.dot.gov/pdf/nrd-30/NCSA/PPT/2003AARrelease.pdf).
19. "Injuries to Pedestrians and Bicyclists: An Analysis Based on Hospital Emergency Department Data." FHWA-RD-99-078. Available: [www.tfhrcc.gov/safety/pedbike/research/99078/99-078.htm](http://www.tfhrcc.gov/safety/pedbike/research/99078/99-078.htm). Washington, DC: 1999.
20. NHTSA, *Literature Review on Vehicle Travel Speeds and Pedestrian Injuries, Final Report*. DOT HS 809 021, Oct. 1999. Available: <http://www.nhtsa.dot.gov/people/injury/research/pub/HS809012.html>. Data for chart taken from Florida study of pedestrians 1993-1996 as referenced in above material.
21. FHWA. *Safer Journey: Interactive Pedestrian Safety Awareness CD*, FHWA-SA-03-014. Available: <http://safety.fhwa.dot.gov/saferjourney/>.
22. Fehr & Peers Associates, Inc.
23. U.S. FHWA. *Manual on Uniform Traffic Control Devices for Streets and Highways*
  - a. Washington, DC 1961
  - b. 2003, Rev 1. Washington, DC: 2004. <http://mutcd.fhwa.dot.gov/pdfs/2003r1/pdf-index.htm>.
24. LaPlante, J. and T. Kaeser, "The Continuing Evolution of Pedestrian Walking Speed Assumptions." *ITE Journal*. Sept. 2004, pp.32-40.
25. U.S. BTS, *Bicycle and Pedestrian Data: Sources, Needs, and Gaps*. BTS 00-02, pp. 3, 53-54.
26. Available at: <http://www.fhwa.dot.gov/tfhrcc/safety/pubs/vol1/title.htm>, and [www.bayareatrafficsignals.org/downloads/ped&bike/Handbook\\_Summary.pdf](http://www.bayareatrafficsignals.org/downloads/ped&bike/Handbook_Summary.pdf).
27. Cambridge Systematics, Inc., Bicycle Federation of America, and M. Replogle. *Guidebook on Methods to Estimate Non-Motorized Travel*. Washington, DC: FHWA. June 1998.
28. Transportation Research Board, *Highway Capacity Manual*, National Research Council. Washington, DC: 2000.
29. Available: [http://www.walkinginfo.org/task\\_orders/to\\_8/to8/chap13/sect3.htm#tab4](http://www.walkinginfo.org/task_orders/to_8/to8/chap13/sect3.htm#tab4).
30. Available: <http://www.bikelib.org/roads/blos/losform.htm>.
31. Milazzo, J. et al., "Quality of Service for Interrupted Pedestrian Facilities in the 2000 Highway Capacity Manual." *Transportation Research Record* 1678. 1999.
32. Institute of Transportation Engineers. *Design and Safety of Pedestrian Facilities: A Recommended Practice*. Washington, DC: March 1998.
33. U.S. Access Board. *Draft Guidelines for Accessible Public Rights-of-Way*. June 17, 2002. Available: <http://www.access-board.gov/rowdraft.htm>.
34. California Code of Regulations, Title 24. *California Building Standards Code, 2001 Triennial Edition*. Available at: [http://www.bsc.ca.gov/title\\_24.html](http://www.bsc.ca.gov/title_24.html).

35. Transportation Research Board. *Special Report 209: Highway Capacity Manual*. 1994; Fehr and Peers Associates, 1999.
36. ITS Technology Transfer Program. *Planning and Design of Bicycle and Pedestrian Facilities*, Section 4.2.
37. Tough, J.M. and C,A, OFlaherty. *Passenger Conveyors*. London: Ian Allen, 1971. 176 p.
38. Appleyard, B. *Safe Routes to School*. National Center for Bicycling & Walking. Available: [http://www.bikewalk.org/safe\\_routes\\_to\\_school/SR2S\\_introduction.htm](http://www.bikewalk.org/safe_routes_to_school/SR2S_introduction.htm).
39. California Dept. of Health Services, and the Local Government Commission. *Transportation Tools to Improve Children's Health and Mobility: Look What California Is Doing*. Co-sponsored by the California Office of Traffic Safety Safe Routes to School Initiative, February 19, 2003. Available: [www.saferoutestoschools.org/pdfs/SR2S%20Transportation%20Tools.pdf](http://www.saferoutestoschools.org/pdfs/SR2S%20Transportation%20Tools.pdf).
40. Centers for Disease Control. "Barriers to Children Walking and Biking to School." *MMWR Weekly*. Aug. 2002, pp. 701-704. Available: <http://www.cdc.gov/mmwr/preview/mmwrhtml/mm5132a1.htm>.
41. "The Relative Risks of School Travel: A National Perspective and Guidance for Local Community Risk Assessment." *TR News* 224, Jan.-Feb. 2003, pp. 39-42.
42. "National Survey Reveals Nearly Two-Thirds of Drivers Speed in School Zones, Suggesting Neglect of Child Pedestrians Community Wide." Available: [http://usa.safekids.org/tier3\\_cd.cfm?folder\\_id=300&content\\_item\\_id=474](http://usa.safekids.org/tier3_cd.cfm?folder_id=300&content_item_id=474).
43. Pedestrian and Bicycle Information Center, University of North Carolina Highway Safety Research Center for the Partnership for a Walkable America. *2003 Walk to School Day Report*. Available: <http://www.walktoschool-usa.org/media/index.cfm>.
44. Pedestrian and Bicycle Information Center. Available: <http://www.walktoschool-usa.org/srts.cfm>.
45. Pedestrian and Bicycle Information Center, "Walk to School Initiatives Take Steps Toward a Better Way." Available: <http://www.walktoschool-usa.org/downloads/WTSDbooklet.cfm>.



## A. Introduction

- 1 **Historical context.** Many inventions and innovations developed in the second half of the 19th century led to an easy-to-ride mass-produced bicycle that in turn created the bike craze of the 1890s. These inventions, many of which also contributed to the development of the automobile, took place on both sides of the Atlantic. By 1885, the improved "safety bicycle" had everything modern bicycles have: chains and sprockets, rubber rims, ball bearings, and roughly equal-sized wheels with tangential spokes. Soon to be invented were rack and pinion steering, front and rear suspensions, and in 1888, pneumatic tires were patented by a Scottish physician.

Along with the new mode came political and social activism. The League of American Wheelmen (LAW, now League of American Bicyclists) was founded in 1880 to lobby for the right to use the road along with the existing users: horses, wagons, and pedestrians. Only later would the roads also be used by cars. In the 1890s, LAW lobbied for paved roads under the name "Good Roads Movement." By then, bicycling was exceptionally popular in Detroit: historians attribute the automobile's explosion of growth in Detroit to the network of superior roads built for bicyclists. The federal government got involved in 1905 with the creation of the Office of Public Roads, the forerunner of the FHWA.

The bicycle also had a significant social impact on the status of women. In 1885, when the safety bicycle made bicycling more feasible, women needed something to wear while riding, and bloomers were revived. The bicycle craze killed the bustle and the corset, instituted "common-sense dressing" for women, and increased their mobility considerably. Susan B. Anthony stated: "Bicycling .... has done more to emancipate women than anything else in the world. I stand and rejoice every time I see a woman ride by on a wheel. It gives woman a feeling of freedom and self-reliance." (Ref. 1)

- 2 **Benefits of biking.** Bicycles have several specific benefits within the modern transportation system compared to other modes of passenger travel. Bikes use less roadway space than cars: at capacity 2,400 bikes per hour can be accommodated in a 1.2-m bike lane vs. 2,200 cars per hour in a 3.6-m highway lane. Bike parking takes less space: up to fifteen bikes can park in the space occupied by one automobile, and bikes can usually be stored indoors at home. Bicycling is faster to transit stops than walking, increasing the catchment area of the bus route or subway. Biking is cheaper than public transit or driving, and provides multiple health benefits. It uses only human energy (less than half of the amount required for walking – Ref. 2). Bicycle travel is cheaper by factors of 5 to 60 than all other modes except walking and, of course, produces no air pollutants.

It is good public policy to allow for transportation mode choices. From this point of view there are many reasons to provide for, if not promote, bicycling: (Many of them apply equally to walking.) They are discussed here using the acronym **CHOICES** -- **C**ongestion--**H**ealth--**O**thers--**I**mpacts--**C**ost--**E**fficiency--**S**afety.

- **Congestion:** Many urban areas have realized that they cannot build their way out of congestion. Although increased biking may not be able to reduce congestion noticeably, it is good public policy to expand mode options so that some commuters have an alternative to sitting in traffic. Also, bicycle provides access to schools from within neighborhoods, removing vehicles from collectors and arterials. There is noticeable congestion relief at intersections near schools that implement a walk/bike-to-school program.
- **Health and Fitness:** Public health officials now encourage more bicycling and walking because active lifestyles can lower health care costs. Cycling is available to all ages and fitness levels. Employees who are active are less stressed, use fewer sick days and make fewer health care claims. School children who exercise regularly are healthier and learn more in school.
- **Others:** Nondrivers should be recognized and accommodated. Bicycling is an important mode that can fill the needs of some who, for a variety of reasons, do not drive a car. Many households do not own cars (see Chap. 2, Table 2-4). Many adults do not have a drivers' licenses, especially the elderly (see Chap. 3, Table 3-2). Children do not drive, but can in many circumstances transport themselves via bicycle to school, visit friends, and other after-school and weekend activities.
- **Impacts on the Environment:** Chaps. 29 – 32 describe the adverse environmental impacts related to motor vehicle transportation. Obviously, such impacts do not result from cycling.
- **Cost:** Bicycling is cheaper for the individual: it costs 26 cents per km to operate an automobile (Ref. 3) compared to 4 cents per km to operate a bicycle. Increased bicycling also produces financial benefits to society (Ref. 4).
- **Efficiency:** Cycling is the most energy-efficient form of personal transportation, providing door-to-door access while eliminating the need to find parking. It can also be just as time-efficient as other modes in some circumstances. Cycling is competitive in travel time with local buses, each averaging about 16-20 km/hr. Cycling can compete with cars in travel time for short (less than 3 km) trips, particularly in congested corridors or where parking is difficult to find or located at a distance.
- **Safety:** Chap. 9 details types of safety problems in motor vehicle traffic. There is evidence that the more bicycling and walking, the safer bicyclists and walkers are (Ref. 5). A discussion of bicycle crashes is contained in Sec. C.

## B. Bicycle Characteristics and Bicycle Trips

As discussed in Chap. 3, the fact that humans are at the controls affects many of the operational characteristics of automobiles. This is even truer with bicycling. In addition, unlike motorized modes, children are often the operators of bicycles. In some cases, the elderly continue to bike long after they have given up their drivers' licenses. This vast range of abilities affects everything from the physical height and width of the "vehicle" to the power and therefore travel speed and acceleration rates, as well as the perception and reaction times. Since no license is required, there is a vast range in knowledge of the rules of the road.

For the purposes of this discussion, we will assume the typical "bicycle-vehicle" consists of an average adult with a driver's license, and therefore knowledgeable about the basic rules of the road in his/her state.

- 1 **Physical Dimensions.** The dimensions of a typical adult rider are depicted in Figure 21-1. The lateral space occupied by a single rider is approximately 1 meter, including the essential maneuvering and lateral movement that inevitably occurs. To avoid fixed objects (curbs, shrubs, potholes, signs, etc.) and other users, such as pedestrians and wheelchairs, a bicyclist needs an additional 0.25 m of clearance on each side, bringing the basic width of a one-way corridor to 1.5 m (Ref. 6). As discussed in Sec. G, a two-way facility optimally provides 3 m of width so that two bicyclists can comfortably pass or overtake each other.

2 **Performance and Operating Characteristics.** *Bicycle Transportation* (Ref. 7) contains a detailed discussion of the physics of bicycling. For the purposes of the traffic engineer, the important physical constraints are: turning radii, acceleration, deceleration, braking distance, and stopping sight distance.

For roadway and trail geometrics, the Caltrans *Highway Design Manual (HDM)* (Ref. 8) contains design standards on horizontal and vertical curves for various design speeds as well as information on stopping distances. Factors such as design speed, acceleration, and deceleration affect certain operational parameters e.g., minimum green time and signal clearance time as discussed in Section F.

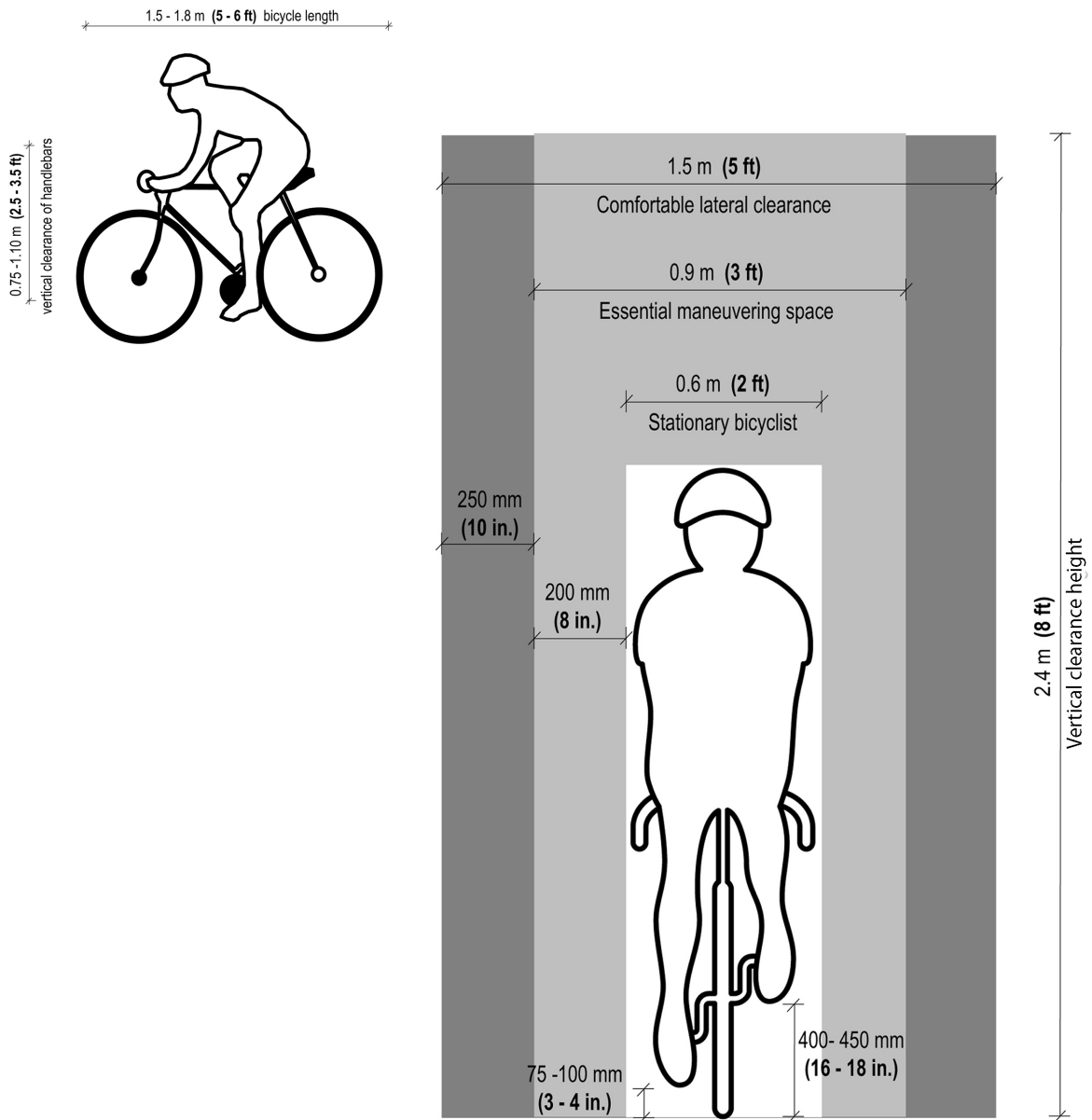

**Fig. 21-1—Bicycle Operating Space**



- 3 Bicycle Trip Lengths and Purposes.** Bike trip lengths are constrained by both muscle power and roadway grade. They are on average about 5 km; 20% are more than 25 km (Ref. 9). Since more than 50 % of all car trips are under 8 km (Ref. 10), bicycling is quite a feasible mode for a significant proportion of trips.

Of all bicycle trips made by adults and children, the breakdowns of trip purposes for a California metropolitan area and nationwide are depicted in Table 21-1.

**Table 21-1—Trip Purposes for Bicycle Trips**

	BATS 2000	NHTS 2001
Work trips	22%	8%
School trips	12%	9%
Shopping trips	26%	Included in personal business
Family / personal business trips	40%	22%
Social or recreation trips.		60%

Sources: Refs. 9 and 10.

## C. Accidents / Crashes / Collisions

- 1 Statistics and Information Sources.** Bicycle crash statistics are available from federal, state and local sources, as indicated in Table 21-2. The most complete data are maintained in local police department records which include non-injury collisions. Each local agency has its own computer software and procedures to tally data and send reports to the traffic engineering or public works department. For statewide data sources, see Chap. 3, Part C.3.

According to these sources, bike fatalities resulting from collisions with motor vehicles have been steadily declining over the past decade, as shown in Table 21-2. Bicycle injuries from motor vehicle crashes also appear to have declined when data from NHTSA are examined. However, data from hospital emergency rooms, which do not differentiate between bike crashes with cars and all other bike crashes, do not show a consistent pattern of declining injuries. This illustrates the disparity between crashes reported to the police and the actual number of bike crashes. Based on the data in Table 21-3, estimates of the number of unreported bicycle crashes are as high as ten for every one reported crash.

In order to better understand more about the unreported crashes, FHWA commissioned a detailed study of North Carolina emergency room (ER) admissions due to bicycle accidents (Ref. 11). Of the 649 admissions to the ER, the study found that 48 % of the accidents took place on a public street, and 20 % involved a motor vehicle; yet only 12 % had reported the accident to the police. Those bicyclists involved with a motor vehicle were more likely to have reported the accident, but still only 60 % (67 out of 112) did so. Of those that did not involve a motor vehicle, only 1 out of 537 reported the accident to the police.

The characteristics of these unreported bicycle accidents were studied, and contributing factors to the accidents were determined. Four are of interest to traffic engineers: 27 % involved an uneven surface, 15% a slippery surface, 15% were collisions with a moving object, and 13% were collisions with a non-moving object. These findings were very similar to those of other studies of bicycle crashes. A survey of 3,000 bicyclists in Ottawa and Toronto found (Ref. 12):

- Ten percent of Toronto's and 15 % of Ottawa's bike collisions were reported to police.
- About 5 % occurred on sidewalks, none of which were reported to police.
- Risk of fall or injury on sidewalks is greater than for roads or paths.
- Bicyclists who ride on the sidewalk have higher crash rates on roads and paths as well.

A survey of almost 2,000 adult cyclists were asked in 1996 about their route choice, accident history, and location of the accident, i.e. road, bike lane, bike path sidewalk. These data were compared to a previous survey conducted by the League of American Bicyclists in 1975 (LAB 75) and a survey of Washington State cyclists (WA '94). The studies determined the number of crashes and the total number of miles ridden on each of the various facility types. The fraction

**Table 21-2—Primary Sources of Bicycle Accident Information**

Data Source	Type of Collision Statistics	Contacts
<b>Federal</b>		
Fatal Accident Reporting System (FARS)	Fatal motor vehicle accidents on public roads; compiled from state, police, and hospital records.	<a href="http://www.nhtsa.dot.gov/people/nca">www.nhtsa.dot.gov/people/nca</a> ; web query and cd rom available
National Center for Statistics & Analysis (NCSA), National Highway Traffic Safety Administration (NHTSA)	Injury accidents and total injuries from traffic crashes sorted for various factors including mode, passengers, alcohol, age, safety devices. National estimates developed using the General Estimates System (GES), a random sample of police-reported motor vehicle crashes.	202-366-4198 <a href="http://www.nhtsa.dot.gov/people/nca">www.nhtsa.dot.gov/people/nca</a>  <a href="http://www-nrd.nhtsa.dot.gov/departments/nrd-30/nca/SDS.html">www-nrd.nhtsa.dot.gov/departments/nrd-30/nca/SDS.html</a>
National Electronic Injury Surveillance System, (NEISS), Consumer Product Safety Commission	Hospital emergency room statistics.	<a href="http://www.cpsc.about.com/clearinghouse">www.cpsc.about.com/clearinghouse</a> <a href="mailto:clearinghouse@cpsc.gov">clearinghouse@cpsc.gov</a> 1-800-638-cpsc
<b>State</b>		
State of California – California Highway Patrol (CHP) SWITRS Report 7 - Bicycle accidents	Compiled by CHP from police reports sent by local agencies, consequently includes only reported accidents investigated by a police officer. • (Only injury accidents are required to be reported to SWITRS).	CHP sends quarterly report to each city's public works or traffic engineering department Also available at: <a href="http://www.chp.ca.gov">www.chp.ca.gov</a>
<b>Local</b>		
Local Police Departments	Accident database, includes all reported collisions including counter reports and non-injury and property damage only. Varies by police dept.	Varies
Hospitals	Hospital emergency room statistics.	Varies

of crashes per facility type was then divided into the fraction of miles ridden on that facility type to determine the "relative danger index" (RDI). An RDI of 1.0 indicates that the crashes occurred in proportion to the number of miles ridden, and greater than 1.0 indicates that crashes occur at a higher rate than would be expected. The results of the three studies are presented in Table 21-4 (Ref. 13). Note that inconsistency in terminology and data aggregation between the studies leaves some cells of the table blank. These surveys found consistently that crash rates on bike routes and bike lanes are significantly lower than on all other facility types.

- 2 **Bicycle Crash Types.** A seminal study of bicycle crashes by Cross and Fisher (Ref. 14) in the mid 1970s identified 37 bicycle crash types within seven main categories. This study was updated by FHWA in 1995 (Ref. 15) with an analysis of 3,000 bike crashes in six states, and the findings were compared to the original study. NHTSA researchers felt that these crash types needed further refinement to better describe the conditions and to simplify the system so that there would be more consistency nationwide. Therefore the data from the 1996 study were also classified with the new crash typing scheme as shown in Table 21-5.

Based on the 1996 study, nationwide the top 4 accident subtypes, comprising 25% of all collisions, are:

- Motorist left-turn into path of oncoming bicyclist 5.9 %
- Motorist failed to yield or stop to cyclist at STOP sign or red-light 8.1%
- Bicyclist failed to yield-Rideout from residential driveway 5.1%
- Bicyclist failed to yield or STOP at STOP sign or red-light 6.4%

**Table 21-3—Comparison of Reported Collisions With Hospital Records of Bicycle Fatalities and Injuries in the United States**

Year	Bicycle Fatalities in MV Crashes <sup>1</sup>	Bicycle Injuries in MV Crashes <sup>1</sup>	Bicycle-Related Hospital ER Visits <sup>2</sup>
2001	728	45000	NA
2000	690	51000	627,164
1999	754	51000	NA
1998	760	53000	NA
1997	813	58,000	567,002
1996	765	59,000	566,085
1995	833	67,000	586,808
1994	802	62,000	604,567
1993	816	68,000	604,066
1992	723	63,000	649,673
1991	843	67,000	601,172
1990	859	75,000	580,119

1. MV – motor vehicle. Source: "2001- Traffic Safety Facts", National Highway Traffic Safety Administration, Washington DC.

2. Source: "Product Summary Report", National Electronic Injury Surveillance System, U.S. Consumer Product Safety Commission

**Table 21-4—Relative Danger Index of Bike Facilities**

	LAB '96	WA '94	LAB '75
Major street w/o bike facilities	0.66	0.75	1.00
Minor street w/o bike facilities	0.94	0.98	0.92
Signed bike route only	0.51	NA	NA
On-street bike	0.41	NA	NA
On-street bike facilities (bike route or bike lane)	NA	0.54	0.53
Multi-use trail	1.39	1.03	2.71
Off-road/unpaved	4.49	8.58	NA
Other (most often sidewalk)	16.34	NA	NA

*Relative danger index of 1.0 indicates crashes occur in proportion to distance traveled.*

**Table 21-5—NHTSA Crash Typing Scheme**

Subgroup	% of all crashes	Number of subtypes
Specific Circumstances	7.0	9
<b>Parallel paths</b>		
Motorist turn/merge into path of bicyclist	12.2	6
Bicyclist turn/merge into path of motorist	7.3	5
Operator on wrong side of street	2.8	3
Motorist overtaking the bicyclist	8.6	6
Bicyclist overtaking the motorist	2.7	5
Motorist lost control	0.6	6
Bicyclist lost control	1.2	6
<b>Crossing paths</b>		
Bicyclist did not clear intersection	1.4	2
Motorist failed to yield	21.7	10
Bicyclist failed to yield-midblock	11.8	10
Bicyclist failed to yield-intersection	16.8	6
Motorist turning error	0.6	2
Bicyclist turning error	0.7	2
Crash occurred at an intersection	2.9	2
Unknown /insufficient information	1.7	3

3 **Crash analysis.** The proportion of individual crash types within a particular community will vary depending on the demographics, roadway types, and roadway design, and on whether the community is urban, suburban, or rural. For example, Fig. 21-2 shows the most common bicycle crash types for a typical city and a typical suburb in California. Cities tend to have more dooring accidents (bikes in collision with opening door of parked car), while suburbs tend to have more wrong-way riding accidents.

In order to develop effective countermeasures the crash statistics should be sorted to find a commonality among certain crash types.

- a. *Identify the cause of the collision.* The California SWITRS has fields for "primary collision factor" and for "section of CVC [Ref. 16] violated." Frequently the latter is more informative as to the cause of the collision. Whenever possible, it is advisable to read the police reports. Often, the SWITRS summary does not contain pertinent information, such as whether sidewalk riding was involved, or if a third party contributed to, but was not directly involved, in the collision. For example, an accident was coded as a pedestrian-bike accident, but a review of the police report revealed that a bus did not pull over to the edge of the road, so when the "pedestrian" got off the bus, a bike passing the bus on its right struck the pedestrian.
- b. *Determine age and party at fault in order to focus education efforts.* The accident types should then be stratified by age and other factors to determine any patterns. Determining the parties at fault and age of cyclists will help to focus education efforts. For example, an analysis in Cupertino, CA revealed that, of bicycle accidents involving children under 16, roughly 60% were the fault of the child bicyclists, whereas of bike accidents involving adult bicyclists, 80% were the fault of the motorist. The focus of any outreach in Cupertino, therefore, should be children and motorists rather than adult cyclists.

Adults and children also differ in the types of crashes in which they are involved (Fig. 21-3).

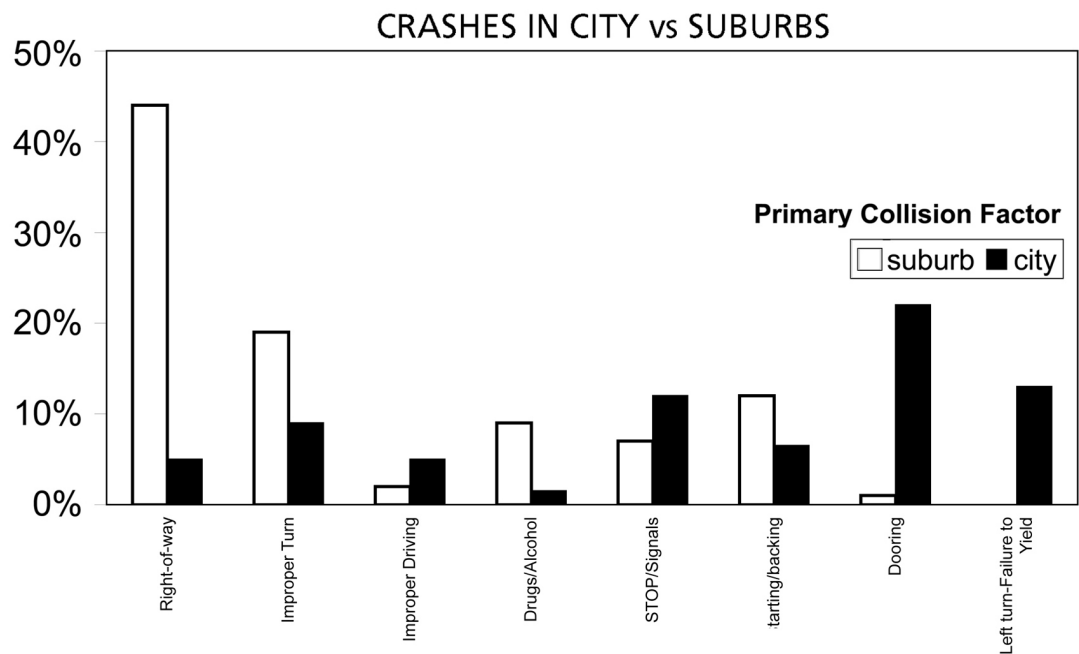

Source: Wilbur Smith Associates

**Fig. 21-2-Crashes in City vs Suburbs**

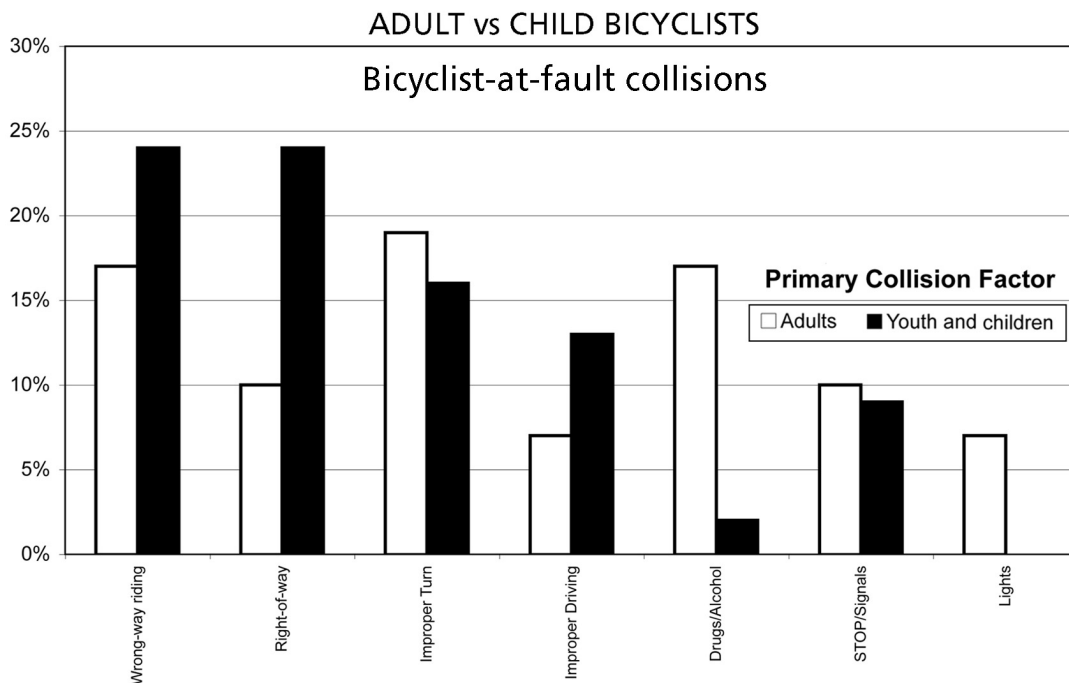

Source: Wilbur Smith Associates

**Fig. 21-3-Adult vs Child Bicyclists in Bicycle-at-Fault Accidents**

Recommended venues for education:

- Motorists – driver education class, traffic school focusing on bicycle issues
- Adult Bicyclists (age 16 and older) – employers, bike shops, bike clubs, community events
- Child Bicyclists (under 16) – school curricula, bicycle rodeos

c. *Determine Location.* Are there clusters of collisions in certain intersections or along a certain street or street type? If there are intersection hot spots, a common countermeasure is to improve sight distance. If an arterial has a disproportionate number of incidents, then the design issues discussed in section F should be reviewed. If crashes cluster near high schools, then a combination of engineering and education may be necessary, e.g., engineering where appropriate, education to reach young drivers in the areas, and/or reduction of high school student parking privileges. A cluster of nighttime accidents at one location may indicate the need to improve street lighting as well as to educate bicyclists to use headlights and taillights.

4 **Countermeasures by crash type.** Typical countermeasures are presented below for common motorist-at-fault and bicyclist-at-fault crashes.

a. **Motorist at fault**

(1) Opening car door into path of bicyclist. (CVC 22517)

Potential countermeasures:

- Wider curb lanes
- Provide bike/parking lane at least 3.65 m wide (4 m is better)
- Extend parking tees outward to 3 m
- Prohibit parking

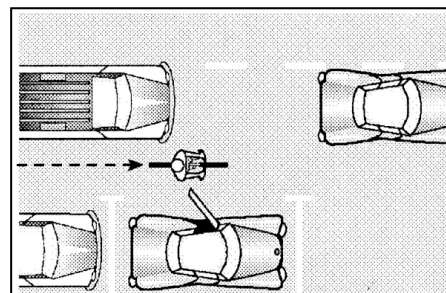

(2) Right turn when unsafe (CVC 22107) Potential countermeasures:

- Prohibit right turn on red
- Dash/Drop bike lane stripe at intersection approach
- At right-turn-only lane, provide through bike lane
- Do not stripe shoulder to the right of outside lane

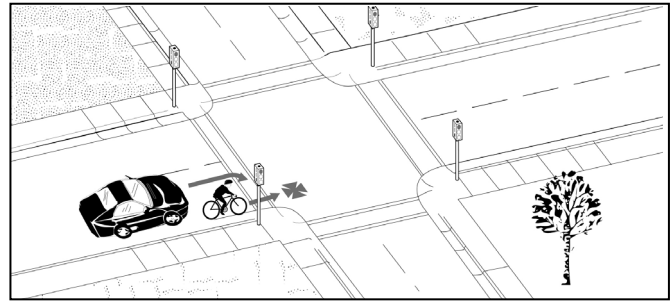

(3) Left turn (CVC 21801) Potential countermeasures:

- Provide left turn pockets
- Protected left turn signal phasing
- Improve intersection design

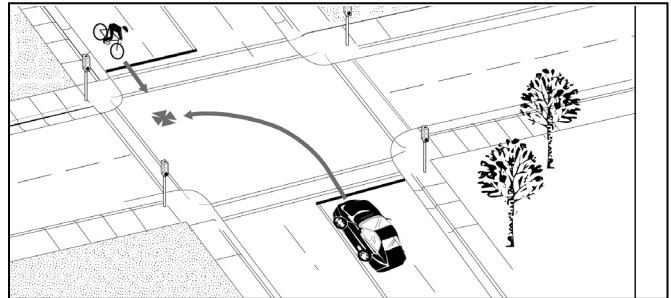

(4) Right turn across a bike lane (CVC 21717) Potential countermeasures:

- Prohibit right turn on red
- At right-turn-only lane, provide through bike lane
- Dash or drop bike lane stripe in advance of intersection
- Install MUTCD (Ref. 17a) R4-4 "Begin right turn lane, yield to bikes"

b. **Bicyclist at fault**

(1) Bicyclist not operating in same direction as traffic (CVC 21650)

Potential countermeasures:

- Bike lanes or wide curb lanes
- Install arrows in existing bike lanes
- Install wrong way signs on reverse side of bike lane signs
- Install wrong way signs on sidewalks

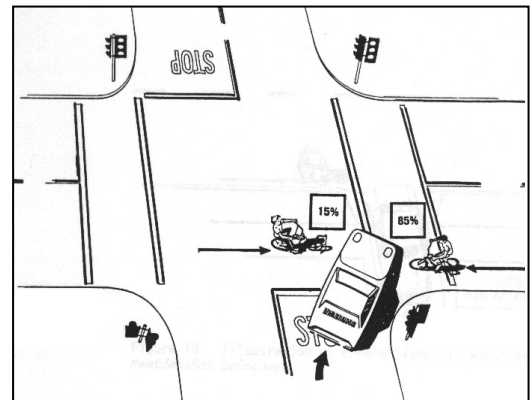

(2) Bicyclists rideout-controlled intersection

Potential countermeasures:

- Lengthen yellow phase (signal)
- Evaluate STOP sign placement to give priority to bike route, if possible

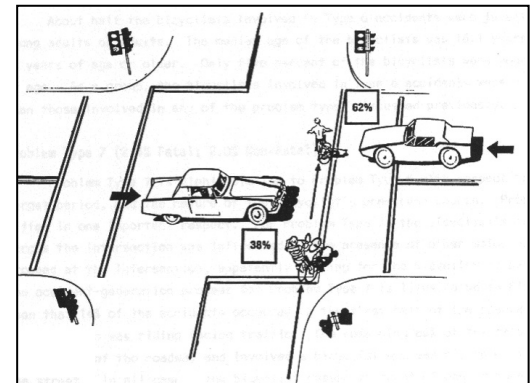

## D. Legal Context

### 1 Vehicle Codes

- a. *Bicyclists' Rights to the Road.* While the California Vehicle Code (CVC) specifically excludes bicycles from the definition of vehicle, many states do classify bicycles as "vehicles." In either case, all states but Massachusetts grant cyclists the same rights and duties as drivers of vehicles. A common version of this basic rule is (Ref. 18):

"Every person operating a bicycle upon a roadway has all the rights and is subject to all the duties applicable to the driver of any other vehicle as set out in this chapter, in addition to special regulations in this chapter, except as to those provisions of this chapter which by their nature have no application."

For comparison, CVC 21200 reads: "Every person riding a bicycle upon a highway has all the rights and is subject to all the provisions applicable to the driver of a vehicle ....except those which by their very nature can have no application."

Local AAA offices often provide a pamphlet outlining the bicycle laws in that state. In California bicyclists are permitted to ride on every roadway with the exception of some freeways and those toll bridges that do not provide access to bicycles via a dedicated bike path. Freeways must be posted when they are not open to bicycles, since they may be open when approved by local authorities in conjunction with Caltrans, as described in the *Highway Design Manual (HDM)*, Ref. 8.

Local authorities in California may regulate the use of bikes on sidewalks. Such ordinances are typically worded to permit the use of sidewalks in residential areas by children. However, the *HDM* does not allow a local authority to force bikes to use sidewalks instead of the roadway. This would in effect be the controversial and unsafe "sidepath" rule which required bicycles to use a path adjacent to the roadway if there was one. Most states repealed this rule in the 1970s and 1980s in response to serious objections raised by cyclists and the liability exposure which resulted from mandatory use of such facilities. The issues that make sidepath riding problematic are the same as those that make sidewalk riding unsuitable (see Sec. F.1.a.); unfortunately, however, 18 states still attempt to regulate the use of the roadway by use of the mandatory sidepath law. These laws should be repealed.

- b. *Regulating Bikes on the Road.* The CVC—and codes of many other states—specifies that, when riding on the roadway at a speed less than the normal speed of traffic, the bicyclist must ride as "close as practicable to the right-hand curb or edge" with logical and practical exceptions, such as overtaking or passing, preparing for a left-turn, and avoiding unsafe conditions.

In California, the only type of vehicle permitted to be driven on the shoulder is a bicycle. On the other hand, four states *require* bicycles to use the shoulder unless it is full of debris or otherwise unavailable.

- c. *Safety Equipment Regulation.* Helmet requirements vary from state to state. Currently, 19 states require children riding a bicycle to wear a helmet, although the defined age varies. In California, the age is under 18. All states require a headlamp of varying strength, 5 require a red tail light, and the remaining require a reflector. Rules for pedal reflectors and side reflectors vary from state to state.

- 2 **Highway Codes and Other Legislation.** California legislation to ensure a bicycle transportation network is mentioned in E.1.b. below.

- 3 **Liability.** The discussion of liability in Chap. 33 also applies to bikeway design and roadway design with respect to bicycles. Design immunity covers most states but liability can be incurred when the project is not built to the specified design. More commonly for bicycles, liability is incurred for maintenance deficiencies or if there is failure to improve a facility over time.

- a. *Bikeway designation.* While one researcher determined that the designation of bikeways does not increase liability (Ref. 19), many risk managers maintain that the formal designation of bicycle routes does increase potential liability (Ref. 20). Bicycles present a

greater challenge than four-wheeled vehicles because they are much more sensitive to roadway imperfections and to design features, such as expansion joints or rumble strips. The transportation agency must exercise a standard of care, particularly regarding maintenance and upgrades. When sufficient funds are not available, having a plan that documents the phasing of improvements is a legitimate defense. If the agency works within its expertise, solicits input from affected agencies, and documents what actions it takes and why it is taking them, it would be demonstrating the standard of care being taken.

- b. *Signs not contained in the MUTCD* (Ref. 17a). The *Standard Highway Signs* book (Ref. 17b) contains frequently-used designs that are not found in the *MUTCD*, and the *California Supplement to MUTCD* has many more. The use of signs that are not contained in these manuals is one of the more common bike-related questions about liability. The desire for more signs is evidenced by the variety of other signs across California and the country, particularly variations on the "Share the Road" message, but also "Except Bikes" supplementary plate (e.g. DO NOT ENTER EXCEPT BIKES), "Railroad Track Warning", and "Trail Xing" signs (Ref. 21). A strict interpretation is that these are "nonstandard" signs, while the users of these signs and plates maintain that they are standard because they conform to the shape and color of standard signs of the same functional type.

For the federal process of testing and adopting new signs, see Chap. 13, Sec. C.4. The language in the *California Supplement to the MUTCD* (Ref. 17c) is similar, if not more direct. Sec. 2A.06, "Design of Signs", states: "Signs other than those shown in these publications" [the *Standard Highway Sign Book* and Caltrans' *Traffic Sign Specifications*], the *MUTCD* or the *California Supplement* may be required under special conditions."

## E. Planning and Policies

- 1 **Policies.** Many of the most effective policies that define a bicycle transportation system either allocate funds or attach some restrictions on what an agency must do to receive funds. Such policies have not only increased the quantity of bicycle projects; they have improved the quality and effectiveness of projects being funded and implemented.

- a. *Federal.* In 1991, ISTEA heralded a departure in federal policy. For the first time legislation mandated that bicycling and walking modes must be considered in transportation projects. Bicycle projects are now eligible for many spending programs, including Surface Transportation Program (STP), Congestion Management and Air Quality (CMAQ), and Transportation Enhancement (TE) programs. ISTEA/TEA 21 required every state DOT to have a full-time bicycle and pedestrian coordinator.

Another important new federal policy was the 1994 National Bicycling and Walking Study. This contained two overall goals: to double the percentage of total trips made by bicycling and walking in the United States from 7.9% to 15.8% of all travel trips; and to simultaneously reduce by 10% the number of bicyclists and pedestrians killed or injured in traffic crashes.

- b. *State.* In California, the legislature "finds that the increased use of the bicycle is a desirable activity which should be encouraged by the improvement of access available to that mode of transportation." (Ref. 22, §30112). *The Streets and Highways Code* (CSHC) provides (Ref. 22):
  - Caltrans shall not sever or destroy an existing route for non-motorized traffic when designing new freeways, (CSHC § 888), and shall incorporate non-motorized transportation facilities in the design of freeways and toll bridges along corridors where such facilities do not exist, [if] the facilities would conform to the California Recreational Trails System Plan or to the master plans of local agencies. [Caltrans] shall establish an annual priority list of projects to be funded, which shall primarily benefit bicyclists rather than other highway users (§888.2).
  - Cities, counties, or local agencies shall not abandon rights-of-way established for other purposes unless the governing body determines that the whole or parts are not



useful as a non-motorized transportation facility. (§892(a)). Caltrans must consult with local agencies before it abandons any state highway right-of-way to determine whether part or all of it could be developed as a non-motorized transportation facility. If an affirmative determination is made, Caltrans first makes the property available to local agencies for such development (§892(b)).

- It is the policy of the state to acquire abandoned railroad lines when the right-of-way for such lines has a potential public transportation use including a use for bicycles and/or pedestrians (§2540).

Caltrans Directive 64, "Accommodating Non Motorized Travel" (2001), spells out how these sections of the law are to be implemented.

In California, projects funded by the Bicycle Transportation Account (BTA), must be included in an adopted Bicycle Plan (Ref. 22, §891). This policy has significantly increased the number of California communities that have developed bicycle plans. The required elements of a Bicycle Plan are presented in the next section.

In 2002, Caltrans released the "California Blueprint For Bicycling And Walking" as part of its report to the legislature. This contains the following goals: increase bicycling trips by 50% by 2010; decrease bicycling fatality rates by 50% by 2010; and increase funding for bike facilities.

Oregon House Bill 1700 (9/15/91) requires that, wherever highways, roads or streets are being constructed, reconstructed, or relocated, footpaths and bicycle trails will be built, including curb cuts or ramps, as part of these projects. The law further requires that the amount expended by the highway division on such projects shall never in one fiscal year be less than 1%.

- Local.* In California, Regional Transportation Planning Agencies (RTPA) distribute the return-to-source (TDA Article 3) funds for bicycle and pedestrian projects. In the San Francisco Bay Area, the Metropolitan Transportation Commission requires that, in order to spend these funds on a bike project, it must be included in a bike plan and must be approved by a local bicycle advisory committee.

## 2 Planning

- Purpose.* Bicycling was historically (pre-ISTEA) left out of many transportation plans because it was thought that either bicycling did not seriously affect the capacity of other modes or there were too few bicyclists for bikeways to have serious capacity issues. Thus, even at preliminary planning stages, bicycle data — e.g. turning movement counts at intersections, travel time studies, questions on bike trips — were often not collected in travel behavior surveys. As a result, there was often no consideration of how to provide basic accommodation for bicyclists on roadways, let alone how to improve the bicycling network for existing and future bicyclists.

The benefits of bicycle planning are the same as for other modes: the community is better served when there are many feasible modal options. Projects can be constructed at a lower cost when all modes are considered from the beginning rather than being retrofitted afterward. Examples of cost savings from good planning are: reserving an abandoned rail right-of-way or acquiring an easement along a river or creek for a multi-use path; implementing bike lanes after a roadway resurfacing project; providing wide shoulders or a bike lane along the frontage of a new development.

Bicycle travel is affected by man-made conditions, such as land use patterns and street layouts. Chap. 12 discusses the latter.

- Bicycle Travel Forecasting.* Bicycling is not typically included in travel forecasting models for the same reasons it historically was not included in city planning: capacity is usually not an issue. Some existing models do, however, include bicycle trips in the trip table; they are just not assigned to the network. This information is still useful for many reasons. Mode split trends can be tracked and updated with the census and other surveys. Bicycle-km of travel can be computed to help inform other planning and funding decisions. For example, the

Alameda Countywide Bicycle Plan was able to calculate the number of bicycle trips and bicycle-km of travel for each city within the county from the countywide model. These were then used to determine bicycle crash rates for each city. Based on absolute numbers of bicycle accidents, the city of Berkeley was the worst city in the county, three times the county average. But when accidents were normalized by bicycle trips and bicycle-km traveled, three other communities had nearly the same rate of bike crashes per bicycle trip.

Ref. 23 contains a list of factors that affect bicycling and help the modeler to include bikes as a mode choice. Many of these factors, e.g., supporting policies, climate, and population characteristics, are specific to non-motorized modes. In general, bicycling is most feasible and therefore can be expected at higher than average levels in the following circumstances:

- Trips shorter than 6 miles.
  - Where roadway capacity is seriously limited, thus making the travel times of the two modes more equal.
  - Where parking supply is limited, making bicycling a more attractive option.
  - Trips to transit/train stations.
  - Trips requiring transport of packages too heavy or awkward to carry by walking.
  - Trips to parks or on roads of scenic beauty.
- c. *Bicycle Master Plans.* A bicycle master plan will develop community goals and priorities, identify needed projects, preserve rights-of-way, and prepare the agency to apply for grant funding. Many statewide plans are available on websites. Cities and counties, large and small, ranging from Los Altos, to Los Angeles, have adopted bicycle master plans. There are bicycle master plans for Houston, Tucson, Philadelphia, Toronto, Seattle, and San Francisco – a geographically and climatically diverse list.

A Bicycle Master Plan in California also satisfies the requirement for Transportation Funds for Clean Air (TFCA) and the Transportation Development Act (TDA) Article 3 account. Many MPOs will give extra points when allocating federal funds such as CMAQ or TEA if a project is included in a master plan.

A typical Bicycle Master Plan includes most or all of the following elements. Those with asterisks are required if a project is to be funded by BTA.

- Goals, policies, and action steps
- Public surveys
- Data collection: background ADTs, 85<sup>th</sup> percentile speeds, bicycle counts
- Accident analysis: by location, by party-at-fault, by collision type
- Existing travel behavior and mode splits by trip purpose\*
- Existing and proposed land use attractors and generators\*
- Existing and proposed bikeways (by type) and bicycle parking facilities\*
- Existing and proposed bicycle interface with public transportation modes\*
- Existing and proposed facilities for changing and storing clothes and equipment and showers.\*
- Existing bicycle safety and education programs; efforts by the law enforcement agencies and the resulting effect on accidents involving bicyclists\*
- Public workshops–community outreach
- Description of the extent of citizen and community involvement, including, but not limited to, letters of support.\*

- Consistency with other local or regional transportation, air quality, or energy conservation plans\*
  - Description of the proposed projects and a prioritized list of projects\*
  - Past expenditures for bicycle facilities\*
  - Estimated cost of recommended plans and projects\*
  - Map of bicycle network for public distribution
- d. *Bicycling and Traffic Impact Studies.* The existing Transportation/Circulation section of the California CEQA Initial Study Checklist asks only one question related to "alternative" transportation: "Conflicts with adopted policies, plans or programs supporting alternative transportation (e.g., bus turnouts, bicycle racks)?"

However, other criteria should be analyzed in order to assess the effect of a project on bicycling conditions. In addition, there is often a conflict between accommodating bicycling and mitigation measures prescribed for motor vehicle impacts, such as, providing more traffic lanes by eliminating a bike lane, or even less obvious actions such as retiming signals or providing a right-turn lane. Potential adverse impacts on bicycling conditions should be assessed at the initial study phase of the project and again at the mitigation phase, using the following five standards of significance on bicycling circulation, access, and safety:

- (1) Consistency with General Plan and Bicycle Plan
- (2) Bicycle circulation: will direct travel be impeded by changes in the roadway network?
- (3) Will the existing bikeway system be affected by
  - increasing the ADT on a designated bikeway or crossing a trail at-grade?
  - changing the width, length, or surface conditions of the bike lane, trail, or route?
  - changing the bike lane striping at an intersection approach due to a new right-turn lane?
  - adding new STOP signs or signals along a designated bikeway?
  - increasing the number of at-grade crossings of a bicycle trail?
- (4) Will roadways used by bicycles restrict or reduce bicyclists' operation space by
  - reducing width of the roadway, travel lane, shoulder, overpass or underpass?
  - creating new edge of roadway obstructions: utility covers, gutter seams, grates?
  - increasing bike delay at signals due to longer cycles, inadequate bike detection, etc.?
- (5) New construction: will the project meet or exceed accepted bikeway design standards?

## F. Bicycle Facilities On Roadways

This section addresses roadway design of bike lanes, bike routes and undesignated roads. Bike paths and shared-use paths are discussed in Sec. G.

The two most important manuals are the AASHTO *Guide for the Development of Bicycle Facilities*, 1999 (Ref. 6) and, for California, Chapter 1000 of the Caltrans *Highway Design Manual (HDM)* (Ref. 8). While similar in most respects, they differ in terminology: Ref. 6 uses Bike Path, Bike Lane, and Bike Route for the three classes of facilities; Ref. 8 uses Shared Use Path, Bike Lane, and Signed Shared Roadway. This section summarizes the key design points from these two manuals, supplements the information with material from other documents, and provides references for the reader to find further coverage of a specific topic.

Both manuals also contain a discussion of general roadway design issues that affect bicycling regardless of whether a bikeway is established, because bicycles may be present on virtually all roadway types. Both call this an undesignated shared roadway. These issues are summarized below.

1 General Roadway Design Issues.

a. *Differences Between Bicyclist and Pedestrian Requirements.* Bicyclists have different operational characteristics from pedestrians that affect the design of bicycle facilities. First, the design speed for bikes is much greater than for pedestrians, and for safety reasons it is better to separate the two modes except in special circumstances. Stopping sight distance, horizontal curvature, and other design elements associated with speed are factors for bikeways. The design guidelines for one mode are not necessarily appropriate for the other mode.

Both the *HDM* and the AASHTO Guide strongly discourage the designation of sidewalks as bikeways. Bicyclists would need to ride slowly to avoid colliding with pedestrians. In addition, there are severe safety issues when bicyclists enter intersections from sidewalks as well as risks at every driveway. This is not to say that sidewalk bike riding should be prohibited in residential areas. In general, however, sidewalks should not be signed as bike routes or bike paths. If a sidewalk is free of intervening driveways and intersections, meets the design standards of a bike path including separation from motor vehicle traffic, and closes a gap in a bikeway, then it might be appropriate to be considered a shared-use path instead of a sidewalk. For further discussion on the concerns presented by sidewalk bikeways, see Ref. 8, §1003.3(2) and Ref. 6 (AASHTO), pp. 20 and 58.

b. *Issues Important to Bicycling.* The roadway, bike lane, or shoulder surface should be free of surface interruptions that would pose an impediment to bicyclists. The most common are drainage grates, railroad tracks, utility covers, and construction plates. The vertical deviation between the pavement surface and these objects should be minimized. Table 21-6 lists the maximum recommended variations in the pavement surface of existing streets to minimize the potential for causing bicyclists to lose control of their bicycles. The *HDM* adds that stricter tolerances should be achieved on new construction.

- Bicycle speeds: For design purposes, where speeds need to be assumed, the values in Table 21-7 may be used.
- Drainage design: Grates must conform to California Standard Plans D77-B (unless bicycles are prohibited from the roadway, e.g. a freeway). Storm drain inlets without grates (e.g., curb opening inlets), are better and are appropriate where roadway grades are 3% or less (described in more detail in *HDM* §837.1). If there is no curb and gutter, where possible, locate the grate off the shoulder.

**Table 21-6–Bikeway Surface Tolerances**

	Grooves <sup>1</sup>	Steps <sup>2</sup>
Parallel to travel	No more than 12.5mm wide	No more than 10mm high
Perpendicular to travel	–	No more than 20mm high

1: Groove - narrow slot in the surface that could catch a bicycle wheel, e.g. a gap between two concrete slabs.

2: Step - a ridge in the pavement, e.g as might exist between the pavement and a concrete gutter or manhole cover.

Source: Metric version of Caltrans HDM Table 1003.6

**Table 21-7–Representative Bicyclist Speeds**

Bicyclist Population	Average Speed	15th Percentile Speed (85% of cyclists)	2nd Percentile Speed (98% of cyclists)
Fast or commuter	29 kph (8 m/sec)	23 kph (6.5 m/sec)	19 kph (5.5 m/sec)
Casual adult	19 kph (5.5 m/sec)	16 kph (4.5 m/sec)	13 kph (3.5 m/sec)
Children	14 kph (4 m/sec)	11 kph (3 m/sec)	10 kph (2.8 m/sec)

Source: Alan Wachtel et al. "Signal Clearance Timing for Bicyclists". ITE Journal March 1995.

- Railroad tracks: Asphalt crossings of railroad tracks tend to buckle, and ridges build up over time. Concrete surfaces are stronger and preferable to asphalt. Some jurisdictions have had positive experience with rubberized rail crossings. Where tracks are skewed to the direction of travel of the bicyclist, it is beneficial to widen the bikeway approach so that a right-angle crossing can be made.
  - Metal plates: A beveled edge, particularly on construction plates, makes it easier to achieve the surface tolerance limit of 20 mm. Utility covers and construction plates should have a minimum coefficient of friction of 0.35. (Plain steel plates have an unacceptably low coefficient of friction and should never be used on the roadway). An effective method to achieve skid resistance on covers and plates (both steel and concrete) is for the manufacturer to imprint waffle-shaped patterns or right-angle undulations on the surface.
  - Obstructions: If there are unavoidable vertical barriers and obstructions such as abutments or piers on the edge of the roadway or shoulder, they should be clearly marked to warn approaching bicyclists. See example in *HDM* Fig. 1003.6B.
- c. *Maintenance Issues Important to Bicycling.* Two maintenance activities that affect bicycling are pavement resurfacing with respect to the concrete gutter seam, and trench and pothole filling. Increased attention to the right-hand portion of roadways where bicyclists are expected to ride is important. In particular:
- Asphalt overlay procedures. Grind asphalt at edge of roadway prior to applying the overlay to ensure a smooth longitudinal gutter joint. A wedge cut that accomplishes this is illustrated in Fig. M-1 of the *VTA Bicycle Technical Guidelines* (Ref. 24).
  - Trench and pothole patching procedures. Compaction standards from Caltrans Standard Specification 39-6.03 should be met to ensure that the pavement surface remains intact and smooth after the project is completed. When performed by an outside contractor, require inspection 12 months after project is completed to ensure that the patch has held up.

- 2 **Bike Lane.** The bike lane provides a striped lane for one-way bike travel and is for the exclusive use of bicycles with certain exceptions: right-turning vehicles must merge into the bike lane prior to turning, and pedestrians are allowed to use the bike lane when there is no adjacent sidewalk (Ref. 16, §21717 and 21966).

Surveys show that most bicyclists prefer to ride in a bike lane rather than a wide curb lane on busy roads. Also, studies of bike lanes in various parts of the country indicate that the presence of properly designed bike lanes increases the amount of bicycling, decreases the incidence of sidewalk bicycling, and reduces bicycle crash rates (Refs. 25, 26). Bike lanes are appropriate on all new arterials and on collectors above 4,000 vpd. Below this traffic volume, there should be adequate gaps in oncoming traffic for motor vehicles to safely pass bicyclists. Retrofitting bike lanes on existing roadways is much more challenging. Options are discussed below under F.2.e.

- a. *Geometric Design of Bike Lanes.* While grade and curvature of bike lanes are those of the street itself, a severe grade may affect their use. If the downhill grade and/or length of the grade will enable bicycle traffic to travel at the flow of traffic for more than a block, then bike lanes may be counterproductive. Consider a wide shared lane instead as discussed below in F.3.

The minimum width of bike lanes depends on the presence or absence of curb, gutter, and on-street parking. The *Highway Design Manual* specifies the minimum width for bike lanes under three conditions:

- Bike lane next to a curb: on-street parking prohibited. Minimum width is 1.2 m with the proviso that there is at least 0.9 m to the longitudinal joint where the asphalt meets the gutter pan. This equates to 1.5 m with a typical 0.6 m gutter pan and 1.2 m with a 0.3 m gutter pan.

- Bike lane on roadways without curb and gutter. Where infrequent parking is handled off the pavement, the minimum width is 1.2 m.
- Bike lane next to a curb: on street parking allowed. Minimum width is 1.5 m where there is a vertical curb, and the parking stalls or a continuous parking stripe are marked. Where parking or turnover is infrequent, and no parking stalls are marked, 3.6 m is the minimum (unless there is a rolled curb, when 3.3 m is the minimum.)

Both design manuals advise wider bike lanes wherever possible and where the speed of adjacent traffic is high, or substantial truck traffic is present. Recommendations from Santa Clara County are presented in Table 21-8:

**Table 21-8—Optimum Bike Lane Widths**

Posted Speed (kph)	Without parking (m)	With parking (m)
0 – 55	1.5	4.0
55 – 80	1.8	4.3
80+	2.4	4.9

Source VTA Bicycle Technical Guidelines Table 2

Raised barriers (e.g., traffic bars or asphalt concrete dikes) shall not be used to delineate bike lanes because raised barriers:

- prevent motorists from merging into bike lanes before making right turns, as required by the Vehicle Code.
  - restrict bicyclists from entering or exiting bike lanes.
  - impede routine maintenance.
  - may cause a bicyclist to slip when entering or exiting bike lanes
- b. *Bike Lane Signs.* The bike lane sign (CA-R81 or MUTCD R3-17) is placed after every major intersection and approximately every 0.75 km. The rear of the bike lane sign can be supplemented with the MUTCD R5-1b sign to discourage wrong way bike riding.
- c. *Markings.* The 2003 MUTCD and the 2003 Caltrans *Supplement* currently differ in the recommended marking of a bike lane. In California, the BIKE LANE word message marking is the standard and the "arrow" and "symbol" markings are optional as shown in Ref. 17c, Fig. 9C-105. The 2003 MUTCD (Ref. 17a) is essentially the reverse: the "arrow and symbol" are standard and the BIKE LANE word message is optional. There are two approved bike symbols: a "bike" alone and a "bike with rider." Also in California, the longitudinal bike lane stripe is 15 mm wide while in the MUTCD it is 10-15 mm.

The markings should be placed immediately after an intersection and may be installed without the signs to avoid overuse of signs.

- d. *Intersection Design.* The key design issue at intersections is the treatment provided to facilitate the weave that takes place between through bicyclists and right-turning vehicles.

Typically, a bike lane at intersections is dropped or "dashed" ahead of the intersection approach in order to cue both right-turning motorists and through bicyclists. They must weave across each others' paths in order to be correctly positioned to turn right or continue straight respectively. The stripe should be dropped or dashed 60 m in advance on streets with travel speeds greater than or equal to 60 kph while on streets with 30-50 kph travel speeds, 30 m is acceptable. Whether to drop or dash is up to engineering judgment.

- (1) *Right-turn lanes.* A bicyclist traveling straight ahead must ride in the through lane to the left of the right-turn lane to avoid being hit by the right-turning vehicle. Often, lane widths are reduced to provide the right-turn lane, which exacerbates the positioning of the bicyclist. Optimally, a bike lane would be maintained to the left of the right-turn lane; several bike lane situations are illustrated in Refs. 8 and 24. If a bike lane is not possible, provide a through lane 3.7 to 4.3 m wide next to the right-turn lane for sharing by motorists and bicyclists.

- (2) Channelized ("free") right turns. Right-turn channelization with a pork chop island can be problematic when designed to facilitate motor vehicle right turns at higher speeds; this makes the weave between the through bicyclists and the right-turning motor vehicles more difficult. Such channelization is not recommended as a norm but only where useful in reducing the pedestrian walking time across wide arterials.
  - (3) Oblique right-turn lanes. Intersections or ramps that involve a turn of less than 90° may allow motorists to turn right without slowing. Motorists do not have a clear sense of turning right and thus may fail to look for bicyclists or to use their turn signals. To slow motorists, design elements can be incorporated into these intersections, such as making the turn closer to 90°. See Chap. 18, C.3.b.
- e. *Retrofitting Existing Arterials with Bike Lanes.* The practitioner assesses whether a bike lane can fit on the roadway without any changes to the existing geometry. If not, the engineer then considers various alternatives, including changing the lane widths; assessing the need for on-street parking; evaluating the removal of a travel lane; or, widening the pavement.
- 3 **Signed Bike Route.** Definition (Ref. 8): "a roadway which has been designated by signing as a preferred route for bicycle use." Roadways designated as Signed Bike Routes range from low-volume streets where bike lanes are unnecessary to high-volume streets with narrow travel lanes where bike lanes are infeasible. In any case, a roadway designated as a bike route should offer the bicyclist some advantage compared to alternative streets. At a minimum, the design factors discussed at the beginning of Sec. F1. should be met; other improvements will vary depending on specific conditions. Suggestions are provided below.

a. *Improvements for Signed Bike Routes.*

- (1) Arterials and collectors. If a road with medium to heavy traffic volumes with 4 or more lanes is designated a bike route, then the curb lane should be up to 4.6 m wide (without parking). If there is room for 5 m, consider a bike lane instead. Wide curb lanes are a significant improvement to bicycle safety and comfort. They also provide more room for buses and trucks.
- (2) Local streets. Low-volume streets, including residential streets, with the following features make good bike routes:
  - Few or widely spaced STOP signs to reduce delay (Ref. 27);
  - Low travel speeds (no more than 50 kph);
  - Traffic signal or other help for bicyclists to cross major streets;
  - Traffic calming if needed to inhibit motor vehicles from diverting to this route.
- (3) Shoulders as bike routes. Roadways with shoulders are also appropriate as bike routes, particularly in rural areas where frontage is not developed or on any road where intersections and driveways are widely spaced and right-turn volumes are low.

Roads with medium to heavy traffic volume ideally would have shoulders that are at least 1.2 m wide. The AASHTO *Green Book* (Ref. 28) describes the many benefits of providing shoulders, from improved drainage to longer roadway life.

Rumble strips on shoulders are countermeasures for locations where there are significant run-off-the-road accidents. Caltrans' Recommended Rumble Strip Design (Ref. 29) specifies 1.5 m of clear space to the right of rumble strips so that bicyclists are not negatively affected by the effort to reduce motor vehicle accidents. See California Standard Plans A40a for details.

- b. *Destination Signing.* While signing a road as a bike route theoretically means that this particular road is better than parallel streets, it is much more beneficial to the user if destination signs are provided as well. The supplementary plaque *MUTCD* D-1 series and M-7 series are used to provide destination, distance, and direction information on bike routes. California has approved a variation of the *MUTCD* M1-8 numbered bike route sign, which permits a unique city logo to be used on the top of the sign (Ref. 24 SG-45).

**4 Freeway Use by Bicycles.** Bicycles are permitted on freeway shoulders in many states. In California, a freeway can be opened for bicycle use when the alternate route is unsuitable, and the freeway is suitable (Caltrans *HDM* 1003.4, and see below). The alternate route may be deemed unsuitable because of:

- travel time; if circuitousness is greater on the non-freeway route;
- grades; the non-freeway route may be hillier or more mountainous;
- shoulder widths; the non-freeway route has narrow or no shoulders;
- Intersections; alternate route has excessive number of intersections.

The freeway route is suitable if:

- its shoulders are 2.5 m or wider;
- bicycle hazards, such as drainage grates or expansion joints on shoulders have been eliminated;
- the number, location, and design of entrance and exit ramps do not present hazards;
- traffic volumes on entrance and exit ramps are low.

## 5 Intersection Control.

### a. *Traffic Signals*

(1) **Signal Timing.** Three signal timing parameters affect bicyclists: minimum green times, clearance intervals, and progression. Minimum green timing is important because bicyclists move more slowly, are more easily hidden from view, and are more vulnerable to injury than motorists. Inadequate green and clearance times for bicycles typically occur on a minor street phase, which carries infrequent traffic, or an intersection with a wide major street that carries heavier traffic. Generally eight seconds for the initial green time is sufficient. A more thorough discussion of calculating minimum green and clearance times is presented in Ref. 30.

(2) **Detection.** Type D detectors (Standard Plan ES5D), which are typically used in new construction (see Chap.15) can be easily tuned to detect bicycles. For older installations, priority should be given to the side streets because a bicyclist on a major street with main street recall will get the green light automatically.

The loop detector pavement marking logo shown on Standard Plan A24C may be used to show a bicyclist where to stop in a traffic lane to best be detected. It is placed in the center of the Type D loop. The *MUTCD* R10-22 sign also may be used to supplement the marking.

(3) **Visibility of signal heads** must be checked from the bicyclist's point of view.

b. **Roundabouts.** The benefits for bicycles of roundabouts versus STOP signs are that bicyclists do not have to come to a complete stop, thus they can retain their momentum and reduce their travel time. The benefit over traffic signals is that there is usually less delay than at a signalized intersection, and other traffic travels through the intersection at slower speeds. A bike lane cannot be striped throughout the roundabout; bike lanes must be terminated in advance of the roundabout and then can resume on the other side (Ref. 31). See also Ref. 24, Fig. 25.

c. **STOP Signs.** Although they apply to bicyclists as they do to motorists, as discussed in Ref. 27, STOP signs significantly increase bicyclists' travel time and their fatigue. Two issues regarding STOP signs, particularly on designated bikeways, should be addressed:

- The warrants for the STOP sign should be followed (see Chap. 19).
- Where a two-way STOP sign controls bicycles approaching a medium-to-high volume major street, the bicyclist must await an adequate gap in order to cross, as discussed in Chap. 4 D3. If acceptable gaps do not occur with sufficient frequency, then options to aid the crossing, such as a median or traffic signal, should be considered, especially if the road is a designated bike facility. The *Highway Capacity Manual* (Ref. 32, page 19-7) also discusses the issue of critical gaps for bicycles.



- 6 Level of Service - Quality of Service.** Although there are locations in some communities, such as college towns, and intersections near large high schools or junior high schools, where hundreds of bicyclists will ride in a bike lane or traverse an intersection in an hour, level of service (LOS) in the traditional sense of capacity is not an issue for most bike lanes.

However, even if a bike lane is not near capacity, it may be useful to compare an existing facility to a planned one or to assess the impacts of proposed signal timing on bicycle travel. *HCM* (Ref. 35) Chap. 19 describes the methodology for determining the (LOS) for bike lanes for four conditions:

- *uninterrupted flow* (i.e. segment) - based on the number of passing events;
- *signalized intersection* - based on seconds of delay calculated from a saturation flow and g/c ratio, similar to motor vehicle LOS;
- *sign controlled intersection* - based on seconds of delay using the critical gap methodology; and
- *urban street* - based on the calculated average speed.

The limitations of these methodologies are that the bike lane width as well as other factors such as motor vehicle volumes, motor vehicle speeds, number of driveways, on-street parking, and grades cannot be included as variables due to insufficient research on their effects. However, the uninterrupted flow methodology allows the practitioner to select a range of travel speeds and a range of standard deviations to approximate the side friction caused by these conditions.

For roadways with no bike lanes, several methodologies have been developed to quantify a "stress level," "comfort level of service," or "quality of service" rating system that takes into account lane width, vehicle travel speed, ADT, and other factors. The Florida State DOT has published a *Quality/Level Of Service Handbook* that quantifies the bicycle "quality" of service on roadways without bike lanes (Ref. 33). FHWA is researching the development of an intermodal level of service which may eventually replace Chap. 15 of the *HCM*.

## G. Bike Paths

- 1 Description and Terminology.** The *HDM* (Ref. 8) uses the term Class 1 Bikeway and Bike Path to describe a bikeway that "provides a completely separated right of way for the exclusive use of bicycles and pedestrians with crossflow minimized." Many agencies have found that a well-designed, well-located bike path will attract more than the originally intended users: joggers, roller-bladers, adults with baby strollers, people walking their dogs, non-motorized scooters, and skateboards. AASHTO adopted "Shared Use Path" in 1999, and "trail," "offstreet bikeways," "greenways," "multiuse trail," or combinations of these and other words are also in use. This chapter will use the terms "trail" and "path" interchangeably and assume that multiple users are to be accommodated.

In many cases, experienced bicyclists cannot ride as fast on a bike path as they can on city streets due to either the design of the bike path or the high numbers of slower users. Even in a community with multiple bike paths, bicyclists will still need to use city streets. Thus trails are not to be thought of as replacements, but rather additions to the on-road bikeway network.

Paths can be important components of bikeway networks for transportation, especially when they:

- are long enough and adequately located to provide a car-free environment for a large portion of a bicycling trip; and,
- close gaps in a roadway route, such as connecting two dead-end roads or traversing parks or other places where roads do not go.

The transportation usefulness of a trail can be enhanced by maximizing design speed and minimizing user conflicts and the number of at-grade intersections. Paths make excellent transportation corridors where they have their own right-of-way such as an abandoned—or even active—railroad right-of-way (Ref. 34), utility right-of-way, or area along a creek, canal, river or shoreline. They are not ideal adjacent to roadways, as discussed in Ref. 6, pp. 33–35.

Trails provide a valuable community benefit whether primarily used for transportation or recreation. Design standards must be followed regardless. The practical challenge many agencies face is determining which department is responsible for maintaining trails: public works or parks. This can affect operational elements such as lighting and hours the trail is open.

**2 Design Parameters.** There is no requirement to create a universally accessible trail (Ref. 35). ADA requires only that the issue of accessibility be incorporated into all design, construction, and maintenance activities wherever feasible, given the desired trail experience and the constraints of the natural environment. Design elements will vary depending on the location of the trail, the terrain, the anticipated number of users, and the available right-of-way. The following discussion assumes there are no historical, environmental, topographical or right-of-way constraints.

- a. *Surface.* Trails are commonly paved with either portland cement concrete or asphalt concrete and conform to the grades specified in Ref. 35. However, the trail context will influence these parameters. In a few cases, historical, environmental, or other considerations will require, for example, specification of a softer or more permeable surface. More often, topography may dictate grades that exceed the maximum recommended. Also, not all trail users prefer a hard surface, e.g., joggers and equestrians.

Concrete makes an excellent trail surface when the joints are sawcut; these joints should be spaced at twice the pavement width. Asphalt may also be used; the structural pavement section will depend on the extent to which the trail is also used by maintenance and patrol vehicles. Concrete has lower overall maintenance costs, particularly in freeze-thaw conditions, but higher initial costs.

- b. *Design Speed:* 32 kph minimum on flat grade; up to 55 kph with a sustained grade of at least 3%.
- c. *Geometric Design.*
  - (1) *Width:* A minimum paved width of 3 m is recommended by the AASHTO guide. Where heavy volumes of both bikes and pedestrians are expected, it is advisable to separate slower from faster users; otherwise the trail will be of limited usefulness to cyclists who ride over 15 kph. This is best handled by design rather than signs or striping, since enforcement will be difficult. Consider two parallel trails when pedestrian volumes are heavy, or a 1.5-m wide soft graded shoulder for use by joggers and pedestrians.
  - (2) *Shoulders:* Width should be 0.6 m minimum on both sides, although 0.9 m is preferable; up to 1.5 m if the shoulder is to be used as an optional soft trail for joggers and others. Slope should be a minimum of 2%; maximum 16%; if used as secondary trail, no greater than 5%.
  - (3) *Grade:* The trail should conform to natural topography with 5% maximum preferred. Grades should adhere to ADA pedestrian limits (Chap. 20, part E.1).
  - (4) *Curvature.* Refs. 6 and 8 both contain guidance for designing horizontal and vertical curvature based on design speeds and sight distance. As a rule of thumb, a minimum horizontal radius of curvature of 15 m should be provided, signed with a standard curve warning sign for 15 kph. Artificial horizontal curvatures should not be designed, as these unnecessarily reduce travel speed and increase the overall distance traveled. They also could result in new trailblazing along the shortest path between two points.

- d. *Signs.* Signs used on trails have the same shape, legend, and color as those on roadways. They may be smaller as specified in *MUTCD* Table 9B-1. It is important that they be retro-reflectorized. Placement should conform to the following standards:

Lateral clearance: 0.9 m minimum, 1.8 m maximum from near edge of sign to nearest edge of path.

Mounting height: 1.2 m minimum, 1.5 m maximum from nearest edge of path.

Vertical clearance for overhead signs is 2.4 m minimum.

Common road signs used on trails are curve warning signs, STOP, and Yield signs. Signs unique to trails may be used to direct pedestrians and bicyclists, such as "Bikes Left - Peds Right" *MUTCD* R9-7.

- e. *Markings.* Pavement markings on trails also follow highway standards. The typical letter height is 1.2 m. For recommended marking materials to increase skid resistance, see discussion under Bike Lane markings in Sec. F 2 of this chapter.

Natural and man-made obstructions within the path or graded shoulder should be marked with retro-reflective material (Refs. 6 and 17a).

- 3 **At-Grade Intersection Design.** The at-grade intersection of a trail and roadway should contain the same elements as any intersection, e.g.: lighting, street and trail name signs, signage and markings appropriate to the right-of-way assignment (see Sec. G4), and trimmed vegetation within the sight distance triangle.

- a. *Curb Ramps.* The trail intersection needs properly designed curb ramps. The ramps should align with the trail; the width of the ramp should match the width of the trail; the slope of the ramps should conform to ADA (1:12 slope max.), and the lip of the ramps should be a maximum of 6 mm.
- b. *Bollards:* Bollards and fences have been used to prevent motorized vehicles from entering bike paths and to slow bicycles approaching the intersecting street. Bollards should be used only as a last resort to keep motor vehicles from using the trail. A bollard designed to keep out motorcycles will also restrict bicycles and should not be used. Badly designed bollards are obstructions to the trail user.

Alternatives to bollards for warning a bicyclist on a path are appropriate signage and pavement markings as well as clear sight distance. In special cases, horizontal or vertical curves may be incorporated into the trail design to slow bikes approaching an intersection, with appropriate warning signs.

- 4 **Overcrossings and Undercrossings.** Crossings of major barriers such as freeways, rail lines, and waterways are needed to fully implement the trail network. Some of these will be easier to implement than others due to the geometry of the structure to be crossed.

Tunnels require less up and down cycling than do bridges since the vertical clearance of a bike path is 2.5 m minimum, while an overcrossing must meet the specifications of the road or rail right-of-way to be crossed and could be as high as 7 m in the case of a railroad. Clear sight distance through the tunnel and lighting are key if tunnels are to work well.

- 5 **Intersection control.** The intersection control device depends on the total and relative volumes on the roadway and on the trail.

- a. *Trail Intersecting another Trail.* The best method for controlling the intersection of two trails is a roundabout or small traffic circle. This design essentially channelizes the entering bicycles into a uniform predictable flow through the intersection. The number of conflict points is dramatically reduced, as are the misjudgments about gap size and who got there first. Roundabouts have been successfully used at trail intersections.
- b. *Trail Intersecting a Driveway, Private, or Low Volume Road.* If sight distance is adequate, a YIELD control can be appropriate for this type of intersection. If sight distance is not adequate, a STOP sign should be installed. If the trail volume is higher than the cross-traffic, the trail is given the right-of-way.

- c. *Trail Intersecting a Moderate-Volume Roadway.* Where a trail intersects a moderate-volume street, the right-of-way usually goes to the street. However, if the trail has the higher volumes, consider assigning right-of-way to the trail as if it were the intersection of two roads. If sight distance is adequate, a YIELD sign can be used in lieu of a STOP sign as described in the *MUTCD* and the *California Supplement*. As the volume on the roadway increases, and, becomes more difficult to cross, consider a median refuge or in-pavement flashing lights.
- d. *Trail Intersecting an Arterial.* The pedestrian signal warrants in the *MUCTD* may be used to assess the need for a signal. All trail users are included in the pedestrian volume.

An overcrossing or undercrossing of the arterial should be considered if trail volumes and arterial volumes are high enough that trail users benefit from the reduced delay, and progression would be maintained on the arterial.

- 6 **Level of Service/Quality of Service.** See also F.6. above. The *HCM* (Ref. 32) presents the methodology for determining the level of service (LOS) for both exclusive bike paths and multiuse trails based on the hindrance encountered from meeting and passing events. A significant proportion of pedestrians on the trail may adversely affect the bicycle LOS because of the speed difference. The bicycle level of service is calculated for each direction of traffic unless the directional split of both bikes and pedestrians is 50:50. The needed data to calculate the LOS are bicycle and pedestrian flow rate by direction, mean speed of the bike, and the mean speed of the pedestrians. The methodology assumes that the speeds are normally distributed. The number of events is then calculated and converted to a LOS using Table 19-1 of the *HCM*.

## H. Bike Parking

The lack of a secure parking space keeps many people from using their bikes for basic transportation. Leaving a bicycle unattended, even for short periods, can easily result in damage or theft. If there are no bike racks, or if they are inconveniently located, those who do choose to cycle will use whatever is available, from fences to trees to hand rails, to secure their bikes.

### 1 Definition of Types of Bicycle Parking

- a. *Class I Bike Parking* protects the entire bicycle and its components from theft, vandalism, and inclement weather. It is appropriate for long-term bicycle parking such as at employment centers or transit stations. The most common example is the bike locker, which is typically reserved in advance by a single person. While very popular with regular commuters, the main drawback is that a bike locker is not available to the occasional bike commuter or to one who does not want to go through the paperwork involved in obtaining a key. Other disadvantages are that a fee is usually charged, and the locker can only be used by one person. One promising solution is "on-demand" lockers, where an electronically coded card can be used to open any available locker.

Variations on Class I parking that are effective at larger employment sites and schools are rooms with key access for regular bike commuters, guarded or fenced bike parking areas, such as, at elementary schools when arrival and departure times are consistent, and valet or check-in parking at outdoor events and fairs. A variation on valet parking is a bike station, which provides attended bike parking in an enclosed interior space, usually at a major transit hub (e.g., at rail stations in Los Angeles, Berkeley, and Palo Alto, CA)

- b. *Class II Bike Parking* is a bike rack to which the frame and at least one wheel can be secured by a user-provided U-lock or lock and cable. Class II parking is appropriate at shopping areas, libraries, and other places where the typical parking duration is less than two hours. Racks that secure only one wheel and to which the frame cannot be secured with a U lock or short cable are never recommended.

- 2 **Design of an Effective Bike Rack.** Bike racks meeting the definition of Class II are the inverted U-rack, horse rail rack, and the wave or ribbon rack. Schedule 40 pipe with a 50 mm diameter is recommended; stainless steel and brass are also acceptable. It may be coated with materials to improve aesthetics and match local decor as long as it resists rusting and corrosion. Racks should be of minimum height so as to increase visibility to pedestrians. Incorrect placement of racks can render them useless; therefore adherence to placement guidelines (see below) is essential. The Association of Pedestrian and Bicycle Professionals (APBP) has published a bike parking guide (Ref. 36) that provides a thorough discussion of what makes a good bike rack and how the racks can be combined to form an effective unit.
- 3 **Bike Rack Placement.** To be effective, bicycle racks and lockers must be placed so that security is maximized, pedestrian circulation is not adversely affected, the racks can be used to their maximum design capacity, and the bicyclists can find them. See Ref. 24, Figs. P1 – P4, for detailed placement guidelines. Some of the considerations for the placement of bike racks are:
- at least a 0.6 m clearance from the building, fence, curb, or other obstruction to the outside edge of a bike rack to be able to properly lock a bike to the rack;
  - no farther than 15 m from the building entrance and clearly visible from the building entrance and its approaches;
  - outside the typical pedestrian travel path, with additional room for bicyclists to maneuver outside the pedestrian way;
  - a sufficient distance from motor vehicles to prevent damage to parked bicycles and motor vehicles;
  - not hidden by landscaping, fences, or other obstructions;
  - lit at night to protect both the bicycle and the user;
  - visibility from the racks to at least one of the following: security guard, station agent, parking garage attendant, vendor, or passing pedestrians;
  - protection from the weather for a portion of the rack supply;
  - an all-weather, drainable surface (e.g., asphalt, concrete); care in using brick or other materials that can become slippery when wet;
  - signage to direct bicyclists to bicycle racks that may not be readily apparent, e.g., in parking garages.
- 4 **Bike Rack Quantity.** Recommendations for bicycle parking supply are shown in Table 21-9. Optimally, a mix of both Class I and Class II parking should be provided at virtually all employment sites. The quantities in Table 21-9 are for communities with bicycle commute rates of less than 2%. The recommended amount of bicycle parking should be increased proportionately for those cities or communities whose bicycle commuting exceeds this rate. Many cities have a variation of this table in their development ordinances. A summary of 145 U.S. cities' bike parking ordinances is located on the Massachusetts Bicycle Coalition's website (Ref. 38).

**TABLE 21-9–Bicycle Parking Requirement Recommendations<sup>1,2</sup>**

Residential (e.g., apartments & townhouses)	
General, multi-dwelling	1 Class I/3 units + 1 Class II/15 units
Primarily for students & low-income families, multi-dwelling	1 Class I/2 units + 1 Class II/15 units
Primarily for residents 62 and older, multi-dwelling	1 Class I/30 units + 1 Class II/30 units
Schools	
Elementary, middle & high schools	1 Class I/30 employees <sup>(3)</sup> + 1 spot/12 students (50% Class I and 50% Class II)
Colleges – student residences	1 Class I/4.5 beds + 1 Class I/30 employees
Academic buildings and other university facilities	1 Class I/30 employees + 1 spot/9 student seats (25% Class I + 75% Class II)
<b>Park-and-ride lots/parking garages</b>	7% of auto parking (75% Class I + 25% Class II)
<b>Transit centers</b>	5% of daily boardings (75% Class I + 25% Class II)
<b>Cultural/recreational</b> (incl. libraries, theaters, museums, & religious institutions)	1 Class I/30 employees + 1 Class II per 140 m <sup>2</sup> or 1 Class II/60 seats, whichever is greater
<b>Parks/recreational fields</b>	1 Class I/30 employees + 1 Class II/9 users during peak daylight times of peak season
<b>Retail sales/shopping center/ financial Institutions/supermarkets</b>	1 Class I/30 employees + 1 Class II/560 m <sup>2</sup>
<b>Office buildings/offices</b>	1/6000 sq. ft. (75% Class I & 25% Class II)
<b>Hotels/motels/bed-&amp;breakfasts</b>	1 Class I/30 rooms + 1 Class I/30 employees
<b>Hospitals</b>	1 Class I/30 employees + 1 Class II/45 beds
<b>Restaurants</b>	1 Class I/30 employees + 1 Class II/280 m <sup>2</sup>
<b>Industrial</b>	1 Class I/30 employees or 1 Class I/140 m <sup>2</sup> . (whichever is greater) + 1 Class II/1400 m <sup>2</sup>
<b>Day care facilities</b>	1 Class I/30 employees + 1 Class II/75 children
<b>Auto-oriented services</b>	1 Class I/30 employees
<b>Other uses</b>	Same as most similar use listed

NOTES: 1 - For cities with less than 2% bicycle commuter rate. Pro-rate for cities with higher commute rates.

2 - The minimum number of required Class II Bicycle parking spaces is 4, except when the code would require 1 or fewer, in which case 2 bicycle spaces must be provided.

3 - Employees = maximum number of employees on duty at any one time.

Source: Ref. 37

## REFERENCES

1. Hymowitz, C. and M. Weissman. "History of Women in America," Bantam Books, 1981.
2. Transportation Research Board. *Expanding Metropolitan Highways: Implications for Air Quality and Energy Use*. NCHRP Synthesis of Highway Practice 43. Washington, DC: 1977.
3. American Automobile Association, 2005.
4. Roelofs, C. and C. Komanoff, *Subsidies for Traffic: How Taxpayer Dollars Underwrite Driving in New York State, A report for the Tri State Transportation Campaign*, March 1994.
5. Jacobsen, P. *Safety in Numbers: More Walkers and Bicyclists, Safer Walking and Bicycling*, Injury Prevention 2003; 9:p205-209.
6. AASHTO *Guidelines for the Development of Bicycle Facilities*, 1999.
7. Forester, J.. *Bicycle Transportation*, MIT Press, 1994, 320 pp.
8. Caltrans. *Highway Design Manual Chapter 1000- Bikeway Planning and Design*, available at: [www.dot.ca.gov/hq/oppd/hdm](http://www.dot.ca.gov/hq/oppd/hdm).

9. Bay Area Travel Survey, Table 2.4.2, Metropolitan Transportation Commission, 2000. Available at [www.mtc.ca.gov/maps\\_and\\_data/datamart/survey](http://www.mtc.ca.gov/maps_and_data/datamart/survey).
10. U.S., DOT. *National Household Travel Survey 2001*.
11. *Injury to Pedestrians and Bicyclists: An Analysis based on Hospital Emergency Department Data*, U.S. DOT, FHWA Report No. FHWA-RD-99-078. Available at: [http://safety.fhwa.dot.gov/ped\\_bike/bike/bike\\_crash.htm](http://safety.fhwa.dot.gov/ped_bike/bike/bike_crash.htm).
12. Aultman-Hall, L. et al. *Sidewalk Bicycle Safety Issues and Research Design: Insights from a Survey of Urban Bicycle Commuters*, Transportation Research Record 1636, 1998.
13. Moritz, W. "Adult Bicyclists in the United States - Characteristics and Riding Experience in 1996," Transportation Research Record 1636, 1998.
14. Cross, K., and G. Fisher, *A Study of Bicycle/Motor Vehicle Accidents: Identification of Problem Types and Counter Measure Approaches*, NHTSA, 1976.
15. Hunter, W., J. Stutts, W. Pein, and C. Cox. *Pedestrian and Bicycle Crash Types of the Early 1990s*, Table 41, FHWA-RD-9-163, June 1996.
16. California. *Vehicle Code*. Issued annually. Abbreviated as "CVC."
17. a. U.S. FHWA. *Manual on Uniform Traffic Control Devices for Streets and Highways 2003, Rev 1*. Washington, DC: 2004. <http://mutcd.fhwa.dot.gov/pdfs/2003r1/pdf-index.htm>.  
 b. U.S. FHWA. *Standard Highway Signs*, 2004 Edition, Metric and English Versions.  
 c. California Dept. of Transportation. *California Supplement to the MUTCD, Part 9: Traffic Controls for Bicycle Facilities*. [www.dot.ca.gov/hq/traffops/signtech/mutcdsupp/index.htm](http://www.dot.ca.gov/hq/traffops/signtech/mutcdsupp/index.htm).
18. Schimek, P., Ph.D. A Guide to Improving U.S. Traffic Laws Pertaining to Bicycling, 2002 <http://bicycledriving.com/trafficlaw.htm>.
19. English, J., *Liability Aspects of Bikeway Designation*, April 1986 Bicycle Federation of America.
20. Tardiff, M.E., Torts Division, Washington State Attorney General, presentation at TRB Bicycle Committee, January 13, 2004.
21. DeRobertis, M., and K. St. Jacques, *Innovative Signing and Striping for Bike Facilities*, Compendium of Technical Papers, 65th ITE Annual Meeting, 1995, available at [www.uctc.net/cp290](http://www.uctc.net/cp290).
22. California. *Streets and Highways Code*. Issued annually. Abbreviated as CSHC.
23. Cambridge Systematics, Inc., Bicycle Federation of America, and M. Replogle. *Guidebook on Methods to Estimate Travel*. Federal Highway Administration, Washington, DC, July 1999. [www.safety.fhwa.dot.gov/fourthlevel/pdf/guidebook1.pdf](http://www.safety.fhwa.dot.gov/fourthlevel/pdf/guidebook1.pdf).
24. Valley Transportation Authority. Bicycle Technical Guidelines. [www.vta.org/news/vta/cmp/bikes](http://www.vta.org/news/vta/cmp/bikes).
25. U. S. FHWA. *Bicycle Safety-Related Research Synthesis*. (FHWA-RD-94-062 April 1995). It also found studies from other countries that documented benefits of bike lanes.
26. Harkey, D. and J. R. Stewart, UNC HSRC. *Evaluation of Shared-Use Facilities for Bicycles and Motor Vehicles* TRB 1997. 27. Fajans, J., and M. Curry. *Why Bicyclists Hate Stop Signs*, ACCESS, No. 18, Spring 2001, University of California Transportation Center.
27. Fajans, J., and M. Curry. *Why Bicyclists Hate Stop Signs*, ACCESS, No. 18, Spring 2001, University of California Transportation Center.
28. AASHTO. *A Policy on the Geometric Design of Highways*, Chapter 4, 2004.
29. Traffic Operations Program, Caltrans, *Evaluation of Milled-In Rumble Strips, Rolled-In Rumble Strips and Audible Edge Stripe* FINAL REPORT May 2001.

30. Wachtel, A., J. Forester, and D. Pelz. *Signal Clearance Timing for Bicyclists*, ITE Journal, Sept. 1995.
31. Kittelson & Associates, Inc, et al. *Roundabouts: An Informational Guide*, FHWA, Report No. FHWA-RD-00-067, June, 2000.
32. Transportation Research Board. *Highway Capacity Manual 2000*, Washington, DC: 2000.
33. Florida DOT. *Quality/Level Of Service Handbook*, 2002. Available at: [www.dot.state.fl.us/planning/systems.sm/los/default.htm](http://www.dot.state.fl.us/planning/systems.sm/los/default.htm).
34. Kraich, P., *RAILS-WITH-TRAILS Sharing Corridors for Transportation and Recreation*, Rails-to-Trails Conservancy in cooperation with the National Park Service. Updated September 1997.
35. Beneficial Designs, Inc. *Designing Sidewalks and Trails for Access. Part II of II: Best Practices Design Guide*. Publication No. FHWA-EP-01-027, September 2001.
36. Association of Pedestrian and Bicycle Professionals (APBP). *Bike Parking Guide*. [www.apbp.org](http://www.apbp.org)
37. League of American Bicyclists, 1994.
38. Data compiled by Paul Schimek, Bicycle Coordinator, City of Boston, April 2002. Available at <http://www.massbike.org/bikelaw/parkcomp1.htm>.





## A. Objectives of Speed Control

- 1 **Regulating Motorists' Speed Choices** (Ref. 1).
  - a. Speeds are controlled to limit the danger that drivers might otherwise impose on road users by driving at unsafe speeds.
  - b. Some motorists, especially those unfamiliar with the area, may be unable to anticipate roadway conditions and to select the appropriate speed. Inexperienced drivers may misjudge the stopping and handling performance of their vehicles at higher speeds.
  - c. Many drivers underestimate the effects of higher speeds on crash probability and severity.
- 2 **Reduction of Accidents and Their Severity.** Speeding, defined by NHTSA as exceeding the posted speed limit or driving too fast for conditions, was a contributing factor in 31% of the fatal crashes in the United States in 2004; nearly 13,200 persons were killed in these crashes (Ref. 2). Intuition, the laws of physics, physical tests, and actual observations confirm the premise that crash severity increases at higher speeds. Evidence relating general crash occurrence and speed is less compelling, although single-vehicle crashes are more common at higher speeds.
- 3 **Increase in Capacity.** Traffic moving at a fairly uniform speed flows more smoothly. The objective is to maximize the proportion of cars in the "pace." (See Chap. 6, Sec. G.4.c)

## B. Basic Speed Rule

The Uniform Vehicle Code (UVC) and most state motor vehicle laws include a basic speed rule with wording similar to the following: "No person shall drive a vehicle at a speed greater than is reasonable and prudent under the conditions, including actual and potential hazards then existing. Consistent with the foregoing, every person shall drive at a safe and appropriate speed when approaching and crossing an intersection or railroad grade crossing, when approaching and going around a curve, when approaching a hill crest, when traveling upon any narrow or winding roadway, and when special hazards exist with respect to pedestrians or other traffic or by reason of weather or highway conditions." (Ref. 3, § 11-801.)

## C. Speed Limits

- 1 **Concepts.**
  - a. *Prima Facie Limit.* A speed limit that, if exceeded, is evidence that the speed is not "reasonable and prudent." However, drivers charged with violating a prima facie limit have the opportunity in court to demonstrate that their speed was safe for conditions at the time. Although they may have exceeded the numerical limit, they argue that they were in compliance with the basic speed law. Three states have prima facie limits on all their roads (Ref. 4).

- b. *Absolute Limit.* A speed limit, the exceeding of which is always in violation of the law, regardless of conditions and hazards involved. Even with absolute limits, citations are rarely issued for speeds 2 to 8 km/h [1 to 5 mph]\* above the limit, in part because judges are reluctant to convict "speeders" for such a minor transgression. Thirty-seven states have absolute speed limits on all of their roads. Eleven states have prima facie limits on some roads and absolute limits on others (Ref. 4).
- c. *Numerical Values.* In the United States, speed limits are posted in 8 km/h [5 mph] increments from 24 to 121 km/h [15 to 75 mph]. In countries using metric measurements, speed limits are generally multiples of 10 km/h.

## 2 Statutory Speed Limits.

State motor vehicle laws specify numerical values for maximum speeds on certain types of roadways, in specified areas, for selected vehicle types, and under adverse environmental conditions. Some states specify minimum speed limits, typically for freeways. Agencies responsible for streets and highways have the authority to post speed limits greater or less than the statutory limits on specific roadway segments based on an engineering study (see Sec. D).

- a. *Statewide Limits* (Ref. 1). In 2006, maximum Interstate highway speed limits in rural areas ranged from 105 km/h [65 mph] in some states to 121 km/h [75 mph] in others for passenger cars. Limits in urban areas, and limits for trucks in all areas, were as low as 88 km/h [55 mph] in many states. Maximum limits on highways without access control were generally 88 or 105 km/h [55 or 65 mph].
- b. *Types of Roadways and Areas.* Statutory speed limits are normally established for specific areas or roadway types. The UVC (Ref. 2) recommends maximum limits of 48 km/h [30 mph] in urban districts and 88 km/h [55 mph] in other locations (Ref. 3, §11-802). The UVC also provides for speed zoning on state roads and local streets (Ref.3, §11-803 and 11-804). Most state motor vehicle laws provide more detail; see Ref. 4 for limits in each state. California limits include (see link from Ref. 4)
  - 113 km/h [70 mph] after an engineering and traffic study and consultation with the California Highway Patrol
  - 105 km/h [65 mph], except as provided
  - 88 km/h [55 mph] on two-lane undivided highway
  - 40 km/h [25 mph] in a business or residence district
  - 40 km/h [25 mph] near a facility used by senior citizens
  - 24 km/h [15 mph] on any alley, or approaching uncontrolled intersections or rail-highway grade crossings with limited sight distance.
- c. *School Zones.* Virtually all states have enacted special speed restrictions for areas where school children cross the road. These limits, which are typically 24 to 32 km/h [15 to 20 mph], apply when special signs with flashers are activated or "when children are present." See also Chap. 20, Part F.
- d. *Heavy Vehicles.* From any initial speed, heavier vehicles require a longer distance than passenger vehicles to decelerate to a stop. These vehicles transport cargo that may be more dangerous (flammable, caustic) or, in the case of school buses, vulnerable (young children), so some states have chosen to specify lower speed limits for these vehicles. The so-called differential speed limits for heavy trucks are 8 to 24 km/h [5 to 15 mph] below those for passenger vehicles. At the present time, 11 states have statutory speed limits for heavy trucks over 11,800 kg [26,000 lb] on Interstate highways that are below the limits for passenger vehicles.
  - (1) *Advantages.* If trucks travel at lower speeds than passenger vehicles, their stopping distance differential is reduced. Measured braking distances for single unit trucks and tractor-trailers confirm that these vehicles require longer stopping distances than passenger vehicles (Ref. 5). Empty trucks have greater braking distances than loaded trucks; the poorest braking performance is exhibited by bobtail tractors (the tractor alone, without any trailer). For sight distance limitations created by vertical alignment,

---

\*Because state laws specify speed limits in miles per hour, these values are shown in brackets. Metric equivalents have been rounded to the nearest integer value.

however, the greater height of the truck driver's eye partially corrects for the longer stopping sight distance.

- (2) **Disadvantage.** An enforced differential speed limit increases speed variance and vehicle conflicts due to overtaking, which adversely affects safety. Without enforcement, the actual speed differential is much less than what is posted.
- e. *Environmental Conditions.* Prior to the imposition of the National Maximum Speed Limit (NMSL) of 88 km/h [55 mph] in 1974, motor vehicle laws in some states had lower speed limits during the hours of darkness. The basis for these limits was that vehicle headlights do not provide adequate visibility at speeds above 80 to 88 km/h [50 to 55 mph] at night; the NMSL effectively eliminated this concern. Ref. 1 lists only Texas as still having different nighttime speed limits generally, and Montana with lower night speed limits on non-Interstate highways. In the absence of differential speed limits, actual speeds are 0 to 5 km/h [0 to 3 mph] slower at night than during the daytime (Ref.6).
- f. *Minimum Speed Limits.* The motor vehicle laws of most states provide that motorists may not drive so slowly as to impede the normal and reasonable flow of traffic. Such behavior presents a special problem on high-speed roads. About one-third of the states have enacted minimum speed limits for freeways or Interstate Highways; these are generally 64 km/h [40 mph].
- g. *Federal Speed Limits.* With two exceptions, the establishment of speed limits has traditionally been the responsibility of state and local highway agencies.
  - (1) In 1942, the federal government specified a 64 km/h [40 mph] speed limit (later reduced to 56 km/h [35 mph]) in an effort to conserve resources needed for the war effort.
  - (2) The 1974 NMSL of 88 km/h [55 mph] required each state to incorporate this limit into its motor vehicle laws and provide annual documentation showing substantial motorist compliance. Due to lower speeds and reduced travel, highway fatalities dropped by nearly 9,000 from 1973 to 1974 (Ref. 7; see also Fig. 9-1). Compliance with the NMSL deteriorated as gasoline became more readily available at reasonable prices. Federal legislation in 1987 permitted states to raise speed limits to 105 km/h [65 mph] on rural segments of their Interstate highways. In 1995, Congress returned authority to the states to establish speed limits on their roads. Almost all states took this opportunity to increase their speed limits, primarily on rural highways.

## D. Speed Zoning

- 1 **General.** Speed zoning is the establishment of reasonable speed limits for those highway sections where statutory speed limits would be inappropriate. Zones are based on average traffic conditions and favorable weather; drivers have the responsibility to adjust their speed in adverse conditions.
- 2 **Engineering and Traffic Survey.** According to state vehicle codes, a systematic survey of physical and traffic conditions on the highway section is required before a speed zone is established. The following items should be considered in the survey:
  - a. *Spot Speed Distribution.* The behavior of traffic provides one indication of the appropriate speed limit on a highway section. This study is performed as described in Chap. 6.
  - b. *Standard Deviation of the Speed Distribution.* The dispersion or spread of its speeds (see Chap. 6, Sec. G) is a good indicator of the efficiency and safety of a traffic stream. Locations with broad speed distributions are, therefore, candidates for speed zoning. The standard deviation of the speed distribution should decrease after a speed zone has been implemented.
  - c. *Accident Experience.* Crash patterns on a road segment may indicate the need for a lower or higher speed limit. (A higher limit may result in a more uniform traffic flow, increasing some speeds at the low end of the distribution and reducing the speed of some fast drivers because of the more reasonable limit.) Accident types susceptible to reduction by

better speed control include rear-end collisions and accidents involving overtaking maneuvers. Excessive speed is often cited as a contributing factor to single-vehicle run-off-the-road crashes.

- d. *Roadway and Roadside Features.* Speed zones may enhance safety on substandard sections of generally high-speed roads that contain deficiencies such as:
- (1) Sharp curves or lengthy downgrades
  - (2) Restricted sight distances or view obstructions
  - (3) Poor surface conditions, including broken pavement and drainage dips
  - (4) Narrow roadways or bridges
  - (5) Driveways, parking, and roadside obstacles.

For isolated hazards, warning signs with advisory speed plates are preferred to speed zones.

- e. *Traffic Volumes.* At higher volumes it is especially important that the speed distribution's spread be as low as possible, both for capacity and safety reasons.
- f. *Existing Traffic Controls.* Current speed patterns may, in part, be related to the types of traffic controls in place, inadequately maintained, or missing.
- g. *Pedestrians and Bicycles.* Urban street speed limits exist partly to reduce pedestrian and bicycle crashes. Streets may be zoned for higher speeds if these vulnerable road users are present only infrequently. In rural and suburban areas without traffic signals, speed zones may be needed to provide adequate stopping distance for motorists after they detect pedestrians crossing the road at crosswalks (Eq. [3.7] in Chap. 3).
- h. *Enforcement.* High speeds and/or high speed distribution standard deviations may be caused by a lack of speed law enforcement. A thorough speed zoning study should solicit input from the proper enforcement agencies and consider the potential for addressing any identified problems through enforcement actions rather than by engineering or zoning methods.
- 3 **Expert Systems.** Several Australian states have implemented an expert system-based approach to setting speed limits in speed zones (Ref. 8). The process includes those parameters typically considered in the engineering and traffic study methodology, but makes more explicit the factors and the decision rules involved in determining the appropriate speed limit.
- 4 **Selecting a Value for a Speed Zone.** Engineers have traditionally assumed that most drivers are capable of judging the speed at which they can safely travel on a street or highway. Consequently, the 85<sup>th</sup> percentile speed is a first approximation of the speed limit that might be imposed, subject to consideration of the other factors listed earlier. A recent survey of state and local practices found that the 85<sup>th</sup> percentile speed was the predominant factor used to set the speed limit, followed by roadway geometry, crash experience, and roadside development (Ref. 9).
- 5 **Posting of Speed Zones.** Speed limits established by the speed zoning process must be properly recorded in the files of the highway agency or other designated agency. To be enforceable, they must be posted using standard regulatory signs prescribed by the *Manual on Uniform Traffic Control Devices – MUTCD* (Ref. 10). A sign is placed at the beginning of each zone, at intermediate intervals in lengthy zones, and just beyond major intersections on rural highways.
- 6 **Variable Speed Limits.** Under some fluctuating conditions, it may be desirable to change the speed limit on certain sections of highway for fixed or variable periods of time.
- a. *Predictable needs* to change speed limits at certain hours, such as in school zones, can be handled by legislation.
  - b. *Unpredictable needs* to change speed limits arise from sudden occurrences, such as adverse environmental conditions (e.g., fog or icy bridges) or unexpected problems (e.g., accidents downstream). Speed limits are communicated to motorists through variable message signs operated from a central control center or by sensing devices at the site. Records of the displayed speed limit as a function of time must be maintained to permit proper enforcement.

## E. Other Speed Control Methods

- 1 **Funneling of Lanes and Roadways.** Drivers instinctively slow down as the lane width decreases. This principle is used on freeway off-ramps and at entrances to curves where lower speeds are desired. The lane width reduction must be gradual.
- 2 **Coordinated System of Signals.** Interconnected signals can be timed in progression to have all traffic move at or near a desired speed (see Chap. 16, Sec. C). This can be very effective in urban and suburban areas as long as the individual signals are warranted (see Chap. 19, Sec. D).
- 3 **Speed Humps.** (Refs. 11, 12) Speed humps are rounded, raised, transverse areas of asphalt pavement, generally 3.6 m long in the direction of travel and 75–100 mm high, used to reduce vehicle speeds on residential streets. (Much shorter bumps, 150–300 mm long, are often used on private streets and parking lots.) Humps are typically applied where 85<sup>th</sup> percentile speeds exceed 48 km/h [30 mph].
  - a. *Effect on Speeds.* Speed humps decrease operating speeds at and between properly-spaced successive humps. The vehicle speed distribution narrows (e.g., smaller standard deviation), with the greatest effect on higher speeds. The expected average speed with 75-mm high humps is 32–40 km/h [20–25 mph]; for 100-mm humps, it is 24–32 km/h [15–20 mph].
  - b. *Application.* Humps should be used only under the following conditions:
    - (1) The street serves a purely local access function
    - (2) There is no more than one lane per direction
    - (3) The street is not a transit or truck route
    - (4) The location is not near a fire or police station or a hospital
    - (5) The street is not zoned above 40 km/h [25 mph]
    - (6) Prior to installation, the 85<sup>th</sup> percentile speed exceeds 48 km/h [30 km/h].
  - c. *Design and Location of Humps.* There is considerable debate among traffic engineers regarding the proper dimensions for humps; arguments ensue over height differences as small as 6 mm. The interested reader is referred to ITE's web site (Ref. 12) for the most current information on design features.
 

Typical spacing between successive humps is 100–200 m. Ref. 11 suggests formulae for spacing as a function of desirable speed and hump height. As a practical matter, spacing depends on site conditions – alignment, fire hydrants, driveways, and nearby intersections.
  - d. *Signing and Marking.* The *MUTCD* (Ref. 10) includes standard warning signs and markings for use with speed humps.
  - e. *Caution on Using Speed Humps.* Over the past 20 years, some urban traffic engineering agencies have deployed speed humps extensively. In some cases, citizens have raised concerns based on the Americans with Disabilities Act (ADA) requirements and issues of social inequity (diverting traffic through disadvantaged neighborhoods). These issues deserve consideration in planning and installing speed humps.
- 4 **Traffic Calming.** In response to complaints from residents whose neighborhoods have been invaded by high volumes of shortcutting, speeding traffic seeking to avoid delay at nearby arterial intersections, communities have embraced programs of residential traffic management known as traffic calming to discourage shortcutting traffic and reduce vehicular speeds. Ref. 13 is a good link to the numerous traffic calming techniques. Chap. 34 provides more detail on various traffic calming tools and their effectiveness.
- 5 **Speed Control in Work Zones.** See Chap. 26, paragraph D.3.

## F. Speed Enforcement

- 1 **General.** As with all traffic regulations, speed laws must be enforced to be effective. However, it is unfair for traffic engineers to contend that they simply establish speed limits and that enforcement officers have the duty to cite all of the speeders. Ref. 8 provides a good discussion of the respective roles of engineering and enforcement in managing speeds on U.S. streets and highways.

2 **Patrolling.** Enforcement agencies patrol highways in clearly marked police cars or motorcycles as part of their routine duties; unmarked vehicles are permitted in some jurisdictions. The mere presence of marked patrol vehicles temporarily reduces the speeds of the fastest vehicles. The "halo" surrounding a marked stationary or moving police vehicle is less than 30 s.

### 3 **Methods of Detection.**

- a. *Pacing Violators* is a common method, but is wasteful of manpower and can be dangerous when traffic is congested or the violator is traveling at high speed.
- b. *Speed Traps*, where an officer times a vehicle over a measured distance, are very unpopular with motorists. Any speed limit *not* justified by an engineering and traffic survey (see Sec. D.2.) is defined as a speed trap in California (Ref. 14, §40802). Speeding evidence from speed traps is generally not admissible in court.
- c. *Radar and Laser Meters* are commonly used by enforcement officers. Radar-meter evidence obtained in California speed zones is only valid if the zone was justified by an engineering and traffic survey within the past 5 years.

Extensive use of radar detectors hampers enforcement efforts, and these devices are illegal in a few states (Ref. 4) and in all commercial vehicles.

- d. *Aircraft Spotting* is used, but mainly in rural, western states.
- e. *Automated Enforcement* is used in many countries around the world (see Ref. 8). The concept
  - 1) uses established techniques (e.g., radar, laser, loops) to measure a vehicle's speed,
  - 2) selects vehicles that exceed the limit by an established amount (e.g., 16 km/h [10 mph]),
  - 3) identifies the vehicle by photographing the license plate number, and
  - 4) issues a citation to the vehicle owner with a time-dated photograph of the infraction.

This tool is extensively used in European countries, but public concern has limited its adoption in the U.S. Experimental programs have enjoyed mixed reviews.

### REFERENCES

1. Insurance Institute for Highway Safety. *Maximum Posted Speed Limits for Passenger Vehicles*. As of February 2006. Available at: [http://www.iihs.org/laws/state\\_laws/speed\\_limit\\_laws.html](http://www.iihs.org/laws/state_laws/speed_limit_laws.html).
2. U.S. National Highway Traffic Safety Administration. *2004 Annual Assessment*. Available at: <http://www.-nrd.nhtsa.dot.gov/pdf/nrd-30/NCSA/PPT/2004AnnualAssessment.pdf>.
3. National Committee on Uniform Traffic Laws and Ordinances. *Uniform Vehicle Code*. Alexandria, VA: 2000.
4. *State Traffic and Speed Laws*. Available at <http://www.mit.edu/~jfc/laws.html>.
5. Flick, M.A. and R. W. Radlinski. Braking Performance Comparison of a Sample of Light Trucks and Cars. Society of Automotive Engineers Paper 881857. Detroit: 1988.
6. Harkey, D.L., et al. *Assessment of Current Speed Zoning Criteria*. Transportation Research Record 1281, Transportation Research Board. Washington, DC: 1990.
7. Transportation Research Board. *55: A Decade of Experience*. Washington, DC: Special Report 204, 1984.
8. Transportation Research Board. *Managing Speed: Review of Current Practice for Setting and Enforcing Speed Limits*. Washington, DC: Special Report 254, 1998.
9. *Traffic Engineering Council Report Summary: Survey of Speed Zoning Practices*. ITE Journal, May 2001, pp. 54-55.
10. U.S. Federal Highway Administration. *Manual on Uniform Traffic Control Devices for Streets and Highways – 2003, Rev. 1*. Washington, DC: 2004. <http://mutcd.fhwa.dot.gov/pdfs/2003r1/pdf-index.htm>.

11. Institute of Transportation Engineers. *Guidelines for the Design and Application of Speed Humps*. Washington, DC: 1993.
12. Institute of Transportation Engineers. *Traffic Calming for Communities - Speed Hump*. Washington, DC. <http://www.ite.org/traffic/hump.htm>.
13. Institute of Transportation Engineers. *Traffic Calming: State of the Practice*. Washington, DC: US DOT-FHWA. Aug. 1999. Chapter 5 and Appendices A and B.
14. California. Vehicle Code. Annual. Available at <http://www.dmv.ca.gov/pubs/vctop/vc/vc.htm>.





### A. Purpose

To make the best use of the curb lane by:

- 1 Assigning priorities for its use.
- 2 Designing and marking curb parking spaces.
- 3 Establishing time limits for use.
- 4 Enforcing parking prohibitions and time limits.

### B. Priority for Use of Curb Lane

Fig. 12-1, Chap. 12, schematically depicts the conflicting demands made on street space by traffic movement and by access to adjacent land. A third demand is for storage of vehicles when not in use. The assignment of the curb lane to fulfill one or more of these functions depends on the relative importance of each demand.

- 1 **Traffic Movement.** Where the full curb-to-curb width of a street is needed for traffic movement, parking and stopping should be prohibited. The curb lane can still perform a limited access function at driveways, but its efficiency as a moving lane is impaired in proportion to the number of maneuvers into and out of driveways; i.e., the more access maneuvers are accommodated, the less movement capacity is available.
- 2 **Access to Adjacent Land.** The demand for access to adjacent land from the street is met partly by driveways and partly by loading zones (including parking spaces) that permit persons and goods to be transferred between the transportation system and the land. If the curb lane is devoted primarily to this function, the street's ability to handle through movement will be reduced correspondingly.
- 3 **Storage of Vehicles.** This demand is met by permitting parking in the curb lane. The storage capacity will be limited to the extent that loading zones (as distinct from parking spaces) are needed, and driveways are present. Where the demand for vehicle storage is very high and that for movement is very low, the equivalent of two lanes may be assigned to storage (angle parking). Where the needs for movement and loading predominate, vehicle storage may have to be eliminated.
  - a. *Priority for Short-Term Parking.* In areas of high-density land use the demand for curb parking generally exceeds the supply of spaces. To the extent that curb lanes can be assigned to parking at all, they should be allocated to short-term parkers through the use of time limits. This maximizes the number of persons who can be given accessibility to adjacent land and short-time storage of their vehicles (i.e., maximizes turnover). By this method the majority of parkers in the CBDs of most small and medium size cities are accommodated at the curb. See Sec. D.3.

- b. *Priority for Vehicles of Disabled Persons.* Some parking spaces are designated for the vehicles of disabled persons. See Sec. E.3.
- c. *Priority for Carpool and Vanpool Vehicles.* Curb parking spaces may be reserved for their priority use during weekday working hours. See Sec. F.1.
- d. *Priority for Local Residents.* Residential areas adjacent to major traffic generators often suffer from the overflow of parked vehicles associated with such generators. Parking management schemes can be implemented to keep the overflow out of the area. See Sec. F.2.

### C. Curb Parking-Related Accidents

Curb parking causes a considerable number of midblock accidents on urban streets. In a study of 10 U.S. cities (Ref. 1), it was found that 53 percent of midblock accidents were attributable to parking. Table 23-1 gives a breakdown of this information.

**Table 23-1—Percent of Midblock Accidents Related to Curb Parking**

Type of Collision	Street Classification			All Streets
	Major	Collector	Minor	
Moving vehicle & parked vehicle	23	50	59	31
Unparking vehicle & parked vehicle	16	13	6	14
Parking vehicle & parked vehicle	6	5	2	5
Moving vehicle & open door of parked vehicle	3	0	1	2
Moving vehicle & pedestrian because of sight restriction	0	0	3	1
All collision types	48	68	71	53

Source: Ref. 1.

### D. Curb Parking Restrictions

#### 1 Blanket Prohibitions.

- a. Both the Uniform Vehicle Code (UVC, Ref. 2) and the California Vehicle Code (CVC, Ref. 3) prohibit stopping, standing, or parking, except in compliance with traffic laws or to avoid conflict with other traffic, in the following places (among others):
  - (1) On a sidewalk
  - (2) On the roadway side of another vehicle (double parking).
  - (3) Within an intersection
  - (4) In the curb lane
    - (a) in front of driveways
    - (b) on a crosswalk
    - (c) within 4.6 m [15 ft]\* of a fire hydrant
    - (d) within 6.1 m [20 ft] (UVC) or 4.6 m [15 ft] (CVC) of a fire station driveway
    - (e) between a pedestrian safety zone and the adjacent curb
    - (f) where prohibited by regulatory signs or curb markings
    - (g) where a wheelchair ramp has been provided.
  - (5) On a highway bridge or in a tunnel
- b. The UVC prohibits parking within 6.1 m [20 ft] of a crosswalk at an intersection, and within 9.2 m [30 ft] of a STOP sign, YIELD sign, signal, or beacon. The CVC contains no such provisions.
- c. Section 33-401 of the Model Traffic Ordinance prohibits parking under conditions or in a manner that would leave a width of less than 3.0 m [10 ft] available for free movement of vehicular traffic.

\* - Because the UVC and CVC use "conventional" units, these values are shown in brackets.

## 2 Prohibitions for Traffic Movement Purposes.

- a. When traffic volumes exceed the capacity of a street with curb parking, and other remedies are not feasible, parking may have to be eliminated either during peak periods or altogether. Tow-away zones are often used to enforce this restriction (see G.5.).
- b. At approaches to intersections, curb parking may be eliminated to provide room for a turning lane or an extra through lane.

## 3 Establishment of Time Limits.

- a. *Need.* Time limits should be established only after studies show a demand for additional short-term parking in the immediate area, as evidenced by:
  - (1) High turnover and high occupancy in existing time limit zones.
  - (2) Low turnover and high occupancy where no time limits exist.
  - (3) Cruising vehicles awaiting an opportunity to park.
  - (4) Double parking.
- b. *Length.* Time limits are usually selected as follows:
  - (1) 1 hour for the central portion of a business district.
  - (2) 2 hours in areas adjacent to 1-hour zones to accommodate persons who desire to park longer, but are willing to walk further.
  - (3) 10 to 30 minutes near "errand" type establishments, such as banks and post offices, to accommodate demand for such short-term parking.
  - (4) 2 to 5 hours for Residential Parking Permit Programs; see Sec. F.2.
- c. *Enforcement.* There must be sufficient enforcement personnel to provide coverage of all curb spaces zoned with time limits.

## E. Design of Curb Parking Spaces

When preparing plans for curb parking and loading spaces, curb lengths not available because of parking prohibitions are first determined. The remaining space can then be allocated to the various needs for parking and loading, including spaces for the vehicles of disabled persons.

### 1 Need for Marking.

- Stalls should be marked:
- a. Where high turnover is expected.
  - b. Where parking is not parallel to the curb line.
  - c. Where parking meters or space-specific curb pay stations are used.
  - d. Where absence of markings will cause inefficient use of the available space.
  - e. To define spaces reserved for vehicles of the disabled.

### 2 Space Layout.

- Part a. of Fig. 23-1 shows alternate methods of parallel space layout. The maneuver of entering a stall is easier and less time consuming when stalls are "paired" as shown in the second line of the figure. Part b. of Fig. 23-1 shows space layout for common angles used (any angle between about 20° and 90° is possible). The choice between parallel and angle parking should be made primarily on the basis of the following considerations:
- a. Angle parking spaces use more street width, and moving traffic in the adjacent lane shifts toward the left, requiring a wider lane. Ref. 1 determined that the combined width needed for the parking and adjacent lanes is 6.7 m for parallel parking, 7.9 m for 22.5°, 9.1 m for 45°, and 9.4 m for 60° and over. Therefore, parallel parking is preferred over angle parking where the movement of traffic takes priority over the storage of vehicles, and vice versa.
  - b. Angle parking provides more spaces than does parallel parking for the same length of curb.
  - c. Angle parking is potentially more hazardous than parallel parking because of impaired visibility for the unparking driver, especially when the upstream adjacent vehicle is an SUV. However, one study (Ref. 4) found that the higher number of accidents was proportional to the higher number of parking spaces provided.

d. The most critical maneuver for angle parking—leaving the space—is more quickly and easily completed than that for parallel parking—entering the space (see Table 23-2).

- 3 **Parking for the Disabled** (Ref. 5). Parking spaces for vehicles operated by or on behalf of the disabled are designated by standard signs and blue curb markings. These vehicles may also use regular curb parking spaces and are then exempt from time limit regulations and parking meter charges.

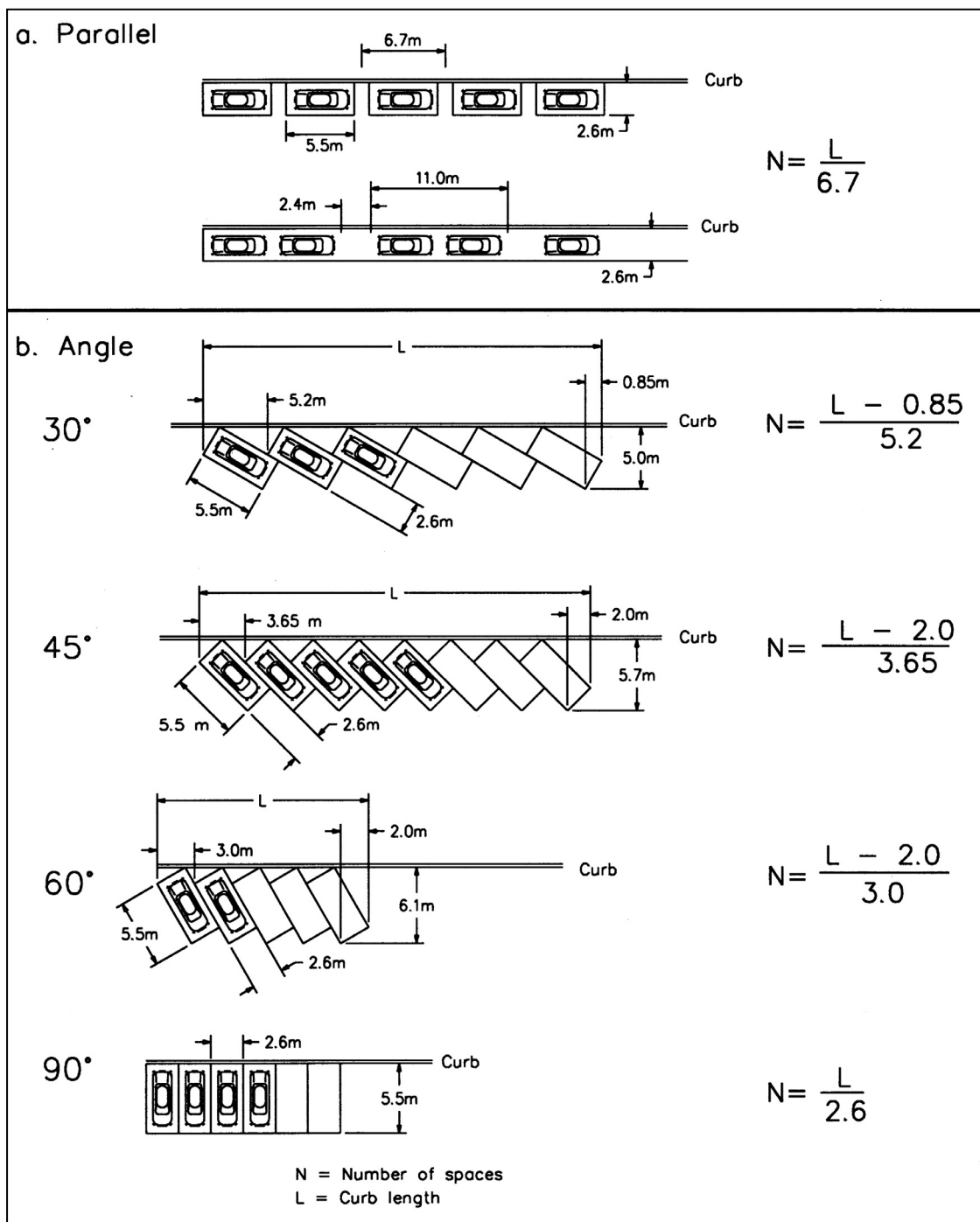

Fig. 23-1—Curb Parking Spaces at Various Angles

**Table 23-2—Curb Parking and Unparking Times**

Maneuver	Time	Parking Angle			
		Parallel	22.5°	40-45°	90°
Head-in parking	Total time	14.7 s	5.8 s	8.9 s	10.4 s
	in traffic*	4.3	3.5	4.8	7.6
Back-in parking	Total time	18.6	-	-	-
	in traffic*	9.3	-	-	-
Unparking	Total time	9.5	8.9	10.6	12.9
	in traffic*	3.5	6.0	5.4	9.7

Source: Ref. 1.

\* - The time that the maneuver interferes with traffic in adjacent lane.

When providing new curb spaces in business and commercial districts, the number of spaces to be designated for the use of vehicles of disabled persons should be the same as for off-street facilities (See Chap. 27, Table 27-2). Spaces must have clearance of 1525 mm to the driving lane and preferably be located near an intersection where wheelchair ramps can be readily used. Angle parking is generally safer for these spaces than parallel parking.

## F. Curb Parking Management Programs

Special curb parking regulations can be promulgated to achieve transportation systems management (TSM) objectives and to solve problems created by excessive demand for curb parking. Two such programs are briefly described here. For a summary of a survey covering various parking management strategies, many applying to curb parking, see Refs. 6 - 8.

**1 Preferential Downtown Curb Parking for Carpool and Vanpool Vehicles.** To promote ridesharing, curb parking spaces in selected areas near business districts may be allocated for priority use by carpool and vanpool vehicles. Two examples are:

- a. *Portland, OR:* Carpoolers purchase monthly permits for \$55, which allow them to park at many of the longer-term downtown metered spaces that are reserved for 3+ person carpools during early morning hours; these spaces become available for normal use later in the day. Carpoolers using these spaces need not feed the meters. The spaces are within walking distance of downtown, but not within the retail and office core. Up to 600 permits are available. Demand for the spaces exceeded supply in 1987, but as of 2005 only 321 permits were being sold. Sixty five permits at \$45 per month were sold to 2-person carpools in the Lloyd District near downtown, and 53 for the Pearl District, part of the downtown program. Permits are transferable between the various vehicles used. (NOTE: Portland supplements these on-street TSM measures with off-street preferential parking for carpools; 475 garage permits are available to pool vehicles; the price varies from \$90 to \$168 per month, depending on location.) (Ref. 9.)
- b. *Seattle, WA:* The City of Seattle provides approximately 300 curb parking spaces and 300 off-street spaces for carpools and vanpools throughout the Central Business District. In early 2005 the subscription rate was about 70%. Each carpool pays \$300 in advance per quarter for one parking permit that may be transferred among its members' vehicles. Registered vanpools may obtain permits for a nominal fee of \$5. Parking spaces are reserved for carpools displaying valid permits between 7 and 10 am weekdays. If a carpool space is vacated by the permit vehicle after 10 am, the space becomes available for parking to the general public. (Ref. 10.)

In both programs, periodic checks are made to assure that the minimum number of occupants are using the vehicles with pool permits. A survey early in the Portland program found that 58% of the respondents were new carpoolers, attracted because of the cost saving; half of these had previously driven alone or with only one other person, the other half had been bus riders.

- 2 **Residential Parking Permit Programs (RPPP).** Where large trip generators create a major parking demand, imposition of time limits in their immediate vicinity has the effect of reserving curb parking spaces for customers, clients, and other short-term visitors. All-day parkers then tend to move to surrounding areas that have not been restricted by parking time limits. Commuters driving to bus stops and transit stations, where insufficient or no off-street parking is available, also look for all-day spaces in nearby neighborhoods. If such areas are residential, the inhabitants must compete for curb parking with commuters' vehicles, and delivery and service vehicles are often forced to double-park. Vehicles hunting for parking spaces also add to the total traffic, noise, and air pollution in the area.

To overcome this problem, time limits of 2 - 5 h can be posted in these residential neighborhoods to place all unrestricted parking spaces beyond acceptable walking distance of the trip generator causing the problem. Without further modification, such time limits will also apply to the neighborhood residents; if ample driveway and other off-street parking exists, this may be a sufficient solution, and the streets will have been cleared of vehicles parked all day and the peak period traffic associated with them. However, in most cases, residents will need the curb parking for their own vehicles, calling for the institution of an RPPP.

An RPPP involves the issue of permits (nontransferable decals affixed to the bumper or windshield of the vehicle) to residents to exempt their vehicles from the posted time limits. A 1996 survey (Ref. 11) found that RPPPs were being used in areas adjacent to educational facilities, CBDs, medical, and recreational facilities. They are also used in large cities near transit stations. RPPPs are usually established in response to neighborhood petitions when curb parking occupancy in the neighborhood reaches some predetermined value. Most apply only on weekdays during the day; some are in effect continuously except Sundays. In some cities or neighborhoods, overnight parking without a permit is prohibited. Permits are either free or nominally priced to cover printing of decals, posting of signs, and the like. Enforcement costs are often more than covered by parking fines generated by the program. Visitors of residents are usually provided for by issue of special permits with limited validity.

Besides achieving the primary objective of removing commuters' cars from residential neighborhoods, RPPPs may also promote a change in mode for these commuters from single-occupant driving to ride-sharing or transit. RPPPs have withstood legal challenges in the U.S. Supreme Court.

## G. Enforcing Curb Parking Regulations

- 1 **Reason for Violations.** Extensive violation of regulations is indicative of one or more of the following conditions:
  - a. The regulations are not reasonable.
  - b. Violators do not understand the importance and value of warranted regulations.
  - c. Regulations are not clearly posted.
  - d. The parking supply deficiency is such that drivers violate regulations out of desperation.
  - e. Regulations are enforced infrequently or not at all.
  - f. Fines for infractions are low in comparison with offstreet parking charges.
- 2 **Methods of Patrol.** Patrolling—usually by parking enforcement personnel—can be performed on foot, by car, by three-wheel motorcycle, or by small utility vehicle. Hand-held computers are sometimes used to record license plates (in lieu of marking tires) to enforce time limits, and to check license plates for stolen vehicles and scofflaws (para. 6. below).
- 3 **Enforcement of Unmetered Parking Time Limits.** Time limits at unmetered spaces are enforced by patrolling at regular intervals and marking tires or recording license plate numbers. To minimize overtime parking, patrols should be scheduled to return to each block face at intervals no more than 30 minutes greater than the time limit being enforced. In some countries "parking disks" are used. The driver sets the time of arrival and places the disk inside the windshield. Enforcement officers can see readily how long the car has been in its present location.

- 4 Enforcement by Parking Meters and Pay Stations.** Parking meters at the curb were introduced to enforce time limits more efficiently than is possible by other means. The resulting revenue was originally a secondary objective, but is now considered an important source of funds for off-street parking financing, traffic control projects, traffic enforcement, and general government budgets.

Parking meters are inexpensive to purchase, install, and—unless plagued by vandalism—maintain in comparison to the revenue that they can produce, provided that they are placed in locations where there is sufficient demand for short-term parking. The annual revenue per meter often exceeds 2,000 times the hourly meter rate, while annual average maintenance and collection costs are likely to be perhaps \$100 per meter. However, repair or replacement costs for worn and vandalized units must also be anticipated. In view of the large amount of revenues involved, extensive security measures to prevent loss of funds are required.

*Multi-space meters (space-specific pay stations)* reduce operating and maintenance costs as well as the amount of clutter along sidewalks. They may cover up to 10 curb spaces. Signs and markings must be provided to direct motorists to the correct meter and to indicate the correct space number.

*Ticket dispensers*, found in off-street parking facilities (see Chap. 27, Sec. J.2.b.), have also begun to be used for curb parking. One machine may cover an entire block, and there is no need to link each payment to a specific space. The expiration time paid for is shown in large type on the receipt, which must be displayed on the dashboard or attached to the driver-side window to be easily visible to the enforcement patrol. A financial advantage of this payment system to the municipality is that motorists do not receive credit for unexpired time of the previous occupant of the parking space.

Modern models of meters and ticket dispensers accept credit card payment.

Tire marking or license plate recording may be necessary to minimize meter feeding and increase parking turnover.

- 5 Towing** (see also para. 6). Towing illegally parked vehicles may be necessary if:
- a. the vehicle blocks a lane assigned to moving traffic and substantially reduces the capacity of the street. This occurs most commonly where a curb parking lane becomes a traffic lane during peak hours. Parking signs must include information about the towaway program.
  - b. the vehicle has been parked longer than the maximum time provided by law (72 hours in California) and may have been abandoned.
- 6 Collection of Unpaid Parking Fines.** One problem with curb parking enforcement is scofflaws, who ignore parking citations. Among methods used to collect unpaid fines are:
- a. *Immobilizing.* If a parking enforcement officer sees a car that is on a scofflaw list, a special crew is called to attach a "Denver Boot" to one of the wheels. The vehicle cannot be moved until the boot is removed—after arrangements for paying the outstanding fines have been made. In California, CVC § 22651.7 permits this procedure if certain conditions are met. Booting does not help where the vehicle blocks traffic, and vehicle towing is necessary. Ref. 11 reports that 26% of responding municipalities boot vehicles of scofflaws and that 37% tow such vehicles.
  - b. *Withholding of Registration Renewal.* Withholding vehicle registration renewal until outstanding fines have been paid is used in many states and some municipalities. However, this method is not effective where out-of-state motorists are involved.

## H. Curb Loading

- 1 Freight.** Commercial establishments that receive or ship merchandise require an area where freight can be unloaded and loaded. In many cities, new buildings are required by ordinance to include off-street loading docks for this purpose. However, many older buildings must handle their deliveries and shipments from the street.



- a. Sufficient curb length should be dedicated to truck loading zones to handle demand. Too many loading zones cause unnecessary loss of curb parking space; too few cause double parking by trucks. Each block must be studied separately. In California, truck loading zones are indicated by yellow curb markings. Ordinances often provide that private vehicles may park there after business hours and on holidays.
- b. Restricting loading and unloading to specific time periods is difficult to implement because of opposition by business owners and trucking firms. These groups would be required to hire employees at unusual hours, often at premium pay. The easiest time restriction to enforce, and the one of the most value to reducing traffic congestion, is prohibition of stopping during morning and evening peak hours.

**2 Buses.**

- a. *Location of Stops.* Curb bus stops may be located either in the approach to intersections ("near side"), in the exit from intersections ("far side"), or midblock. The optimum location depends on the turning movement patterns of buses and of other traffic, pedestrian patterns (including those transferring between routes), and the location of large traffic generators on abutting land.
  - (1) Near-side stops are preferred at locations where transit is more "critical" than automobile traffic and parking, at intersections where more traffic joins the street than turns off it, at intersections with one-way streets moving from right to left, and at locations where buses will make a right turn. Near-side stops have the additional advantage that they can be used by right-turning vehicles when not occupied by buses, thus increasing intersection capacity.
  - (2) Far-side stops are preferred at locations where transit is less "critical" than other traffic or parking, where there is a heavy right and/or left turn movement off the street, at intersections with one-way streets moving from left to right, and where buses make left turns.
  - (3) Midblock stops are recommended where traffic or sight distance problems make stops near the intersection undesirable, or where large traffic generators are located near the midpoint of long blocks. They should not be used where passengers wish to transfer to and from a route on an intersecting street, where parking is critical (midblock stops require more curb length), or where jaywalking would be especially dangerous.
- b. *Length.* Minimum desirable lengths of bus loading zones are given in Table 23-3. Whether a one-bus stop, two-bus stop, or even longer stopping zone is required can be calculated from the estimated service time per bus and average headways. See Ref. 12.

**Table 23-3—Minimum Desirable Lengths for Bus Curb Loading Zones**

Location of Stop	Length of Loading Zone (m)			
	Bus 300 mm from curb		Bus 150 mm from curb	
	One berth	Two berths	One berth	Two berths
Near Side†	L + 20	2L + 21	L + 26	2L + 27
Far Side‡	L + 12	2L + 12	L + 17	2L + 17
Midblock‡	L + 30	2L + 30	L + 41	2L + 41

Source: Based on Ref. 13.

L - Length of longest bus using stop.

† - Add 5 m to length where buses make a right turn, or 9 m where there is also heavy right turn volume of other traffic.

‡ - Based on roadway 12 m wide; add 5 m to length if roadway is only 10 m wide. These dimensions allow bus to leave loading zone without passing over street centerline.

- c. *Marking.* In California, transit stops are indicated by red curb markings and signs. Pavement markings may also be used.

**3 Auto Passengers.** Special passenger loading zones are established at entrances of hotels, auditoriums, transportation terminals, and other generators of heavy auto passenger traffic. Ordinances or laws generally permit parking for 3-5 min, but the primary purpose is to load

or unload passengers. The zones may be in force permanently, where the demand for passenger loading occurs at all hours, or may be in effect only during certain hours, as in front of theaters. In California, passenger loading zones are indicated by white curb markings.

- 4 **Taxis.** Special zones for queues of taxis awaiting passengers at hotels, terminals, and similar locations are generally treated as an extension of the auto passenger loading zone.

#### REFERENCES

1. Humphreys, J.B. et al. *Safety Aspects of Curb Parking*. Washington, DC: U.S. FHWA, Sept. 1978. (Report No. FHWA-RD-79-76.) 194 p.
2. National Committee on Uniform Traffic Laws and Ordinances. *Uniform Vehicle Code and Model Traffic Ordinance*. Evanston, IL: 1992, § 11-1003.
3. California Department of Motor Vehicles. *2005 Vehicle Code*. Sacramento: 2005, § 22500 et al. Available online at <http://www.dmv.ca.gov/pubs/vctop/vc/vc.htm>.
4. McCoy, T. A., et al. "Safety Evaluation of Converting On-Street Parking from Parallel to Angle." *Transportation Research Record 1327*. Washington, DC: 1991. pp. 36-41.
5. Williamson, D.S. and G.S. Marx. *ADA Parking Compliance Manual*. Fredericksburg, VA: Institutional & Municipal Parking Congress, 1993, v.p.
6. DiRenzo, J.F. et al. *Study of Parking Management Tactics*. Volume I: Overview. Washington, DC: U.S. FHWA (Report FHWA-PL-79-020). Dec. 1979, v.p.
7. Public Technology, Inc. *Innovations in Parking Management*. Washington, DC: U.S. Urban Mass Transportation Administration. Report DOT-I-83-51, Jan. 1982. 19 p.
8. Parker, Martin, R. Jr., and M.J. Demetsky. *Evaluation of Parking Management Strategies for Urban Areas*. Charlottesville, VA: Virginia Highway and Transportation Research Council, Aug. 1980. v.p.
9. Communication from Von Musser, Rideshare Coordinator, City of Portland, OR. Jan. 2005.
10. Communication from Kathleen Anderson, Seattle Dept. of Transportation, Jan. 2005.
11. Institute of Transportation Engineers. *Residential Permit Parking*. Washington, DC: 2000. 16 p.
12. Transportation Research Board. *Transit Capacity and Quality of Service Manual*. Washington DC: 2004. 2nd Edition, Part 4.
13. Homburger, Wolfgang S. "Urban Transit." In: *Transportation and Traffic Engineering Handbook*. Englewood Cliffs, NJ: Prentice-Hall, 1982. Table 7-10.



## A. One-Way Streets

The establishment of one-way streets is an operational technique used to reduce congestion and delay by facilitating movement in and through an existing street network. A concomitant benefit is the reduction of certain types of accidents.

- 1 **History.** Archeologists have discovered that one-way streets were used in ancient Pompeii, making this one of the oldest forms of traffic control. In modern day America, the first one-way streets were installed in Philadelphia in 1906, followed closely by New York City (1907) and Boston (1908). Most urban areas now have one-way streets in their street networks.
- 2 **Legal Background.** One-way streets are generally established by local ordinances. The traffic engineer is directed to place and maintain traffic control devices, giving notice thereof. The *MUTCD* (Ref. 1) specifies the design and location of such signs.
- 3 **Advantages.**
  - a. Better utilization of existing streets by:
    - (1) Spreading the traffic load over more streets—an existing arterial may be overloaded while a parallel street, not developed as an arterial, carries little traffic.
    - (2) Better utilization of streets that are of such a width that they can accommodate an odd number of lanes.
  - b. Increased capacity at:
    - (1) Midblock by making it easier to pass double-parked and slow vehicles.
    - (2) Intersections by more efficient use of approach width and reduced turning conflicts (see Sec. C. below).
  - c. Improved safety through:
    - (1) Reducing the number of potential vehicle conflicts at intersections.
    - (2) Reducing the number of potential conflicts between turning vehicles and pedestrians at intersections. However, vehicles turning left out of one-way streets appear to hit pedestrians significantly more frequently than do all other turning vehicles, probably because of automobile roof support pillars blocking the view of the crosswalk that is parallel to the original direction of travel (Ref. 2)
    - (3) Practically eliminating the possibility of head-on collisions.
    - (4) Eliminating headlight glare from oncoming traffic.
  - d. Higher operating speeds, fewer stops, and less delay on signalized streets through improvement of signal system progression.
  - e. Better access to curb parking since motorists have a choice of either side of the street if spaces are available.

- f. Low cost of establishing and maintaining a one-way street system when compared to street widening or new construction projects; can be installed quickly.

A number of case studies conducted when major systems of one-way streets were installed in the 1950s indicated that travel speeds increased from 25% to 50%, and accidents decreased 25% to 50%.

#### 4 Disadvantages.

- a. Upgrading local streets to arterial status to form a couplet of two one-way streets may be incompatible with the land use along those streets.
- b. There will be longer trips for some vehicles, causing both inconvenience and overall increase in travel in the system.
- c. Elimination of turning movements at some intersections will increase turning volumes at others; this may create new control problems or move old problems to new locations.
- d. Additional control devices and replacement or alteration of existing control devices will be required.
- e. Difficulties in transit operations may arise:
  - (1) Transit stops for the same line will be separated by at least a block (instead of on opposite sides of a two-way street) causing some confusion to passengers.
  - (2) If the one-way streets forming a couplet are far apart (e.g., 270 m between north-south avenues in Manhattan), passengers may have to walk excessively far to or from transit lines.
  - (3) Where light rail operates, the installation of one-way streets may require extensive and expensive relocation of the transit infrastructure.
- f. One-way streets may be confusing to motorists:
  - (1) The initial installation requires extensive publicity and enforcement to change drivers' habits. After new traffic patterns are established, little difficulty is experienced by drivers familiar with the area. However, merchants and other commercial operators often dislike the concept of one-way streets, believing that potential customers may be lost.
  - (2) Drivers unfamiliar with the area are frequently confused, especially in areas with extensive one-way systems which do not have uniform patterns (e.g. San Francisco). Adequate regulatory signing (including turn prohibitions) reduce one-way violations, but guide signing and accurate maps may also be necessary to reduce confusion.

#### 5 Feasibility Studies.

An engineering evaluation is needed to determine the advisability of one-way operation in a given street network. Such a network may range in size from two parallel streets to all streets in an area. The evaluation includes:

- a. A physical inventory of the existing system to determine:
  - (1) Widths and adaptability to one-way operation.
  - (2) Termination points where end connections can be provided as necessary.
  - (3) Transit operations within the network.
  - (4) Existing traffic control devices and need for new devices.
  - (5) Land use and street characteristics on adjacent streets where volumes might change.
- b. Traffic volume studies on each street involved including:
  - (1) Hourly directional counts.
  - (2) Turning movement counts during peak hours at critical intersections.
  - (3) Counts on streets parallel to the one-way pair(s) being considered, to estimate possible redistribution of traffic.
- c. Speed and delay studies in both peak and off-peak periods to provide data on overall travel times and the locations and causes of major delays.

- d. Traffic signal studies to evaluate existing progression programs and to determine the improvement which might be gained from one-way operation.
- e. Parking studies to determine the feasibility of curb parking prohibitions on one or both sides at all times or only in peak periods as an alternative or supportive measure to one-way operation.
- f. Comparative capacity analyses of various alternative forms of operations.
  - (1) Capacity bottlenecks in the existing street network.
  - (2) Directional capacity of the existing network.
  - (3) Directional capacity of the proposed one-way network.
  - (4) Capacity increases using control methods other than one-way streets, e.g., parking prohibitions (Chap. 23), reversible or off-center movement (Sec. B and C below), or transportation systems management (TSM) measures.
- g. Estimates of added travel distance and increase in total travel in network.
- h. Feasibility studies with respect to transit routing and location of stops.
- i. Investigation of probable effect on movement of emergency vehicles.
- j. Investigation of probable effect of one-way operation on businesses, passenger loading zones (hotels, etc. may be on "wrong" side of street), parking facility entrances and/or exits, and other land use or curb use activities.
- k. Analysis of frequency, severity, and types of accidents along the proposed one-way streets, with estimates of possible decrease (or increase).
- l. Pedestrian and bicycle studies to evaluate impacts (if any) from one-way operation.
- m. Economic evaluation of costs of various types of operation in relation to the benefits that are anticipated.

#### **6 Intersection Capacity of One-Way Streets.**

- a. *The Highway Capacity Manual* (Ref. 3) does not deal with one-way streets specifically. However, by inserting the appropriate geometric data in the general methods for calculating the capacities of signalized and non-signalized intersections (Chaps. 15, 16, and 17 of Ref. 3), the capacity and level of service of one-way streets can be estimated.
- b. When evaluating one-way operation, one must compare the combined capacity of each pair of proposed one-way streets to the total of their capacities under existing two-way operation.

#### **7 Control Devices.**

- a. *Signs* (Ref. 1 contains detailed information).
  - (1) ONE WAY arrows or signs (usually four) are required at each intersection.
  - (2) NO LEFT TURN/NO RIGHT TURN signs are normally necessary on intersecting streets.
  - (3) DO NOT ENTER and TWO WAY TRAFFIC AHEAD signs are needed at transition locations or terminals of the one-way street.
  - (4) WRONG WAY signs are needed in the opposite direction of one-way traffic flow.

On the one-way street, additional control and warning signs are usually placed on the left to supplement signs in normal position on the right side of the roadway. Additional route markers and guide signs are frequently desirable.
- b. *Signals*.
  - (1) Usually, additional signals must be installed, especially if one street had not been developed as an arterial.
  - (2) New installations require fewer vehicle indications, but pedestrian indications must be installed facing those crosswalks not covered by vehicular signal faces.
  - (3) Existing signals may need modification for proper operation, including installation of additional vehicle detectors.

**8 Special Conditions Warranting Use of One-Way Streets:**

- a. As part of freeway or expressway design.
  - (1) One-way service or frontage roads, and one-way ramps (see Figs. 18-6b and 18-6c).
  - (2) Streets connecting one-way ramps, where several lanes in one direction are needed to balance the capacity of the ramp.
- b. Very narrow streets where two-way movement is impractical. Also most alleys.
- c. Rotary movement around a public square or roundabout.
- d. Complex intersections where one or more approaches are made one-way away from the intersection to reduce the number of conflicts and simplify signal operation.
- e. Single downtown blocks used for on-street bus layover points.

**9 Reversible One-Way Streets.** When an arterial street has an extreme imbalance in directional flow during peak periods—at least 80% of the traffic moving in the peak direction—and no adjacent street is capable of being utilized as one of a pair of one-way streets, reversible operation may be useful. (For somewhat less imbalance in demand—between 60% and 80% in the peak direction— see Sec. B below.)

- a. Normal operation is for the street to be one-way during peaks and two-way during off-peak.
- b. The minor flow must be accommodated by other streets during hours of one-way operation.
- c. Special signing is required. The *MUTCD* (Ref. 1) offers no suggested standard.
- d. Reversible one-way street operation is potentially hazardous; it must be carefully regulated and enforced to avoid accidents.
- e. This form of operation may be used on a temporary basis when streets are being reconstructed, and both directions of traffic cannot be accommodated during peak periods.

**B. Reversible Lane Operation on Streets and Bridges**

During peak periods, many major streets and bridges have an unbalanced directional traffic demand. If the directional split is greater than 60/40, it may be possible to devote more lanes to the major flow than to the minor one. On streets, removing parking on the side adjacent to the major flow will normally provide one additional travel lane. If this is impossible (as on most bridges) or insufficient, one or more moving traffic lanes may be reversed during peak periods to facilitate the major directional flow. Left turns from both directions of travel are usually prohibited during periods of reversible lane operation.

**1 Advantages:**

- a. Extra capacity is provided in the direction and at the time needed. Capacity increase results both from the addition of a travel lane and, if protected left-turn signal phases can be eliminated, from the increase in green time for through movements. Both morning and evening peaks can be accommodated on the same facility.
- b. No "paired" street developed to arterial standards is needed, as in the case of one-way streets. A bridge need not be widened or duplicated.
- c. The existing system of arterials is utilized more efficiently (e.g. two parallel arterials of 6 lanes when operated as a one-way pair provide 6 lanes in the peak direction; the same arterials both operated with 4-2 lane imbalance provide 8 lanes in the peak direction.)
- d. Minor direction traffic, including transit, does not have to shift to another street, as in the case of a reversible one-way street.

**2 Disadvantages:**

- a. Cost of installation (i.e. control devices) and operation (e.g. moving cones) may be high.
- b. Accidents may increase if the reversal is not clearly understood by drivers.

- c. Change-over problems before and after peak periods may be difficult to solve. Frequently, one or more lanes are temporarily removed from operation during the change-over.
  - d. Provision of adequate capacity for the minor direction may be difficult, especially on 4-lane facilities; on streets, curb parking prohibitions may be necessary, adding to enforcement costs and inconvenience to the public.
  - e. Access at intersections, minor cross streets, and driveways is restricted due to the prohibition of left turns.
  - f. Over a period of years, the imbalance in directional volume may become less pronounced. Monitoring directional volumes on a regular basis is important.
- 3 **Feasibility Studies.** General traffic studies required are the same as those described in Sec. A.5. for one-way streets. Additional factors favoring the use of reversible operation:
- a. lack of adequate adjacent streets rule out the consideration of one-way operation (e.g., a 6-lane arterial with all parallel streets being 2-lane residential streets).
  - b. wide streets or bridges (5 or more moving lanes) with ratios of major to minor directional flows exceeding 2 to 1.
  - c. a high proportion of commute traffic that desires to traverse the area without turns or stops.
  - d. terminal conditions that permit the full utilization of the additional lanes.
- 4 **Control Techniques.** Positive means of controlling lane usage is required on streets operated with reversible lanes. Techniques that have been used include:
- a. *Curb-Mounted Signs.* These may be adequate for streets where very few drivers unfamiliar with the area are in the traffic stream during the period of unbalanced operation.
  - b. *Overhead Signs.* Signs are mounted above the reversible lane(s) on overhead sign structures, mastarms, or span wire. The *MUTCD* (Ref. 1) standards for reversible lane control signs are found in Sec. 2B.23. Ground-mounted reversible lane control signs shall be used only as a supplement to overhead signs or signals and shall be identical in design to the overhead signs. They are used in conjunction with the signals discussed next, or by themselves.
  - c. *Lane-Use Control Signals* are a positive form of lane control. Standards for these signals are set forth in the *MUTCD* (Ref. 1, Secs. 4J.1 to 4J.5). California provisions for these signals are in California Vehicle Code § 21454.
    - (1) *Design and Meanings.* See Chap; 15, Sec. B.2.
    - (2) *Location.* A lane-direction-control signal head with a face for each direction of traffic is located over the center of each reversible lane at the beginning and end of the lane-controlled section. Confirming lane-direction-control signals over other lanes are optional. If the area to be controlled is more than 300 m in length, or if the vertical or horizontal alignment is curved, intermediate signal indications should be placed so that the motorist can see at least one and preferably two signal heads. At signalized intersections, the lane-direction-control signals must be placed in such a fashion as not to interfere with normal signal indications but still perform their function for traffic turning into the controlled section.
    - (3) *Operation.* All lane-control signals should be interconnected, so that the changes are controlled from one location. If all three color lenses are used, the normal transition is for the steady yellow X to be displayed for a sufficient interval to allow the lane to clear before permitting reversed flow. In two-lens installations (no yellow), the red X is displayed to both directions for sufficient time to assure that all vehicles have left the reversible lane. Change-overs should normally be made just prior to and just following the peak volume period. Signals should be wired so that red X is always indicated in one direction, unless 2-way left-turn operation is signalled by a flashing yellow X.
  - d. *Movable Pedestals, Tubes, or Traffic Cones, sometimes with KEEP RIGHT messages.* These are placed along lane lines to separate directions of traffic (see 5.a. and S.c. below). This method, although effective, is costly in terms of manpower since the devices must be placed in position and moved or removed for each peak period. This method is especially effective for temporary situations.



- e. *Movable Median Barrier.* A flexible movable median barrier consists of hinged individual sections about 1.8 m in length and resembling a concrete barrier (see Chap. 17, Sec. F7.a.) in cross section. A specially designed truck straddles this barrier and, traveling at a speed of about 8 km/h, moves it laterally 3.7 m from one lane line to the next.

**5 Reversible Lane Examples.**

- a. *Golden Gate Bridge, San Francisco.* The center two lanes of the six-lane bridge are reversible. In the morning they operate southbound, in the evening northbound, at other times normally (one in each direction). Lane separation is achieved by slender tubes protruding from holes located at regular intervals along lane lines. These tubes are placed and removed by crews traveling on trucks. Reversible lane operation also extends about 2 km on the San Francisco approach. Variable message signs alert approaching motorists about the lane assignment currently in force.
- b. *Auckland Harbor Bridge, New Zealand.* The movable median barrier, described in 4.e. above, is used to change the 8-lane bridge from a 4-4 to a 5-3 arrangement for each peak period, and to a 6-2 arrangement for traffic generated by special events.
- c. *Los Angeles.* On some major streets, traffic cones are used to obtain a 4-2 lane split during peaks. They are placed and picked up from a moving truck which converts the direction of flow as fast as the truck traverses the section.
- d. *Phoenix, AZ (Ref. 4).* A 10-km section of Seventh Avenue north of the CBD was converted from a permanently unbalanced lane configuration (three lanes northbound, two lanes southbound, left-turn pockets) by restriping the left-turn pocket area into a reversible lane. This lane operates as a southbound through lane in the morning peak, as a northbound through lane in the afternoon peak, and as a two-way left-turn lane at other times. A cost analysis determined that lane-use control signals would be too expensive; mastarm mounted signs over the new lane were used instead. A typical message is shown in Fig. 24-1. These signs are supplemented by curb-mounted signs; left-turn prohibitions were inaugurated at most signalized intersections during peak periods, but continue to be allowed at other intersections and mid-block driveways.

<b>6-9 A.M. MON-FRI</b>	<b>Do Not Use</b>
<b>4-6 P.M. MON-FRI</b>	<b>Thru Traffic</b>
<b>Other Times</b>	<b>2-Way Left</b>

**Fig. 24-1—Overhead Control Sign for Reversible Lanes in Phoenix**

Results included a significant increase of 24.6% in southbound morning peak traffic volume (which previously had only two through lanes), and a statistically insignificant increase of 16.2% in northbound afternoon peak volume. Accidents increased 25.8%, primarily because of an increase in collisions caused by improper left turns from the wrong lane (up from 4 "before" to 36 "after"), sideswipes (up 50%), and rear-end collisions (up 26%). Accidents involving correct left turns actually decreased 30%. Annual savings in reduced travel time were valued at about five times the annual cost of accidents and sign installation combined.

The success of the Seventh Avenue reversible lane led to the installation of another such lane on Seventh Street between McDowell Road and Dunlap Avenue.

- e. *Tucson, AZ* (Ref. 5). Tucson had approximately 16 km of peak-hour reversible lanes in operation using three basic techniques: signals with variable message signs, signs supplemented by traffic cones, and signs (Fig. 24-2) supplemented by advisory flashing beacons. Before-and-after studies generally had shown an increase in operating speed and reduction in travel time, and an increase in average daily traffic, without major changes in the accident rates. A study of accidents established that the reversible lane-related accident rate was basically the same for each of the three operational techniques employed. The majority of the accidents were left-turn related, even though left turns were prohibited on all reversible lanes.

The sign-only technique (with beacons) was very cost-effective when compared to the other techniques. The initial installation cost was relatively low, and annual maintenance is minimal. It was basically immune to vandalism and mechanical or electrical failures, making it the most reliable technique.

As of 2005, the City of Tucson Transportation Department was removing the reversible lanes temporarily to evaluate traffic operation without them.

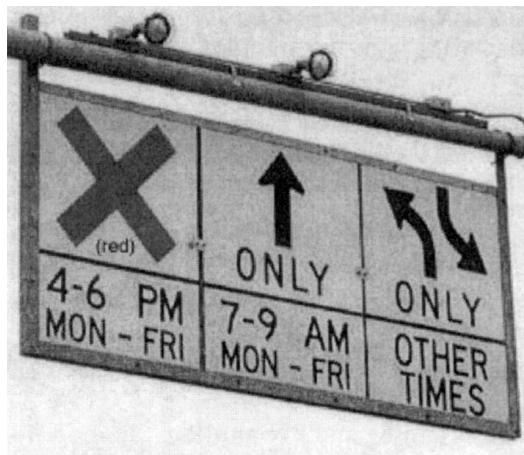

**Fig. 24-2—Overhead Control Sign for Reversible Lanes in Tucson**

### C. Permanent Off-Center Movement

Certain locations and circumstances may suggest permanently moving the centerline from its geometrically correct location to provide more lanes in one direction than in the other.

- 1 Streets 14–16 m wide with parking on both sides may be striped for three moving lanes—two in one direction and one in the other—rather than providing only one lane in each direction if the geometric centerline were to be retained. Other widths that can accommodate an odd number of lanes may also be striped in this fashion.
- 2 Off-center location of the centerline may be used in transition from one-way to two-way operation where traffic patterns permit.
- 3 A pair of streets that cannot be changed to one-way operation may be striped for permanent off-center movement to encourage traffic to use one street in one direction and the other in the opposite, while still permitting a minor amount of traffic to move against these major flows. Additional encouragement can be provided by progressive signal timing favoring the direction having more lanes.

## D. Two-Way Left-Turn Lanes (TWLTL)

On streets more than about 18 m in width and with block lengths of more than about 120 m it is sometimes feasible and desirable to replace the double center line or median by a special lane to be used by vehicles making midblock left turns from either direction. Such a lane is designated by pavement markings consisting of a pair of double yellow lines with the exterior ones solid and the interior ones dashed (see Ref. 1, Table 3B-7). These lanes are terminated short of intersections, where standard left-turn lanes, used only by traffic entering the intersection, are provided. Vehicle codes (e.g., California Vehicle Code, § 21460.5) require that, if such a lane is provided, all left turns be made from that lane.

The cities of Albany and Berkeley, CA, converted about 2 km of an arterial in a residential area from four lanes to two, and installed a two-way left-turn lane. At major intersections left-turn pockets were provided instead of the TWLTL. A year or so into the change, it appeared that the new street arrangement operates about as well as the previous one, except for congestion at the approaches to some intersections at peak periods.

## E. Preferential Treatment

Preferential treatment is a common method of Transportation Systems Management (TSM), directed toward achieving maximum efficiency—expressed in persons moved rather than vehicle flow—from existing facilities. In street operations, preferential treatment means giving priority to buses and other high occupancy vehicles (HOVs) in the traffic stream. (HOVs may include taxis, vans, and other motor vehicles with 2, 3, or 4 occupants. The definition of what constitutes an HOV varies by project.) In essence, it creates two classes of travel or two transportation systems within the same highway facility.

The concept itself is not new. Preferential treatment has been given to high occupancy vehicles, particularly streetcars, for a long time. The first such treatment for buses in the U.S. was recorded in 1939 on N. Sheridan Road in Chicago. By the mid 1950s, a number of other cities began to experiment with preferential treatment.

In outlying or residential areas there are few impediments to the smooth flow of transit vehicles. However, on major arterials and in the CBD, transit service is adversely affected by other components of the traffic stream. It is in such locations that one or more of the following treatments may be suitable.

- 1 **Careful Bus Stop Location.** Care in locating a bus stop can facilitate the bus's entry into it and reentry into traffic, thus minimizing time lost in serving the stop.
- 2 **Preference by Signing.** Turn prohibitions, particularly during peak periods, may exempt transit vehicles, facilitating transit routing. Intersection controls (e.g., STOP or YIELD signs) may be utilized to provide preference to the street carrying a transit route. Parking prohibitions near bus stops can facilitate bus operations.
- 3 **Preferential Traffic Signal Timing and Preemption.** Bus priority systems extend green intervals for a bus that stops either on the far side of the intersection or not at all. Signal timing plans can be prepared to favor bus progression. Systems have been implemented that permit buses to preempt traffic signals in the same manner as emergency vehicles and light rail transit.
- 4 **Terminals and Transfer Points.** Careful design of preferential entry and exit driveways serving bus terminals and transfer points can minimize delays for users of transit systems. Often, new intersections are created where driveways to the larger transit stations meet the existing street; these should be located to optimize both service to the driveway and operation of the street.

- 5 **With-Flow Curb Lanes.** One lane of an arterial street with curb side stops can accommodate more than 100 buses an hour with preferential treatment. This meets the needs of most locations; only the most densely traveled corridors in the largest cities have a greater demand.

It is relatively simple and inexpensive to implement exclusive curb lanes for buses operating in the direction of normal traffic flow. Where bus flow rates are high, the operation is self-enforcing. When bus volumes are low, other vehicles may try to use the lane. If right turns cannot be prohibited, they are accommodated by allowing vehicles to use the lane for about 30 m ahead of the intersection and by locating bus stops on the far side of the intersection.

- 6 **Contraflow Curb Lanes.** Operation of buses in the opposite direction to normal traffic flow on a one-way street has proven effective in a number of locations. Such a lane helps utilize unused capacity when peak flows are unbalanced, these lanes tend to be self-enforcing and usually provide higher operating speeds than normal flow lanes. There have been some reports of accidents, especially collisions of buses with pedestrians or vehicles entering the roadway and failing to look for buses coming from the contraflow direction (Refs. 6, 7). Examples of this type of operation include:

- a. San Francisco: a contraflow transit lane operates southbound on Sansome St. in the CBD.
- b. Minneapolis: contraflow lanes are marked with street-mounted signs at the end of each block.
- c. San Juan, Puerto Rico: a pair of contraflow lanes operate on two one-way streets more than 16 km in length. There is no physical separation.
- d. Seattle: double yellow stripes and DO NOT ENTER signs are used.
- e. Tel Aviv: contraflow transit lanes are also used by taxis and sheruts (a form of jitney). At times, loading and unloading taxis delay buses in these lanes.

- 7 **Contraflow Center Lanes.** Reserving interior lanes for transit use is quite complex and normally is suited only for express run segments. On Kalanianaʻole Avenue in Honolulu, a contraflow bus lane is provided on a two-way, four-lane, undivided section. Cones are used to separate the opposing flows. When the arterial becomes a six-lane divided arterial, the preferential lane is the median with-flow lane. Left turns are prohibited at most intersections during the period of preferential operation.

- 8 **Median Bus Lanes.** Bus lanes can be provided in or adjacent to medians on divided streets. Major problems in loading and unloading passengers limit most such lanes to express runs. A notable exception is New Orleans, where streetcar tracks in a wide median were replaced by bus lanes; this still allows buses to load and unload with adequate safety. Another median lane operation is on the six-lane section of Kalanianaʻole Avenue in Honolulu.

Still another type of median lane operation is the use of a center lane (perhaps a two-way left-turn lane or a reversible lane) as an exclusive bus lane during certain periods. Such an operation was in place on N.W. 7th Street in Miami prior to the opening of the 1-95 exclusive lanes (see Chapter 25). Buses preempted signals along the route. Estimates indicate a 20% increase in speed because of the signal preemption and an additional 10% increase because of the exclusive bus lane.

- 9 **Bus-Only Streets.** Streets reserved for buses are the most effective means of separating transit vehicles from other vehicular traffic. When implemented in conjunction with other improvements this can provide a very desirable focus for a major activity center as well as enhance the transit element. Washington, DC and Chicago have created short bus streets that act essentially as on-street terminals for several major routes. Examples of bus-only streets in downtown pedestrian mall areas include the Nicollet Mall in Minneapolis, 5th and 6th Avenues in Portland, OR, Chestnut St. in Philadelphia, and—albeit with LRT vehicles rather than buses—malls in Sacramento, Calgary, and Zürich.

- 10 **Street Light Rail Transit (LRT).** The track area on a street can be designated as an HOV or exclusive LRT lane. A more elaborate alternative is to separate the tracks from parallel lanes by curbs, with some intersections closed to crossing and left-turn traffic to reduce interference (e.g., Judah St., San Francisco).

- 11 **LRT Preferential Traffic Signal Timing and Preemption.** Intersection traffic signals along LRT routes can be equipped with preemption hardware that receives a signal from an approaching light-rail vehicle (LRV) and holds the green indication, if this is being displayed at that moment, or initiates a phase change if the cross street has the green. The total time saved by LRVs can be substantial if many signalized intersections are involved (e.g. in Portland, OR and San Diego, CA).

#### REFERENCES

1. U.S. Federal Highway Administration. *Manual on Uniform Traffic Control Devices: Millennium Edition*. Washington, DC: Government Printing Office, 2000.
2. Habib, P.A., et al. *Analysis of Pedestrian Crosswalk Safety on One-way Street Networks*. Washington, DC: U.S. Department of Transportation, Report DOT-OS-70057, Sept. 1978.
3. Transportation Research Board. *Highway Capacity Manual*. National Research Council. Washington, DC: 2000.
4. Lalani, N. and A.L. Baird. "Right Way for Wrong Way Driving". *ITE Journal*. v. 51, n. 4, April 1981, pp. 16-24.
5. Nassi, R.B. *Reversible Lane Control*. Unpublished Informational Staff Report. City of Tucson, AZ. 1985.
6. City of Los Angeles, Dept. of Traffic. *Accident Analysis: Contraflow Lane Experiment*. Los Angeles, CA: Staff Report 70.04, Sept. 1975.
7. Urban Mass Transportation Administration. *Accident Experience for Contra-Flow Bus Operations*. Washington, DC: 1975, unpublished manuscript.

## A. Introduction

Freeways are generally considered the most efficient type of highway for the movement of vehicles. Traffic on freeways differs from that on city streets and rural roads in that it moves at higher speeds (depending on traffic conditions, design standards, etc.), more smoothly, and at much higher rates of flow. Freeways were originally intended to serve longer trips of regional and interurban character along highways with full control of access. In urban areas, however, a high proportion of short trips may be found, resulting in high ramp volumes and a large number of merging, diverging, and weaving maneuvers, reducing the ability of freeways to serve their original purpose.

The expansion of freeway networks and of the number of vehicles that use them has created special problems that require special solutions beyond the standard design criteria. This chapter outlines these problems and some solutions that have been developed and implemented. Ref. 1 is a comprehensive report on urban freeway surveillance and control; Ref. 2 provides information on various freeway management systems operating in the United States.

## B. Operating Problems

- 1 **Congestion.** As mentioned in Chap. 4, freeways operate at full efficiency only if the traffic demand remains below the level at which flow becomes unstable. If flow rates become too high, the slightest disturbance will generate major congestion. This congestion may be recurrent, caused by inadequate capacity in relation to demands at peak hours, or nonrecurrent, caused by vehicle failure, accidents, weather, or other adverse events. Estimates indicate that one half or more of the delays on urban freeways are incident-related, and that overall delays on urban freeways are expected to increase steadily (Ref. 3).
- 2 **Vehicle Failure.** Vehicles may become disabled or come to an unexpected halt for a variety of reasons (out of gas, overheating, mechanical failure, etc.). A stopped vehicle on a city street or in a rural area often does not present a major traffic problem since it can usually be pulled out of the traffic stream into a parking space, onto a broad shoulder, or into a driveway. On many urban freeways, refuge areas for disabled cars are inadequate or nonexistent, and the vehicle must stop in the moving lane. This perturbs the smooth flow on all lanes of the same roadway, since traffic will have to change lanes to move past the stalled car. Even a vehicle stopped outside the moving lanes tends to slow approaching traffic. It can be dangerous for stalled motorists to leave their vehicles to summon aid. Passing motorists are not disposed to stop to help because of the hazardous conditions, although the wide use of cell phones has facilitated reporting and has increased the probability of a quick response to the failure. Tow trucks summoned for aid often find it time-consuming and difficult to reach the disabled vehicle.

- 3 **Accidents.** In addition to the problems caused by stopped vehicles cited above, vehicles involved in accidents often are not moved out of the line of traffic until police have completed an on-the-spot investigation. Usually, flares are set out, and traffic is routed around the accident areas, thus reducing the number of lanes available. Traffic flow is further reduced by motorists slowing to observe the accident scene. Even in states and localities where motorists are required to move their vehicles if they can be driven, there is a resistance to doing so until insurance formalities have been met. To reduce congestion problems in major urban areas, enforcement personnel often move the vehicles, or have them moved, as soon as they reach the scene.

Accidents with injury present the problem of routing ambulances or rendering first aid. Some accidents require cleaning the roadway to remove toxic materials, volatile liquids, slippery or bulky cargo spilled on the freeway, or accident debris.

Many accidents on freeways are of the rear-end type and often may involve a number of vehicles that have been following each other closely. One stalled vehicle or accident may multiply its effect by causing rear-end collisions. While the freeway is being cleared, secondary collisions may occur, or cars waiting behind the point of congestion may run out of gas or become overheated, causing additional problems. Other accident types include head-on collisions in freeway sections where medians are narrow and mountable, sideswipes caused by lane changing, and impacts with fixed objects, such as overpass abutments and columns.

- 4 **Materials Spills.** If the spilled substance cannot be identified immediately—because the vehicle causing the problem has left the scene or was not carrying appropriate material identification plaques—the freeway may have to be partially or completely closed until the material has been identified as harmless or has been removed. Major traffic tieups can occur in either case; the requirement to bring in special equipment and experts to remove toxic substances can cause additional delays. Even minor materials spills cause significant delays or hazards until they are removed.
- 5 **Enforcement.** Traffic law enforcement on freeways can be difficult because it is undesirable to stop a violator in heavy freeway traffic. Highway patrols operating on urban freeways often cite motorists only for the most flagrant or potentially dangerous violations, and then only if it is safe to do so. High speed chases in heavy traffic can cause corollary accidents among uninvolved motorists. Some agencies are providing enforcement areas along the freeway or designating off-site locations for accident investigation to reduce the effects on congestion. Operational controls, such as ramp metering or high-occupancy-vehicle (HOV) lanes, add to the demands on enforcement agencies; this often is not considered in freeway design.
- 6 **Maintenance.** Maintenance of any highway carrying heavy traffic is a problem. On freeways, it is usually necessary to take one or more lanes out of service in order to perform maintenance functions. Generally lanes are returned to service prior to peak periods. Traffic striping is often done on Sunday mornings. More and more maintenance is occurring at night or on weekends to reduce congestion; however, many agencies are concerned with potential accident problems associated with nighttime highway work.
- 7 **Freeway Reconstruction.** Many urban freeways built in the 1950s and 1960s now require major reconstruction. These projects have significant impacts on traffic flows in that they reduce the capacity of major links. Special traffic management programs, involving all modes of transportation in a corridor, are undertaken to mitigate the impacts of such reconstruction work.

### C. Operating Solutions

Some of the engineering solutions being used to resolve freeway operating problems are outlined below. The first four are appropriate for high-density traffic flows on urban freeways; they are components of the Advanced Traffic Management Systems (ATMS) of the Intelligent Transportation System (ITS) program. The others can be used both in urban and rural locations.

- 1 **Surveillance.** As the number and complexity of interconnecting freeways increases, an integrated, automated systems approach becomes essential and is being increasingly used. Traffic flow conditions can be surveyed by placing detectors at frequent intervals along freeways to measure the presence of vehicles and estimate their speeds. Inductive loops embedded under the roadway are currently the most common method of detection. However, other advanced detection technologies, including video-based imaging, acoustic, and radar systems, which are installed above the roadway, are gaining greater acceptance.

From these data, traffic density is calculated and locations at which density is approaching congestion levels can be identified. Incidents can also be identified by comparing data from successive sets of detectors and analyzing differences.

- 2 **Video Surveillance.** Closed-circuit television (CCTV) is an effective tool to confirm and monitor freeway accidents as well as construction, maintenance, and special events activities. Small, unobtrusive cameras are placed on poles or sign structures and, depending on location, can provide visual coverage of the freeway mainline, frontage roads, ramps, and cross streets. CCTV cameras are controlled from a traffic control center, from which operators can survey conditions along hundreds of kilometers of freeway. Current camera technologies provide high-resolution color images, even when operating at night under artificial illumination.
- 3 **Metering of Access.** A good control strategy for freeways subject to recurrent congestion is to reduce demand upstream of capacity bottlenecks to the point at which the density of the traffic stream remains below about 25 pc/lane/km. This is in the density range of Level of Service E. The number of vehicles permitted to enter the freeway at ramps upstream of the critical area is limited by traffic signals placed at these ramps. Under normal conditions they display a green indication or are turned off; when the rate of entry is to be reduced, the signal will turn red after each car passes and return to green only at calculated intervals. At the same time, signs on the streets leading to the ramp can advise motorists to seek alternate routes. This scheme is readily automated and placed under the control of a computer. Controls of this type, first used in Chicago in 1963, are now common in many urban areas. Recent applications include areawide strategies to reduce delays and to equitably allocate entrance constraints.
- 4 **Traveler Information Systems.** Current information about the state of the highway system can be conveyed to motorists in a number of ways.
  - a. Radio messages are often supplied by local radio stations from helicopters or fixed-wing aircraft. However, the accuracy and timeliness of these messages and, therefore, their usefulness vary.
  - b. Variable message signs can be used to regulate, warn, and guide:
    - (1) *Regulatory.* Variable speed limit signs may be employed to slow traffic through sections where an accident has occurred, or during periods of adverse weather. Other variable message signs are used, perhaps in conjunction with gates, to close freeway ramps to reversible roadways. These devices may also be used elsewhere to close ramps during emergencies, and to designate HOV restrictions.
    - (2) *Guide and Warning.* These signs may be used to warn traffic of adverse weather conditions or congestion problems ahead. Signs may also be used to provide alternate route guidance, end of queue protection, or general motorist information during incidents.
    - (3) *Example of a Major Installation.* The INFORM (INformation FOR Motorists) system covers the 60 km central corridor on Long Island, New York. The system provides traffic information 24 hours a day, 365 days a year. INFORM has its headquarters in the Traffic Management Center in Hauppauge, New York. Becoming operational in the mid-1980s, by 1996 the system included 2,400 loop detectors, 101 variable message signs, 75 ramp meters, and 49 CCTV cameras. The system provides motorists with advisory information on roadway conditions and advises police and emergency organizations of traffic incidents.



- c. *In-Vehicle Guidance.* In-vehicle computerized map display systems are being offered by most automobile manufacturers. These utilize global positioning systems (GPS) technology to monitor vehicle location and assist drivers in navigating on the roadway network. Future systems will incorporate real-time traffic condition information to allow drivers to find routes that offer the shortest travel time to their destination.
  - d. *Trip Planning Systems.* Utilizing advanced data processing, traffic surveillance, and communications technologies, a wide array of traveler information systems are being developed and implemented. Traffic information, including transit schedules, congestion locations, weather and roadway conditions, and construction and maintenance activities can be accessed by personal computers using the Internet, by telephone, or through interactive, computer-based kiosks. These systems allow motorists to determine which route or mode is the most appropriate prior to setting out on their trip. Development of information databases that provide a regional picture of conditions on the transportation system typically requires the installation of expanded surveillance capabilities, a centralized database, and a high level of inter-agency coordination and cooperation.
- 5 **Roadside Call Boxes.** Roadside communication devices can be used to provide assistance to motorists stalled or disabled on freeways. As part of a motorist aid system, call boxes permit motorists to communicate their location and need to a central agency capable of dispatching the necessary response equipment or service. After some teething problems in the late 1970s, major programs were undertaken. California, for example, allows counties to place a surcharge on vehicle registrations to pay for call box installation; this program was implemented in almost all urban counties in the State. However, the proliferation of cell phones available to report freeway incidents has reduced the use of call boxes since 2004, and the culling of perhaps half of the boxes has been announced.

There are two common forms of call boxes: push-button and two-way voice. They can be powered by solar-powered battery or mechanical means. The communication medium can be either radio or landline (owned or leased). Characteristically, half or full-duplex voice systems permit users to speak directly with a central dispatch terminal to describe their needs, location, and request for service. These devices usually feature a telephone handset. The most recent voice call box systems in urban areas use solar powered cellular telephones to reduce implementation time and cost.

Call boxes are installed on frangible supports on roadway shoulders, oriented so that users face oncoming traffic. Spacing between call boxes has usually been 0.8 to 1.6 km—ranging from 0.4 km on Los Angeles freeways to several kilometers on rural facilities—but is likely to perhaps double. Normally, call box units are provided on opposite shoulders to accommodate both directions of travel. Additional call boxes in the median are sometimes desirable for facilities with three or more lanes in each direction, and where left-side shoulders are available. Ref. 4 contains more information.

- 6 **Aircraft Patrols.** Used in major cities during peak hours, helicopter or fixed-wing aircraft patrols are an expensive but reasonably effective way of spotting trouble, relaying information to commercial broadcast or control centers, and suggesting alternate routes. Radio stations often finance and operate these patrols. In rural areas, aircraft are also used for spotting speeding violators.
- 7 **Service Patrols.** Both publicly and privately operated service patrols are being used in some areas to reduce detection and response times for aiding motorists. The service periods may range from those provided only on special occasions to publicly provided patrols during peak periods (over 650 km in Los Angeles) to 24-hour services.
- 8 **Incident Management.** Freeway incident management is an important concern particularly on urban freeways operating near, at, or beyond their capacities during peak periods. An accident, spill, or stalled vehicle, for example, can degrade highway performance as well as create extremely hazardous situations for involved motorists and approaching or passing traffic. The major thrust in incident management is to maintain continuity in traffic flow through real time

detection, to effect prompt removal of any traffic flow impediment, and to safeguard the incident site from secondary incidents through such traffic control measures as flares, changeable message signs, highway advisory radio, route diversion, or contraflow.

- a. *Advanced Technology.* Early detection strategies that can be applied include those detailed in C. 1, 2, 5, 6, and 7 above. These strategies are fundamentally "high technology" concepts and will become more available with implementation of automated detection and control systems.
  - b. *Highway Patrols.* State Highway Patrols have been, and continue to be, a traditional source for incident detection. These patrol vehicles also function as "traffic managers" at the incident site. The time-to-detection depends on patrol headways and travel speed. Where the need for extremely rapid detection time is crucial, detection by patrol is labor-intensive and can become prohibitively expensive. As congestion levels increase, patrols become increasingly more cost effective and are likely to be applied more extensively.
  - c. *Cell Phones and Citizen Band Radio.* The widespread presence of mobile CB radios and cell phones in private autos and trucks has added an important resource to incident detection. Some state highway patrol agencies furnish patrol vehicles and base stations with CB equipment in order to detect and respond to freeway incidents reported by passing motorists. Access to emergency services is increased with direct dial to service providers and use of the "911" general emergency services number. In urban areas, the majority of significant incidents are now reported by cell phone.
  - d. *System Concept.* Research has investigated all aspects of the system concept for incident management. Detailed analysis of operational solutions for the detection, removal, and safe-guarding of incident sites were also conducted. Details are contained in Ref. 5.
  - e. *Management Teams.* Several urban areas have organized inter-agency teams to plan and coordinate responses to major incidents. Membership typically includes state highway and police agencies and local police, fire, and traffic management departments.
  - f. *Traffic Operations Centers (TOC).* Centralization of incident management operations has proven effective in reducing incident response time. TOC operators monitor freeway conditions 24 hours a day and, utilizing video surveillance cameras and vehicle detection systems, can identify and confirm incidents and dispatch appropriate assistance (i.e., tow truck, police, fire, ambulance, or hazardous materials units).
- 9 **Integrated Freeway Corridors.** In highly congested freeway corridors, state and local agencies often develop integrated operation strategies to maximize the utilization of corridor capacity, including both the freeway and parallel arterials by expanding the traffic surveillance, control, and traveler information systems of both freeway and arterial networks. One of the first fully integrated, or "Smart" freeway corridors is a 16-km section of the Santa Monica Freeway (I-10) in Los Angeles. Using a high degree of automation, Caltrans, the California Highway Patrol, and three municipalities coordinate freeway and arterial operations so as to balance traffic flows on each corridor facility. This is particularly beneficial when an incident occurs on the freeway, and its value was proven when bridges on I-10 collapsed during the Northridge Earthquake of 1994.

#### D. Preferential Treatment (Refs. 6 and 7)

Planned, designed, and built to meet transportation needs in major corridors, freeways create a concentration of travel desires. This makes freeways prime candidates for preferential treatment of high occupancy vehicles (HOVs) to accomplish the maximum utilization in terms of person-trips per hour for these expensive and elaborate facilities.

HOVs include buses, cars with multiple occupants (in some instances, only two), vanpools, and carpools. As of 2005, qualified single-occupancy hybrid vehicles were permitted to use HOV lanes in California and Virginia. They must display a state-issued decal.

- 1 **Express Bus Operation.** Express bus operation on freeways is a simple and relatively inexpensive method of improving transit service in a corridor. Typical locations for stops include major transit transfer points, fringe parking lots, major commercial, industrial or institutional traffic generators, and high-density residential complexes.

Stops are usually placed at interchanges. It is important to keep walking distances between transit trip destinations and the bus stops short. If more than a few minutes of walking are involved, the traffic generator will not be well served by a bus stop at the freeway level. At diamond interchanges stops may be at the intersection of the ramps and the cross street, in which case preferential treatment may call for preemption capabilities of the traffic signal at this point; signals can be actuated to favor buses by means of detector loops at the bus stop if this is in a lane from which other traffic is excluded, or by special preemption devices where mixed traffic flow is present. At more complex interchanges, where leaving and reentering the freeway is unduly circuitous and time-consuming, special loading zones can be provided within the freeway right-of-way by constructing short connectors between an off-ramp and an on-ramp or, in special situations, by building a separate lane leading to and from the loading zone (Ref. 8). In all cases, adequate parking or transfer opportunity is required.

Without other preferential treatment of the types described below, express bus service of this type becomes less effective as congestion on the freeway increases.

- 2 **Ramp Bypasses.** During hours of traffic congestion, especially on freeways in and near the central city, queue build-up on ramps may become significant. If ramp metering, as described above, is used, queue lengths will increase still further. Ramp closures during peak periods add to the pressure on the remaining ramps. Buses and other HOVs in mixed traffic streams are subjected to delays caused by these conditions. One form of preferential treatment is to arrange for HOV ramp bypasses around queues waiting to enter the freeway. In special situations, entire ramps may be restricted to HOVs during peak periods.
  - a. On I-35 in Minneapolis and I-25 and I-225 in Denver, exclusive bus ramps that bypass the main metered ramps have been constructed. Bus ridership has increased dramatically, but time savings are nominal. Other ramps permit carpools as well.
  - c. In California, ramps and ramp shoulders have been restriped to permit buses and carpools to bypass queues forming upstream of the metering signal.

As transportation demand continues to grow, greater need for converting ramps during peak periods to the exclusive use by buses and other HOVs will develop. However, HOV-ramp bypasses are subject to misuse. A study in Seattle WA (Ref. 9) suggests that approximately 40% of HOV bypass users were in violation of the required vehicle occupancy (auto with 3+ persons; buses and motorcycles also allowed). Frequency and duration of enforcement affects the violation rate.

- 3 **Congestion Bypasses.** On some freeway systems, bottlenecks restrict flow and cause queuing and delay. Bypass routings for buses and HOVs can effectively reduce travel time.

A unique congestion bypass is found on the east approach to the San Francisco-Oakland Bay Bridge. The system was designed to obtain more efficient traffic flow and give priority to buses and 3+ person carpools entering the five-lane westbound bridge deck. HOV lanes, bypassing the 20-lane toll plaza on the north, are open to buses at all times and to van- and carpools during five morning and four afternoon peak hours, when these vehicles are exempt from tolls. During these same peak periods, the two most southerly toll lanes are also reserved for HOVs. HOVs always have the green light through the metering system that limits the rate of flow beyond the toll plaza from the other lanes onto the bridge. Although HOVs may be delayed until they reach the beginning of the priority lane, they still save 10-20 minutes during the peak.

- 4 **With-Flow Exclusive Lanes.** In this treatment, one or more lanes are designated for buses only or for HOVs only. In most cases it is the left (median) lane of the facility. When the reserved lane is newly constructed or added by paving shoulders, narrowing lanes, or other means, it is generally accepted by the public. When an existing lane is removed from general service to serve HOVs only, especially in a congested area, a high degree of controversy can be expected.

Bus and HOV lanes will attract an increased number of transit users and carpools providing there is a significant savings in travel time relative to the normal traffic stream, or travel time predictability is improved. Where remaining lanes flow in an uncongested manner, the benefits of the priority lanes are lost. Priority lanes that are not physically separated from normal travel lanes may experience high violation rates (up to 80%), which cannot be considered a desirable situation even though a time saving is achieved. Installation of narrow (0.3–1.2 m wide) painted dividers with restricted points of access are being used in Southern California to reduce violation rates and have proved very effective. Safety aspects of adjacent lanes traveling at significantly different speeds are a prime concern. The lack of safe enforcement pull-out areas makes it difficult for police officers to maintain adequate enforcement levels, which contributes to high violation rates.

- a. In the 1980s, the median shoulder of I-95 in Miami was reconstructed for exclusive use of buses and carpools. Low utilization early in the project prompted officials to reduce the carpool definition from 3 or more to 2 or more persons. The system has been improved to its current status of providing an HOV lane of full width (plus median shoulder) in each direction for peak period operation, 7 to 9 am southbound and 4 to 6 pm northbound. The system now extends some 75 km from SR 112 in Miami-Dade County to Linton Blvd in Palm Beach County.
- b. SR 520 serves as a major corridor across Lake Washington in Seattle. In 1973, the right shoulder was designated for buses only for a distance of 2.9 km approaching a toll plaza. The lane was later opened to carpools of 3 or more. After the toll plaza was removed, the HOV lane continued to provide time savings to users and in 1980 was extended an additional 1.9 km to the interchange with the I-405 freeway. One problem was that the right-side location of the HOV lane requires the crossing of four on-ramps and one off-ramp.
- c. The median lane in each direction on the Moanalua Freeway in Honolulu is reserved for buses and carpools. These lanes were constructed as new lanes for general use but designated as preferential lanes when construction was completed. They are heavily used by carpools, and up to 5 minutes in travel time are saved over a 4.3-km section. Violations are approximately 15%. In 1998 a moveable barrier system was installed along a portion of the freeway in the vicinity of Pearl Harbor to provide an additional lane in the heavy flow direction during commute periods for vehicles with 3 or more occupants.
- d. No discussion of with-flow reserved lanes would be complete without mention of the Santa Monica Freeway Diamond Lane. The project covered a 20-km section of the 10-lane Santa Monica Freeway in Los Angeles. The median existing lane in each direction was reserved for buses and 3 or more person carpools from 6:30 to 9:30 am and 3 to 7 pm. The project created heated and continuous controversy. After 21 weeks of operation, it was halted by a U.S. District Court judge who ordered additional environmental studies; the project was then abandoned. A summary of the evaluation study findings (Refs. 10 and 11) follows:
  - (1) *Travel patterns:* Nearly 3% more people were traveling on the Santa Monica Freeway in the morning and evening peak periods in the 21st week in 7% fewer cars, compared to the period before the project was initiated. In the final week, carpools totaled 269% of the number before the project. Transit bus patronage more than tripled in the 21 weeks of the lane's operation. About 16.9% of all persons using the freeway in peak hours were riding in buses or carpools in the 21st week, compared to 6.3% before the lane was opened. Traffic on parallel city streets at the end of the 18th week (the date of the last count) was 10% less than preproject in the morning eastbound direction and 2.9% more in the evening westbound.
  - (2) *Travel time:* Average freeway travel time for single-occupant vehicles traveling the full length of the project over the last 19 weeks of the project was virtually the same as preproject during the am peak period eastbound. In the pm peak period westbound, travel time increased by 24 s. Average total travel time, including delay for trips entering

the freeway at on-ramps within the project, was less than before the project, with the exception of traffic entering westbound at La Cienega. The maximum total travel time savings for bus and carpool riders whose trips started at ramps within the project was 5 minutes. Bypass lanes at metered ramps saved carpools and buses between 5 and 11 minutes.

- (3) *Accidents*: Accidents occurred at a higher rate than before the project. Most were of the "rear end" type and occurred in the lane next to the Diamond Lane. Accidents occurred nearly twice as often in the afternoon as in the morning.
- (4) *Violations*: Diamond Lane ranged violations generally from 10% to 19% of total Diamond Lane traffic and constituted about 1% of all freeway traffic.

5 **Contraflow Exclusive Lanes.** On many radial freeways, when the peak flow direction is heavily congested, lanes in the offpeak direction are largely unused. Utilizing one lane in the offpeak direction for peak flow travel provides a large increase in capacity.

- a. One of the earliest and most successful contraflow lanes is a 4-km segment of I-495 connecting the New Jersey Turnpike and the New Jersey portal of the Lincoln Tunnel. In operation since 1970, it carries traffic inbound during the morning peak period only. The contraflow lane is separated from outbound lanes by traffic delineators and overhead traffic devices. During the peak hour the lane carries 725 buses with 34,700 passengers. Elsewhere in the New York Metropolitan Area, similar contraflow lanes are used on the Long Island and Gowanus Expressways.
- b. Houston, TX, operates one of the world's most extensive systems of freeway contraflow reversible HOV lanes (Ref. 12). This system, initiated in 1979, is based principally on a single reversible lane, 6.1 m wide, with barriers on both sides. A total of 151 lane-km were operational in 2003.

This system of reversible lanes is called "Transitways." The lanes are open for inbound flow from 5 to 11 am and outbound from 2 to 8 pm. The Katy Transitway on I-10 also operates on weekends. Vehicles allowed to use the transitways include buses, motorcycles, certain public agency vehicles, and vanpools and carpools with two or more persons. On two Transitways, high demand has resulted in requiring three or more persons for peak periods in order to restore higher speeds and keep trip times reliable.

In 1999, the transitway system carried 88,000 person-trips per day. About 32% were in buses, 3% in vanpools, and 65% in carpools.

6 **Exclusive Rights-of-Way.** Separated roadways exclusively devoted to HOVs provide the highest level of service in terms of moving people in buses and carpools. Many exclusive roadways are part of freeways or on freeway rights-of-way while others take advantage of abandoned railroad rights-of-way or other natural features to provide a separate way.

- a. *The Shirley Highway* (Ref. 13). This major radial freeway (I-395) between downtown Washington and suburban Virginia varies from 8 to 10 lanes in width, with the cross section being 3-2-3 or 4-2-4 (inbound, reversible, outbound). The two reversible lanes, 48 km long, are in the median and are separated from other lanes by concrete barriers. They were initially restricted to buses, but in 1973 4-plus person carpools were allowed to use them when it was found that the buses did not utilize the available capacity. In January 1989 the occupancy requirement was lowered to three or more. Entrance and exit to the facility are at separate, exclusive ramps. The reversible lanes operate inbound in the morning and outbound in the evening.
- b. *I-66 in Northern Virginia* (Ref. 14). Sixteen kilometers of this freeway between the Capital Beltway and Washington, D.C., were opened in 1982. This was the first project in the U.S. to use the terminology "HOV" in signs and markings. It is unique in that during peak periods the entire roadway in the peak direction of flow is restricted to buses and carpools. The off-peak direction is not restricted. (A rail rapid transit line uses the median.) Starting in 2005, hybrid-fuel vehicles with Virginia plates were allowed to use the HOV lanes without meeting occupancy requirements.

Originally designated for carpools of four or more persons, political pressures forced a reduction to three or more in 1984 for a one-year demonstration project. In early 1990 there were 1,900 carpools, vanpools, and Dulles Airport vehicles in the peak hour and 4,500 vehicles in the peak period, including many violators at the fringes of the restricted period. As of 2005, a two-plus person rule was in effect.

A surveillance and control center monitors all movements on I-66 (as well as on I-95 and I-395) and regulates flow through ramp metering. Overhead changeable message signs alert motorists to HOV restrictions as well as to general traffic conditions.

- c. *The Ottawa (Canada) River Parkway.* On this parkway, a 7.2-km section of one roadway is closed to all traffic except buses during peak periods: from 6:30 to 9:30 am two-way bus traffic has exclusive use of the outbound 2-lane roadway; from 3:30 to 6:30 pm the inbound roadway is used. Traffic desiring to travel in the offpeak direction must find other routes. To accommodate the various turning movements to and from the Parkway, some median crossovers and short sections of new ramps had to be built. In addition, exclusive bus ramps were added to connect the Parkway to the CBD.
- d. *The El Monte Busway* (Ref. 15), extending eastward from downtown Los Angeles along the San Bernardino Freeway, consists of three sections of quite different design:
  - (1) At the edge of downtown, a bridge crossing the Los Angeles River and a number of railroad tracks is on a completely separate alignment.
  - (2) The next 6.4 km consist of two separate roadways outside the right-of-way of the freeway lanes; each roadway is striped for one running and one emergency stopping lane. Operation is by driving on the left because of bus stations with center platforms located adjacent to a county medical center and near a state university campus. Pedestrians reach the bus platforms by bridges and elevators. Carpools and express buses can bypass the stations.
  - (3) The easterly section extends for 11 km in the median of the freeway, in which a single freight railroad track is also accommodated. The HOV lanes are separated from the other freeway lanes by paved buffer lanes in which rows of tubes are placed to prevent use by traffic. The transition from the adjacent section and from left-side to right-side driving is via grade separation structures. A flyover ramp in the middle of this section connects the busway to Del Mar Ave. At the outer end, the busway leaves the median via an underpass and enters an off-street transit terminal, at which a large park-and-ride lot and a direct connection to bus storage and maintenance facility are provided.

When the project was opened in 1973, about 1,800 persons had been using buses in this corridor daily. This number had risen to 22,000 in 1987, with peak hour one-direction volumes of more than 3,700. In 1976 the busway was opened to carpools of three or more persons. After two months, about 750 carpools were counted in the peak direction during the peak four hours; this number has increased steadily since then to 2,200, and is approaching the capacity of the lane during the peak 30 minutes. Violation rates are about 7.5%.

- e. *The South Busway* in Pittsburgh, PA, links downtown Pittsburgh with the South Hills area. The 7.2-km facility serves express and local trips; for the latter several on-line bus stops have been provided. There are two intermediate access points via exclusive ramps. Approximately half of the Busway is on a separate roadway, and the other half shares the right-of-way with several LRT lines. This joint utilization is particularly important through the Mount Washington Tunnel, allowing buses to bypass the heavily congested Liberty Tunnel.

The 14.5-km *East Busway* in the northeast section of Pittsburgh re-opened to traffic in June 2003. A busway shuttle route provides local service to neighborhoods and provides express buses between several suburban municipalities and downtown Pittsburgh using a series of exit/entrance ramps spaced along the Busway.

The *West Busway*, 8 km long, began operation in September 2000. It connects downtown with suburbs to the west, serving business centers of towns along the way.

- 7 **High Occupancy/Toll(HOT)Lanes** (Ref. 16). HOT lanes are a new variant on HOV facilities; vehicles can use HOV lanes by paying a toll, a transportation concept called "value pricing," which allows motorists to choose between paying for access to uncongested dedicated lanes versus riding for free on parallel lanes that are congested. Tolls can rise and fall, depending on demand. The objective is to keep the HOT lanes free-flowing at all times through adjusting charges.
- a. *SR 91 Express Lanes*. These lanes, opened in 1995, were the first to use value pricing in the United States. Two toll lanes were built in each direction in the median of SR 91, an existing eight-lane freeway connecting Riverside and Orange counties, for a distance of 16 km. By 2004 the highest tolls, which are varied according to congestion levels, were \$5.50 for a 16-km trip. A beneficial effect of the HOT lanes is that congestion in the free lanes has diminished, especially in the afternoon peak. Tolls are collected electronically via transponders.
  - b. *I-15 HOV Lanes*. This facility consists of two reversible lanes in the median of I-15 about 16 km north of San Diego. The lanes are 13 km long and have been in operation since 1988. In late 1996, single-occupant autos were allowed to use the lanes with the purchase of a monthly permit. The number of permits sold was gradually increased and peak period traffic conditions monitored to ensure that LOS C or better was being maintained. In 1998 the flat-rate monthly charge was replaced by a per-trip toll that varies depending on traffic; it is collected electronically.
- 8 **Casual Carpools**. Success of one or a combination of the above strategies can sometimes lead to an unexpected side effect; the appearance of casual carpooling (Ref. 17). This phenomenon is quite extensive in several areas, including the Shirley Highway corridor of Washington, D.C., and in the Bay Bridge corridor of the San Francisco Bay Area. Carpool vehicles save so much time (and, in the case of the Bay Bridge, tolls), that drivers who do not participate in formal carpools are willing to pick up strangers en route to work in the morning. The passengers, in turn, gain by not having to pay a transit fare and by obtaining a prompt and comfortable ride. Pickup points often develop by word of mouth at or near transit stops (transit being the fall-back alternative for the passengers); in some locations, local government has established loading areas for casual carpools because of the queues of car that tend to form there. Passengers are dropped off at or near the downtown location where the transit system would have delivered them.

Casual carpooling contributes to the use of HOV lanes, but transit systems lose revenues. If these losses can be balanced by cancelling expensive peak period service, the transit system is no worse off. But this is not always possible, and never is the case in rail systems. Some casual carpool drivers have also deserted transit, and it is likely that there is a net increase in passenger car travel. Therefore, while this mode of commuting is obviously popular, it may not achieve goals of reducing congestion, fuel consumption, and air pollution.

#### REFERENCES

1. Homburger, W.S. et al. (editors). *Proceedings of the International Symposium on Traffic Control Systems*. Berkeley, CA: University of California, Institute of Transportation Studies, 1979. 5 vols.
2. Transportation Research Board. "Symposium on Integrated Traffic Management Systems" *Transportation Research Circular 404*, March 1993.
3. Lindley, Jeffrey A. "Urban Freeway Congestion: Quantification of the Problem and Effectiveness of Potential Solutions." *ITE Journal*, v. 57, n. 1, Jan. 1987, pp. 27-32.
4. Kell, J.H. and I.J. Fullerton. *Motorist Aid Systems—FHWA Policy Report*. Washington, DC: U.S. Department of Transportation, September 1976. 199 p.
5. Urbanek, G.L., Abrams C.M., et al., *Alternative Surveillance Concepts and Methods for Freeway Incident Management* (6 vols), Washington, DC and Alexandria, VA., FHWA, Peat, Marwick, Mitchell & Co., JHK & Associates, May 1977 - April 1978 (FHWA-RD-77-58 through 63).

6. Transportation Systems Center. *Priority Treatments for High Occupancy Vehicles*. Cambridge, MA: U.S. Department of Transportation, 1976.
7. Rothenberg, M.J. & Samdahl, D.R., *Evaluation of Priority Treatments for High Occupancy Vehicles*. Alexandria, VA., JHK & Associates, 1980 (FHWA-RD-80-062).
8. American Association of State Highway and Transportation Officials. *Guide for the Design of High Occupancy Vehicle and Public Transfer Facilities*, Washington, DC: 1983. 100 p.
9. Newman, B.R., S.S. Washburn, and N.L.Nihan. "Motorist Behavior and Opinions Toward High-Occupancy Vehicle Lanes at Ramp Meters." *Transportation Research Record* 1634, 1998, pp. -85.
10. California Department of Transportation. *Evaluation Report on the Santa Monica Freeway Diamond Lane Project After 21 Weeks of Operation*. Sacramento, CA, 1976. 39 p.
11. Billheimer, J.W., et al., *The Santa Monica Freeway Diamond Lanes*. (2 vols.). Los Altos, CA., SYSTAN, Inc., Sept. 1977 (UMTA-MA-06-0049-77-12 & 13).
12. Texas Transportation Institute. *Houston High Occupancy Vehicle Lane Operations Summary*. Houston, TX: METRO, Sept. 1999.
13. JHK & Associates. *Transportation and Environmental Studies of the I-66 and I-395 HOV Facilities: The Operation of I-395*. Alexandria, VA: 1985.
14. JHK & Associates. *Transportation and Environmental Studies of the I-66 and I-395 HOV Facilities: The Operation of I-66*. Alexandria, VA: 1985.
15. California Department of Transportation. *California Ridesharing Facilities*. Sacramento, CA: Jan. 1984.
16. ITE Task Force. "High-Occupancy Toll (HOT) Lanes and Value Pricing: A Preliminary Assessment." *ITE Journal*, v.68, n. 6, June 1998. Pp. 30-40.
17. Homburger, W. and A. Stevens. "Casual Car Pooling: A New Concept in Urban Commuting." [*Compendium of Technical Papers.*] *Institute of Transportation Engineers, District 6/District 7 Joint Annual Meeting*. Vancouver, BC: July 1986, pp. 7-29 — 7-40.





## A. General

"The primary function of temporary traffic control is to provide for the safe and efficient movement of vehicles, bicyclists, and pedestrians through or around temporary traffic control zones while reasonably protecting workers and equipment" (Ref. 1, Part VI). The area where highway construction, maintenance operations, utility work, or incident management suspends the normal function of the roadway is known as the work zone.

The work zone encompasses the area from the first sign to the last sign in the temporary traffic control zone (TTCZ). Work zone practitioners must balance the needs of the contractor or maintenance operation and the safety of workers and road users. The majority of work zone material in this chapter is covered in Part VI of the *MUTCD*. (Ref. 1)

## A. User Satisfaction, Congestion, and Collisions

- 1 **User Satisfaction.** A study by FHWA, entitled *2000 Omnibus Traveler Survey*, rated the number one motorist frustration due to delays on highways as "Heavy Traffic" followed closely by "Road Work," i.e., work zones (Ref. 2). While more than 75% of respondents were satisfied with signing, safety features, and detour signs and directions, more than 50% were dissatisfied with speed of repairs, traffic congestion, and time delays associated with work zones.
- 2 **Congestion.** FHWA estimates that 20% of the over-260,000 km of the National Highway System (NHS) is under construction during the peak summer roadwork season (Ref. 3). Also, motorists are traveling more km annually. The combination of more work zones coupled with more traffic equates to more delay and more user costs attributed to work zones.
- 3 **Collisions.** According to the FHWA's 2002 Fatality Analysis Reporting System (FARS), there were 1,181 fatalities in work zones (Table 26-1, Ref. 4). This was 9% above the number of fatalities in 2001 (1,079). (In 2003, the number had decreased to below the 2001 level at 1,020). It is estimated that approximately 15 – 20% of the total are highway workers. The majority of fatalities were drivers at 58%, followed by passengers at 29%, pedestrians at 11%, pedalcyclists at 1%, and other less than 1%. From 1999 through 2003, the average work zone fatalities were 1,020 persons per year.
- 4 **Causes of Work Zone Collisions.** Fixed-object collisions increase in work zones. The incidents usually show the greatest concentrations near the taper and work area where channelizing devices are used. The results of these analyses are revealing when considering the motorist informational needs in each area of the work zone.

In advance of the work area, where drivers are slowing, there is a high percentage of rear-end crashes. In the transition area where channelizing devices are first introduced, the percentage of fixed-object incidents increases. In the work area, where the work and traffic must be sep-

arated, although rear-end and fixed-object crashes constitute a large percentage, sideswipe incidents also emerge as a sizeable percentage of the crashes.

**Table 26-1 — Work Zone Fatalities by Functional Classification, 2002**

Roadway Class	Driver	Passenger	Pedestrian	Pedalcyclist	Other	Total
Interstate	179	143	39	1	0	361
Freeway	44	19	7	0	2	72
Principal Arterial	193	80	35	4	1	313
Minor Arterial	105	39	24	3	0	171
Collector	84	33	10	2	1	132
Local Street	71	24	20	4	0	119
Unknown	8	5	0	0	0	13
Total	684	345	134	14	4	1181

Source Ref. 4.

### C. Fundamental Principles

The principles which have been shown to enhance the safety of road users, pedestrians, and workers in the vicinity of work zone traffic control include the following:

- 1 **Safety.** Road user and worker safety must be an integral and high-priority element of every project.
- 2 **Roadway Geometrics.** The goal is to route road users through work zones using roadway geometrics, roadside features, and temporary traffic control devices as nearly as possible comparable to those for normal highway situations.
- 3 **Temporary Traffic Control Plan.** A temporary traffic control plan must be prepared and understood by all responsible parties before the site is occupied. Changes should be approved by an official knowledgeable in proper temporary traffic control practices.
- 4 **Inhibit Traffic as Little as Possible.**
  - a. Avoid speed reductions unless there is a definite justification.
  - b. Avoid frequent and abrupt changes in geometrics.
  - c. Devote special attention to high speed, high volume roadways.
  - d. Encourage the use of alternative routes.
  - e. Provide reasonable safe passage for pedestrians and cyclists.
  - f. Consider off-peak hours, e.g., night work.
  - g. Coordinate with local agencies.
- 5 **Clear and Positive Guidance.**
  - a. Provide adequate warning to guide road users.
  - b. Remove inconsistent traffic control devices.
  - c. Provide positive guidance through the use of flaggers.
- 6 **Night and Day Inspections.**
  - a. Utilize individuals trained or certified in work zone traffic control.
  - b. Assign a responsible person to have authority to stop work on the project.
  - c. Perform inspections, both day and night, to ensure effectiveness and compatibility with the traffic control plan.
  - d. Investigate all collisions in the work zone.
- 7 **Maintain Roadside Safety.**
  - a. Provide an unencumbered recovery area or clear zone.
  - b. Reroute road users using crashworthy devices, signs, and pavement markings.
  - c. Provide storage of equipment and material outside the clear zone.

**8 Maintain Good Public Relations.**

- a. Utilize a variety of media.
- b. Involve the adjacent property owners.
- c. Coordinate with police, fire, and medical agencies.
- d. Involve affected railroads and light rail companies.

**D. Temporary Traffic Control Elements**

**1 Traffic Control Plans (TCPs).**

"A temporary traffic control plan describes temporary traffic control measures to be used for facilitating road users through a work zone" (Ref. 1, Part VI). Temporary traffic control plans (TCPs) vary from very detailed to referencing typical drawings in the *MUTCD*. TCPs must be prepared by knowledgeable persons.

**2 Work Zone Components.**

Four areas (Fig. 26-1; Ref. 1):

- a. *Advance Warning Area*. Section of roadway where road users are informed through signing of upcoming work zone. There can be a single sign or a series of signs. Sign spacing can vary from 30 m in low speed urban situations to 800 m on freeways and expressways.
- b. *Transition Area*. Road users are taken out of their normal path using tapers formed from channelizing devices or pavement markings (Fig. 26-2, Ref. 1).

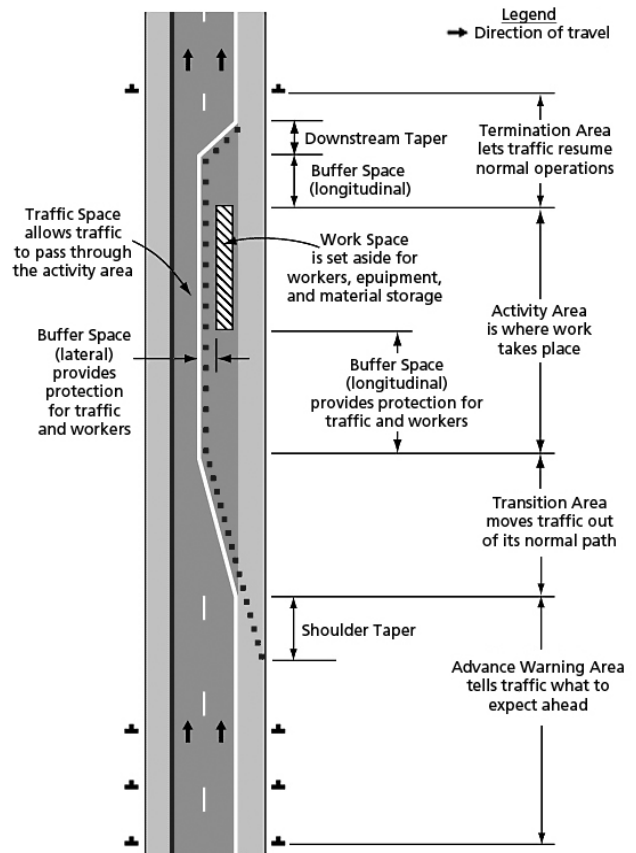

**Fig. 26-1 — Work Zone Components**

- *Tapers*. The following formulas are used to determine taper lengths; they are dependent on the speed of traffic and the width of lane.

For speeds  $\geq 70$  km/h:

$$L = WS$$

For speeds  $\geq 60$  km/h:

$$L = W^2/60$$

Where  $L$  is Length of merge taper (in m)

$W$  is Width of the transition; normally the width of a lane (in m)

$S$  is Speed limit, off-peak 85<sup>th</sup> percentile speed, or operating speed (in km/h)

- *Merging Taper*. The  $L$  from the formulas. The longest distance due to the nature of the merging maneuvers.
- *Shifting Taper*. A shifting taper is used when a lateral shift is needed. The length of a shifting taper is  $\frac{1}{2} L$ . Some state agencies use the merge taper distance for shifting tapers on freeways.

- *Shoulder Taper.* May be beneficial on high speed facilities where road users may use the shoulders to circumvent the activity area. The length of a shifting taper is  $1/3 L$ .
- *Downstream Taper.* If used, the minimum length of a downstream taper is 30 m per lane.
- *One-Lane, Two-Way Taper.* Lane closure on a two-lane, two-way roadway with the length of 30 m maximum.
- *Activity Area.* The area where the work takes place includes longitudinal and traverse buffer spaces, the traffic space, and the work space.
- *Longitudinal Buffer Space.* In advance of the work space, based on the braking portion of stopping sight distances.
- *Transverse Buffer Space.* A separation from the open lane and the work area, determined through engineering judgment.

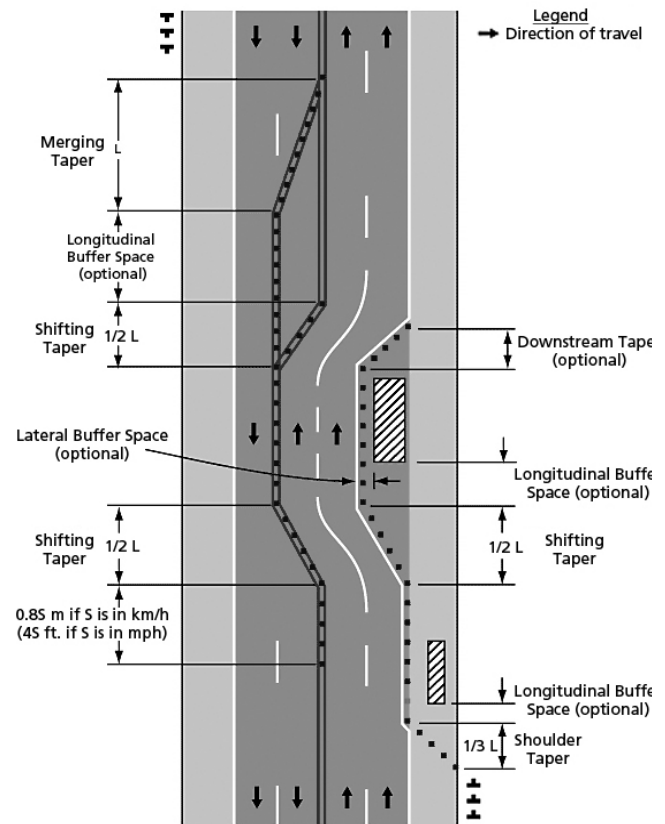

Fig. 26-2 — Types of Tapers

- *Traffic Space.* The lane(s) open to traffic around the work area.
- *Work space.* The area where the work is taking place.
- *Termination Area.* The area where road users can resume normal driving through the use of END OF ROAD WORK sign(s). There may be a need to post a speed limit sign due to laws enforcing DOUBLE THE FINES IN WORK ZONES signs.

- 3 **Speed Control in Work Zones** (see also E.2.d. below). Although excessive speed is not a commonly cited contributing factor for work zone crashes, workers in the zones believe that lower speed limits would enhance traffic safety. Many states specify lower statutory speed limits in these areas, while other states allow the highway agency to establish lower speed limits. Most states have increased the fines for speeding (some states, for all traffic violations) in work zones. Studies have found that achieving motorist compliance with work zone speed limits is difficult.

## E. Pedestrian and Worker Elements

- 1 **Pedestrians.** A wide range of pedestrians can be expected at work sites, including the young, old, and disabled (for example, hearing, eyesight, and mobility), for whom there needs to be a clearly delineated and usable travel path. Ref. 5 outlines inadequate practices for accommodating pedestrians in work zones.
- Training.* The various temporary traffic control provisions for pedestrian and worker safety shall be applied by knowledgeable (for example, trained or certified) persons after appropriate evaluation and engineering judgment.
  - Notification.* Advance notification of sidewalk closures must be provided.
  - ADA Compliance.* Adequate provisions should be made for persons with disabilities as determined by an engineering study.

- d. *Temporary Pedestrian Facilities.* Separate the pedestrian movements from both work activity and motor vehicle traffic to reduce conflicts with vehicles. The extent of pedestrian needs should be determined through engineering judgment for each work zone situation.
- 2 **Workers.** Consider the following key elements of temporary traffic control management for worker safety:
- a. *Training.* All workers should be trained on how to work next to motor vehicle traffic in a way that minimizes their vulnerability.
  - b. *Worker Clothing.* Workers close to the traveled way should wear bright, highly visible clothing per ANSI standards (Ref. 6).
  - c. *Temporary Traffic Barriers.* Temporary traffic barriers should be placed along the work space depending on factors such as lateral clearance of workers from adjacent traffic, speed of traffic, duration and type of operations, time of day, and volume of traffic.
  - d. *Speed Reduction.* Consider reducing the speed of motor vehicle traffic, mainly through regulatory speed zoning (see D.3. above), lane narrowing, lane reduction, police officers, or flaggers. Techniques to reduce vehicle speeds in work zones were investigated by the Midwest Smart Work Zone Deployment Initiative (MwSWZDI) in 1999. The use of changeable message signs, portable variable message signs, and lateral rumble strips were found effective in reducing speeds up to 8 km/h (5 mph) in work zones (Ref. 7). Positive results for speed reduction using speed display trailers and portable rumble strips were verified in Ref. 8.

## F. Types of Devices Used in Temporary Traffic Control

- 1 **Temporary Traffic Control Devices (TCDs).** Defined as all signs, signals, pavement markings, and other devices used to regulate, warn, or guide traffic, placed on, over, or adjacent to a street, highway, pedestrian facility, or bikeway by authority of a public body or official having jurisdiction.
- 2 **Color.** Where the color orange is required, fluorescent red-orange or fluorescent yellow-orange colors may also be used.
- 3 **General Characteristics of Signs.**
- a. *Color.* Black legend on an orange background, except for regulatory signs (3.f. below), the Railroad Advance Warning sign (W10-1, black legend and border on a yellow background), and crossing signs (fluorescent yellow-green backgrounds). Signs may be made of rigid or flexible material.
  - b. *Conspicuity.* May use standard orange flags or flashing warning lights positioned so as to not block the sign face.
  - c. *Nighttime.* All signs used at night must be either retroreflective or illuminated.
  - d. *Sign Placement.* Post-mounted signs usually mounted on the right side of the roadway. Mounting height for rural roads must be at least 1.5 m, measured from the bottom of the sign to the near edge of the traveled way; for urban areas at least 2.1 m above the edge of the traveled way.  
Temporary supports must be crashworthy and signs mounted on the supports at least 0.3 m above the traveled way.  
Neither portable nor permanent sign supports should be located on sidewalks, bicycle lanes, or areas designated for pedestrian or cycle traffic.
  - e. *Sign Maintenance.* Signs must be properly maintained for cleanliness, visibility, and correct positioning and replaced promptly when they have lost significant legibility.
  - f. *Regulatory Signs.* Must conform with the standards for permanent regulatory signs (see Chap. 14, Part C) and be authorized by the public agency or official having jurisdiction. Remove conflicting regulatory signs.

- g. *Warning Signs.* Must be diamond shaped with black legend and border on an orange background. The sign shape can modify the diamond shape to fit narrow mounting conditions. Remove conflicting warning signs.

#### 4 Portable Changeable Message Signs

- a. *Portable Changeable Message Signs (PCMs).* Temporary traffic control devices with the flexibility to display a variety of messages. A new chapter for PCMs is being developed in Part VI of the *MUTCD* from research presented in Dudek (Ref. 9).
- b. *Application.* Frequently used on high-density urban freeways, but have applications on all types of highways where alignment, re-routing, or other conditions require advance warning and information.
- c. *Components.* A message sign panel, control systems, power source, and mounting and transporting equipment.
- d. *Color.* Yellow or orange elements on a black background.
- e. *Placement.* On the shoulder of the road and mounted so that the bottom of the sign is 2.1 m above the roadway and visible from 0.8 km under both day and night conditions, with the message legible from a minimum distance of 200 m.
- f. *Operation.* Have the capability of adjusting brightness under varying light conditions. Used as a supplement to and not as a substitute for conventional signs and pavement markings.
- g. *Message Panel.* Either one or two phases, typically up to three lines of eight characters per line per phase. Display rates adjustable in order to be read twice by motorists traveling at the posted speed. Text shall not scroll or travel horizontally across the face of the sign. Should convey a single thought. The top line should present the problem, the middle line its location or distance ahead, and the bottom line the recommended driver action.

#### 5 Arrow Panels. An arrow panel is a sign with a matrix of elements that can emit either flashing or sequential displays to assist in merging and controlling road users through a work zone.

- a. *Types.* Type A used on low-speed, urban streets; Type B on intermediate-speed facilities, maintenance, or mobile operation; Type C on high-speed, high-volume facilities; Type D on authorized vehicles. Types A, B and C are rectangles; Type D has the shape of an arrow.
- b. *Color.* Elements shall be yellow with the panels in nonreflective black.
- c. *Placement.* Placed on shoulder of the roadway or, when shoulder is narrow, then in the closed lane. Mounted on a vehicle, a trailer, or other suitable support 2.1 m from the bottom of the sign to the roadway.
- d. *Operation.* Used with appropriate signs, channelizing devices, a barrier, or crash cushion. For nighttime use, elements have the capability of dimming by 50%.
- e. *Mode Selection.* An arrow panel must have three mode selections:
  - A flashing arrow, sequential arrow, or sequential chevron mode. For use on stationary or moving lane closures on multilane roadways.
  - A flashing double arrow mode.
  - A flashing caution mode. For shoulder work blocking the shoulder, work near the shoulder, or lane closure on a two-way, two-lane roadway.

#### 6 Channelizing Devices. These warn road users of conditions created by work activities in or near the roadway and guide them. They include cones, tubular markers, vertical panels, drums, barricades, lights, and directional arrow indicators. Warning lights are to be steady-burn in a series. Names and telephone numbers placed on channelizing devices must be non-retroreflective and not over 50 mm high. Damaged devices are to be replaced. Channelizing devices should be crashworthy (see Part I below).

- a. *Cones.* Ballast should be kept to a minimum.
  - *Color.* They must be orange.
  - *Types.* For speeds less than 70 km/h, 450 mm high; for speeds greater than 70 km/h or used at night, 700 mm high, with two 150-mm retroreflective bands.

- b. *Tubular markers.* Tubular markers may be used to 1) divide opposing lanes of road users, 2) divide motor vehicle traffic lanes when two or more lanes are kept open in the same direction, and 3) delineate the edge of a pavement drop off where space limitations do not allow the use of larger devices. Ballast should be kept to a minimum.
    - *Color.* Tubular markers must be orange.
    - *Types.* For speeds less than 70 km/h, 450 mm in height; for speeds greater than 70 km/h or used at night, 700 mm in height, with two 75-mm retroreflective bands.
  - c. *Vertical Panels.* Vertical panels are devices used to separate traffic in work zones.
    - *Color.* Panels have alternating white and orange retroreflective stripes, sloping downward at an angle of 45° in the direction traffic is to pass.
    - *Dimensions.* Panels are 200–450 mm wide and 600 mm high. The top of the panel is 900 mm above the roadway.
  - d. *Drums.* Drums are lightweight, deformable devices used to separate traffic in work zones.
    - *Color.* Drums are orange with a minimum of two alternating 100–150-mm wide, white and orange retroreflective stripes.
    - *Dimensions.* Diameter: 450 mm; height: 900 mm.
    - *Ballast.* Ballast is to be at the bottom and the drums are not to be filled with material or water. They must have closed tops.
  - e. *Barricades.* Portable or fixed devices having 1–3 rails, used to channelize traffic.
    - *Types.* Type I has one rail; to be used on conventional or urban streets. Type II has two rails; to be used on freeways or other high speed roadways. Type III has 3 rails; to be used for road closures.
    - *Color.* Rails are alternating white and orange retroreflective stripes, sloping downward at an angle of 45° in the direction traffic is to pass.
    - *Dimensions.* Rails are 200–300 mm wide and 600 mm high.
    - *Ballast.* Sandbags placed on the lower portion of the frame.
  - f. *Direction Indicator Barricades.* Portable devices having a rail and sign, used to channelize traffic.
    - *Color.* Rails are alternating white and orange retroreflective stripes, sloping downward at an angle of 45° in the direction traffic is to pass. Sign has a retroreflective black arrow on an orange background.
    - *Dimensions.* Rails are 600 mm wide and 200–300mm high. The sign is 600 mm wide and 300 mm high.
- 7 **Temporary Pavement Markings.** Those temporary markings that can be placed in work zones at the earliest possible date.
- a. *Dimensions.* Temporary pavement markings are 100 mm wide and 600 mm long in work zones.
  - b. *Application.* NO PASSING signs may be used instead of temporary markings for up to 3 calendar days (on low-volume roads for longer periods).
- 8 **Lighting.** Several types of lighting can be used in a work zone to supplement retroreflectorized signs, barriers, and channelizing devices, based on engineering judgment. They must be crashworthy.
- a. *Types of Warning Lights* (which can be mounted on channeling devices or signs).
    - *Type A Lights* are low-intensity flashing lights. Visible for 900 m, usually at night.
    - *Type B Lights* are high-intensity flashing lights. Visible during daylight for 300 m.
    - *Type C Lights* are low-intensity, steady-burn lights. Visible at night for 900 m.
  - b. *Other Types.*
    - *Floodlights* are used at night and must not present a disabling glare to motorists.



- *Flashing warning beacons* are a minimum diameter of 200 mm and supplement other temporary traffic control devices.
  - c. *Color.* Lights are yellow in color.
- 9 **Temporary Traffic Barriers.** Barriers are used to protect the workers and to channelize traffic through a work zone based on an engineering study.
- a. *Types.* There are three types of barrier.
    - *Concrete barriers* have significant mass and will deflect slightly upon impact. The "Jersey" type concrete barrier is the most commonly used.
    - *Water-filled barriers* have less mass and will deflect up to 7 m upon impact. Their use should be limited to low-speed facilities.
    - *Movable barriers* have significant mass and can be moved via a transfer vehicle up to 5.5 m laterally along the road.
  - b. *Color.* Barriers should be light in color.
  - c. *Crashworthiness.* Barriers should have some type of end treatment for crashworthiness.
  - d. *Application.* Concrete barriers can be used in merge tapers only on low-speed urban roads.

## G. Flagger Control

- 1 **Qualifications.** Flaggers should have the following minimum qualifications:
- a. Sense of responsibility for the safety of the public and the workers;
  - b. Adequate training in safe temporary traffic control practices;
  - c. Good physical condition, including sight, mobility, and hearing;
  - d. Mental alertness and the ability to react in an emergency;
  - e. Courteous but firm manner; and
  - f. Neat appearance.
- 2 **Clothing.** For daytime work, the flagger's vest, shirt, or jacket must be orange, yellow, yellow-green, or a fluorescent version of these colors. For nighttime work, outside garments must be retroreflective, orange, yellow, white, silver, yellow-green, or a fluorescent version of these colors that is visible for 300 m (Ref. 6).
- 3 **Hand-Signaling Devices.**
- a. *The STOP/SLOW paddle* is the primary and preferred hand-signaling device. Octagonal shape with a rigid handle, 450 mm wide with 150-mm letters. STOP face shall be red with white letters and border and the SLOW face orange with black letters and border. Both paddle faces to be retroreflectorized if used at night. Can be modified by incorporating white flashing lights for improved visibility and centered vertically or horizontally around the STOP legend.
  - b. *Flags.* Limit the use of flags to emergency situations. Flags are to be 600 mm square on a 900 mm staff. If used at night, flag to be retroreflectorized.
- 4 **Flagger Stations**
- a. *Location.* Far enough in advance of the work space so that approaching road users will have sufficient distance to stop before entering the work space.
  - b. *Distance.* To vary from 10 m at 30 km/h to 150 m at 105 km/h and can be modified due to grades.
  - c. *Signing Required.* Preceded by proper advance warning signs. At night, flagger stations should be illuminated.
  - d. *Single Flagger.* May be sufficient at spot lane closures where adequate sight distance is available.

## H. Types of Temporary Traffic Control Zone Activities

- 1 **Typical Applications.** Every work zone is unique. Many variables affect the needs of each work zone; e.g., location of work, road type, geometrics, vertical alignment, intersections, traffic volumes, vehicle mix, pedestrian volumes, speeds, and ADA requirements. The goal in work zones is safety with minimum disruption to traffic. The typical applications (TAs) of temporary traffic control zones are organized according to duration, location, type of work, and highway type. They may be altered to fit the conditions of a particular work zone. The TAs in the *MUTCD* have notes on the left page that apply to the drawing on the right page.
  - a. *Work Duration.* A major factor in the selection of devices to be used in work zones. There are five categories of work duration:
    - (1) *Long-term stationary* is work that occupies a location more than 3 days.
      - Install the full range of temporary traffic control procedures.
      - Retroreflectorized TCDs, if used at night.
      - Remove inappropriate markings and replace with temporary markings.
    - (2) *Intermediate-term stationary* is work that occupies a location more than one daylight period up to 3 days, or nighttime work lasting more than 1 hour.
      - Unfeasible to alter pavement markings, traffic barriers, or diversions.
      - Retroreflectorized TCDs, if used at night.
    - (3) *Short-term stationary* is daytime work that occupies a location for more than 1 hour, but less than 12 hours. Used for maintenance and utility operations.
    - (4) *Short duration* is work that occupies a location up to 1 hour.
      - Do not use fewer devices because the operation frequently changes location.
      - Use more dominant devices such as rotating or strobe lights on work vehicles.
    - (5) *Mobile* is work that moves intermittently or continuously. Activities such as litter pick-up, pothole patching, or utility operations.
      - Maintaining safe worker and road user conditions is a paramount goal.
      - Devices mounted on trucks might be necessary.
      - Do not use fewer devices because the operation frequently changes location.
      - Use shadow vehicles with an arrow panel for worker protection.
      - Move signs as work progresses.
      - Possibly use flaggers.
- 2 **Location of Work.** The closer the work is to the traveled lanes, the greater number of TCDs is needed. (In the discussion below, numbers in square brackets are the number of TAs for this situation in the *MUTCD*.)
  - a. *Work Outside of Shoulder.* When work is beyond, but within 4.5 m of the shoulder, little traffic control is needed. A single sign may suffice as the temporary traffic control.
  - b. *Work on the Shoulder with No Encroachment.* [3] Applies to short-term through long-term stationary operations. If 2.5 m or more of the paved shoulder is closed, at least one sign in the advance warning area and channelizing devices shall be used on a taper. For free-ways, two signs in the advance warning area should be used. Arrow panels, if used, operate only in the caution mode.
  - c. *Work on the Shoulder with Minor Encroachment.* [1] A minimum of 3.05-m (10-ft) lanes should be maintained, except that 2.75-m (9-ft) lanes may be used at low-speed, low-volume locations with no commercial vehicles.
  - d. *Work Within the Median.* Advance warning signs should be used if the work is within 4.5 m of the traveled way.
  - e. *Work Within the Traveled Way of Two-Lane Highways.* [4] Detour signs may be used to direct road users onto another road with appropriate DETOUR routing signs.

- f. *Work Within the Traveled Way of Urban Streets.* [9] Care must be given on how to control traffic, how many lanes should be open, prohibition of turning traffic, access to abutting properties, and pedestrian and bicycle activity. If pedestrians and bicyclists are affected, adequate temporary paths shall be provided.
- g. *Work Within the Traveled Way of Multilane, Nonaccess Controlled Highways.* [5] Work on two or more lanes in one direction is classified into right-lane closures, left-lane closures, interior-lane closures, multi-lane closures, five-lane closures. A merging taper must be used. In the *MUTCD*, three typical applications are for a left-lane closure and two for multi-lane closures.
- h. *Work Within the Traveled Way at an Intersection.* Work in the vicinity of intersections might block movements especially if there is a traffic signal present with left-turn signals and detection in each approach lane. Intersection work zones are classified as near side, far side, and within the intersection; that can create problems in more than one portion of intersection. Advance warning signs should be used on all legs of the intersection. Flagger(s) may be used to control traffic in an intersection. Intersections are signalized or unsignalized, and the appropriate highway agency should be contacted due to operational and capacity problems.
- *Near-side lane closure* [1] results in a reduction in capacity. Exclusive left-turn lanes may be utilized for through traffic.
  - *Far-side lane closure* [3] involves closing a lane on the far side of the intersection and appropriate lane closure on the near side, depending on amount of turning traffic on the near side.
- i. *Work Within the Traveled Way of Expressways and Freeways.* Work on these high-speed and high-volume facilities is complicated by the roadway design and operational features. Access to the work site could be a problem due controlled access. Special attention must be given to the traffic control devices used in a work zone due to the traffic volumes, the mix of traffic, and the speed of traffic. Most highway agencies perform work on freeways at night because of daytime congestion, and more devices should be used for night work. Some highway agencies perform maintenance work such as restriping pavement markings on weekends from dawn to 10 am. Temporary traffic control applications for freeways are as follows:
- Lane closure on a divided highway
  - Short duration and mobile operations
  - Lane(s) shift around a work space
  - Multiple lane closures
  - Interior lane closure

Six states had full closure of freeways for projects ranging from repaving to reconstruction, lasting from a weekend to 18 months. Lessons learned were that public outreach is important, as is the availability of alternate routes (Ref. 10).

Some agencies use contracting techniques such as cost-plus-time, lane rental, and incentives or disincentives to reduce amount of time associated with lane closures and minimize the impact on road users. Lane rental was the most effective (Ref. 11).

- j. *Two-Lane, Two-Way Traffic on One Roadway of a Normally Divided Highway.* [3] Two-lane, two-way operation on a freeway is a typical procedure that requires special treatment due to the potential of head-on collisions. The lanes of traffic must be separated with either temporary traffic barriers or channelizing devices. The use of signing and markings by themselves is insufficient. The operation normally uses a crossover and is covered in one of the typical applications in the *MUTCD*.
- k. *Interchanges.* [3] Access to interchange ramps on limited-access highways should be maintained even if the work space is in the lane adjacent to the ramps. Channelizing devices should clearly mark the access to exit ramps. If access can not be provided, then early coordination with agencies having jurisdiction of the cross streets should occur before the ramps are closed. The ramps should be closed using signs and Type III barricades.

- l. *Movable Barriers*. There is a TA using movable barriers on a freeway in the *MUTCD*.
- m. *Work in the Vicinity of Highway-Rail Grade Crossings*. [1] When there is a railroad grade crossing in the vicinity of a work zone, care should be taken to avoid a situation where vehicles can be stopped on the railroad tracks with no escape.

**I. Crashworthiness of TCDs (NCHRP Report 350)**

All TCDs used in work zones on the National Highway System must meet the requirements of National Cooperative Highway Research Project (NCHRP) Report 350 for crashworthiness. Crashworthy means that the devices will not cause injury to pedestrians, workers, and occupants of vehicles upon being struck. Some states have imposed the requirements on their entire state highway system. Table 26-2 lists categories of TCDs and compliance dates.

**J. Work at Nighttime**

Work activities on freeways are more prevalent at night due to congestion during daylight hours. Ref. 13 provides a structured decision process that encourages a systematic comparison of work performed during daytime v. nighttime. Guidelines were developed to aid in nighttime work zones (Ref. 14). Further guidelines were developed for illumination requirements (Ref. 15).

**K. Control of Traffic through Incident Areas**

An incident is a vehicle breakdown or collision, a natural disaster, or a special event. Preplanning for incidents should be an integral part of the design of the traffic control plan. If the occurrence lasts more than 3 days, the procedures and devices in Part VI of the *MUTCD* are to be used. The rerouting of large trucks can pose a problem during an incident. A new color, fluorescent pink, has been proposed in the 2003 *MUTCD* for incident management.

**Table 26-2 — NCHRP 350 Compliance Dates**

Category	Devices	Compliance dates
1	Cones, tubular markers, plastic drums, and delineator posts with no attachments (devices < 45kg).	January 1, 2000
2	Barricades, portable sign/stand units, intrusion alarms, vertical panels, and drums with lights (devices, 45kg).	Existing devices until December 31, 2007 New devices after October 1, 2000
3	Barriers, fixed sign supports, crash cushions, and TMAs.	October 1, 2000
4	Arrow boards, PCMS, portable traffic signals, and portable lighting units.	October 1, 2006

Source Ref. 12

**L. Simulation of Traffic in Work Zones**

Software programs have been developed to predict the traveler delay associated with work zones. The two most prevalent programs are QWERZ and QuickZone. QWERZ was developed by Texas A&M University and Quickzone by FHWA in cooperation with Mitretek Systems. The programs will predict the location and cause of delay to motorists in work zones.

**M. Useful Work Zone Websites**

- FHWA Work Zone Site; <http://ops.fhwa.dot.gov/wz>
- FHWA Best Practices in Work Zones; <http://www.ops.fhwa.dot.gov/wz/practices/practices.htm>
- FWHA ITS Work Zones; [http://www.its.dot.gov/Guide\\_files/frame\\_sec6\\_zones.htm](http://www.its.dot.gov/Guide_files/frame_sec6_zones.htm)
- FHWA Work Zone Safety; <http://safety.ops.fhwa.dot.gov/programs/wsz.htm>
- FHWA Work Zone Mobility; <http://ops.fhwa.dot.gov/wz/resources/publications.htm>
- National Work Zone Safety Information Clearinghouse; [www.safety.tamu.edu](http://www.safety.tamu.edu).

## N. Further Reading

For a more comprehensive treatment on work zones, see Ref. 16, Chap. 8, "Temporary Traffic Control."

### REFERENCES

1. U.S. Federal Highway Administration. *Manual of Uniform Traffic Control Devices for Street and Highways*, Washington, DC: 2003 Edition. <http://mutcd.fhwa.dot.gov>.
2. Keenan, Carol. "Work Zones that Work" *Public Roads*. v. 68, n.3., Nov/Dec 2004.
3. U.S. FHWA. Moving Ahead: The American Public Speaks on Roadways and Transportation in Communities. <http://www.fhwa.dot.gov/reports/movingahead.htm>.
4. U.S. FHWA. *Fatality Analysis Reporting System (FARS)*. Washington, DC: 2000. <http://fars.nhtsa.dot.gov>.
5. U.S. FHWA. *Work Zone Traffic Management Synthesis: Work Zone Pedestrian Protection*. Washington, DC: FHWA-TS-89-035, 1989.
6. *American National Standard for High-Visibility Safety Apparel (ANSI/ISEA 107-1999)*. 1999 Edition, ISEA - The Safety Equipment Association.
7. Pearce, D. P., M. J. Stuart, L. H. Tudor, and M. B. Bradley. *Interstate Evaluation of Products and Techniques to Reduce Speeding and Late Merging Tendencies of Motorist Entering Work Zones*. Transportation Research Board Annual Meeting, Washington, DC: 2004.
8. Carlson, P. J., M.D. Fontaine, and H. G. Hawkins. *Evaluation of Traffic Control Devices for Rural High-Speed Maintenance Work Zones*. Texas Transportation Institute, College Station, TX: 2000. Report 1879-1.
9. Dudek, C. L. *Developing Standards And Guidance For Changeable Message Signs In The Manual On Uniform Traffic Control Devices*. U.S.FHWA, Washington, DC: October 2003.
10. U.S. FHWA. *Full Road Closure for Work Zone Operations: A Cross-Cutting Study* (FHWA-OP-04-009) 2003. <http://www.ops.fhwa.dot.gov/wz/resources/publications/FullClosure/CrossCutting/its.htm>.
11. Transportation Research Board. *Reducing and Mitigating Impacts of Lane Occupancy During Construction and Maintenance*. National Cooperative Highway Research Program Synthesis 203, Washington, DC: 2000.
12. Rentz, H. H. "Crash Tested Work Zone Traffic Control Devices." *Informational Memorandum*, FHWA, Washington, DC: August 28th, 1998. [http://safety.fhwa.dot.gov/programs/road-side\\_hardware.htm](http://safety.fhwa.dot.gov/programs/road-side_hardware.htm).
13. Transportation Research Board. *A Procedure for Assessing and Planning Nighttime Highway Construction and Maintenance*. National Cooperative Highway Research Program Report 475, Washington, DC: 2002.
14. Transportation Research Board. *Guidelines for Design and Operation of Nighttime Traffic Control for Highway Maintenance and Construction*. National Cooperative Highway Research Program Report 476, Washington, DC: 2002.
15. Transportation Research Board. *Illumination Guidelines for Nighttime Highway*. National Cooperative Highway Research Program Report 478, Washington, DC: 2002.
16. Institute of Transportation Engineers. *Traffic Control Devices Handbook*. Washington, DC: 2001.

## A. Introduction

Off-street parking facilities range from the carport or garage in or near the home to multi-story garages near major traffic generators. In most residential areas they are a response to zoning requirements and home buyers' expectations. But in areas where demand exceeds on-street capacity, off-street parking becomes a necessity. The severity of the problem increases with the size of the trip generators, which include central business districts (CBDs), other shopping centers, educational campuses, medical centers, high-density residential areas, airports, transit stations, industrial sites, and entertainment and sports complexes.

In addition to off-street parking facilities, some land uses generate a need for terminals, which might more accurately be called transfer points since they primarily provide the opportunity for passengers or freight to move from one transport mode or route to another. These transfer points include airports, bus terminals, railroad stations, truck terminals, and some rapid transit stations. Large terminals of this type may also include retail establishments and other services.

## B. Need for and Location of Off-Street Parking

- 1 **Need.** In older cities, CBDs and outlying commercial districts developed without any provisions for off-street parking. Even in the horse and buggy and the Model T eras there was insufficient curb tethering or parking space to serve this traffic. Conditions deteriorated further as shoppers switched from public transit to private motor vehicles. By contrast, modern shopping centers supply ample off-street parking and thereby lure customers away from older retail areas.

In cities of less than 10,000 population, curb spaces may accommodate most motorists wishing to park in the CBD. In cities above that size, the supply of curb parking, as a percentage of the total available supply, ranges from 43% down to 14%. With increasing traffic flows, street space is needed for moving traffic, and parking must be entirely prohibited on many arterial streets. In large cities, similar problems also occur in commercial areas outside the CBD.

The same statements can be made about high-density residential areas, and for areas within acceptable walking distances of major traffic generators. Even if the use of curb space is optimized, demand eventually reaches a level at which additional space must be provided off-street. Parking studies, as outlined in Chap. 10, will determine the level of usage of existing parking spaces and the locations of supply deficiencies.

Where land use densities and trip generation rates are high enough to require off-street vehicle parking, there may also be a need to supply bicycle parking. See Chap. 21.

- 2 Facilities Provided in Compliance with Zoning Requirements.** Many city zoning ordinances require that off-street parking be provided when new buildings are constructed. However, there is a great diversity among cities' requirements for similar types of buildings. Some of the major building classifications and parking space requirements for more than 180 cities are shown in Table 27-1. Ref. 1 should be consulted for detailed requirements for these and other types of land uses and for off-street loading controls. Chap. 21 discusses the amount of bike parking that should be required in zoning ordinances for multi-unit residential, commercial, and institutional land uses.
- 3 Location.** Parking surveys usually reveal a shortage of parking spaces in core areas of older business districts, including CBDs, and near the focal point of other types of traffic generators. While it may not be economically feasible to provide additional facilities precisely where the greatest shortages exist, it is important to try to locate the parking supply close to where it is needed. This is especially true of facilities intended for short-term users (see Chap. 10 for information on distances walked and parking duration in CBDs). Peripheral ("fringe") parking facilities that require change in travel mode, e.g., from auto to bus, have been successful in a few cases, notably in Chicago, Cleveland, and Fort Worth, where large-capacity peripheral lots have good mass transit service to the respective CBDs. But, generally, drivers who are within one or two kilometers of their destination are unwilling to "park-and-ride" the last small part of their trips.

**Table 27-1—Zoning Requirements for Off-Street Parking**

Building Type	Range	Modal Value*
<i>Commercial and Industrial</i>		
<i>Spaces per 9.3 m<sup>2</sup></i>		
Office buildings, banks	0.08 - 1.33	0.25
Business and professional services	0.08 - 1.33	0.33
Commercial recreational facilities	0.16 - 2.00	1.00
Shopping goods - retail	0.06 - 3.00	0.50
Convenience goods - retail	0.10 - 1.33	0.50
Restaurants	0.06 - 2.00	1.00
Personal services and repairs	0.08 - 1.00	0.50
Manufacturing	0.08 - 1.00	0.20
Warehouses	0.02 - 0.67	0.10
Wholesale	0.03 - 1.33	0.15
<i>Residential</i>		
<i>Spaces per unit</i>		
Single family dwellings	0.50 - 3.00	1.00
Duplexes, multiple family dwellings	0.50 - 2.00	1.00
Apartment hotels, rooming houses	0.25 - 1.50	1.00
Hotels (spaces per bedroom)	0.16 - 2.00	1.00
Motels (spaces per bedroom)	0.25 - 1.25	1.00
<i>Public</i>		
<i>Spaces per 9.3 m<sup>2</sup></i>		
Museums, libraries	0.10 - 3.33	0.33
Public utilities	0.10 - 1.00	0.33
Welfare institutions	0.10 - 0.67	0.25
<i>Medical</i>		
<i>Spaces per 9.3 m<sup>2</sup></i>		
Medical and dental offices	0.08 - 1.33	0.50
Hospitals	0.10 - 2.00	1.00
Convalescent homes	0.08 - 1.00	0.50
<i>Auditoriums</i>		
<i>Spaces per seat</i>		
General auditoriums, theaters	0.06 - 0.33	0.25
Stadiums and arenas	0.05 - 0.33	0.25
School auditoriums	0.05 - 0.25	0.10
University auditoriums	0.06 - 0.25	0.10

Source: Ref.1.

\* - The value most often recommended for zoning ordinances.

## C. Financing (Refs. 2, 3)

- 1 **Source of Funds.** The following discussion covers financing both capital and operating costs; the former pay for constructing and equipping lots and garages, whereas the latter reflect the expense of running the facilities.
  - a. Parking, like any other service, must be paid for. The question of who should pay is often not easily answered because of conflicting attitudes concerning the service rendered and the beneficiaries. Some contend that parking is a part of highway transportation, for which space should be provided by the government, others that parking should be paid for by those who benefit. Beneficiaries include:
    - (1) The parkers, as immediate users of the facilities.
    - (2) The traffic generators who attract travelers into the area, and who benefit from their coming and staying there.
    - (3) The community, whose gains from business activities are many, including jobs, shopping opportunities, and tax revenues.
  - b. In practice, a variety of methods of financing off-street parking facilities has been developed which assign costs to specific beneficiaries or to a combination of them, and which span the spectrum from private capital to public financing.
- 2 **Private Financing.** Capital funds come from private sources in varied situations:
  - a. *Commercial Ventures.* The term refers to a business venture in which the sole purpose is to make a suitable profit by selling parking to the public; other automotive services may also be offered. In large cities, much off-street parking is provided in this way.
  - b. *Customer Facilities.* Commercial buildings, such as large stores, office buildings, medical centers, and banks often provide parking facilities for customers and clients. Facilities may be open to the general public, but operated to favor customers or clients. Parking may be either free or for a fee; in retail districts, customers are often given at least one hour of free parking. Almost all outlying shopping centers and supermarkets furnish customer parking at no charge.
 

Stores not large enough to provide their own parking facilities sometimes either form merchants' associations to build facilities or arrange with nearby commercial operators to accept their customers. Validation plans are often employed in the operation of facilities provided by merchants' associations. A store will pay for its customers in accordance with a prearranged schedule of fees. Some stores validate parking claim tickets whether or not a purchase is made, while others require a minimum purchase.
  - c. *Tenants' Facilities.* These are similar to customer facilities, but differ in that their use is restricted to residential or commercial tenants. Space is rented on a monthly basis or the charge is included in the tenants' rents.
- 3 **Public Financing.** Publicly owned facilities can be financed by the following methods:
  - a. *Current budget expenditures.* Except for small projects, this method is not feasible for most local governments because of financial stringencies.
  - b. *General obligation bonds.* Bonds secured solely by the faith and credit of the local government are seldom feasible either because of debt limitations and because parking is a lower priority than other projects that may be eligible.
  - c. *Revenue bonds.* These are secured by the revenue from parking facilities—either from those to be constructed by the bonds being issued or from all publicly-owned facilities under the government's jurisdiction. Because of this feature, they carry higher interest rates and require higher debt service reserves. They may be difficult to market.
  - d. *Guaranteed revenue bonds.* These bonds are also serviced by net parking revenues, but the municipality's faith and credit is pledged as a backup. Hence, interest rates tend to be lower.



- e. *Special assessment districts.* Assessment districts can be formed, and bonds can be secured by the taxes pledged within the designated district. Property owners within a district can also pay a tax to reduce financing costs in order to provide free or reduced-price parking.
- c. *Tax increment* bonds are similar, except that the tax revenues generated by incremental increases in assessments are pledged. Marketing these bonds requires assuring investors that properties within the special assessment district will indeed increase in value and, hence, in assessment and tax payments.
- f. *Project financing.* Off-street parking at airports and transit stations is commonly financed as a part of the total project. How much users are charged (if at all) is a matter of total project revenue needs, policy considerations, and competition from nearby parking providers.

#### 4 Public-Private Cooperation.

- a. *Municipal encouragement.* Some cities encourage the development of private parking by providing information, conducting parking surveys, furnishing technical advice, and possibly tax incentives, or even low-interest loans.
- b. *Non-profit corporations.* These are sometimes created to invest in facilities on city-owned land. In California, bonds issued under these circumstances are tax-exempt. Each facility must be financially self-sustaining. After the bonds are paid off, the facility becomes the property of the municipality, and may thereafter be operated either by the city or leased to a private operator.

### D. Shopping Center Parking

The amount of parking needed for a shopping center varies with its size and location. According to the Urban Land Institute (Ref. 3), 4.3 to 5.4 car spaces per 100 m<sup>2</sup> of gross leasable area provide enough parking for most situations where there is little walk-in trade or public transit. Additional analysis of shopping center parking is contained in Ref. 4.

### E. Airport Parking and Loading

As transfer points between air transport and ground transportation systems, airports require extensive parking and loading facilities.

#### 1 **Parking.** Airport parking characteristics are quite different from those of other areas.

- a. Facilities are very large. Hence the scale at which facilities must be planned is much larger than elsewhere. For example, San Francisco, which is the median size for large hub airports, as of mid-2005 has 10,000 spaces, and Dallas-Forth Worth has 39,800 spaces (Ref. 5). Pearson Airport in Toronto has 12,300 spaces in a single structure (Ref. 6). Airport parking facilities also produce more revenue per space per annum than needed to pay capital and operating costs.
- b. Even if land is available to develop such large facilities on one level (as lots), walking distances soon become excessive, especially when the need to carry baggage is considered. The maximum walk should be kept to less than 300 m. Multilevel garages are therefore needed at large airports, and the use of moving belts to reduce walking may be advisable. Off-airport lots served by shuttle buses or automated guideway systems become essential in the largest airport complexes. These off-airport lots are priced to attract long-term patrons, while garages and lots within walking distances of the terminals often have fee schedules that discourage long stays.
- c. About 75% of all parkers stay for fewer than 2 h, but perhaps 15% of vehicles are parked for 12 h or longer (Ref. 6). Parking demand is comprised of three components:
  - (1) Short-term parking by drivers seeing off or meeting passengers, or conducting business at the airport. The demand is influenced by how strictly short-term waiting is controlled in front of terminal buildings.

- (2) Long-term (longer than 6 h) parking by air travelers. This group is smaller numerically, but often accounts for the largest number of space-hours occupied. Total accumulation depends, among other factors, on the quality of service by other ground access modes, and on the degree of competition from privately-owned off-airport parking facilities.

Travelers who are at the non-home end of their trips, if not met or seen off by others driving to the airport, will not add to the public parking facility demand, although they may add to the space requirement for storing rental cars.

- (3) Rental car fleets, limousines, shuttle vans, charter buses, taxis, and airport and airline employees comprise another segment of parking space demand.

- d. Traffic patterns must allow for "triangular" movements from the access road to the terminal frontage for unloading and thence to the parking facility, and vice versa.

- 2 **Loading.** At the front of the terminal, space is required where drivers of cars, taxis, rental vehicles, shuttle vans, and buses may stop briefly. Because of post-9/11 security concerns, time limits are strictly enforced. Since the space along the frontage of these buildings is limited, extra loading surfaces are provided by parallel pedestrian islands and by double-deck ramps which connect with two stories of the terminal buildings. Loading for trucks servicing airport concessions and airline offices must be provided at the sides or underneath the buildings.

Air cargo loading, usually removed from the passenger area of airports, also requires careful design.

## F. Transit Station Parking and Loading

Some transit stations are designed to be accessed primarily by private automobiles, vans, buses, and bicycles, rather than by pedestrians. Large capacity parking lots and, increasingly, structures, space for stopping of autos and taxis to discharge or pick up passengers, and bus loading and unloading spaces are integrated into station design (Fig. 27-1). The spaces nearest the station entrance are assigned to passenger loading, parking for disabled persons, and short-term parking, those further removed to all-day parking. Specially-sized motorcycle spaces and bicycle parking lockers or racks may also be included.

## G. Parking Facility Design Considerations

- 1 **General.** The use of off-street parking facilities and the efficiency of their operations are in part determined by geometric design. The number and location of entrances and exits, stall sizes and layouts, aisle widths, surfacing, walkways, lighting, and—in multilevel garages—the number and location of ramps, stairs, and elevators are important considerations.

Geometric design must accommodate both the largest and smallest vehicles likely to use the facility; critical dimensions include length, width, height, front and rear overhang, roadway clearance, and minimum turning radii. For U.S.-manufactured automobiles these data are found in Ref. 8.

- 2 **Entrances and exits.** These should be located as far from street intersections as possible in order to minimize interference with street traffic. Poorly located and designed entrances and exits may make it difficult for a facility to be used to its full capacity. Exits should be designed to give leaving motorists adequate sight distance along the street being entered.
- 3 **Layout.** Stall dimensions, parking angles, and aisle widths are interrelated and depend on the size and shape of the area available and the kind of parking operation. Less space per vehicle is needed in facilities with attendant parking than in those where users park their own vehicles. Fig. 27-2 shows dimensions based on a 5.5 x 2.7 m stall for self-parking used for many years. Ref. 4 recommends using large sections of 5.2 x 2.6 m stalls in shopping centers in view of the preponderance of compact and subcompact vehicles. Narrower aisle widths (e.g., 3.5

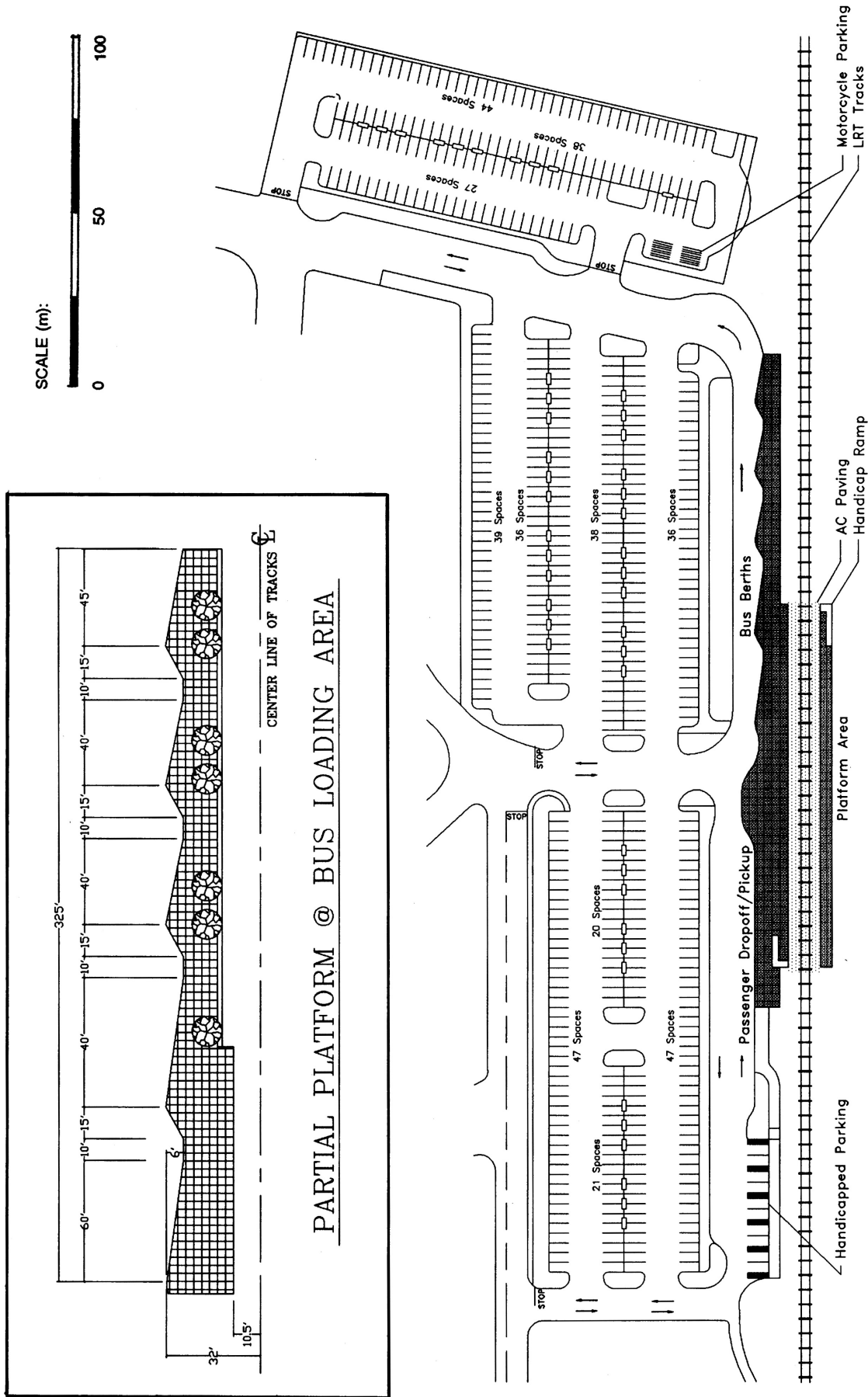

Fig. 27-1- Parking and Loading Facilities at a Light Rail Transit Station.

Source: California Department of Transportation and Sacramento Transit Development Agency

m for 60° parking and 3 m for 45° parking) are also suggested. However, the popularity of vans and utility vehicles for personal use suggests that smaller dimensions may not be adequate in the future. Aisles should be arranged for circulation within the parking area. For angle parking, the best arrangement is a series of one-way aisles that alternate in direction.

- 4 **Spaces for Disabled Persons** (Ref. 9). Federal regulations require the provision of the following number of parking spaces for vehicles of disabled persons in self-parking facilities:

**Table 27-2—Space Requirements for Vehicles of Disabled Persons**

Total Spaces in Facility	Minimum Number of Accessible Spaces	Total Spaces in Facility	Minimum Number of Accessible Spaces
≤ 25	1	201 - 300	7
26 - 50	2	301 - 400	8
51 - 75	3	401 - 500	9
76 - 100	4	501 - 1000	2% of total spaces
101 - 150	5	>1000	20 + 1% of total spaces over 1000
151 - 200	6		

Federal standards require spaces for the disabled to be 3,970 mm wide (2,440-mm stall plus a 1,530-mm access aisle) to permit easy handling of wheelchairs into and out of cars or vans; one access aisle may serve two abutting spaces. At least one in every eight spaces shall be served by an access aisle 2,440 mm wide to accommodate van parking. These spaces should be located near an elevator or pedestrian entrance to the facility.

If a facility is designed for valet parking, no special spaces (except as mentioned below) for the disabled are required, but a passenger loading zone with a 1,525-mm wide access aisle must be provided at the point where drivers hand over and receive their vehicles. However, some vehicles of disabled drivers have been fitted with specialized controls which valets are unable to operate; therefore, the guidelines recommend provision of a few self-parking spaces for these vehicles even in valet-parking facilities.

- 5 **Reservoir space.** Ample reservoir space at the entrances needs to be provided in facilities with attendant parking. Some queueing space is also required at busy entrances where ticket dispensers are used, and upstream of exits where payment is made.

## H. Types of Parking Garages (See Refs. 10 - 12 for detailed information)

Garages may be separate aboveground or underground structures, or may be an integral part of a larger building. They are classified by type of interfloor travel as ramp, sloping floor, or elevator garages, or by their method of operation as attendant parking or self parking.

- 1 The method of operation—attendant or self parking—is a very significant factor influencing interior design. The present trend in both lots and garages is to provide for self parking. High labor costs tend to make attendant parking unprofitable except where land costs are extremely high, and the hiring of attendants can be justified on the basis of more effective space utilization.
- 2 The area and dimensions of a site often dictate both the type and the capacity of a garage. Elevator or mechanical garages are usually built where parking demand is greatest, land costs are very high, or the area of the site is too small for a ramp or sloping floor garage.
- 3 Ramp types may be classified as curved or straight. (Included in this type is the sloping floor, which is actually a continuous ramp.) In curved ramps, the turns are usually made either half-circle or full-circle. In straight ramps, turning movements are made on the garage floors.
- 4 There is no one best garage type or ramp system. Selection of the type to be used depends not only on the dimensions of the site, but also on the street traffic pattern, topography, needed or desired capacity, type of patronage expected, and various economic considerations. See Figs. 27-3 through 27-6 for typical floor layouts of ramp type garages.

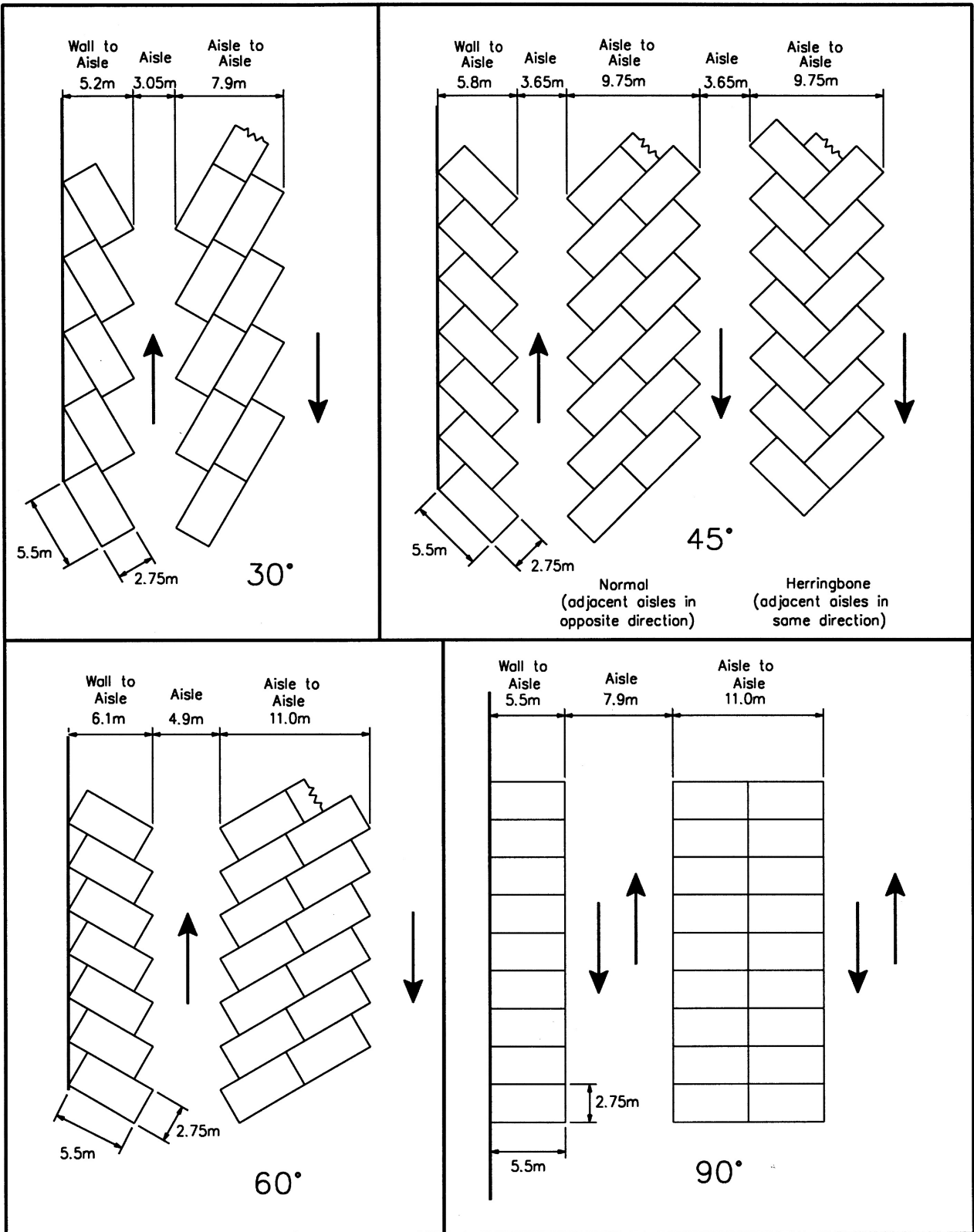

Fig. 27-2- Aisle and Stall Dimensions for Various Parking Angles

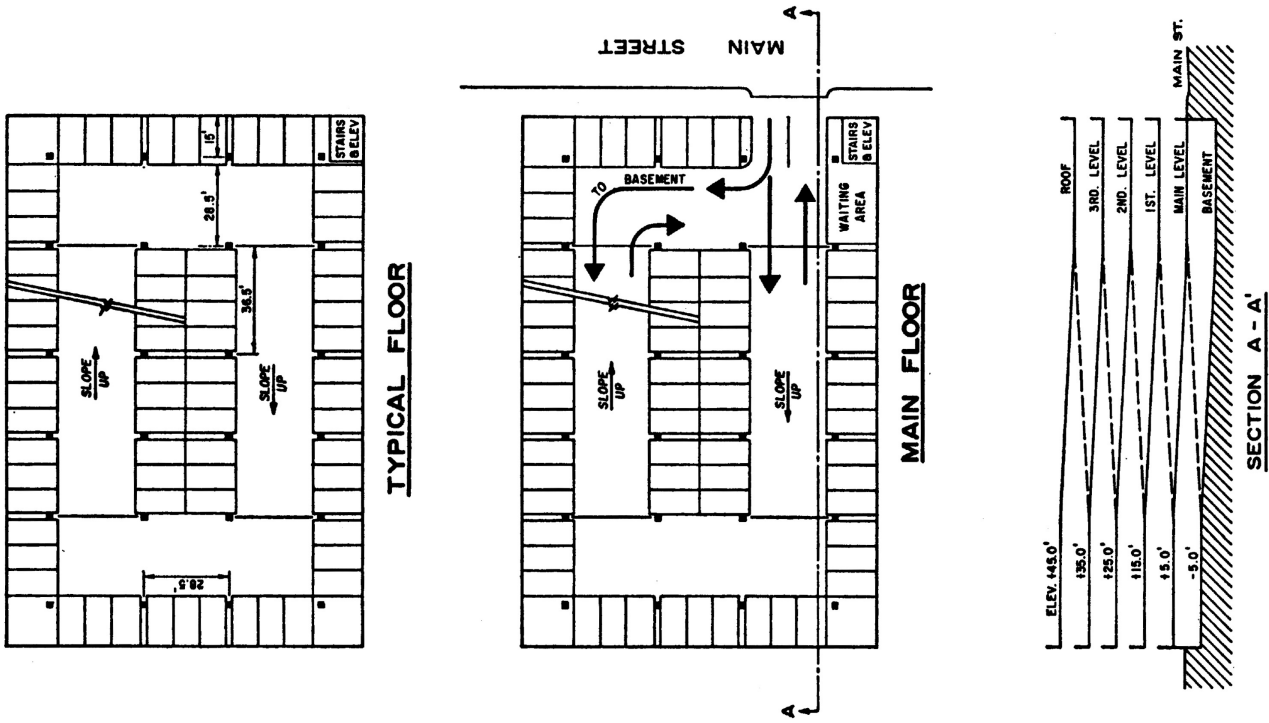

Fig. 27-6- Functional Plan: Sloping Floor Garage.

Source: Ref. 10

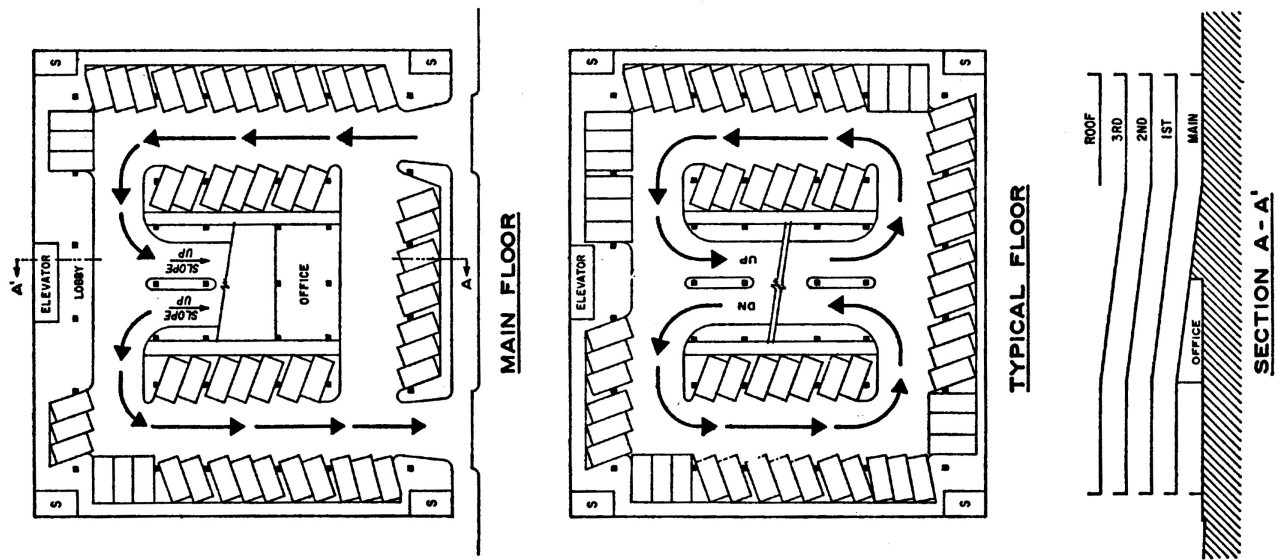

Fig. 27-5- Functional Plan: Straight Ramp Garage.

Source: Ref. 10

- 5 Elevator or mechanical garages are of several types, but most of those constructed and in use are capable of moving a vehicle horizontally and vertically simultaneously to deposit it into a pre-selected vacant space. While the degree of automation varies somewhat with type, the parking and unparking maneuvers are completely mechanical and are achieved quickly. Control panels at the entrance show which spaces are open for use.

## I. Administration of Publicly Owned Off-Street Parking Facilities

- 1 Public facilities may be owned by the municipal government or by a special agency created for the purpose. The latter may be a municipal authority with its own board of directors.
- 2 Cities may operate their facilities through their engineering or public works department, lease them to commercial operators, or arrange for a commercial operator to provide professional management. In the last arrangement, a contract is awarded that guarantees the management firm a minimum fee and may also give it a fixed percentage of gross revenues.

## J. Fee Collection and Control of Entrances

In facilities in which fees are charged, they may be collected manually or mechanically.

- 1 Where attendants park and deliver cars in lots or garages, one or more of them usually collects the parking charge as the motorist leaves. The entry to the facility has been previously recorded by time-stamping a ticket which can be issued either manually or by a vehicle-actuated dispensing machine.
- 2 In self-parking facilities, fee collection may be by:
  - a. *Parking meters.* It is common practice to use parking meters enforced by city police or meter attendants on municipally-owned facilities.
  - b. *Coin-operated ticket dispensers.* These may be used either with or without control of entrances to the parking facility. In either case, after entering the facility the motorists deposit coins or currency in a machine which dispenses a receipt to be displayed on the vehicle dashboard. An attendant checks the facility occasionally to see that all parked vehicles have valid receipts.
  - c. *Collection at gates.* Admission to the facility is gained by inserting either money or a coded card in the control mechanism which raises the gate. A detector inside the gate closes it after the vehicle has entered. Where a facility's use is restricted, authorized users may be required to display a decal in the windshield or on a bumper. Vehicles can be prevented from entering via the exits by similar gates, which open and close when actuated by departing vehicles.
  - d. *Collection within the facility.* In large facilities where charges vary with the length of time parked, fees are usually collected at the end of the user's stay at a cashier's position within the facility. The cashier's receipt opens the exit gate.  
 An automated fee collection system dispenses tickets with a magnetic strip at the entrance gate. The ticket is coded with date and time of entry. Before returning to the car, the driver inserts the ticket in a cash-collection machine within the facility and pays the amount that is indicated after the machine has read the ticket. The ticket is returned to the driver and will open the exit gate if presented within a few minutes after the payment of the fee.
- 3 Entrance and exit control systems, which count in-and-out movements, keeping track of accumulation at any time, are useful in large lots or garages where open spaces are not visible from entrances. One system locks the ticket dispensers or entrance gates and switches on "FULL" signs when no empty spaces remain.

## K. Truck Terminals (Ref. 13).

Off-street facilities for trans-shipment of truck-hauled freight are required in large cities because of the pattern of the trucking industry. Over-the-road carriers of less-than-truckload freight generally do not deliver each consignment to the individual addressee, but transfer their cargo to smaller trucks. Pickup of small shipments is similarly handled by small trucks which must then pass these on to long-haul carriers. This transshipment usually takes place in truck terminals.

- 1 Minimum facilities for a truck terminal of this type must include bays for over-the-road and local trucks, a platform over which goods are moved between them, and covered space for short-term goods storage. Other components include parking for empty trailers, "ready" trailers (loaded and awaiting a tractor for departure), and tractors, fueling islands, maintenance shop, and a wash bay.
- 2 Private truck terminals have been built by trucking firms or public agencies. Publicly constructed terminals include two by the Port Authorities of New York and New Jersey (PANYNJ) in Manhattan and Newark, NJ. The Manhattan terminal of the PANYNJ, which cost \$9 million when constructed about 1950, is 305x50 m in size, has a capacity of 2,000 metric tons per day, and provides 144 truck berths. Long-distance trucks are on city streets for less than 1 km between the Holland Tunnel and the terminal. Maintenance, repair, parking and storage areas for trucks, a 10 t crane, cooperage, and special handling for valuable shipments are available.

## L. Bus Terminals

Off-street bus terminals range from small lots with an adjacent ticketing building for long-distance bus routes in small cities to very large terminal buildings in New York City and San Francisco.

Probably the largest bus terminal ever built is the one owned and operated by PANYNJ in midtown Manhattan. This facility is used by almost all commuter and long-distance bus lines entering Manhattan from the West. Direct overhead ramps and a below-grade roadway directly connecting with the Lincoln Tunnel make it possible for most buses to reach the terminal without having to use city streets. The original structure, opened in 1950, was enlarged in 1963 and again in 1982. The terminal is 23,200 m<sup>2</sup> in area and 9 levels in height. The long-distance and suburban bus levels handle 180,000 passengers on 6,500 bus movements on a typical weekday, or 57 million passengers on 2.1 million bus movements annually. The top three levels provide parking for 1,080 automobiles.

Geometric design of bus terminals is beyond the scope of this syllabus. However, note that dimensions of sawtooth bus loading berths are shown in the inset to Fig. 27-1, and those for in-line berths (whether at the curb or off-street) in Table 23-3 of Chap. 23.

### REFERENCES

1. Witheford, D.K. and G.E. Kanaan. *Zoning, Parking, and Traffic*. Saugatuck, CT: Eno Foundation for Transportation, 1972. 196 p.
2. Weant, R.A., and H.S. Levinson. *Parking*. Westport, CT: Eno Foundation for Transportation, 1990. 335p.
3. Urban Land Institute and National Parking Association. *The Dimension of Parking: Fourth Edition*. Washington, DC: 2000. 209 p.
4. International Council of Shopping Centers. *Shopping Center Parking. The Influence of Changing Car Sizes*. New York: 1984.
5. Communication from Keith Wilschetz, V.P., Planning, DFW Airport. Jan. 2005.



6. Rich, R.C. "The History of Airport Parking". *Parking Professional*. June 2004, pp. 20-23.
7. Institute of Transportation Engineers. *Airport User Traffic Characteristics for Ground Transportation Planning*. Arlington, VA: 1976. Informational Report. 56 p.
8. Motor Vehicle Manufacturers' Association. *Parking Dimensions*. Detroit, MI: Annual.
9. Williamson, D.S. and G.S. Marx. *ADA Parking Compliance Manual*. Fredericksburg, VA: Institutional & Municipal Parking Congress, 1993, v.p.
10. Whiteside, R.E. *Parking Garage Operation*. Saugatuck, CT: Eno Foundation for Highway Traffic Control, 1961.
11. Chrest, A.P. et al. *Parking Structures: Planning, Design, Construction, Maintenance, and Repair*. 2nd Ed. New York: Chapman & Hall, 1996.
12. Childs, M. *Parking Spaces*. New York: McGraw-Hill, 1999. 289 p.
13. Drake Sheahan/Stewart Dougall, Inc. *Effective Truck Terminal Planning and Operations*. Washington, DC: Operations Council of the American Trucking Associations, Inc. 1980, 131 p.

## A. Objectives

### 1 Traffic Engineering Objectives.

- a. Promoting safety at night by making the roadway visible to drivers, bicyclists, and pedestrians, especially where motor vehicles might experience conflicts with pedestrian and bicycle traffic.
- b. Improving traffic flow at night by illuminating the roadway area so that road users can easily identify roadway geometrics and obstructions and better judge opportunities for overtaking.
- c. Illuminate long underpasses and tunnels so that road users have adequate visibility for safe vehicle operation.

### 2 Other Objectives.

- a. Reduce street crimes after dark.
- b. Enhance commercial properties (especially retail ones) by making them attractive to evening shoppers and other users.
- c. Attract non-traditional funding sources because of these ancillary benefits.

## B. Definitions

### 1 Light Terms and Measurement Units. (For much more detail, see Ref. 1, Chaps. 1 and 2.)

- a. *Light*. Radiant energy that is capable of being perceived by the eye and producing a visual sensation. The visible portion of the electromagnetic spectrum extends from approximately 380 to 770 nanometers.
- b. *Luminous Flux* ( $\Phi$ ). The rate of emission of luminous energy from a light source in all directions.
  - *Lumen* ( $lm$ ). The unit of measurement of luminous flux, defined as the amount of flux emitted within a unit solid angle (one steradian) by a point source having a uniform luminous intensity of one candela. The total flux from this source is  $4\pi$  (=12.57) lm.
- c. *Luminous Intensity* ( $I$ ). The luminous flux per unit solid angle from a light source in a given direction. Candlepower is intensity expressed in candelas.
  - *Candela* ( $cd$ ). The unit of measurement of intensity. One candela equals one lumen per steradian.
- d. *Illuminance* ( $E$ ). The density of luminous flux incident on a surface; the quotient of the flux divided by the area of the surface, when the surface is uniformly illuminated.

• *Lux (lx)*. The unit of illuminance; the illuminance on a surface 1 m<sup>2</sup> in area on which there is a uniformly distributed flux of 1 lm, or the illuminance on a surface all points of which are at a distance of 1 m from a directionally uniform source of 1 cd.

$$1 \text{ lx} = 1 \text{ lm} / \text{m}^2 \quad [28.1]$$

The level of illuminance on a plane produced by a light source of intensity I at a distance d is calculated by the equation

$$E = \frac{1}{d^2} \times \cos \theta \quad [28.2]$$

where  $\theta$  is the angle between the direction of the incident light and the normal to the plane. When the direction is normal to the plane,  $\cos \theta = 1$ . This equation also states the inverse-square law, i.e., the illumination varies inversely with the square of the distance between the source and the plane.

- e. *Luminance (Photometric Brightness) (L)*. The luminous intensity of any surface in a given direction per unit of projected area of the surface as viewed from that direction. The term brightness usually refers to the intensity of sensation resulting from viewing surfaces or spaces from which light comes to the eye. The unit of luminance, cd/m<sup>2</sup>, is defined as the uniform luminance of a perfectly diffusing surface emitting or reflecting light at the rate of 1 lm/m, or as the average luminance of any surface emitting or reflecting light at that rate.
- f. *Reflectance (Φ)*. The ratio of the light flux reflected by a surface to the incident flux. In the case of roadways it is affected by the surface characteristics and the viewing angle.
- g. *Uniformity Ratio*. The ratio of average to minimum illuminance or luminance.
- h. *Visibility*. The quality or state of being perceivable by the eye. In roadway lighting it is usually defined in terms of the distance at which an object can just be perceived.

## 2 Equipment Terms.

- a. *Lamp*. The light source employed.
- b. *Efficacy, Luminous Efficacy*. The quotient of the total luminous flux delivered from a lamp to the total power input to the lamp; expressed in lumens per watt.
- c. *Ballast*. An electrical device that provides the necessary voltage, current, and wave form to start and operate an electrical discharge lamp. See paragraph D.2.
- d. *Luminaire*. A complete lighting unit, consisting of a light source together with the parts (reflector and/or refractor) used to distribute the light, a socket to support and position the light source, wiring terminals, and a housing. See Sec. E.
- e. *Light Loss Factor (LLF)*. The product of the reduction in light due to lamp lumen depreciation (LLD) and luminaire dirt depreciation (LDD), and to any other elements known to affect the luminaire's light output. LLD depends on both the type and size of the lamp to be used; the designer should refer to manufacturers' data for appropriate values. Depending on the ambient atmosphere and the air filtering capability of the luminaire, the LLD can vary from 0.70 to 0.85; see Fig. 28-1. A common value for the LLF (the combined effects of LLD and LDD) is 0.70; under poor maintenance conditions it can be 0.50 or less.
- f. *Lighting Standard*. The pole with or without bracket or mast arm used to support one or more luminaires.
- g. *Bracket or Mast Arm*. An attachment to a lighting standard or other structure used for the support of a luminaire.
- h. *Lighting Unit*. The complete assembly of a lighting standard, bracket(s) or mast arm(s), and luminaire(s).
- i. *Mounting Height (MH)*. The vertical distance between the roadway surface and the center of the apparent light source of the luminaire.
- j. *Spacing*. The distance between successive lighting units measured along the centerline of the roadway.

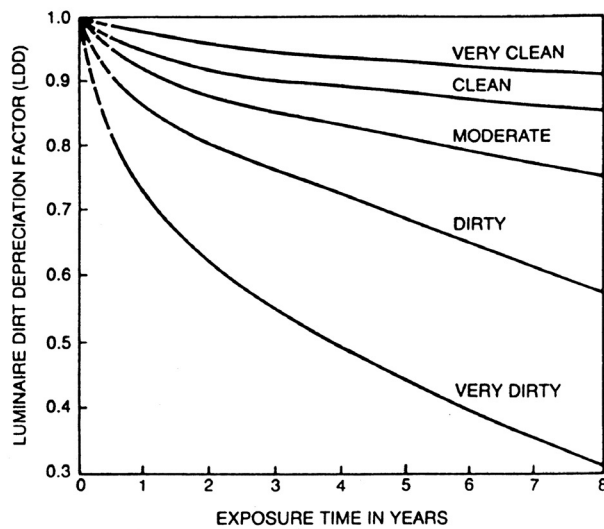

SELECT THE APPROPRIATE CURVE IN ACCORDANCE WITH THE TYPE OF AMBIENT AS DESCRIBED BY THE FOLLOWING EXAMPLES:

**VERY CLEAN**—No nearby smoke or dust generating activities and a low ambient contaminant level. Light traffic. Generally limited to residential or rural areas. The ambient particulate level is no more than 150 micrograms per cubic meter.

**CLEAN**—No nearby smoke or dust generating activities. Moderate to heavy traffic. The ambient particulate level is no more than 300 micrograms per cubic meter.

**MODERATE**—Moderate smoke or dust generating activities nearby. The ambient particulate level is no more than 600 micrograms per cubic meter.

**DIRTY**—Smoke or dust plumes generated by nearby activities may occasionally envelope the luminaires.

**VERY DIRTY**—As above but the luminaires are commonly enveloped by smoke or dust plumes.

**Fig. 28-1—Chart for Estimating Roadway Luminaire Dirt Depreciation for Enclosed and Gasketed Luminaires.**

Source: Ref. 2, used by permission.

## C. Fundamental Factors of Discernment

- 1 **Methods of Discernment.** A clear understanding of how one discerns an object on or near the roadway at night is necessary for designing an adequate lighting system.
  - a. *Contrast.* An important factor in discernment is the perceived difference between the luminance of an object and the luminance of the background—e.g., the roadway, the horizon. A tall object, such as a pedestrian, will often be perceived by both positive and negative contrast.
    - (1) Negative contrast (sometimes termed silhouette) occurs when the object luminance is less than that of the background.
    - (2) Positive contrast (sometimes termed reverse silhouette) occurs when the object is brighter than the background.
    - (3) Null contrast occurs when the luminance of an object and that of the background are equal or nearly so; this can result in the object appearing to vanish.
  - b. *Surface Detail.* When an object is seen due to variations in luminance or in color over its surface, without regard to its general contrast with its background, it is discerned by the surface detail. Such discernment depends on high direct illumination on the side facing the observer; it predominates in areas such as business districts and on high-volume thoroughfares.
  - c. *Glint.* When light falls on a specular surface, the reflection forms an image of the light source. Often the reflecting surface is not a plane, and the image may be distorted. The observer, unconsciously drawing on past experience, deduces the presence and nature of the object from which the light is reflected.
  - d. *Shadows.* An object, although invisible due to an equality of brightness between itself and its background, may cast a shadow. The shadow may present a contrast with the general brightness pattern, thus disclosing the presence of the object to the observer.
- 2 **Visibility.** Most aspects of traffic safety as related to roadway lighting involve visibility. The basic factors that influence visibility are:

- a. Luminance, size, shape, and texture of an object.
  - b. General brightness of the background of the roadway.
  - c. Contrast between an object and its surroundings.
  - d. Ratio of the pavement luminance to the surroundings as seen by the observer.
  - e. Time available for seeing.
  - f. Glare, especially from oncoming headlights.
  - g. Vision capability of the observer, especially as modified by age (see Chap. 3).
- 3 **Color.** Within the range of colors produced by various lamps used for roadway lighting there is no substantial effect on color perception.
- 4 **Glare** may be defined as any light, either direct or indirect, which reduces the ability to see or produces a sensation of ocular discomfort. Glare that reduces the ability to see is referred to as Disability Veiling Brightness (DVB); glare that causes only discomfort and no reduction in seeing ability is called Discomfort Glare.

While both forms of glare reactions are caused by the same light flux, the many factors involved in roadway lighting, such as source size, displacement angle of the source from the line of sight, illuminance at the eye, adaptation level, surround luminance, and exposure time and motion do not affect both forms in the same manner nor to the same degree. Only two factors, illuminance at the eye and displacement angle, are in general common to both forms.

5 **Limitations of Vehicle Headlights.**

- a. *Longitudinal.* In order to reduce the glare to oncoming vehicles, the distance to the point at which the beams of headlights hit the road—particularly for the lower beam—is limited. Even for modern headlights, this distance is such that the driver may not be able to stop for an object revealed by low headlight beams at speeds above 65 km/h.
- b. *Lateral.* Headlight beams are oriented generally forward and slightly to the right. On cars having dual headlights, the lamps providing the upper beam are aimed straight ahead, the lamps providing the lower beam slightly to the right. It is difficult to discern details outside the illuminated field and to discern clearly important objects such as the nose of a traffic island, point of divergence of a ramp from a freeway (start of taper), or bridge abutments.
- c. *Vertical.* Headlights distribute little light in an upward direction—e.g., toward overhead traffic control signs.

D. Roadway Lighting Lamps

- 1 **Lamps.** Four general types of lamps are presently in use for roadway lighting: incandescent, fluorescent, high-intensity discharge (HID), and low-pressure sodium (LPS). Characteristics for each of these types is shown in Table 28-1.

**Table 28-1—Roadway Lighting Lamp Characteristics**

Type of Lamp	Initial Light Output lm x 10 <sup>3</sup>	Approximate Efficacy lm/W	Approximate Lamp Life† h x 10 <sup>3</sup>
Incandescent	0.6 - 15	9.7 - 17.4	2 - 6
Fluorescent‡	6.8 - 14	61 - 72*	10
Clear Mercury	3.7 - 57	37 - 57*	18 - 28
Phosphor-coated Mercury	4.0 - 63	40 - 63*	18 - 28
Metal Halide	34 - 100	85 - 100*	10 - 20
High-Pressure Sodium	9.5 - 140	95 - 140*	15 - 28
Low-Pressure Sodium	1.8 - 33	100 - 183*	10 - 18

† Number of hours for a group of lamps at which 50 percent will remain in operation; based on 10 hours of operation per start (except 3 hours per start for fluorescent lamps).

‡ See paragraph D.1.b. for limitations on use.

\* These values exclude wattage losses due to ballast.

- a. The *incandescent or filament lamp* was the most commonly used for many years. It was inexpensive, simple, and easy to install. It produced pleasing color rendition and its small size permitted good light control with a reasonably sized fixture. However, its low efficacy and short rated life have made it undesirable for new installations.
- b. The *fluorescent lamp* is no longer used for new roadway lighting installations, but is still utilized for tunnel and sign lighting. Its large size makes it difficult to obtain good light control in a reasonably sized luminaire. The fluorescent lamp requires a ballast and its light output is affected by low temperature more than other lamps. Its one advantage is the broad light patterns that it provides on wet streets.
- c. The *mercury lamp* replaced the incandescent lamp in popularity. The initial cost is higher and it requires a ballast, but its high efficacy and long life make it considerably more attractive than the incandescent lamp. The blue-white color of the clear lamp is generally acceptable, and the arc tube size provides a light source that is small enough to permit good light control. A phosphor-coated outer bulb, featuring both higher output and more pleasing color rendition, is also available. However, the light source is the size of the outer bulb, presenting a problem in light control.
- d. The *metal halide lamp* is a type of mercury lamp in which the arc tube contains, in addition to mercury, certain metal halides that improve both the efficacy and the color rendition without the use of a phosphor-coated bulb. The light source size is that of the arc tube, permitting good light control in the same fixture used for clear mercury lamps.
- e. The *high pressure sodium (HPS) lamp* is replacing the mercury lamp. It is characterized by a golden-white color light output. HPS lamps are normally operated with special ballasts that provide the necessary high voltage to start the lamp. Some of the newer HPS lamps include:
  - Improved color rendition.
  - Internal starting devices that operate with mercury or metal halide lamp ballasts.
  - Dual arc tube or "standby" lamps that provide light as soon as power is restored after a momentary power interruption and that, in addition, have a rated life of 40,000 hours.
- f. The *low pressure sodium (LPS) lamp* is characterized by a monochromatic bright yellow color light output. This lamp requires special ballasts and increases materially in size as the wattage increases; the 185-W lamp is 1120 mm long. This large size makes it difficult to obtain good light control in a reasonably sized fixture. For a long time the poor color rendition of the LPS lamp made it unpopular for use in other than industrial or security applications. However, the potential benefit of energy conservation produced by the high efficacy of the lamp has resulted in an increasing acceptance of LPS lamps for lighting both commercial and residential areas. Presently available LPS lamps also have outstanding lumen maintenance, having no drop in light output over life.

*Lumen depreciation*—the reduction in light output over the lamp's life—varies with the type and operating condition of the lamp. Only the series-circuit incandescent lamp and certain LPS lamps do not suffer from this phenomenon.

The lumen output of a mercury or metal halide lamp varies with its operating position, the normal horizontal position resulting in a lower value than the vertical operating position. The values given in manufacturers' catalogs are usually for the latter.

Both of these reducing factors must be considered when calculating the average maintained illumination (see Sec.G).

- 2 **Ballast.** A ballast is required for all HID, LPS, and fluorescent lamps. The ballast provides the proper starting and operating voltage and wave form and limits the operating current to the proper value; for certain types of fluorescent lamps it supplies the necessary cathode heater voltage. "Regulator" type ballasts, in addition, allow only a small change in input lamp wattage over a range of input voltages on multiple circuits. Ballasts are available for operation on multiple circuits of from 120 to 480 V and on 6.6 A series circuits. A ballast may be located in the luminaire housing, in the pole base, or in an underground pull box, the most popular location being in the luminaire housing.

### E. Luminaires

A luminaire is composed of a light source, a reflector, and usually a glass or plastic lens or refractor. The function of the reflector and refractor is to gather the light from the source, direct it toward the roadway, and shape it into a desired pattern on the roadway. Proper distribution of the light flux from the luminaire is an essential factor in good roadway lighting.

#### 1 Definitions of Light Distribution Terms.

- a. *Roadway Lines.* The system of coordinates on a roadway used to classify and analyze light distribution (Fig. 28-2). The lines parallel to the curb line or edge of traveled way are Longitudinal Roadway Lines (LRL); those perpendicular to the curb or traveled way are Transverse Roadway Lines (TRL). Together these lines form a rectangular grid that is dimensioned in multiples of the mounting height (MH) of the luminaire under consideration.

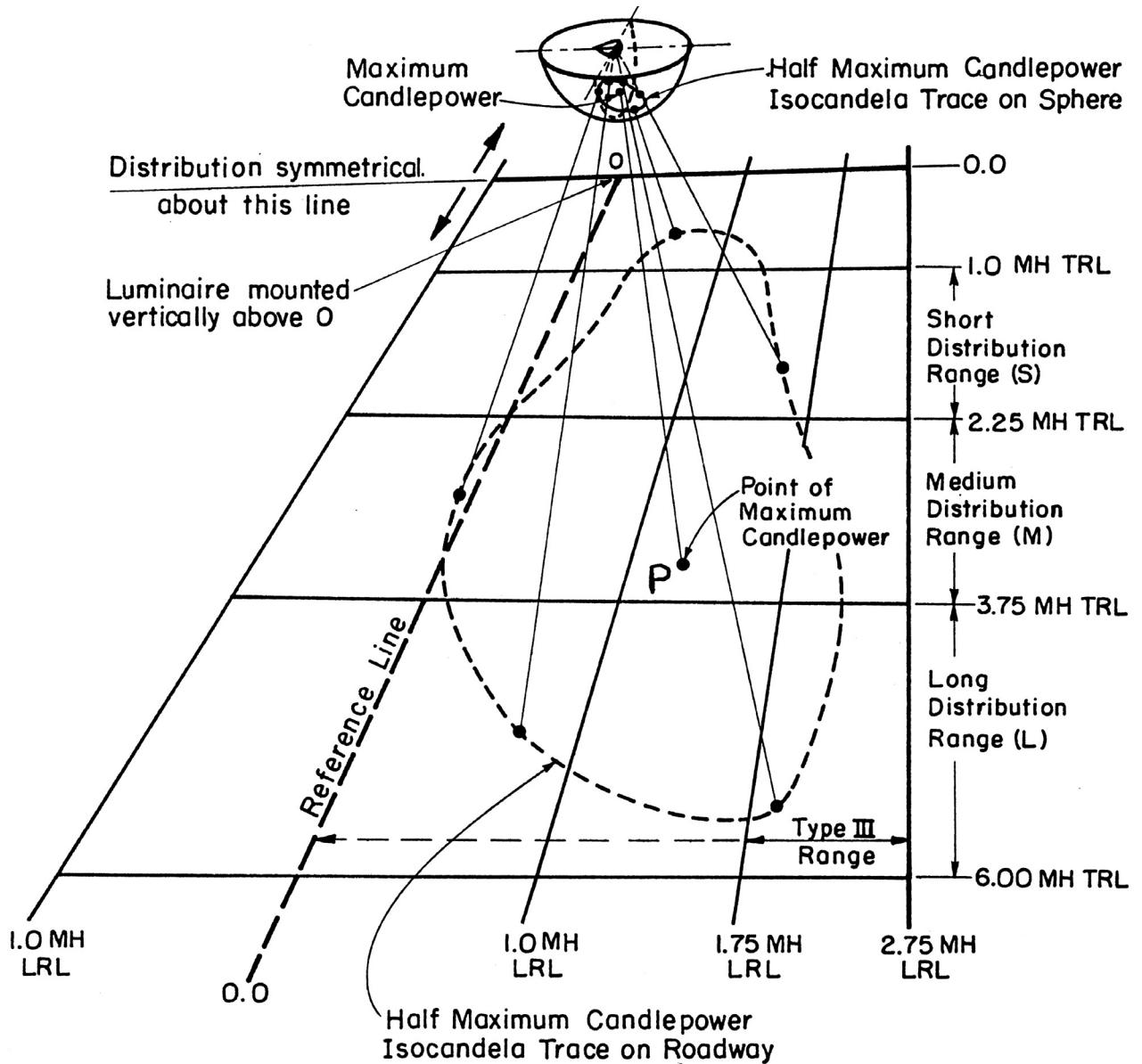
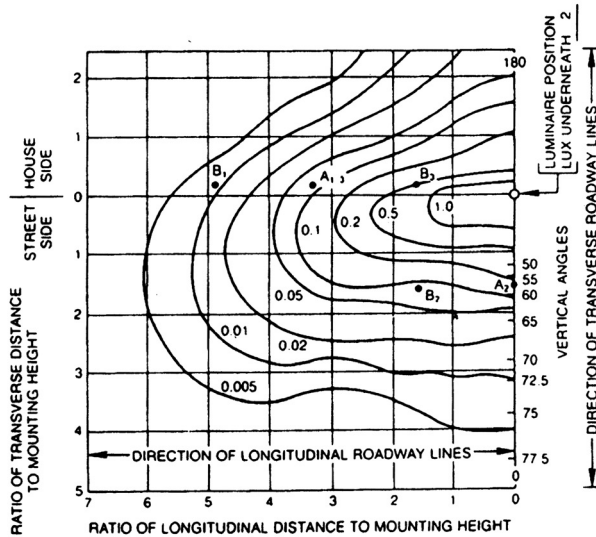

**Fig. 28-2—Classification System for Luminaire Distributions, based on Isocandela Diagram.**

The example of the trace shown is for a Type III Medium distribution

Adapted from Ref. 2 by permission of the Illuminating Engineering Society of North America.

- b. *Isocandela Diagram*. A series of lines plotted in appropriate coordinates to show directions in space about a source of light in which the candlepower is the same. Such diagrams are used to illustrate the luminous intensity distribution of a luminaire, including the point or points of maximum intensity. The projection of isocandela traces from a Luminaire to the plane of the roadway is shown in Fig. 28-2.
- c. *Isolux Diagram*. A diagram showing one or more lines or traces plotted to connect all the points on a surface where the illuminance is the same; a "contour map" showing the levels of illuminance on a surface. A typical isolux diagram is shown in Fig. 28-3.
- d. *Coefficient of Utilization (CU)*. The ratio of the luminous flux (lm) received on the surface of the roadway to the lumens emitted by the luminaire lamp(s) alone. It depends on the ratio of the roadway width to the mounting height and on the Luminaire light distribution. An example of coefficient of utilization curves is shown in Fig. 28-4.



**Fig. 28-3—Example of an Isolux Diagram of Horizontal Lux on Pavement Surfaces for a Luminaire Providing a Medium Semicutoff Type II Light Distribution (per 1000 initial lamp lumens); based on mounting height of 9 m.**

Source: Ref. 2; used with permission.

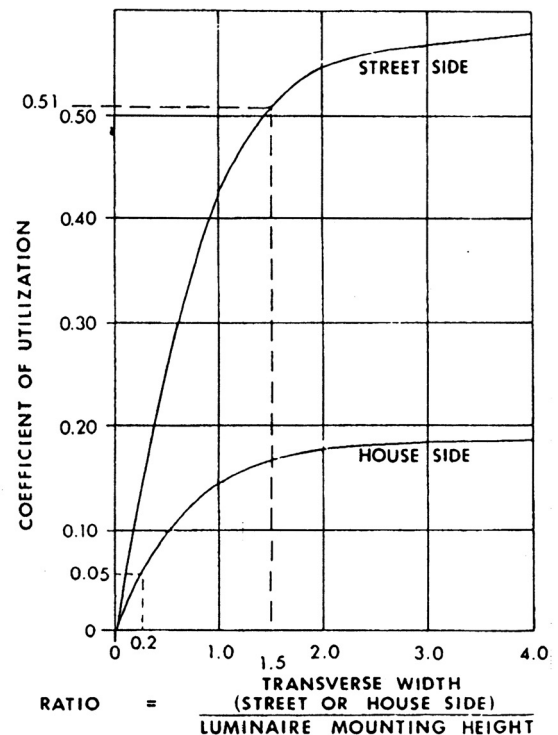

**Fig. 28-4—Example of Coefficient of Utilization Curves for Luminaire Providing Medium Semicutoff Type II Light Distribution.**

Source: Ref. 2; used with permission.

2 **Distribution Patterns.** All luminaire light distributions are classified according to their vertical and lateral distribution patterns and the light control in the upper portion of the beam. (See Tables 28-2, 28-3, and 28-4; also Ref. 2.) Glare shields may be added to reduce objectionable light emissions toward adjacent buildings or areas.

- a. *Vertical Distribution Pattern.* Different vertical distribution patterns longitudinal to the roadway are available for different spacing-to-mounting-height ratios. Where longer luminaire spacings are used, distributions with higher vertical angles of maximum candlepower emission are necessary in order to obtain the required uniformity of illuminance. Distributions with lower vertical angles may be used to reduce system glare, but require closer spacing of luminaires.



**Table 28-2—Vertical Distribution Patterns of Luminaires**

Vertical Distribution Class	Longitudinal Location of Maximum Candlepower Point on Pavement ("P" in Fig. 28-2)	Suggested Maximum Spacing
Short	1.00 - 2.25 MH	4.5 MH
Medium	2.25 - 3.75 MH	7.5 MH
Long	3.75 - 6.00 MH	12.0 MH

MH - Mounting Height.

Vertical distributions are classified as short, medium, or long, depending on the angle between the beam of maximum candlepower and the vertical, or the corresponding location of the point of maximum candlepower (P in Fig. 28-1) longitudinally along the roadway, measured in multiples of MH; the limits of each class are shown in Table 28-2.

- b. *Lateral Distribution Pattern.* Lateral light distributions are divided into two groups based on the location of the luminaire in relation to the area to be lighted. Types I and V are associated with luminaires mounted at or near the center of the lighted area, Types II, III, and IV with luminaires mounted near the side of the lighted area. Progressing from Type II to Type IV, the width of the light distribution increases while its length along the street decreases. In Type II distributions, all of the half-maximum candlepower isocandela trace lies on the luminaire side of 1.75 MH LRL, in Type III it crosses this LRL but lies within 2.75 MH laterally, and in Type IV it crosses over 2.75 MH LRL. Fig. 28-2 shows the plan view for different lateral distributions. Fig. 28-5 shows this trace for a Type III lateral, medium vertical distribution.

Types I and II luminaires are available in a "four-way" configuration for intersection illumination (Type I from the center, Type II from the corners) as well as in the conventional pattern for midblock and freeway use. Type V illuminates equally through 360°, and is appropriate for parking lots and general area lighting.

- c. *Distribution Control Above Maximum Candlepower (Cutoff).* Increases in the vertical angle of light flux emission result in a desirable increase in pavement brightness, but both disability and discomfort glare also increase. The respective rates of increase and decrease for these factors are not the same, and some design compromise may be necessary for a balanced system. Through luminaire design the candlepower in the portion of the beam emitted at more than 80° from the vertical can be controlled. This control is divided into four categories, defined by the proportion of total candlepower at higher angles as indicated in Table 28-3.

**Table 28-3—Light Control in Upper Portion of Luminaire Beams**

Cutoff Category	Candlepower at 90° above nadir	Candlepower at 80° above nadir
Full cutoff	0% of total	≤10% of total
Cutoff	≤2.5% of total	≤10% of total
Semicutoff	≤5% of total	≤20% of total
Noncutoff	No limit	No limit

- 3 **Poles.** Luminaires may be mounted on poles made of steel, aluminum, concrete, fiberglass, or wood. Ref. 4 states that breakaway or slip bases be used for poles that are:
- located less than 10 m from the traveled way and are not mounted on a structure,
  - installed adjacent to roadways where speeds are in excess of 65 km/h,
  - not protected by guardrail, and
  - not located where a pole knockdown would endanger pedestrians.

At signalized intersections, one pole may serve both for a luminaire and signal heads. Utility line poles are often used to mount luminaires in residential areas.

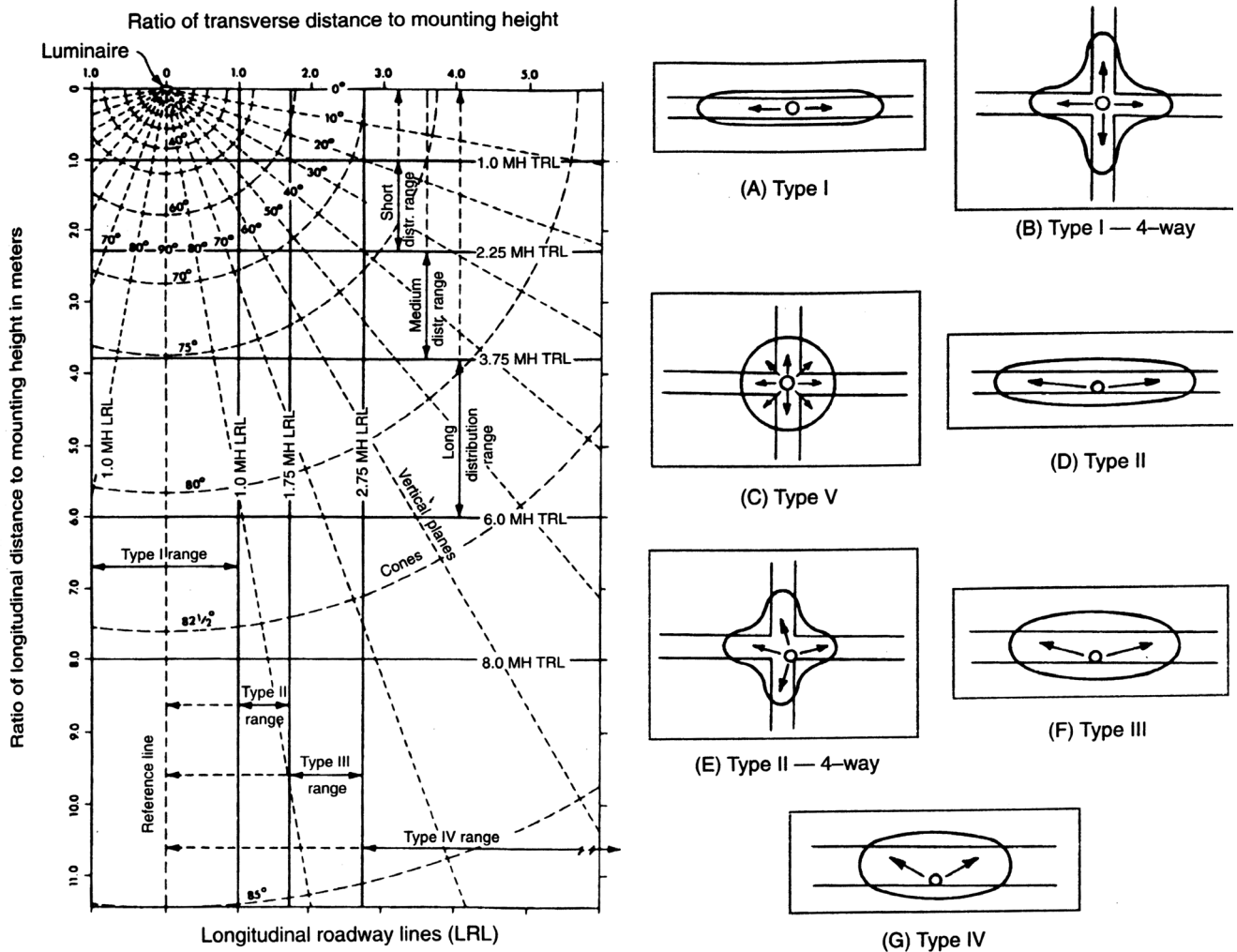

Fig. 28-5—Plan View of Roadway Coverage for Different Types of Luminaires

Source: Ref. 1, Fig. 22-6, by permission of the Illuminating Engineering Society of North America.

4 **Other Mountings.** Luminaires may also be mounted on bridge railings, from the walls of buildings, or from the soffits (ceilings, bottom surfaces) of tunnels and overpasses.

## F. Roadway Lighting Design

The basic goal of roadway lighting is to provide patterns and levels of horizontal pavement luminance and of horizontal and vertical illuminance of objects. Although the Illuminating Engineering Society of North America's (IESNA) publication RP-8 (Ref. 3), entitled "American National Standard Practice for Roadway Lighting," is a useful guide to planning, design, operation, and maintenance of roadway lighting systems, it is important for its users to recognize that it is strictly a guide.

Of particular importance is the following statement from the Foreword: "It [the Standard Practice] is neither intended as, nor does it establish, a legal standard for roadway lighting systems. Its purpose is to provide recommended practices for designing new roadway lighting systems, and it is not intended to be applied to existing lighting systems until such systems are redesigned." The important words here are **"nor does it establish a legal standard for roadway lighting systems."** Too often liability attorneys will ignore this disclaimer and claim that a public agency's failure to design lighting at a particular location to the design parameters included in RP-8 represent negligence on the agency's part. Public agencies should make their

attorneys aware of this disclaimer, should action concerning roadway lighting be taken against the agency. On the other hand, a public agency may by local ordinance adopt RP-8 as the design standard for roadway lighting installed, operated, and maintained by or for that agency. Such an ordinance should not be retroactive unless the agency is willing to update all existing lighting. And once the ordinance is adopted the agency must adhere to its requirements.

Users of RP-8 should be aware that it is oriented towards continuous roadway lighting and does not specifically address intersections or other points of localized lighting. Section 3.8, Traffic Conflict Areas, reads in part: "The values in Table 2, 'Recommended Maintained Luminance and Illuminance Values for Roadways,' are for roadway sections that are continuous and nearly level. Intersecting, merging, or diverging roadway areas may require special consideration. The lighting within these areas should be at least equal to the sum of the values recommended for each roadway that forms the intersection." In the instance of an intersection of streets that are not continuously lighted, it is necessary to refer to an agency's lighting ordinance or some other accepted standard. In California, that can be found in Sec. 9 of the *Traffic Manual* published by the California Department of Transportation (Caltrans) (Ref. 4). It sets forth minimum illuminance levels within crosswalk areas and at the intersection of the center lines of the intersecting streets. Incidentally, this is an example of a roadway lighting standard developed and adopted by a public agency without reference to RP-8.

- 1 **General.** A driver's eye discerns an object on or near the roadway due to contrast between the brightness of the object and the brightness of the background or pavement, or by means of surface detail, glint, or shadows (see Sec. C.).

Up to the 1983 standard, roadway lighting was designed on the basis of pavement illuminance — the amount of light or luminous flux falling on the pavement. The design elements were the level of illuminance (in lux) and the uniformity ratio. RP-8-1983 (Ref. 2) introduced a new design concept, that of luminance, and stated that either the illuminance or luminance method could be used for design. Pavement luminance is more realistic in that it considers the luminous flux (in  $\text{cd}/\text{m}^2$ ) reflected per unit of pavement surface in the direction of a standardized observer. It depends on the pavement surface characteristics, the light distribution from the luminaire(s), and the relative position of the luminaire(s), the observer, and the pavement surface.

The current RP-8-00 (Ref. 3) allows the use of both the illuminance and luminance design methods and also introduces the new concept of small target visibility (STV). STV permits an even more realistic consideration of the driving task, because it is based on the calculation of the visibility of a field of 180 x 180 mm targets located on an area of the pavement. It even considers the contrast between the target and the immediate background, the transient adaptation characteristics of the eye, and the visual capability of the driver. To consider all of these factors requires a rather complex computer program. RP-8-00 states: "The designer should be familiar with all of these [methods] in order to decide which one best addresses the needs of the particular project."

There are certain problems with the STV method. From the designer's point of view, an important one is that it will not directly consider the glare of oncoming headlights, because to date industry has been unable to put the photometric distribution of standard headlighting into a form that can be used in STV equations. A problem for the user is that no manufacturer has yet developed a roadway luminaire on the basis of STV. In addition, some critics point out that no real-life systems have been constructed to validate the concept, and that the computer program has yet to be validated independently.

Since both RP-8-1983 and RP-8-00 endorse the illuminance and the luminance design concepts, the following discussion will consider both in some detail. Due to its complexity, STV will be discussed only briefly. It should also be noted that RP-8-00 does not mention the luminaire light distribution classifications directly, because such classifications are not of any aid in selecting luminaires when designing using the STV criteria. Instead, RP-8-00 refers for such classifications to RP-8-1983, which therefore remains a valuable reference for the illuminance and luminance design methods.

- 2 **Design Using the Pavement Illuminance Method.** This method remains popular due primarily to its simplicity as compared to the luminance method. The level of illuminance, as stated above, is one element in roadway lighting design; it is also an expression of the quantity of roadway lighting. It is easily measured using a relatively simple instrument. Table 28-4 gives recommended levels of illuminance for various classifications of roadway and area, based on R2/R3 pavement classification.

**Table 28-4—Recommended Illuminance Values and Uniformity Ratios**

Road Classification	Minimum Average Maintained* Illuminance ( $E_{avg}$ ) - lx			Maximum Uniformity Ratio ( $E_{avg}$ to $E_{min}$ )
	Commercial Area	Intermediate † Area	Residential Area	
Freeway Class A‡	9	9	9	3 to 1
Freeway Class B‡	6	6	6	3 to 1
Expressway	14	12	9	3 to 1
Major	17	13	9	3 to 1
Collector	12	9	6	4 to 1
Local	9	7	4	6 to 1
Sidewalks (Roadside)	10	6	2	—

Source: Derived from Ref. 2, Table 2.

- \* Based on average (R2/R3) pavement classification (Table 28-7). These values represent the lowest in-service illuminance applying the expected Light Loss Factor (Para. B.2.e.).  
 † Areas with moderately heavy nighttime pedestrian activity.  
 ‡ Applies to both mainline and ramp roadways. Class A - high traffic volumes, visual complexity; Class B - all other freeways.

The design process involves selection of the type of lamp, type of luminaire and light distribution, mounting height, spacing, and output from each luminaire, which in combination will produce the desired lighting results. The calculation of the average horizontal illuminance produced by a lighting system is an iterative process, in which various combinations of the system components are assumed and their resultant illuminance is calculated. Appendix B of Ref. 2 gives information and examples of this computation process.

The relationship between horizontal illuminance and the various factors discussed is given by Eq. 28.3 which can also be solved for the rated lamp output or the spacing if a level of illuminance is specified.

$$E_{avg} = \frac{Lm_{rated} \times CU \times LLF}{spacing \times roadway\ width} \quad [28.3]$$

where:

$E_{avg}$  = the average horizontal illumination in lux (spacing and roadway width in meters).

$Lm_{rated}$  = the rated lamp output in lumens.

$CU$  = the Coefficient of Utilization for the luminaire to be used (see B.3.d. above).

$LLF$  = the Light Loss Factor for the luminaire to be used (see B.2.e. above).

**3 Design Using the Pavement Luminance Method** (Ref. 6). This method involves considerably more work since there is no simple formula for the average pavement luminance. Rather, individual luminances are calculated for each point on a grid on the roadway, using either manual/graphical means (Ref. 2, p. 26-32 or Ref. 6, p. 27-32), or a computer program (Ref. 6, p. 15-27).

Ref. 6 shows a method of luminance design in which the first step is the determination of a tentative or trial spacing using the illuminance design method to determine a desired average illuminance. This spacing and the other design parameters are then inserted into the formula, and the first luminance calculation is made. If the desired results are not obtained, the parameters are adjusted and another evaluation made. Table V of Ref. 6 indicates the effect of the changes in parameters such as luminaire location, lamp size, luminaire distribution, and luminaire arrangement on various luminance values. This iterative process is continued until the required results are obtained.

The *luminance level* can be measured using a more complex instrument that has the optical requirements necessary to examine a small area of pavement surface under specified viewing conditions.

Table 28-5 gives the recommended values of luminance and uniformity ratios. These values are the result of the calculation method previously described.

*Veiling luminance* ( $L_v$ ) is that luminance produced by bright sources or areas that results in decreased visual performance and visibility. The maximum veiling luminance for a particular luminaire is included as part of its photometric data.

**Table 28-5—Recommended Luminance Values and Uniformity Ratios**

Road Classification	Area Classification	Minimum Average Luminance $L_{avg}$ (cd/m <sup>2</sup> )	Maximum Luminance Uniformity Ratio		Maximum Veiling Luminance Ratio $L_v/L_{avg}$
			$L_{avg}/L_{min}$	$L_{max}/L_{min}$	
Freeway Class A*		0.6	3.5	6.0	0.3
Freeway Class B*		0.4	3.5	6.0	
Expressway	Commercial	1.0	3.0	5.0	
	Intermediate†	0.8	3.0	5.0	0.3
	Residential	0.6	3.5	6.0	
Major	Commercial	1.2	3.0	5.0	
	Intermediate†	0.9	3.0	5.0	0.3
	Residential	0.6	3.5	6.0	
Collector	Commercial	0.8	3.0	5.0	
	Intermediate†	0.6	3.5	5.0	0.4
	Residential	0.4	4.0	8.0	
Local	Commercial	0.6	6.0	10.0	
	Intermediate†	0.5	6.0	10.0	0.4
	Residential	0.3	6.0	10.0	

Source: Ref. 2.

\* Applies to both mainline and ramp roadways. Class A - high traffic volumes, visual complexity; Class B - all other freeways.

† Areas with moderately heavy nighttime pedestrian activity.

**4 Design Using the STV Method.** Like the luminance design method, the STV method is also an iterative process. A tentative design is developed and is inserted into a series of equations even more complex than that used with the luminance method. The final result is in terms of visibility level.

**5 Factors Common to All Methods.**

a. *Uniformity Ratios.* This is another element of roadway lighting design. Recommended maximum values are shown in Tables 28-4 and 28-5.

- b. *Pavement Classification.* The texture and color of each type of pavement determines its reflectance, which affects the luminance produced by a given level of lighting. Table 28-6 shows the four classifications of pavement for reflectance analysis. Complete determination of the recommended average maintained illuminance and luminance requires the application of these pavement classifications. The R2/R3 classification applies to most pavement surfaces.

**Table 28-6—Road Surface Classification**

Class	Q <sub>0</sub> *	Description	Mode of Reflectance
R1	0.10	Portland cement concrete road surface. Asphalt road surface with a minimum of 15% of the aggregates composed of artificial brightener (e.g., Synopal) aggregates (e.g., labradorite, quartzite).	Mostly diffuse
R2	0.07	Asphalt road surface with an aggregate composed of a minimum of 60% gravel (size greater than 10 mm). Asphalt road surface with 10 - 15% artificial brightener in aggregate mix (not normally used in North America).	Mixed (diffuse and specular)
R3	0.07	Asphalt road surface (regular and carpet seal) with dark aggregates (e.g., trap rock, blast furnace slag), rough texture after some months of use (typical highways).	Slightly specular
R4	0.08	Asphalt road surface with very smooth texture.	Mostly specular

Source: Ref. 2, Table 1.

\* - Q<sub>0</sub> = representative mean luminance coefficient.

- c. *Mounting Height.* The height of luminaires above the roadway surface varies from 5 m to more than 30 m. The lower mounting heights are used for tunnel and underpass lighting, pedestrian walkways, and roadways located near or crossing aircraft approach zones. Large trees may also limit mounting heights. The highest mounting heights are used for area lighting, e.g., at freeway interchanges, toll plazas, and parking lots. Conventional roadway lighting utilizes mounting heights of 9 to 15 m. The lower mounting heights require the use of cutoff or semicutoff luminaire distribution to minimize glare. The conventional and higher mounting heights permit greater spacing and the use of larger, more efficient lamps.
- d. *Luminaire Spacing.* Luminaire spacing is often determined by location of utility poles, driveways, property lines, block lengths, and terrain features. It is usually in the interest of both good lighting and good economics to use larger lamps at reasonable spacing rather than smaller lamps at closer spacing and lower mounting heights. The desired uniformity of pavement brightness should be maintained, and the spacing-to-mounting-height ratio should be within the range of light distributions for which the luminaire is designed. On narrow streets, all luminaires may be on one side of the street, or a staggered layout may be used. On wide streets, pairs of luminaires opposite each other, mounted outside the roadway or in the median, may be required. Table 28-2 lists recommended maximum spacings for each vertical distribution class of luminaire.
- e. *Transverse Location.* As discussed in paragraph E.1.b., Type II, III, and IV luminaires are mounted above or near the edge of the roadway, while Type I is suspended over the area to be lighted. Specific location decisions must also consider access to luminaires for servicing, hazards of poles, visibility of traffic control devices, and aesthetics. The transverse distance from the edge of the roadway to a point directly below the luminaire is termed "overhang."
- f. *Light Trespass and Skyglow.* In keeping with other environmental concerns, designers of lighting for roadways, bike trails, and pedestrian paths should consider light trespass and skyglow. These two factors are of such importance in some areas that maximum values are regulated by local ordinance.

- (1) *Light trespass* represents the light flux from a luminaire that falls off the area it was intended to illuminate onto other areas, particularly in residential zones. While some residents might appreciate the security benefits of such lighting, others prefer the privacy represented by darkness. Minimizing light trespass includes both careful design of the light control in a luminaire and proper placement of the luminaire in the lighting installation. Light control to reduce or eliminate light trespass is accomplished with internal or external light shields.

Although the reduction in light trespass often requires nothing more than installing a shield or baffle inside or outside of the errant roadway luminaire, it must be recognized that such modification will to varying degrees compromise the lighting pattern for which the luminaire was designed. This reduction in lighting for the public must be balanced against the benefit of a few citizens. The lighting designer must assume the role of a negotiator, especially if he/she is employed by a public agency. Alternatives that might be suggested in the negotiations are landscaping outside the residence or draperies inside the residence.

- (2) *Skyglow* defines that light flux from a luminaire that goes upward and results in a glow in the sky. It is of particular concern to astronomers, who find that skyglow reduces their ability to fully utilize their telescopes. Although much of skyglow can be greatly reduced by utilizing cutoff type luminaire distribution, skyglow can still result from light that is reflected upward from pavement surfaces, and these should be considered.

## G. Special Situations

- 1 **Road Complexities.** There are many roadway areas where the problem of seeing is more complex than on straight and level sections. These areas have three common factors: (1) the vehicle operator is faced with additional visual tasks upon approaching and traversing them; (2) because of vehicle location, roadway geometry, or other reasons, it may be difficult to provide silhouette seeing; and (3) vehicle headlight illumination may be inadequate since it follows rather than leads the progress of a maneuvering vehicle. These complex areas consist of one or a combination of several of the following basic situations.
  - a. *Grade Intersections.* The illuminance level for an intersection at grade should be the sum of the levels for the intersecting roadways. Luminaires should be located so that both vehicles and pedestrians in and near the intersection area are illuminated.
  - b. *Curves and Grades.* Large radius curves and gently sloping grades may be treated in the same manner as straight, level sections. Sharper curves and steeper grades require closer luminaire spacing in order to provide uniform pavement brightness. Curbs and guardrails should be illuminated.
  - c. *Underpasses.* A short underpass may be illuminated satisfactorily by standard luminaires if those on either side of the underpass are positioned so that their pavement illuminance overlaps beneath the structure. Longer underpasses require special pole or soffit-mounted lighting fixtures for nighttime and possible daytime use (see para. G.4.).
  - d. *Converging Traffic Lanes.* Good direct lighting should be provided on the vehicles entering the main traffic lanes.
  - e. *Diverging Traffic Lanes.* Curbs, abutments, guardrails, and vehicles in the divergence area should be illuminated. Lighting should also be provided in the deceleration zone.
  - f. *High-Speed Interchanges.* Illumination should be provided at points of access and egress, curves, grades, and other areas of geometric and traffic complexity. Luminaires should be placed carefully to avoid giving drivers misleading visual clues.
- 2 **Overhead Traffic Signs.** Overhead traffic signs are illuminated with light sources such as phosphor-coated mercury, metal halide, high-pressure sodium, or fluorescent lamps. The usual and preferred location for sign lighting fixtures is along the bottom edge of the sign panel; this provides the best lighting and permits easy access for maintenance.

At one time, it was considered essential to illuminate all overhead signs because, even though such signs were reflectorized, lower beam vehicle headlights did not provide enough light to sufficiently illuminate them. A recent FHWA requirement that the background as well as the legend and border of overhead signs be reflectorized, and the need to save energy, has led some agencies to turn off certain sign lighting. California, for example, now illuminates only signs located at points where drivers must make decisions, e.g., at freeway off-ramps; other signs rely solely on headlights and retroreflectivity.

- 3 **Railroad Crossings.** Grade crossings of streets and railroads should be illuminated to indicate the presence of a train or railroad car within the crossing at night. RP-8-00 recommends that, for basic crossing lighting, fixtures be placed on the near side of both highway approaches. In addition, it is suggested that an additional fixture be placed along each railroad approach to illuminate the side of the railroad cars, keeping in mind that such fixtures should not interfere with the view of the crossing by the train operator.
- 4 **Tunnels.** Lighting tunnels is unusual because they require a higher level of lighting in daytime than at night. Daytime levels at the entrance must be such that an approaching driver should be able to discern a stopped vehicle or other object inside the tunnel in time to react properly. In the center, lighting must ensure good visibility, to give drivers a feeling of security. A poorly lighted tunnel can result in accidents, difficulty in lateral placement of vehicles, and slowing of vehicles on entering the tunnel. Refs. 5 (p.100-105) and Ref. 7 contain good information on tunnel lighting.
- 5 **Alleys.** Alleys are often lighted to deter crime.
- 6 **Parking Facilities.** Lighting must be provided in garages and in those open lots that are used after dark to provide for the safe and orderly movement of vehicles and pedestrians, to provide pedestrian security, and to deter theft and vandalism. IESNA publication RP-20-98 (Ref. 8) includes separate tables of recommended illuminance values for parking lots and garages. For lots there are two sets of lighting levels, "basic" and, with higher lighting levels, "enhanced security." The recommended values for garages include minimum vertical illuminance levels.

## H. Benefits of Roadway Lighting

In 1989, a task force of the Illuminating Engineering Society of North America, chaired by Paul C. Box, reported on a study made to determine the benefits of roadway lighting (Ref. 9). Essentially, this report concludes:

- Adequate lighting that is properly designed, installed, and maintained can usually significantly reduce night accidents.
- On major streets in urban areas, the greatest benefit from lighting modernization came in the reduction of nighttime pedestrian accidents by from 45 to 80 percent. The reduction of all types of nighttime accidents was in the range of 21 to 36 percent.
- Adequate lighting can reduce specific types of crimes from 10 to 90 percent. Lighting of streets to standards adequate for traffic safety will afford added personal security to pedestrians using adjacent sidewalks at night.

The report recognizes and identifies the limitation of lighting studies as:

- Inadequacies in defining various elements relating to quality in lighting design, such as glare control, pavement luminance, and contrast discrimination.
- Consideration of effect of unexpected changes in traffic conditions and adjacent land use.
- Problems with subjectivity of the researcher in identifying changes in condition.

The section titled "Economics" in this report will be of particular interest to the public agency engineer asked to justify roadway lighting on a benefit-cost basis.



## I. Recent Developments

Although there have been no significant changes in lighting design aside from an IESNA proposal to standardize the method presentation of luminaire performance data, there have been substantive improvements in environmental considerations, equipment, light sources, and monitoring.

- 1 **Light Source Color.** Recent research has indicated that so-called "bluer or whiter" light sources provide better visibility than the "yellow" light of High Pressure Sodium (HPS) and Low Pressure Sodium (LPS) lamps at the lighting levels used for roadway lighting. The "whiter" light of such sources as Metal Halide (MH) in particular has therefore come into favor. As a result MH lamps have gone through significant improvements that have resulted in better starting characteristics, better efficacy, and longer life. As a whole, the life of MH lamps is still less than that of HPS and Mercury lamps, particularly in the lower wattages; but this has not discouraged the expanded use of MH lamps, as many designers prefer the superior color-rendering of MH lamps.
- 2 **HID Lamp Ballast.** Until recently, the ballasts used for HID lamps in roadway lighting applications have been of the magnetic or "core and coil" type. They consist of a ferrous laminated core wound with copper wire, a starter, and a capacitor or condenser where power factor correction is required. This type of ballast has to a limited extent been replaced by the electronic ballast in roadway lighting. Electronic ballasts consist of a circuit that generates a high-frequency voltage (in the neighborhood of 20 Kilohertz), a starter, and a current limiting reactor. Since HID lamps operate at improved efficacy at higher frequencies, the advantage of this type of ballast is readily apparent. In addition, the electronic ballast's high-frequency circuitry permits the use of much smaller current-limiting reactors and ballast operation at a high power factor. Electronic ballasts are also available that permit dimming of HID lamps used for roadway lighting.
- 3 **LED Roadway Lighting.** The newest light source for roadway lighting is the light emitting diode (LED). The first LEDs were able to produce only red light, but continued development has resulted in the current generation of LEDs being capable of providing white light. Further improvements have included increases in both light output and life. In general the LED is characterized by high efficacy and long life, but also by a sensitivity to operating current and ambient temperature. These last two items have been remedied by the use of electronic power supplies that recognize and correct operating current and temperature problems so as to maintain a constant light output over a long period of time. The major problem with the LED when applied to roadway luminaires is that the low light output of individual LEDs requires a number of them to be grouped for use in high light output luminaires, resulting in a large-sized light source. The result is that the optical assembly of LED roadway luminaires must be larger than it would be for the usual HID light source.
- 4 **Luminaire Aesthetics.** There has been some restyling of the aged "cobra head" housing shape to provide a more esthetic appearance. One manufacturer now offers such a restyled fixture in 188 different colors. This same manufacturer's fixture housing is top opening to permit the lens to be better sealed and gasketed, and to permit easier access to the lamp and ballast.
- 5 **Remote Monitoring and Control.** The monitoring function can alert a central maintenance facility via radio or carrier frequency over power lines to the presence of burned-out lamps. While adding cost, this feature eliminates the need for and cost of night patrols by maintenance personnel and reduces the risk of litigation due to burned-out lamps. Remote control refers not only to simple "on" and "off" switching, but also the ability to operate dimmable HID ballasts. One such device consists of a 140 mm (5½") diameter by 90 mm (3½") high housing that is inserted between the photocontrol and the photocontrol socket on the top of a luminaire. The device takes its power from the photocontrol socket and sends and receives data via a 900 MHz radio channel. As presently designed, the data is sent to a vendor-owned server, which must be accessed by the user via a telephone line.

## REFERENCES

1. Illumination Engineering Society of North America. *The IESNA Lighting Handbook, Reference & Application*. New York, NY: 2000. Chapters 1-4, 6-8, 22.
2. Illuminating Engineering Society of North America. *American National Standard Practice for Roadway Lighting*, ANSI/IES RP-8, 1983, approved July 21, 1983.
3. Illuminating Engineering Society of North America. *American National Standard Practice for Roadway Lighting*, ANSI/IES RP-8-00, approved August 8, 1999.
4. California Department of Transportation. *Traffic Manual*. Sacramento, CA: updated periodically. Sec. 9-11.4.
5. U.S. Federal Highway Administration. *Roadway Lighting Handbook*. Washington, DC: U.S. GPO, Dec. 1978, 248 p.
6. U.S. Federal Highway Administration. *Designing the Lighting System Using Pavement Luminance*. Addendum to Chap. 6 of Ref. 5. Washington DC: U.S. GPO, Sept. 1983. 50 p.
7. Illuminating Engineering Society of North America. *American National Standard Practice for Tunnel Lighting*. ANSI/IES RP-22-96. New York, NY: 1996. 31 p.
8. Illuminating Engineering Society of North America. *Lighting for Parking Facilities*. New York, NY: RP-20-98. 1998. 40 p.
9. Illuminating Engineering Society of North America. *Value of Public Roadway Lighting*. New York, NY: Report IES CP31-1989, 1989.



### A. Policy

The National Environmental Policy Act (NEPA) of 1969 (Ref. 1) declares it national policy "to use all practicable means and measures...to create and maintain conditions under which man and nature can exist in productive harmony, and fulfill the social, economic, and other requirements of present and future generations of Americans." NEPA "sets a vision for how the government should work to incorporate protection and enhancement of the environment into its decisions and actions." (Ref. 2, p. 1)

Specifically, NEPA requires that "every recommendation or report on proposals for legislation or other major federal actions significantly affecting the quality of the human environment" be accompanied by a statement on:

- 1 the environmental impacts of the proposed action;
- 2 any adverse environmental effects which cannot be avoided should the proposal be implemented;
- 3 alternatives to the proposed action;
- 4 the relationship between local short-term uses of the human environment and the maintenance and enhancement of long-term productivity; and
- 5 any irreversible and irretrievable commitments of resources which would be involved if the proposed action were to be implemented.

At the state level, the California Environmental Quality Act (CEQA) (Ref. 3) adds several additional requirements to NEPA. These requirements, found in § 21100 and § 21081, state:

- 1 mitigation measures must be proposed to minimize significant environmental effects including, but not limited to, measures to reduce the wasteful, inefficient, and unnecessary consumption of energy; and
- 2 the growth-inducing and employment reduction impacts of the proposed action be identified.

The basic purposes of CEQA are to:

- 1 Inform governmental decision-makers and the public about the potential significant environmental effects of proposed activities.
- 2 Identify the ways that environmental damage can be avoided or significantly reduced.
- 3 Prevent significant, avoidable damage to the environment by requiring changes in projects through the use of alternatives or mitigation measures when the governmental agency finds the changes to be feasible.

---

\* Substantial contributions to this chapter were made by Diana Gould Wells of California Polytechnic State University, San Luis Obispo.

NEPA and CEQA provide that such studies be performed (unless exempt - see Sec. B.) and that mitigation measures or environmentally superior alternatives be proposed (CEQA § 21002).

However, they do not require that proposed actions be modified or cancelled if an adverse environmental impact is identified. The intent of the legislation is to inform decision makers about all significant environmental impacts. Thereafter, as stated in a court interpretation (Ref. 4), "if the decision makers choose to ignore such [negative] factors, they will be doing so with their eyes wide open."

Most states have enacted similar legislation. In California, CEQA extends the requirement for impact statements to state and local government actions and to private projects which involve contracts, loans, grants, leases, permits, or licenses from a public agency. The Act also requires each city, county, and other local agency to adopt its own implementation procedures to meet the guidelines issued by the California Resources Agency (Ref. 5).

Regulations and additional guidance on implementing NEPA were issued in 1978 and 1983 by the federal Council on Environmental Quality (CEQ) (Refs. 6, 7, and 8). The corresponding CEQA guidelines (Ref. 5) are updated frequently.

The requirements in federal and California legislation are somewhat different. However, California law provides that, if a federal document must be prepared, all or part of that statement can serve the requirements of the CEQA. Terminology also differs (see Table 29-1).

**Table 29-1-Federal and California Environmental Impact Legislative Terminology**

	<b>United States</b>	<b>California</b>
Short name for environmental act	NEPA	CEQA
Preliminary analysis	Environmental Analysis (EA)	Initial Study (IS)
Document justifying no further action	Finding of No Significant Impact (FONSI)	Negative Declaration (ND)
Full environmental document	Environmental Impact Statement (EIS)	Environmental Impact Report (EIR)

## B. Exemptions from the Environmental Impact Study Process

Almost any action by any governmental agency is a candidate for environmental impact analysis. However, after consideration, many projects can be excluded. The steps taken to make this determination are shown schematically in the CEQA process flowchart of Fig. 29-1.

- 1 **No Federal Study.** Exempt are all non-federal projects (no federal aid or other important participation) and those on a list that qualify for categorical exclusions, such as planning studies, safety projects, and minor alterations and rehabilitation within existing rights-of-way. For a complete list of "categorical exclusions," see Ref. 9, § 771.117(b).
- 2 **No California Study.** The following types of actions are excluded from the requirement to proceed with an initial study (IS):
  - a. Ministerial actions required by law, over which the governmental agency has no discretion.
  - b. Emergency repairs to maintain service.
  - c. Maintenance, repair, or replacement of facilities damaged or destroyed in a disaster.
  - d. Actions required to prevent a disaster.
  - e. Projects rejected by a public agency. (The refusal to act is not subject to an EIR.)
  - f. Changes in tolls, transit fares, parking charges, etc. to meet operating and capital expenses (though courts have ruled changes in tolls require environmental impact studies).
  - g. Projects to increase passenger service on existing railroads.
  - h. Development of transportation improvement plans.
  - i. Projects which by their nature are not likely to have a significant effect on the environment and which have been placed in a list of "categorical exemptions," such as:

# CEQA PROCESS FLOW CHART

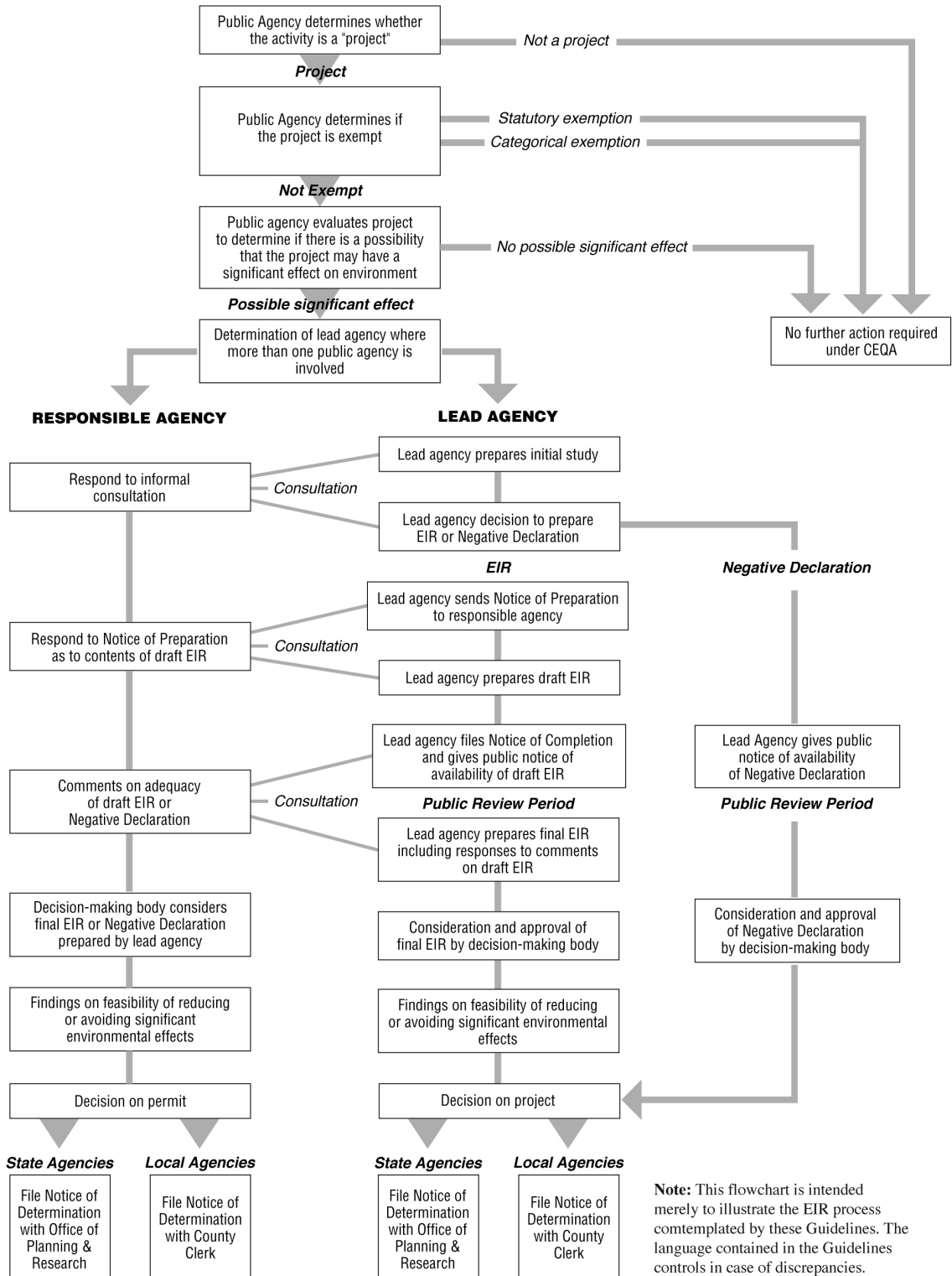

Last modified 5/25/2005 - Document URL: [http://ceres.ca.gov/topic/env\\_law/ceqa/flowchart/index.html](http://ceres.ca.gov/topic/env_law/ceqa/flowchart/index.html)  
 Copyright © 1998-2003 California Resources Agency. All rights reserved.

**Fig. 29-1-CEQA Process - Determining the Need to Conduct an Environmental Impact Study**

- (1) Operation, repair, maintenance of, and minor alteration to existing facilities (e.g., pavement resurfacing, widening of less than a lane or a shoulder, modification of traffic control systems and devices, landscaping, construction of medians or noise barriers).
- (2) Replacement or reconstruction of an existing facility, such as a bridge.
- (3) New construction of small structures, such as bus shelters.

For a complete list of categorical exemptions, see Ref. 5, Article 18, and Ref. 10, Article 10.

- 3 **Preliminary Analysis.** If a project does not fall into one of the exempt classes, a preliminary analysis (EA/IS) is conducted to decide whether the project is likely to have a significant impact on the environment. California guidelines were updated in 1998 to help clarify whether impacts should be judged "significant" (Ref. 11). A checklist (e.g., Ref. 12, Vol. 1, Exhibit 3-2) is often used. The result is either a negative declaration or a complete environmental study.
- 4 **Negative Declaration.** If the preliminary analysis shows that no significant impact is likely to occur, a FONSI/ND (see Table 29-1) is prepared. This consists of a brief description of the proposed project or action, a presentation of the findings of the EA/IS (which is attached to the FONSI/ND), and a statement of the reasons for these findings.

### C. Environmental Impact Statement Content

If the project does not qualify for exemption or a FONSI/ND, a complete environmental impact study is conducted. Many documents on general analyses and case studies of environmental assessments have been published. Both the federal and California DOTs have published detailed handbooks on integrating environmental analysis with transportation projects and plans (Refs. 2, 12, 13, 14, and 15). Also, the spring 1995 issue of *Public Roads* (Ref. 16) presented an overview of FHWA's policy; ITE's *Transportation Planning Handbook* (Ref. 17) summarizes policy history and technical analysis; and legal issues are presented in NCHRP Legal Research Digest #29 (Ref. 18).

The final environmental document (EIS/EIR) is first published as a "Draft" (the DEIS/DEIR) and made available to all interested agencies and the public, whose comments are included in the final version of the EIS/EIR (the FEIS/FEIR). The principal sections of this document are (Ref. 12, Vol. 1, Sec. 3-4):

- Summary.
- Table of Contents.
- Purpose of and Need for Project.
- Alternatives Including Proposed Project.
- Affected Environment.
- Environmental Consequences and Mitigation Measures.

Court interpretations of both federal and California environmental impact laws have determined that the intent of these laws is fulfilled only if the EIS/EIR meets the following requirements:

- 1 The EIS/EIR is a full disclosure document. Therefore, it must thoroughly discuss the significant aspects of the probable environmental impact of the proposed action or project. By the same token, there is no need to discuss either insignificant matters or remote and improbable effects (Ref. 19).
- 2 The EIS/EIR must be simple enough for laypersons to understand and at the same time be detailed enough for experts to be alerted to specific details. "It must be written in language that is understandable to non-technical minds and yet contain enough scientific reasoning to alert specialists to particular problems within the field of their expertise." (Ref. 19).
- 3 The EIS/EIR is a decision-making tool; therefore, it should be prepared as early as possible in the planning process to enable environmental considerations to influence the project program and design.

- 4 Additional important factors in an EIR/EIR include:
  - a. A thorough project description documenting all aspects of the proposed project. There are many court cases citing inadequate project descriptions, which allowed projects to slip through the environmental review process without adequate environmental evaluation.
  - b. Description of the environmental setting (CEQA § 15125), including a discussion of any inconsistencies between the proposed project and existing general plans, regional plans, air quality management plans, etc. If a project is inconsistent with the plans, it is generally considered to have significant environmental impacts.
  - c. Identification of significant avoidable impacts.
  - d. Proposed mitigation measures.
  - e. Project alternatives, with the "no project" alternative as one possibility.

## D. Environmental Impacts

The specific environmental aspects to be considered are not spelled out in the federal law. The U.S. Department of Transportation has developed the following impact categories for consideration in federal-aid transportation projects (Ref. 15, Chap. 5):

- 1 Land Use and Economic Development Impacts
- 2 Displacement and Relocation of Existing Uses
- 3 Neighborhood Social Impacts
- 4 Visual and Aesthetic Impacts
- 5 Air Quality
- 6 Noise and Vibration
- 7 Ecosystems (Flora and Fauna)
- 8 Water Quality and Floodplain Impacts
- 9 Energy Consumption
- 10 Historic and Archaeological Impacts
- 11 Impacts on Parklands
- 12 Impacts During Construction

The California guidelines (Ref. 5, § 15122-15131) generally cover the same impact categories as above, although these categories are organized differently.

Analyzing this diversity of environmental impacts involves many professions and disciplines. Thus, detailed discussion of these analyses is beyond the scope of this chapter. Consideration of air pollution, noise, and energy resources, however, are so intimately connected with transportation and traffic engineering that some familiarity with basic concepts in these areas is necessary. Therefore, these topics are summarized in Chaps. 30-32. Brief mention is made here of some other environmental concerns which often play important roles in transportation projects.

- 1 **Water Quality:** Water quality is protected by special legislation in addition to NEPA and CEQA (Ref. 12, Sec. 1-3.4; Ref. 18). Of particular concern are:
  - a. Silting and erosion caused by construction activities.
  - b. Change in water courses, and resulting effect on aquatic life.
  - c. Chemical composition of water, possible pollution from construction activities, deicing salts, etc.
  - d. Change in ground water quality due to seepage of chemicals or salts, or other causes.
- 2 **Wetlands, Coastal Zones, and Lakes:** The preservation of wetlands is subject to a special study required by federal executive order. California has special constitutional provisions dealing with the protection of coastal areas, bays, beaches, and tidelands (Ref. 12, Sec. 1-3.7; Refs. 18, 20 and 21).
- 3 **Historic Places or Structures:** Historic places, including archeological sites, buildings placed on the Register of Historic Places, and others, are protected under a variety of legislation (Ref. 12, Sec. 1-3.5; Ref. 18) be adversely modified (Ref. 12, Sec. 1-3.8; and Ref. 22).



- 4 Enhancement, Scenic Byways, and Recreation:** Design and construction efforts should preserve and enhance the existing resources and provide recreational opportunities, particularly travel options for bicyclists and pedestrians (Refs. 16 and 23).

AASHTO has published *A Guide for Transportation Landscape and Environmental Design* (Ref. 24), which provides a good summary of the relationships between design and environment without technical details. It also gives numerous references on related topics.

#### REFERENCES

1. U.S. Government. *Public Law 91-190*, Jan. 1, 1970, as amended through 1982. On-Line. Internet. November 2004. Available: <http://ceq.eh.doe.gov/nepa/regs/nepa/nepaeqia>. (Included in Ref. 12, Vol. 1, as Appendix A-1.)
2. Federal Highway Administration. *Transportation Project Development and NEPA*. March, 2004. On-Line. Internet. November 2004. Available: <http://environment.fhwa.dot.gov/projdev/index.htm>.
3. California. *Public Resources Code*, Division 13, 1970, as amended July 27, 2004. On-Line. Internet. November 2004. Available: <http://ceres.ca.gov/ceqa/>. (Included in Ref. 12, Vol. 1, as Appendix A-3.)
4. Environmental Defense Fund, Inc. v. Corps of Engineers, 325 F.Supp., 749, 759 (E.D. Ark. 1971).
5. California Resources Agency. "Guidelines for Implementation of the California Environmental Quality Act." *California Administrative Code*. Title 14, Division 6, Chapter 3, as amended September 2004. On-Line. Internet. May 2005. Available: [http://ceres.ca.gov/topic/env\\_law/ceqa/guidelines/](http://ceres.ca.gov/topic/env_law/ceqa/guidelines/). (Included in Ref. 12, Vol. 1, as Appendix A-4.)
6. Federal Highway Administration. *Regulations to Implement the FHWA NEPA Process*. May 2005. On-Line. Internet. November 2004. Available: <http://environment.fhwa.dot.gov/strmlng/index.asp>.
7. U.S. Government. *Code of Federal Regulations*. Title 40, Part 1500. 1978. On-Line. Internet. November 2004. Available: [http://ceq.eh.doe.gov/nepa/regs/ceq/toc\\_ceq.htm](http://ceq.eh.doe.gov/nepa/regs/ceq/toc_ceq.htm).
8. Council on Environmental Quality. "Guidance Regarding NEPA Regulations (40 CFR Part 1500)." 48 Federal Register 34263. 1983. On-Line. Internet. November 2004. Available: <http://ceq.eh.doe.gov/nepa/regs/1983/1983guid.htm>.
9. U.S. FHWA and U.S. UMTA. "Environmental Impact and Related Procedures; Final Rule." Federal Register, v. 52, n. 167, pp. 32646-32669, Aug. 28, 1987. (Included in Ref. 12, Vol. 1, as Appendix A-2.)
10. California Dept. of Transportation. *Regulations for Implementation of the California Environmental Quality Act of 1970*. Sacramento, CA: 1978. (Included in Ref. 12, Vol. 1, as Appendix A-5.)
11. Gorsen, Maureen. *1998 CEQA Guidelines Revisions: What Every CEQA Practitioner Needs to Know*. California Resources Agency. October 1998. On-Line. Internet. November 2004, Available: [http://ceres.ca.gov/ceqa/ceqa\\_article\\_1098.html](http://ceres.ca.gov/ceqa/ceqa_article_1098.html).
12. California Dept. of Transportation. *Environmental Handbook*. Sacramento, CA: updated March 2004; loose leaf; 4 volumes. On-Line. Internet. Nov. 2004. Available: <http://www.dot.ca.gov/ser/envhand.htm>.
13. Federal Highway Administration. *The Environmental Guidebook*. November 24, 1999. On-Line. Internet. November 2004. Available: <http://environment.fhwa.dot.gov/guidebook/index.htm>.
14. U.S. Dept. of Transportation. *A Guide to Metropolitan Transportation Planning Under ISTEA - How the Pieces Fit Together*. Washington, DC. 1995, 42 p. On-Line. Internet. Nov. 2004. Available: [http:// ntl.bts.gov/](http://ntl.bts.gov/).

15. National Highway Institute. *Estimating the Impacts of Urban Transportation Alternatives - Participant's Notebook*. NHI Course No. 15257. Federal Highway Administration. FHWA-HI-94-053. Dec. 1995.
16. Federal Highway Administration. *Public Roads*. v. 58, n. 4. Washington, DC: Spring 1995.
17. Institute of Transportation Engineers. "Environmental and Energy Considerations." In: Edwards, John D., Jr. (Editor). *Transportation Planning Handbook*. Second Edition. Washington, D.C.: I.T.E., 1999.
18. "Highways and the Environment: Resource Protection and the Federal Highway Program." NCHRP *Legal Research Digest* 29. Washington DC: Transportation Research Board, October 1994, 46 p.
19. Environmental Defense Fund, Inc. v. Corps of Engineers, 348 F. Supp., 916 (N.D. Miss. 1972).
20. De Santo, R.S. and T.A. Flieger. "Wetland Functions and Values: Descriptive Approach to Visualizing and Assessing Wetland Systems." *Transportation Research Record* 1475. 1995, pp. 123-132.
21. Fenke, A., N. Caiazza, L.O. Morgan, and K.P. Dunne. "Interstate 287 Wetland Mitigation Project: Turning an Environmental Liability into an Environmental Asset." *Transportation Research Record* 1444. 1994, pp. 64-68.
22. Hanson, R.P. and J. Hummer. "Examination of State Policies on Endangered Species and Transportation Projects in the United States." *Transportation Research Record* 1444. 1994, pp. 51-58.
23. Eisen, V.A., D.G. Murray, and A. Eliot. "Developing Enhancements Program in San Francisco Bay Area." *Transportation Research Record* 1444. 1994, pp. 173-179.
24. American Association of State Highway and Transportation Officials. *A Guide for Transportation Landscape and Environmental Design*. Washington, DC: June 1991, 163 p.



## A. Introduction

Air pollution is the contamination of the ambient air by deleterious chemical compounds or particulate solids in a concentration that adversely affects human and animal health, materials, vegetation, or aesthetics. Ambient air quality standards have been set to protect the public from adverse air quality. Both the California Air Resources Board (CARB) and the U.S. Environmental Protection Agency (U.S. EPA) are authorized to set ambient air quality standards. Air pollution may be caused by nature or by human activity. Dust, smoke, pollen, and wind-transported salts are natural air pollutants. Major air pollutants caused by human activities include carbon monoxide, oxides of sulfur and of nitrogen, reactive volatile organic compounds, and particulates. Climatic conditions, industrial activity, transportation patterns, and fuel types used determine the nature of the air pollution problem.

This chapter provides only an introduction to the relationship between highway traffic and air pollution. The reader should seek more in-depth discussion provided in the references prior to attempting any technical analysis of air pollution. With the enactment of ISTEA and TEA-21, air quality issues in transportation have been emphasized more than before (see Sec. L), and traffic engineers should be very aware of their role in emissions control.

## B. Air Quality Determinants

The important elements influencing air quality in any situation are:

- Air pollutant sources present,
- Local meteorology, especially temperature and wind speed,
- Natural topography,
- Land use activities and their locations,
- Transportation facilities, their design, and their levels of service.

All sources in an area contribute to the air pollution in that area. Natural topography and local meteorology determine the type and degree of the air pollution problem. Land use activities and transportation facilities, and their relative locations and levels of use, determine how and to what degree people and their activities are affected. (Ref. 1) The cumulative impacts of air pollution resulting from motor vehicles emissions can be substantial.

## C. Scale of Air Pollution Problems

The scale of the area considered is a primary determinant for defining whether and what kinds of air pollution problems exist. Pollutant types and concentrations that may be serious at one scale are not necessarily serious at another. The scales of concern are:

---

\* Substantial contributions to this chapter were made by Diana Gould-Wells of California Polytechnic State University, San Luis Obispo, and to earlier versions by Professors Robert D. Layton of Oregon State University and Elizabeth A. Deakin of the University of California, Berkeley.

- 1 **Global:** At this scale there is concern about "greenhouse" gas buildup (carbon dioxide, nitrogen oxides, ozone, and methane), global warming, and the effect of aerosols (CFCs and halons) and other pollutants on the protective ozone layer in the upper atmosphere. Problems are long-term, and correction depends on long-term measures to reduce emissions of damage-causing compounds.
- 2 **(Inter)continental:** Problems at this scale include acid rain pollution from sulfur oxides contained in airborne moisture, but also may include long-distance transport of other pollutants. Polluted air masses causing acid rain dissipate in a short time period, but the effects on water and soil may be long lasting.
- 3 **Regional:** This scale corresponds to a single air basin that has a common weather pattern and air mass. Many air quality standards are set at this scale. Regional problems typically have short durations, usually days, after which air currents transport and diffuse pollutants throughout the atmosphere. Climatic conditions that stagnate the air within a region lead to high emission concentrations from which large quantities of derivative compounds form through chemical and photochemical reactions.
- 4 **Local:** Local pollution problems occur in the vicinity of the polluting sources. They may be found in downtown areas, steep valleys, around busy intersections, near toll plazas and air terminals, and downwind of stationary sources. Standards also exist at this scale. The air mass is normally not confined for more than a few hours. As a result, most of the pollutant species are direct emission products.
- 5 **Confined Space:** Confined space air pollution may occur wherever physical barriers restrict air movement; e.g., outdoors in some street "canyons" between high-rise buildings or inside tunnels and parking garages. The longevity of an air pollution problem in a confined space depends on its shape and the exhaust system provided.

#### D. Air Pollutant Emission Species and Mechanics of Photochemical Smog

The major direct pollutant species present in emissions are:

- 1 **Hydrocarbons (HC):** incompletely burned or evaporated fuels and solvents, produced by mobile sources and industrial processes. Reactive volatile organic compounds (RVOC), sometimes also called reactive organic gases (ROG) or non-methane hydrocarbons (NMHC), are of great concern because these compounds react to form smog.
- 2 **Nitrogen oxides (NO<sub>x</sub>):** products of high-compression internal combustion engines, power plants, and other large burners. These are significant because they are considered to be precursors to ozone formation and smog.
- 3 **Carbon monoxide (CO):** a product of incomplete burning of fuel, produced by motor vehicles (the primary source), home heating, and, to a lesser extent, industrial activities.
- 4 **Sulfur oxides (SO<sub>x</sub>):** products of burning sulfur-rich fossil fuels, particularly coal, mostly produced by electricity generation and other industrial activities, with minor emissions from motor vehicles.
- 5 **Particulates:** mostly carbon particles like soot; however, fine particles of dust, metals, asbestos, and suspended droplets are also included. They are produced by industry, motor vehicles, and natural processes. Fugitive dust, which is now reported in statistical data, comes from sources such as agricultural tilling, construction, mining and quarrying, paved and unpaved roads, and wind erosion. New standards promulgated in 1997 deserve the attention of transportation planners and traffic engineers.
- 6 **Lead:** the result of burning leaded gasoline and also produced by smelters.

CO effects are frequently confined to the vicinity of the source, within about 0.4 km. Other species impact on the air basin scale and beyond. Dispersion increases with temperature and is accelerated by convection currents, unless an inversion layer holds the air mass in place.

Table 30-1 shows trends in the quantities of pollution emitted by the above species since 1970. In most cases, downward trends are seen.

The chemistry of air pollution is very complex because of the wide variety of species and because of the variability of meteorological conditions. In smog, pollutants are formed through photochemical reactions, which take place in the lower atmosphere. Prime reactants are hydrocarbons and  $\text{NO}_x$ , the latter predominantly in the form of  $\text{NO}_2$ .

The formation of photochemical smog begins with the reaction of  $\text{NO}_2$  as it is exposed to sunlight. The atomic oxygen that is formed from this reaction then interacts with molecular oxygen to form ozone ( $\text{O}_3$ ) or reacts with other organic compounds, causing them to oxidize. The latter type of reaction occurs when ozone reacts with  $\text{NO}$  to form more  $\text{NO}_2$ . Products of secondary reactions between emissions and products of previous reactions include peroxyacylnitrates (PANs), peroxides, mercaptans, acrolein, olefins, and aldehydes.  $\text{SO}_2$  in low concentrations may contribute to the acceleration of photochemical smog formation.

**Table 30-1—Quantities of Pollutants Emitted, U.S. - 1970-2001**

Year	(Millions of metric tons per year)				
	CO	VOC	$\text{NO}_x$	$\text{SO}_x$	PM-10*
1970	185.1	31.4	24.4	28.3	NA
1980	168.2	28.2	24.6	23.5	NA
1985	160.4	24.9	23.4	21.1	27.0
1990	139.9	21.9	23.2	20.9	16.4
1995	115.0	20.0	22.6	16.9	15.4
1997	107.0	17.7	22.4	17.1	13.2
2000	112.1	17.9	21.0	14.8	13.0
2001	109.6	16.3	20.3	14.3	13.3

Source: Calculated from Ref. 3

\* - PM-10 – Particulate matter less than  $10\mu\text{m}$  in diameter.  
This was not measured prior to 1985.

## E. Pollution Sources

Air pollutants are emitted by a variety of major sources described below. Their relative contributions to total air pollution in the United States for the year 2001 are shown in Table 30-2.

**Table 30-2—Proportions of Air Pollutants by Source, U.S.—2001**

Source	(Percent of total for each pollutant)				
	CO	VOC	$\text{NO}_x$	$\text{SO}_2$	PM-10
<b>Mobile Sources</b>	<b>82.4%</b>	<b>41.7%</b>	<b>55.5%</b>	<b>4.4%</b>	<b>2.2%</b>
Highway Vehicles	62.0%	27.1%	36.9%	1.7%	0.9%
Gasoline	61.0%	25.9%	19.4%	1.2%	0.4%
Diesel	1.0%	1.2%	17.5%	0.5%	0.5%
Off-Highway*	20.4%	14.6%	18.6%	2.7%	1.3%
<b>Industrial Processes†</b>	<b>3.2%</b>	<b>42.4%</b>	<b>15.7%</b>	<b>23.3%</b>	<b>4.5%</b>
Electric Power Plants	0.4%	0.4%	21.9%	68.5%	2.8%
Other Stationary Fuel Combustion	2.4%	5.3%	4.8%	3.5%	2.1%
Waste Disposal	2.7%	3.0%	0.8%	0.2%	2.1%
Miscellaneous‡	8.9%	7.2%	1.4%	0.1%	86.3%

Source: Calculated from Ref. 3.

\* Farm machinery, construction equipment, recreational marine vessels, lawn mowers, etc.

† Includes solvent utilization, storage and transport.

‡ Forest fires, other agricultural activities, fugitive dust from paved and unpaved roads, other construction and mining activities, and natural sources.

- 1 **Mobile Sources:** Motor vehicle emission characteristics are discussed in Sec. F.
- 2 **Industrial Processes:** The emission from industrial sources include smoke, ash, dust, mists, fumes, flue gases, and invisible products of combustion, such as carbon monoxide, sulfur oxides, gaseous fluorides, and numerous organic compounds.
- 3 **Power Plants:** Power plant emissions depend on the fuels used. Much coal, a prime fuel, has a high sulfur content resulting in emissions with high concentrations of sulfur oxides and hydrogen sulfides—principal sources of "acid rain."
- 4 **Other Stationary Fuel Combustion:** A variety of fuels, such as coal, natural gas, and fuel oil, are used to heat buildings, provide hot water, cook food, etc.
- 5 **Waste Disposal:** Commercial and residential incineration produce large volumes of pollutants; major types are particulates, organic compounds, and CO.
- 6 **Forest Fires, Agriculture, and Construction:** These events and activities produce fugitive dust and, where burning takes place, hydrocarbons, smoke, and other particulates.
- 7 **Paints and Architectural Finishes:** Hydrocarbons are released by evaporation of petroleum-based paints. Of particular concern to traffic engineers is that use of such paints for pavement markings is now prohibited in some non-attainment air basin regions.

## F. Automobile Emission Characteristics (Refs.2, 4, 5, 6)

A significant portion of the emissions in urban areas is generated by highway vehicles. The nature and concentration of these emissions vary with the type of engine, the mode of operation, the fuel composition, the presence and working condition of emission control devices, atmospheric conditions, and engine tuning. The impacts of these variables on emission concentration differ for the various pollutants.

In general, an engine operates at a low ratio of air to fuel ("rich mixture") when starting or accelerating, at a mid-range air-to-fuel ratio when idling, and with a high ratio ("lean mixture") when cruising or decelerating. The completeness of combustion, which also affects emissions, is relatively low when decelerating and idling. The impacts of these variables on emission concentration differ for the various pollutants, as described in the following paragraphs.

- 1 **Carbon Monoxide:** The concentration of CO emitted drops rapidly with increasing leanness of the air/fuel mixture to the stoichiometric ratio, and then remains very low because fuel combustion is more complete in this range of fuel mixtures. High CO concentrations are emitted at idle and during deceleration, low concentrations during acceleration and cruising. The type of fuel and mode of operation also influence CO levels. High-octane gasoline, produced by refining or with additives, generates less CO. Oxygenated gasoline, whose oxygen content ranges from 2.0% to 2.7% by weight compared to about 0.3% for non-oxygenated fuel, also reduces CO emissions and is required in about forty urban areas of the U.S. in winter months. California's reformulated gasoline (see J.3. below) is expected to reduce CO emissions by about 11%.

The CO emissions from diesel engines are so low that they are not a problem. Typically, diesel exhaust contains only 0.2% CO. Diesel fuels are less volatile and burn more completely.

- 2 **Hydrocarbons:** For a given compression ratio, the HC concentration in the exhaust decreases with increasing leanness of the fuel/air mixture to the stoichiometric ratio, but then increases in conventional engines when the mixture becomes even leaner. More HC is emitted during idling and deceleration than under cruising or acceleration. Cruising at low speeds tends to produce more emissions of this type than at intermediate speeds, but the emission rate increases again at speeds above 80 km/h. The HC concentration decreases as the engine compression ratio decreases. Diesel engines emit less unburned organic material than spark ignition engines. However, the odor of this component of the exhaust is unpleasant. HC is also emitted from fuel evaporation in the fuel tank and carburetor, and from blow-by, but emission controls have reduced this pollution source.

- 3 **Nitrogen Oxides:** The oxides of nitrogen are recognized as major contributors to photochemical smog. Consequently, the control of nitrogen oxide ( $\text{NO}_x$ ) emissions from gasoline engines, which are a prime source of these compounds, is very important. At exhaust, the predominant pollutant species of the  $\text{NO}_x$  is nitric oxide (NO). Subsequently, at lower temperatures and in the presence of air, NO is converted to nitrogen dioxide ( $\text{NO}_2$ ).

The concentration of  $\text{NO}_x$  depends primarily on the temperature of combustion. Thus, high concentrations of  $\text{NO}_x$  are found during acceleration and when cruising at high speeds. Lower concentrations are noted during deceleration and even lower during idle.

The concentration of  $\text{NO}_x$  is highest for air/fuel ratios near the stoichiometric ratio, decreasing as the mixture becomes either richer or leaner. This is almost the inverse of the HC emission pattern. Increasing compression ratios with the associated higher combustion temperatures tend to increase  $\text{NO}_x$  emissions. Spark ignition timing also affects the  $\text{NO}_x$  concentrations significantly, the quantity increasing as the spark is advanced.

- 4 **Particulates:** Emitted particulates consist primarily of carbon particles, lead compounds, and motor oil. The effects of engine design, fuel/air ratio, and mode of operation on the emissions of particulates are not established due to the complexity of the phenomena involved. Diesel engines emit a significant amount of smoke, which may be carbon particles (black smoke) or unburned HC (white smoke).

## G. Effects of Air Pollution

The human health effects of poor air quality are far reaching, but principally affect the body's respiratory and cardiovascular systems. Individual reactions to air pollutants depend on the types of pollutants a person is exposed to, the degree of exposure, the individual's health status and genetics. People who exercise outdoors, for example, on hot, smoggy days increase their exposure to pollutants in the air. The health effects caused by air pollutants may range from subtle biochemical and physiological changes to difficulty breathing, wheezing, coughing, and aggravation of existing respiratory and cardiac conditions.

- 1 **Public Health:** The effect on humans is of primary importance. The respiratory system is particularly susceptible to effects ranging from short-term discomfort to the possibility of lung cancer or pulmonary emphysema. Complications with chronic diseases, such as bronchial asthma and chronic bronchitis, arise because of air pollution. Persons suffering from heart disease are adversely affected by the increased effort required to get sufficient oxygen into the blood. Sulfur oxides and misted sulfuric acid have particularly severe effects. The health effects of all photochemical smog products have not been completely determined. They are known to irritate exposed mucous membranes, such as the eyes. Respirable  $\text{PM}_{10}$  and  $\text{PM}_{2.5}$  particulates are known to cause serious health effects among young children and the elderly.

The effect of carbon monoxide on health and performance of humans is of special concern. Under adverse weather conditions, CO will remain in the vicinity of where it was emitted for some time. Concentrations of 120 ppm, far above the standards shown in Table 30-3, have been recorded during peak hours on Los Angeles freeways. Such concentrations can impair performance of visual signal detection tasks (Ref. 7). 100 ppm of CO can cause headaches and 200 ppm can cause shortness of breath. Any situation where many vehicles idle and change speeds frequently, such as in long queues at STOP signs, can give rise to such effects.

*Smog* can cause irritation of mucous membranes and headaches and, in cases of long-term exposure, lung lesions. Smog effects may be exacerbated by the presence of  $\text{SO}_2$  and/or particulates, and are aggravated by exercise.

- 2 **Effects on Animals:** The effects on animals are similar to human effects; however, small animals are bothered more. A major concern is the cumulative effect of toxic substances, such as arsenic and lead. Ingestion of deposits on plants by foraging animals can lead to loss of productivity from illness, and even death.



- 3 **Effects on Vegetation:** The types and severity of effects on vegetation vary with different plants and the concentrations of contaminants. Leaf vegetables, grapes, and citrus fruit trees suffer loss in production and reduced growth in the presence of ozone, PANs, SO<sub>2</sub> and NO<sub>2</sub>. Trees in pine forests and on Christmas tree farms have been discolored and have experienced premature needle drop from the effects of ozone and peroxides. Flower farms near freeways have experienced severe flower damage from ethylene.
- 4 **Effects on Soil and Water Quality:** Acid rain has a wide-ranging impact on soil and water quality, the latter especially in lakes. After rainfalls containing even small amounts of sulfuric acid, the pH level of water can drop sufficiently to injure or kill aquatic life. Forests have been severely damaged.
- 5 **Effects on Materials:** Accelerated corrosion of metal is a primary effect. Building stone, marble in particular, deteriorates more rapidly due to the attack of SO<sub>2</sub>, NO<sub>2</sub>, and related acids. Paper and leather are made brittle by SO<sub>2</sub>. Rubber is severely damaged by ozone. Fabrics, both natural and synthetic, are adversely affected. Paints and similar coatings are damaged.

## H. Legislative History (Ref. 2)

In the early 1900s, concerns about air pollution led to smoke controls for industrial plants. A major result was the switching of fuel from coal to cleaner-burning oil and gas. Los Angeles County established an Air Pollution Control District in 1946. More controls followed, initiated by state and local governments.

Federal legislation began with the Air Pollution Control Act of 1955, which funded some research and technical assistance, but provided no control. Concern about interstate air pollution was addressed in the Clean Air Act of 1963. A federal program to regulate emissions from new motor vehicles (beginning with the 1968 models) was established by the Motor Vehicle Air Pollution Control Act of 1965. The Air Quality Act of 1967 extended the role of the federal government to both research and enforcement.

The Clean Air Act Amendment (CAAA) of 1970 provided the tools for enforcement: 1975 was set as the year to achieve clean air. It required the Environmental Protection Agency to establish National Ambient Air Quality Standards (NAAQSs). The states were required to submit State Implementation Plans (SIPs) for attaining these standards. Other elements include motor vehicle emissions standards, stationary source standards and permits, acid rain control measures, stratospheric ozone protection and enforcement provisions. The CAAA of 1977 designated regulations for non-attainment areas and delayed the implementation of automobile emission standards.

Realizing that air pollution had become a global concern, the CAAA of 1990 made sweeping changes. This legislation consists of 11 separate titles that address several key issues; the first two have direct impact on highway transportation. Title I applies to urban areas that were non-attainment in ozone, CO, and PM<sub>10</sub>. Title II deals with mobile sources, including regulations such as cold temperature idle emissions and fuel quality. A clean fuel car pilot program was established in California. The California Air Resources Board must certify new motor vehicles and engines for emission compliance.

In 1997, the U.S. EPA tightened the NAAQS for ozone and particulates, adding a new standard for very small particulates of 2.5 microns diameter (PM<sub>2.5</sub>) while retaining the standard for larger particulates (PM<sub>10</sub>).

## I. Ambient Air Quality Standards

U.S. and California ambient air quality standards are shown in Table 30-3.

Ambient air quality standards (AAQS) define clean air, and are established to protect even the most sensitive individuals in our communities. An air quality standard defines the maximum amount of a pollutant that can be present in outdoor air without harm to the public's health. Both the ARB and the U.S. EPA are authorized to set ambient air quality standards.

**Table 30-3—Federal and California Ambient Air Quality Standards (Ref. 8)**

<b>Ambient Air Quality Standards</b>							
Pollutant	Averaging Time	California Standards <sup>1</sup>		Federal Standards <sup>2</sup>			
		Concentration <sup>3</sup>	Method <sup>4</sup>	Primary <sup>3,5</sup>	Secondary <sup>3,6</sup>	Method <sup>7</sup>	
Ozone (O <sub>3</sub> )	1 Hour	0.09 ppm (180 µg/m <sup>3</sup> )	Ultraviolet Photometry	—	Same as Primary Standard	Ultraviolet Photometry	
	8 Hour	0.070 ppm (137 µg/m <sup>3</sup> )		0.08 ppm (157 µg/m <sup>3</sup> ) <sup>8</sup>			
Respirable Particulate Matter (PM <sub>10</sub> )	24 Hour	50 µg/m <sup>3</sup>	Gravimetric or Beta Attenuation	150 µg/m <sup>3</sup>	Same as Primary Standard	Inertial Separation and Gravimetric Analysis	
	Annual Arithmetic Mean	20 µg/m <sup>3</sup>		50 µg/m <sup>3</sup>			
Fine Particulate Matter (PM <sub>2.5</sub> )	24 Hour	No Separate State Standard		65 µg/m <sup>3</sup>	Same as Primary Standard	Inertial Separation and Gravimetric Analysis	
	Annual Arithmetic Mean	12 µg/m <sup>3</sup>	Gravimetric or Beta Attenuation	15 µg/m <sup>3</sup>			
Carbon Monoxide (CO)	8 Hour	9.0 ppm (10mg/m <sup>3</sup> )	Non-Dispersive Infrared Photometry (NDIR)	9 ppm (10 mg/m <sup>3</sup> )	None	Non-Dispersive Infrared Photometry (NDIR)	
	1 Hour	20 ppm (23 mg/m <sup>3</sup> )		35 ppm (40 mg/m <sup>3</sup> )			
	8 Hour (Lake Tahoe)	6 ppm (7 mg/m <sup>3</sup> )		—			—
Nitrogen Dioxide (NO <sub>2</sub> )	Annual Arithmetic Mean	—	Gas Phase Chemiluminescence	0.053 ppm (100 µg/m <sup>3</sup> )	Same as Primary Standard	Gas Phase Chemiluminescence	
	1 Hour	0.25 ppm (470 µg/m <sup>3</sup> )		—			
Sulfur Dioxide (SO <sub>2</sub> )	Annual Arithmetic Mean	—	Ultraviolet Fluorescence	0.030 ppm (80 µg/m <sup>3</sup> )	—	Spectrophotometry (Pararosaniline Method)	
	24 Hour	0.04 ppm (105 µg/m <sup>3</sup> )		0.14 ppm (365 µg/m <sup>3</sup> )			
	3 Hour	—		—			0.5 ppm (1300 µg/m <sup>3</sup> )
	1 Hour	0.25 ppm (655 µg/m <sup>3</sup> )		—			—
Lead <sup>9</sup>	30 Day Average	1.5 µg/m <sup>3</sup>	Atomic Absorption	—	—	—	
	Calendar Quarter	—		1.5 µg/m <sup>3</sup>			Same as Primary Standard
Visibility Reducing Particles	8 Hour	Extinction coefficient of 0.23 per kilometer — visibility of ten miles or more (0.07 — 48 km or more for Lake Tahoe) due to particles when relative humidity is less than 70 percent. Method: Beta Attenuation and Transmittance through Filter Tape.		<b>No Federal Standards</b>			
Sulfates	24 Hour	25 µg/m <sup>3</sup>	Ion Chromatography				
Hydrogen Sulfide	1 Hour	0.03 ppm (42 µg/m <sup>3</sup> )	Ultraviolet Fluorescence				
Vinyl Chloride <sup>9</sup>	24 Hour	0.01 ppm (26 µg/m <sup>3</sup> )	Gas Chromatography				

See footnotes next page...

*Footnotes for Table 30-3*

1. California standards for ozone, carbon monoxide (except Lake Tahoe), sulfur dioxide (1- and 24-hour), nitrogen dioxide, suspended particulate matter—PM<sub>10</sub>, PM<sub>2.5</sub>, and visibility reducing particles—are values that are not to be exceeded. All others are not to be equaled or exceeded. California ambient quality standards are listed in the Table of Standards in Section 70200 of Title 17 of the California Code of Regulations.
2. National standards (other than ozone, particulate matter, and those based on annual averages or annual arithmetic mean) are not to be exceeded more than once a year. The ozone standard is attained when the fourth highest eight-hour concentration in a year, averaged over three years, is equal to or less than the standard. For PM<sub>10</sub>, the 24-hour standard is attained when the expected number of days per calendar year with a 24-hour average concentration above 150 µg/m<sup>3</sup> is equal to or less than one. For PM<sub>2.5</sub>, the 24-hour standard is attained when 98% of the daily concentrations, averaged over three years, are equal to or less than the standard. Contact U.S. EPA for further clarification and current federal policies.
3. Concentration expressed first in units in which it was promulgated. Equivalent units given in parentheses are based upon a reference temperature of 25°C and a reference pressure of 760 torr. Most measurements of air quality are to be corrected to a reference temperature of 25°C and a reference pressure of 760 torr; ppm in this table refers to ppm by volume, or micro-moles of pollutant per mole of gas.
4. Any equivalent procedure which can be shown to the satisfaction of the ARB to give equivalent results at or near the level of the air quality standard may be used.
5. National Primary Standards: The levels of air quality necessary, with an adequate margin of safety to protect the public health.
6. National Secondary Standards: The levels of air quality necessary to protect the public welfare from any known or anticipated adverse effects of a pollutant.
7. Reference methods as described by the EPA. An "equivalent method" of measurement may be used, but must have a "consistent relationship to the reference method" and must be approved by the EPA.
8. New federal 8-hour ozone and fine particulate matter standards were promulgated by U.S. EPA on July 18, 1997. Contact U.S. EPA for further clarification and current federal policies.
9. The ARB has identified lead and vinyl chloride as "toxic air contaminants" with no threshold level of exposure for adverse health effects determined. These actions allow for the implementation of control measures at levels below the ambient concentrations specified for these pollutants.

---

California Air Resources Board, (5/17/06)

Ambient air is that portion of the atmosphere, external to buildings, to which the public has access. Under the 1990 Federal Clean Air Act Amendment, attainment dates vary with the severity of the pollution problem, from 1994 for "moderate" areas to 2010 for Los Angeles, the only area classified as having an "extreme" pollution problem.

## J. Vehicle Emission Standards and Control Measures

Vehicle Emission Standards are a set of performance criteria and restrictions that limit the concentrations of pollutants emitted by a source. In setting emission standards, the possible and reasonable levels of control must be considered. These levels depend on the engine design and the fuel used. The first emission controls were instituted in California in 1966. Federal emission standards were enacted in 1968. Prior to 1966, no emission standards were set, but crankcase emission devices were required. Standards for gasoline and diesel automobiles and trucks can be found in Refs. 9 and 10.

Vehicle emission tests are based on standard driving cycles that have been defined to reflect variations introduced by typical operating conditions. Since 1972, California has used a constant volume sample (CVS) test, which includes cold and hot starts. Federal emission standards are based on simulating an average 12-km trip in an urban area; the test consists of engine startups and vehicle operation on a chassis dynamometer.

Measures available to reduce automobile emission pollutants in order to achieve these standards include:

- 1 **Modifying Internal Combustion Engines**, primarily by making them smaller, by other redesign, adding new devices, and tune-up. Newer engines run at a leaner fuel/air ratio, reducing RVOC and NO emissions, and at a retarded spark ignition timing, reducing NO<sub>x</sub> emissions.

## 2 Adding Emission Controls.

- a. *Crankcase emission controls* recycle gases emitted from the oil sump into the combustion chamber.
- b. *Exhaust gas recycling* introduces a portion of the exhaust gases into the fuel/air mixture before it enters the combustion chamber, thereby reducing the emissions of  $\text{NO}_x$ .
- c. *Catalytic converters* treat exhaust gases catalytically, reducing CO, HC and  $\text{NO}_x$  concentration levels. Converters must use lead-free fuel and do not become fully operational until they are warmed up. So-called "cold start" emissions can account for 40-70% of total emissions on a typical urban trip.

## 3 Modifying Fuel Composition to burn more completely and to eliminate harmful additives – in particular, lead. Aromatic hydrocarbons or alcohols that burn smoothly are introduced in higher proportion to eliminate engine knock. Since 1996, the California Air Resources Board (CARB) has required the use of reformulated gasoline designed to reduce emissions of CO, $\text{NO}_x$ , $\text{SO}_x$ , and other species. In September 2000, Phase 3 regulations for reformulated gas became effective, prohibiting use after 2002 of the additive MTBE, which has caused concern over potential ground water pollution. (Ref. 11)

Other fuels, such as compressed natural gas, liquefied natural gas, and liquefied petroleum gas could be used. These fuels ignite easily and burn more completely than present-day gasoline. A conversion of engine fuel control systems is required.

## 4 Developing New Propulsion Systems. Cleaner propulsion systems for motor vehicles have long been suggested as the ultimate solution for mobile source air pollution. In 1990, CARB adopted a requirement that 10% of new cars offered for sale in California beginning in 2003 must be zero emission vehicles (ZEVs) (Ref. 12). In 1998, CARB allowed some manufacturers to meet the 2003 requirement partly or entirely with low emission vehicles (LEVs). In February 2000, the Board adopted a similar regulation for transit buses, requiring certain transit authorities to begin purchasing 15% ZEVs for their fleets in 2008. New propulsion technologies for ZEVs and LEVs include:

- a. *Battery-power.* The best battery systems currently available provide performance (acceleration, hill climbing, maximum speed) comparable to the internal combustion engine; however, unless used in a hybrid technology, batteries have less capability (total work capacity and range). In-use pollution would be virtually eliminated, but production of additional power for large fleets of electric vehicles could create new stationary source pollution.
- b. *Fuel cells.* Impressive advances in fuel cell technology have recently been made. Fuel cell-powered buses are currently serving passengers in public demonstration programs in several North American cities. Pollutant emissions are negligible.
- c. *External combustion engines.* Both the steam engine and the Stirling engine compare favorably with the reciprocating internal combustion engine in capability. However, the performance of small units is not high. Large experimental external combustion power plants installed in buses have shown low emissions.
- d. *Other internal combustion engines.* The stratified-charge engine (see also Chap. 32, Sec. C.1.) is claimed to burn fuel more completely, thus lowering emissions. Gas turbine and rotary engines have power and range characteristics similar to reciprocating engines. Both seem to have better emission characteristics. The gas turbine produces fewer emissions than those anticipated for spark ignition internal combustion engines in the immediate future. The rotary (Wankel) engine has inherently high HC emission levels, moderate CO levels and low  $\text{NO}_x$  emissions. Emission control devices, such as the exhaust manifold reactor, are effective in reducing the HC and CO emissions.

## K. Transportation Planning, Conformity, and Modeling

### 1 Conformity. Federal and California laws require consideration of transportation control measures as strategies to meet air quality goals. In particular, the 1990 CAAA and the 1991

ISTEA legislation imposed Transportation Conformity requirements intended to prevent states and regions from implementing transportation projects and other actions inconsistent with their need to attain the NAAQSs. (Refs. 13 - 16) Detailed federal regulations were issued in 1993, amended in 1995 and 1997, and affected by a Federal Court of Appeals decision in March 1999. The most recent amendments were made to these regulations in 2004.

Transportation conformity is required by the Clean Air Act section 176(c) (42 U.S.C. 7506(c)) to ensure that federal funding and approval are given to highway and transit projects that are consistent with ("conform to") the air quality goals established by a state air quality implementation plan (SIP). Conformity, for the purpose of the SIP, means that transportation activities will not cause new air quality violations, worsen existing violations, or delay timely attainment of the national ambient air quality standards. The conformity process is illustrated in Fig. 30-1.

Conformity, which applies to non-attainment metropolitan areas, requires that each Metropolitan Planning Organization (MPO) must have transportation plans in place that present a 20-year perspective on transportation improvements and investments for its region. The transportation improvement program (TIP) is a multi-year prioritized list of projects (3 years at a minimum) proposed to be funded or approved by FHWA or FTA. The TIP must be consistent with the conforming transportation plan, and the TIP must be found to conform to the SIP. Specifically, the transportation plan and the TIP must result in emissions consistent with those allowed in the SIP. (Ref. 14)

Regionally significant transportation projects that are not funded or approved by FHWA or FTA, but which are sponsored by traditional recipients of FHWA/FTA funds, must also be included in the plan and TIP conformity analysis. In rural non-attainment or maintenance areas, the state must ensure that regionally significant projects conform to the SIP.

- 2 **Emissions Modeling.** Since the 1970s, extensive research and testing has been conducted in efforts to quantify more accurately the impacts on air quality from proposed transportation policies and projects, and changing traffic conditions. The U.S. EPA has sponsored the development of the Mobile Source Emissions Factor Model known as MOBILE, the current update of which is its 6th major revision (Ref. 17). In parallel, the California Air Resources Board has sponsored the development of the EMFAC (Emission FACTor) series of models (Refs. 18 and 19). The current version of EMFAC is EMFAC2002.

Both the MOBILE and EMFAC models share some common attributes differing in their focus on either the federal motor vehicle fleet (in the case of MOBILE) or the California motor vehicle fleet as in the case of EMFAC. The models share similar features in terms of pollutants considered, nature of the vehicle fleet, and the activity data necessary (either user-provided or defaults provided in the model). Below, taken from the EMFAC User's Guide (Ref. 20) is a summary of the data on pollutants, fleet characteristics, and vehicle activity necessary to generate inventories of emissions from highway motor vehicles.

- a. *Pollutants.* The model calculates emission factors and emission inventories for the following primary pollutants:
- Hydrocarbons (HC). HC can be expressed as TOG (total organic gases), ROG (reactive organic gases), THC (total hydrocarbon), or CH<sub>4</sub> (methane). The THC class includes compounds with H and C atoms only, carbonyls and halogens are not included in the class. The TOG class includes all organic gases emitted into the atmosphere. The ROG class is the same as EPA's VOC (volatile organic compounds) definition and does not contain compounds exempt from regulation.
  - Carbon monoxide (CO).
  - Nitrogen oxides (NO<sub>x</sub>).
  - Carbon dioxide (CO<sub>2</sub>).
  - Particulate matter (PM). PM estimates are provided for total suspended particulate, particulate matter 10 microns or less in diameter (PM<sub>10</sub>), and particulate matter 2.5 microns or less in diameter (PM<sub>2.5</sub>).

### Transportation Conformity Process

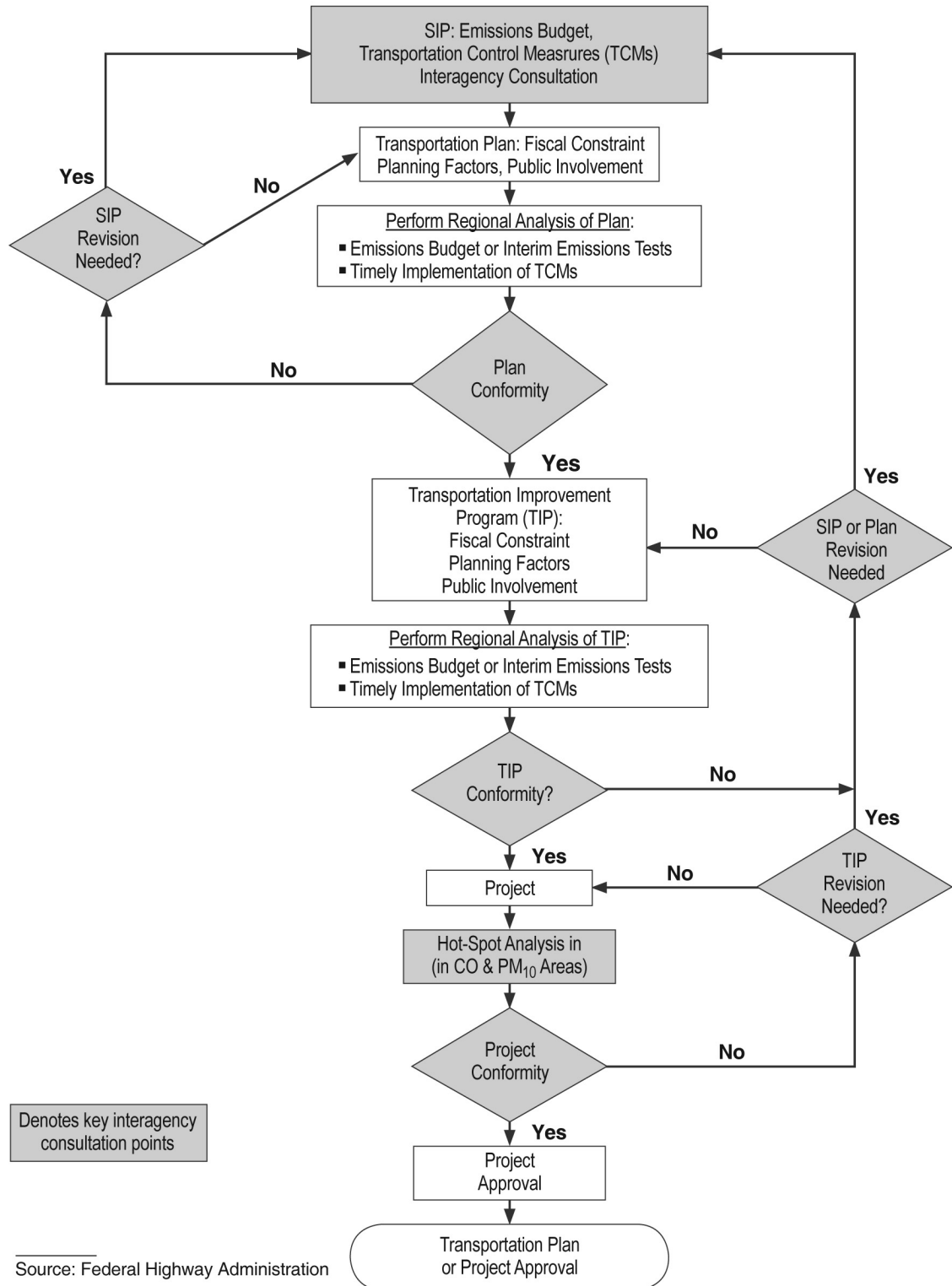

Fig. 30-1—The Transportation Air Quality Conformity Process (Ref. 14)

- Fuel consumption. Although not a pollutant, fuel consumption is calculated based on the emissions of CO, CO<sub>2</sub> and THC using the carbon balance equation.
- Oxides of sulfur (SO<sub>x</sub>). Emissions of oxides of sulfur are a function of the sulfur content of fuel. The model calculates these emissions by multiplying the fuel consumption by the weight fraction of sulfur in a gallon of fuel.
- Lead (Pb). Lead emissions are also a function of the lead content in fuel. Hence, the model calculates lead by multiplying the fuel consumption by the number of grams of lead per gallon.

Note: Lead in fuel was phased out in 1992, so lead results will be zero for 1992 and later.

- b. *Emission Processes* (Ref. 19). Emissions (especially HC) emanate from a vehicle during all hours of the day. The magnitude of these emissions varies with what is happening to the vehicle. Was the vehicle just started, is it running on the road, is it idling at a loading zone or just sitting outside in the sun? An emissions process is tied to the vehicle diurnal activity such that all emissions are accounted for during normal daily activity. The types of emission processes are:
- Running exhaust—emissions that come out of the vehicle tailpipe while it is traveling on the road.
  - Idle exhaust—tailpipe emissions while the vehicle is operating but not traveling any significant distance. This process captures emissions from heavy-duty vehicles that idle for extended periods while loading or unloading goods. Idle exhaust is only calculated for heavy-duty trucks.
  - Starting exhaust—tailpipe emissions that occur as a result of starting a vehicle. These emissions are independent of running exhaust emissions and can be thought of as a slug of emissions associated with starting a vehicle. The magnitude of these emissions is dependent on how long the vehicle has been sitting prior to starting. (Starting emissions are only estimated for gasoline-fueled vehicles).
  - Diurnal—HC emissions that occur when rising ambient temperatures cause fuel evaporation from vehicles sitting throughout the day. These losses are from leaks in the fuel system, fuel hoses, connectors, and as a result of breakthrough of vapors from the carbon canister. If a vehicle is sitting for a period of time, emissions from the first 35 minutes are counted as hot soak and emissions from the remaining period are counted as diurnal emissions, provided that the ambient temperature is increasing during the remaining period of time.
  - Resting loss—these losses occur while the vehicle is sitting and are caused by fuel permeation through rubber and plastic components. Emissions are counted as resting loss emissions if the vehicle has not been operated for 35 minutes and the vehicle is still stationary, but the ambient temperature is either constant or decreasing.
  - Hot soak—evaporative HC emissions that occur immediately after a trip end due to fuel heating and the fact that the engine remains hot for a short time after being switched off. In older, carbureted vehicles these emissions are attributed to vapor losses from the carburetor float bowl. In newer, fuel-injected vehicles, these vapor losses come from leaky fuel injectors or from fuel hoses.
  - Running losses—evaporative HC emissions that occur when hot fuel vapors escape from the fuel system or overwhelm the carbon canister while the vehicle is operating.
  - Tire wear—particulate matter emissions from tires as a result of wear.
  - Brake wear—particulate matter emissions from brake use.

The following briefly introduces terminology and concepts that model users need to understand, such as vehicle class, fuel type, and vehicle activity. This is important because the model outputs provide breakdowns of emissions by vehicle class and fuel type.

- c. *Vehicle class*. The "vehicle fleet" refers to all motor vehicles operating on roads in California. This fleet as currently modeled is sorted into 13 classes (e.g., class 1 is passenger cars).

These classes are based on the type of vehicle, but they also take weight class and fuel type (i.e. gas, diesel, or electric) into account. The number of vehicles in each class is based on an analysis of Department of Motor Vehicles (DMV) registration data. These vary by calendar year and geographic area, so the make-up of the vehicle fleet is dependent on these two factors.

The model performs separate calculations for each of the 13 classes of vehicles, by fuel usage and each technology group. Each vehicle class contains numerous technology groups, which represent common emissions characteristics such as emission standards, technologies, or in-use emissions. The vehicle classes currently modeled are shown in Table 30-4, along with abbreviations used in the model.

- (1) Fuel: Emfac2001 currently estimates emissions from gasoline, diesel and electrically powered vehicles. Table 30-4 shows the fuels modeled by vehicle class.

**Table 30-4 Vehicle Classes Modeled In Emfac2001**

Vehicle Class	Fuel Type	Code	Description	Weight Class	Abbr.
1	All*	PC	Passenger Cars	All	LDA
2	All*	T1	Light-Duty Trucks	0-3750	LDT1
3	Gas, Diesel	T2	Light-Duty Trucks	3751-5750	LDT2
4	Gas, Diesel	T3	Medium-Duty Trucks	5751-8500	MDV
5	Gas, Diesel	T4	Light-Heavy-Duty Trucks	8501-10000	LHDT1
6	Gas, Diesel	T5	Light-Heavy-Duty Trucks	10001-14000	LHDT2
7	Gas, Diesel	T6	Medium-Heavy-Duty Truck	14001-33000	MHDT
8	Gas, Diesel	T7	Heavy-Heavy-Duty Trucks	33001-60000	HHDT
9	Gas, Diesel	T8	Line-Haul Vehicles	60001+	LHV
10	Diesel	UB	Urban Buses	All	UB
11	Gas	MC	Motorcycles	All	MCY
12	Gas, Diesel	SB	School Buses	All	SBUS
13	Gas, Diesel	MH	Motor Homes	All	MH

\* gas, diesel, and electric

- (2) Technology group: The underlying assumption in Emfac2000 and Emfac2001 is that each vehicle class can be modeled by the individual behavior of unique technology groups. Each technology group represents vehicles from the same class but with distinct emission control technologies, which have similar in-use deterioration rates and respond the same to repair. A technology group can represent vehicles whose emissions standards are the same or those that have specific equipment installed on them (e.g., multi-port fuel injection, three-way catalyst, adaptive fuel controls, etc.), making them behave the same.
- (3) Model year: Emfac2001 contains emission factors and vehicle activity data for model years 1965 through 2040. Within each vehicle class, the model year is represented by a combination of technology groups. For example, a non-catalyst gasoline-fueled technology group (TG-1) and a diesel-fueled technology group (TG-170) represent the 1965 model year for passenger cars.
- d. *Activity.* An emission inventory is simply a product of the emission rates (in grams per mile or grams per trip or grams per vehicle) and vehicle activity (miles per vehicle or number of trips or total number of vehicles). This requires estimates of vehicle population, vehicle miles traveled and trips for each vehicle class, by fuel type and geographic area. These terms are commonly referred to as vehicle activity.
- (1) Vehicle population is determined through an analysis of DMV data. These data are used in developing vehicle age matrices for base years 1997 and 1998 for vehicle class, fuel type, geographic area, and vehicle ages 1 to 45 years. These matrices contain actual population estimates, which are used to back-cast and forecast vehicle populations for calendar years 1970 to 2040.



- (2) Vehicle miles traveled (VMT) represents the total distance traveled on a weekday. Local planning agencies have developed regional transportation models, which output regional VMT for certain planning years. In the Emfac2001 model, VMT is calculated based on vehicle population and vehicle accrual. Vehicle accrual is the total number of miles a vehicle accumulates in a year, and varies by vehicle age. The regional estimates of VMT are matched by modifying either or both the vehicle population and accrual estimates.

The model also contains hourly distributions of VMT by vehicle class. These distributions are based on instrumented vehicle activity data.

- (3) The number of trips or starts per day is the same, and the terms can be used interchangeably. Both represent the number of separate trips made per weekday. In Emfac2000 and Emfac2001, the estimates for trips per day for vehicle classes 1 to 4 are based on travel surveys and vehicle instrumented data. These data show that trips per day decrease linearly with vehicle age from 6.56 at age 1 to 3.72 at age 45. The trips per day estimate for other vehicle classes are based on either instrumented data or an engineering judgment. The model calculates the total number of trips for a given calendar year, region and vehicle class by summing the product of model year populations and trips per day estimates.

These highly evolved models are currently based on emissions measured from standard driving cycles (Sec. J). On occasion, they have been pressed into service to address localized issues, such as the emissions consequences of installing ramp meters along a freeway corridor. It is widely recognized that the current emissions models, reflecting aggregate driving cycles, cannot accurately predict the impacts of site-specific operational changes. Alternative methodologies, including driving mode-based emission factors, are under development.

## L. The Congestion Mitigation and Air Quality Improvement Program

(CMAQ) (Ref. 21)

The CMAQ program, introduced in ISTEA, is designed to reduce undesirable environmental impacts of motor vehicles and to make positive improvements in air quality. CMAQ provides flexible funding to attack air pollution both through traditional efforts in traffic flow and transit improvements and through new and effective projects focusing on vehicles and fuels. CMAQ funds may only be used in current or previous non-attainment areas for projects likely to contribute to achieving or maintaining the NAAQSs.

Eligible projects may pursue attainment of NAAQSs through reductions in VKT, fuel consumption, or other factors. Eligible Transportation Control Measures (TCM) are listed in Ref. 22. Funded projects have included:

- Establishment of inspection and maintenance programs,
- Conversion of public fleets to cleaner fuels,
- Purchase of electric vehicles to eliminate cold-start problems at park-and-ride lots,
- Establishment and expansion of shared-ride services,
- Promotion of TDM (see Chap. 34),
- Support for bicycle and pedestrian travel.

The effort to refocus the transportation planning process toward intermodalism has proven successful during the first few years of the program. The program has also encouraged non-traditional transportation groups to be active participants in planning.

## M. Other References

Numerous valuable references are available. The following list provides a variety of information on technical details, policies, legal aspects, practical applications, and measurement/predicting models.

- Technical (Refs. 2 and 23.)
- Policy and legal (Refs. 9, 22, and 24.)
- Applications and models (Refs. 3, 18, 19, and 25.)

#### REFERENCES

1. Parker, T. *The Land Use - Air Quality Linkage; How Land Use and Transportation Affect Air Quality*. 1997 Ed.. Sacramento, CA: California Air Resources Board, Transportation Strategies Group, 1997. 31 p. On-line. Internet. Nov. 2004. Available: <http://www.arb.ca.gov/ch/programs/linkage.htm>.
2. Cooper, C.D. and F.C. Alley. *Air Pollution Control, A Design Approach*. Third Edition, Prospect Heights, IL: Waveland Press, Inc. 2002, 760 p.
3. U.S. EPA Technology Transfer Network Clearinghouse for Inventories and Emission Factors. On-line. Internet November 2004. Available: <http://www.epa.gov/ttn/chief/trends/index.html>.
4. National Research Council, Committee on Motor Vehicle Emissions. *Report by the .Committee on Motor Vehicle Emissions*. Washington, DC: Nov. 1974.
5. Legarra, J.A. "Air Pollution Studies." *Ca. Division of Highways Circular Letter*. Sacramento, CA: April 21, 1970.
6. Marks, C., and G. Niepoth. "Car Design for Economy and Emissions." *Automotive Fuel Economy*. Warrendale, PA: Society of Automotive Engineers. Progress in Technology Series, v. 15, 1976. pp. 134-158.
7. Stokols, D., and R. W. Novaco. "Transportation and Wellbeing: An Ecological Perspective." In: Altman, Irvin (ed.). *Transportation and Behavior*. New York and London: Plenum Press, 1981, pp. 91-92.
8. California Air Resources Board. Ambient Air Quality Standards, May 2006. On-line. Internet. October 2006. Available: <http://www.arb.ca.gov/aqs/aaqs2.pdf>.
9. U.S. Government. *Code of Federal Regulations*. Title 40, Part 86. Updated annually.
10. DieselNet. *Emission Standards: United States. Cars and Light-Duty Trucks*. (Includes California Standards.) On-Line. Internet, Oct. 2006. Available: <http://www.dieselnets.com/standards/us/light.html>.
11. California Air Resources Board. *California Reformulated Gasoline Phase 3 Amendments*. Sacramento, CA. On-line. Internet. November 2004. Available: <http://www.arb.ca.gov/regact/carfg3/carfg3.htm>.
12. California Air Resources Board. *Zero-Emission Vehicle Program*. Sacramento, CA. On-line. Internet. November 2004. Available: <http://www.arb.ca.gov/msprog/zevprog/zevprog.htm>.
13. U.S. Environmental Protection Agency, Transportation and Air Quality Planning Guidance Documents On-line, Nov. 2004: <http://www.epa.gov/OMSWWW/transp/traqconf.htm>.
14. U.S. FHWA. *Transportation Conformity: A Basic Guide for State and Local Officials*. Washington, DC: On-line. Internet. Nov. 2004: [http://www.fhwa.dot.gov/environment/conformity/ref\\_guid/index.htm](http://www.fhwa.dot.gov/environment/conformity/ref_guid/index.htm).
15. Howitt, Arnold M. and Elizabeth M. Moore. "Implementing the Transportation Conformity Regulations." TR News. Number 202. Washington DC: Transportation Research Board, May-June 1999.
16. Anderson, J.P. and A.M. Howitt. "Clean Air Act, SIPs, Sanctions and Conformity." *Transportation Quarterly*, v. 49, n. 3. Summer 1995, pp. 67-79.
17. Committee to Review EPA's MOBILE Model. *Modeling Mobile-Source Emissions*. Transportation Research Board. Washington DC: National Academy Press. 2000. On-line. Internet. November 2004. Available: <http://books.nap.edu/openbook/0309070880/html/R1.html>.

18. California Air Resources Board. *Methodology for Estimating Emissions from On-road Motor Vehicles*. Sacramento, CA: Technical Support Division, Mobile Source Inventory Branch. 7 volumes. October–November 1996.
19. California Air Resources Board. Mobile Source Emissions Inventory. On-line. Internet. November 2004. Available: <http://www.arb.ca.gov/msei/on-road/briefs/emfac7.pdf>.
20. California Air Resources Board. EMFAC 2001/EMFAC 2002: *Calculating Emission Inventories for Vehicles in California - User's Guide*. 2003. Available on-line at: [http://www.arb.ca.gov/msei/on-road/previous\\_version.htm](http://www.arb.ca.gov/msei/on-road/previous_version.htm) (accessed Sept. 2004).
21. Savonis, M.J. "The CMAQ Program: Realizing ISTEA's Promise." *Public Roads*. Washington, DC: U.S. Department of Transportation. Spring 1995, pp. 7–8.
22. U.S. Code, Title 42, Section 7408 (f)(1).
23. Boubel, R.W., D.L. Fox, D.B. Turner, and A.C. Stern. *Fundamentals of Air Pollution*. Third Edition. San Diego, CA: Academic Press. 1994, 574 p.
24. Reitze, A.W. Jr. "Federal Air Quality Laws Governing State and Regional Transportation Planning." *NCHRP Legal Research Digest 31*. Washington DC: Transportation Research Board. Dec. 1994, 31 p.
25. Deakin, Harvey, Skabardonis, Inc. *Manual of Regional Transportation Modeling Practice for Air Quality Analysis*. Washington DC: The National Association of Regional Councils, 1993. On-line. Internet. November 2004. Available: <http://tmip.fhwa.dot.gov/clearinghouse/docs/airquality/mrtm/>.

### A. General

"Highway traffic noise seriously impacts more people than virtually any other source of environmental noise." (Ref. 1, p. 48.1) "Noise is a problem of continuing public concern." (Ref. 2, p. 1)

- 1 Although maximum sound levels are not increasing, traffic noise is continuously invading previously quiet places and is prevalent during more hours per day.
- 2 The two aspects of the problem are noise perceived by vehicle occupants and noise perceived by persons in the vicinity of the highway.
- 3 Some forms of traffic noise have positive effects—e.g., horns and sirens to warn of approaching vehicles or rumble strips to give audible warnings to drivers of potentially hazardous situations. The current trend to reduce noise in vehicle interiors may be counterproductive to the effectiveness of these warnings.

Noise emitted by a vehicle is used by pedestrians, especially those with sight impairment, to judge its location and often its speed. Electric or solar-powered cars and light rail vehicles can be so quiet that they may present a hazard to certain pedestrians. Research is needed to determine if the negative effects of such noise reduction could become significant.

### B. Definitions

- 1 **Noise.**
  - a. Unwanted sound.
  - b. Any sound not occurring in the natural environment, such as emanating from aircraft, highways, or industrial, commercial, and residential sources.
- 2 **Sound.** Energy transmitted through air or other elastic media by oscillating waves and/or particle vibrations.
- 3 **Sound Power** (W). The total sound energy radiated by a source per unit time (Watt).
- 4 **Sound Intensity** (I). The sound energy flow through a unit area in a unit of time ( $W/m^2$ ).
- 5 **Sound Pressure** (P). The instantaneous difference between the actual pressure in a sound wave and the ambient (barometric) pressure at a given point in space (Pascals—Pa;  $1 Pa = 1 \text{ Newton}/m^2$ ).
  - a. Since the pressure in a sound wave is continuously varying, average, or root-mean-square, pressure is usually measured.
  - b. For ideal conditions sound pressure is proportional to the square root of sound intensity.

- 6 **Frequency.** Sound energy is emitted in different frequencies (pitches), which is the rate of repetition of a sine wave of sound, measured in hertz (Hz) units, where 1 Hz = 1 cycle per second. The ear has a different sensitivity to different frequencies, with the greatest sensitivity in the range of 3000–4000 Hz.
- 7 **Frequency Weighting.** There are methods to account for changes in sensitivity as a function of frequency. The A-weighting system (dBA) is typically used during sound measuring procedures in an effort to simulate the relative response of the human ear.
- 8 **Loudness.** This is the subjective judgment by humans of the intensity of a sound. Loudness depends upon the sound pressure and frequency of the stimulus. Over much of the frequency range it takes about a threefold increase in sound pressure to produce a doubling of loudness.
- 9 **Decibels (dB).** Used as an objective measure of perceived noise, the decibel is a logarithmic unit which expresses the ratio of the sound pressure level being measured to a standard reference level. Because loudness is perceived in proportion to the logarithm of sound intensity, the intensity level (IL) is expressed as:

$$IL = 10 \log(I / I_0) dB \tag{31.1}$$

where  $I_0 = 10^{-12} W / m^2$

[NOTE: All logs in this chapter are to the base 10.]

Since sound pressure under ideal conditions is proportional to the square root of intensity, the decibels for pressure levels (L) can be written as:

$$L = 10 \log(P / P_0)^2 = 20 \log(P / P_0) dB \tag{31.2}$$

- 10 **Sound Pressure Level.** The sound pressure in decibels is related to a specified reference pressure ( $P_0$ ), that is usually taken to be the approximate threshold of human hearing (20µPa). Therefore,  $L = 20 \log (P/20 \cdot 10^{-6})$ . This defines a unit for measuring sound pressure. Examples of sound pressure levels are given in Table 31-1.

**Table 31-1—Examples of Sound Pressure Levels**

Sound Pressure (dBA)	Source of Sound	General Evaluation of Noise
0		Threshold of hearing (2000 Hz)
10	Rustle of leaves	
20	Whisper	Very quiet
60	Conversation at 2 m	Quiet
70	Vacuum cleaner	
80	Garbage disposal unit	Moderately loud
90	Compressor at 15 m	
100	Jet fly-over at 300 m	Very loud
110	Jet take-off at 300 m	
120	Loud thunder, jackhammer at 1.5 m	Uncomfortably loud
130		Painful sound
140		Permanent damage

- 11 **Equivalent Sound Pressure Level ( $L_{eq}$ ).** A steady-state sound level that contains the same amount of acoustic energy as the actual time-varying sound level over a specified period of time (typically 1 hour).
- 12 **Decibel Arithmetic.** Since decibels are logarithmic units, sound levels cannot be added by arithmetic means. The following equations illustrate these logarithmic principles.

a. *Comparing Sound Pressure Levels.*

If  $L_1 = 20 \log(P_1/P_0)$  dB and  $L_2 = 20 \log(P_2/P_0)$  dB,  
then  $L_2 - L_1 = 20 \log(P_2/P_1)$  dB.

b. *Multiplying Sound Pressure.*

If  $L_2$  is the pressure level when  $L_1$  (from 12 a. above) is multiplied by a constant  $K$ :  
then  $L_2 = 20 \log(KP_1/P_0) = 20 \log(P_1/P_0) + 20 \log(K)$  dB =  $(L_1 + 20 \log(K))$  dB.

c. *Adding Sound Pressure Levels from Several Sources.*

Only sound intensities can be added directly. To add sound pressure levels,  $L_1$  and  $L_2$ , from two sources, the following formula is necessary:

$$L = 10 \log [\text{Antilog}(L_1/10) + \text{Antilog}(L_2/10)] \text{ dB} \quad [31.3]$$

As an example, if  $L_1 = 55.0$  dB and  $L_2 = 47.0$  dB, then  $L = 55.6$  dB. This example shows that the maximum sound pressure level source tends to dominate.

Table 31-2 summarizes typical rules for combining sound level.

**Table 31-2—Rules for Combining Sound Levels by "Decibel Addition"**

For noise levels known or desired to an accuracy of $\pm 1$ decibel (acceptable for traffic noise analysis)	
When two decibel values differ by	Add this amount to the higher value
0 or 1 dB	3 dB
2 or 3 dB	2 dB
4 to 9 dB	1 dB
10 dB or more	0

Source: Ref. 3

### C. Effects of Traffic Noise

- Task Performance.** Traffic noise can most commonly affect speech communications. Effect on mental and physical tasks is very little except when there are sudden, distracting peaks.
- Sleep.** Noise of sufficient intensity causes difficulty in going to sleep, sleeping more lightly, and even awakening.
- Physiological Effects.** It has not been proven that traffic noise has a long-term effect on hearing although slight, temporary impairment has been noticed. Physiological fright reactions might have a cumulative harmful effect.
- Subjective Effects.** People vary greatly in what they consider an annoying noise level, depending on such factors as past experience, adaptation, type of noise, attitudes towards the source of noise, and the activity of the listener. Peaking characteristics are as important as average levels.

### D. Sources of Traffic Noise

Noise in general comes from inefficiency in the conversion of energy.

- Exhaust Systems** are responsible for most noise from trucks and automobiles when traveling under 50 km/h.
- Road-Tire Interaction** is the main component of noise from trucks and automobiles traveling at or over 80 km/h. This noise results from tire carcass vibration and from entrapment and release of air from tread cavities. It is a function of pavement type and texture, tire conditions, and speed.

Speeds between 50 and 80 km/h are in a transition zone where the type of vehicle is a prominent factor in determining which source emits the predominant noise.

- 3 **Engine Noise** results from vibrations, from moving parts, and from the part of combustion that is not channeled through the exhaust system. The amount of noise emitted is a function of engine revolutions per minute (rpm).
- 4 **Aerodynamic Noise** from the interaction of vehicles with the air is insignificant outside the vehicle, but can be disturbing to vehicle occupants.
- 5 **Other Noise Sources** include brakes, gear boxes, engine air intakes, squealing tires, horns, sirens, cargo rattling, loud radios, and the closing of doors, hoods, and trunks.

## E. Factors Affecting Traffic Noise Level

Several factors play a role in the level of noise that is perceived by the receiver. Detailed information on the amount of impact of each of these factors can be found in Ref. 4.

- 1 **Vehicle Types:** The type of vehicle being considered will have an impact on all sources of noise. Below are generally accepted definitions of five major classes of vehicle types; the emission levels are illustrated in Fig. 31-1.

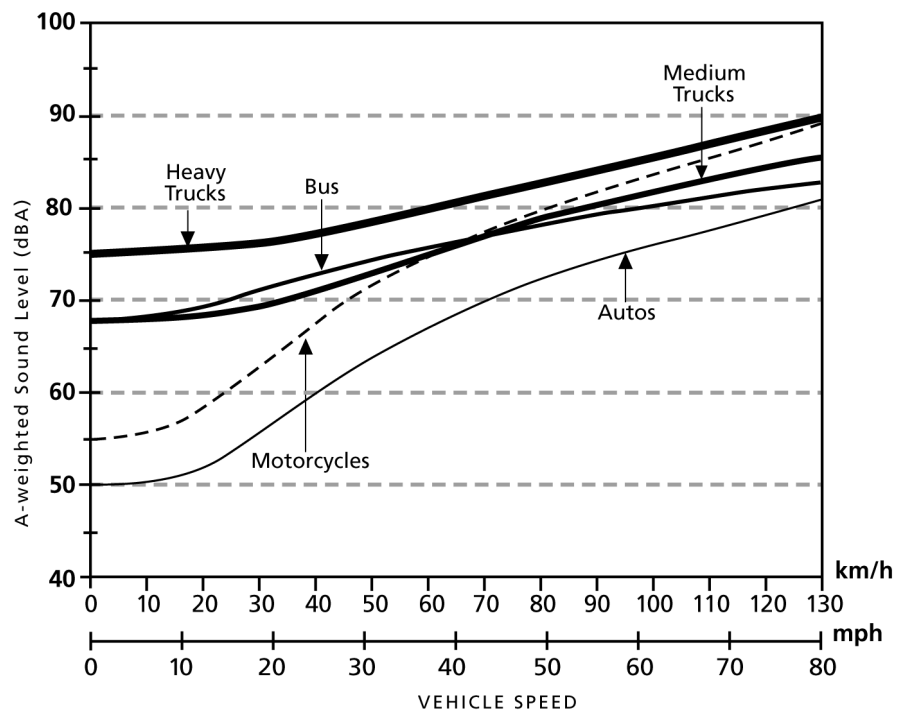

Source: Ref. 4.

**Fig. 31-1—A-Weighted Noise Emissions by Vehicle Type  
Cruise Throttle, Average Pavement**

- a. *Automobiles*: vehicles having 2 axles and 4 tires, designated primarily for transportation of 9 or fewer passengers or light cargo. Generally, gross vehicle weight (GVW) less than 4500 kg.
- b. *Medium Trucks*: cargo vehicles with 2 axles and six tires. Generally, GVW between 4500 and 12,000 kg.
- c. *Heavy Trucks*: cargo vehicles with 3 or more axles. Generally, GVW greater than 12,000 kg.
- d. *Buses*: vehicles having 2 or 3 axles, designated for transportation of more than 9 passengers.
- e. *Motorcycles*: vehicles with 2 or 3 tires with an open-air driver or passenger compartment.

Ref. 5 suggests the following simplified formulae for the reference energy mean emission level for the first three vehicle types, where S is the average speed of the vehicle class in km/h:

$$\text{Automobiles:} \quad (\bar{L}_0)_{E_A} = 38.1 \log(S) - 2.4 \quad [31.4a]$$

$$\text{Medium trucks:} \quad (\bar{L}_0)_{E_{MT}} = 33.9 \log(S) + 16.4 \quad [31.4b]$$

$$\text{Heavy trucks:} \quad (\bar{L}_0)_{E_{HT}} = 24.6 \log(S) + 38.5 \quad [31.4c]$$

In the mid 1980s, a similar set of equations was determined with automobiles having slightly higher noise levels and trucks having slightly lower levels (Ref. 6).

Ref. 1, Chap. 48, gives different formulae, some of which separate the noise produced by tires from that produced by propulsion systems.

- 2 **Traffic Speed and Volume.** The volume and speed of traffic will primarily affect the amount of noise that is produced from exhaust systems and tire-pavement interaction as well as overall noise levels.
- 3 **Throttle/Acceleration.** Whether a vehicle is accelerating or cruising affects the amount of noise produced from exhaust systems and engine compartments. Increasing roadway grades and multiple traffic control devices can increase noise by lengthening the time the vehicle is in acceleration.
- 4 **Distance to Source.** The distance from the source of noise to the receiver (e.g., from a vehicle to a house) has a significant impact on the noise level at the receiver site.
- 5 **Other Factors.** Other factors that affect the level of noise at the receiver include the type of terrain and vegetation, obstacles between the source and the receiver, and pavement type and condition.

## F. Measuring Traffic Noise

Three dimensions of obtaining sound measurement are determining sound pressure level, frequency characteristics, and time variations.

- 1 **Sound Pressure Level** can be measured using a sound meter. Most meters are adjustable to allow the user to select the rate at which readings are taken. Typical options include fast, slow, and impulse.
- 2 **Frequency Characteristics.** Special attachments can be used with sound meters to study the energy in different frequency ranges. It is more common to use a frequency weighting network, which is included in most sound meters. Of the three weighting networks, A, B, and C, the A-network is most commonly used for traffic and environmental measuring.
- 3 **Time Variation.** Traffic noise is continuously varying in pressure level, its most conspicuous features being a background level and intermittent peaks. The hourly equivalent sound pressure level ( $L_{eq}$ ) is most commonly used in noise studies to provide a reasonable comparison of sound pressure levels at different receptor locations. Other time-dependent sound pressure level measurements used for comparison include:

$L_{10}$  - the sound pressure level exceeded 10% of the time.

$L_N$  - the sound pressure level exceeded N% of the time.

$L_{max}$  or  $L_{min}$  - the maximum or minimum weighted sound pressure level in a given period.



## G. Estimating Road Traffic Noise

Detailed procedures for estimating road traffic noise by manual, nomographic, programmable calculator, and computer program methods can be found in Refs. 1-2 and 7-12 at the end of this chapter. The FHWA Highway Traffic Noise Prediction Model (Ref. 5) arrives at a predicted noise level through a series of adjustments to a reference sound level. This reference level is the energy mean emission level. Adjustments are made to account for traffic flows, for varying distances from the roadway, for finite length roadways, and for shielding. These variables are related by the following equation:

$$\begin{aligned}
 L_{eq}(h)_1 &= (\bar{L}_0)_{E_i} && \text{reference energy mean emission level} \\
 &+ 10 \log \left( \frac{N_i \pi D_0}{S_i T} \right) && \text{traffic flow adjustment} \\
 &+ 10 \log \left( \frac{D_0}{D} \right)^{1+\alpha} && \text{distance adjustment} \\
 &+ 10 \log \left( \frac{\psi_\alpha(\phi_1, \phi_2)}{\pi} \right) && \text{finite roadway adjustment} \\
 &+ \Delta_s && \text{shielding adjustment}
 \end{aligned} \tag{31.5}$$

where:  $L_{eq}(h)_i$  = the hourly equivalent sound level of the  $i$ th class of vehicles.

$(\bar{L}_0)_{E_i}$  = the reference energy mean emission level of the  $i$ th class of vehicles (Eq. [31.4]).

$N_i$  = the number of vehicles in the  $i$ th class passing a specified point during some specified time period (1 hour).

$D$  = the perpendicular distance, in meters, from the centerline of the traffic lane to the observer.

$D_0$  = the reference distance at which the emission levels are measured. In the FHWA model,  $D_0$  is 15 m.  $D_0$  is a special case of  $D$ .

$S_i$  = the average speed of the  $i$ th class of vehicles, measured in km/h.

$T$  = the time period over which the equivalent sound level is computed (1 hour).

$\alpha$  = a site parameter whose value depends on site conditions. For "hard" acoustical (reflective) sites,  $\alpha = 0$ ; for "soft" (absorptive) sites,  $\alpha \approx 0.5$ .

$\Psi$  = a function used for segment adjustments, i.e., an adjustment for finite length roadways.

$\phi_1, \phi_2$  = angles between the perpendicular drawn from the observer to the roadway segment and the left and right ends of the segment respectively.

$\Delta_s$  = the attenuation, in dB, provided by some type of shielding such as barriers, rows of houses, densely wooded areas, etc.

The first two lines in Eq. [31.5] predict the equivalent sound level generated by a flow of vehicles of a single class traveling at a constant speed on an effectively infinite, flat roadway at a reference distance of 15 m. The last three lines of the equation represent adjustments that deal with the site conditions between the observer and the roadway.

Once the  $L_{eq}(h)_i$  values have been computed, the total hourly equivalent sound level  $L_{eq}(h)$ —the sum of the acoustic contributions of the various classes of vehicles on the roadway—can be obtained by Eq. [31.6].

$$L_{eq}(h) = 10 \log \left( 10^{\frac{L_{eq}(h)_A}{10}} + 10^{\frac{L_{eq}(h)_{MT}}{10}} + 10^{\frac{L_{eq}(h)_{HT}}{10}} + 10^{\frac{L_{eq}(h)_{BT}}{10}} + 10^{\frac{L_{eq}(h)_{McT}}{10}} \right) \quad [31.6]$$

To calculate  $L_{10}(h)$ , adjust this equation by substituting  $L_{10}(h)_i$  for each  $L_{eq}(h)_i$ . The total  $L_{10}(h)$  is computed by logarithmically summing the contribution from each class in the same manner as shown for  $L_{eq}(h)$  in Eq. [31.6]. For details of this method of estimating traffic noise, consult Ref. 5.

An updated version of the FHWA model is available (Ref. 4). This version has more detailed and complex equations to estimate  $L_{eq}$  levels and can account for all factors discussed in Part E.

"A few general relationships may be helpful in understanding some of the principles of sound generation and human response. A doubling of the traffic volume at the source produces a 3 dBA increase in the sound level. [Doubling  $N_i$  in Eq. 31.5 increases  $L_{eq}$  by  $10 \log 2$ , or approximately 3 dB.] Subjective tests have determined that the smallest change in noise level perceptible to the ear is approximately 3 dBA and that an increase of 10 dBA will cause the noise to sound about twice as loud to the average listener . . . If a traffic stream of 400 vehicles per hour (vph), for example, produces a noise level of 50 dBA at a certain distance from the observer, 800 vph traveling at the same speed and under identical conditions would produce 53 dBA, a change that is hardly noticeable. A further increase to 1,600 vph would produce 56 dBA and 4,000 vph about 60 dBA. Thus a ten-fold increase in traffic volume would result in an increase of 10 dBA and would sound about twice as loud to the average listener as 400 vph." (Ref. 2, p. 7)

Table 31-3 shows the relationship between a sound level change, the loudness, and the energy loss.

## H. Recommended Noise Limits

Table 31-4 gives recommended noise levels for various types of activities from a NCHRP study. Table 31-5 lists standards adopted for federal-aid highways; if a proposed design would produce a greater noise level, abatement procedures must be considered. The use of noise abatement procedures is intended to be designed to achieve a substantial noise reduction, not necessarily to meet noise abatement criteria.

There is flexibility for the State Highway Agencies (SHA) to establish a definition of "substantial increase" in noise levels. The FHWA will accept a well-reasoned definition that is uniformly and consistently applied. Several SHA definitions that have evolved are shown in Table 31-6.

**Table 31-3—Decibel Changes, Loudness, and Energy Loss**

Sound Level Change	Relative Loudness	Acoustic Energy Loss
0 dBA	Reference	0
-3 dBA	Barely perceptible change	50%
-5 dBA	Readily perceptible change	67%
-10 dBA	Half as loud	90%
-20 dBA	One quarter as loud	99%
-30 dBA	One eighth as loud	99.9%

Source: Ref. 3.

**Table 31-4—Recommended Design Criteria for Maximum Noise Levels**

Structure		Sound Pressure Level - dBA			
		Median		Exceeded 10% of the Time	
		Day	Night	Day	Night
Residences	Inside*	45	40	51	46
	Outside*	50	45	56	51
Schools	Inside*	40	40	46	46
	Outside*	55	—	61	—
Churches	Inside	35	35	41	41
Hospitals and Convalescent Homes	Inside	40	35	46	41
	Outside	50	45	56	51
Offices:					
Stenographic	Inside	50	50	56	56
Private	Inside	40	40	46	46
Theaters:					
Movies	Inside	40	40	46	46
Stage	Inside	50	45	56	51
Hotels, Motels	Inside	50	45	56	51

\* Either inside or outside design criteria can be used, depending on utility being evaluated.

Source: Ref. 13.

**Table 31-5—Noise Abatement Criteria for Federal-Aid Highways**

Activity Category	$L_{eq}(h)$ (hourly dBA)*	$L_{10}(h)$ (hourly dBA)*	Description of Activity Category
A	57 (Exterior)	60 (Exterior)	Land on which serenity and quiet are of extraordinary significance and serve an important public need and where the preservation of these qualities is essential if the area is to continue to serve its intended purpose.
B	67 (Exterior)	70 (Exterior)	Picnic areas, recreation areas, playgrounds, active sports areas, parks, residences, motels, hotels, schools, churches, libraries, and hospitals.
C	72 (Exterior)	75 (Exterior)	Developed lands, properties, or activities not included in Categories A or B above.
D	—	—	Undeveloped land.
E	52 (Interior)	55 (Interior)	Residences, motels, hotels, public meeting rooms, schools, churches, libraries, hospitals, auditoriums

NOTE: These sound levels are only to be used to determine impact. These are the absolute levels where abatement must be considered. Noise abatement should be designed to achieve a substantial noise reduction - not the noise criteria.

\*either  $L_{eq}(h)$  or  $L_{10}(h)$  but not both may be used on a project.

Source: Ref.14, Table 1.

**Table 31-6—Criteria Used by State Highway Agencies to Define "Substantial"**

	Increase (dB)	Subjective Descriptor
Criterion 1	0-5	Little increase
	5-15	Some increase
	>15	Substantial increase
Criterion 2	<10	Little increase
	>10	Substantial increase
Criterion 3	0-5	No increase
	5-10	Minor increase
	10-15	Moderate increase
	>15	Substantial increase

Source: Ref. 3.

## I. Noise Abatement Opportunities

1 **Vehicle Design.** Engine, muffler, tires, and latches can be designed to be quieter. Federal restrictions for commercial vehicle noise emissions have been implemented.

### 2 Traffic Operations:

- a. *Routing.* Through traffic should be routed away from noise sensitive areas. Commercial vehicle routes and prohibitions can be established. Noise should be considered in planning bus routes.
- b. *Speed.* Noise varies with speed (Eq. [31.4]; see also Ref. 1, Chap. 48, and Ref. 5). Reduced speed limits can reduce noise if enforced effectively.
- c. *Density of Traffic.* Each doubling of the density of traffic, both of autos and trucks, increases noise by about 3 dBA up to the point above which further rises in density reduce speed (see Chap. 4).
- d. *Smooth Flow.* Acceleration greatly increases noise peaks. Smooth flowing traffic, therefore, should be encouraged. Reducing the number of traffic control devices can reduce the noise produced by acceleration, but noise from higher speeds may result; therefore, an optimized balance should be the objective.
- e. *Reckless Operation.* Spinning of tires and high-speed turns are unsafe as well as noisy practices. If properly enforced, prohibiting these activities can reduce noise levels.

### 3 Road Design and Location.

- a. *Gradient.* Upgrades significantly increase noise from trucks, about 3 dBA for a 5% grade and 5 dBA for a grade of 7% or greater.
- b. *Elevation.* Placing the grade of the road either above or below the receptor (listener) level reduces noise; a depressed roadway can reduce sound levels 10-15 dBA for adjacent receptors.
- c. *Tunnels.* Will reduce noise outside the tunnel if the ends are baffled. Noise inside the tunnel, however, can be unpleasantly loud.
- d. *Road Location.* Facilities should be located away from noise-sensitive areas. Where possible, advantage should be taken of natural barriers, such as hills.
- e. *Noise Barriers.* Ref. 13, Chap. 3, is a useful guide for barrier design, landscaping, and walls. Noise barriers reduce sound by absorbing it, transmitting it, reflecting it, or forcing it to take a longer (diffracted) path. The maximum noise reduction achievable by a barrier (insertion loss) is 20-23 dBA. Walls have a noise reduction coefficient between 0 and 1, depending on the material; the higher the value, the more noise will be absorbed, and the lower the value, the more noise will be reflected. Typically, a 5 dBA noise reduction can be achieved by constructing a barrier that blocks the line of sight from the noise source to the receptor. Each additional meter of wall height will produce an additional 1.5 dBA reduction, but at additional cost. A berm will typically provide 1-3 dBA noise reduction.

The relative feasibility of attaining a sound level reduction through barrier construction is given in Table 31-7. The effectiveness of barriers can be enhanced by minimizing breaks (e.g., driveway openings) in the wall, and by increasing the distance from the source to the receptor; sound levels drop as a function of the distance from source to receptor - note the "distance adjustment" term in Eq. [31.5].

**Table 31-7—Barrier Insertion Loss vs. Design Feasibility**

Barrier Insertion Loss	Design Feasibility	Reduction in Sound Energy	Relative Reduction in Loudness
5 dBA	Simple	68%	Readily perceptible
10 dBA	Attainable	80%	Half as loud
15 dBA	Very difficult	97%	One-third as loud
20 dBA	Nearly impossible	99%	One-fourth as loud

Source: Ref. 14, Table 9.

Disadvantages of barriers include possible conflicts with sight distance requirements, vehicle impact hazard, and a place of concealment, graffiti, and litter accumulation.

Ref. 15 gives standards for noise barrier dimensions and locations for California state highways. General AASHTO standards are presented in Ref. 16. Ref. 17 contains noise barrier design information. Refs. 18 and 19 present case studies in Milwaukee, WI, and Nashville, TN, respectively.

- f. *Natural and Man-Made Structures* (Ref. 13, Chap. 3.3.4 ). The perception of traffic noise impact tends to decrease when vegetation blocks the line of sight from the source. However, for vegetation to provide a noticeable noise reduction - up to 5 dBA — it must be at least 5 m high and 30 m deep. Taller and deeper areas can increase this reduction to about 10 dBA. The amount that man-made structures, such as rows of buildings, can reduce noise levels depends on the ratio of building area to gap area: a 40-60% building-to-gap ratio can provide a 3 dBA reduction with 0.5 dBA more for each row of buildings added.
- g. *Ground Effects* (Ref. 13, Chap. 3.3.4) refers to the change in sound level due to the type of intervening ground between source and receptor. "Hard" ground (paving, water, etc.) is highly reflective and reduces noise levels only negligibly; "soft" ground (shrubbery, fields) absorbs somewhat more.
- h. *Pavement Design*. Flexible pavements, such as asphalt rubber, and open-graded, porous pavements have been shown to provide noise reduction benefits. Data have shown that automobile noise levels were 3-5 dBA higher on concrete pavements than on dense-graded asphalt which, in turn, are about 1.5 dBA higher than those produced on open-graded asphalt. (See Fig. 31-2).

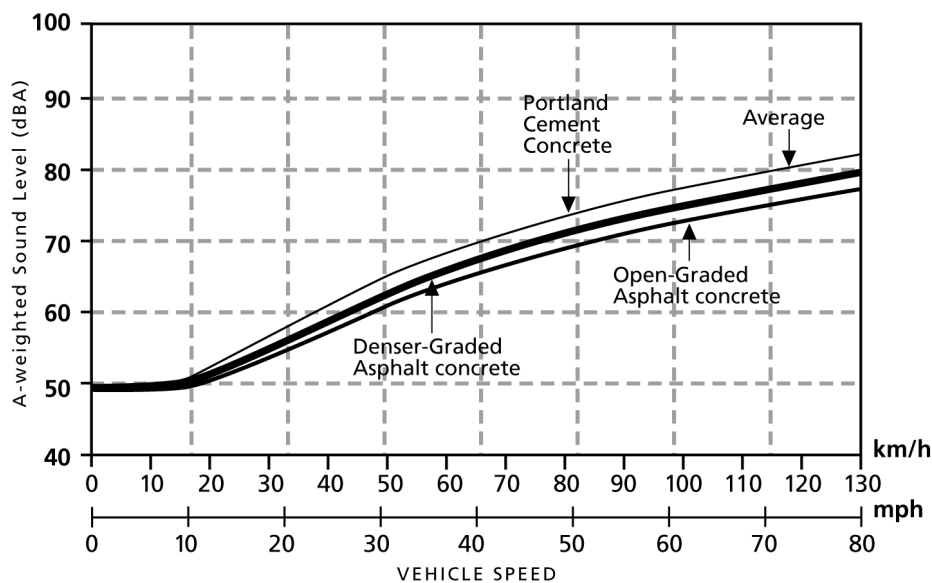

Source: Ref. 4.

**Fig. 31-2—A-Weighted Noise Emissions by Type of Pavement  
Automobiles, Cruise Throttle**

**4 Land Use Planning.** (See Ref. 1, p. 49.4-49.8; Ref. 2; Ref. 3, p. 32-54; Ref. 20.)

- a. *Distance from Roadway*. Traffic noise decreases by about 4.5 dBA for each doubling of the distance between source and listener at absorptive sites and 3 dBA at reflective sites.
- b. *Street Width*. Narrow streets fronted by buildings can channelize and amplify noise. A distance greater than 12 m between building fronts should be maintained.

- c. *Building Orientation and Layout.* Noise-compatible buffers—e.g., long buildings used by industry or warehousing, fully soundproofed buildings—can be placed between noise sources and sensitive receivers. Interior noise can be minimized by orienting buildings with the most open sides (i.e., windows and doors) facing away from the noise source, and arranging the interior layout with the most sensitive parts (living and bedrooms) farthest from the noise source.
  - d. *Building Insulation.* Windows are the weakest links in sound proofing. The interior noise level from exterior sources is from 5 to 10 dBA less than outdoors when windows are open, from 15 to 20 dBA less with closed simple windows, and from 25 to 30 dBA less with closed double windows. Window panes should fit tightly into frames, and the frames tightly into the building. Panes of double windows should be of different thicknesses.
- 5 **Noise Ordinances.** Maximum allowable noise emissions can be limited by state legislation generally and by local ordinances for specific locations or by time of day. The statewide limit in California for motor vehicle noise emission is 80 dBA measured at 15 m from the vehicle for all passenger cars manufactured after 1974, for various categories of trucks manufactured after 1977-1987, and for motorcycles manufactured after 1985. This means that most motor vehicles in operation are now covered by the 80 dBA limit. (Ref. 21, §27202, 27204, 27206)

#### REFERENCES

1. Harris, C.M. (Editor). *Handbook of Acoustical Measurements and Noise Control*. 3rd Ed. New York: McGraw-Hill, 1991.
2. American Association of State Highway and Transportation Officials. *Guide on Evaluation and Abatement of Traffic Noise 1993*. Washington DC: 1993, 40 p.
3. U.S. Department of Transportation. *Highway Traffic Noise Analysis and Abatement Policy and Guidance*. FHWA Office of Environment and Planning, Washington, DC. June 1995.
4. Menge, C. et al. *FHWA Traffic Noise Model, Version 1.0, Technical Manual*. Washington, D.C.: FHWA, Report DOT-VNTSC-98-2. 1998.
5. Barry, T.M. and J.A. Reagan. *FHWA Highway Traffic Noise Prediction Model*. Washington, DC: FHWA, Report FHWA-RD-77-108, Dec. 1978.
6. Knauer, H., et al. *FHWA Highway Noise Barrier Design Handbook*. Washington, DC: FHWA, Report DOT-VNTSC-FHWA-00-01. 2000.
7. Anderson, G. et al, *FHWA Traffic Noise Model, Version 1.0, User's Manual*. Washington, DC: FHWA, Report DOT-VNTSC-98-1. 1998.
8. Lee, C.S.Y. and G.G. Fleming. *Measurement of Highway Related Noise*. Cambridge, MA: Report No. FHWA-PD-86-046. Volpe Transportation Systems Center, Acoustical Facility. Oct. 1996.
9. Wayson, R.L., T.W.A. Ogle, and W. Lindeman. "Development of Reference Energy Mean Emission Levels for Highway Traffic Noise in Florida." *Transportation Research Record 1416*. 1993. pp. 82-91.
10. Kugler, B.A., D.E. Commins and W.J. Galloway. "Highway Noise: A Design Guide for Prediction and Control." *NCHRP Report 174*. Washington DC: Transportation Research Board, 1976, 193 pp.
11. Nelson, D.C. "Environmental Impacts of Transportation Projects." In: *Manual of Transportation Engineering Studies*. Englewood Cliffs, NJ: Prentice-Hall, 1994, Chapter 8.
12. Bowlby, W. *Sound Procedures for Measuring Highway Noise: Final Report*. Washington, DC: FHWA, Report FHWA-DP-45-1R, 1981.
13. Gordon, C.C., et al. "Highway Noise: A Design Guide for Highway Engineers." *NCHRP Report 117*. Washington, DC: Highway Research Board, 1971.
14. United States. *Code of Federal Regulation*, Title 23 Part 772. As of April 1, 2005.

15. California Dept. of Transportation. *Highway Design Manual, 5th Ed.*. Sacramento, CA: 1995, Part 1100, updated Nov. 2001.
16. American Association of State Highway and Transportation Officials. *A Policy on Geometric Design of Highways and Streets*. Washington DC: 2004, pp. 344-347.
17. Farnham, J. and E. Beimborn. *Noise Barrier Design Guidelines*. Washington, DC: U.S. Dept. of Transportation, Technology Sharing Program, Report DOT-T-90-15, July 1990, 126p.
18. Farnham, J. and E. Beimborn. "Techniques for Aesthetic Design of Freeway Noise Barriers." *Transportation Research Record 1312*. 1991, pp. 119-129.
19. Herman, L., et al. "Determination of Traffic Noise Barrier Effectiveness: An Evaluation of Noise Abatement Measures Used on I-440." *Transportation Research Record 1416*. 1993, pp. 75-81.
20. Urban Systems Research and Engineering Co. *The Audible Landscape: A Manual for Highway Noise and Land Use*. Washington, DC: U.S. FHWA. (US GPO Stock No. 5000-00079), 1974.
21. California. *Vehicle Code*. Sacramento, CA: Annual. <http://www.dmv.ca.gov/pubs/vctop/vc/vc.htm>.

**A. General**

Despite periodic spikes in fuel prices, occasional blackouts, fuel shortages, and years of dire predictions, vehicle-kilometers of motor vehicle travel continue to increase worldwide at dramatic rates in some developing countries, and prosperity invariably seems to be accompanied by shrinking or at best stagnant shares of travel by public transportation and alternative modes. In 2002, with less than 5% of the world's population, the U.S. accounted for just over 10% of the world's petroleum production and 25% of its consumption (Ref. 1, Tables 1.3 and 1.4). As shown in Chap. 2, the automobile still represents the lion's share of U.S. passenger travel, and trucks carry a substantial part of the freight. Similarly, European statistics show short-term stagnation and long-term shrinkage in the use of collective modes of transportation. (Ref. 2)

Transportation systems consume more than a quarter of all energy used in the U.S., with the share increasing slowly through the past quarter century (Table 32-1). Petroleum, more than half of which is imported (see Ref.1, Table 1.8), provides almost all the transportation energy used in the U.S. (Table 32-2). Statistics show a continued increase in demand for transportation energy, which grew at an annual rate of 1.7% between 1992 and 2002 (Ref.1, Table 2.1). Traffic engineers need to be cognizant of trends in energy consumption for transportation systems and the key issues that can influence energy consumption and availability for highway transportation in the future.

**Table 32-1—U.S. Energy Consumption by End-Use Sector, 1975 Through 2002**

End-Use Sector	Percent of Total Energy Consumed			
	1975	1985	1995	2002
Transportation	25.3%	26.3%	26.3%	27.2%
Residential/Commercial	33.8%	35.8%	36.6%	39.1%
Industrial	40.9%	37.9%	37.1%	33.7%

Source: Ref. 1, Table 2.1.

**Table 32-2—Energy Consumption in Transportation by Source, 1973 and 2002**

Type of Fuel	Percent of Total Fuel Consumed	
	1973	2002
Petroleum	95.8	96.8
Natural Gas (pipelines, vehicles)	4.0	2.3
Electricity, (incl. elec. system losses)	0.2	0.2
Renewable Sources (including alcohol fuels)	0.0	0.7

Source: Ref. 1, Table 2.2



- 1 **History.** Prior to the 1970s, energy for transportation was largely taken for granted by the typical American. However, OPEC oil embargoes against the U.S. in 1973 and 1979 revealed the nation's vulnerability to the international energy supply system, and the Congress responded with several mandates:
- The Emergency Petroleum Allocation Act of 1973 instituted a government allocation plan and price controls for petroleum, which remained in effect into the 1980s. Administrative and legal actions stemming from associated price control violations continued well past the year 2000.
  - The Emergency Highway Energy Conservation Act of 1974 established a national speed limit of 88 kph. [55 mph] and carpool demonstration programs. The national 88 kph speed limit was later repealed by the National Highway System Designation Act of 1995 (PL 104-59).
  - The Energy Policy and Conservation Act of 1975 (PL 94-163) created the Strategic Petroleum Reserve (SPR) in order to dampen temporary disruptions in supply, and created the Corporate Average Fuel Economy (CAFE) standards setting minimum average fuel economy targets for new light passenger vehicles sold (see C.3. below).
- 2 **Consumption by Mode** (Table 32-3). Of the nearly 28% of total energy consumed in transportation, highway vehicles account for nearly 85% (70% for passenger travel, 15% for freight movements). Aircraft consume about 10% and rail and water vehicles (including urban rail transit) together consume about 5%. As noted, almost all this energy is obtained from petroleum. The table does not cover non-vehicular transportation, pipelines in particular, that use about the same amount of energy as rail and water combined, and where natural gas plays a significant role.

**Table 32-3—Direct Energy Use and Intensity by Vehicle Type, U.S., 2001**

Type of Vehicle	Total Energy Use		Energy Intensity
	Trillion kJ	Percent	
<b>Passenger Transportation</b>			<b>(kJ/psgr·km)</b>
Automobiles	9,625	39.4%	2,352
Light trucks	7,020	28.8%	
Motorcycles	25.1	0.1%	
Buses – Transit	96.6	0.4%	2,704
Intercity	34.1	0.1%	611
School	83.6	0.3%	
Aircraft - Commercial	2,369	9.7%	2,601
General Aviation	174.2	0.7%	6,807
Recreational boats	330.7	1.4%	
Rail – Intercity (Amtrak)	24.3	0.1%	2,712
Urban Transit	51.3	0.2%	2,041
Commuter	27.3	0.1%	1,781
<b>Freight Transportation</b>			<b>(kJ/t·km)</b>
Trucks	3,700	15.2%	2,188
Waterborne Commerce	291.2	1.2%	291
Class I Railroads	545.4	2.2%	227
<b>Total – Passenger and Freight</b>	<b>24399</b>	<b>100%</b>	

Source: Calculated from Ref. 1, Tables 2.5, 2.12, 2.13 and 2.14.

- 3 **Environmental Impacts.** Long-term and recent trends show increasing dependence on petroleum, availability of which is vulnerable to worldwide political instability and eventually physical depletion. However, studies show that, depending on the assumptions made, fossil fuel depletion remains decades, perhaps centuries, away (Ref. 2.) It appears most Americans consider air pollution to be a more serious external consequence of travel than energy use per se. However, for given fleet characteristics, the two go together, since tailpipe emissions are the direct consequence of burning fuel. Although emissions are influenced by many factors,

carbon monoxide (CO) and nitrogen oxide (NO<sub>x</sub>) emission rates generally exhibit the same flattened U-shaped relationship to speed as fuel consumption, with the highest values occurring at the low and high ends of the speed range. Continued high rates of petroleum consumption will continue to produce substantial air pollution and greenhouse gas emissions, despite the long-term improvements in emissions technologies and in vehicle fleet fuel efficiency that have been achieved during recent decades.

## B. Modal Comparisons of Energy Efficiency

It is difficult to compare energy efficiency across different transportation modes:

Construction of transportation links, vehicle fleets, and major terminals, including the mining and manufacture of the requisite materials, often consumes more energy than is used for many years after the transportation facility enters operation. It can be argued that comparisons of only the direct energy used in operations are incomplete and potentially misleading.

There are problems in selecting appropriate system output units as a base for modal comparisons, and accounting for energy losses in refining, generating, and transportation/transmission of fuels and power.

The structure and operating constraints of transportation systems inherently impose certain energy inefficiencies. Some networks are inherently more circuitous than others (e.g., railroad distances between cities are greater than airline distances). Unproductive vehicle movements, such as deadheading empty oil tankers, trucks, and buses, consume energy without adding to output. Infrequent access points, e.g., in air transportation, require energy for access travel that is not reflected in most modal comparison figures.

Therefore, generalizations are fraught with danger. Nevertheless, a general indication of the relative operating energy efficiencies of the different transportation modes appears in the last column of Table 32-3. These values are replete with assumptions about operating procedures, load factors, speeds, and trip lengths. Perhaps surprisingly, autos, bus transit, airlines, and Amtrak all show roughly 2500 kJ of operating energy per passenger-kilometer of transportation provided in 2001, which corresponds to about 14 psgr-km per liter [33 psgr-miles per gallon].

## C. Fuel Consumption by Highway Vehicles

In view of the large amounts of fuel used by highway vehicles, improving the energy efficiency of these vehicles is identified as a public policy goal. The following provides a discussion of major physical factors affecting fuel consumption for automobiles and light trucks, as well as some policy aspects. These comments are also relevant for analyzing truck and bus operations and, more generally, rail operations. Refs. 3 and 4 contain useful insights on this subject.

### 1 Vehicle Design Factors.

- a. *Mass.* The forces required to overcome inertia when accelerating and to climb grades are proportional to the mass of the vehicle (curb weight plus load). Automobile curb weights dropped substantially after the fuel shortages of the 1970s, with the average new car curb weight falling from 1636 kg in 1975 to 1266 kg in 1980, after which it rose gradually to 1390 kg in 2002. (Ref.1, Tables 4.9 and 4.12) However, starting in the mid-1980s, American consumer preference shifted away from automobiles toward larger vehicle types, initially toward small vans and by the mid-1990s toward SUVs. As illustrated in Figure 32-1, in 1980 automobiles and pickups amounted to about 80% and 15%, respectively, of the new light vehicle market. By 1992, autos amounted to just under 50% of sales and pickups 18%, due to a 3% increase in the market share of large pickups. By 1992, utility vehicles amounted to about 25% of the new light vehicle market, with medium-size utilities, in the 1590-2180 kg range, dominating the mix. The fuel economy implications of this dramatic change are discussed in C.3. below.

b. *Engine* (see also Chap. 30, Sec. J.3 and J.4). While substantial fuel savings have been obtained by improving the efficiency of the conventional (Otto cycle) internal combustion engine, even greater promise may lie in the development of new engine types. For example, the stratified-charge engine (a cross between an Otto gasoline engine and a diesel) improves fuel economy by 30%.

(1) *Electric* vehicles with performance capabilities comparable to standard automobiles and vans still await the development of economical low-weight, high-capacity batteries. Many view vehicle electrification as the most feasible long-term path to sustainability. (Ref. 5) In 1998 the National Transportation Safety Administration (NHTSA) designated the "low-speed vehicle" as a new class of roadworthy vehicles. LSVs differ from golf carts by having standard road safety equipment like turn signals, mirrors, wipers, lights, and seatbelts. Through 2004, DaimlerChrysler, has produced about 30,000 LSVs at its Global Electric MotorCars (GEM) plant in Fargo, North Dakota, and markets them internationally (Refs. 6 and 7). The GEM has 2-passenger and 4-passenger models, operates up to 40 km/hr with about a 50 km range, and requires 11-12 hours to recharge.

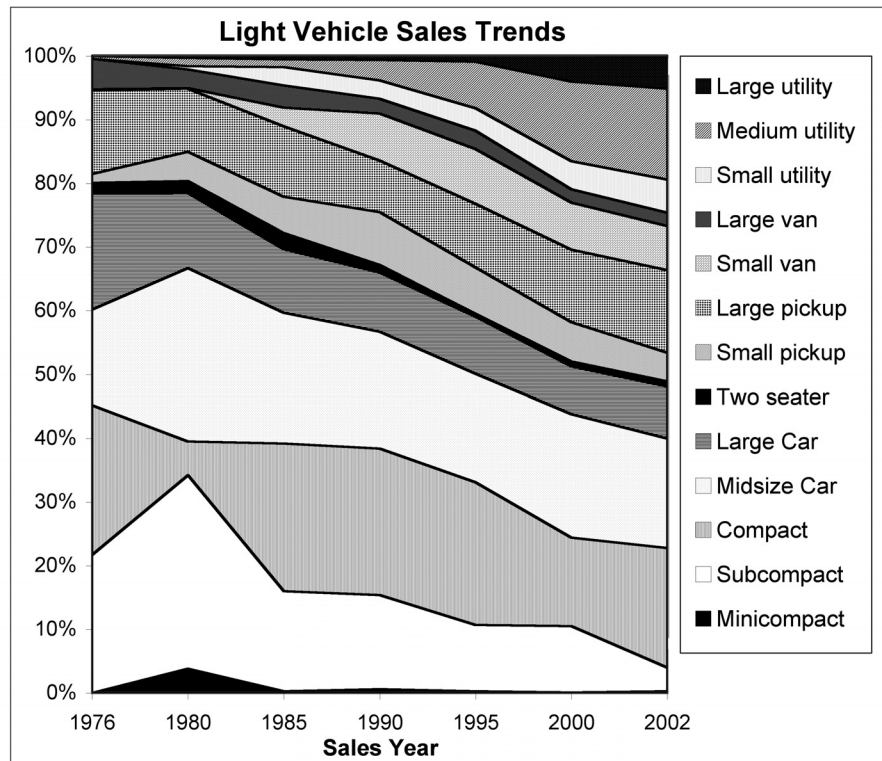

Source: Ref. 1. Table

Note: Average curb weights for new cars sold in 2002, and light truck weight ranges are shown below:

Car Types	Average Wt. (kg)	Truck Types	Wt. Range (kg)
Minicompact	1,392	Small pickup	< 1590
Subcompact	1,328	Small van	< 2040
Compact	1,239	Small utility	< 1590
Midsize	1,460	Large pickup	1590 – 3860
Large	1,627	Large van	2040 – 3860
Two seater	1,400	Medium utility	1590 – 2180
All-car average	1,391	Large utility	2180 – 3860

Source: Ref. 1, Table 4.12

Fig. 32-1-Trend in Market Shares for New Sales of Light Vehicles, U.S.

- (2) *Hybrid cars*, which use gasoline engines to supplement and recharge battery power, have shown dramatic market success in recent years. Such vehicles use about 25% and 10% less energy under urban and highway conditions, respectively, which has generated some recent criticism about whether the energy benefits justify the added cost for this sophisticated technology (Ref. 8). Nevertheless, there are currently seven hybrid models (three cars, four pickups) available from Toyota, Honda, GMC and Chevrolet, and some industry pundits predict that 50 hybrid models will be on the market by 2010 (Ref. 9). During the first part of 2004, U.S. sales of the popular Toyota Prius were about 4,000/month, while two Honda hybrid models, the Civic and Insight, sold about 2,200/month, the latter equal to about 8.5% of all Honda Civic sales for the period. (Refs. 10, 11)

General Motors has produced hybrid (diesel-electric) buses at \$600,000 to \$800,000 extra cost per vehicle. Fleets of these buses were operating in New York City, Philadelphia, and Seattle as of late 2004. However, fuel consumption results were disappointing – only about 10% to 20% lower than standard diesels instead of the 60% claimed by GM (Ref. 12).

- (3) *Fuel cell vehicles* (FCV) have also received a good deal of recent attention (Refs. 12, 14). This technology creates electricity from hydrogen through chemical reaction. DaimlerChrysler, Ford, General Motors, Honda, Hyundai, Nissan, Toyota, and Volkswagen have all developed prototype fuel cell vehicles. As of 2005, the California Fuel Cell Partnership had more than 55 fuel cell cars and SUVs, along with eleven fueling stations participating in a light vehicle demonstration program. In addition, three California transit operators (Coachella Valley's SunLine Transit, Santa Clara Valley Transportation Authority, and AC Transit) are now demonstrating fuel cell buses. Despite long-term promise and strong political support, widespread implementation of fuel cells will probably require at least 10 years to bring unit cost to reasonable levels and, even more problematic, deploy a suitable fuel-distribution system.
- c. *Shape and Frontal Area*. These factors determine the amount of aerodynamic drag, discussed further in paragraph C.2.a.
- d. *Rolling Resistance*. Rolling resistance is related to vehicle mass, tire characteristics, and drive train bearings. It is relatively independent of speed. Radial tires minimize rolling resistance at the contact with the pavement surface sufficiently to improve fuel economy perhaps 3% compared to conventional tires. Pavement texture also affects rolling resistance.
- e. *Transmission Type and Axle Ratio*. Automatic transmissions are typically less fuel efficient than manual transmissions at low speeds and when climbing grades because of torque converter slip. At high speeds, the ability to use a leaner fuel mix and lower axle ratio make the automatic transmission superior. The axle ratio determines the power performance of a vehicle: the lower the ratio, the lower the acceleration rate possible. Fuel use drops with decreasing axle ratios to a minimum at a ratio about 2.25, but increases for even lower ratios. The use of front-wheel drive generally reduces both vehicle curb weight and energy losses in the drive shaft and differential.
- f. *Accessories*. Power-operated accessories consume fuel and reduce efficiency.
- (1) Air conditioning power needs vary directly with ambient temperature and inversely with speed; e.g., at an ambient temperature of 30°C, an air conditioner may decrease fuel efficiency by 0.85 km/L at 65 km/h, but by only half that amount at 100 km/h.
- (2) The reduction of fuel efficiency caused by power steering also varies inversely with speed, being about 0.25 km/L at 50 km/h and 0.17 km/L at 105 km/h.

## 2 Vehicle Operating Factors.

- a. *Speed*. Aerodynamic drag is negligible at low speeds, but becomes the major resisting force at speeds above 80 km/h. At low speeds other factors (especially the high axle ratio required) detract from fuel economy. A plot of a typical vehicle's overall fuel consumption (L/100 km) as a function of speed reaches a minimum in the region of 65 km/h. The increase in fuel consumption above that speed for passenger cars can be seen in the data in Table 32-4.

b. *Change in Speed.* Acceleration requires more power than cruising. Deceleration wastes kinetic energy through the engine and brakes (except in hybrids, where it is routed to recharge the propulsion batteries). The additional fuel consumption from speed changes can be obtained approximately from Fig. 32-2 (Ref. 16). At idle, the fuel consumed does not produce any useful transportation service. Fuel economy can therefore be enhanced by traffic engineering measures that minimize unnecessary speed changes.

**Table 32-4—Passenger Car Fuel Consumption at Various Speeds**

Curb Weight (kg)	Fuel Consumption (L/100 km) at speed of:					
	72 km/h	80 km/h	89 km/h	97 km/h	105 km/h	113 km/h
905	5.9	6.3	6.7	7.1	7.7	8.2
1135	6.8	7.2	7.7	8.3	8.9	9.7
1360	8.7	9.0	9.6	10.1	10.8	11.6
1590	10.1	10.4	10.7	11.3	12.1	13.4
1815	10.9	11.4	11.9	12.5	13.3	14.2
2040	11.8	12.2	12.6	13.3	13.9	15.0
2270	12.7	13.1	13.7	14.3	14.9	15.6

Source: Adapted from Ref. 15, Table 2-1.

c. *Cold Engine.* Fuel consumption is considerably higher during the warm-up period than after the engine has reached normal operating temperature.

When the factors discussed above are considered together, an average fuel economy figure for various driving conditions can be calculated. A number of different driving cycles have been developed to represent typical driving conditions; some are used in bench tests of vehicles, others on test roads. Some simulate urban traffic conditions, some suburban and rural. Such driving cycles are also used in emission measurement (see Chap. 30, Sec. J).

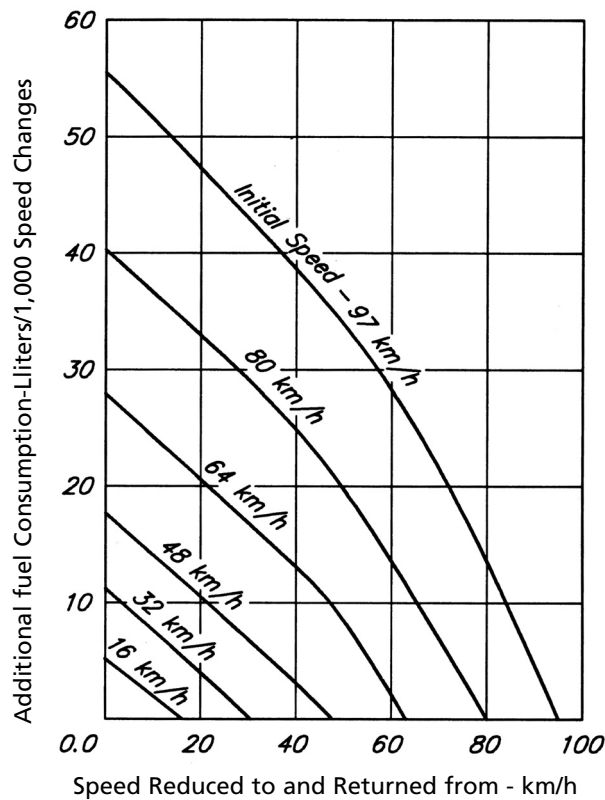

Source: Ref. 16.

**Fig. 322—Additional Fuel Consumption of Vehicular Speed Changes Above Consumption of Continuing at Uniform Speed (For light-duty vehicles)**

**3 Overall Fuel Economy.** Federal regulations require manufacturers to produce motor vehicles that meet Corporate Average Fuel Economy (CAFE) standards. Currently, a manufacturer's auto fleet must average 11.7 km/L (27.5 mpg) and the light truck fleet 8.8 km/L (20.7 mpg). Utility vehicles are considered part of the light truck fleet. Although there have been repeated efforts in Congress to adopt higher future CAFE targets, such as 15.3 km/L (36 mpg), and to make the target for light trucks equal to that of autos, as yet the original standards set by the 1975 legislation remain in effect. One exception is that, in April 2003, NHTSA issued a rule requiring light trucks to achieve 9.4 km/L (22.2 mpg) by 2007. In addition, NHTSA has embarked on a congressionally-mandated study to review all the CAFE standards for possible future changes. (Ref. 17)

Failure to achieve CAFE standards results in levying fines on each vehicle sold that, presumably, would be added to the vehicle purchase price. Before such regulations (in 1974), the average passenger car fuel efficiency for all manufacturers' new models was 6.0 km/L (about 14 mpg). The national goal of 11.7 km/L was first achieved for all new cars sold, including imports, in 1985 and for all new cars produced domestically in 1993. By 2001 the average fuel economy of domestically produced cars slightly surpassed imports, and averaged 12.16 km/L (28.6 mpg) for all new cars sold. Light trucks first achieved the target of 8.8 km/L in 1983 for all vehicles, including imports, and for domestically produced vehicles in 1991. In 2001 the average fuel economy of all light trucks sold averaged 8.9 km/L (20.9 mpg), just slightly above the national standard (Ref. 17, Table 2).

Despite fuel economy improvements, total U.S. highway energy consumption increased at an annual rate of 2.4% between 1991 and 2001 (Ref. 1, Table 2.6), twice the rate of the preceding decade, because:

- as seen in Fig. 32-1, many Americans have moved from more fuel efficient passenger cars to less efficient light trucks—pickups, vans, and sports utility vehicles, and
- vehicle-kms. of travel continually increase, growing 2.5% per year from 1991–2001. (Ref. 1, Table 2.6)

**4 Signal Operation and Fuel Economy.** Research has examined fuel consumption at urban intersections under various types of controls. In most areas about half of the signalized intersections are spaced closely enough to be operated as coordinated systems. Optimization of signal timing has been found to reduce fuel consumption by 6–10%. For example, the Fuel Efficient Traffic Signal Management (FETSIM) Program between 1983 and 1993 simulated signal optimization for 163 coordinated signal systems throughout California and found that retiming these signals could produce an average 7.8% reduction in fuel use (Ref. 19).

Because of increased delays, more fuel is expected to be burned at signal-controlled intersections than at two-way stops (Ref. 4). Hence, if signals are installed where not warranted as described in Chap. 19, energy waste may result.

Fig. 32-3 results from an investigation of differences in fuel consumption with different types of signal control strategies. The low level of fuel use when yellow/red flashing is in operation is noteworthy. On the other hand, under certain circumstances, accidents could increase when flashing operation is used. The "Flashing Red/Red" case in the figure may also be interpreted to represent a fourway STOP sign installation.

Traffic signal operation also consumes electricity, both for illumination of the lamps and for operation of the controllers and auxiliary equipment. However, energy use for illumination is being dramatically reduced by conversion to light-emitting diode (LED) technology, now available in all colors and shapes needed for traffic signal systems. A LED traffic signal lamp consumes 80–90% less electricity and generally lasts 5–7 years, compared to one year for a typical incandescent lamp. Although the initial cost of LED lamps may be 4–5 times that of incandescent lamps, the life-cycle cost is less than half (Ref. 20). In addition, LEDs' low power consumption permits inexpensive stand-by batteries to keep signals operating during lengthy power outages. The ITE has adopted purchase standards for a number of LED lamp types (Ref. 21). See Chap. 15, Part B.1. for more information on new signal lamp requirements.

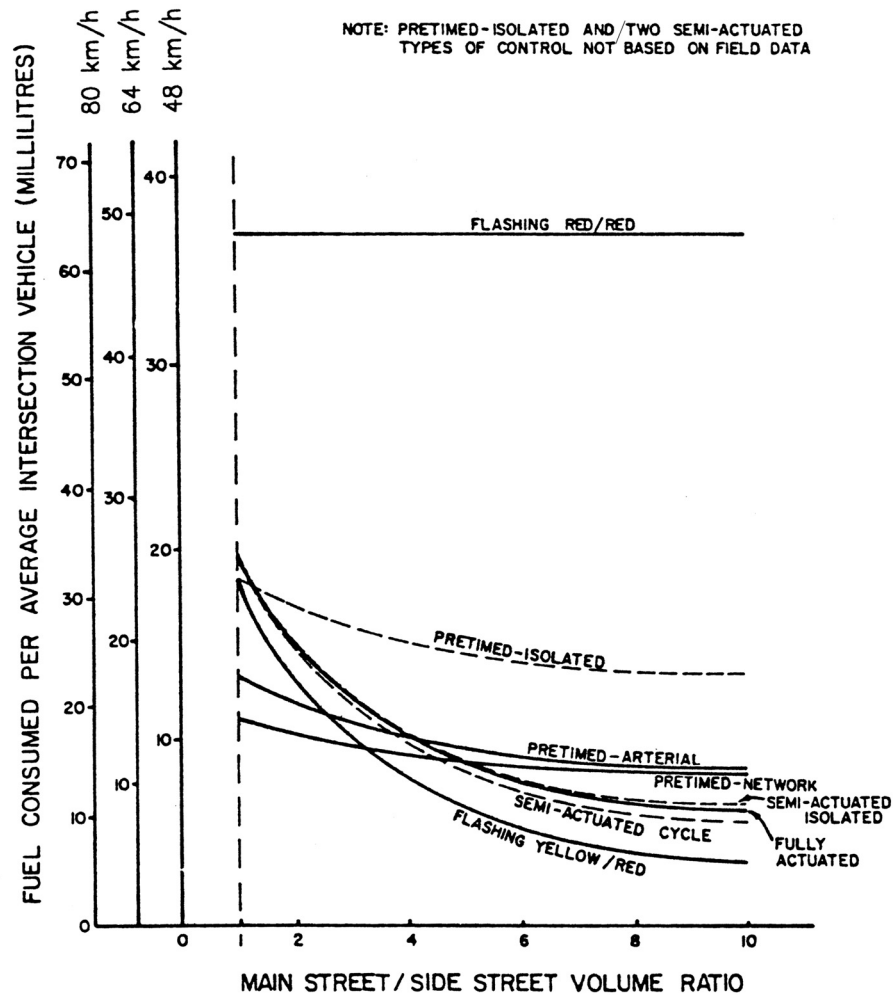

Source: Ref. 18.

**Fig. 32-3—Average Fuel Consumption for Different Speeds and Modes of Signal Operation**

#### REFERENCES

1. Davis, S. C. and S. W. Diegel. *Transportation Energy Data Book 23*. Oak Ridge, TN: Oak Ridge National Laboratory, Report ORNL-6970. 2003. On-line. Internet. November 2004. Available: <http://www-cta.ornl.gov/data/>.
2. Greene, D. L. and J. M. Decicco. *Energy And Transportation Beyond 2000. Transportation In The New Millennium*. Washington DC: Transportation Research Board, National Academy Of Sciences. 2004, 10 p. On-Line. Internet. Nov. 2004. Available: <http://Gulliver.Trb.Org/Publications/Millennium/00032.Pdf>.
3. Society of Automotive Engineers. *Automotive Fuel Economy*. Warrendale, PA: Progress in Technology Series, v. 15, 1976.
4. Greene, D.L. and Y. Fan. "Transportation Energy Intensity Trends: 1972-1992." *Transportation Research Record 1475*. Washington DC: Transportation Research Board. 1995, pp. 1019.
5. Sperling, D. *Future Drive: Electric Vehicles and Sustainable Transportation*. Washington DC: Island Press, 1995, 175 pp.
6. Squatriglia, C. "Cartoon-Like 'Egg' Cruisers Tackle S.F. Streets". *San Francisco Chronicle*, Aug. 7, 2000.
7. GEMcar Website. On-line. Internet. Dec. 2004. Available: <http://www.gemcar.com/>.

8. Truitt, Richard. "Comment: Civic Hybrid and Prius Are Overrated." *Automotive News*. May 10, 2004.
9. Truitt, Richard. "50 Hybrid Models Predicted by 2010." *Automotive News*. Dec. 6, 2004.
10. Link, Monica. "Toyota to Boost Prius Shipments to 100,000 in '05". *Automotive News*. Sept. 30, 2004.
11. "Honda Accord Hybrid to Nearly Double Sales in '05". *Automotive News*. Dec. 10, 2004.
12. WALD, Matthew L. "'Magic' Fuel-Saving Buses Fall a Bit Short on Wonders." *The New York Times*. Dec. 26, 2004, p. 23.
13. Hoffmann, P., and R. Rose. *Toward Tomorrow's Energy: Speeding the Commercial Use of Fuel Cells and Hydrogen*. Washington, DC: Progressive Policy Institute, Policy Report, January 22, 2003. On-line. Internet. December 2004. Available: [http://www.ppionline.org/ppi\\_sub.cfm?knlgAreaID=116&subsecID=155](http://www.ppionline.org/ppi_sub.cfm?knlgAreaID=116&subsecID=155).
14. Sperling, D. *FreedomCAR and Fuel Cells: Toward the Hydrogen Economy?* Washington, DC: Progressive Policy Institute, Policy Report, January 22, 2003. On-line. Internet.. December 2004. Available: [http://www.ppionline.org/ppi\\_sub.cfm?knlgAreaID=116&subsecID=155](http://www.ppionline.org/ppi_sub.cfm?knlgAreaID=116&subsecID=155).
15. Mason, R.L. and R.W. Zub. *Highway Fuel Economy Study*. Washington, DC: US DOT, National Highway Traffic Safety Administration, Report DOT-TSC-NHTSA-81-18, June 1981, v.p.
16. Dale, Charles W. *Procedure for Estimating Highway User Costs, Fuel Consumption, and Air Pollution*. Washington, DC: U.S. FHWA, March 1980. Appendix A.
17. Bamberger, R. *Automobile and Light Truck Fuel Economy: The CAFE Standards*. Washington DC: Congressional Research Service, Library of Congress. Issue Brief IB90122, Nov. 8, 2004. Online. Internet. Dec. 2004. Available: <http://www.ncseonline.org/NLE/CRS/abstract.cfm?NLEid=17010>.
18. Kacir, K.C. et al. "Analysis of Flashing Signal Operation." *Transportation Research Record 1421*. Washington DC: Transportation Research Board, 1993. p. 21-29.
19. Skabardonis, A. ITS Benefits: The Case of Traffic Signal Control Systems. Washington DC: Proceedings of the 80th Annual Meeting, Transportation Research Board, paper #01-3286, January 2001. On-line summary. Internet. December 2004. Available: <http://www.benefit-cost.its.dot.gov/its/benecost.nsf/>.
20. Consortium for Energy Efficiency (CEE). LED Traffic Signals. Boston MA: brochure, 2 pp. On-line. Internet. December 2004. Available: <http://www.cee1.org/gov/led/led-main.php3>
21. Institute of Transportation Engineers. "Standards – LED Traffic Signals". Washington DC. Various dates, 1997-2004: On-line. Internet. Dec. 2004. Available: <http://www.ite.org/standards/led.asp>.





### A. Purpose of Traffic Legislation

"The proper purpose of all traffic legislation is not to impose unnecessary or unreasonable restrictions on highway traffic, but to insure, as far as this can be done by law and its application, that traffic shall move smoothly, expeditiously and safely; that no legitimate user of the highway, whether in a vehicle or on foot, shall be killed, injured or frustrated in such use by the improper behavior of others." (Ref. 1, p. vi).

### B. Definitions

- 1 **Laws.** Acts passed by the U.S. Congress and state legislative bodies; include motor vehicle codes of states and legislation delegating certain powers to local governments.
- 2 **Ordinances.** Acts passed by legislative bodies of local governments under authority given by state constitutions or by enabling acts.

### C. Federal Legislation

Traffic legislation had traditionally been a state function. However, especially since the 1960s, the U.S. Congress has enacted several major laws.

- 1 **The Interstate Commerce Act of 1935.** This act included provisions for establishing safety regulations for interstate trucks and buses. In 1967 the administrative responsibilities were assigned to the Bureau of Motor Vehicle Safety within the Federal Highway Administration. The current regulations (Ref. 2) cover the following subjects:
  - a. Qualifications of drivers.
  - b. Driving of commercial motor vehicles.
  - c. Parts and accessories necessary for safe operation.
  - d. Hours of service of drivers.
  - e. Inspection, repair, and maintenance.
  - f. Driving and parking rules when transporting hazardous materials.
  - g. Transportation of migrant workers.
  - h. Employee safety and health standards.
- 2 **The National Traffic and Motor Vehicle Safety Act of 1966** (Ref. 3) **and the Highway Safety Act of 1966** (Ref. 4) created the predecessor agency to the National Highway Traffic Safety Administration (NHTSA) within the Department of Transportation. It was instructed to promulgate motor vehicle and tire safety standards (para. H.3. below and Ref. 5). Ref. 3 also established an Accident and Injury Research and Test Facility and the National Driver Register.

The Highway Safety Act required each state to initiate a highway safety program and directed the governor of the state to assume responsibility for dealing with the federal government in matters pursuant to this act. Eighteen highway safety program guidelines were written; these have now been replaced by nine safety programs that are eligible for federal funding (Ref. 6):

Under NHTSA

Alcohol and other drug countermeasures  
Police traffic service  
Occupant protection  
Traffic records  
Emergency medical services  
Motorcycle safety

Under FHWA

Roadway safety

Jointly under NHTSA and FHWA

Pedestrian and bicycle safety  
Speed control

- 3 **The Transportation Equity Act: A Legacy for Users** (Ref. 7) governs federal policy and the activities of the U.S. Department of Transportation.

#### D. State and Local Legislation

- 1 Until 1966, the promulgation of laws concerned with street and highway traffic and regulations, except for vehicles engaged in interstate commerce, was left solely to the states. Since then, there has been some federal intrusion, using the threat of withholding grants when attempting to compel states to adopt certain laws (e.g., seat belt requirements). However, the states continue to exercise primary jurisdiction in the field.
- 2 Under authority delegated by the state, local governments are empowered to enforce state law within their corporate boundaries and to enact and enforce traffic regulations of local interest that are not in conflict with state law. Examples of delegated authority include:
  - a. Regulation of standing and parking of vehicles.
  - b. Regulation of traffic by traffic control devices in conformity with the state motor vehicle code.
  - c. Regulation of speed in conformity with the state code.
  - d. Designation of one-way streets, through streets, and truck routes.
  - e. Establishment of turn prohibitions.
  - f. Enforcement by police officers and parking personnel.

#### E. Uniform Traffic Legislation

- 1 **Uniform Vehicle Code (UVC)** (Ref. 1). The UVC is a specimen set of motor vehicle laws, designed as a comprehensive guide or standard for state motor vehicle laws. First drafted in 1926 by the (Secretary of Commerce) Hoover Conferences because inconsistent traffic laws were judged to be a prime impediment to highway safety, the Code has been revised periodically, most recently in 2000. It is given credence by Federal Highway Safety Program Standard #6, which requires that states compare their laws to the UVC and make efforts to resolve differences. The case is made that, while it is desirable to leave legislation affecting motor vehicle use in the hands of state legislatures, general traffic conditions in all states are so much alike that users of public streets and highways should expect to find uniform regulations: situations similar in nature should be treated similarly.

The UVC is promulgated by the National Committee on Uniform Traffic Laws and Ordinances, composed of more than 140 representatives of groups with an interest in achieving "sound, uniform motor vehicle laws and regulations" throughout the United States. The members are drawn from federal, state, and local governments and from business, industry, and professional societies. Their work is based on actual experience under various state laws throughout the nation.

The sections of the UVC of particular interest to the traffic engineer cover the following:

- a. Establishment and administration of a highway safety program (§ 2-101-103).

- b. Establishment and operation of a state department of motor vehicles (§ 2-301-314).
  - c. Registration of vehicles (Chap. 3).
  - d. Drivers' licenses (Chap. 6).
  - e. Financial responsibility (Chap. 7).
  - f. Accidents and accident reports (Chap. 10).
  - g. Rules of the road (Chap. 11).
  - h. Vehicle equipment (Chap. 12).
  - i. Vehicle inspection (Chap. 13).
  - j. Vehicle size, weight, and load (Chap. 14).
  - k. Respective powers of state and local authorities (Chap. 15).
- 2 **Model Traffic Ordinance (MTO)** (Ref. 1). This is a specimen set of ordinances prepared by the same National Committee for guidance in formulating local traffic regulations. Its main provisions include:
- a. Traffic administration:
    - (1) Traffic commission.
    - (2) Police functions relating to traffic.
    - (3) City traffic engineer.
  - b. Traffic rules (must have been delegated by the state):
    - (1) General provisions.
    - (2) Rules for drivers.
    - (3) Rules for pedestrians and passengers.
    - (4) Rules for stopping, standing, and parking.
    - (5) Parking meters.
  - c. Pedalcycle registration.
  - d. Penalties and disposition of fines and fees.

## F. Driver Licensing (Ref. 8)

Licensing of drivers has historically been a state function.

### 1 Purposes of Licensing.

Identification of drivers.

- a. Evidence of competence.
- b. Method of recording driver violations.
- c. Elimination of dangerous drivers by withholding, suspending, or revoking license.

### 2 Types of Licenses.

- a. Driver's license—permits the operation of motor vehicles on the highway. The class of license defines the types of vehicles that the holder is authorized to drive. The California Vehicle Code (CVC) defines Class C as the standard license covering passenger cars, small trucks, and small tows; a Class B license also covers buses and large single-unit trucks; a Class A license all large vehicles; and a Class M license motorcycles (Ref. 9, § 12804.9(b)).
- b. Instruction permit—allows persons to operate a vehicle under supervision of a licensed driver. Such permits are valid for from 2 to 24 months (24 months in California; Ref. 9, §12509(c)).
- c. Junior license—permits driving below minimum age under certain conditions, e.g., day-light only, to and from school only, on the farm only. California's "provisional" license is provided for in Ref. 9, §12814.6.
- d. Others—many states have commercial drivers licenses, school bus drivers' licenses, etc.

### 3 Issue of Licenses.

- a. Licenses are issued at the state level, but legal provisions vary. Through interstate compacts and the National Driver Register (Sec. 5.e. below), attempts are made to restrict each person to

one license (most states provide for this) and to bring reports of driver violations to the "home state" of the offender.

- b. The minimum age for standard driver's licenses ranges from 15 to 18, with junior licenses permitting restricted vehicle operation below the minimum age in 35 states (as low as 14 years old in eight states and only 13 for operating farm equipment on a public road in one state).
- c. Standard licenses are valid from two to five years (six in Maine), except in Arizona where they are valid from issue until the driver reaches the age of 60. Some chauffeur licenses must be renewed annually. California issues 5-year licenses (Ref. 9, § 12816). In most states, licenses expire on or near the holder's birthday.

#### 4 Tests for Applicants.

- a. *Written.* Most states give written examinations to test knowledge and, sometimes, judgment.
- b. *Oral.* Many states give oral tests to those unable to write; some give oral instead of written tests to all.
- c. *Physical.* All states test the vision of applicants for original licenses. Most also test color perception and hearing. Many states give vision tests when renewing drivers' licenses.
- d. *Driving.* All states give driving tests, though seldom for license renewal, except for drivers involved in accidents, or in response to complaints from relatives, neighbors, etc., if these complaints are determined to be reliable.

#### 5 Revocation, Suspension, and Restriction.

- a. Revocation (permanent unless the driver can eventually qualify for a new license), suspension (for a stated period), and restriction (driving restricted to necessary travel to, from, or at work) are used to reduce risk exposure by habitual and serious violators. They are difficult to enforce, since it is impractical to check every driver frequently. Offenders are caught only if involved in a subsequent violation or accident.
- b. All states have laws requiring automatic suspension or revocation for some or all of the following felonies: drunken driving, driving while drugged, hit-and-run driving, involuntary manslaughter, motor vehicle use in a felony, three convictions for reckless driving in a year, and failure to appear in court on other traffic violations cases. A restricted license is an occasional alternative in cases where suspension would create an extreme hardship. For California's law, see Ref. 9, Div. 6, Chap. 2.

TEA-21 provides incentive grants to states that make it illegal to drive with a blood-alcohol concentration (BAC)  $\geq 0.8$  g/L (0.08%). California (CVC § 13382) authorizes police in California to confiscate the licenses of adult drivers under this condition and of drivers less than 18 years old with BAC  $\geq 0.5$  g/L. The drivers' copy of arrest warrants function as 30-day temporary licenses; during this period they can appeal the license suspension, which is for six months on a first offense in seven years, for 2 years on subsequent offenses (§ 13352).

- c. All states have "implied consent" laws, requiring drivers to undergo chemical or other tests for alcohol or drugs in their systems. Implied consent means that, by the act of driving, an individual gives consent for these tests to be conducted. Refusal to take the tests results in mandatory license suspension or revocation in most states (some of which have "hardship exceptions") and in discretionary action in the other states.
- d. Driver violation records are maintained at the state level. The UVC specifies a point system to identify habitual offenders (Ref. 1, § 6-211). More than one half of the states are specifically authorized by law to use such a system; other states act administratively. California is among the former (Ref. 9, § 12810). Drivers are assigned varying numbers of points for each moving violation, depending on the seriousness of the offense. Those who accumulate a certain number of points in a stated period may be called before examiners for new license tests or sent to a special drivers' school. A still higher number of points may mean license suspension or revocation.

- e. The U.S. Department of Transportation maintains the National Driver Register that enables each state to obtain information on violations committed by its drivers in other states. Most states avail themselves of this service (Ref. 10).

## 6 Impact of Federal Legislation on State Driver Licensing Provisions.

- a. NHTSA has urged states to replace "operator's" and "chauffeur's" licenses with "driver's" licenses. It recommends that each driver hold only one license that identifies the classes of vehicles he/she is authorized to drive. The standard also specifies that drivers be reexamined at an interval not to exceed four years for at least visual acuity and knowledge of rules of the road.
- b. Actual compliance by the states is not uniform. Many states (including California) conform. In some of the others, it is only a matter of semantics since they prohibit an individual from holding both an operator's and a chauffeur's license. Nevertheless, about half the states permit an individual to hold more than one license, either from two different states or both from the "home" state. In 13 states all or some licenses are valid for more than the recommended term of four years.

## G. Rules of the Road

- 1 **Traffic Signs, Signals, and Markings.** Vehicle codes define significance of and obedience to traffic control devices. They restrict authority to place such devices, prohibit display of unauthorized devices and interference with those authorized.

- 2 **Motorists' Rights and Duties.**

- a. *Driving on Right Side of Roadway, etc.*
  - (1) Rules are given for driving on the right half of the roadway except when:
    - (a) Overtaking or passing.
    - (b) About to make a lawful left turn.
    - (c) Driving on roadways designated for one-way operation.
    - (d) Right half of roadway is closed for construction or repairs.
  - (2) Vehicles traveling at less than normal speed of traffic are required to keep as close to the right edge of the roadway as practicable.
  - (3) Codes provide procedures for normal overtaking and passing on the left. Passing on the right is allowed only under the following conditions:
    - (a) When overtaken vehicle is about to make a left turn.
    - (b) Upon a roadway with at least two moving lanes in each direction.
    - (c) Upon roadways designated for one-way operation.
    - (d) Codes also prescribe limitations to overtaking and passing at points of limited sight distance, prohibit following another vehicle too closely, etc.
- b. *Other Motorists' Rules.*
  - (1) Right of Way Rules. See Chap. 19.
  - (2) Speed Restrictions. See Chap. 22.
  - (3) Stopping, Standing, and Parking Regulations. See Chap. 23.
  - (4) Use of headlamps in darkness or inclement weather (e.g., Ref. 9, §24400).

- 3 **Pedestrians' Rights and Duties.** See Chap. 20.

- 4 **Bicyclists' Rights and Duties.** See Chap. 21.

## H. Vehicle Equipment and Inspection

- 1 The UVC and state codes establish minimum requirements for certain vehicle equipment including:

- a. Head and tail lamps and directional signals
  - b. Brakes
  - c. Horns and warning devices
  - d. Mufflers and smog control devices
  - e. Mirrors
  - f. Windshield wipers
  - g. Seat belts
- 2 The UVC provides for compulsory vehicle inspection at least annually to check on conformance with minimum equipment requirements. In California, CVC § 4000.1-4000.3 and Health and Safety Code § 44000 ff. provide for inspection of emission control devices and measurement of exhaust chemistry every other year for all vehicles registered and garaged in a "nonattainment area"-an air basin not attaining ambient air quality standards (see Chap. 30). Inspection of vehicle safety components by police officers if violations are suspected is also authorized.
  - 3 Under the Motor Vehicle Safety Act, the federal government issues specifications for motor vehicle safety standards. As of October 2004, 58 standards were in force, covering new motor vehicles, equipment, and fuels (Ref. 5). The standards deal with such items as vehicle control layout, windshields, brakes, lamps, tires and rims, theft protection, vehicle occupant protection (seat belts, door latches, padded dashboards, etc.), and fuel tanks. Revisions of these standards and additional standards are constantly under review, and occasionally a standard is abolished.
  - 4 The Air Quality Act of 1967 empowered the federal government to control vehicle emissions. The Act specifies that California, which has more stringent requirements than those established by the federal authorities, may continue to enforce these. (Federal involvement in all aspects of prevention, abatement, and control of environmental pollution was further extended by the Environmental Quality Improvement Act of 1970. See Chaps. 29-31.)

## I. Public Agencies' Legal Responsibility from a Traffic Engineer's Viewpoint\*

- 1 **Introduction.** Responsibility for traffic safety and traffic systems management begins with every state and local agency employee who, by virtue of his/her employment, operates these highway systems and may have opportunities for identifying and reporting traffic safety problems. In California, for example, provisions in the Government, Administrative, and Vehicle Codes combine to establish a clear framework for governmental responsibility and authority in developing and operating highway traffic systems. Whether the problem involves an overgrown shrub that obstructs a STOP sign, an unsigned sharp curve, or a deteriorated pavement, the legal obligation of the government employee with responsibility for the roadway who happens to pass by remains the same. Corrective action must be taken.

Public agencies and their employees used to rely on sovereign immunity for protection against being named as defendants in civil lawsuits concerning the design, operation, and maintenance of their highway system. Particularly since 1963, the law has changed so that both the agency and the individual administrator or employee may be found legally liable for all or a portion of damages awarded for loss under certain circumstances. When there is inadequate insurance coverage or assets of another civil defendant, the plaintiff now will look to a third party, such as a public agency, to try to find the "deep pocket" from which to recover his or her loss.

With the magnitude of verdicts ever increasing, the representatives of the public agency must know what their responsibilities are to the public as well as to their agency. This section of the chapter covers the extent of those responsibilities, what conditions can lead to lawsuits and how to develop programs to avoid suits or defenses if sued.

---

\* This section was written by Robert W. Crommelin, P.E., Consulting Traffic Engineer, Palm Desert, CA, and was reviewed by Philip J. Sugar, Assistant City Attorney, City of Los Angeles, in 2000. It is current as of 2000 only.

2 **California Government Code Provisions.** Most states use "basic negligence law" to determine liability. California, however, differs with regard to conditions where a government entity can be held liable.

- a. *Government Code § 835 - Conditions of Liability.* "Except as provided by statute, a public entity is liable for injury caused by a dangerous condition of its property if the plaintiff establishes that the property was in a dangerous condition at the time of the injury, that the injury was proximately caused by the dangerous condition, that the dangerous condition created a reasonably foreseeable risk of the kind of injury that was incurred, and that either:
  - (1) A negligent or wrongful act or omission of an employee of the public entity within the scope of his employment created the dangerous condition; or
  - (2) The public entity had actual or constructive notice of the dangerous condition under § 835.2 a sufficient time prior to the injury to have taken measures to protect against the dangerous condition."
- b. *§ 830 -Definitions and Guidelines.*
  - (1) A *dangerous condition* creates a substantial risk of injury when the facility is used with due care in a manner that can be reasonably foreseen.
  - (2) A condition is not dangerous because of failure to provide *regulatory* control devices (stop signs, speed limit signs, etc.). These are discretionary items.
  - (3) The public entity will be liable for failing to post a *warning* sign when a dangerous condition could be anticipated.
  - (4) One accident alone is not circumstantial evidence of a dangerous condition; prior accidents at the same location are circumstantial evidence.
  - (5) A public entity is not liable where weather conditions cause a dangerous condition, if there is inadequate time to warn or repair.
  - (6) Notice:
    - (a) Actual Notice—the government had actual notice and knew, or should have known, of the danger.
    - (b) Constructive Notice—the government did not know about the condition, but should have known because the condition existed for a long time and was obvious enough to be discovered through exercise of due care; i.e., through an inspection program.
- c. *Statutory Defenses* (Government Code, § 830.6, 835.2, and 835.4).
  - (1) Reasonable action or non-action. The government acted reasonably if it knew of a dangerous condition and took little or no action to correct it because the risk of injury was remote and the correction cost was great, or, similarly, if the cost of an inspection system was great and the danger was remote for unknown conditions.
  - (2) Design immunity. Where the political body or authorized public official approved or signed the plans and the highway was built according to those plans, no liability can be established. Design immunity, however, can not be used as a defense if:
    - (a) Conditions had changed (increase in traffic, etc.).
    - (b) The plan was incomplete (omitted some important design detail, such as super-elevation) which proved to be dangerous.
    - (c) There is negligence independent of design (failure to post a warning sign necessary for safe travel).
    - (d) A judge believes that no reasonable traffic engineer would have approved the design plans.

Where it is impossible for the government to know if a design is dangerous until it is put in operation, the government cannot say that it carefully weighed safety factors prior to approving plans. Then, the design safety defect must be corrected upon learning of it.



### 3 Ministerial vs. Discretionary Duties.

- a. *Ministerial Duty.* Normally, an agency and the individual are liable for damages to anyone injured by negligence or through omitting to perform a ministerial duty—one that is absolute, imperative, involving merely the execution of a set task (e.g., failure to replace a missing STOP sign, or to flag traffic properly through a construction zone). This also includes failure to meet statutory duties.
- b. *Discretionary Duty.* Where government powers are to be extended or withheld based upon judgment of the political body or the individual employee, there is no liability. This also applies to a situation where funding for improvements requires setting of priorities, although minimum or temporary actions to alleviate or warn of dangerous conditions should be instigated when possible.

### 4 Types of Damages.

- a. *Economic damages* are defined as objectively verifiable monetary losses, i.e., past and future medical expenses and loss of income.
- b. *Non-economic damages* are determined by a jury's subjective judgment. They include pain and suffering, emotional distress, and loss of consortium, among others.

### 5 Comparative Negligence.

In recent years the concept of contributory negligence has changed to one of comparative negligence. Where previously a plaintiff's contribution to the events of the accident could be used as a major part of a defense, the current concept asks the jury to decide how the responsibility of each party for the total damages suffered compared proportionally.

For example, a jury may find that the plaintiff was responsible for 25% of the damages, another driver for 25%, the public agency for 40%, and an individual employee for 10%. If a \$500,000 damage verdict was granted, the plaintiff would receive \$375,000 (75% of \$500,000). If the other defendant driver had no insurance or assets, the public agency and the individual employee would have to pay this amount and then try to collect from that defendant. In other words, the plaintiff gets her/his share in any case (primarily from the public agency). If the verdict is for the defense, the plaintiff gets nothing and must pay the court costs as well as other expenses attributable to her/his side of the case; public agencies can charge the plaintiff the costs of defending the lawsuit in this situation.

### 6 Effect of California Proposition 51.

Initiative Proposition 51 of 1986 enacted Civil Code § 1431.1 through 1431.5. Previously, under the "joint and several liability" doctrine, defendants found liable in a tort action were generally obliged to pay the entire amount of the judgment, regardless of their respective proportions of fault. Often, the least culpable but most solvent defendant was obliged to pay the full damages.

Economic damages continue to be subject to this doctrine. However, non-economic damages are now apportioned among defendants according to each defendant's percentage of fault, which must therefore be determined by the fact-finder (jury, judge, or arbitrator).

In multiple defendant cases, plaintiffs' attorneys will try to persuade jurors that the most solvent defendants are the most at fault for their clients' damages. The defendants' attorneys, on the other hand, will point their fingers at co-defendants and unserved or unknown tortfeasors to reduce their clients' percentage of fault.

### 7 23 United States Code § 409.

In 1991, as part of the Intermodal Surface Transportation Efficiency Act (ISTEA), the U.S. Congress enacted a statute to promote highway safety on roads using federal highway funds. The statute, as interpreted by public defendants, prevents the discovery and/or admission of any evidence relating to the investigation of safety on a roadway subject to a suit. Traffic volume counts, speed studies, accident history reports and investigations, surveys, and other documentation by highway agency engineers have been withheld from plaintiffs under this statute if the roadway is subject to a federally funded improvement project.

In 1996, Congress amended the statute to clarify that § 409 protects raw data and source documents collected for the states' Highway Safety Improvement Program in addition to the engineer's analysis and opinions.

Because these data can be helpful to defendants as well as plaintiffs, this statute has not been used on a frequent basis in the late 1990s. Even so, it should be considered as part of trial strategy.

## 8 Legal Procedures.

- a. *Claims and suits* against a public agency—procedures and statute of limitations.
  - (1) The *claim* is the first step in processing a tort action against a public agency. In California, claims must be filed within six months of loss. (Some exceptions—minors.)
  - (2) The public agency frequently declines the claim; it then notifies the plaintiff of its action.
  - (3) The plaintiff then must file a complaint (civil suit) within 6 months after the claim has been denied.
  - (4) "Discovery" cannot start until the suit is filed.
- b. *Discovery* is a process by which the plaintiff can obtain information from the public agency to prepare his/her case. In addition, the public agency can use interrogatories to better determine the plaintiff's theory of liability.
  - (1) Interrogatories—one of defending agency employee's first contacts with a suit will be to prepare Answers to Interrogatories and responses to a Notice to Produce documents.
  - (2) Depositions—questions by plaintiff's attorney with the agency employee's answers being under oath and taken down verbatim by a court reporter.
- c. *Court Testimony*.
  - (1) Agency employees should sit in on a trial to become familiar with the procedures.
  - (2) The agency's attorney should spend time with employees to work out all questions and answers prior to the trial.

## 9 Risk Control Programs to Protect Yourself, Your Agency, and the Public.

- a. High accident location identification and surveillance; have standards regarding when field investigation will occur.
- b. Feedback from field crews and police (reports of skidmarks, scrapes, knock-downs, frequent violations of overly restrictive controls).
- c. Day/night inspections of traffic control devices and the roadway system in general; look for problem areas.
- d. Adopt design/operating standards (of others or your own). Have them in writing and follow them. It is best to have your own standards if you need to revise them fairly often.
- e. Keep current on new techniques and practices.
- f. Conduct field studies to identify changing conditions—speeds, volumes, traffic control device observance, signal timing, etc.
- g. Keep good records (see Chap. 34).
- h. Talk to your agency's attorney so that you will understand:
  - (1) What areas or subjects under your control seem to be frequent sources of litigation.
  - (2) What the laws are concerning agency and personal liability.
  - (3) What insurance the agency has for your actions and your personal liability. (Most are self-insured these days.)
  - (4) Whether the agency will give you a personal indemnification guarantee in writing. (Doubtful, but certainly desirable.)

## J. Further Reading

For a comprehensive treatise on traffic law, see Ref. 11. Further information on public liability can be found in Refs. 12-16.

### REFERENCES

1. National Committee on Uniform Traffic Laws and Ordinances. *Uniform Vehicle Code and Model Traffic Ordinance*. Evanston, IL: 1992. *And Updates to the 1992 Uniform Vehicle Code*. 1998. And Revisions to UVC approved 1/11/00. 2000. Available at: [http://www.ncutlo.org/ami\\_info.html](http://www.ncutlo.org/ami_info.html).
2. U.S. Government. *Code of Federal Regulations*. Title 49, Parts 390-399. As of Oct. 2004.
3. U.S. Laws, Statutes, etc. *National Traffic and Motor Vehicle Safety Act of 1966*, Public Law 89-563, 1966.
4. U.S. Laws, Statutes, etc. *Highway Safety Act of 1966*, Public Law 89-564, 1966.
5. U.S. Government. *Code of Federal Regulations*, Title 49, Part 571. As of Oct. 2004. Available online at <http://www.access.gpo.gov/cgi-bin/cfrassemble.cgi?title=200449>.
6. U.S. Government. *Code of Federal Regulations*, Title 23, Part 1205.3. As of Apr. 2005. Available online at <http://www.access.gpo.gov/cgi-bin/cfrassemble.cgi?title=200423>.
7. U.S. 109th Congress. *Safe, Accountable, Flexible, Efficient Transportation Equity Act: A Legacy for Users or "SAFETEA-LU"*. H.R. 3, 2005. Signed into law 10 Aug. 2005.
8. National Highway Traffic Safety Administration. *Driver Licensing Laws Annotated*. Washington, DC: 1980, 245 p. Also: *Annual Supplement 1983*, 89 p.; *Digest of Motor Laws*. Heathrow, FL: American Automobile Association. 1994.
9. California Department of Motor Vehicles. *2005 Vehicle Code*. Sacramento: 2005. Available online at <http://www.dmv.ca.gov/pubs/vctop/vc/vc.htm>.
10. National Highway Traffic Safety Administration. "National Driver Register". *Code of Federal Regulation, Title 49, Chap, 303*. 2000. Available online at [http://www.nhtsa.dot.gov/nhtsa/Cfc\\_title49/ACTchap303.html](http://www.nhtsa.dot.gov/nhtsa/Cfc_title49/ACTchap303.html).
11. Fisher, Edward C. *Vehicle Traffic Law*. Evanston, IL, Traffic Institute, Northwestern University: 2nd Edition (revised by Robert H. Reeder), 1974. 339 pp.
12. Baerwald, J.E. "Traffic Administration. Part C - Legal Liability". *In Traffic Engineering Handbook*. 4th Edition. Englewood Cliffs, NJ: Prentice-Hall, Inc., 1992, p. 437-447.
13. Lewis, Russell M., Ph.D., P.C. *Managing Highway Tort Liability*. Synthesis of Highway Practice 206. Washington, DC: Transportation Research Board, 1994. 40 p.
14. *Tort Liability and Risk Management*. Transportation Research Circular 361. Washington, DC: Transportation Research Board, 1990. 140 p. (Contains good bibliography.)
15. Thomas, L.W., and J.C.Vance. *Liability of State Highway Departments for Design, Construction, and Maintenance Defects*. Washington, DC: Transportation Research Board, National Cooperative Highway Research Program, Research Results Digest 80. 1975. 49 p. And December 1992 Supplement. 10 p.
16. Vance, J.C. *Personal Liability of State Highway Department Officers and Employees*. Washington, DC: Transportation Research Board, National Cooperative Highway Research Program, Research Results Digest 79. 1975. 22 p.

## A. Definition and Background

- 1 **Traffic Management Defined.** Traffic management is a set of measures taken to achieve safe, efficient, and environmentally friendly movement of people and goods, usually with limited investments in new infrastructure. By the 1980s, the concept had developed to the point of trying to influence land development and travel demand, resulting in short-term and long-term planning becoming more closely associated with design and operational activities. By including day-to-day management and operations in an iterative process with planning, strategic management began to develop. Management now also addresses environmental issues, resource allocation, and a wide variety of traffic issues (Ref. 1).
- 2 **Evolution of Traffic Management.**
  - a. *Transportation System Management (TSM).* This concept was promoted in the 1970s as a means to improve traffic operation with short-term, low-capital traffic engineering and transit projects. It evolved from the Traffic Operations Program to Improve Capacity and Safety (TOPICS) created by the Federal Aid Highway Act of 1968. While effective, TSM alone was unable to keep pace with worsening congestion, although it remains a valuable part of the toolkit for addressing mobility and congestion problems.
  - b. *Transportation Demand Management (TDM).* Developed in the 1980s, TDM focuses on travel demand (influencing the traveler) rather than on transportation supply (changing infrastructure and services). Efforts emphasize eliminating peak period auto trips or shifting them to other routes or times. Implementation costs are often low, mostly administrative, with the private sector expected to play an important role.
  - c. *Traffic Calming.* Since the 80s and 90s, traffic management often has turned to traffic calming, "the combination of mainly physical measures that reduce the negative effects of motor vehicle use, alter driver behavior, and improve conditions for non-motorized street users." (Ref. 2) These measures are used mostly to preserve or enhance the livability of residential areas.
  - d. *Congestion Management System (CMS).* ISTEA and TEA-21 require that a CMS be implemented in all Transportation Management Areas (TMAs, urban areas with populations over 200,000). A CMS "provides for effective management of new and existing transportation facilities ... through the use of travel demand reduction and operational management strategies." (Refs. 3, 4) The concept pulls together all traffic management ideas and experience developed through the previous decades, in many instances enhanced with Intelligent Transportation System (ITS) features.

## B. Transportation System Management (TSM)

Traffic System Management (TSM) actions focus on more efficient use of existing transportation facilities and, in some cases, on measures to reduce the demand for vehicle trips, especially during peak periods. Although the measures overlap, TDM programs put increased emphasis on modifying the demand side of the equation (see C below).

Short-term operational measures promoted as TSM actions include:

### 1 Traffic operations improvement.

- a. Improved signal timing and coordination (see Chap. 16).
- b. Turn lanes and other minor capacity improvements (see Chaps. 19 and 24).
- c. Freeway surveillance, communication, and control systems (see Chap. 25).
- d. Designation of reliever routes in congested corridors.

### 2 Goods movement actions.

- a. Provision of off-street loading facilities (see Chap. 27).
- b. Restricted delivery and pickup times, including during peak hours.
- c. Truck parking regulation enforcement.

### 3 Pricing actions (parking charges and tolls, including time-varying tolls — see C.4.c below).

### 4 Paratransit services.

### 5 Transit route, schedule, management, and marketing improvements.

Additional remedies, which have become popular in recent years, include rapid incident response and freeway service patrols, often coordinated through traffic management centers (see E.4 below), scheduling of highway maintenance and construction to occur at nighttime (see Chap. 26, Sec. J), and improved access management (see Chap. 12, Sec. D.1.a.(2)(b)).

## C. Travel Demand Management (TDM)

Travel Demand Management (TDM) focuses on reducing the demand for vehicle-trips (e.g., through change of mode) or shifting the time when vehicle-trips are made. Some measures also reduce the overall number of person-trips (reduced trip generation). TDM measures may be short-range and low-cost, in which case they may be considered part of TSM, or longer-range with somewhat higher costs. A detailed 1993 summary of TDM and implemented examples are included in Ref. 5. The "Online TDM Encyclopedia" developed by the Victoria Transport Policy Institute provides extensive information explaining most of the related options (Ref. 6). Additional material is found in Refs. 7, 8.

- 1 **Definition.** TDM describes "a system of actions whose purpose is to alleviate traffic problems through improved management of vehicle trip demand. These actions, which are primarily directed at commuter travel, are structured to either reduce the dependence on and use of single-occupant vehicles, or to alter the timing of travel to less congested time periods." (Ref. 9, p.1)
- 2 **Approaches.** Since the focus is on commuter trip reduction or modification, TDM may involve employers and developers. Where a group of employers is involved, they may create a Transportation Management Association (TMA) to handle the implementation. Involvement may be voluntary, encouraged by incentives, or mandatory:
  - a. *Voluntary.* Employers or developers initiate TDM programs.
  - b. *Incentive.* Through local ordinances and incentives such as relaxed zoning standards, developers are encouraged to undertake TDM measures.
  - c. *Mandatory.* State or local laws require developers or employers to undertake TDM programs.

During the 80s and early 90s, mandatory Employer-Based Trip Reduction (EBTR) programs were implemented in California, generally in pursuit of regional air quality improvement. The programs were strongly criticized as too costly and ineffective, especially by the business community. State law prohibited mandatory EBTR programs in 1996. (Ref. 8)

### 3 Short-Range Strategies.

- a. *Carpools and Vanpools.* Employers (on their own or through a TMA) organize carpools (2 or more persons) and vanpools (7 to 15 persons), perhaps supplying vans to the latter or offering other incentives such as close-in and free parking. The goal is for commuters to change from driving alone to ridesharing. It must be recognized, however, that some shift between rideshare modes or from transit to pooling can result.
- b. *Transit Improvements.* Improvements are made to encourage transit use, including new and improved services, reduced wait time, reduced ride time, more efficient transit terminals, and employer-subsidized fares. In one aggressive approach, so far generally limited to university communities, "unlimited access" provides free transit rides funded by direct employer payments to the transit operators (Ref. 11).
- c. *Provisions for Pedestrians and Bicyclists.* Local government can provide pedestrian and bicycle facilities on streets (Chaps. 20 and 21). Employers can provide bicycle storage areas and, perhaps, showers. Facilities may be used for the primary mode, as a feeder mode to transit, or for circulation in an activity center (Ref. 12).
- d. *Parking Management.* Off-street parking under the control of developers or employers can be managed to encourage ridesharing or transit use. The most conveniently located spaces may be reserved for rideshare vehicles at reduced rates or offered free. The remaining spaces are charged at full market value. Since 1992, California law has required most medium-size and large employers who lease space for free or subsidized employee parking to offer "cash-outs," through which employees can take the money in lieu of subsidized parking as an incentive to rideshare or use transit (Ref. 13). A 1997 study of eight firms in Los Angeles documents the effectiveness for TDM of parking cash-out (see Ref. 14).
- e. *Changes in Work Hours.* Employers can influence commuters' times of travel by offering staggered work hours, unusual work weeks (e.g., four 10-hour days, nine days in two weeks), or "flextime"—flexible work hours. Many government agencies have used both staggered work hours and flextime. Ref. 15 offers some examples.
- f. *Telecommuting.* Firms can make arrangements for employees to work at or near their homes, with telecommunication links to the office. While this is not widespread at present, preliminary research indicates that savings in veh-km traveled and in "cold starts" can be substantial. Ref. 16 presents a discussion of the potential impacts of telecommuting. Ref. 15 provides some examples.
- g. *Miscellaneous Short-Range Actions.* Employers or TMAs can also enhance ridesharing and reduce trip making by such actions as providing emergency rides for employees who commute as passengers, on-site day care and fitness centers, and other on-site activities that would otherwise generate separate trips.

### 4 Medium-and Long-Range Strategies.

- a. *HOV Facilities.* Ridesharing can be encouraged by providing dedicated high-occupancy vehicle (HOV) facilities. This must, of course, be done as a part of regional highway system development. See Chaps. 24 and 25, and Refs. 17 and 18. Note that HOV facilities and other TDM-oriented infrastructure are specifically authorized by the ISTEA and TEA-21 legislation as projects eligible for federal Congestion Management and Air Quality (CMAQ) funds in non-attainment areas. (Ref. 19)
- b. *Land Use Planning Measures.* Demand can be reduced in the long run by land use plans through which jobs and housing are in balance within a reasonable proximity and where densities are high enough for mass transit to be effective. Published guidelines promote such transit-oriented developments (see Chap. 12, Sec. D.2.c.(4)).

- c. *Congestion Pricing and Value Pricing.* Charging higher prices for driving in locations and at times when demand is heaviest and the congestion potential is greatest can help control congestion. Mandatory downtown congestion pricing has been implemented in some cities, such as London and Singapore (Refs. 20 and 21). In the U.S., pricing innovation has taken the form of "value pricing," an approach that provides optional toll facilities bypassing free but congested highway sections, as well as off-peak and shoulder discounts on toll facilities to encourage shifts in trip times. High-Occupancy Toll (HOT) lanes, where low occupancy vehicles may pay to use excess capacity on HOV facilities, such as on I-15 north of San Diego, typify this approach (Ref. 22). Refs. 23-26 present overall issues and experiences with congestion pricing in the U.S. and other countries.
- 5 **Evaluation.** TDM has proven to be effective, particularly when voluntary cooperation occurs between the private and public sectors. The magnitude of success depends on the particular programs implemented and the size of the affected population. Refs. 5, 7, and 8 discuss methods of evaluation and results of specific case studies.

## D. Traffic Calming

### 1 General.

- a. *Problem.* As discussed in Chap. 12, Sec. D.2, local streets are designed to provide access to abutting land. Typically, traffic volumes are low, speeds are moderate to slow, and destinations are to and from abutting buildings. However, some neighborhoods, particularly those with grid street patterns, may experience excessive through traffic movements, such as when adjacent arterials are congested, or if nearby land uses are office or commercial, causing related parking to overflow onto local streets.

Traffic calming is used to mitigate these problems. Refs. 27 and 28 provide comprehensive guides to traffic calming practice in the U.S. Ref. 29 is an overview of U.S. experience with traffic calming through the 1990s.

- b. *Objectives.*
- Eliminate potential accidents.
  - Minimize pollution and noise.
  - Recapture urban space for people.
  - Achieve harmony in scale and appearance.
- c. *Types of Calming Devices* (see D.2. below for specific designs).
- To reduce speed: slow points, chokers, circles, speed humps and "platforms."
  - To reduce volumes: half and full diverters, barriers.
  - To restrict non-resident parking: residential parking permit programs (see Chap. 23).
  - Exterior to neighborhood: capital improvements to reduce congestion on arterials.
- d. *Objections to Traffic Calming.*
- Total VKT (vehicle-km traveled) may increase.
  - Local air pollution may increase.
  - Adjoining arterials may become overloaded.
  - Emergency vehicles may be impeded.
  - Services may become less efficient.
  - Minor vehicle damage and accidents may result.
  - The frustration level of drivers may increase.
  - The beneficial flexibility of a grid network is eliminated.

### 2 Calming Designs.

- a. *Midblock design* can be modified to slow traffic, see Fig. 34-1 (Ref. 30). See Chap. 22 for details on speed humps.

b. Intersection design, see Fig. 34-2 (from Ref. 31):

- *Chokers* (Fig. 34-2A) reduce the widths of intersection approaches. They ensure that cars cannot park near intersections, provide locations for traffic signs closer to the approaching traffic, and enhance pedestrian safety by reducing the lengths of crosswalks.
- *Traffic circles* (Fig. 34-2B) force vehicles to slow down by bending the direction of flow. Approaches require centerline markings to guide vehicles toward the right as they enter the intersection. All turning movements are still possible. This treatment is neither a rotary intersection nor a roundabout.
- *Diverter* (Fig. 34-2C, D) convert an intersection into two unconnected streets, each containing a sharp turn. Simple diverters are constructed of guardrail. More elaborate projects involve new curbs, landscaping, and drainage structures.
- *Approach and exit closures* can be partial (Fig. 34-2E) or full (Fig. 34-2F). They are usually applied at the intersection of a minor street with an arterial. Partial closures restrict the number of entrances into a neighborhood without reducing the number of exits, and preserve maximum access for emergency vehicles. Full closures create cul-de-sacs; turnaround areas should be provided.
- *Calming measures with temporary construction* are usually tried first to determine impacts and unexpected problems. Once a measure is considered effective, more permanent construction may be implemented.

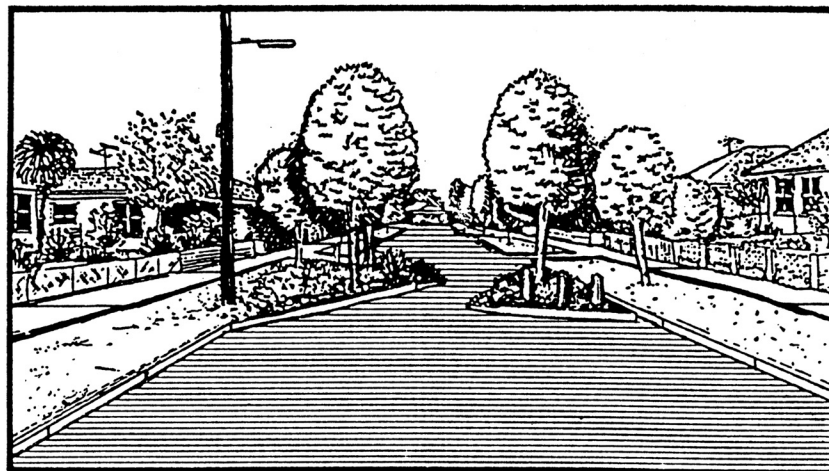
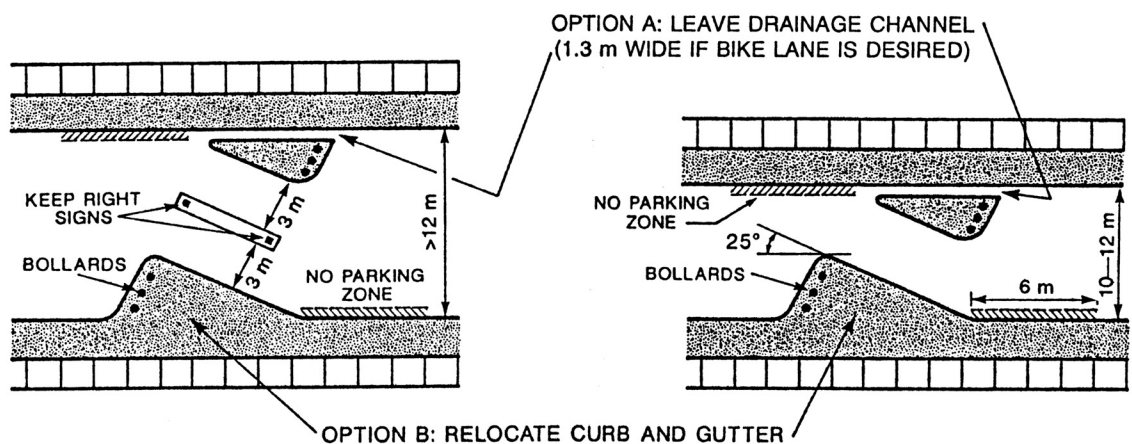

Fig. 34-1 Midblock "Slow Points" for Local Residential Streets



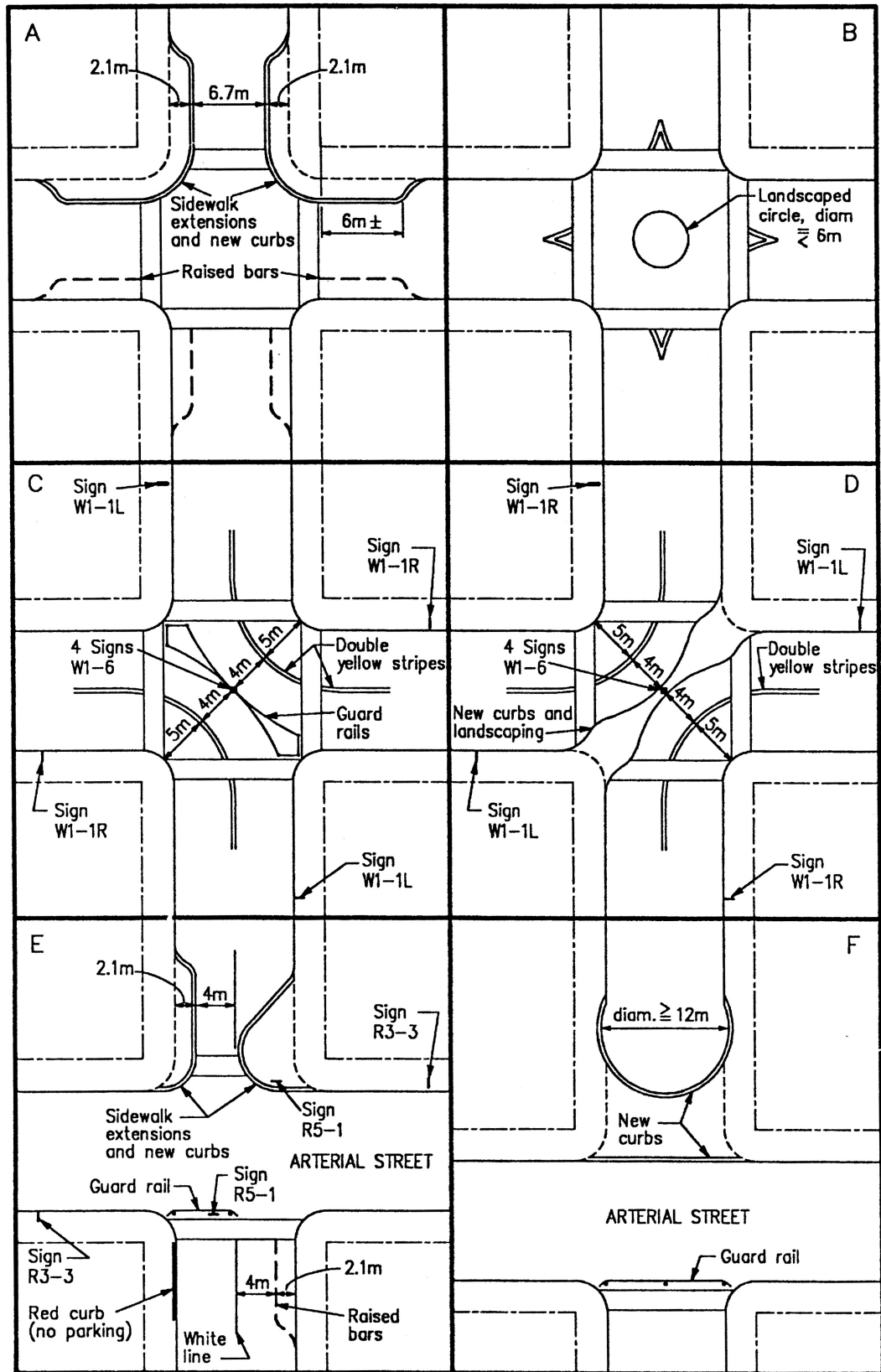

Fig. 34-2 A-F Treatment of Minor Intersections in Traffic Calming Schemes (Source: Ref. 31)

### 3 Examples for Residential Neighborhoods.

- Bellevue, WA: The Neighborhood Traffic Control Program started in 1985 with a two-phase program. Phase I concentrated on education and enforcement, including a safety campaign and a neighborhood speed watch program. For sites where this proved ineffective after six months, implementation of physical devices followed in a Phase II. This was needed in only 10% of the Phase I projects undertaken. A matrix of different methods with limited warrants was developed. (Ref. 32)
  - San Buenaventura, CA: Street closure, from 7:30 am to 4:30 pm, was implemented next to a high school. However, it generated controversy over the perception that a "public" facility was being closed. A Petition Review process was developed to satisfy legal requirements. (Ref. 33)
  - Howard County, MD: To deter speeding in a residential area, speed humps, traffic circles, roundabouts, and parallel chokers were used for traffic calming. (Ref. 34)
- 4 **Further Reading.** Refs. 35 and 36 are classic references on traffic calming in residential and commercial neighborhoods. The ITE maintains an on-line traffic calming library at: <http://www.ite.org/traffic/>.

## E. Congestion Management Systems (CMS)

- 1 **Purpose.** In the past, when congestion began to occur, the conventional solution was to build more roads. Because of political, financial, and environmental issues, this is often no longer practical. As noted in A.2.d., ISTEA and TEA-21 mandate the development of CMS.
- 2 **Congestion and Control.** Congestion can be categorized as either recurring (e.g., peak periods or regular events) or nonrecurring (unpredictable events, e.g., incidents, emergency maintenance, and weather). Control methods can be divided into two categories:
- a. *Demand-side.* Reduce vehicle demand through TDM and information dissemination.
  - b. *Supply-side.* Increase and preserve transportation system capacity through traffic control techniques.

Ref. 37 provides a discussion of the measures and impacts.

Intelligent Transportation System (ITS) technologies provide an evolving set of tools to help traffic professionals address both the demand and supply sides of the problem. See Ref. 38 for an overview of ITS issues and initiatives.

- 3 **California.** Each of the 31 urban counties in California was required to create a Congestion Management Agency (CMA) and to prepare and monitor a Congestion Management Plan (CMP) as a condition of receiving a share of Proposition 111 revenues approved by the voters in 1990. The legislative intent for requiring CMPs was expressed as follows:
- To make the most effective use of all transportation modes (highways, streets, and roads, rail, bus, bicycle, and pedestrian travel) in managing congestion through the CMP process.
  - To require local jurisdictions to examine the impact of land use decisions on the regional transportation system and be responsible for mitigating these impacts.
  - To develop transportation solutions that also work toward improving air quality.

San Jose State University completed a study of the CMPs and found that effectiveness was reduced when agencies had too many different functions in the plans (Ref. 39). Ref. 40 gives a summary of what CMPs entail.

- 4 **Traffic Management Centers (TMC).** Some state DOTs and cities have invested in urban and regional TMCs. Personnel of the highway agency, the traffic enforcement agency, or both staff a TMC. Some major transit agencies have control centers that are similar to highway TMCs, and true multimodal TMCs may become common in the future. An NCHRP synthesis describes how such centers typically operate. (Ref. 41) ITE, FHWA and AASHTO have developed a *Traffic Management Data Dictionary* to shape the development of future communications for TMCs consistent with the ITS National System Architecture. (See Refs. 42 and 43.)

In California, Caltrans and the California Highway Patrol jointly operate an extensive network of coordinated TMCs whose continuing development is described in the statewide TMC Master Plan. (Ref. 44)

#### REFERENCES

1. Weiner, Edward. *Urban Transportation Planning in the United States: An Historical Overview - Revised and Expanded Edition*. Praeger Publishers, Westport CT. 1999. (Previous fifth edition, Washington, DC: U.S. Department of Transportation, Report DOT-T-93-02, Sept. 1997. On-line. Internet. September 2004. Available: <http://tmip.fhwa.dot.gov/clearinghouse/docs/utp/>).
2. Lockwood, I.M. "ITE Traffic Calming Definition." *ITE Journal*, July 1997, p. 23-24.
3. U.S. Government. *Intermodal Surface Transportation Efficiency Act of 1991*. Public Law 102-24. Dec. 18, 1991. Internet. September 2004. Available: [http://iti.acns.nwu.edu/clear/infr/istea\\_lst.html](http://iti.acns.nwu.edu/clear/infr/istea_lst.html).
4. *Federal Register*. Vol. 65, no. 36, p. 9040-9053. Feb. 23, 2000. On-line. Internet. Sept. 2000. Available: [http://frwebgate.access.gpo.gov/cgi-bin/getdoc.cgi?dbname=2000\\_register&docid=fr23fe00-98](http://frwebgate.access.gpo.gov/cgi-bin/getdoc.cgi?dbname=2000_register&docid=fr23fe00-98).
5. COMSIS Corporation. *Implementing Effective Travel Demand Management Measures, A Series on TDM*. Washington DC: Institute of Transportation Engineers. June 1993. 391 p.
6. Victoria Transport Policy Institute. *Online TDM Encyclopedia*. Victoria, Canada: updated July 2004. On-line. Internet. October 2004. Available: <http://www.vtpi.org/tdm/>.
7. COMSIS Corporation. *A Guidance Manual for Implementing Effective Employer-Based Travel Demand Management Programs*. Washington, DC: FHWA. Rept. DOT-T-94-05. Nov. 1993. 113 p. On-line. Internet. Oct. 2004. Available: <http://ntl.bts.gov/DOCS/474.html>.
8. Turnbull, Katherine F. and Neil F. Lindquist, Editors. *Travel Demand Management Innovation and Research Symposium: Setting As Strategic Agenda for the Future*. Washington, DC: Transportation Research Board. Transportation Research Circular No. 433, Oct. 1994, 150 p.
9. COMSIS Corporation, with Harold Katz & Associates. *Evaluation of Travel Demand Management to Relieve Congestion*. Washington DC:, U.S. FHWA. Rept. DOT-T-90-14. Feb. 1990, 152 p.
10. Dell, Jennifer. "Mandatory Employer-Based Trip Reduction - What Happened?" Washington, DC: Transportation Research Board. *Transportation Research Record 1618*, 1998, pp. 103-110.
11. Brown, D., Hess, B. and Shoup D. "Unlimited Access." *Transportation*, Vol. 28, pp. 233-267, 2001. On-line. Internet. Oct. 2004. Available: <http://www.sppsr.ucla.edu/its/research/UA/UA.pdf>.
12. Dunphy, R. T. "Activity Centers." Chap. 15 in Edwards, J. D., Jr. (Editor). *Transportation Planning Handbook*. Second Edition. Washington, D.C.: Institute of Transportation Engineers, 1999.
13. Institute of Transportation Studies. "New Report on Parking Cash-Out Law." *ITS Review On-Line*. Vol. 1, No. 1: July 2002. Internet. Oct. 2004. Available: [http://www.its.berkeley.edu/publications/ITSReviewonline/july2002/parking\\_cashout.html](http://www.its.berkeley.edu/publications/ITSReviewonline/july2002/parking_cashout.html).
14. Shoup, D. "Evaluating the Effects of Cashing Out Employer-Paid Parking: Eight Case Studies." *Transport Policy*, Vol. 4, No. 4, pp. 201-216, 1997. Internet. Oct. 2004. Available: <http://www.sppsr.ucla.edu/dup/people/faculty/Shoup%20Pub%201.pdf>.
15. Rutherford, G. Scott, et al. "Transportation Demand Management: Case Studies of Medium-Sized Employers." *Transportation Research Record 1459*, 1994. pp. 7-16.
16. Ritter, Gary, and Stan Thompson. "The Rise of Telecommuting and Virtual Transportation." *Transportation Quarterly*, v. 48, n. 3, summer 1994. pp. 235-248.

17. Transportation Research Board. *Development of an HOV Systems Manual*. Washington, D.C.: National Cooperative Highway Research Program, 1998. NCHRP Report 413, 45 p.
18. Transportation Research Board. *HOV Systems Manual*. Washington, D.C.: National Cooperative Highway Research Program, 1998. NCHRP Report 414, 721 p.
19. 42 U.S. Code, Sec. 7408. Updated 1999.
20. Littman, T. *London Congestion Pricing: Implications for Other Cities*. Victoria, Canada: Victoria Transport Policy Institute, Feb. 18, 2004. Internet. Oct. 2004. Available: <http://www.vtpi.org/london.pdf>.
21. Keong, C.K. *Road Pricing: Singapore's Experience*. Brussels: Imprint-Europe, European Economic Commission, Oct. 2002. Internet. Oct. 2004. Available: [http://www.imprint-eu.org/public/Papers/IMPRINT3\\_chin.pdf](http://www.imprint-eu.org/public/Papers/IMPRINT3_chin.pdf).
22. Perez, B.G., Sciara, G-C. *A Guide for HOT Lane Development*. Washington DC: FHWA, Report FHWA-OP-03-009, March 2003, 112 p. Internet. Oct. 2004. Available: [http://ntl.bts.gov/card\\_view.cfm?docid=12411](http://ntl.bts.gov/card_view.cfm?docid=12411).
23. Small, K.A. and J.A. Gomez-Ibañez. *Road Pricing for Congestion Management : a Survey of International Practice*. NCHRP Synthesis of Highway Practice 210. Transportation Research Board. Washington DC: National Academy Press, 1994.
24. Higgins, Thomas J. "Congestion Pricing: Implementation Considerations." *Transportation Quarterly*, v. 48, n. 3, Summer 1994. pp. 287-298.
25. "Value Pricing Pilot Program." *TR News*. No. 204. Sept.-Oct. 1999. Washington, D.C.: Transportation Research Board.
26. Sullivan, E.C. "Implementing Value Pricing for U.S. Roadways." *European Journal of Transport and Infrastructure Research*. Vol. 3, No. 4, pp. 401-413, 2003. Internet. Oct. 2004. Available (original paper): [http://www.imprint-eu.org/public/Papers/imprint\\_Sullivan%20US\\_final.pdf](http://www.imprint-eu.org/public/Papers/imprint_Sullivan%20US_final.pdf).
27. Ewing, R.H. *Traffic Calming: State of the Practice*. Washington DC: Institute of Transportation Engineers and U.S. FHWA, Report FHWA-RD-99-135, 1999, 244 p. Internet. Oct. 2004. Available: <http://www.trafficcalming.org/>.
28. U.S. FHWA. *Traffic Calming*. Washington DC: U.S. Dept. of Transportation, last updated 2001. Internet. Oct. 2004. Available: <http://www.fhwa.dot.gov/environment/tcalm/>.
29. Knapp, Keith K. "Traffic-Calming Basics." *Civil Engineering*, Volume 70, number 1, January 2000. Reston, VA: American Society of Civil Engineers, pp. 46-49.
30. Homburger, Wolfgang S. et al. *Residential Street Design and Traffic Control*. Englewood Cliffs, NJ: Prentice-Hall, 1989. 152 p.
31. Sinemus, Herman. *Neighborhood Traffic Controls*. Berkeley, CA: Paper presented at the 25th Annual Meeting, Western Section Institute of Traffic Engineers. July 1972.
32. Gonzalez, Karen L. "Neighborhood Traffic Control: Bellevue's Approach." *ITE Journal*, May 1993. p. 43-45.
33. Elizer, Jr., R. Marshall, and Nazir Lalani. "Facing Up to a Street Closure Epidemic." *ITE Journal*, October 1994. p. 24-28.
34. Walter, C. Edward. "Suburban Residential Traffic Calming." *ITE Journal*, September 1995. p. 44-48.
35. Appleyard, Donald. *Livable Streets*. Berkeley, CA: University of California Press, 1981.
36. Moudon, Anne Vernez, Ed. *Public Streets for Public Use*. New York: Columbia University Press, 1991.
37. Strickland, Sheldon G., and Wayne Berman. "Congestion Control and Demand Management." *Public Roads*, Winter 1995. pp. 1-7.

38. U.S. FHWA. *Welcome to the Intelligent Transportation Systems*. Internet. Oct. 2004. Available: <http://www.its.dot.gov/>.
39. Colman, Steve. "California Study of Successful Congestion Management Programs." *ITE Journal [Congestion Management News]*, January 1995, p. 35.
40. Congestion Management Program Task Force. *Congestion Management Program - Resource Handbook*. Sacramento, CA: Nov. 1990, 58 p. + Apps.
41. Kraft, Walter H. *Transportation Management Center Functions*. National Cooperative Highway Research Program. Synthesis of Highway Practice 270. Washington, DC: 1998.
42. Institute of Transportation Engineers. *Traffic Management Data Dictionary (TMDD) and Message Sets for External Traffic Management Center Communications (MS/ETMCC)*. Washington DC: 2004. Internet. October 2004. Available: <http://www.ite.org/tmdd/>.
43. U.S. Department of Transportation. *Version 5.0 of the ITS National Architecture*. Washington DC: updated 4/2004. Internet. October 2004. Available: <http://www.its.dot.gov/arch/arch.htm>.
44. California Department of Transportation, California Highway Patrol. *TMC Master Plan*. Sacramento, CA: Caltrans Program of Traffic Operations, December 1997.

## A. Responsibility for Traffic Engineering Functions

- 1 The responsibility for traffic engineering and related functions is often distributed among many agencies at all levels of government. Therefore, it is important to:
  - a. Provide clear-cut lines of authority and avoid duplication of effort and confusion as to who is responsible.
  - b. Consolidate related functions to improve effectiveness in dealing with traffic engineering problems and recommending solutions.
  - c. Assure smoothly functioning intergovernmental relations, so that problems affecting several agencies can be dealt with responsibly.
- 2 Agencies with responsibilities in traffic engineering and related fields include:
  - a. Federal: FHWA and NHTSA within the U.S. Department of Transportation—overview functions, funding, and standards (e.g., *MUTCD*). Some federal agencies administer highway operations on federal lands (e.g., national parks, military bases.)
  - b. State: transportation department, highway police, motor vehicle department, public utilities commission—state highway system, enforcement, licensing, and safety.
  - c. City and county agencies: police, public works (geometric design of new facilities, street maintenance, electrical, and lighting), city planning, city attorney, the courts, the city council, commissions, schools, etc., and, of course, the traffic engineering agency itself.
- 3 The responsibility for traffic engineering functions is most commonly assigned to a traffic engineer in the public works (engineering) department, sometimes to a separate department. Organization at the state level is discussed next, that of local agencies in Secs. C and D.

## B. Organization for Traffic Engineering at the State Level

State Departments of Transportation (DOTs) are generally organized into a headquarters office in the state capital and a number of district offices covering the state. At both the headquarters and district levels, traffic engineering is likely to be housed in "divisions" whose responsibilities are outlined below:

- 1 **Traffic Engineering Responsibilities at Headquarters Level.**
  - a. *Compliance.* Assure that there is compliance with federal and state transportation goals, policies, regulations, and standards.
  - b. *Data Collection and Reports.* Collect statewide traffic volume and speed trends, accident data (if not collected by the state highway police), and the like and publish appropriate reports.

- c. *Statewide Studies.* Conduct studies of statewide interest and publish reports. This includes studies of future needs to enhance safety, reduce congestion, and reduce adverse environmental impacts related to traffic flow on the state highway system.
- d. *Research.* Perform research on problems of statewide interest, on materials, devices, operation and control methods, and on the effectiveness of programs implemented by the agency.
- e. *Develop and Adopt Standards.* Based on studies and research, in coordination with local governments and other interested transportation groups, develop and promulgate new standards for traffic control equipment and devices and for materials used in these devices. Assure compliance with federal standards.
- f. *District Coordination and Supervision.* Approve requests from district traffic engineering division, issue new guidelines and procedure manuals for the districts, and advise districts on specific problems.

## 2 Traffic Engineering Responsibilities at the District Level.

Districts are responsible for the safe and orderly flow of traffic on state highways within their assigned territories. Districts covering major metropolitan areas will have more complex duties and hence more elaborate organizations structures and are detailed here. The organization in rural districts is somewhat simpler.

- a. *Traffic Engineering.*
  - Conduct traffic investigations; devise corrective measures for traffic problems; establish no-parking and speed zones; conduct safety reviews.
  - Prepare plans, specifications, and estimates for highway signals, lighting, and signing; review work proposed by others to be done on state highways under encroachment permits.
  - Conduct accident surveillance and maintain a complete file of reported accidents on state highways; provide accident data to others; and perform speed zone surveys.
  - Plan signalized intersections; set timing for state-maintained signals; test cabinets and controllers; and monitor the operation of signalized intersections.
  - Respond to emergency situations and public complaints.
  - Deal with staffs of other public agencies, private citizens, consultants, contractors, etc.; give expert witness testimony in depositions and tort liability actions; provide assistance to state attorneys in handling claims against the state.
- b. *Highway Operations.*
  - Monitor traffic and person-carrying performance of the existing highway system in terms of quantity and quality of traffic flow.
  - Plan and recommend operational projects and activities to improve the performance of the existing transportation system.
  - Provide support to the district in terms of evaluating operational impacts for various state projects, local and private development proposals, and special requests.
  - Conduct the annual census program of traffic counting.
  - Develop traffic management plans for construction and maintenance projects.
- c. *Traffic System Management.* In a metropolitan area, develop a Traffic Operations System (TOS) and a regional ramp metering system; design electrical elements of traffic management system projects; manage traffic in response to major incidents and special events; operate the regional TOS; direct the project management and program management activities for the district.

## C. Organization and Staffing in Cities and Counties

- 1 Table 35-1 shows where the primary responsibility for traffic engineering functions is located within 125 city and urbanized county governments surveyed in 1994.

**Table 35-1 — Primary Responsibility for Traffic Engineering Functions**

	Agency with Primary Responsibility for Listed Function										Not Stated or Not Applicable	
	Traffic Engr Agency	Public Works Dept.	Streets or Highways Dept.	Police Dept.	Parking Agency	Planning Dept.	Other*					
<b>Traffic Control Devices</b>												
Design	88%	5%	1%	0%	0%	0%	2%	4%				
Installation	66	19	7	0	0	0	1	7				
Operation	75	9	3	1	0	0	2	10				
Maintenance	65	20	7	0	0	0	2	6				
<b>Traffic Laws &amp; Ordinances</b>												
Propose	77	3	1	12	0	1	4	2				
Review Proposals	73	5	1	12	0	1	5	3				
<b>Traffic and Accident Data</b>												
Conduct Traffic Surveys/Counts	81	8	1	0	0	1	4	6				
Maintain Traffic Database	80	5	1	1	0	1	6	6				
Collect Accident Data	56	3	1	29	0	0	7	4				
Maintain Accident Database	62	3	1	23	0	0	7	4				
<b>Street and Highway Improvements</b>												
Operations Review	83	6	1	1	0	1	3	5				
Traffic Control Plans	80	9	1	2	0	0	3	5				
Propose Safety Improvements	82	9	1	1	0	1	3	3				
Design Safety Improvements	61	22	4	1	0	0	6	6				
Implement Improvements	43	37	10	0	0	1	6	3				
<b>Parking</b>												
Administration	38	5	1	3	17	4	10	22				
Build Facilities	15	26	3	1	14	3	9	29				
Install Meters	31	6	3	1	9	0	0	8				
Collect from Meters	25	1	3	4	13	0	12	42				
Enforce Regulations	13	2	1	51	13	1	2	17				
<b>Planning</b>												
Participate in Urban Planning Process	57	9	2	0	0	16	7	9				
Review Site Plans	66	12	1	0	0	11	5	5				
Review Development Proposals	64	12	1	0	0	12	5	6				
Provide Data	66	6	1	1	1	11	5	9				
<b>Transit</b>												
Administer Operations	9	9	0	0	2	1	42	37				
Operations Reviews	34	5	0	0	2	1	27	31				

Source: Ref. 2, Table 4.3

\* - Including MPOs and State DOTs.  
 NOTE: Some rows do not add to 100% because some respondents did not complete all data items.



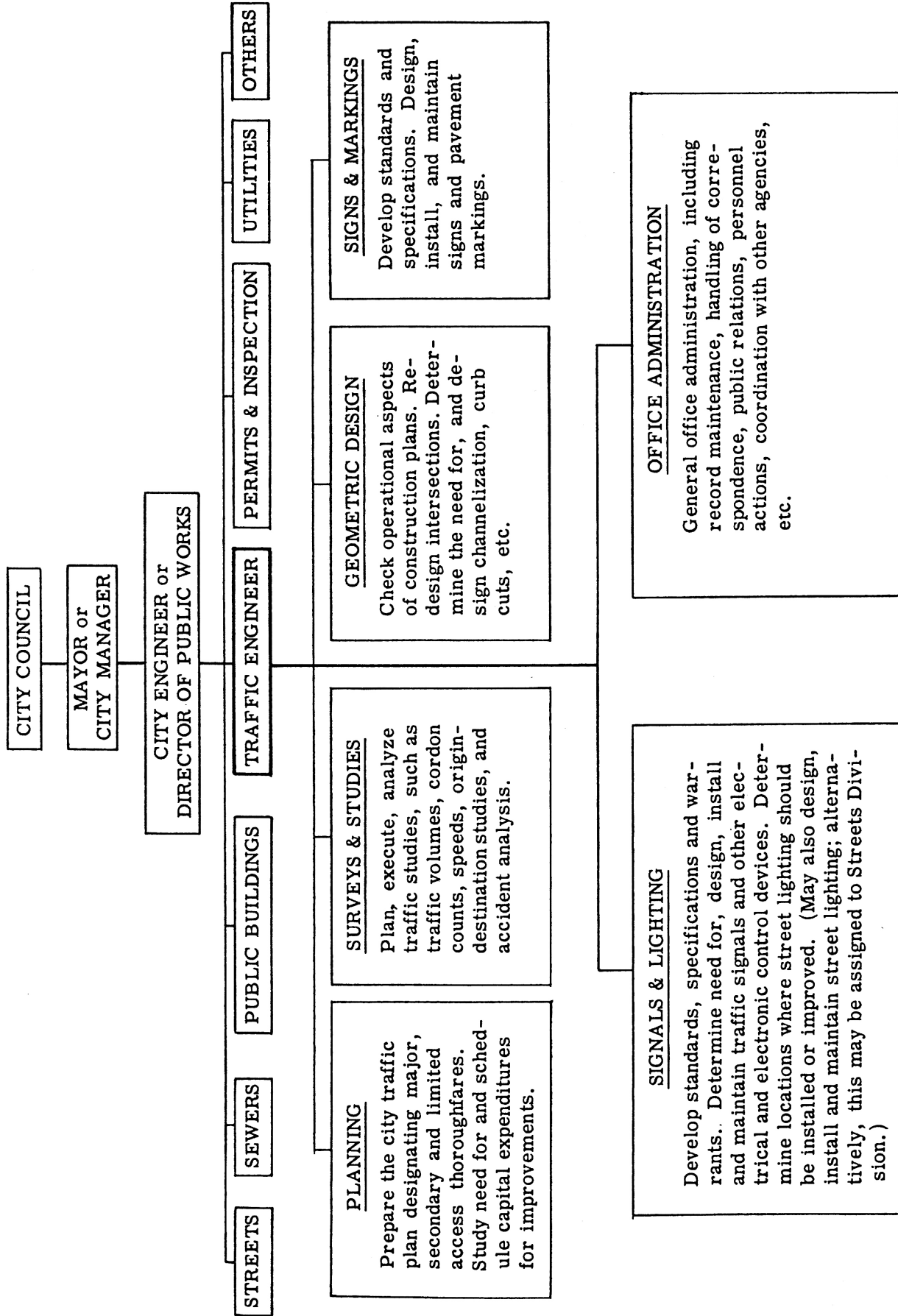

Figure 35-1 — Typical Functional Organization Chart for Traffic Engineering in Cities

Small cities and counties sometimes find it advantageous to retain consulting engineers to perform traffic engineering tasks; some may arrange by contract to have a larger city or county handle these duties. Cities with traffic engineers sometimes engage consultants for special traffic studies. In some states, automobile clubs have engineering staffs available to perform such functions for small communities, either informally or under contract. The services of the state DOT's traffic engineering division may also be available.

- 2 A typical organization chart for a traffic engineering division in a large city government is shown in Fig. 35-1. A similar arrangement can be used for counties with major traffic engineering responsibilities. The same principles apply in smaller cities and counties, but there will be considerable consolidation of sections shown separately in the figure, even to the point of one engineer performing or supervising all the functions shown on a part-time basis.

In some cases, traffic engineering is a separate department, whose chief reports directly to the mayor or city or county manager. Ancillary functions, such as operation of parking facilities, on-street parking enforcement, and installation and maintenance of lighting systems may also be included.

- 3 The responsible traffic engineer is often a registered engineer or a graduate of an engineering college. The survey of 125 agencies conducted in 1994 (Ref. 2) found that 98% required a bachelor's degree and 16% a master's degree for the senior level professional; engineering registration is specified in 53% of these agencies for the senior position.
- 4 Professional and technician staffing levels per capita in cities generally decline as city size increases. Table 35-2 shows the results from 125 survey respondents. The mean values for professional staffs in all responding agencies were 3.2 professionals and 4.1 technicians per 100,000 population.

**Table 35-2—Traffic Engineering Agency Staffing, 1994**

	Average Number of Personnel per 100,000 Population				
	Cities, by Population Group				Counties
	<50,000	50,000 - 100,000	100,000 - 250,000	>250,000	
Professionals	12.3	6.7	5.0	2.7	2.4
Technicians	7.4	5.5	2.8	4.0	2.1
Programmers	0	1.4	0.6	0.2	0.2
Drafters	1.1	5.6	1.0	0.3	0.4
Maintenance	7.5	11.2	11.5	10.0	5.4
All employees*	28.7	32.4	22.8	18.5	11.3
Number of responses	22	28	35	12	23

Source: Derived from Ref. 2, Table 4.14 and Appendix D.

\* - Includes administrative employees not shown above

## D. Legal Authority for Traffic Engineering Actions in Cities and Counties

County and city ordinances prescribe the authority and responsibility for traffic engineering actions. The Model Traffic Ordinance (MTO - Ref. 3) and the Uniform Traffic Ordinance of the League of California Cities (Ref. 4) suggest legal provisions for cities and may also be used by counties. The following referenced sections are all from Ref. 3.

### 1 Assignment of Responsibility.

- a. *Full-time traffic engineer:* "The office of (city) traffic engineer is hereby established. The (city) traffic engineer shall be a qualified engineer and shall be appointed by \_\_\_\_\_ (under civil service) and shall exercise the powers and duties as provided in this ordinance and in the traffic ordinances of this (city)." (§ 32-301(a))
- b. *Part-time traffic engineer:* "The office of (city) traffic engineer is hereby established. The (city engineer) shall serve as (city) traffic engineer in addition to other functions, and

shall exercise the powers and duties with respect to traffic as provided in this ordinance."  
(§ 32-301(a) ALTERNATE)

- c. *General description of duties:* "It shall be the general duty of the (city) traffic engineer to determine the installation and proper timing and maintenance of official traffic control devices, to conduct engineering analyses of traffic accidents and to devise remedial measures, to conduct engineering investigation of traffic conditions, to plan the operation of traffic on the streets and highways of this (city), and to cooperate with other (city) officials in the development of ways and means to improve traffic conditions, and to carry out the additional powers and duties imposed by ordinances of this city." (§ 32-301(b))

- 2 **Specific Authorizations.** Traffic engineering actions are assigned specifically to the traffic engineer. The MTO provides for assignment to the city traffic engineer of authority to do the following, in conformance with state manuals, specifications, and vehicle code (§ 32-302):

- a. Designate crosswalks, safety zones, stops, and stands for transit vehicles and taxis, freight and passenger loading zones;
- b. Determine and establish speed limits (in California, this must be done on basis of engineering and traffic investigation);
- c. Regulate the kinds and classes of traffic and the maximum size and weight of vehicles permitted on any street or portion of a street;
- d. Determine and designate lanes for the exclusive use of transit buses and high-occupancy vehicles, reverse-flow lanes, and commercial vehicle routes;
- e. Regulate the stopping, standing, or parking of vehicles, including the installation of parking meters on streets and in city-operated parking facilities;
- f. Determine and designate hazardous material routes subject to any law or regulation of the state or the U. S. Government.

Other duties, such as planning, geometric design, and reviews of plans, do not require specific legal authority.

- 3 **Traffic Commission.** The Model Traffic Ordinance also provides for the creation of a traffic commission (§32-101).

- a. *Membership:* traffic engineer, chief of police or designated representative, chairman of the traffic committee of the city council, representatives from the city engineer's and city attorney's offices, and other city officials or representative of unofficial bodies, such as a staff member of the automobile club.
- b. *Duties:* coordinate traffic activities, supervise preparation and publication of traffic reports, receive complaints, and make recommendations.

As an alternative, a traffic advisory committee can be established by administrative order.

## E. Administration of Traffic Engineering Departments

- 1 **Lines of Authority.** The organization of the department (e.g., as in Fig. 35-1), the lines of authority, and the manner in which responsibilities are delegated, must all be clearly set forth and understood.

- 2 **Public Relations** (see Ref. 5 for an excellent elaboration on this topic). Good public relations skills are essential. Always know what is going on, and share it with the public through the news media, neighborhood meetings, and other available channels of communication. For best working relationships with the media, prepare news releases and hold background briefings about any traffic engineering events that the public should or will want to know; be willing to be interviewed and know the answers.

Deal positively with all complaints: see that all oral complaints are taken down in writing; assign each one for investigation; give answers in writing; have a follow-up system to be sure that a reply is sent. Always reply, with reasons.

Public relations also involve good working relationships with other public officials, especially those for whom you are working. Be alert to the attitude of elected and senior appointed

officials with respect to your contacts with the media. It is often wise to let public officials make the initial announcement and even take the credit for a positive news item, such as the opening of a facility, receipt of a special grant, or a major reduction in accidents. In such cases, give the officials useful materials for media briefings.

Oral and written communications skills are described in Appendix B.

- 3 **Need for Records.** Complete and accurate records are a necessity:
  - a. To know what has been going on and to detect trends or changes in traffic behavior, accident patterns, etc.
  - b. To program and monitor maintenance.
  - c. To document conditions for legal purposes (e.g., liability court cases).
  - d. To answer complaints and inquiries.
- 4 **Kinds of Files.** Plans, diagrams, charts, and most correspondence can be filed in "hard copy" and in electronic form.
  - a. *Correspondence.* Complaints should be filed by location with cross-references by name of complainant. A master database to check on status of replies should be maintained.
  - b. *Work Orders.* Used to order work, and as a record for bringing up to date other records on status of control devices and time spent.
  - c. *Signs and Marking Inventories.* These records are geared to work order forms, and are also used to resolve legal issues.
  - d. *Signal Timing Charts and Time-Space Diagrams.* These are filed by location.
  - e. *Accident Records.* (See Chap. 9).
  - f. *Traffic Study Materials.* Filed by street location.
  - g. *Street Lighting Plans and Diagrams.*
  - h. *Geometric Designs.*
  - i. *Up-to-Date Maps.* These are for use as base maps for traffic control device inventories, accident analyses, truck, transit, and school bus route plotting.
  - j. *Follow-Up Files* to remind engineers of a later date to check on a problem.
- 5 **Coordination.** The traffic engineer must have continuing relationships with other government offices and interested groups. For example, it is important to send notices of changes in traffic controls to police, electrical, and street lighting engineers, the city or county clerk, auto clubs, transit companies, interested merchants, civic leaders, and neighborhood groups. Close coordination is also needed with utility companies that may be disturbing street pavements, including traffic markings, and with the government department that issues permits for such work. Finally, it is important to have regular contacts with the regional transportation planning agency and the state department of transportation.

#### REFERENCES

1. Institute of Transportation Engineers. *Urban Traffic Engineering Issues and Answers: Status and Effectiveness of Urban Traffic Engineering Agencies.* Final Report. Washington, DC: 1995, 46 p.
2. Institute of Transportation Engineers. *Urban Traffic Engineering Issues and Answers: Urban Traffic Engineering Education and Training Needs.* Final Report. Washington, DC: 1995, 56 p.
3. National Committee on Uniform Traffic Laws and Ordinances. *Uniform Vehicle Code and Model Traffic Ordinance.* Evanston, IL: 1992. And *Updates to the 1992 Uniform Vehicle Code.* 1998. And Revisions to UVC approved 1/11/00. 2000. Available at: [http://www.ncutlo.org/ami\\_info.html](http://www.ncutlo.org/ami_info.html).
4. League of California Cities. *Uniform Traffic Ordinance.* Berkeley and Los Angeles: 1964. 71 p.
5. Van Gelder, W. G. "Traffic Administration—Part A: Public Relations and Program Implementation Methods." *Traffic Engineering Handbook*, 4th Ed. Englewood Cliffs, NJ: Prentice-Hall, 1992, p. 419-425.



This appendix summarizes some common methods of statistical analysis used in traffic engineering. It is neither comprehensive nor pedagogic—it does not cover the entire spectrum of analysis tools, nor does it include the theoretical underpinnings and derivations found in the science of probability and statistics. Many textbooks on this subject are available and contain more extensive statistical tables than can be included here. Ref. 1 provides more detail on statistical applications related to traffic engineering data, and Refs. 2 and 3 cover statistical analyses involving traffic safety.

## A. Statistical Terminology

- 1 **Population:** The entire universe being studied; for example, all drivers in California, all drivers under 25 years of age in Los Angeles County, all under-25 drivers involved in alcohol-related accidents (whether reported or not) in Beverly Hills. Each of these examples is actually a subset or subpopulation of its predecessor; even the first one is a subpopulation of all inhabitants of California. However, each population contains all persons fitting the description.
- 2 **Sample:** That part of the population for which the analyst has data. Both intuition and statistical theorems support the concept that the larger the sample sizes, the more likely are they to properly reflect the characteristics of the population from which they were chosen. On the other hand, large samples may be impossible or prohibitively expensive to obtain; the trade-off between additional knowledge about the population and the marginal cost of additional data collection and processing underlies the determination of sample size.
- 3 **Degrees of Freedom:** Sample size is not the only concern in determining the quality of the information that can be derived from a data sample. In many statistical calculations the degree to which data are independent of each other, rather than being constrained by the values of other data, is important. "Degrees of freedom" describes the independence of data points: the number of degrees of freedom is defined as the number of observations or class frequencies whose values may be assigned arbitrarily.

In analyzing whether a coin being tossed a specified number of times is biased, the number of "heads" and "tails" are recorded; the number of heads might be any value, but the number of tails will be the difference between the total number of tosses and the number of heads; therefore there is only one degree of freedom. In analyzing whether there has been a bias over time in distributing a highway fund to ten counties, the nine allocations could be any value, but the tenth is fixed by the total funds available (nine degrees of freedom); but note that, if the law had required half the funds to go to five southern counties and half to five northern ones, then the amount remaining to be given to two counties (one in each group) would depend on other data, and there would be only eight degrees of freedom.

Degrees of freedom are also reduced when a previously calculated parameter, which is entirely fixed by the values used to calculate it, is used in an analysis. Thus, the calculation of the sample

mean of six independent values of travel time involves six degrees of freedom; however, the calculation of the sample standard deviation requires the use of the mean,\* which allows five data points to have arbitrary values with the sixth uniquely established to produce the mean's correct value. Therefore one degree of freedom is "lost," leaving five.

## B. Confidence and Significance

Engineers accustomed to using data to obtain "the correct solution" to a problem sometimes find it difficult to adjust to methods of analysis whose results have a probability of less than 1.0 (i.e., less than certainty) of being correct. Statistical methods do not prove anything; rather, the engineer formulates a hypothesis (e.g., the mean number of accidents is the same "before" and "after" a treatment) and then tests this hypothesis. There are risks, however, that the ultimate decision to accept or reject the hypothesis could be in error. Understanding the concepts of "confidence" and "significance" is essential to performing statistical analyses.

- 1 **Confidence:** The "additional knowledge about the population" mentioned in paragraph A.2. often relates to an assessment of how well the sample represents the population. The mean value ( $\bar{x}$ ) of a sample almost always differs from the true population mean value ( $\mu$ ); therefore, the analyst should describe a best estimate of the population mean as a number (e.g.,  $\bar{x}$ ) together with an interval where the true value lies with some specified confidence. The *amount of confidence* is expressed as a probability. To be "95% confident" means that there is a 95% probability that the true population mean lies within the specified interval.
- 2 **Significance:** The analyst may wish to know whether a subpopulation differs from its "parent," or whether two populations differ from each other. For example, is accident involvement of drivers under 25-year old really different from that of older drivers? Did it change appreciably after a special enforcement or publicity program? Samples from populations for which such comparison is to be made probably produce different values (e.g., means, proportions), but are these differences truly "significant"? Significance is defined in terms of the probability that the difference in sample parameters might have occurred by pure chance and that the populations are, in fact, *not* different. Thus, "significant at the 5% level" means that the observed differences could have come from samples of the same *population* only 5% of the time. The results of a test are *highly* significant if the differences are significant at a *low* level.

The data user must determine the levels of confidence and significance desired; high confidence and low significance levels usually come with large samples. The choice depends on how crucial a precise answer is. Traffic engineers often use a confidence level of 95% (there would be only one chance in 20 that the population value is beyond the interval indicated by the sample value). Similarly, the user selects the level of significance that is acceptable for the problem being studied; corresponding to the suggestion about confidence levels, traffic engineers might consider only results significant at the 5% level to be acceptable.

## C. Large Sample Studies

"Large" samples are defined as samples of such size that additional data points (increasing the sample size further) increase confidence rather slowly. "Small" samples, on the other hand, are those whose accuracy, as expressed by confidence limits, increases substantially with each additional observation. The dividing point is a sample of about 25 observations. Table A-1 demonstrates that t-values decrease slowly above 25 degrees of freedom.

An example of a large-sample study is the spot speed study; see Chap. 6, Sec. G., for a typical example and the method of analysis. The effect of larger samples in narrowing confidence intervals was demonstrated in Fig. 6-1. If the user wishes to determine the minimum sample size needed to obtain some selected level of accuracy (i.e., that size at which the standard error of the mean drops to a maximum acceptable value), the t distribution is used. The general form of this equation is:

\*The basic form from which Eq. [6.3] of Chap. 6 is derived is:

$$s^2 = \frac{\sum (x_i - \bar{x})^2}{n - 1}$$

$$t = \frac{\bar{x} - \mu}{s / \sqrt{n}} \tag{A.1}$$

Setting  $(\bar{x} - \mu) = \epsilon$  and transposing the result yields (as in Eq. [7.3]):

$$\epsilon = t_{\alpha} \cdot \frac{s}{\sqrt{n}} \tag{A.2}$$

- where:  $\bar{x}$  = sample mean,
- $\mu$  = mean for the population,
- $\epsilon$  = error of the mean at chosen confidence level,
- $s$  = standard deviation of the sample,
- $t_{\alpha}$  =  $(1 - \alpha)$ th percentile of the t distribution with  $(n - 1)$  degrees of freedom,
- $\alpha = \frac{\text{percent of confidence level chosen}}{100}$
- $n$  = sample size.

Note that is  $\frac{s}{\sqrt{n}}$  the standard error of the mean (compare Eq. [6.4]).

In "large" samples, the values of  $t_{\alpha}$  for any value of  $n$  approach those listed in Table A-1 on the line showing  $\infty$  degrees of freedom. Therefore, with a given value of  $\epsilon$  and a first estimate of the value of  $s$  (to be confirmed from field data later), Eq. [A-2] can be solved for  $n$ .

**Table A-1—Values of the "t" Distribution**

Degrees of Freedom	Values of $\alpha$			Degrees of Freedom	Values of $\alpha$		
	0.05	0.02	0.01		0.05	0.02	0.01
1	12.706	31.821	63.657	16	2.120	2.583	2.921
2	4.303	6.965	9.925	17	2.110	2.567	2.898
3	3.182	4.541	5.841	18	2.101	2.552	2.878
4	2.776	3.747	4.604	19	2.093	2.539	2.861
5	2.571	3.365	4.032	20	2.086	2.528	2.845
6	2.447	3.143	3.707	21	2.080	2.518	2.831
7	2.365	2.998	3.499	22	2.074	2.508	2.819
8	2.306	2.896	3.355	23	2.069	2.500	2.807
9	2.262	2.821	3.250	24	2.064	2.492	2.797
10	2.228	2.764	3.169	25	2.060	2.485	2.787
11	2.201	2.718	3.106	30	2.042	2.457	2.750
12	2.179	2.681	3.055	40	2.021	2.423	2.704
13	2.160	2.650	3.012	60	2.000	2.390	2.660
14	2.145	2.624	2.977	120	1.980	2.358	2.617
15	2.131	2.602	2.947	$\infty$	1.960	2.326	2.576

### D. Small Sample Studies

Where data collection is expensive, "small" samples ( $n < 25$ ) must be accepted. For example, in a travel time study using the average car method, a round-trip set of observations may require one person-hour plus vehicle operating costs. The problem might be stated as follows:



How large of a sample is required to be 95% confident that the sample mean value  $\bar{x}$  will be within  $\pm 10\%$  of the population mean, assuming that the mean travel time is  $\bar{x}$  and the standard deviation of the travel time distribution is about 15% of  $\bar{x}$ ?

The value of  $t_\alpha$  is not constant in this case, because of the small degrees of freedom. Eq. [A-2] must therefore be solved by trial and error. For example, if  $\bar{x} = 30$  min (hence,  $s = 4.5$  min and  $\epsilon \leq 3.0$  min), and given that  $\alpha = 0.05$ :

$n$ (Trial)	Degrees of Freedom	Value of $t_\alpha$	Calculated $\epsilon$	Result
6	5	2.571	4.72	$\epsilon$ too high
8	7	2.365	3.76	Still too high
10	9	2.262	3.22	Still too high
12	11	2.201	2.86	OK (<10% of $\bar{x}$ )

Twelve runs should therefore be requested. Before completing the study, however, the standard deviation of the mean travel times must be calculated; if it is greater than the estimated 4.5 minutes, then recalculate  $\epsilon$ ; if this is now more than 3.0 minutes, the sample size may have to be increased.

### E. Differences of Means of Small Samples

Calculating the significance of differences of small samples uses the same t distribution as when large samples are involved (Eq. [A-1]). When the difference of two means is tested, the formula becomes:

$$t = \frac{(\bar{x}_1 - \bar{x}_2)}{s} \sqrt{\left(\frac{n_1 n_2}{n_1 + n_2}\right)} \tag{A.3}$$

where the term under the square root sign is the reciprocal of the sum of the reciprocals of the two sample sizes. The value of the combined standard deviation is:

$$s = \sqrt{\frac{\Sigma(x_1 - \bar{x}_1)^2 + \Sigma(x_2 - \bar{x}_2)^2}{n_1 + n_2 - 2}} \tag{A.4}$$

Because the mean of each of the two samples being compared has already been calculated, two degrees of freedom have been "lost" (note the denominator of the right side of Eq. [A-4]).

For example:

At various times during 1996, a city implemented intersection sight distance improvements at 10 two-way STOP-controlled intersections. The "before" and "after" accident experience at these locations is summarized in the following table.

Before		After	
1993	32	1997	27
1994	41	1998	19
1995	36	1999	30
$\bar{x}_1 =$	36.33	$\bar{x}_2 =$	25.33

The hypothesis is that the "after" sample comes from the same population as the "before" sample; in other words, there is no change between the two periods. Referring to Table A-1 for 4 degrees of freedom,  $t$  must exceed 2.776 for the reduction in accidents to be significant at the 5% level. Because the calculated  $t$  is less than this value, the hypothesis that "before" and "after" accident experience is the same cannot be rejected. This conclusion might change as more data from the "after" period become available.

## F. Studies Involving Proportions (Use of Binomial Distribution)

Some studies deal with counting Yes-No situations. Although coin-tossing is frequently used as an illustration, a traffic engineering example is given here. In such situations, the proportions of "Yes" and "No" are given. Again, it is both instinctive and statistically provable that the accuracy of the result derived from a set of observations increases with the sample size.

Provided that the probability of events occurring or not occurring is not close to zero, the normal approximation to the *binomial distribution* can be used to analyze the data.\* For a sample of  $n$  observations, with  $p$  the proportion of "Yes" results and  $q$  the proportion of "No" results ( $p + q = 1.0$ ), the standard error of the mean is  $\sqrt{(pq/n)}$ , and the maximum likely error is again the standard error of the mean multiplied by the appropriate value from the  $t$  distribution:

$$\epsilon = t_{\alpha} \cdot \sqrt{\frac{pq}{n}} \quad [\text{A.5}]$$

For example:

In a "before" study, 185 out of 648 vehicles (a proportion of 0.285) were found to be parking overtime. After a change in enforcement procedures, 119 of 512 vehicles (a proportion of 0.232) were parking overtime. Were the sample sizes adequate (what are the 95% confidence limits of the value of  $p$ ) and was the change significant?

The first question is answered by the following calculation:

Sample	$n$	$p$	$q$	$t_{\alpha}$	$\epsilon$	$\frac{\epsilon}{p} \cdot 100$
Before	648	.285	.715	1.96	.0348	12.2
After	512	.232	.768	1.96	.0366	15.8

In the before sample, the analyst is 95% confident that the true proportion of offenders is within  $\pm 0.0348$ , or  $\pm 12.2\%$ , of the mean value; in the after sample, the corresponding values are  $\pm 0.0366$  and  $\pm 15.8\%$ .

The  $t$ -statistic from the following formula is used for the significance of difference test:

$$t = \frac{p_1 - p_2}{\sqrt{p_0 q_0 \left( \frac{1}{n_1} + \frac{1}{n_2} \right)}} \quad [\text{A.6}]$$

where:  $p_0 = \frac{p_1 n_1 + p_2 n_2}{n_1 + n_2}$

$$q_0 = 1 - p_0$$

and subscripts 1 and 2 refer to the "before" and "after" samples, respectively.

Then  $t = 2.04$ . From Table A-1, for  $\infty$  degrees of freedom, this value of  $t$  falls between the values when  $\alpha = 0.05$  and when  $\alpha = 0.01$ . Therefore, the difference is significant at the 5% level but not at the 1% level.

---

\* For analysis of "rare events" with low probabilities of occurring, see Section H. below.

### G. The Chi-Square Test of Goodness of Fit and of Significance

The chi-square ( $\chi^2$ ) test compares observations with those expected from some known or suspected hypothesis. It can test both the hypothesis that the observed values *do* come from an assumed distribution of values (goodness of fit) and that they do not (significance of difference). The basic form of the  $\chi^2$  distribution is:

$$\chi^2 = \sum \left( \frac{(O - E)^2}{E} \right) \tag{A.7}$$

where: *O* = the observed frequency in each class

*E* = the corresponding expected frequency for the hypothesized distribution

- The goodness of fit test may be applied to the speed data in Table 6.1 to determine if the distribution is normal, as is often assumed, or if it is skewed by the presence of trucks or a substantial number of out-of-state motorists. Expected frequency values (*E*) for a normal curve are obtained from a standard statistical handbook;  $\chi^2$  is then computed to determine if the speed data are likely to have come from a normal distribution with  $\bar{x} = 48.14$  km/h and  $s = 5.31$  km/h. A common rule for applying this test is that the expected frequency for each class should exceed 5; to meet this requirement, adjacent classes near each tail of the distribution must be combined. The results are summarized below:

Speed (km/h)	Frequency			$\frac{(O - E)^2}{E}$
	Observed ( <i>O</i> )	Expected ( <i>E</i> )		
≤35	0	0.95	} 5.69	3.271
36	2	0.61		
37	1	0.91		
38	3	1.34		
39	4	1.88		
40	1	2.55	} 10.14	0.973
41	3	3.33		
42	3	4.26		
43	2	5.19		
44	7	6.08		
45	6	6.95		0.130
46	5	7.60		0.890
47	7	8.09		0.146
48	9	8.28		0.062
49	12	8.13		1.843
50	10	7.79		0.628
51	6	7.13		0.179
52	8	6.35		0.431
53	4	5.42		0.373
54	6	4.50	} 10.85	0.123
55	4	3.60		
56	2	2.75		
57	1	2.06		
58	2	1.47		
59	1	1.01	} 6.31	0.273
60	0	0.69		
61	0	0.43		
62	1	0.28		
≤63	0	0.37		

$$\chi^2 = \sum \left( \frac{(O - E)^2}{E} \right) \tag{A.7}$$

11.42

The value of  $\chi^2$  for 12 degrees of freedom (three degrees of freedom are lost because the sample's  $n$ ,  $\bar{x}$ , and  $s$  were used to calculate the expected frequency) and for  $\alpha = 0.05$  is 21.03 (Table A.2). Because the calculated value of  $\chi^2$  (11.42) is less than the tabular value, the hypothesis that the data are normally distributed is accepted.

2 The following example uses the  $\chi^2$  distribution to test the significance of a difference: Is the reduction of accidents at a recently improved intersection significant? Because a preliminary answer is required within a year after the improvement, a trend analysis (as in Sec. F.) cannot be used. It is therefore decided to compare the performance of the intersection (the "test") to all similar intersections in the city (the "control"). The following table gives both data and algebraic symbols used in Eq. [A-8]:

	Before		After		Totals	
Test	$a$	20	$b$	15	$(a+b)$	35
Control	$c$	4321	$d$	4314	$(c+d)$	8635
Totals	$(a+c)$	4341	$(b+d)$	4329	$n$	8670

Accidents at the intersection went down 25 percent, while citywide accidents remained about the same. But is this a significant accident drop? It can be shown that Eq. [A-7] can be written as:

$$\chi^2 = \frac{n(ad - bc)^2}{(a + b)(c + d)(a + c)(b + d)} \tag{A.8}$$

In this example,  $\chi^2 = 0.722$ . There is one degree of freedom, because only one of the input data items  $a$ ,  $b$ ,  $c$ , or  $d$  can be assigned an arbitrary value; all others must follow from the row and column totals. In Table A-2,  $\chi^2 = 3.84$  ( $\alpha = 0.05$ ); this is greater than the calculated value, and the hypothesis that the test site data come from the same population as the control sites cannot be rejected. Therefore, the conclusion is that the intersection improvements may not have caused a reduction in accidents. (Hint: If the value of  $\chi^2$  is less than the number of the degrees of freedom, differences are never significant and there is no need to go to a table.)

**Table A-2—Selected Values of the  $\chi^2$  Distribution**

Degrees of Freedom	Values of $\alpha$				Degrees of Freedom	Values of $\alpha$			
	0.10	0.05	0.02	0.01		0.10	0.05	0.02	0.01
1	2.71	3.84	5.41	6.63	16	23.54	26.30	29.63	32.00
2	4.61	5.99	7.82	9.21	17	24.77	27.59	31.00	33.41
3	6.25	7.81	9.84	11.34	18	25.99	28.87	32.35	34.81
4	7.78	9.49	11.67	13.28	19	27.20	30.14	33.69	36.19
5	9.24	11.07	13.39	15.09	20	28.41	31.41	35.02	37.57
6	10.65	12.59	15.03	16.81	21	29.62	32.67	36.34	38.93
7	12.02	14.07	16.62	18.48	22	30.81	33.92	37.66	40.29
8	13.36	15.51	18.17	20.09	23	32.01	35.17	38.97	41.64
9	14.68	16.92	19.68	21.67	24	33.20	36.42	40.27	42.98
10	15.99	18.31	21.16	23.21	25	34.38	37.65	41.57	44.31
11	17.28	19.68	22.62	24.73	26	35.56	38.88	42.86	45.64
12	18.55	21.03	24.05	26.22	27	36.74	40.11	44.14	46.96
13	19.81	22.36	25.47	27.69	28	37.92	41.34	45.42	48.28
14	21.06	23.69	26.87	29.14	29	39.09	42.56	46.69	49.59
15	22.31	25.00	28.26	30.58	30	40.26	43.77	47.96	50.89

### H. Analysis of "Rare Events"-The Poisson Distribution

If the probability of events occurring or not occurring is very small, the Poisson distribution can be used. One example is the number of accidents, which are rare events when compared to the opportunities for collision as reflected by vehicle-km of travel on the highway. The distribution is also used to calculate probabilities of certain events happening, e.g., that no more than 5 trucks will pass a point within a 3-minute period. The Poisson distribution is used to test for significant differences in data involving rare events and for certain traffic flow analyses.

Poisson-distributed probabilities are given by the series:

$$e^{-m} \left( 1, m, \frac{m^2}{2!}, \frac{m^3}{3!}, \dots, \frac{m^i}{i!}, \dots \right) \tag{A.9}$$

The first term represents the probability of no event occurring, the next one that one event will occur, and so forth. The total of the series within the parentheses is  $e^m$ , thus the total of all probabilities is unity;  $m$  is both the mean and the variance of the distribution.

- 1 *Use of the Poisson Distribution to Test Significance of Differences.* The Poisson distribution is used to test whether a single result differs significantly from the mean of other results, where that mean is known to a high degree of confidence. The following example illustrates this:

In the example from Sec. G., assume that the average number of accidents per year at the intersection under study had been 20 for many years before improvement. If there is a small probability that the "after" experience of 15 accidents could have come from the same (Poisson) distribution, then the difference may be said to have been significant. Summing the first 16 terms of Equation [A-9] with  $m = 20$  (or, more likely, looking up the result in a statistical handbook), the probability that 15 or fewer accidents might occur is 0.156; i.e., there is a probability of more than 15% that the "after" accident experience might have happened without any improvement.

Figure A-1 combines the  $\chi^2$  and Poisson analyses for changes in accidents, where only one period of data for the "after" experience is known. Note that these curves are plotted for testing whether the percent reduction in accidents is significant at the 5% level. Points falling below a curve do not meet this significance test. The two curves represent different situations:

- a. As stated above, the Poisson test compares the data from one "after" period with the mean of many "before" periods, a mean which has a small standard error. This test is considered "liberal" in that it minimizes the probability of judging a change as nonsignificant when in fact it is significant. Entering the graph of Figure A-1 for 20 "before" accidents, note that a 25% improvement falls below the Poisson curve and is therefore not significant at the 5% level.
- b. The  $\chi^2$  test compares one "before" and one "after" period of data. It is considered "conservative" because it reduces the probability that a change is labeled significant when it is not.

Where "before" data are limited, the  $\chi^2$  curve must be used. Neither one of these technique accounts for regression to the mean.

- 2 *Use of the Poisson Distribution to Analyze Traffic Phenomena.* This same distribution can be used to calculate the probability of such traffic situations as:
  - a. A queue being longer than  $n$  vehicles, thereby perhaps exceeding the length of a left-turn lane or blocking an upstream intersection;
  - b. More than  $n$  cars breaking down in a 10-minute period, thereby indicating the number of service vehicles that should be available for freeway or toll bridge service;
  - c. The number of gaps in a traffic stream  $\leq n$  seconds, through which crossing or left-turning traffic can proceed.

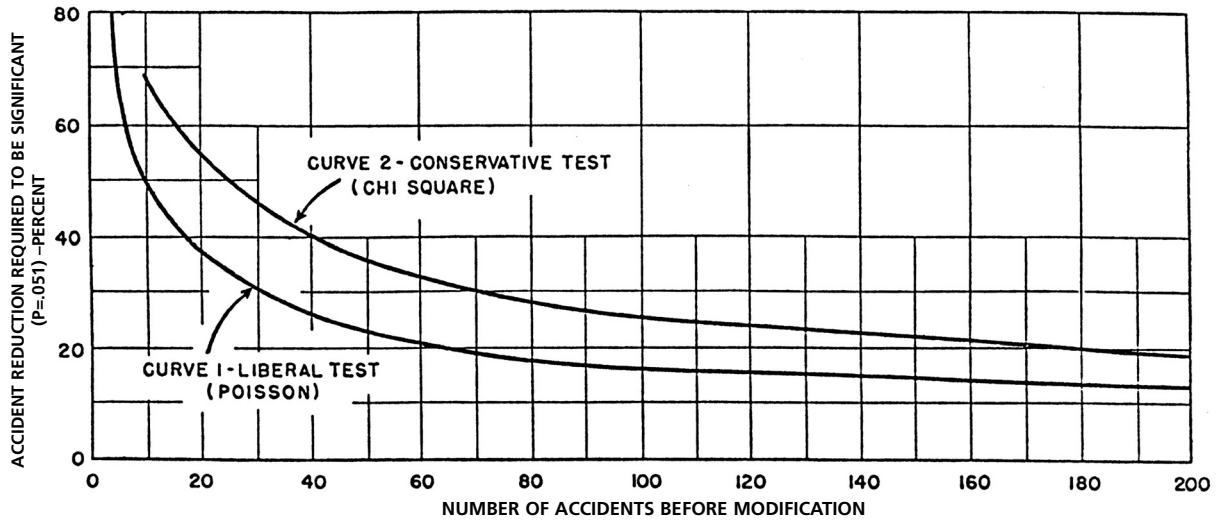

**Fig. A-1—Poisson and  $\chi^2$  Curves for Determining the Statistical Significance of Accident Reduction at the 0.05 Level**

REFERENCES

1. Robertson, H.D., et al. *Manual of Transportation Engineering Studies*. Englewood Cliffs, NJ: Prentice-Hall, 1994.
2. Council, F.M., et al. *Accident Research Manual*. U.S. Federal Highway Administration. FHWA-RD-80-016. 1980.
3. Hauer, E. *Observational Before-After Studies in Road Safety*. Tarrytown, NY: Pergamon, 1997.



## A. Introduction

It is just as important for engineers to communicate in prose as it is for them to inform the driving public with signs, signals, and pavement markings. Several recent surveys have found that engineers spend one-half to two-thirds of their time involved in some form of written or oral communication. Poor communication can result in misunderstandings, improper actions, loss of public or professional support, and legal liability.

Good technical writing (and by extension, the content of an oral presentation) has ten essential characteristics (Ref. 1). It is

- 1 **Technically Accurate.** Inaccurate statements tell readers that you were careless or lazy; they can destroy your credibility.
- 2 **Useful.** Don't waste readers' time by including unnecessary information, even if you think it is interesting or entertaining.
- 3 **Concise.** Mathematician and physicist Blaise Pascal once wrote to a friend, "I have made this a long letter because I haven't the time to make it shorter." Organizing your thoughts and choosing the most effective words take time, but they are essential tasks.
- 4 **Complete.** Careful writing includes defining terms as needed, conveying factual information, and presenting enough analysis to make the information useful to the reader.
- 5 **Clear.** The document must convey a single message that the reader can readily understand. In order to clearly convey this message, the writer must first decide or understand what it is.
- 6 **Consistent.** Consistency is important not only for the information presented, but also for the manner of presentation. An alarming number of technical reports contain apparently random use of basic elements such as capitalization, punctuation, and abbreviations. As Ref. 1 notes, "The trouble with being inconsistent is that you are automatically wrong at least some of the time."
- 7 **Correct in Spelling, Punctuation, and Grammar.** Grammar and punctuation errors suggest to the reader that whoever wrote the document is either sloppy or uneducated; this, in turn, leads the reader to wonder about the correctness of the technical content of the document.
- 8 **Targeted.** Before beginning to write, the writer should assess the technical competence and information needs of the intended readers.
- 9 **Well Organized.** A logical structure leads readers through the material. Structural devices such as subsection titles and bulleted lists are also helpful.
- 10 **Interesting.** If the document is boring, readers will stop reading or their attention will wander.



## B. Types of Documents

Most of the documents engineers write fall into the broad categories of reports (long or short), correspondence (letters, memos, faxes, and e-mail), journal articles, and specialized documents (e.g., public announcements, specifications, and manuals). Organizations commonly expect their employees to follow format and structure guidelines for various document types. If your employer or publisher does not give you specific guidelines, check technical writing manuals such as Refs. 1, 2, and 3.

1 **Reports.** Formal reports should be written in the third person (i.e., sentence subjects are either nouns or pronouns like "he," "she," and "they"). Informal reports can be written in the first (using pronouns like "I" and "me") or second person (using "you"). In either case, keep in mind the general guidelines in Sec. A, above.

2 **Traditional Correspondence.** Improve your letters and memos by following these tips:

a. *Use natural language.* Avoid clichés and awkward, overly formal, or "impressive" language. Technical writing manuals offer many examples such as these:

<i>Rather than:</i>	<i>Use:</i>
Enclosed please find	Enclosed is
I am forwarding herewith	I'm sending
Awaiting your earliest reply, we remain	Sincerely
Per your inquiry of	In response to your question
Please don't hesitate to call	Please call me
As per our conversation	As we discussed
The undersigned	I
Above referenced	(delete)

b. Use positive language. Never write a letter or memo while you are angry; talk to someone about the situation so you can vent your anger, and then write a calm response. Use a neutral or positive tone; for example, "your letter stated that the necessary supplies were unavailable" is less provocative than "you claimed that the necessary supplies were unavailable."

c. Keep the reader's needs and feelings in mind. Try to look at a situation as your reader would, and phrase things to address his or her point of view. For example, "the new report guidelines will save you time" is better than "I am sending you new report guidelines."

3 **Electronic Correspondence.** E-mail and fax communication save time, but they present some problems.

a. They are not private. Fax messages can be read by anyone who walks by the machine. E-mail is often forwarded to people who may not understand brief references or inside jokes.

b. They are too quick and easy. Senders often don't think about them as carefully as they would when composing a letter or memo. Or they may respond to an unpleasant message before taking time to cool off.

c. They tempt writers to forget about proper etiquette.

(1) Don't forward e-mail to third parties unless you are sure they want or need it.

(2) If a series of e-mail messages has turned into an emotional battle, switch to the telephone or a face-to-face conversation so you can use things like a calm voice or facial expressions to ease tensions.

(3) Never change a message from another person and then forward it to someone else so that it appears the original author wrote something he or she didn't.

(4) Use the recipient's name in the message and sign it with yours. Clearly specify details like times and dates; the recipient may not read the message the same day you send it.

(5) Use good grammar and form so your message conveys competence and professionalism. Don't type your message in all capital or all lower-case letters; such messages are hard to read, and they create the impression of shouting or lack of confidence, respectively.

- 4 **Specialized Documents.** Fliers and newspaper announcements for public meetings require careful preparation to meet the readers' needs and to present a positive, professional image of the organizers. Uncluttered, well-labeled maps and a nontechnical tone are helpful. Ref. 1 presents specific guidelines for preparing manuals and specifications.

## C. Planning a Document

Building a road involves more than sending out the paving crew, and writing involves more than putting words on paper. Time spent on creating a document should be allocated roughly as follows:

Planning	20%
Organizing	20%
Writing	30%
Editing and Rewriting	30%

The planning phase consists of four basic steps:

- 1 **Analyze the reader.** Decide what information the reader(s) needs to get from the document. Assess the reader's knowledge base and level of technical proficiency.
- 2 **Analyze your purpose.** Don't let yourself get by with thinking you want to "write about" a project or a problem. Figure out why you are writing about it. For example, is it to convince someone, create a record, request action or funding, or answer a request for information? If you don't figure out what you want to accomplish, you probably won't accomplish it.
- 3 **Analyze the context.** Is there any hostility involved, either on the part of the reader, your organization, or yourself? What format guidelines, governmental requirements, or professional standards must be followed?
- 4 **Gather information.** Make sure it is accurate, relevant, and up to date. If possible, verify information by checking additional sources.

## D. The Technical Content

Having the best information available is not enough—it must also be applied correctly and presented accurately. Engineers tend to feel comfortable with the technical content of their documents; consequently, they proofread that material less diligently and overlook errors.

- 1 **Common technical errors.** Ref. 4 lists the most common types of technical inaccuracies, including the following:
  - a. *miscount* (e.g., writing "the four people: Smith, Jones, and Davis")
  - b. *conversion* (e.g., using the wrong conversion factor)
  - c. *arithmetic* (unit or number) (e.g., typing the wrong number or writing a habitual English unit rather than the correct metric one)
  - d. *precision* (e.g., calculating a value to a greater degree of precision than the data justify)
  - e. *numeric inconsistency* (e.g., "the first study was done in 2001" on one page, and "we have been studying this for the past two years" on another page of a 2005 report)
  - f. *misrepresentation of data or bad data* (e.g., "most of the accidents resulted from driver inattention" when 26 out of 50 did, or listing categories by percentages that don't add up to 100)
  - g. *cross-reference to wrong or nonexistent location* (e.g., "See the site map on page 5 of this report" when the map is actually on page 6)

- h. *numeric or alphabetic sequences* (skipping or repeating a number or letter in the sequence)
  - i. *inconsistent information* (e.g., "we base our design on stopping sight distance" on one page and "because the passing sight distance was inadequate, we revised the design" on another)
  - j. *factual error*. (One report included a statement about studying a New Mexico route "northward from the Arizona border" when the writer meant the Texas border. For other reasons, this document was entered into evidence in a legal proceeding. Anyone reading the document might wonder what other careless errors the writer made.)
- 2 **Other barriers to credibility.** In an *ITE Journal* article, the ITE Coordinating Council warned: "If we, the trained and experienced professionals, lack credibility, decision-makers may follow their own wisdom or the direction of the most vocal interest groups. Such decisions may not be in the best interests of the constituency's mobility and safety." Ref. 5 goes on to describe the most common destroyers of credibility. For example, be sure you know what you are talking about, and don't pad the truth; any inconsistencies between your assumptions and observable facts are deadly. If an analyst on the opposing side of an issue reaches a different conclusion, be prepared to justify your assumptions and analysis.

Readers will doubt the credibility of a document that is not logically organized, contains grammatical errors, or appears sloppy. In addition, certain choices of wording may raise doubts about the accuracy or reliability of the information in the document. For example:

- a. Using the word "feel" undermines the apparent professionalism of your results. Engineering is based on facts and analysis, not feelings. Instead, use wording like "I am convinced" or "the analysis has shown."
- b. Inflated wording is another writing flaw that undermines credibility. Besides being hard to read, it can create the impression that the writer is trying to make something sound better than it is or cover up a real or perceived inadequacy. Here are some examples: (Ref. 6)
  - (1) "The background information has been surveyed and organizational activities preparatory to initiation of the two component phases of the project being contemplated at this time have been instituted." *Translation*: "After a search of the literature, we have decided to attack the problem in two steps."
  - (2) "Equipment in this category is especially advantageous in that it is easily adaptable for nontechnical personnel in field operations." *Translation*: "Untrained field workers will find this equipment easy to use."

## E. Organizing the Information

To be effective, a document must be structurally sound. A document showing a clear, logical presentation of information is much more useful than one containing a random assortment of information and ideas. This means you must outline before you write. Do it any way you wish; no one will see your outline—but everyone will notice if you don't make one. If you modify your outline while you are writing, keep an eye on the overall picture to make sure the change doesn't weaken the total document.

## F. Structuring the Document

"Research has demonstrated that comprehension and retention are controlled to a significant extent by the physical appearance of a document.... The layout of a report can make it dull, dense-looking, and hard on the eyes; or it can render a discussion with high technical density visually inviting, easy to absorb, and hard to forget." (Ref. 6)

### 1 Basic design elements

- a. *White space*. A page packed full of text is difficult to read. Here are four ways to make it less intimidating:

- (1) Avoid narrow margins. Leave at least one inch on each edge of the page.
  - (2) Consider carefully whether you are going to use a ragged right margin. "Full justification" (like the format of this book) is easy with computers, and many writers think it makes their document look more professional. However, the subtle changes in spacing between letters can make fully justified text more tiring to read. Here are some issues to consider when making the justification decision:
    - *readability*. Although some studies have found little difference in readability between ragged right and fully justified text, one found that 70% of readers considered ragged right text easier to read. (Ref. 3)
    - *desired image*. Fully justified text appears more formal.
    - *hyphenation problems*. When using fully justified text, minimize excessive word spacing by using your word processor's automatic hyphenation option. But watch for problems like badly hyphenated words (e.g., therapist printed as the-rapist) and several consecutive lines that end with hyphens.
  - (3) Avoid lengthy paragraphs. If you have written a paragraph that is half a page long, see if you can separate it into two shorter ones or edit it to be more concise.
  - (4) Use bulleted or enumerated lists. (See below.)
- b. *Informative headings*. Besides introducing white space, informative headings guide the reader to specific types of information.
  - c. *Headers and footers*. Include page numbers, document title or file reference, and date.
  - d. *Typographic devices*. Because of their availability, there is a temptation to use too many of these devices or use exotic variations that detract from the document's appearance rather than improving it. However, the following devices are common:
    - (1) *font and size*. Use something fairly common, in a size that is easy to read. Stick with one font throughout your document.
    - (2) *italics*. This is more attractive than underlining words. Avoid using it for emphasis; it is better to choose your words so the emphasis comes from them. Use italics for
      - titles of books and periodicals (e.g., "*The AASHTO Policy on Geometric Design of Highways and Streets* recommends the following lane widths....")
      - to set off words and phrases when they are discussed as words (e.g., "the word warrant means....")
    - (3) **boldface**. Bold print helps emphasize headings. It can also be used effectively to highlight an important warning statement in the text.
- 2 **Lists**. The simplest form of list is a sentence containing a sequence of three or more items, which are separated by commas. If one or more of the listed items contain commas, separate the items with semicolons (e.g., "Speed studies were conducted at this location on July 1, 2000; August 8, 2002; and September 3, 2004.").

If the list is long, or if the individual elements of the list are lengthy or complex, it may be clearer to format the list vertically. The rules for introductory punctuation are rather obscure, so the safest rule of thumb is this: Introduce the list with a complete sentence followed by a colon. [Don't write "These are:" although you could write "These are the following:"]

Format your list with these guidelines in mind:

- a. *punctuation*. It is not necessary to put any punctuation after each item in the list unless each item consists of one or more complete sentences.
- b. *format*. The list may be delineated with bullets, numbers, or letters. Use spacing and indentation that make the list easy to read.
- c. *parallelism*. The items in a list should all have the same grammatical construction. In other words, they should all be either complete sentences or fragments. Every item should begin with the same part of speech, in the same form (e.g., "write, read, and listen" or "writing, reading, and listening").

- 3 **Graphics.** In technical documents and presentations, graphics are used to convey information, not merely to make the document attractive or give the audience something to look at other than the speaker. They must be designed to deliver the desired information clearly and conveniently.
- a. *General tips*
    - (1) Make the graphic relevant to the text, but don't assume the relevance is obvious. In the text, tell the reader what to see in the illustration.
    - (2) Make the graphic as simple and uncluttered as possible.
    - (3) Give each graphic a caption (title) and a figure number. Figure titles are usually placed below the graphic.
    - (4) If you have to turn a graphic sideways to make it fit on a page, print the caption with the same orientation as the graphic, but keep headers and footers (including page numbers) in the same orientation as the body of the document. Insert the page in your document so that the top of the illustration is on the left.
  - b. *Specific tips.* Chap. 4 of Ref. 3 gives helpful guidelines for creating good drawings, maps, flowcharts, line graphs, pie charts, and bar charts.
- 4 **Tables.** Organizing information into tables can make it easier to read and easier to compare. See Chap. 4 of Ref. 3 for useful guidelines.

## G. The Writing Process

"For whatever reason, writing apparently does not come easily to a great many engineers, but then it comes easily to few writers, either. It is hard work, and problems in writing can be at least as difficult to solve in words as problems in engineering can be in equations." (Ref. 7)

- 1 **Effective writing.** (For a more detailed discussion, see Ref. 1.)
  - a. *Use the active voice.* In an active-voice sentence, the subject acts (Smith wrote the report), whereas in a passive-voice sentence, the subject is passively acted upon (the report was written). Although the passive voice is sometimes the best choice, it is often used as an evasion of responsibility, either for actions or for statements in the document.
  - b. *Delete words, sentences, and phrases that do not add to your meaning.* A writer who is having trouble explaining something may try to solve the problem by pouring on more words; it takes more mental effort to stop and figure out how to explain the topic concisely. For example, rather than writing "the construction of new structures at the low-water crossings will provide a facility that improves the overall safety and level of service," write "building new structures at the low-water crossings will improve the overall safety and level of service."
  - c. *Use specific and concrete terms rather than vague generalities.* Improper use of *etc.* is a common way of introducing vague generalities. The word *etc.* (literally, "and other things") should be used only when the reader can predict its meaning. For example, consider the statement "Several features such as safety barriers, noise walls, etc., will be constructed in the project for public safety and benefit." It is unclear what other features will be constructed. The phrase "such as" implies that only a few selected examples will be given; therefore, it is unnecessary to add "etc."
  - d. *Keep ideas and sentence structure parallel.* Lack of parallelism makes the following sentence confusing: "The proposal for the work must contain the complete design, provision for traffic control, show all new slope limits, and contain complete cost information." A better version is "The proposal for the work must contain the complete design, describe provisions for traffic control, show all new slope limits, and include complete cost information."
  - e. *Use an informal rather than a formal style.* For example, rather than writing "enclosed herewith you will find the final report on the subject project," write "I have enclosed the final report on this project."

- 2 **Common writing mistakes.** Some mistakes involve an inadequate knowledge of the rules of grammar, punctuation, or capitalization. Consult a writing manual; Ref. 2 is free, and many dictionaries contain summaries of the basic rules of writing. Other mistakes are introduced during revisions. Moving, deleting, or adding words can result in errors like sentence fragments, extra words, and disagreement of number between the verb and its subject or object.
- 3 **Word processing woes.** Use your word processor's spell-check feature. But don't rely on it blindly; it will not catch some types of mistakes. For example, it won't think you made an error if you typed "medium" for "median", "steal" for "steel", "off ice" for "office", or "wave" for "waive".
- 4 **Proofreading.** Proofread a document twice—once for logical coherence and technical content, and once for mechanics such as punctuation, capitalization, grammar, and sentence fragments. Print out a copy of your document and proofread it; you will find errors you didn't notice on the computer screen. You are so familiar with what you wanted to say that you may read what you meant rather than what you wrote; ask a colleague to proofread your document, and return the favor.

## H. Unintended Consequences

The Law of Unintended Consequences states that whatever we do, something unforeseen will result. The unanticipated result(s) may be either positive or negative. The negative ones are what writers must watch out for. Remember that each document you write may be read by people other than the ones you intended it for, including an attorney who is involved in a lawsuit against you or your employer.

When reviewing a document you have written, ask yourself the following questions: (Ref. 3)

- 1 *Are your facts accurate, and do your graphics present data without distortion or bias?*
- 2 *Have you differentiated clearly between fact and opinion?* Good engineering judgment doesn't occur simply because the author is a professional engineer; consider your technical decisions carefully, and word your documents in a way that makes it clear that you have done so.
- 3 *Have you checked for unwise or potentially misleading word choices?* For example, even if 90% of the local population affectionately refers to a certain location as "Dead Man's Curve," don't do so in your communications.
- 4 *Are your research sources reliable and appropriate for an unbiased presentation of data?* Whenever you make (or imply) a factual statement, be sure you can back it up with valid documentation; don't rely on "common knowledge" or "conventional wisdom." For instance, if you write that "On the Interstate, large trucks travel at higher speeds than passenger cars," have data available in case someone challenges the truth of your statement. In fact, as you check the facts before writing them, you may find that there are important limits of applicability that you must mention, or that the "fact" is actually somewhat different than you had thought.
- 5 *Is your information presented in a context that helps readers understand the implications of the facts?*
- 6 *Have you included any potentially libelous statements or misrepresentations that could cause your firm or agency to lose its reputation or that could result in lawsuits?*

## I. Public Speaking

- 1 **Public relations.** William van Gelder's article, "Public Relations and Program Implementation Methods," in Chap. 14 of Ref. 8 includes the following principles of public contact:
  - a. *Understand the other person's point of view.* Don't react personally to the person's remarks, even if they take the form of personal attacks.
  - b. *Let the person tell his story.* "The best medicine for angry citizens is to let them get things off their chests, *without getting you upset!*... You can count on some people not listening to you until they tell their story anyway."

- c. *Learn to listen.* "Don't give a solution until a clear-cut, mutually understood problem definition is agreed to."
  - d. *Speak their language.* Anticipate the technical knowledge of your audience, and explain technical terms appropriately.
  - e. *Say it with respect.* "Courtesy, respect, and consideration are all shown in little ways: a friendly tone of voice (but not a honeyed one); a manner that shows the person that he or she is considered worthy of respect and courtesy; a controlled volume to your voice."
  - f. *Make people feel important.* Give each person your full attention while he or she is speaking. Try to use his or her name when responding.
  - g. *Be honest with yourself.* "If you don't know the answers, refer the [person] elsewhere or admit that you don't know the answer. Don't make excuses and don't argue."
  - h. *Be presentable.* "Sloppiness suggests a lack of interest in oneself and therefore a lack of interest in others."
  - i. *Know when to terminate an interview.* "Don't lose the effectiveness of your discussion by letting it drag on. When you feel that the problem has been solved, you can courteously end the contact."
- 2 **Making a speech.** Before a speech, you must prepare the content, the visual aids, and yourself. In addition to the following summary, see Ref. 9 for valuable advice.
- a. *Preparing the material.* Write out what you want to say, but don't memorize it. Use the written text as a guide for compiling a set of notes and speaking naturally about the topic. Minimize the introductory part of the speech; get quickly into the meaningful material. End on a strong note; the last part of the speech is what most listeners will remember.
  - b. *Preparing visual aids.* Depending on the size of the audience, prepare flip charts, overhead transparencies, slides, or a computer-generated presentation. Make them uncluttered, with large, easy-to-read lettering. Follow the guidelines in Ref. 10. For example,
    - (1) Limit the title to one line, and the entire visual to 6–7 lines of text.
    - (2) Print your visual on 8½x11-inch paper and measure the text. The height of lowercase letters should be at least 5.6 mm (0.22 in).
    - (3) Use a sans-serif typeface; it is less cluttered.
 

☞ This is an example of a sans-serif font; the previous sentence is printed in a serif font—with little bars at the ends of the letters. ☞
    - (4) Use contrasting colors with a purpose in mind, not merely for decoration. Colors can distinguish between various elements (like two or more lines on a graph) or signal continuity from one image to another by using the same color for a particular element. Too many colors in a single visual will reduce contrast and legibility; use no more than four colors in a single visual.
  - c. *Preparing yourself.* "Research indicates that listeners are influenced more strongly by their attitudes toward the speaker than by the information presented." (Ref. 3) Even though you may not feel confident, you can act confident. Ref. 3 continues with the following tips:
    - (1) Rehearse. Practicing your delivery is essential. It helps you remember what you want to say and how you want to say it. It can help you recognize places in your talk where explanations or transitions are inadequate. And it helps you feel more confident when you make your presentation—you will be saying familiar things in a familiar order.
    - (2) Use a strong voice. Take a deep breath before beginning, talk in a confident tone, speak slowly, and enunciate clearly. Even when using a microphone, it is important to speak in a strong voice, both so the audience can hear you and so you will appear confident.
    - (3) Present a professional image. Dress appropriately for the occasion. Stand on both feet, and don't sway back and forth. Keep a relaxed, pleasant expression on your face. Consider not using a lectern even if one is available; it tends to create a barrier

between the speaker and the audience, and it tempts speakers to lean on it. Don't sit on the edge of a table.

- (4) Use appropriate gestures. Be careful about using phony, staged gestures just to give your hands something to do. However, if a gesture comes naturally, such as holding up four fingers to illustrate how many alternative designs your team considered, go ahead and use that gesture.
- (5) Establish eye contact. As you speak, let your gaze wander around the audience. Make eye contact with a few people, but don't stare at them. This will help keep the audience involved while giving you feedback on their understanding of what you are saying.
- (6) Use written notes, but do it unobtrusively.
- (7) Practice ahead of time with any equipment you are going to be using so you are familiar with how it operates and certain that it is in working order.
- (8) If you are not sure exactly what a questioner means, rephrase the question and ask if that is what he or she wants to know. Pause for a moment before giving your answer; this allows you to collect your thoughts and also makes the questioner feel that the question was important enough to think about. If appropriate, repeat the question into the microphone so the rest of the audience can hear it. Answer only the question that was asked—no more, no less. During your answer, establish eye contact with other audience members, not just the questioner.

3 **Legal testimony.** Legal testimony (giving a deposition or appearing in court) is a special case of public speaking. Many of the ideas discussed above are relevant. Here are some additional suggestions:

- a. Before testifying, consult with your firm or agency's legal staff.
- b. Listen carefully to the question you are asked. If you are not sure you understand exactly what the question is, ask for clarification. If you disagree with an assumption stated or implied in the question, say so. If you cannot answer the question without knowing (or assuming) additional details, say so. Answer the question truthfully and completely, but do not extend your answer beyond the scope of the question.
- c. If you don't know the answer to a question, admit it frankly. Don't guess or become defensive.
- d. If you are asked questions based on a graphic (e.g., a map or project plans), take time to orient yourself to the drawing before you answer the question. If there appears to be an error in the graphic that is relevant to the question you have been asked, mention that fact.
- e. Give your answers in clear, simple terms with a minimum of technical jargon. When you do use technical terms, explain their meaning.
- f. Resist the urge to feel intimidated. Remember that attorneys are just people who took different college courses than engineers.

## J. Conclusion

"Writing is not called a discipline for nothing. It is tough, wearing, brain-racking work." (James E. Porter in Ref. 3) Don't let this quote discourage you; rather let it ease any sense of embarrassment you may have felt about not being able to effortlessly crank out letters and reports.

## REFERENCES

1. Blake, G., and R. W. Bly. *The Elements of Technical Writing*. New York: Macmillan General Reference, 1993. 173 p.
2. *Writing Guidelines for Engineering and Science Students*. 2004. <http://www.writing.-eng.vt.edu>. (Feb. 2005).



3. Reep, D. C. *Technical Writing: Principles, Strategies, and Readings*. Boston: Allyn and Bacon, 1996. 604 p.
4. Tarutz, J. A. *Technical Editing: The Practical Guide for Editors and Writers*. Reading, MA: Addison-Wesley, 1992. 454 p.
5. "How to Avoid Technical Inconsistency and Maintain Credibility." *ITE Journal*, April 1997. pp. 44-45, 49-51.
6. Murray, M. and H. Hay-Roe. *Engineered Writing: A Manual for Scientific, Technical, and Business Writers*. Tulsa: PennWell, 1986. 292 p.
7. Petroski, H.. *Beyond Engineering*. New York: St. Martin's Press, 1986. 256 p.
8. Van Gelder, W. G. "Traffic Administration--Part A: Public Relations and Program Implementation." *Traffic Engineering Handbook*. Englewood Cliffs, NJ: Prentice Hall, 1992. pp. 419-429.
9. Lalani, N., and S. B. Colman. "Making Effective Technical Presentations." *ITE Journal*, January 1995, pp. 29-32, 37-38.
10. *Visual Aids: Information for Speakers on Preparing Visual Aids*. Washington, DC: Transportation Research Board, 2004. <http://www4.nas.edu/trb/annual.nsf/web/tips>.

## Index

- Accidents, collisions, Ch. 9
  - analysis, 9-1
  - bicycles, 21-4
  - California (SWTRS), 9-5, 20-5, T21-2
  - causes, 9-3
  - costs, 9-11, T9-2
  - countermeasures, 9-9
  - fatality rates, 9-2
  - on freeways, 25-1
  - rates, 9-7
  - severity index, 9-2
  - signal warrant, 19-7
  - time of day, 9-4, F9-2
  - in work zones, 26-1
- Accumulation
  - parking in CBD, 10-7
  - persons in CBD, F2-3
- Administration, 1-2, Ch. 35
- Air pollution, Ch. 30
  - automobile emissions, 30-4
  - control measures, 30-8
  - effects, 30-2
  - emission species, 30-2
  - emission standards, 30-8
  - legislation, 30-6
  - pollutant quantities, T30-1
  - sources, 30-3, T30-2
- Air quality
  - ambient standards, 30-6, T30-3
  - determinants, 30-1
- Air transportation, T2-1/2
- Alcohol, 3-4, 9-3
- All-way STOP control (also 4-way, multiway)
  - application, 19-3
  - capacity, 8-9
- Americans with Disabilities Act (ADA), 20-2
  - ADAAG, 20-2, 20-15
  - disabled persons parking, 27-7, T27-2
- Analysis zones, demand studies, 11-5
- Arterial (major) street/highway,
  - cross section, F17-1
  - network, 12-5
  - operations, Ch. 24
- Before-and-after studies
  - accidents, collisions, 9-3, A-7
  - speeds, 6-7
  - statistical methods, A-7
  - travel time, 7-2
- Bicycles, bicyclists, Ch. 21,
  - accidents, collisions, 21-4, T21-2/3/4/5, F21-2/3,
  - Bike paths, trails, 21-20
  - capacity, level of service, 8-10,
  - characteristics, 21-2,
  - dimensions, 21-2, F21-1
  - facilities, design, 21-14
  - legal context, rules of the road, 21-9
  - parking, 21-23
  - planning and policies, 21-11, 21-12,
  - provisions in TDM, 34-3
  - rights to the road, 21-10
- Binomial distribution, A-5
- Bottleneck, 4-3, F4-2
- Bus stops, 23-8, T23-3, 24-8
- Bus terminals, 27-11
- Buses and HOVs
  - bus-only streets, 24-9
  - exclusive roadways, 25-5
  - lanes, 24-9
  - preferential treatment, 24-8, 25-5
- California Environmental Quality Act (CEQA), 29-1
- Call boxes, 25-4
- Camera and video use for data collection,
  - land use studies, 11-4
  - parking inventories, 10-2
  - speed limit enforcement, 22-5
  - speed studies, 6-1
  - travel time studies, 7-3
- Capacity, Level of Service, Ch. 8
  - all-way STOP intersection, 8-9
  - bicycles, 8-10, T8-9/10/11
  - freeways, 8-4, T8-2/4
  - one-way street at intersection, 24-3
  - pedestrian flow, 8-9, 20-12, T20-9/10
  - roadways, 8-2
  - signalized intersections, 8-5
  - two-way STOP intersection, 8-8
- Capacity constraint, 11-14
- Central business district (CBD)
  - accumulation of persons, 2-10, F2-3
  - parking, 10-6
  - special traffic problems, 2-10
- Chi-square distribution, A-6, TA-2
- Classification counts, 5-2, 5-6
- Collision diagram F9-7
- Condition diagram, F9-6
- Confidence intervals, 6-7, A-2
- Conflict analysis, 9-9
- Congestion, 4-3, 7-2, 25-1, 26-1
- Congestion Management System (CMS), 12-2, 34-7
- Congestion Mitigation Program, 30-14
- Contraflow lanes
  - freeways, 25-7
  - streets, 24-8
- Control devices, Ch. 13-16
  - intersections, 19-2
  - markings, 14-9

Note: Page number references may include following pages.

Prefix letters: A - Appendix A, B - Appendix B, Ch - Chapter, F - Figure, T - Table

- signals, Ch. 15-16
- signs, 14-1
- speed zones, 22-3
- uniformity, Ch. 13
- Cordon counts, 5-2, 10-3
- Cordons, origin-destination studies, 11-5
- Counting programs, 5-4
- Courts, 1-4
- Crosswalks, 20-19
- Cumulative speed distribution, 6-8, F6-2
- Curb lane
  - accidents, collisions, 23-1, T23-1
  - loading zones, 23-7
  - use, 23-1
- Curb parking,
  - design of spaces, 23-3, F23-1
  - disabled drivers, 23-4
  - enforcement, 23-6
  - preferential program, 23-5
  - restrictions, 23-2
  - time limits, 23-3
- Curbs and curb radii, 17-5, 18-3, F18-2
- Curves,
  - horizontal, 14-12, 17-2
  - safe speed, 6-9
- Degrees of freedom, A-1
- Delay, Ch. 7
  - fixed, 7-1
  - intersection, 7-5
  - measurement, 7-2
  - operational, 7-1
  - stopped, 7-1
- Demand forecasting,
  - bicycling, 21-12
  - parking, 10-5
  - pedestrian, 20-11, T20-8
  - studies, Ch. 11
- Density, 4-2, 5-1, 8-1, T8-4
- Detectors
  - for actuated signals, 15-9
  - in freeway operations, 25-2
  - for traffic counting, 5-2
- Disabled persons, 3-4, T3-1
  - curb parking spaces, 23-3
  - off-street parking, 27-7, T27-2
- Drivers
  - alcohol and drugs, 3-4
  - elderly, 3-3, 3-5, T3-2, 9-4
  - licensing, 1-4, 33-3
  - perception-response time, 3-3
  - physical factors, 3-4
  - psychological factors, 3-4
  - vision, hearing, 3-1
- Driveway, 17-5, 23-1
- Dwelling unit survey, 11-8
- Efficiency, 2-1
- Energy, Ch. 32
  - consumption generally, 32-1
  - fuel economy of highway vehicles, 32-3, T32-3
  - impact of signals on fuel economy, 32-7
  - modal comparisons, 32-2
  - vehicle design factors, 32-3
  - vehicle operating factors, 32-5, T32-4
- Enforcement, 1-4
  - curb parking ordinances, 23-6
  - on freeways, 25-2
  - pedestrian laws, 20-5
  - speed laws, 22-5
- Environmental impact studies
  - CEQA process flow chart, F29-1
  - content, 29-1
  - exemptions, 29-2
  - form, 29-4
  - review of pedestrian network, 21-14
- Environmental impacts, 29-5
- Escalators, 20-22
- Expressway, cross section, F17-2
- Failure
  - systems, 3-5
  - vehicle failure and freeway operations, 25-1
- Fatal Accident Reporting Systems, 9-3
- Federal legislation
  - air quality, 30-6, 30-9
  - Americans with Disability Act (ADA), 15-4, 20-2
  - energy, 32-1
  - environment (NEPA), 29-1
  - ISTEA, 11-1, 12-1, 30-1, 34-1
- Flow (vehicles), 4-2
  - interrupted, 4-7
  - maps and charts, F5-1/2/3/4
  - rates, 8-3, T8-2
  - saturation, 8-3, 8-6
  - uninterrupted, 4-3, T8-2
- Four-way STOP control, See: All-way STOP control
- Freeways
  - capacity, level of service, 8-4
  - cross section, 17-6, F17-7
  - operations, Ch. 25
  - use by bicyclists, 21-18
- Friction coefficient, 3-10, F3-2
- Gaps, 4-2
- Geometric design
  - curb parking spaces, 23-3, F23-1
  - freeways, 17-3, 17-7
  - interchanges, 18-8, F18-6
  - intersections, 18-1, F18-1/2/3/4
  - off-street parking, 27-5
  - rural highways, 17-7
  - urban streets, 17-4, F17-1
- Growth factors, 11-10
- Hazard indices, 9-9
- Hazardous location identification, 9-7
- Headway, 4-2
- Hearing, 3-3
- High-occupancy vehicles (HOVs),
  - facilities, 34-3
  - HOV toll ("HOT") lanes, 25-9
- Highway network, 12-5
- Highway system, U.S., 2-4, T2-3
- Highways, rural, design guidelines, 17-7
- Highways, streets
  - design criteria, 17-1, T17-1
  - design speed, 17-2, T17-2
  - grades, 17-2, T17-2
  - horizontal curves, 17-2

- Households
  - demographic trends, T2-7
  - travel surveys, 11-6
  - vehicles available, T2-6
- Illuminance, 28-1, 28-10, T28-4
- Incident management, 25-4
- Institute of Transportation Engineers, 1-3, T1-1/2
- Interchanges
  - design elements, 18-11
  - types, 18-9, F18-6
- Intersections
  - channelization, 18-6
  - control, Ch. 19
  - delay studies, 7-5
  - design elements, 18-1
  - rotary, roundabout, 18-8, F18-5
  - safe approach speed, 19-8
  - sight distance, 18-1
- Interview studies
  - origin-destination surveys, 11-5
  - parking studies, 10-4
  - travel time studies, 7-4
- Inventories
  - land use, 11-4
  - network and traffic, 11-3
  - parking, 10-2
  - traffic control devices, 35-7
- Islands (pedestrian refuge), 18-6, 20-18
- Land Use
  - and air pollution, 30-10
  - and noise, 31-9
  - and TDM, 34-3
  - and plan implementation, 11-10
  - inventories, 11-4
  - parking demand, T10-2
  - trip generation, 11-10
- Lanes
  - continuous left turn, T17-3, 24-8
  - free right turn, 18-3, 19-12
  - left turn, 18-3
  - multiple turning, 19-11
  - number, 17-4, 17-7, T17-3
  - parking, 17-4, T17-3
  - width, 17-3, 17-7, T17-3
- Laws and ordinances, Ch. 33
  - basic speed rule, 22-1
  - pedestrian, 20-2
  - right-of-way rule, 19-1
- LED lamps
  - in signal heads, 15-2
  - in roadway lighting, 28-16
- Left turn movement, signal phasing, 19-1
- Legal responsibility, 33-6
- Legislation, See also: Federal legislation
  - federal, 33-1
  - state and local, 33-2
- Level of Service (LOS), See also: Capacity
  - defined, 8-2
  - LOS criteria, T8-3/4
  - maximum service flow rates, T8-2
  - pedestrians, 20-12
  - service measures, T8-1
- Liability, 21-10, 33-6
- License plate surveys,
  - curb parking studies, 10-3
  - origin-destination studies, 11-9
  - travel time studies, 7-4
- Lighting, Ch. 28
  - benefits, 28-15
  - definitions, 28-1
  - design, 28-9
  - lamps and ballast, 28-+4, T28-2/3
  - luminaires, 28-6, F28.1, T28-2/3
  - parking facilities, 28-15
  - poles, 28-8
  - tunnels, 28-15
  - vehicle headlights, 28-4
- Links, 2-1
- Luminance, 28-2, 28-11, T28-5
- Maintenance
  - freeways, 25-2
  - signals, 16-7
- Major Activity Center (MAC), 2-8
- Manual of Uniform Traffic Control Devices, 13-3, 14-1, 15-3, 19-2, 20-9, 21-17, 24-1, 26-1
- Markings, 14-9
- Mass (public) transit
  - improvements in TDM, 34-2
  - network planning, 12-7
  - origin-destination studies, 11-9
  - peaking characteristics, 2-10, F2-2
  - pedestrian access, 20-21
  - trips, by purpose, T2-7
- Materials spill, 25-2
- Median barrier, 17-8
- Medians, 17-7, 17-8
- Metering of freeway access, 25-2
- Metric system, vi
- Mobility, 2-1
- Modal split, mode choice, 11-13
- Mode of travel, 2-7, T2-8/10
- Model Traffic Ordinance, 13-4, 33-2
- Motor vehicle fuel composition, 30-9
- Motor vehicles
  - availability, 2-3, T2-4
  - deceleration, 3-8
  - detection, 5-2, 5-3
  - dimensions, 3-7
  - emission characteristics, 30-4
  - emission standards, 30-6
  - equipment and inspection, 33-9
  - fuel consumption, 32-2
  - magnetic imaging, 5-3
  - ownership, 2-3, F2-1, T2-4
  - performance, 3-8
  - statistics, 2-3, F2-1
  - stopping distances, 3-9
  - use, T2-5
- Motorcycles, 3-8, 9-3
- Networks, 2-1
- Noise, Ch. 31
  - abatement, 31-8
  - controls, 31-6
  - effect of pavement design, 31-10, F31-2
  - effects, 31-3
  - estimating, 31-5

- measurement, 31-5
- recommended limits, 31-7, T31-2/3/4
- sources, 31-3
- Noise barrier, 17-8, 31-9
- Off-street parking, Ch. 27
  - administration, 27-11
  - at airports, 27-4
  - bicycles, 21-22, T21-9
  - disabled drivers, 27-8, T21-9
  - fee collection, 27-10
  - financing, 27-2
  - garages, 27-7
  - geometric design, 27-5, F27-2/3/4/5/6
  - lighting, 28-15
  - location, 27-1
  - need, 27-1
  - at shopping centers, 27-4
  - at transit stations, 27-5
  - zoning requirements, 27-1
- One-way streets, 24-4
  - advantages, disadvantages, 24-1/2
  - control devices, 24-3
  - feasibility studies, 24-2
  - reversible, 24-4
- Origin-destination surveys
  - home interview, 11-8
  - mass transit passengers, 11-9
  - parking, 10-4
- Pace (speed distribution), 6-9
- Parking
  - accumulation, 10-1, 10-7, T10-2
  - accumulation counts, 10-7
  - curb, See: curb parking
  - duration, 10-1, 10-3, 10-7
  - inventories, 10-2
  - occupancy, 10-1, 10-7, F10-2
  - off-street, See: off-street parking
  - studies, 10-4
- Parking management, in TDM, 34-2
- Parking meters, 34-3
- Parking programs, residential areas, 23-6
- Passenger car equivalent, 8-1
- Peak Hour factor, 5-9
- Peak Hour signal warrant, 19-5
- Peaking patterns
  - rural highways, F5-1
  - urbanized areas, 2-10, F2.2, 5-9
- Pedestrians, Ch. 20
  - accidents, collisions, F20-4/5/6/7, T20-9
  - ADA considerations, 20-2
  - alcohol and drugs, 3-9
  - counts, 20-9
  - crosswalks, 20-19
  - flow characteristics, 20-9, F20-10
  - intersection design, 20-18
  - lighting, T28-4
  - overpasses, tunnels, 20-31
  - planning, 20-3
  - provisions in TDM, 34-3
  - sidewalks, walkways, 17-6, 20-15
  - signal warrant, 19-7
  - signals, 20-20, F20-17
  - at work sites, 26-4
- Perception-response time, 3-3
- Pipelines, T2-1/2
- Platoons, 4-3, 4-7
- Pneumatic road tubes, 5-2
- Poisson distribution, A-8
- Police intersection control, 19-3
- Population (in sampling), A-1
- Queueing analysis, 4-1, 4-3, F4-3/6
- Rail transit in freeway median, 17-8
- Railroads, T2-1/2
- Ramps, curb, 20-16, F20-11/12/13
  - detectable warning, 20-17,
  - on bike trails, 21-21F20-14
- Ramps, freeways,
  - bypasses, 25-6
  - capacity, 8-5
  - design criteria, 18-11
  - design speed, T18-1
  - location, 18-11
- Residential areas
  - parking programs, 23-6
  - traffic calming, 34-4
- Reversible lanes
  - control techniques, 24-5
  - examples, 24-6
  - feasibility studies, 24-5
  - operations, 24-4
- Right of way
  - control methods 19-2
  - regulation, 19-1
- Risk control programs, 33-9
- Rotary intersections (roundabouts)
  - capacity, 8-9
  - design, 18-8, F18-5
  - pedestrian design, 20-22
- Rules of the road, 33-5
- Safe approach speed, 19-8, F19-2
- Safe stopping distance, 3-12
- Sample
  - origin-destination studies, 11-6
  - selection, 6-2
  - size, 6-6, 7-3, 11-7, A-1
- School safety programs, 20-23
- Screen lines
  - counts, 5-2, 5-5
  - origin-destination studies, 11-3
- Service flow rate, 8-1
- Service volume
  - freeways, 8-3, T8-2
  - multilane highways, 8-3
- SI System of Measurements, vi
- Sidewalks, 20-15
- Sight distance
  - at intersections, 18-1, 18-8
  - safe passing, 14-13, T14-2
  - stopping, 17-3
- Signal systems, Ch. 16
  - computerized, 16-5
  - control philosophies, 16-5
  - interconnection, 16-1
  - maintenance, 16-7
  - SCAT, 16-7
  - SCOOT, 16-6

- timing, 16-3
- UTCS, 16-6
- Signalized intersections
  - capacity, British method, 8-6
  - capacity, level of service, 8-5
  - traffic flow characteristics, 4-7
- Signals
  - advantages, disadvantages, 15-1, 15-6
  - controller unit, 15-1, 15-3
  - detectors, 15-9
  - faces, 15-2
  - intersection control, 19-3
  - lane-use, 15-2, 24-5
  - pretimed, 15-3
  - traffic actuated, 15-6
  - turn on red, 19-11
  - warrants, 19-4
- Significance of differences
  - chi square test, A-7
  - Poisson distribution test, A-8
  - small sample studies, A-4
  - spot speed studies, 6-7, A-2
- Signs, 14-1
  - application, 14-6
  - design, 14-2, F14-1
  - location, 14-4
  - overhead, 14-5, 25-14, 28-12
  - supports, 14-5
- Skidding, 3-9
- Spacing, 4-2
- Speed
  - defined, 4-2
  - 85th percentile, 6-8, 22-4
  - limits, 22-1
  - mean, average, 4-2, 6-6
  - measurement, 6-3
  - median, 6-8
  - on curves, 6-9
  - running, 7-1
  - space-mean, 6-8
  - spot speed studies, Ch. 6, A-2
  - time-mean, 6-8
- Speed control, Ch. 22
  - coordinated signals, 22-4
  - enforcement, 22-5
  - funneling, 22-4
  - slow points, 34-4, F34-1
  - speed humps, 22-4
  - work zones, 26-4
  - zoning, 22-3
- Speed meter
  - laser, 6-4
  - radar, 6-4
- Speed recording
  - machine, 6-3
  - manual, 6-3
- Stability sensations, 3-3
- Standard deviation, 6-6, A-2
- Standard error of the mean, 6-6, A-2
- Statewide Integrated Traffic Records System, 9-4, 20-5, T21-2
- STOP control, 19-1, 19-2
  - capacity, 8-8
  - traffic flow characteristics, 4-8
- Street operation, Ch. 24
  - off-center movement, 24-7
  - reversible lanes, 24-4
- Streets
  - cross section, 17-3, T17-3
  - design speed, 17-2, T17-2
  - grades 17-2, T17-2
  - horizontal curves, 17-2
  - light rail transit in street, 24-9
  - local system, 12-5
- Surveillance of freeway traffic, 25-2
- Systems failure, 3-5, T3-3
- "t" distribution, A-3, TA-1
- Taxis, 11-8, 23-9
- Technical communications, B
- Telecommuting, 34-3
- Terminals, 2-1
  - bus, 27-12
  - planning, 12-7
  - truck, 27-12
- Test car technique, 7-2
- Traffic
  - diverted, 11-16
  - induced, 11-16
- Traffic calming, 34-4
- Traffic characteristics, studies, 1-1, Ch. 5 - 7
- Traffic control devices, Ch. 13 - 15
- Traffic Control Devices Handbook, 13-3
- Traffic control in work zones, Ch. 26
  - flagger control, 26-8
  - fundamental principles, 26-3
  - temporary control devices, 26-5
  - temporary control elements, 26-3
- Traffic counters
  - portable, 5-3
  - recording, 5-3
- Traffic counts, California program, 5-5
- Traffic engineering
  - administration, Ch. 35
  - defined, 1-1
  - functions, 35-1
  - legal authority, 35-5
  - organization, 35-1, 35-2, T35-2
  - profession, 1-2
  - responsibilities, 35-5, T35-1
  - scope, 1-1
  - staffing, 35-2, T35-1
- Traffic estimation, Ch. 11
- Traffic flow, See: Flow
- Traffic Management, Ch. 34
- Traffic operations and control, 1-2, Ch. 14 - 16, 19 - 26
- Traffic streams, Ch. 4
- Transportation characteristics, Ch. 2
- Transportation demand studies, Ch. 11
  - bicycle travel forecasting, 21-12
- Transportation engineering defined, 1-1
- Transportation facilities
  - functional classification, 12-3
- Transportation Improvement Program (TIP), 12-2
- Transportation planning, 1-1, Ch. 12
  - benefit-cost analysis, 12-8

- implementation problems, 12-10
- metropolitan, 12-2
- statewide, 12-3
- Transportation systems
  - general, 2-1, T2-1
  - U.S., 2-1, T2-2
- Transportation Systems Management (TSM), 34-1
- Travel characteristics,
  - peaking characteristics, 2-9, F2-2
  - trends, 2-3
  - urban, 2-7
- Travel Demand Management (TDM), 34-2
- Travel time, 4-2, Ch. 7
  - measurement equipment, 7-3
  - studies, Ch. 7, A-3
- Traveler Information System, 25-3
- Trip assignment, 11-14
- Trip distribution, 11-11
- Trip generation, 11-10
- Trip purpose, T2-8
  - parking, 10-4
- Trips
  - length, 2-6, 2-9, T2-6/9
  - length - bicycles, 21-4
  - quantities, T2-6
  - urban quantities, 2-9, T2-10
- Trucks, T2-2/3
  - combinations, T2-5
  - pickup, T2-10
  - origin-destination studies, 11-8
  - single unit, T2-5
  - terminals, 27-11
- Turning lanes, See: lanes
- Turning movement
  - counts, 5-2
  - prohibition, 19-10
  - special turning maneuvers, 19-11
- Two-lane highways
  - capacity, level of service, 8-4
- Two-way STOP control, 19-2
  - capacity, level of service, 8-8
- U-turns, 19-11
- Ubiquity, 2-1
- Uniform Vehicle Code, 13-4, 33-2
- Uniformity
  - laws, 33-2
  - traffic control devices, 13-2
- Video imaging, 6-4
- Video surveillance, 25-2
- Vision, 3-1
  - color, 3-1, 28-4
  - cone of vision, 3-1, F3-1, 14-5,
  - discernment, 28-2
  - glare, 3-1, 28-4
  - visibility, 28-3
- Volumes
  - annual average daily traffic (AADT), 5-1
  - counting programs, 5-4, 5-5
  - design hourly, 5-9
  - recording equipment, 5-3
  - urban characteristics, 5-9
- Water transport, T2-1/2
- Weaving sections, capacity, 8-4
- Wheelchair ramps, 20-16
- With-flow reserved lanes
  - curb, 24-8
  - freeways, 25-6
- Work zones, Ch. 26
  - freeway maintenance, 25-2
- YIELD control, 19-1, 19-2
  - traffic flow characteristics, 4-8
- Zoning
  - off-street parking facilities, 27-1, T27-1
  - speed limits, 22-3

---

## ERRATA

Page 10-7, Fig. 10-2:

In the caption, CDB should read CBD.

Page 15-4, Eq. [15.1]:

The 4th line below the equation should read:

$g$  = percent grade (negative for up, positive for down)

Page 17-2, Table 17-1:

The correct title for the table is "Design Criteria of Highway Types."

For the most recent updates, visit the *Fundamentals* Web site at

<http://www.its.berkeley.edu/fundamentals/>





