

Lawrence Berkeley National Laboratory

Recent Work

Title

SECOND VERSION OF A CONSTANT FRACTION TRIGGER REDESIGNED WITH NEW INTEGRATED CIRCUITS AND RESULTS WITH SEMICONDUCTOR DETECTORS

Permalink

<https://escholarship.org/uc/item/1tc5k9sw>

Authors

Maier, Michael R.

Landis, Donald A.

Publication Date

1973-10-01

**SECOND VERSION OF A CONSTANT FRACTION TRIGGER
REDESIGNED WITH NEW INTEGRATED CIRCUITS
AND RESULTS WITH SEMICONDUCTOR DETECTORS**

Michael R. Maier and Donald A. Landis

October 1973

Prepared for the U. S. Atomic Energy Commission
under Contract W-7405-ENG-48

For Reference

Not to be taken from this room

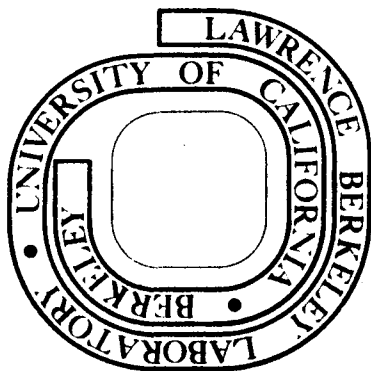

DISCLAIMER

This document was prepared as an account of work sponsored by the United States Government. While this document is believed to contain correct information, neither the United States Government nor any agency thereof, nor the Regents of the University of California, nor any of their employees, makes any warranty, express or implied, or assumes any legal responsibility for the accuracy, completeness, or usefulness of any information, apparatus, product, or process disclosed, or represents that its use would not infringe privately owned rights. Reference herein to any specific commercial product, process, or service by its trade name, trademark, manufacturer, or otherwise, does not necessarily constitute or imply its endorsement, recommendation, or favoring by the United States Government or any agency thereof, or the Regents of the University of California. The views and opinions of authors expressed herein do not necessarily state or reflect those of the United States Government or any agency thereof or the Regents of the University of California.

SECOND VERSION OF A CONSTANT FRACTION TRIGGER
REDESIGNED WITH NEW INTEGRATED CIRCUITS
AND RESULTS WITH SEMICONDUCTOR DETECTORS*

Michael R. Maier[†] and Donald A. Landis

Lawrence Berkeley Laboratory
University of California
Berkeley, California 94720

ABSTRACT

A design of the constant fraction trigger with recently introduced integrated circuits is given. Results are quoted for the time resolution with germanium detectors. These were obtained with a circuit modification to suppress tails in the time spectra associated with slow rising pulses.

A previous paper¹⁾ described the design of a constant fraction trigger (CFT) with integrated circuits (IC) of the MECL II series. Recently a fast ECL-comparator²⁾ became available, which allows a simpler implementation of the CFT. The unit described in this letter uses these comparator ICs together with the MECL 10 K series³⁾.

The new unit differs from the original design in that a circuit is included for the suppression of pulses having slow rise times. This has the effect of removing the tails on peaks in the time spectra associated with slow rising pulses in germanium detectors. The method proposed by F. Gabriel, et al^{4,5)} is used because it is simpler to implement with IC than the methods proposed by other authors^{6,7)}. This slow rise-time

* This work was done under the auspices of the United States Atomic Energy Commission.

† On leave from Physik Department der TU München, 8046 Garching

suppression circuit inhibits the output of the unit when the output signal of the leading edge discriminator (LED) IC occurs after the signal of the CFD IC.

A block diagram of the unit is given in Fig. 1. The slow rise-time suppression circuit can be switched off, as well as the CFD IC, so that the unit can be used as a CFD with slow rise time suppression, as a normal CFD, or as a leading edge discriminator. The basic circuit is similar to that of Ref. 1). However, the new design omits the one-shot for the slow NIM output. The slow NIM output signal here is derived from the dead-time one-shot via a MECL-to-TTL translator IC (e.g. MC1068, or MC10125).

The slow rise-time suppression circuit results in a slight loss in efficiency for low-energy gamma rays when using germanium detectors, because even normal rise-time signals of low amplitude trigger the LED IC later than the CFD IC. Experiments⁸⁾ show that the detection efficiency of a 8 cm³ planar intrinsic germanium detector is appreciably affected only below about 150 KeV gamma energy. Below this energy the efficiency decreased linearly with energy. For a 30 cm³ coaxial lithium drifted germanium detector the loss in efficiency starts at about 250 KeV. These results were obtained when the unit was driven by a signal derived by differentiating (500 ns RC) the output of a charge-sensitive preamplifier. If the fast input signal to the unit is properly integrated, the energy where loss in efficiency occurs moves lower.

The slow rise-time suppression circuit results in time distribution curves with very clean exponential tails (Fig. 2). This is a big advantage when measuring short life times. When the loss in detection efficiency at low energies is a more important problem, the CFT can be used in the normal mode.

Pulser tests on 12 units show good performance over an input signal amplitude range of -5 mV to -5 V. The walk for this range, was 1 ns, using an input pulse with a rise time of 2 ns. Corresponding tests with the circuit from Ref. 1) with a CA3026 as first stage gave a much lower useful dynamic range (-100 mV to 5 V), but the walk over that range was less than 250 ps⁹⁾. The time resolution with a narrow range of input amplitudes (2:1) is about the same for both units. Therefore the new unit, which is simpler to build than the one from Ref. 1), is useful for experiments where the requirement for energy-dependent walk are not very stringent, (e.g. Ge detector γ - γ coincidences), or where this walk can be corrected. In experiment where that walk has to be minimized, e.g. neutron time-of-flight experiments, the original circuit is better suited although not as versatile as the new one.

Timing results obtained with different combinations of germanium detectors are given in the table. The figures were obtained in experimental set-ups at the 88" Cyclotron and the Super HILAC accelerator at the Lawrence Berkeley Laboratory⁸⁾. By restricting the amplitude ranges presented to the CFT the figures may even be improved.

The unit is contained in a single width NIM module, although the front panel space is barely sufficient to accommodate all connectors and controls. The circuit is built on a printed circuit board with a ground plane on one side. The layout of the input stage is very critical, since the high gain of the discriminator IC makes it very susceptible to spurious oscillations.

ACKNOWLEDGEMENT

We wish to thank Fred S. Goulding for the interest and support he has provided for this project.

REFERENCES

1. M. R. Maier and P. Speer, Nucl. Instr. and Methods, 87, No. 1, 13 (1970).
2. F. N. Siles and H. Seales, Electronics 45, 112 (1972).
3. See the data sheet of the Motorola MECL 10 K Series. This IC series is available from many other manufacturers.
4. F. Gabriel, H. Koepf and K. Schöps, Nucl. Instr. and Methods, 103, No. 3, 501 (1972).
5. Y. K. Akimov, K. Andert, A. I. Kalinin and H. -G. Ortlepp, IEEE Trans. Nucl. Sci., NS-19, No. 3, 404 (1972). And Nucl. Instr. and Methods, 104, 581 (1972).
6. Z. H. Cho and R. L. Chase, IEEE Trans. Nucl. Sci., NS-19, No. 1, 451 (1972).
7. B. Bengtson and M. Moszynski, Nucl. Instr. and Methods, 100, No. 2 293 (1973).
8. A. Gizon and J. Gizon, et al, to be published in Nucl. Phys.
9. C. C. Loo and B. Leskovar, private communication regarding the evaluation of the fast constant fraction as described in Ref. 1 above.

TABLE 1

TIMING RESULTS WITH DIFFERENT DETECTORS AND ^{22}Na RADIATION			
	FWHM	FW 0.1 M	FW 0.01 M
8 cc planar V 30 cc coax dets. E > 80 KeV	6.3 ns	14.3 ns	25.8 ns
Two 60 cc coax dets. (see Fig. 2) E > 80 KeV	11.2 ns	21.2 ns	34.8 ns

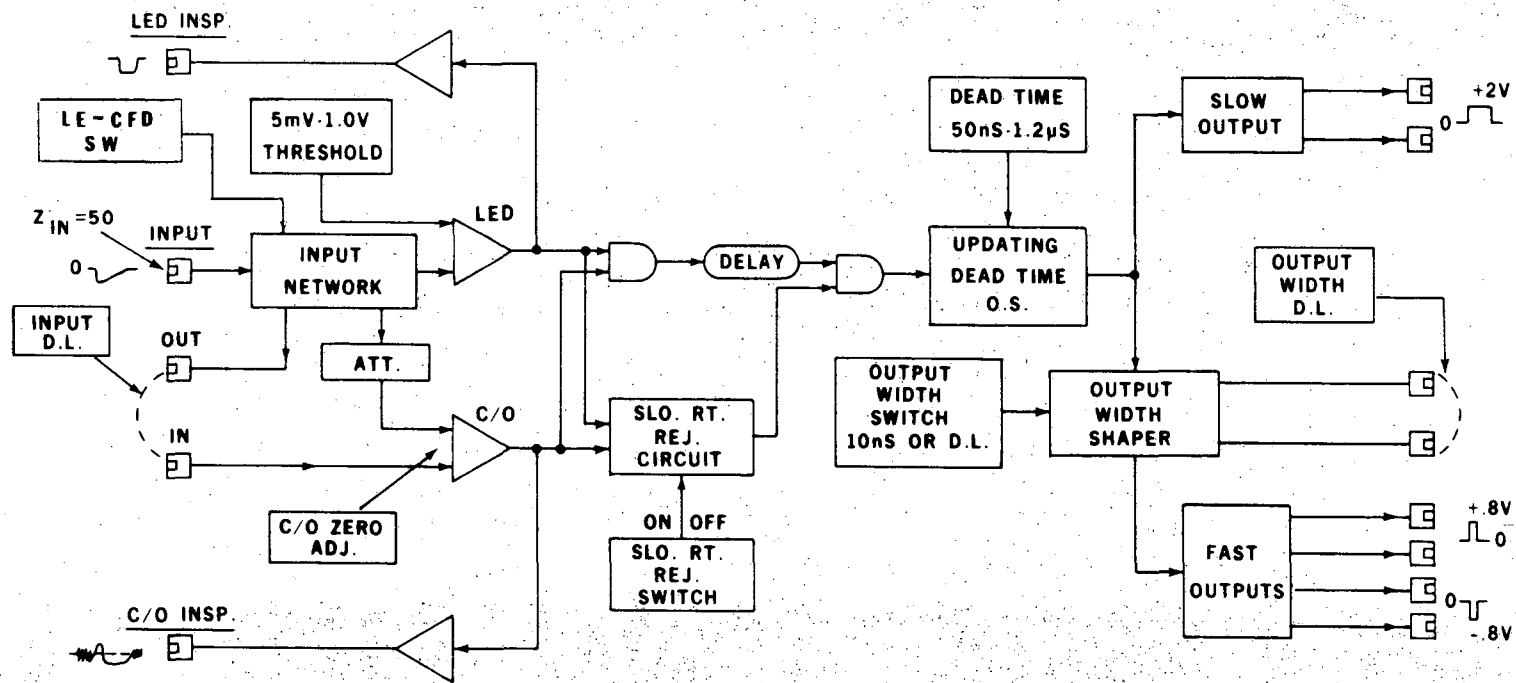
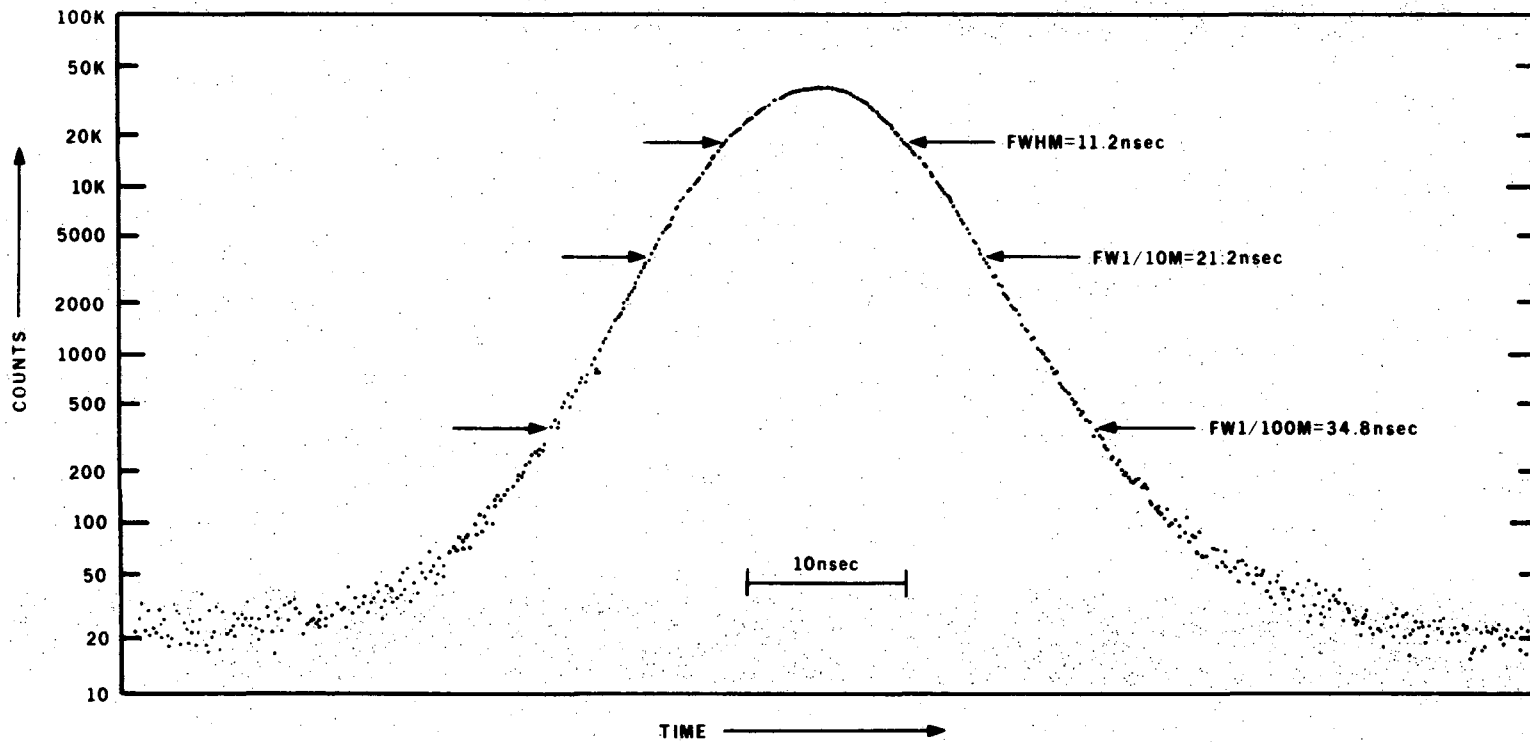

Fig. 1. Block diagram of the new constant fraction trigger.

XBL 734-381



XBL 739-1251

Fig. 2. Prompt curve obtained with a ^{22}Na source between two 60 cm^3 true-coaxial lithium drifted germanium detectors. The break in the gamma detection efficiency was about 250 KeV.

LEGAL NOTICE

This report was prepared as an account of work sponsored by the United States Government. Neither the United States nor the United States Atomic Energy Commission, nor any of their employees, nor any of their contractors, subcontractors, or their employees, makes any warranty, express or implied, or assumes any legal liability or responsibility for the accuracy, completeness or usefulness of any information, apparatus, product or process disclosed, or represents that its use would not infringe privately owned rights.

TECHNICAL INFORMATION DIVISION
LAWRENCE BERKELEY LABORATORY
UNIVERSITY OF CALIFORNIA
BERKELEY, CALIFORNIA 94720