

Lawrence Berkeley National Laboratory

Lawrence Berkeley National Laboratory

Title

CHAMPS-Multizone?A Combined Heat, Air, Moisture and Pollutant Simulation Environment for Whole-building Performance Analysis

Permalink

<https://escholarship.org/uc/item/1mn6v4kb>

Author

Feng, Wei

Publication Date

2012-06-30

DOI

10.1080/10789669.2011.587585

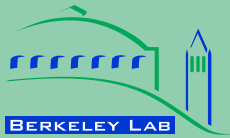

ERNEST ORLANDO LAWRENCE
BERKELEY NATIONAL LABORATORY

CHAMPS-Multizone—A Combined Heat, Air, Moisture and Pollutant Simulation Environment for Whole-building Performance Analysis

Wei Feng

China Energy Group

Environmental Energy Technologies Division

Lawrence Berkeley National Laboratory

**John Grunewald, Andreas Nicolai, Carey Zhang,
J.S. Zhang**

*Reprint version of journal article published in “HVAC&R
Research”, Volume 18, Issue 1-2, 2012*

June 2012

This work was supported by the U.S. Department of Energy under Contract No. DE-AC02-05CH11231.

Disclaimer

This document was prepared as an account of work sponsored by the United States Government. While this document is believed to contain correct information, neither the United States Government nor any agency thereof, nor The Regents of the University of California, nor any of their employees, makes any warranty, express or implied, or assumes any legal responsibility for the accuracy, completeness, or usefulness of any information, apparatus, product, or process disclosed, or represents that its use would not infringe privately owned rights. Reference herein to any specific commercial product, process, or service by its trade name, trademark, manufacturer, or otherwise, does not necessarily constitute or imply its endorsement, recommendation, or favoring by the United States Government or any agency thereof, or The Regents of the University of California. The views and opinions of authors expressed herein do not necessarily state or reflect those of the United States Government or any agency thereof, or The Regents of the University of California.

Ernest Orlando Lawrence Berkeley National Laboratory is an equal opportunity employer.

NOTICE: this is the author's version of a work that was accepted for publication in HVAC & R Research. Changes resulting from the publishing process, such as peer review, editing, corrections, structural formatting, and other quality control mechanisms may not be reflected in this document. Changes may have been made to this work since it was submitted for publication. A definitive version was subsequently published in HVAC & R Research, Volume 18, Issue 1-2, 2012, Pages 233-251.

Heat, Air, Moisture and Pollutant Simulation Environment for Whole-building Performance Analysis

Wei Feng, John Grunewald, Andreas Nicolai, Carey Zhang, J.S. Zhang

ABSTRACT

A computer simulation tool, named "CHAMPS-Multizone" is introduced in this paper for analyzing both energy and IAQ performance of buildings. The simulation model accounts for the dynamic effects of outdoor climate conditions (solar radiation, wind speed and direction, and contaminant concentrations), building materials and envelope system design, multizone air and contaminant flows in buildings, internal heat and pollutant sources, and operation of the building HVAC systems on the building performance. It enables combined analysis of building energy efficiency and indoor air quality. The model also has the ability to input building geometry data and HVAC system operation related information from software such as SketchUp and DesignBuilder via IDF file format. A "bridge" to access static and dynamic building data stored in a "virtual building" database is also developed, allowing convenient input of initial and boundary conditions for the simulation, and for comparisons between the predicted and measured results. This paper summarizes the mathematical models, adopted assumptions, methods of implementation, and verification and validation results. The needs and challenges for further development are also discussed.

KEYWORDS

Building simulation, Energy simulation, Indoor Air Quality, Building Performance, Multizone model

INTRODUCTION

Various building simulation programs have been developed (Crawley 2001, Walton 2006, Crawley 2007, and Nicolai 2007). However, a simulation tool for combined energy efficiency and IAQ analysis is not yet available. With the development of building technology, simulation programs are needed to enable architects and engineers to predict the energy and IAQ performance throughout different design stages, and at the time of building operation for diagnostic purposes. The objective of this study is to develop such a program (named, CHAMPS-Multizone) for whole building performance simulation. It enables the simulation of combined heat, air, moisture, and pollutant transport in a multizone building, which are needed for concurrent building energy efficiency and IAQ analysis. The development effort started in 2007, with the initial intent to couple thermal effects on the emission of volatile organic compounds from building materials and the impact on IAQ. The initial program was developed in Borland C++ Builder environment by using existing CHAMPS-BES (coupled heat, air, moisture and pollutant simulation for building envelope systems, Nicolai et al. 2007) program as building enclosure model. In 2008, the user-interface was restructured using MS VC++/QT environment. In 2009, several new model and features were implemented into the model including: 1) a new Building Information Modeling (BIM) class/data structure; 2) implementation of solar radiation and heat transfer models; 3) HVAC and control models; 4) modules for data input from SchetchUp and DesignBuilder in 2010, and 5) a redesigned user interface for compatibility with the "Virtual Building" database and ease of data input.

The current paper provides an overview of the program structure and components/modules, detailed description of mathematical models and associated assumptions, method of numerical implementation, and data interoperability with Google SchetchUp (2009), DesignBuilder (2009) and the "Virtual Building" database that was developed to represent digitally the characteristics and operation conditions of a real building (Feng et al. 2009). The simulation results from CHAMPS-Multizone are also compared with the results obtained separately from existing well-established building simulation programs, EneyPlus (2008) for energy analysis and CONTAM (Walton 2006) for IAQ analysis.

MODEL DEVELOPMENT

An overview of combined heat, air, moisture and pollutant simulation (CHAMPS) program for a whole building is illustrated in Figure 1. The program includes three component models for building envelope, HVAC and room simulation and a multizone model that integrates the component models for whole building performance simulation. The program is supported by a shared database called "Virtual Building" which provides static building data (including

construction materials, building geometry etc.) as well as dynamic data on real-time building performance monitoring. The program is used to simulate various design or control parameters to predict the performance of building energy and environmental systems. A VOC emission database will also be part of the shared databases for evaluating the effects of sources as well as ventilation and air cleaning on IAQ.

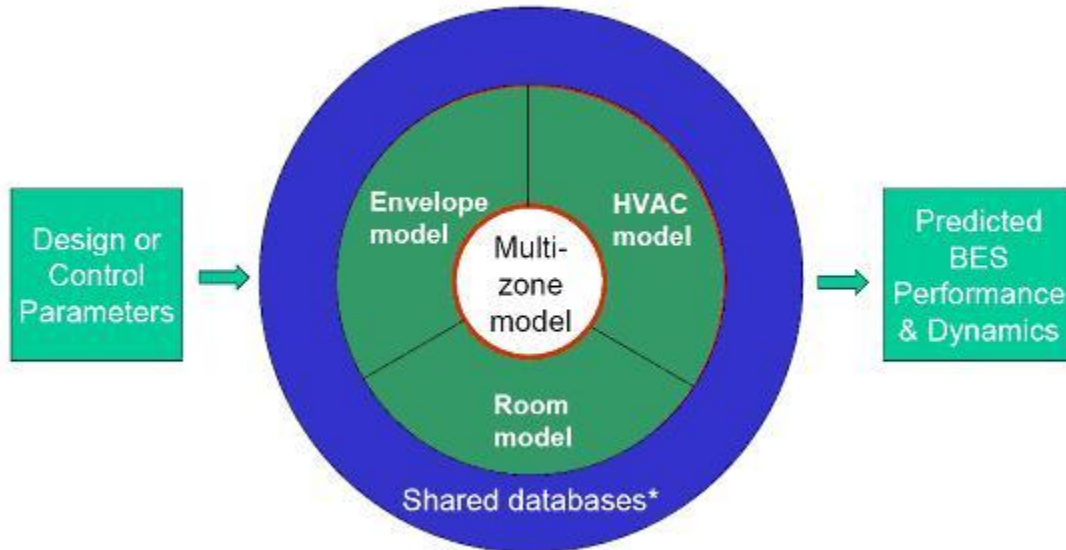

Figure 1 CHAMPS program structure

Source: (Zhang 2005)

Furthermore, CHAMPS-Multizone can be used for building design analysis to study building energy and IAQ performance. As Figure 2 shows, in early design stage, when building information input is simple, CHAMPS-Multizone can simulate building's energy, moisture and indoor air quality without considering detailed HVAC plant systems. In detailed design stage, CHAMPS-Multizone can integrate with CHAMPS-BES and EnergyPlus for detailed building envelope and HVAC systems simulation. Thus, based on different design stages, CHAMPS-Multizone can coordinate various models to accommodate needs of building performance analysis.

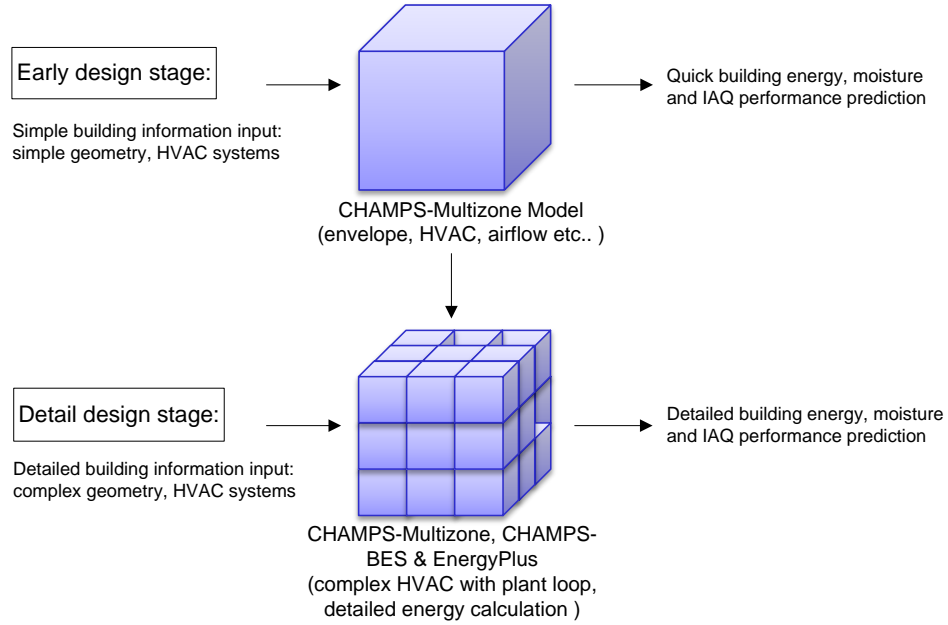

Figure 2. CHAMPS-Multizone and building design analysis

Mathematical Models:

1) Multi-zone air-flow network model:

The air-flow network model calculates the amount of air flow and pressure difference across external building envelope cracks/openings, internal partitions and floors. The driving forces for the air flow include wind and thermal buoyancy induced pressure differences across the building enclosure and fan induced pressure rises. Since pressure fluctuation transmits in the speed of sound, exceedingly faster than the heat and mass transport processes in the building, any zone pressure change process can be considered instantaneous. And hence a quasi-steady state air flow model is adopted:

$$\frac{\partial \rho_i^{air}}{\partial t} = \frac{1}{V_{zone,i}} \sum_j^N (s_{i \rightarrow j} K_g |p_i - p_j|^{n_{i \rightarrow j}}) = 0 \quad (1)$$

or simplified as,

$$\sum_j^N (s_{i \rightarrow j} K_g |p_i - p_j|^{n_{i \rightarrow j}}) = 0 \quad (2)$$

where,

p_i = zone i pressure field (pa),

p_j = zone j (connected with zone i) pressure field (pa),

$V_{zone,i}$ = zone i volume (m^3),

K_g = air flow coefficient ($kg\ m^3/pa^n$),

$n_{i \rightarrow j}$ = flow exponent from zone i to zone j,

$s_{i \rightarrow j}$ = flow direction sign, 1 if $p_i < p_j$, and -1 if $p_i \geq p_j$.

Equation (2) requires solving all zones' pressure fields simultaneously. Once all zone's pressure is solved, the air flow rate can be calculated by using the flow rate-pressure relationship that characterizes the specific openings. The calculated heat, moisture and pollutants flow carried by airflow is considered as fluxes to the zone/room in the zone/room balance equations (i.e., room model).

2) Room model:

Well-mixed zone/room assumption is adopted in CHAMPS-Multizone. Another important assumption is that moisture (water vapor) and pollutant(s) are considered as trace gas so that their density change will not affect the zone's air density.

A general zone balance governing equation is given as:

$$V \frac{\partial \rho^E}{\partial t} = \sum j^E + \sum \sigma^E \quad (3)$$

where,

E = extensive property,

$E = U$ for energy, $E = m_v$ for water vapor, $E = p$ for pollutant,

ρ = zone density variable for extensive property E ,

j = flux for extensive property E ,

σ = source sink term for extensive property E .

Equation (3) can be further written as,

$$V \frac{\partial \rho^E}{\partial t} = \sum j_{conv}^E + \sum j_{airflow}^E + \sum j_{hvac}^E + \sum \sigma^E \quad (4)$$

where,

j_{conv}^E = convective transfer from construction interior surface for extensive property E ,

$j_{airflow}^E$ = air flow (infiltration, exfiltration, inter-zonal flow) transport for extensive property E ,

j_{hvac}^E = HVAC transport for extensive property E .

For CHAMPS-Multizone application, three equations can be further derived from equation (4) for energy, moisture mass and pollutant mass balance respectively. The unknowns of zone quantities balance equation are zone internal energy density ρ^U in [J/m³], moisture mass density ρ^{m_v} in [kg/m³], and pollutant density ρ^p in [kg/m³].

For more detailed simulation of the spatial distribution of room air and air contaminant, another room model that is based on subzoning approach has been developed (Nicolai 2010), which will be coupled with CHAMPS-Multizone during the next stage of the CHAMPS program development.

3) HVAC model:

The HVAC air system model assumes that supply duct and return duct of air handling unit could be considered as well-mixed "zones", so that zone balance model, introduced in room model section, can be used here. This assumption is widely adopted by most IAQ simulation programs such as CONTAM (2009) for simplified HVAC modelling. A schematic of HVAC air handler system is illustrated as in Figure 3.

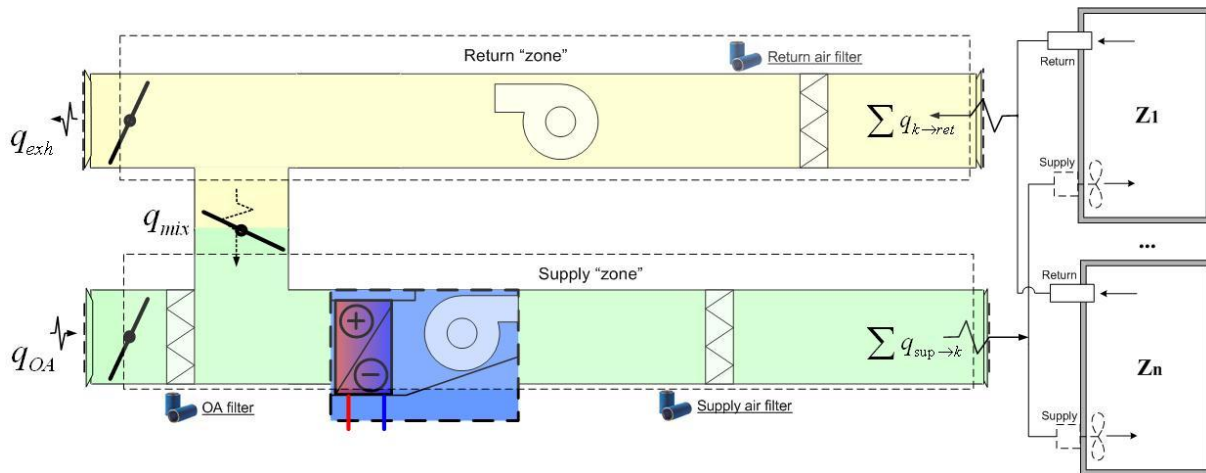

Figure 3 Modelling of HVAC air handler as supply and return "zones"

Filters can be simulated in supply or return "zones" as well as outdoor air supply duct. The air distribution from the air handling unit to individual zones are specified by user input directly or based on the heat and mass balance requirements for each zone with the assumption that subsequent detailed duct design would ensure the balance of airflow and pressure in the building air distribution system to meet the requirements. Heat loss, gain and leakages along the air distribution ducts are not accounted in this simplified HVAC model. Since plant loop simulation is not included in this study, current model is limited to the net energy required to condition the supply air for achieving the desired set points without considering the equipment efficiency. For more detailed analysis, a coupling method is being developed for CHAMPS-Multizone to utilize the functionalities in the EnergyPlus program (Gu 2010).

Supply and return duct balance governing equations are given as Equations (5) and (6), respectively:

$$V_{sup} \frac{\partial \rho_{sup}^E}{\partial t} = q_{OA} (1 - \eta_{OA}^E) \rho_{OA}^E + q_{mix} \rho_{ret}^E - \sum_k^N q_{sup \rightarrow k} (1 - \eta_{out}^E) \rho_{sup}^E \quad (5)$$

$$V_{ret} \frac{\partial \rho_{ret}^E}{\partial t} = \sum_k^N q_{k \rightarrow ret} (1 - \eta_{ret}^E) \rho_k^E - q_{exh} \rho_{ret}^E - q_{mix} \rho_{ret}^E \quad (6)$$

where,

V_{sup} = supply duct volume (m³)

$q_{sup \rightarrow k}$ = supply air flow rate from supply duct to zone k (m³/s)

$q_{k \rightarrow ret}$ = return air flow rate from zone k to return duct (m³/s)

q_{mix} = mix air flow rate, from return duct to supply duct (m³/s)

q_{exh} = exhaust air flow rate, from return duct to ambient air (m³/s)

ρ_{sup}^E = supply air duct "zone" extensive property E density

ρ_{ret}^E = return air duct "zone" extensive property E density

η^E = filter efficiency for extensive property E

Two different types of HVAC system are considered in CHAMPS-Multizone, constant air volume (CAV) and variable air volume (VAV), which are the most common for buildings. For CAV system, the supply air volume to individual zone is constant and defined by user input; while the supply air temperature is calculated in terms of the zone heat balance. Return air flow rate can also be specified, and can be different from supply air flow rate to pressurize or depressurize a zone. For VAV system, the supply air temperature is user-specified and supply air flow rate is controlled to ensure the zone heat balance.

4) Envelope model:

Two models are considered for energy and mass transport through building enclosure system. The first model uses finite volume method, to calculate the 1D or 2D heat, air, moisture, and pollutant transport through building enclosure. This model has been developed by Nicolai (2007) and a simulation program called CHAMPS-BES was developed for building envelope system analysis. It was coupled with CHAMPS-Multizone to provide fluxes of heat, moisture and volatile organic compounds through wall surfaces (Nicolai et al. 2007).

Another model uses Conduction Transfer Function (CTF) method to calculate energy transport through building envelope. This can provide much faster energy simulation than the finite volume method used in CHAMPS-BES, and accurate results for energy transport analysis. Uniform temperature distribution on the exterior and interior surfaces of one construction assembly is assumed. The exterior and interior surface heat balance equations are given in Equations (7) and (8), respectively:

$$j_{sol}^U + j_{lw}^U + j_{conv}^U - j_{ko}^U = 0 \quad (7)$$

$$j_{sol}^U + j_{lwx}^U + j_{conv}^U + j_{ki}^U + j_{sws}^U + j_{lws}^U = 0 \quad (8)$$

where,

j_{sol}^U = short wave solar radiation (W/m²),

j_{lw}^U = long wave radiation exchange between ambient environment and exterior surface (W/m²),

j_{lwx}^U = long wave radiation exchange between interior surface (W/m²),

j_{conv}^U = convective heat transfer on interior surface (W/m²),

j_{ko}^U = heat conduction out of exterior surface (W/m²),

j_{ki}^U = heat conduction into interior surface (W/m²),

j_{sws}^U = short wave source radiation imposed on interior surface (lighting source) (W/m²),

j_{lws}^U = long wave source radiation imposed on interior surface (e.g. equipment, people.) (W/m²).

The conduction heat flux on exterior and interior building envelope surface is given in equation (9) and (10) respectively:

$$j_{ko}^U(t) = -Y_0T_{i,t} - \sum Y_jT_{i,t-l\delta} + X_0T_{i,t} + \sum X_jT_{o,t-l\delta} + \sum \Phi_l j_{ko,t-l\delta}^U \quad (9)$$

$$j_{ki}^U(t) = -Z_0T_{i,t} - \sum Z_jT_{i,t-l\delta} + Y_0T_{i,t} + \sum Y_jT_{o,t-l\delta} + \sum \Phi_l j_{ki,t-l\delta}^U \quad (10)$$

where, X, Y, Z are temperature coefficient and Φ is conduction flux coefficient obtained from a CTF generator program (lu 2009).

5) Multi-zone model simulation manager:

All the component models introduced above are managed by a multi-zone model simulation manager to conduct multi-zone quantity balance calculation. A zone integrator serves as the central part of the multi-zone model simulation manager which controls quantities balance as Equations (3) and (4) give. The building envelope model solves construction interior surface convection term j_{conv}^E by calculating interior surfaces' temperature, moisture density, and pollutant density with given convective heat, moisture and pollutant transfer coefficient. And the fluxes from building envelope interior surfaces are considered in the zone balance model and integrated. Air-flow transport flux term $j_{air\ flow}^E$ is solved by air-flow network model and also integrated in the zone balance model. HVAC transport flux term j_{hvac}^E , calculated from HVAC model, provides supply and return duct air flow quantities. The advantage of adopting a multi-zone model simulation manager is that it offers flexibility that allows multiple component models to co-exist in the CHAMPS-Multizone framework. The simulation manager interacts with different component model and passing information between each other. For example, both CTF and CHAMPS-BES building envelope models are allowed in CHAMPS-Multizone framework, and the simulation manager determines which one to call based on user's input. In

the early or conceptual design stage, the CTF envelope model is sufficient for whole building energy performance analysis. At the final design stage, more detailed simulation of the envelope systems can be conducted by calling the CHAMPS-BES. The multizone simulation manager concept and how variables are transfer between different models is further illustrated by Figure 4.

Numerical methods and solver schemes:

Multiple numerical solver schemes are implemented in CHAMPS-Multizone C++ program to solve different models. The solver schemes include solar radiation solver, building envelope solver, zone and HVAC solver, and air-flow solver. An implicit variable-order variable-step Newton method is used to solve most of models in CHAMPS-Multizone. A Ping-pong solver integration scheme is implemented in CHAMPS-Multizone to exchange solver variables between different schemes as Figure 4 illustrated.

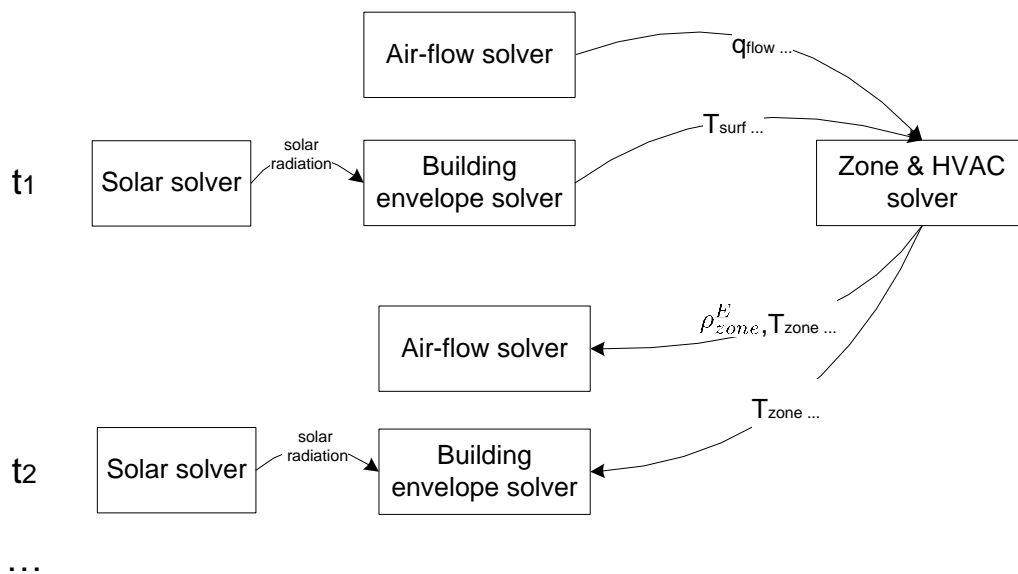

Figure 4 Schematic of solver integration by the simulation manager

Air-flow model solves for pressures in all zones, and then calculates the air-flow rates between zones. Building envelope model calculates construction interior surface temperature, moisture concentration, and pollutant(s) concentration.¹ Then the solved air-flow quantity and interior construction surface quantities is used by zone & HVAC solver to conduct multi-zone calculation.

¹ Alternatively, building envelope model can calculate flux terms from interior surface into zones, and then zone model uses the calculated fluxes for zone balance calculation. However, zone model turns out to have better numeric convergence and stability when using interior surface state variable (temperature, concentrations) compared with using fluxes.

After zone & HVAC solver finishes zone extensive properties balance calculation, the zone extensive properties are used for next step's air-flow, and building envelope solver calculations.

Models in CHAMPS-Multizone are solved by implementing SUNDIALS C numeric solver package developed by Lawrence Livermore National Lab (LLNL). Differential equations are solved by applying CVODE package developed by Hindmarsh (2006), and non-linear equations (e.g. air-flow model) are solved by applying KINSOL package developed by Collier (2006). Since the numeric package provides automatic adjustment of model's order and step, the program can perform calculation in decent speed. It is tested that CHAMPS-Multizone can solve energy, moisture, and pollutant balance for a three-zone building case with one air handling unit in one minute, simulated in a computer with an AMD Athlon 64*2 Dual Core Processor 2.19GHz and 3GB RAM.

Data exchange modules:

CHAMPS-Multizone can interact with other simulation or design software to easily get building geometry and materials data. Current implementation makes it possible for importing *.idf (EnergyPlus Input Data File) file which can be easily exported from building modelling software like DesignBuilder and Google SketchUp. Future release will also incorporate gbXML and IFC format data importing features so that CHAMPS-Multizone can import building designs from various types of commercial software that have gbXML and/or IFC compatibility.

Another feature of CHAMPS-Multizone is to communicate with Virtual Building database (Feng et al. 2008), which stores static building geometry and HVAC data as well as sensors' measurement data. Virtual Building collects various real-time measurement data including local climate conditions, indoor air quality, and pressure difference across the building envelope. Integrating with real-time monitoring data, CHAMPS-Multizone can also be used to simulate building operation in near-real time to validate real building performance, conduct systems diagnostic and fault detection, study advanced building control strategy and perform other building systems research and performance analysis.

User interface:

CHAMPS-Multizone uses MS VC++ and QT C++ as main development environment and implementation language. The user interface is developed in the framework of VC++ with QT integration. CHAMPS-Multizone's user-interface can display 3D building geometry and allow users to interact with building itself by selecting building components and set data as Figure 5 shows. The "Project Tree" represents the building system in a hierarchical structure to model

the relationship of building, floor, zone, wall, window, door, and crack opening (Figure 6). It allows users to easily select the zone to enter the required input data or display the simulation results. The "Library Tree" contains necessary user library such as climate conditions, zone conditions, HVAC systems, building construction assemblies etc. The central view displays a 3-D building geometry of the building under the option of showing the whole building or selected zone details. Zone data are displayed and entered in the "Zone Editing Window", which corresponds to the zone selected in the "Project Tree" and indicated in the geometry view. Separate dialogs window such as "HVAC Dialog" can be displayed for entering data regarding the HVAC system.

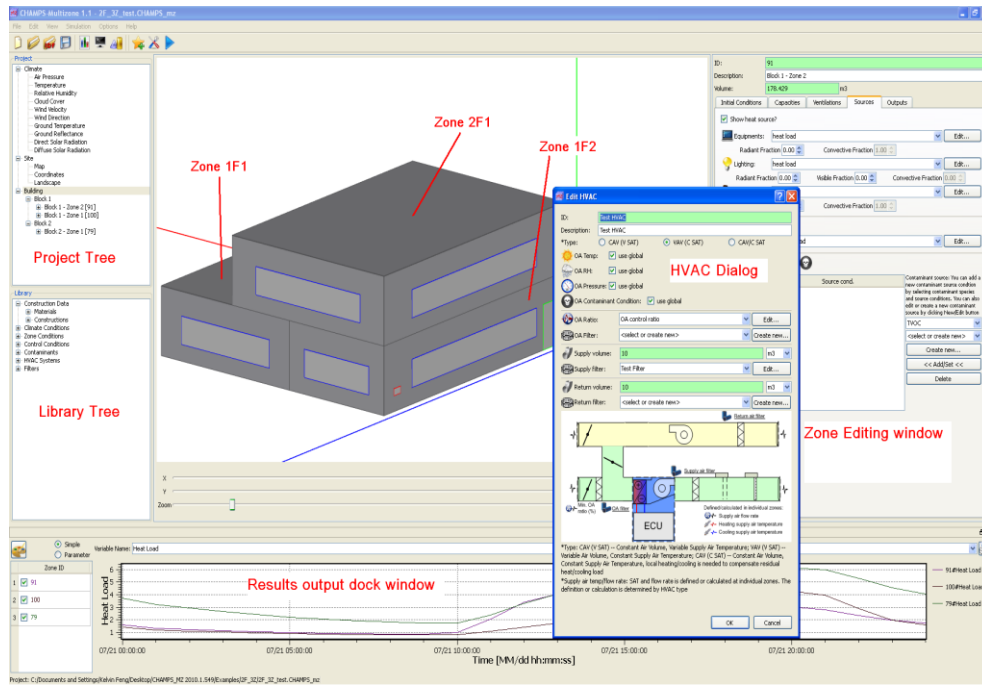

Figure 5 Graphical user interface

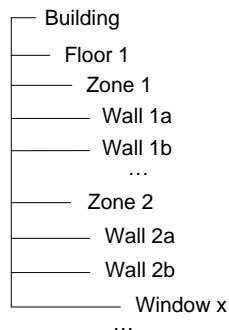

Figure 6 CHAMPS-Multizone project tree structure

RESULTS & DISCUSSION

Model Verifications

CHAMPS-Multizone has been tested by comparing simulation results with other well-established building simulation programs.

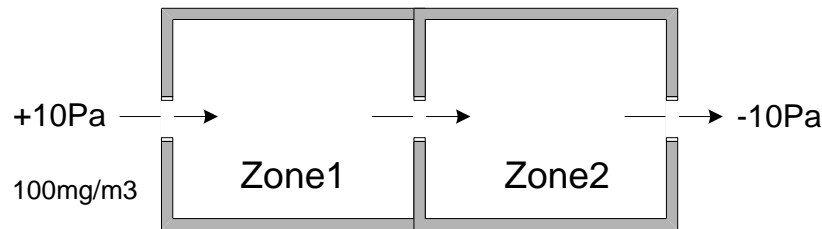

Figure 7 Two zone contaminant airflow test floor plan view

The first case tests CHAMPS- Multizone air-flow simulation and compare with the results from CONTAM. A connected two zones case with an opening in the partition wall is setup. Both zones are connected with ambient air via small openings as shown in Figure 7. Ambient air has contaminant TVOC concentration 100 mg/m³. Wind flow causes zone1's opening subject to +10 pa pressure filed; while zone2's opening is at the leeward side and connected with -10 pa pressure filed. The wind brings ambient air flow into zone1 then, across the opening in the partition, into zone2 and then goes out. The TVOC concentration in two zones is plotted in Figure 9 (a). The contaminant concentration is built up by wind driven airflow. At first, zone1's concentration starts to increase then the airflow between zone1 and zone2 introduces contaminant into zone2 and make zone2's contaminant concentration increase. It is found that CHAMPS-Multizone's results match very well those simulated by CONTAM (error within 2%).

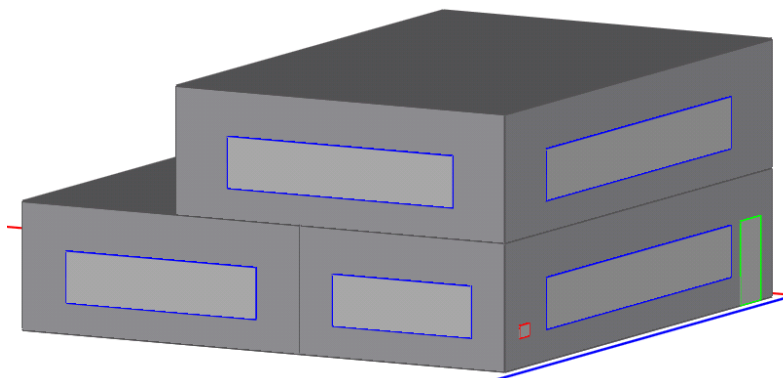

Figure 8 A two-floor, three-zone test case building

The second test is to compare CHAMPS-Multizone energy simulation accuracy by simulating the same building case. The building geometry is shown in Figure 8. It has two stories with two zones in the first floor and one zone on the second floor. A typical Light Weight Construction is used for the building envelope (see Table 3 of Appendix for details). Zone1 (West zone)'s heat load in a summer design day is plotted and very good match is found between CHAMPS-Multizone and EnergyPlus results [Figure 9 (b)]².

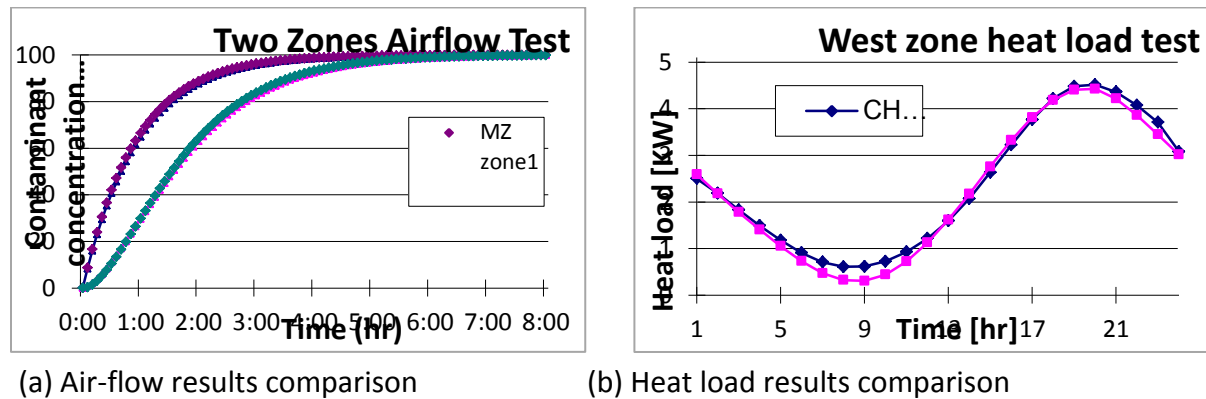

Figure 9 IAQ and energy simulation benchmarking

To further validate CHAMPS-Multizone's energy simulation accuracy, several ASHRAE 140-2007 standard cases (ANSI/ASHRAE 2007) are used and compared with EnergyPlus simulation. Since CHAMPS-Multizone has simple HVAC air loop model, the validation study is only made by applying ASHRAE 140-2007 building envelope cases especially Case 600 for low mass envelope building and Case 900 for high mass envelope building. The validation simulation cases are listed in Table 1.

² The small error at low heat load at morning time is potentially caused by: 1) the variant from solar radiation model output; 2) the different solving methods CHAMPS-Multizone and EnergyPlus use to solve long wave radiation. For details, please see EnergyPlus (2008).

Table 1 ASHRAE 140-2007 validation case list

Case name	Description
600 w/o window	low mass envelope w/o windows on South side wall
600 South Windows	low mass envelope w/ windows on South side wall
620 East&West windows	low mass envelope w/ windows on East & West walls
900 w/o window	high mass envelope w/o windows on South side wall
900 South Windows	high mass envelope w/ windows on South side wall
920 East&West windows	high mass envelope w/ windows on East & West walls
600FF w/o window	low mass envelope w/o windows free floating temperature
600FF South Windows	low mass envelope w/ windows free floating temperature
900FF w/o window	high mass envelope w/o windows free floating temperature
900FF South Windows	high mass envelope w/ windows free floating temperature

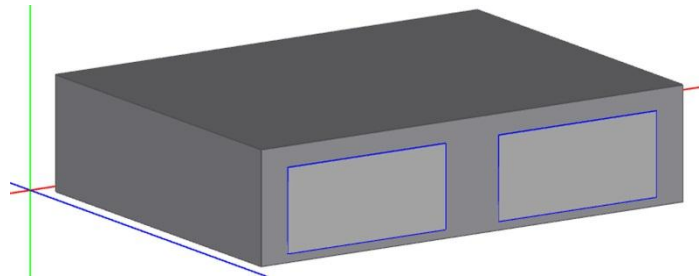
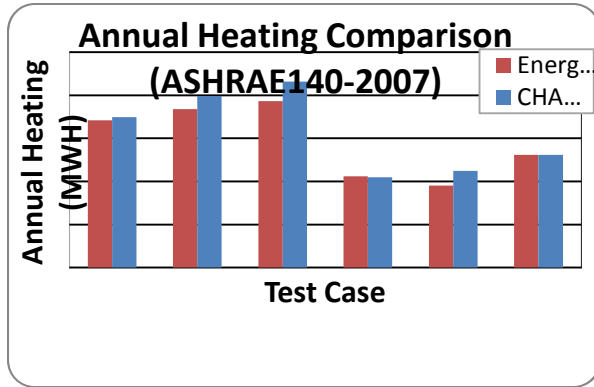
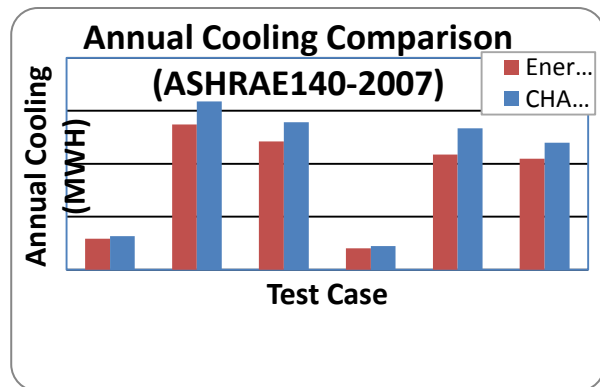

Figure 10 Base building (Case 600 & Case 900) - isometric view of Southwest corner with windows on South wall in CHAMPS-Multizone

Test case building is illustrated in Figure 10. Detailed case setup can be found in this paper's appendix. To accommodate CHAMPS-Multizone simulation needs, all cases room thermostat temperature setpoint is 22 °C for the whole year. And to evaluate window's influence, for each 600 and 900 series case, another case without window is created. For free floating room temperature cases, we use the same building geometry as Case 600 and Case 900 have for conditioned space test. Since CHAMPS-Multizone does not provide weather file converter, a Central NY weather file is created by converting CHAMPS-Multizone weather file format to EnergyPlus weather file (EPW). All other case settings are exactly the same with ASHRAE 140-2007 standard.



a) Annual heating energy comparison



b) Annual cooling energy comparison

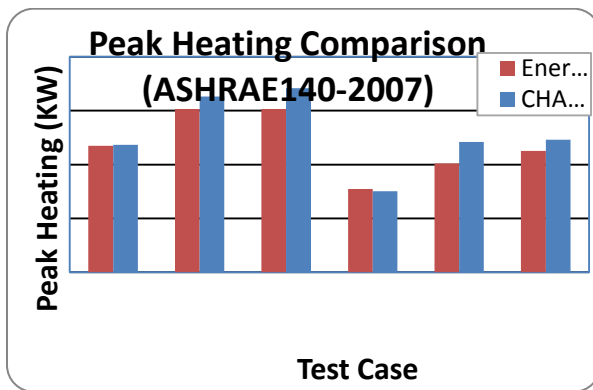

c) Peak heating rate comparison

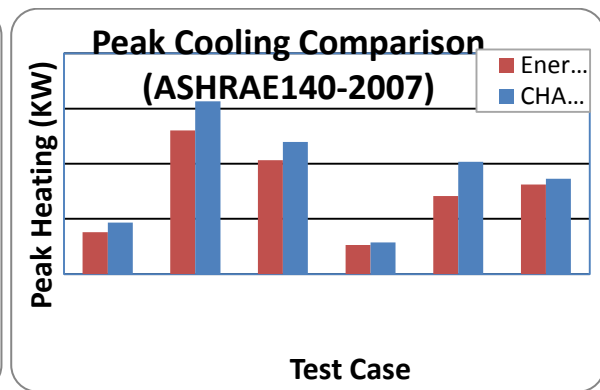

d) Peak cooling energy comparison

Figure 11 MZ and EnergyPluse ASHRAE 140-2007 conditioned energy comparison

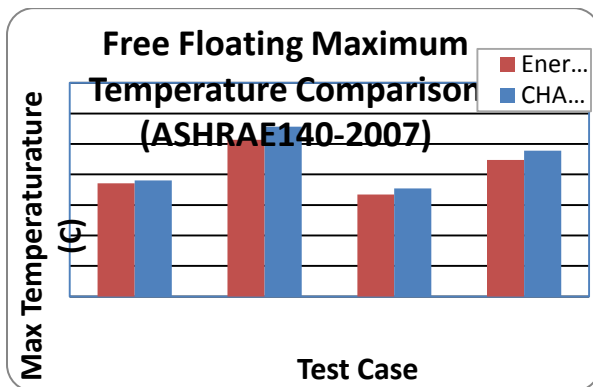

a) Free floating max temperature comparison

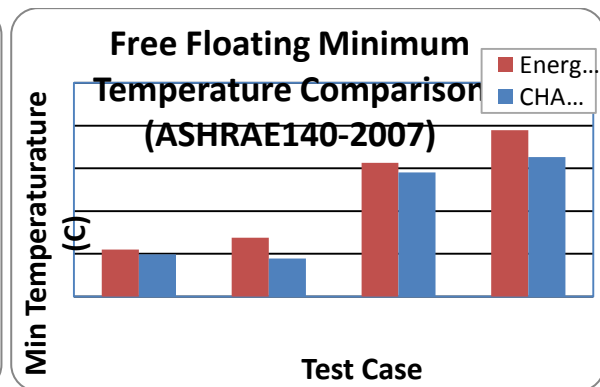

b) Free floating min temperature comparison

Figure 12 MZ and EnergyPluse ASHRAE 140-2007 free floating case comparison

The simulation results are shown in Figure 11 for conditioned building energy comparison and Figure 12 for unconditioned free floating room temperature comparison.

It can be found that CHAMPS-Multizone gives very similar annual heating and cooling energy and peak heating and cooling rate results compared with EnergyPlus. The results match better at w/o window cases. In w/ windows cases, CHAMPS-Multizone tends to give slightly higher prediction of energy consumption compared with EnergyPlus. Similar results can be found in free floating temperature test cases. The main reason is that CHAMPS-Multizone models windows in different ways from EnergyPlus. CHAMPS-Multizone adopts the empirical window model which gives the conduction heat loss/gain through window as a temperature driven phenomenon by multiplying the indoor and outdoor temperature difference by window's U value; while the radiation heat gain is calculated by applying window system's SHGC. The total window system heat gain is given by Equation (9) (ASHRAE 2005):

$$Q = U A_{pf}(T_{out} - T_{in}) + (SHGC)A_{pf}E_t \quad (9)$$

Where U is window's U value, A_{of} is window projection area; E_t is incidental solar irradiance. On the contrast, EnergyPlus uses detailed window pane balance method (EnergyPlus development team 2010). However, the difference is within the acceptable range (the maximum difference between CHAMPS-Multizone and EnergyPlus is 12% for peak load cases, and 3 °C for free floating temperature case) when contrasting EnergyPlus with other simulation software ASHRAE 140-2007 test results, in which the maximum difference between the other models and EnergyPlus is 15% of peak load and 5 °C for free floating cases (Henninger 2010).

Case study 1

A combined energy and IAQ simulation case, with the same building geometry in Figure 8 (for detailed case setup, simulation parameters can be found in Appendix 3), is created using CHAMPS-Multizone. One Air Handling Unit is setup with a VAV system. For cooling, the supply air temperature is set at 14 C with variable supply air flow rate to compensate zone heat load. One zone (2F1) had constant TVOC emission at 0.1 mg/s. The Outdoor Air (OA) is clean and had no contaminant. The simulation uses ventilation via the AHU to bring fresh air into building to reduce indoor pollutant concentration. One summer day simulation is conducted and results are shown in Figures 13 and 14.

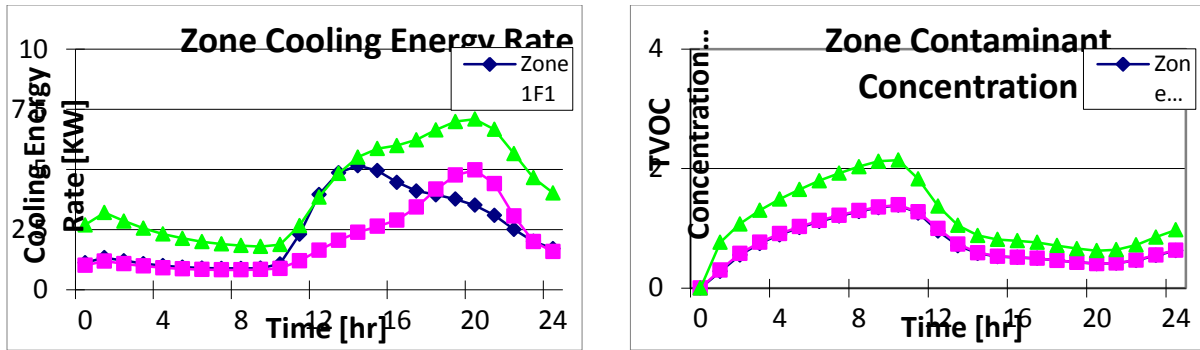

(a) Cooling energy input (b) Pollutant concentrations

Figure 13 Case building energy and IAQ performance (20% OA)

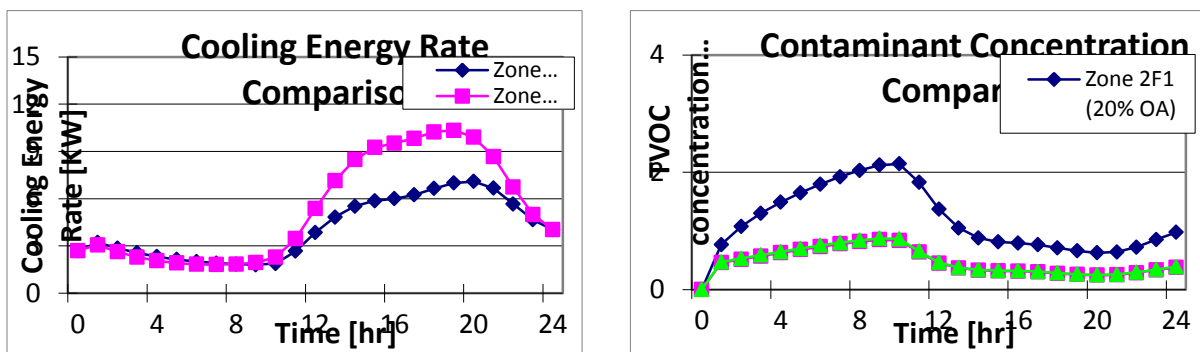

(a) Cooling energy rate comparison (b) Pollutant concentrations comparison

Figure 14 Case building combined energy and IAQ simulation under different IAQ control strategies

For this case, a general energy and IAQ simulation results for three (3) zones are shown in Figure 13(a) and 13(b) respectively. Increasing OA ratio from 20% to 80% can dilute indoor pollutants concentration but gives higher energy penalty (Figure 14a). Alternatively, to keep the same OA ratio but use air cleaner to filter pollutant from return air can also achieve better IAQ (Figure 14b) but would not have energy penalty for conditioning extra hot OA, neglecting the energy consumption associated with the air cleaning process. The results illustrate the ability of the program in analyzing the trade-off between energy saving and IAQ improvement strategies.

Case Study 2

To further demonstrate CHAMPS-Multizone for combined Energy and IAQ simulation. A real building located at Central NY is setup to simulate its indoor air quality and energy performance. Finally, the building performance simulation results are compared with real time Virtual Building performance monitoring system to verify simulation's accuracy.

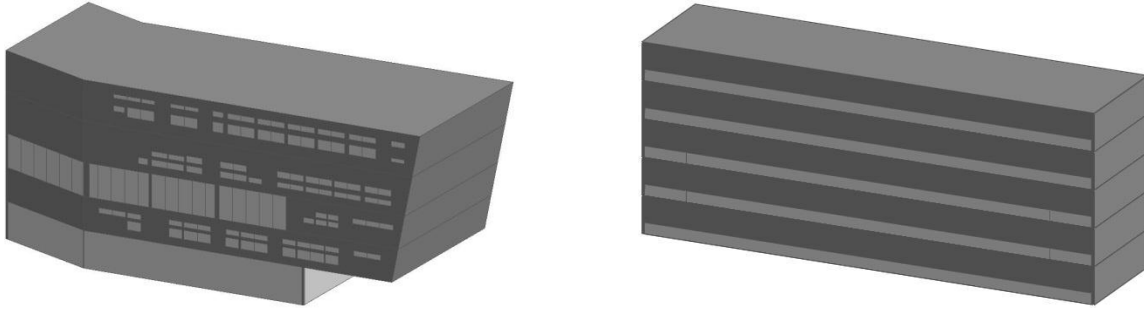

Figure 15 Case study 2 building - isometric view of Northwest corner in CHAMPS-Multizone (left, as-built model; right, simplified model)

The building is a five-storey office building (Figure 15). In the simulation, its geometry is approximately modelled as a rectangular shape with length of 54.5 m and width of 13.6m. The Window to Wall Ratio (WWR) of facade is South side 100%, North 30%, West 0% and East 60%. The building uses Dedicated Outdoor Air (DOA) air handling unit and radiant panels for handling most (up to about 80%) of the heating and cooling loads. The water loop uses Ground Source Heat Pump (GSHP) and boilers if additional heating is needed in winter time. Detailed building parameters can be found in Appendix 4.

Since this is a new office building, the furniture we have in this building can emit contaminants such as VOCs. The 2nd and 3rd floor of building has VOCs emission sources, while other floors do not have direct VOCs emission. Here we try to evaluate different ventilation systems and impact on building's energy and IAQ performance. DOA and traditional mixing air ventilation systems are studied in this case. The DOA system uses 100% OA and enthalpy recovery. Since the case building is a green building, to comply with LEED (2005) standard, the DOA system is designed to have additional OA ventilation rate compared with traditional mixed air system to provide better indoor air quality. The building's air conditioning system is turned on at 6:00 am and shut down at 5:00 pm during working days. During non-working hours and weekend, the fan is kept operating but the OA damper is turned off and valves are shut down, and air is fully recirculated.

Figure 16 (a) shows whole building heating energy rate when using DOA system and 20% OA mixing air system. It can be found that mixing air system can achieve similar energy consumption compared with DOA system. For indoor air quality, as Figure 16 (b) shows, TVOC concentration in one office room increases during non-work hours because of recirculating return air under both systems. However, during work time, when applying mixing air system, the TVOC concentration is higher than the concentration of using DOA system, because it recirculates return air as well as indoor pollutants, and mixes it with supply fresh air. It can be

concluded that traditional mixing air system, even though it can achieve similar building energy performance by reducing OA ratio, it is not effective in diluting and eliminating indoor pollutants when compared with DOA system.

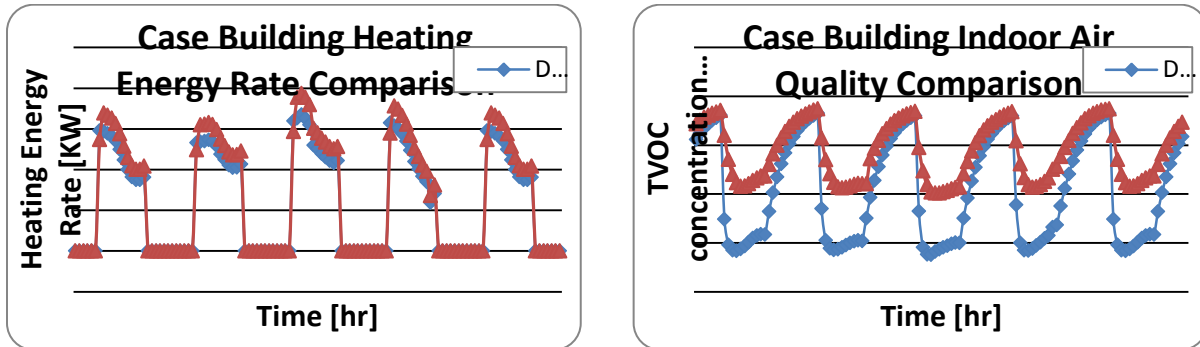

(a) Heating energy rate comparison (b) Pollutant concentrations comparison

Figure 16 Case building combined energy and IAQ simulation under ventilation systems

Furthermore, to validate our simulation models' accuracy, we compare CHAMPS-Multizone's simulation results with Virtual Building real time building performance monitoring of a 5-storey, 40,000 ft² floor area building (See Appendix for details). CHAMPS-Multizone generally gives good prediction on building's heating energy rate. Since the case building's heating system experience on-off operation, the monitored heating energy rate fluctuates with time. However, the trends predicted by CHAMPS-Multizone agree well with Virtual Building measurement results.

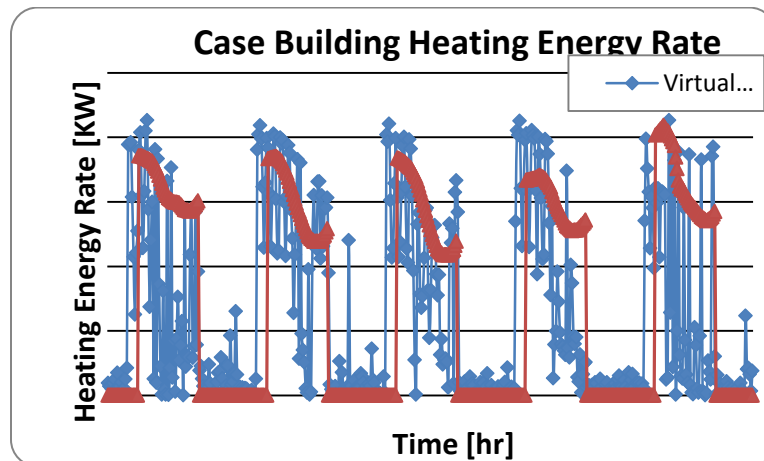
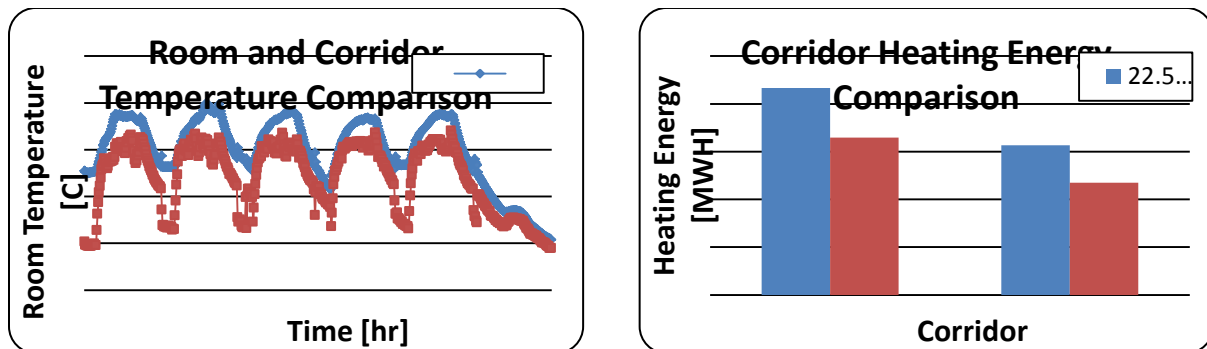

Figure 17 Case building heating energy rate comparison between CHAMPS-Multizone and Virtual Building monitoring

Another study of combining Virtual Building and CHAMPS-Multizone is carried out by analyzing the impact of controlling the corridor zones and work space zones (offices and conference rooms) at different temperature setpoints on energy consumption. It is found that, through Virtual Building monitoring, the corridors of case building are controlled at different temperature compared with office rooms. In winter, for instance, the corridor's setpoint is 21 °C and the office room setpoint is 22.5 °C as Figure 18 a) shows. The lower setpoint in corridors can reduce heating energy consumption at winter time, because corridors, which are not frequently occupied, can have relatively lower thermal comfort requirements compared with office rooms. CHAMPS-Multizone simulates the case building by comparing two scenarios: corridors setpoint at 21 °C and 22.5 °C. The heating energy of two corridors is given for one winter month (December) simulation by Figure 18 b). It can be found that lower setpoint in corridors can save corridor heating energy consumption about 20% in one winter month.



(a) Corridor and office room temperature (b) Corridor heating energy comparison

Figure 18 Case building room temperature and corridor heating energy analysis

CONCLUSIONS

CHAMPS-Multizone is a new simulation program which can simulate combined heat, air, moisture, and pollutant transport process in whole building systems. The ability of simulating energy and IAQ building performance at the same time makes this program suitable to conduct comprehensive building performance analysis. In combination with Virtual Building monitoring system, CHAMPS-Multizone can compare simulation results with real-time building performance and help researchers better validate models' accuracy. To facilitate designers to use CHAMPS-Multizone to study building designs and its performance, CHAMPS-Multizone includes special modules which can import design data from design platform, such as Google SketchUp and Revit, via IFC or IDF format. Potential applications of this program include combined building energy and IAQ performance analysis, architectural design and building systems performance analysis, real-time building performance simulation, control and fault detection.

Besides existing functions, several research and development work are going on to enhance the data interoperability of the software, incorporate more detailed HVAC systems simulation via coupling with EnergyPlus and more detailed room simulation via coupling with a sub-zonal room model, and coupling with a building design advisory user interface module (called "virtual design studio") to assist architects in evaluating green building technologies at various design stages.

REFERENCES

- ANSI/ASHRAE 2007, Standard 140-2007, Standard Method of Test for the Evaluation of Building Energy Analysis Computer Programs, American Society of Heating, Refrigerating and Air-Conditioning Engineers, Atlanta, GA.
- ASHRAE 2005, ASHRAE Handbook Fundamentals SI Edition. American Society of Heating, Refrigerating and Air-Conditioning Engineers, Atlanta, GA.
- CHAMPS-BES 2009, a Combined Heat Air Moisture and Pollutant Transport model for Building Envelope System, champs.syr.edu.
- CHAMPS Webpage 2009, <http://champs.syr.edu>.
- Collier A., et al. 2006, User Documentation for KINSOL v2.5.0, Center for Applied Scientific Computing, Lawrence Livermore National Laboratory.
- Crawley, D.B. 2001, "EnergyPlus: creating a new-generation building energy simulation program", *Energy and Buildings* 33 (2001) 319-331, ELSEVIER.
- Crawley, D.B. 2008, "Contrasting the Capabilities of Building Energy Performance Simulation Programs", *Building and Environment* 43 (2008) 661-673, ELSEVIER.
- DesignBuilder 2009, <http://www.designbuilder.co.uk>.
- Duffie, J. A. and Beckman W. A. 1980, *Solar Engineering of Thermal Processes*, Wiley-Interscience, New York, p.775.
- EnergyPlus development team 2010, *EnergyPlus Engineering Reference - The Reference to EnergyPlus Calculations*, EnergyPlus Version 6.0.
- Feng, W. and Zhang J.S. 2009, Indoor and Urban Environmental Monitoring using "Virtual Building" Approach, *Healthy Building 2009 International Conference*, Syracuse NY.
- Google SketchUp 2009, <http://sketchup.google.com>.
- Grunewald, J. 2009, Review of Solar Radiation Models, CHAMPS workshop, Syracuse University, Syracuse, NY.
- Gu, L. 2010, Personal communication.
- Henninger, R.H. and Witte, M.J. 2010, *EnergyPlus Testing with Building Thermal Envelope and Fabric Load Tests from ANSI/ASHRAE Standard 140-2007*, Report to Department of Energy.
- Hindmarsh, A. and Serban, R. 2006, User Documentation for CVODE v2.5.0, Center for Applied Scientific Computing, Lawrence Livermore National Laboratory.
- Hottel and Sarofim 1967, *Radiative Transfer*, Chapter 3, McGraw Hill.
- Iu, I. 2009, Personal Communication.
- Nicolai, A. 2007, "Modeling and Numerical Simulation of Salt Transport and Phase Transitions in Unsaturated Porous Building Materials", PH.D dissertation, Syracuse University.
- Nicolai, A. Grunewald, J. and Zhang, J.S. 2007, Recent improvements in HAM simulation tools: Delphin 5/CHAMPS. 12th International Building Physics Conference. Dresden, Germany. March 28-30.

Nicolai, A. 2010, Personal communication.

Perez, R., et al. 1990, *Modeling Daylight Availability and Irradiance Components from Direct and Global Irradiance*, *Solar Energy*, 44(5), p. 271-289.

Spencer, J.W. 1971, *Fourier series representation of the position of the sun*. *Search*, Vol. 2, No. 5, p. 172.

USGBC 2005, LEED for New Construction & Major Renovations, U.S. Green Building Council, Version 2.2.

Walton, G. and Stuart D. 2006, CONTAM 2.4 User Guide and Program Documentation, National Institute of Standards and Technology, Gaithersburg, MD.

Zhang, J.S. 2005, "Combined Heat, Air, Moisture, and Pollutants Transport in Building Environmental Systems", *JSME International Journal, Series B*, Vol.48, No.2.

APPENDIX

1. CHAMPS-Multizone and CONTAM airflow test case parameters

Table 2 CHAMPS-Multizone and CONTAM Airflow Test Parameters

Parameter	Setting
Zone size	(see details in test case descriptions)
outside VOC concentration	100 mg/m ³ (6.24*10 ⁻⁶ lb/ft ³)
Initial zone VOC concentration	0 mg/m ³ , for all zones
zone emission rate	0 mg/m ³ , for all zones
Zone temperature	23 C (73 F) constant
Zone RH	50%
Wind pressure	+10 Pa (0.04 inch WC) for windward side, -10 Pa for leeward side
Flow path1 (connected to exterior)	k = 0.02, n = 0.5
Flow path2 (inter-zonal)	k = 0.01, n = 0.5

2. CHAMPS-Multizone and EnergyPlus zone heat load test case parameters

Table 3a Zone heat load test case lightweight wall assembly -- SI units

Layer	Material	k (W/m-K)	Thickness (m)	R (m ² -K/W)	Density (kg/m ³)	Cp (J/kg-K)
Inside layer	Gypsum board	0.160	0.019		800	1090
Layer 2	Air space resistance			0.150		
Layer 3	Insulation board	0.030	0.0508		43	1210
Layer 4	Metal Surface	45.280	0.001		7824	500

Table 3b Zone heat load test case lightweight wall assembly -- IP units

Layer	Material	k (Btu-in/hr-ft-F)	Thickness (ft)	R (ft ² -hr/Btu)	Density (lb/ft ³)	Cp (Btu/lb-F)
Inside layer	Gypsum board	1.110	0.0623		49.92	0.260
Layer 2	Air space resistance			0.852		
Layer 3	Insulation board	0.208	0.1666		2.68	0.289
Layer 4	Metal Surface	314.017	0.00328		488.22	0.119

For detailed building geometry information, please refer to Appendix 4

3. ASHRAE 140-2007 test case building

1) Building geometry

The basic test building (Figure 10) is a rectangular single zone (8 m wide × 6 m long × 2.7 m high) with no interior partitions and two 6 m² (3 m high × 2 m long) windows on the south exposure. Both Case 600 and Case 900 share the same building geometry. For Case 620 and Case 920, the only difference from Case 600 and 900 in geometry is that the two windows are placed on the East and West wall respectively with the same window geometry. For further details refer to Section 5.2.1 of ANSI/ASHRAE Standard 140-2007.

2) Building construction materials

Table 4a Case 600 series lightweight wall assembly – SI units

Layer	Material	k (W/m-K)	Thickness (m)	U (W/m ² -K)	R (m ² -K/W)	Density (kg/m ³)	Cp (J/kg-K)
Inside layer	Plasterboard	0.160	0.012	13.333	0.075	950	840
Layer 2	Fiberglass Quilt	0.040	0.066	0.606	1.650	12	840
Layer 3	Wood Siding	0.140	0.009	15.556	0.064	530	900

Table 4b Case 600 series lightweight wall assembly – IP units

Layer	Material	k (Btu-in/hr-ft-F)	Thickness (ft)	U (Btu/hr-ft ² -F)	R (ft ² -hr/Btu)	Density (lb/ft ³)	Cp (Btu/lb-F)
Inside layer	Plasterboard	1.11	0.391	2.347	0.426	59.28	0.2
Layer 2	Fiberglass Quilt	0.277	0.216	0.107	9.367	0.749	0.2
Layer 3	Wood Siding	0.971	0.03	2.738	0.363	33.07	0.215

Table 5a Case 600 series lightweight roof assembly – SI units

Layer	Material	k (W/m-K)	Thickness (m)	U (W/m ² -K)	R (m ² -K/W)	Density (kg/m ³)	Cp (J/kg-K)
Inside layer	Plasterboard	0.160	0.010	16.000	0.063	950	840
Layer 2	Fiberglass Quilt	0.040	0.112	0.358	2.794	12	840
Layer 3	Roof Deck	0.140	0.019	7.368	0.136	530	900

Table 5b Case 600 series lightweight roof assembly – IP units

Layer	Material	k (Btu-in/hr-ft-F)	Thickness (ft)	U (Btu/hr-ft ² -F)	R (ft ² -hr/Btu)	Density (lb/ft ³)	Cp (Btu/lb-F)
Inside layer	Plasterboard	1.11	0.0328	2.816	0.358	59.28	0.2
Layer 2	Fiberglass Quilt	0.277	0.367	0.063	15.86	0.749	0.2
Layer 3	Roof Deck	0.971	0.0623	1.297	0.772	33.07	0.215

Table 6a Case 600 series lightweight floor assembly – SI units

Layer	Material	k (W/m-K)	Thickness (m)	U (W/m ² -K)	R (m ² -K/W)	Density (kg/m ³)	Cp (J/kg-K)
Inside layer	Timber Flooring	0.140	0.025	5.600	0.179	650	1200
Layer 2	Insulation	0.040	1.003	0.040	25.075		

Table 6b Case 600 series lightweight floor assembly – IP units

Layer	Material	k (Btu-in/hr-ft-F)	Thickness (ft)	U (Btu/hr-ft ² -F)	R (ft ² -hr/Btu)	Density (lb/ft ³)	Cp (Btu/lb-F)
Inside layer	Timber Flooring	0.971	0.082	0.984	1.016	40.56	0.287
Layer 2	Insulation	0.277	3.29	0.007	142.346		

Table 7a Case 900 series heavyweight wall assembly – SI units

Layer	Material	k (W/m-K)	Thickness (m)	U (W/m ² -K)	R (m ² -K/W)	Density (kg/m ³)	Cp (J/kg-K)
Inside layer	Concrete Block	0.510	0.100	5.100	0.196	1400	1000
Layer 2	Foam Insulation	0.040	0.0615	0.651	1.537	10	1400
Layer 3	Wood Siding	0.140	0.009	15.556	0.064	530	900

Table 7b Case 900 series heavyweight wall assembly – PI units

Layer	Material	k (Btu-in/hr-ft-F)	Thickness (ft)	U (Btu/hr-ft ² -F)	R (ft ² -hr/Btu)	Density (lb/ft ³)	Cp (Btu/lb-F)
Inside layer	Concrete Block	3.537	0.328	0.899	1.113	87.36	0.239
Layer 2	Foam Insulation	0.277	0.2	0.115	8.725	0.624	0.334
Layer 3	Wood Siding	0.971	0.03	2.752	0.363	33.07	0.215

Table 8a Case 900 series heavyweight floor assembly – SI units

Layer	Material	k (W/m-K)	Thickness (m)	U (W/m ² -K)	R (m ² -K/W)	Density (kg/m ³)	Cp (J/kg-K)
Inside Layer	Concrete Slab	1.130	0.080	14.125	0.071	1400	1000
Layer 2	Insulation	0.040	1.007	0.040	25.075		

Table 8b Case 900 series heavyweight floor assembly – PI units

Layer	Material	k (Btu-in/hr-ft-F)	Thickness (ft)	U (Btu/hr-ft ² -F)	R (ft ² -hr/Btu)	Density (lb/ft ³)	Cp (Btu/lb-F)
Inside Layer	Concrete Slab	7.84	0.2624	2.481	0.403	87.36	0.239
Layer 2	Insulation	0.277	3.3	0.007	142.351		

Table 9 Case 600, 900 series window pan material properties

Window Property	Data
Glass Name	Glass Type 1
Optical Data Type	Spectral Average
Window Glass Spectral Data Set Name	
Thickness	0.003175 m (1/8 in)
Solar Transmittance at Normal Incidence	0.86156
Front Side Solar Reflectance at Normal Incidence	0.07846
Back Side Solar Reflectance at Normal Incidence	0.07846
Visible Transmittance at Normal Incidence	0.91325
Front Side Visible Reflectance at Normal Incidence	0.082
Back Side Visible Reflectance at Normal Incidence	0.082
Infrared Transmittance at Normal Incidence	0
Front Side Infrared Hemispherical Emissivity	0.84
Back Side Infrared Hemispherical Emissivity	0.84
Conductivity	1.06 W/m-K (7.351 Btu-in/hr-ft-F)

Table 10 Case 600, 900 series window assembly

Construction	Name
Name	Double Pane Window
Outside Layer	Glass Type 1,
Layer 2	Air Space Resistance
Layer 3	Glass Type 1

3) Other parameter settings

Table 11 Case 600, 900 series building parameters

Parameter	Setting
Infiltration	0.5 ACH for all test cases
Internal Heat Source	200 W (682.36 Btu/hr) constant, convective fraction 0.4 and radiant fraction 0.6
Setpoint	22 C (71.6 F) constant (for conditioned case only)
Ground Temperature	10 C (50 F) constant
Ground reflectance	0.2 constant

4. CHAMPS-Multizone case study 1 building parameters

1) Building geometry

The case building can be found in Figure 8 for isometric view of Southeast corner. The first floor building is square shape with dimension 10 m (32.8 ft) wide × 10 m (32.8 ft) long × 3.5 m (11.48 ft) high. The first floor is divided into East and West two zones with West (big) zone 6 m (19.68 ft) wide and East (small) zone 4 m (13.12 ft) wide. The West zone has one window (3.8 m (12.64

ft) wide × 1.5 m (4.92 ft) high) on its South and North walls respectively, while for East zone a smaller window (2.8 m (9.18 ft) wide × 1.5 m (4.92 ft) high) also on its South and North walls. There are windows (6.5 m (21.32 ft) wide × 1.5 m (4.92 ft) high) at the East and West side exterior walls of building. The 2nd floor is a single zone with dimension same with West zone in the 1st floor (6 m wide (19.68 ft) × 10 m (32.8 ft) long × 3.5 (11.48 ft) m high). Also it has the window size with 1st floor West zone.

2) Building construction materials,

Typically lightweight construction is used for this case building. The construction (wall, roof, floor and window) material properties are the same with ASHRAE 140-2007 Case 600.

3) Other parameter settings,

Table 12 case study building other parameters

Parameter	Setting
Infiltration	0 ACH for all zones
Internal Heat Source	0 W for all zones
Setpoint	23 C (73.4 F) constant
Ground Temperature	14 C (57.2 F) constant
Ground reflectance	0.2 constant
Initial pollutant concentration	0 mg/m ³ for all zones
pollutant emission rate	1 mg/m ³ (6.24*10 ⁻⁸ lb/ft ³) for the zone at 2nd floor, 0 mg/m ³ for 1st floor zones
HVAC supply, return zone	10 m ³ (353.1 ft ³) volume for both supply and return duct
HVAC supply air temperature	14 C (57.2 F) for VAV system
HVAC filter (only in filter case)	efficiency 0.7, mounted at return air main duct
OA ratio	20% and 80% OA

5. CHAMPS-Multizone case study 2

1) Building geometry

The building is an office building located at Central NY climate conditions. The building has five storeys with rectangular shape of dimension 54.5 m (178.76 ft) long × 13.6 m (44.61 ft) wide × 23 m (75.44 ft) high. The isotropic view of building geometry can be found in Figure 15. The 2nd and 3rd floor have corridor on the South and North side of each floor. Each corridor's is 2 m (6.56 ft) wide and 43 m (141.01 ft) long.

2) Building Envelope

Table 13a Case study 2 building exterior wall assembly – SI units

Layer	Material	k (W/m-K)	Thickness (m)	R (m ² -K/W)	Density (kg/m ³)	Cp (J/kg-K)
Inside layer	Gypsum Board	0.250	0.0159		900	1000
Layer 2	Air Gap		0.152	0.160		
Layer 3	Polyurethane	0.050	0.051		70	1500
Layer 4	Firberboard	0.06	0.0159		300	1000
Layer 5	EPS	0.04	0.0508		15	1400
Layer 6	Air Gap		0.019	0.15		
Layer 7	Metallic Cladding	0.29	0.0079		1250	1000

Table 13b Case study 2 building exterior wall assembly – IP units

Layer	Material	k (Btu-in/hr-ft-F)	Thickness (ft)	R (ft ² -F-hr/Btu)	Density (lb/ft ³)	Cp (Btu/lb-F)
Inside layer	Gypsum Board	1.734	0.052		56.16	0.239
Layer 2	Air Gap		0.5	0.908		
Layer 3	Polyurethane	0.347	0.167		4.37	0.358
Layer 4	Firberboard	0.416	0.052		18.72	0.239
Layer 5	EPS	0.277	0.167		0.936	0.334
Layer 6	Air Gap		0.062	0.851		
Layer 7	Metallic Cladding	2.011	0.026		78	0.239

Table 14 Case study 2 building Window Assembly

Layer	Name	Thickness	Description
Inside Layer	Low E clear glass	6 mm (1/4 in)	Low E coating (e2=0.1)
Layer 2	Argon	13 mm (1/2 in)	
Layer 3	Generic clear glass	6 mm (1/4 in)	

Table 15 Case study 2 building Window to Wall Ratio (WWR)

Façade Side	Window to Wall Ratio (WWR)
South	100%
North	30%
West	0%
East	60%

3) Ventilation, air change, controls and other parameter settings

The HVAC air system of case building 2 uses 100% OA and enthalpy recovery wheel and desiccant wheel for heat and moisture recovery. The water loop of case building 2 is designed by using ground source heat pump (GSHP) for heating and cooling. Should additional heating is needed, two boilers are also available. Since CHAMPS-Multizone does not model HVAC water

loop, only the heating or cooling rate delivered from water loop to air loop is calculated in CHASMP5-Multizone and compared with Virtual Building monitoring data. For air system modelling, Virtual Building's measurement data is utilized to understand how energy is recovered when passing through enthalpy recovery wheel and eventually use the recovered air properties in CHAMPS-Multizone simulation. The radiant panel in each zone is simulated as internal heat/cool source in CHAMPS-Multizone without detailed modelling the water loop.

Table 16 Case study 2 other simulation parameters

Parameter	Setting
Air Change	0.2 ACH
HVAC	DOA and 20% mixing air system
Zone setpoint	22.5 C (72.5 F)
HVAC operations	6:00am ~ 5:00pm ON; other time and weekend OFF
Fan operation	recirculate 100% return at non-work hours
VOC source	2F zones 2mg/m ³ ; 3F zones 1 mg/m ³ (6.24*10 ⁻⁸ lb/ft ³)
Heat source	10 W/m ² (0.317 Btu/hr-ft ²)