

Lawrence Berkeley National Laboratory

Recent Work

Title

LIGHT ISOTOPES OF BERKELIUM AND CALIFORNIUM

Permalink

<https://escholarship.org/uc/item/1fm7b1fp>

Author

Chetham-Strode, Alfred

Publication Date

1956-06-26

UNIVERSITY OF
CALIFORNIA

*Radiation
Laboratory*

LIGHT ISOTOPES OF BERKELIUM
AND CALIFORNIUM

TWO-WEEK LOAN COPY

*This is a Library Circulating Copy
which may be borrowed for two weeks.
For a personal retention copy, call
Tech. Info. Division, Ext. 5545*

DISCLAIMER

This document was prepared as an account of work sponsored by the United States Government. While this document is believed to contain correct information, neither the United States Government nor any agency thereof, nor the Regents of the University of California, nor any of their employees, makes any warranty, express or implied, or assumes any legal responsibility for the accuracy, completeness, or usefulness of any information, apparatus, product, or process disclosed, or represents that its use would not infringe privately owned rights. Reference herein to any specific commercial product, process, or service by its trade name, trademark, manufacturer, or otherwise, does not necessarily constitute or imply its endorsement, recommendation, or favoring by the United States Government or any agency thereof, or the Regents of the University of California. The views and opinions of authors expressed herein do not necessarily state or reflect those of the United States Government or any agency thereof or the Regents of the University of California.

UCRL-3322
Chemistry Distribution

UNIVERSITY OF CALIFORNIA
Radiation Laboratory
Berkeley, California
Contract No. W-7405-eng-48

LIGHT ISOTOPES OF BERKELIUM AND CALIFORNIUM

Alfred Chetham-Strode, Jr.

(Thesis)

June 26, 1956

Printed for the U. S. Atomic Energy Commission

LIGHT ISOTOPES OF BERKELIUM AND CALIFORNIUM

Contents

Abstract.....	4
I. Introduction.....	5
II. Production and Preparation of Target Materials.....	6
A. Production of Target Isotopes.....	6
1. Americium-241.....	6
2. Curium-242.....	7
3. Americium-243 and Curium-244.....	7
B. Target Preparation.....	13
1. Initial Separations.....	13
2. Final Isolation.....	14
3. Direct Evaporation.....	17
4. Vacuum Sublimation and Electrodeposition.....	18
III. Bombardment Techniques.....	20
A. Target Assemblies.....	20
1. "Microtarget" Assembly.....	20
2. Deflector Channel Probe.....	20
a. Range-energy relation for recoil nuclei.....	21
b. Angular distribution of recoil nuclei.....	23
c. Recoil collection efficiency.....	25
B. Bombardment Chemistry.....	25
1. General Procedures.....	25
2. Fast Electrodeposition.....	26
C. Instrumental Methods.....	29
IV. Excitation Functions.....	29
A. Experimental Methods.....	30
B. Excitation Functions.....	31
1. Helium Ions on Curium-244.....	31
2. Helium Ions on Americium-243.....	34
3. Helium Ions on Americium-241 and Curium-242.....	37
C. Summary of Results.....	37

V. Nuclear Properties of Berkelium and Californium Isotopes..	38
A. Berkelium Isotopes.....	38
1. Berkelium-243.....	38
2. Berkelium-244.....	43
3. Berkelium-245.....	46
4. Berkelium-246.....	52
5. Berkelium-247.....	56
6. Berkelium-248.....	62
7. Berkelium-249.....	65
B. Californium Isotopes.....	67
1. Californium-244.....	67
2. Californium-245.....	69
3. Californium-246.....	71
4. Californium-247.....	73
VI. Discussion of Results.....	77
A. Orbital Electron Capture in the Berkelium Isotopes....	77
B. Alpha Decay in the Odd-Mass Berkelium Isotopes.....	81
C. Decay Energies.....	84
Acknowledgments.....	87
List of Illustrations.....	88
List of Tables.....	90
References.....	91

LIGHT ISOTOPES OF BERKELIUM AND CALIFORNIUM

A. Chetham-Strode, Jr.

Radiation Laboratory
and
Department of Chemistry and Chemical Engineering
University of California, Berkeley, California

June 26, 1956

ABSTRACT

An experimental study has been made of the light isotopes of berkelium and californium. The new isotopes Bk^{244} , Bk^{247} , Bk^{248} , and Cf^{244} were identified and their properties studied.

Radiations from the berkelium isotopes of mass numbers 244 through 249 and of the californium isotopes of mass numbers 244 through 247 were investigated by nuclear spectroscopic and coincidence techniques. Decay schemes are suggested for several of these isotopes, and observed regularities in the decay patterns of analogous nuclides are discussed.

Further information is presented on the production of americium and curium target materials and the yields of berkelium and californium isotopes from the helium-ion bombardment of americium and curium.

I. INTRODUCTION

The initial attempts to synthesize transcurium elements were directed along two lines. One approach involved the bombardment of americium and curium with charged particles in the cyclotron, while the other involved the irradiation of plutonium with neutrons in a reactor, leading ultimately to a beta-emitting isotope of curium.

The first of these approaches was carried out successfully by Thompson, Ghiorso, and Seaborg^{1,2} in late 1949. The bombardment of Am^{241} with helium ions was shown to result in the formation of an isotope of the new element berkelium, the 4.6-hr Bk^{243} . Almost immediately thereafter a 45-min californium isotope, thought to be Cf^{244} , was found by Thompson, Street, Ghiorso, and Seaborg^{3,4} among the products of a similar bombardment of Cm^{242} . In the following three years some five additional isotopes of berkelium and californium were discovered; Bk^{245} and Bk^{246} through the helium-ion bombardments,^{5,6,7} and Cf^{246} , Cf^{247} and Cf^{248} by the bombardment of uranium with accelerated carbon nuclei.^{8,52}

In the latter part of 1953, the second of these approaches was successful. In addition to a number of heavy isotopes of americium and curium, several new isotopes of berkelium and californium were found in plutonium samples that had been subjected to the intense neutron flux of the Materials Testing Reactor.⁹ Further irradiations¹⁰ of these products and mass spectrographic studies¹¹ resulted in the identification of Bk^{249} , Bk^{250} , Cf^{249} , Cf^{250} , Cf^{251} , and Cf^{252} . More recent papers^{12,13} have reported Cf^{253} and Cf^{254} .

As a further result of the neutron irradiation program, some of the heavier americium and curium isotopes, notably Am^{243} and Cm^{244} , were produced in suitable purity and isolated in quantities sufficient for cyclotron bombardment. The products of such bombardments were expected to be precisely those berkelium and californium isotopes which had been difficult or impossible to study previously with the limited amounts of target material available. Accordingly, one of the purposes of this work was the exploitation of these new supplies of target isotopes in the search for new berkelium and californium isotopes.

Simultaneously with the production of new target isotopes, the techniques and instrumentation of heavy-element research had undergone great development. New methods for the use of the cyclotron and improved chemical methods increased both the speed and sensitivity of experiments in the heavy-element field. The application of nuclear spectrometers and coincidence methods similarly placed new emphasis on the detailed study of the modes of nuclear decay, and the developing systematics of nuclear properties made it highly desirable to extend the knowledge of such properties to the isotopes previously only identified.

The combination of these several factors resulted in the initiation of the work reported herein, in which a systematic investigation of the berkelium and californium isotopes was undertaken. In view of the comprehensive recent studies of the heavier isotopes produced by neutron irradiation, this work was limited principally to those berkelium and californium isotopes which can be produced only by charged-particle bombardments. Within these limits -- and the limits imposed by time and techniques -- the production, characterization, and decay properties of the light isotopes of berkelium and californium have been investigated.

II. PRODUCTION AND PREPARATION OF TARGET MATERIALS

A. Production of Target Isotopes

Four isotopes of americium and curium were used as principal target materials in this work, Am^{241} , Am^{243} , Cm^{242} , and Cm^{244} . Each of these possesses a conveniently long half life (the 162-day Cm^{242} is the shortest), and each can be produced in multimicrogram amounts and in suitable isotopic purity. The production and isolation of these materials was a prerequisite for the later investigations and constituted an important part of this work.

1. Americium-241

Americium-241 was obtained from the beta decay of Pu^{241} in samples of mixed plutonium isotopes separated in the course of the routine production of Pu^{239} . Since Pu^{241} is the only beta emitter commonly remaining after initial chemical isolation of the plutonium, the

americium which "grows in" is isotopically pure Am^{241} . The amount of americium formed by the decay may be calculated from the amount of Pu^{241} present in the separated plutonium, the half lives of the isotopes involved, and the period of decay.

Several milligrams of Am^{241} for target materials were obtained from plutonium solutions that had aged for several years. The americium was chemically separated as described later and stored until needed. Since little time elapsed before use, no further separations of the americium from its Np^{237} daughter were required.

2. Curium-242

Curium-242 was prepared by neutron irradiation of a fraction of the Am^{241} obtained as above. Radiative neutron capture by Am^{241} leads mainly to the 16-hr isomer of Am^{242} , which beta decays to the desired curium isotope.¹⁴ The isotopic purity of the resulting curium, however, is strongly dependent on the duration of the irradiation, since further neutron capture by the intermediate Am^{242} or by the Cm^{242} product leads to the formation of Cm^{243} and Cm^{244} , according to the reaction path shown in Fig. 1. In practice, the yield of Cm^{242} must be balanced against the desired purity of the product. The quantities of the various curium isotopes produced in short irradiations of Am^{241} are shown in Fig. 2 as a function of the time of irradiation. These data were calculated with the aid of an approximation method developed by H. P. Robinson¹⁵ and using the capture and fission cross sections collected by Robinson.¹⁶ A neutron flux of 3×10^{14} neutrons/cm²/sec was chosen as a typical value for the Materials Testing Reactor at Arco, Idaho, in which all these irradiations were performed.

The Cm^{242} used in this work was prepared by a 24-hr irradiation of Am^{241} and was estimated to contain less than 0.2% by mass of other curium isotopes. It was chemically separated from plutonium, americium, and fission products and repurified before use to eliminate the Pu^{238} daughter.

3. Americium-243 and Curium-244

The two remaining isotopes, Am^{243} and Cm^{244} , were produced by the prolonged neutron irradiation of Pu^{239} , which yielded, in addition to americium and curium, several isotopes of berkelium, californium,

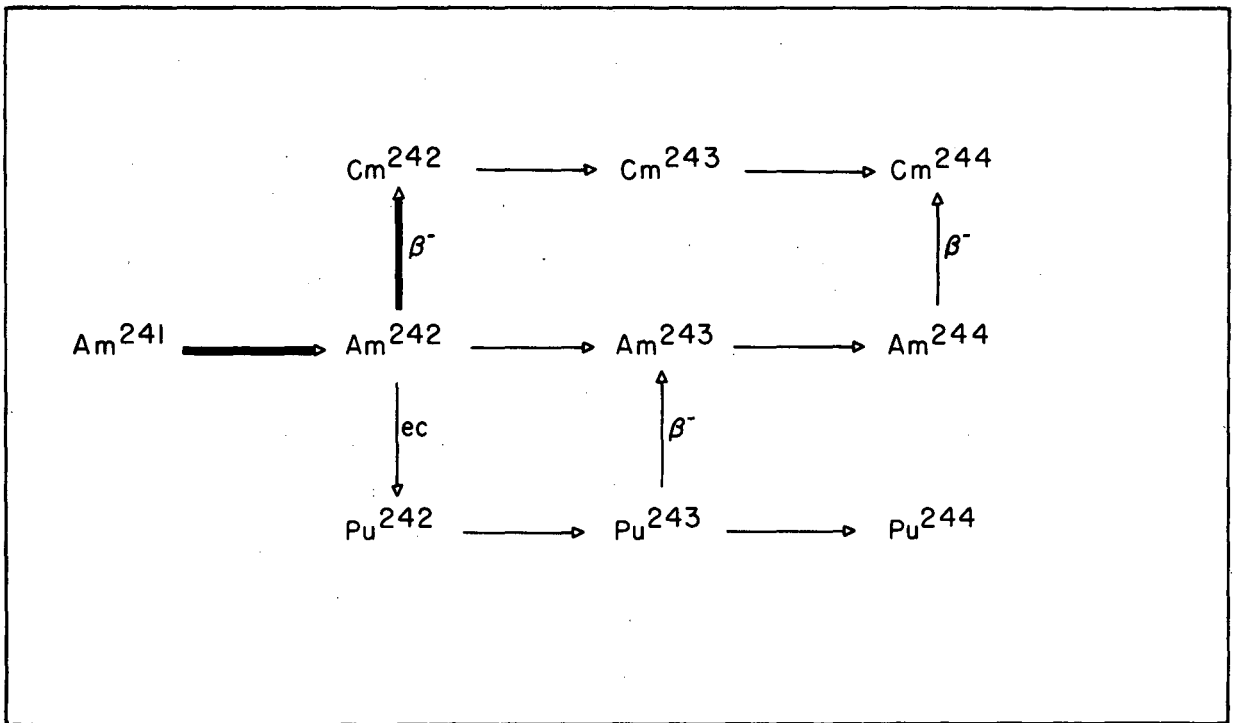

MU-11692

Fig. 1. Reaction paths in the thermal-neutron irradiation of Am^{241} .

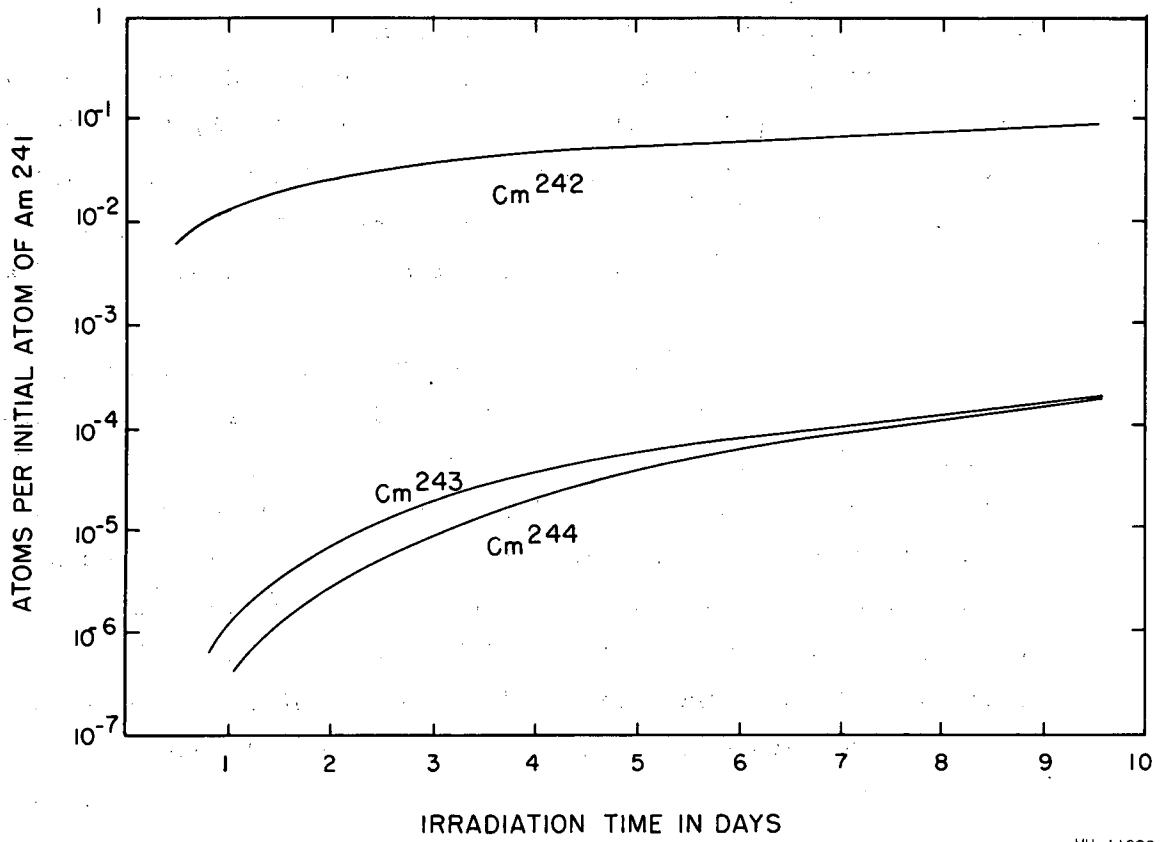

MU-11693

Fig. 2. Yields in the thermal-neutron irradiation of Am²⁴¹.

einsteinium, and fermium. The reaction path leading to these isotopes is complicated by a number of competing steps; however, the most important reactions taking place in irradiations of several years' length are indicated in Fig. 3. Although the direct calculation of the yields of the higher-order products of these irradiations is extremely tedious, this problem can be solved by means of an analogue computer with an accuracy limited only by the accuracy with which the appropriate cross sections and half lives are known. The results of such a computation of the production of Am^{243} and Cm^{244} as a function of irradiation time are shown in Fig. 4, which was obtained by use of the cross sections from the compilation by Robinson, as before.

The isotopic compositions of the americium and curium from these sources depends again on the conditions of the irradiation. In long irradiations at high flux, however, the relevant parameters are such that almost pure Am^{243} (>99%) and Cm^{244} (~95%) are formed; the principal impurities in the latter are the heavier curium isotopes, Cm^{245} and Cm^{246} .

The Am^{243} and Cm^{244} used in these experiments were among the products of a two-year irradiation of 168 milligrams of Pu^{239} in the Materials Testing Reactor. Several milligrams of americium and several hundred micrograms of curium were isolated from the sample and prepared for use as cyclotron targets. Mass spectrographic analysis showed the isotopic compositions given in Table I. The abundance of Cm^{242} in this material was reduced from its initial value of 0.6% at the end of irradiation to that shown in the table by the 18-month decay period which elapsed before the repurification and use of these fractions.

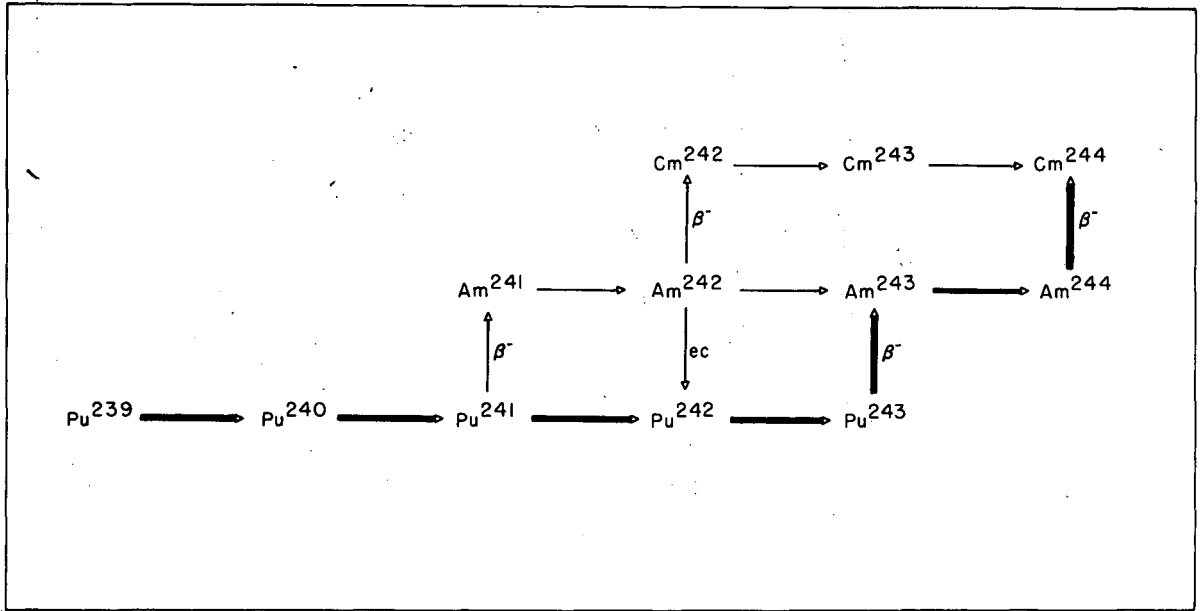

MU-11694

Fig. 3. Reaction paths in the thermal-neutron irradiation of Pu^{239} .

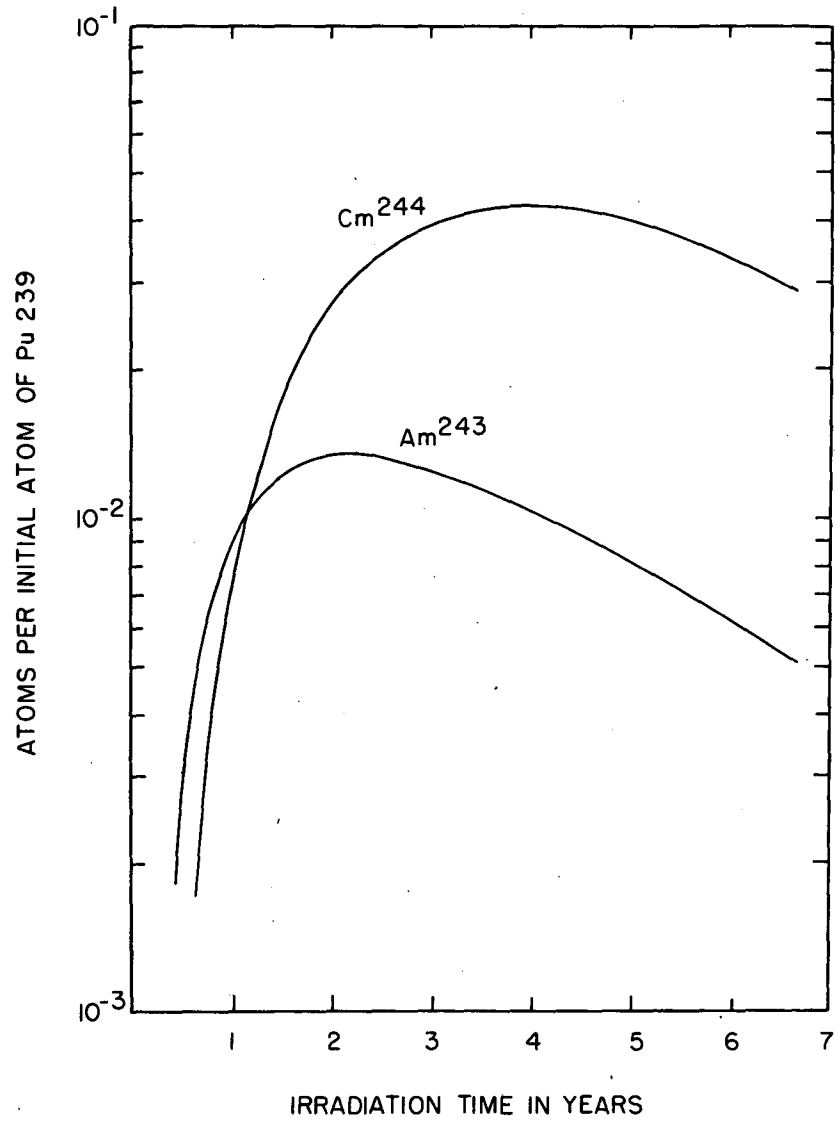

MU-11695

Fig. 4. Yields in the thermal-neutron irradiation of Pu^{239} .

Table I

Isotopic composition of Am ²⁴³ and Cm ²⁴⁴ target materials	
<u>Curium Sample</u>	
Cm ²⁴²	0.06%
Cm ²⁴³	<0.01% (estimated)
Cm ²⁴⁴	94.14%
Cm ²⁴⁵	1.9 %
Cm ²⁴⁶	3.4 %
Cm ²⁴⁷	0.05% (estimated)
<u>Americium Sample</u>	
Am ²⁴¹	0.02%
Am ²⁴²	<0.01% (estimated)
Am ²⁴³	99.98%

B. Target Preparation

Extensive chemical processing of the various target materials was required in order to meet the stringent demands for chemical and radio-chemical purity and suitable physical form imposed by the bombardment techniques employed. In addition to the standard procedures of heavy-element chemistry, several new methods were developed to achieve these ends.

1. Initial Separations

Americium and curium isotopes produced by the methods discussed were isolated from fission products and miscellaneous induced activities, and from other actinide elements, by a combination of precipitation and ion-exchange chemistry. In brief summary, the rare-earth and actinide fractions were initially separated from the bulk of the other elements present by precipitation as hydroxides and subsequently as fluorides. After dissolution of the fluoride precipitate in boric acid, the rare earths were separated from the actinides by one of two ion-exchange methods involving either elution from cation-exchange resin with 20% ethanol solutions saturated with hydrochloric acid¹⁷ or elution from anion-exchange resin with 10- molar lithium chloride solutions¹⁸ at elevated temperatures. Either method results in a clean separation of

the two groups of elements. Separations of the individual actinide elements from one another was accomplished by elution from cation-exchange resin (Dowex-50) under carefully controlled conditions with ammonium α -hydroxyisobutyrate or ammonium lactate as the eluting agent. Most of these procedures have been discussed in detail in the papers by Thompson et al.¹⁷ and by Choppin et al.^{19,20}

2. Final Isolation

Final purification of the desired isotopes from inactive contaminants introduced during chemical processing was effected by means of an ion-exchange procedure developed for this work. The americium or curium sample was evaporated to dryness, dissolved in 50 to 100 microliters of 0.05 M hydrochloric acid, and adsorbed on the top of a 0.3-by-10-cm column of cation-exchange resin (Dowex-50 x 4, 500-600 mesh). The resin column was then washed with several drops of 1 M hydrochloric acid in order to elute ammonium salts, and salts of the alkali and alkaline earth metals. Finally, the americium or curium was eluted gradually with 6 M hydrochloric acid at a flow rate of 1 drop (20 microliters) every two minutes. Under optimum conditions, more than 95% of the target material was collected in a volume of less than 60 microliters and in a high state of chemical purity. Contamination of the product in the course of the elution was minimized by using carefully cleaned ion-exchange resin of spectroscopic purity and by preparing the eluant from washed, filtered hydrochloric acid gas and conductivity water, subsequently stored in quartz before use.

The behavior of a number of likely impurities in this separation was investigated in a series of elution experiments. It was found that anionic species, such as silicates, are not absorbed by the resin and pass through the column during the washing step, while ammonium salts and salts of the alkali and alkaline earth metals are eluted by 1 M HCl as mentioned. Ferric iron, aluminum, and platinum are eluted very slowly by 1 M hydrochloric acid, but elute more rapidly than the trivalent actinides with 6 M hydrochloric acid and thus are separated from the latter. The separation of these elements from americium is illustrated in the elution curve of Fig. 5.

The elution positions of the rare earths in this system were also

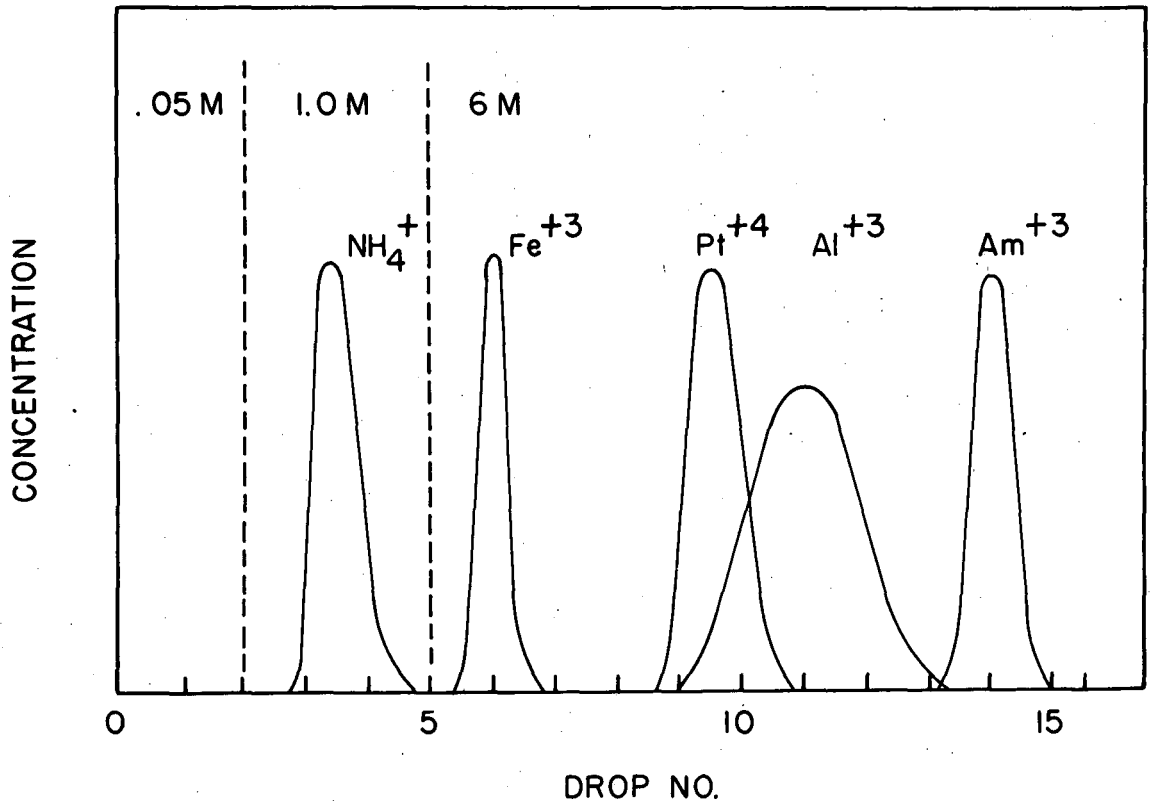

MU-11696

Fig. 5. Separation of Am from some common impurities.

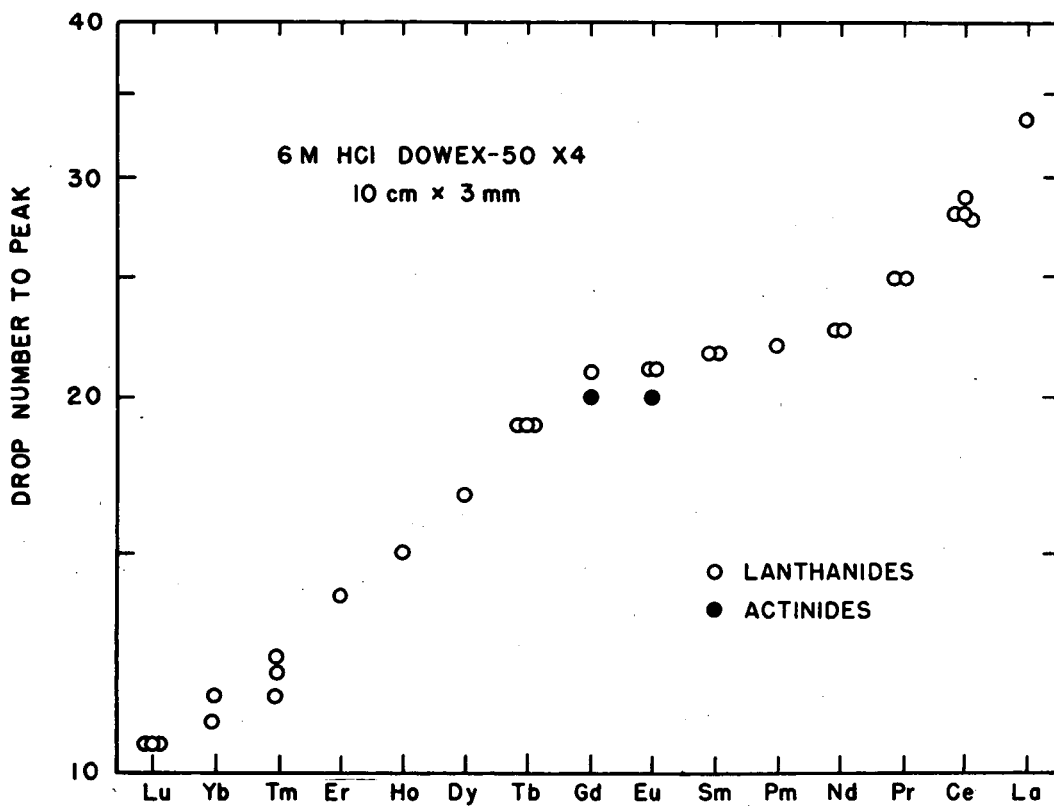

MU-11697

Fig. 6. Elution positions of the rare earths, americium, and curium.

determined, with the results shown in Fig. 6. Here the number of drops (20 microliters per drop) of 6 M hydrochloric acid passed through the resin column when the concentration of the particular element in the effluent was at a maximum is plotted against atomic number. Comparison with the elution positions of americium and curium, shown opposite their lanthanide analogues europium and gadolinium, makes it clear that excellent separations of americium and curium from both the lightest and the heaviest rare earths may be achieved. Although middle-weight rare earths are not discriminated against, they are ordinarily of little importance as contaminants, since all but the heaviest rare earths are extremely well separated by the other procedures and only lanthanum and cerium occur in significant amounts in common laboratory reagents.

This procedure was used routinely in this work for the production of concentrated solutions of the target materials in a high state of chemical purity suitable for the preparation of cyclotron targets by direct evaporation, vacuum sublimation, or electrodeposition, as required.

3. Direct Evaporation

The direct bombardment of americium or curium in target holders of the usual type places few special requirements on the form of the sample other than limitation to a small area (usually a square centimeter or less) and conversion of the target material to a relatively infusible form. These requirements were usually met by evaporation of a solution of the target material directly onto a gold or aluminum plate followed by ignition of the target material to the oxide in a muffle furnace or induction heater. The solutions were evaporated into the desired area a few microliters at a time by using a screw-controlled syringe mounted on a micromanipulator. After a few microliters of solution were deposited, it was evaporated to dryness under a heat lamp before the next portion of solution was applied; the progress of the evaporation was observed under a magnifying glass. Repetition of this process and careful ignition of the supporting plates and of the evaporated material rendered the target suitable for insertion into the target assembly.

4. Vacuum Sublimation and Electrodeposition

Targets intended for use with the recoil-collection equipment to be described later presented more difficult problems. The target area was limited to a region 1.1 by 6 millimeters ($\sim 1/15 \text{ cm}^2$), and the final total surface density of the deposited target was required to be less than about 30 micrograms per square centimeter at any point. Two procedures were found to yield targets that met these conditions of extreme uniformity and thinness.

Conventional vacuum-sublimation methods were modified for use with actinide elements by providing for the high temperatures at which their vapor pressures become significant and by the design of special filament assemblies giving extreme collimation to the beam of evaporated molecules.²¹ Although these improvements provided targets of great uniformity and thinness, these advantages could be obtained only under condition of low yield. Consequently, this procedure was used only in those cases in which loss of target material was of little importance.

Most of the recoil targets were prepared by a cathodic electrodeposition procedure modified by B. G. Harvey and the author. In this procedure, the target materials were evaporated to dryness, dissolved in 6 M ammonium chloride solution adjusted to pH 1.5 with hydrochloric acid, and transferred to the special cell shown in Fig. 7. The foil on which the target was to be deposited served as the cathode and was supported on a soft plastic backing strip to insure a watertight seal around the base of the cell. Gold foil was the usual cathode material, although platinum was also used successfully. The bottom of the cell was shaped in such a way that its internal dimensions in contact with the cathode foil were those of the desired target area. Electrolysis of the solution at a current density of 1.2 amp per square centimeter of cathode area resulted in the deposition of the target material on the cathode as the hydroxide. After 45 minutes, the electrolyte was made alkaline with excess ammonium hydroxide and electrolysis stopped. The cathode was then removed from the cell, washed gently with water and acetone, and ignited in an induction heater or muffle furnace.

Since most of the elements that precipitate as hydroxides or hydrous oxides are electrodeposited by this procedure, trace quantities

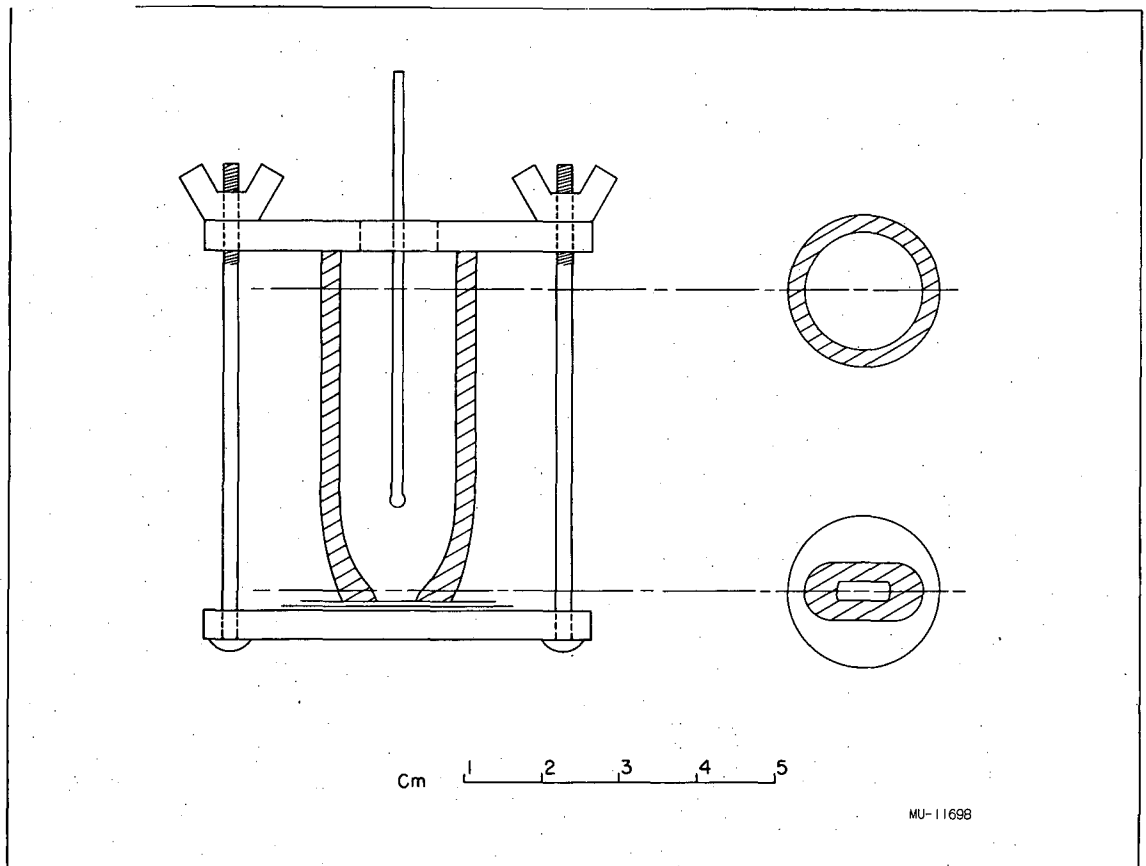

Fig. 7. Electrodeposition cell.

of these elements must be excluded from the electrode surfaces, electrolyte, and cell parts as well as from the target material. With careful attention to these points satisfactory targets were consistently obtained. The over-all yield through the deposition procedure was commonly 80 to 85%.

III. BOMBARDMENT TECHNIQUES

A. Target Assemblies

1. "Microtarget" Assembly

Several types of target assemblies have been developed in recent years for the bombardment of radioactive targets in a controlled and safe manner. In general, these assemblies must provide for the confinement of the sample to a small, leak-proof region, for degrading foils to adjust the energy of the bombarding particles to the desired energy, and for cooling of the target and degrading foils.

The "microtarget" assembly, which was used extensively in this work, consists of a water-cooled aluminum collimator, an aluminum spacer located between two degrading foils and provided with jets for directing cooling gas on the foils, and a mounting block for the target and cover which provides cooling water to the back of the target. The target material is contained in a dishlike metal holder, several centimeters in diameter, with a slightly recessed center. The holder is covered with a thin foil, usually 0.001-inch dural, and the holder and cover clamped in the target mounting. After bombardment the target holder and cover are removed and the target and products dissolved for recovery and separation. Up to several milligrams of target material may be accommodated in this type of assembly.

2. Deflector Channel Probe

During the course of this work, a new type of target assembly was developed by Ghiorso, Rossi, and others,²² in which the products of bombardment were physically separated from the target material by the recoil mechanism. Use of this equipment avoided the necessity for separating the products of a bombardment from the target material, permitting the search for short-lived isotopes and repeated use of a single target.

The essential features of the recoil-collection probe are indicated schematically in Fig. 8. After passing through water-cooled collimators, the beam is degraded to the energy desired by passage through a degrading foil and then through the target foil. Finally, the bombarding particles enter the evacuated region behind the target and, after passing through a very thin collector foil, are stopped by a water-cooled Faraday cup which also serves to measure beam intensity. The degrading and target foils are cooled by helium forced under pressure through the space between the two.

When a reaction occurs in the target, the product nuclei are driven forward as required by momentum conservation and, providing that the majority of the linear momentum is retained by the product nucleus and that the target deposit is sufficiently thin, the recoil nuclei travel forward through the evacuated region and may be collected on a thin foil and removed from the probe for examination.

Since the product nuclei are automatically separated from all the target except that small fraction transferred to the collector by elastic and inelastic scattering processes, the required chemical separations are only from fission products and activities induced in the catcher foil. To some extent, fission-product collection may be reduced by using catcher foils thin with respect to the range of fission fragments. Gold foils 0.0001 inch in thickness have been used successfully for this purpose.

Although recoil-collection efficiency was expected to approach 100% under ideal conditions of probe alignment and target thinness, it was desirable to investigate this directly and to establish additional characteristics of the recoil-collection process.

a. Range-energy relation for recoil nuclei

The stopping of recoil nuclei from reactions with helium ions in the energy range used in this work differs essentially from the stopping of fast light particles. As discussed by Bohr,⁶⁶ the principal stopping process for slow heavy nuclei is the near-elastic "nuclear" collision mechanism. While an approximate range may be estimated for recoils from natural alpha decay stopping in a light element, for example, the concept of range is of little significance for stopping by elements whose mass

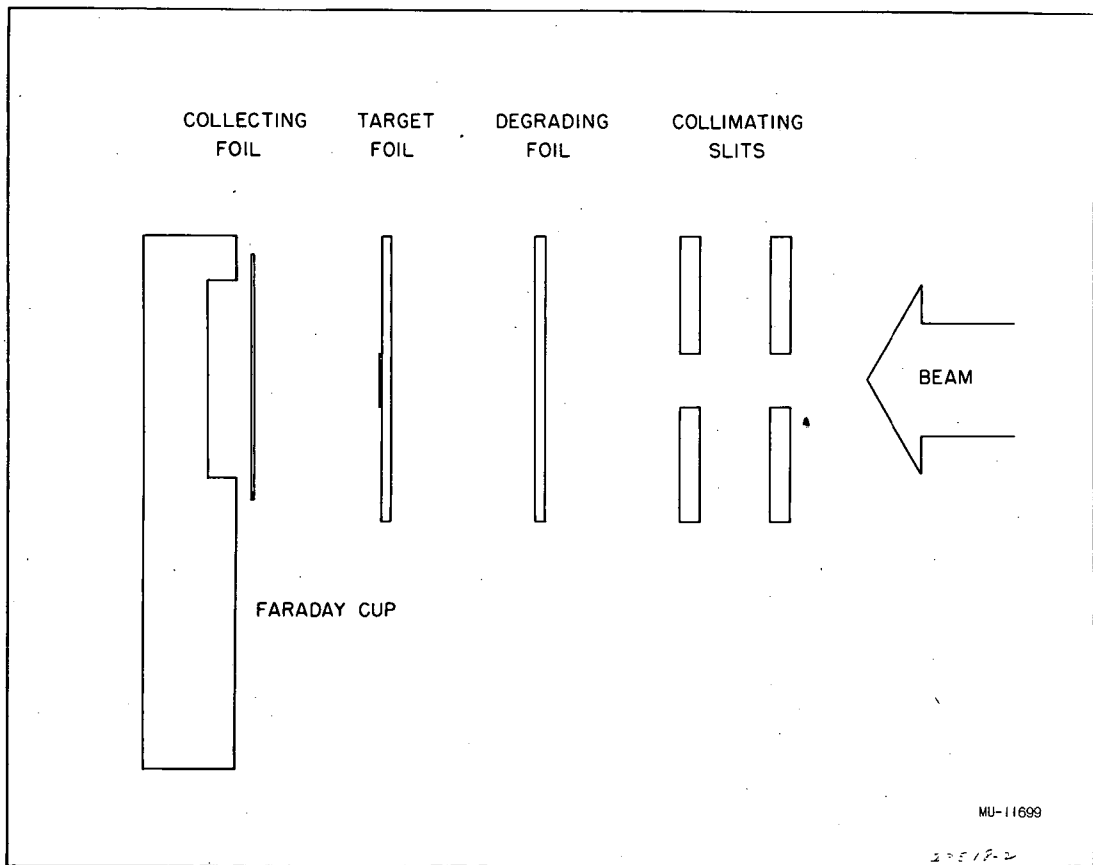

Fig. 8. Schematic diagram of the deflector-channel probe.

is comparable with that of the stopped nuclei. Under these conditions the recoil nucleus may lose most of its energy in a single collision, and the stopping process then resembles typical diffusion phenomena, in which a transport mean free path occupies a place analogous to the familiar "range".

In spite of this and other large uncertainties in interpretation, it was highly desirable to obtain an estimate of the "range" of recoil nuclei in heavy elements as a rough indication of maximum permissible target surface densities for use with the recoil-collection equipment.

"Range"-energy curves were determined for recoil particles over the energy range corresponding to 25- to 48-Mev alpha particles for astatine recoils in bismuth metal. A stack consisting of foils of bismuth volatilized on aluminum and alternating with pure aluminum foils was bombarded with 48-Mev helium ions. The evaporated bismuth deposits were infinitely thick with respect to the range of the recoils, but thin with respect to the bombarding particles. After bombardment, the bismuth foils and the aluminum catcher foils were counted for the alpha activity of At^{211} in equilibrium with its Po^{211} daughter. The range of the recoiling astatine nuclei was computed from the known density of the bismuth foils and the ratio of total At^{211} - Po^{211} produced to the amount ejected from the bismuth foils. The helium-ion energy at each foil was calculated from the known thickness of the various foils in the stack. The results of these experiments are shown in Fig. 9, in which the range in micrograms of bismuth per square centimeter is plotted against the energy of the bombarding helium ions. An approximate reduction of these data in terms of the energy of the recoils may be made by assuming that the neutrons emitted from the recoil nucleus carry off negligible momentum.

b. Angular distribution of recoil nuclei

Rough measurements of the angular distribution of the recoil nuclei were also made, with a Cm^{244} target of less than 5 micrograms per square centimeter surface density. In this experiment Cf^{246} recoils from Cm^{244} ($\alpha, 2n$) reaction were collected on an aluminum foil located in the usual position ~12 millimeters from a 0.7-by-4.5-millimeter target. After bombardment, the aluminum foil was sectioned into 0.1-millimeter squares,

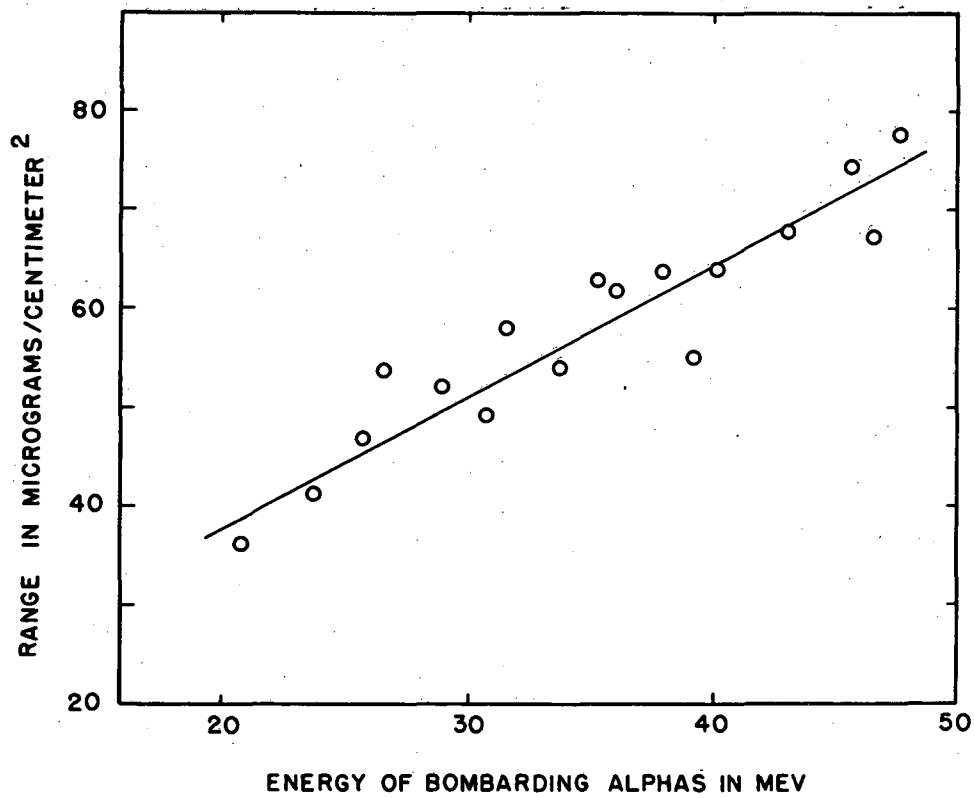

MU-11700

Fig. 9. Range-energy curves for astatine recoils in bismuth metal.

which were counted for Cf²⁴⁶. . . No appreciable dispersion of the recoil beam was evident, an observation consistent with calculations of the dispersion that occurs owing to the emission of neutrons with a reasonable energy spectrum from the compound nucleus, the conditions of low resolution obtaining in this experiment, and the short flight path of the recoils.

c. Recoil collection efficiency

Finally, comparison of the yields of several (α , 2n) reactions in the heavy-element region obtained by recoil-collection and direct-bombardment methods were made. The two types of experiment were in consistent agreement within the limits of error of the individual measurements. It should be noticed, however, that non-compound-nucleus reactions, in which the majority of the momentum of the bombarding particle is not transferred to the recoiling product, may be important in some cases, and would not necessarily lead to the high recoil-collection efficiencies observed here.

B. Bombardment Chemistry

1. General Procedures

Separations of transplutonium elements from various other elements and from one another have been reviewed by many authors.^{17,23,24} Most of these methods are directly applicable to the isolation of the products of cyclotron and pile bombardments with little modification and need not be detailed here. Several procedures, however, are particularly suitable for the fast separation necessitated by short-lived isotopes.

One of the most useful procedures involves the elution of actinide elements from anion-exchange resins such as Dowex- A-1, by 6 to 8 M hydrochloric acid at elevated temperatures. As has been reported by Kraus and Nelson,²⁵ very many elements are present in 6 M hydrochloric acid as anionic species and may be absorbed on anion-exchange resin. Since the trivalent actinides are adsorbed little if at all under these conditions,¹⁷ a large fraction of the fission products and induced activities may be eliminated in a single elution of this type. In many experiments no other separation of the products was necessary before analysis.

Separation of the actinides from one another, when required, was accomplished by elution from Dowex-50 cation-exchange resin with solutions of ammonium α -hydroxy isobutyrate as described by Choppin et al.^{19,20} Using the techniques and equipment described by Thompson et al,¹⁷ essentially complete separations were regularly obtained between neighboring actinide elements in total times of 30 to 40 minutes.

Rare earths are also separated by this method but, in general, not from the actinides. Even without preliminary group separations, however, a given actinide may usually be obtained free from all but one or two rare earths. In many cases the presence of small amounts of the latter activities is not objectionable. When it was necessary to eliminate rare earth activities completely, the separation was made by elution from colloidal Dowex-50 cation-exchange resin with 20% ethanol solution saturated with hydrochloric acid.¹⁷

2. Fast Electrodeposition

Preparation of the various samples for counting or pulse-height analysis was usually done by evaporation of a solution containing the activity onto platinum or aluminum foils. For the rapid preparation of very thin uniform samples, however, the electrodeposition procedure discussed previously was used in a modified form. The several drops of 6 M hydrochloric acid solution required to elute the actinide elements from an anion-exchange column, for example, were collected directly in a cylindrical glass cell 1 centimeter in diameter. The acid solution was then neutralized dropwise with alternating portions of ammonium hydroxide and hydrochloric acid of a series of concentrations, until the solution was just acid to methyl red. Electrolysis of this solution at high current densities (2 amp per cm²) yielded thin uniform deposits of the actinide elements in relatively high yield.

Some of the parameters affecting this electrodeposition were investigated, with the results shown in Figs. 10 and 11. Electrolysis times of 1.5 to 2 minutes at ~ 2 amp per cm² were commonly employed, although longer depositions at lower current density were preferred for the preparation of plates of longer-lived activities. The data of Figs. 10 and 11 are interpretable in terms of the formation of a cathode layer of high pH and the precipitation of the depositing element as a

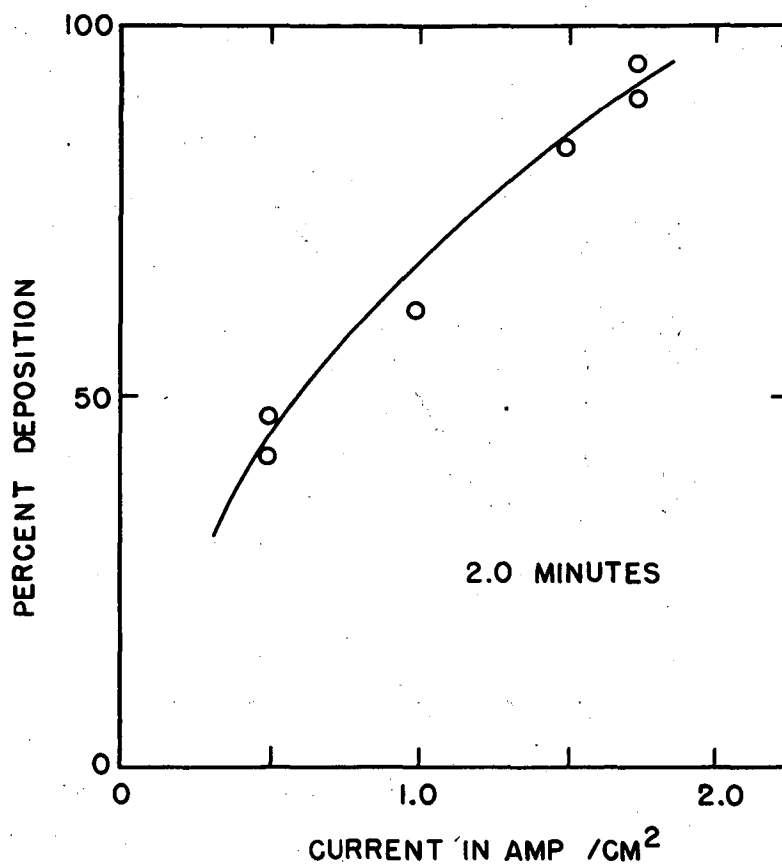

MU-11701

Fig. 10. Electrodeposition yield as a function of current density.

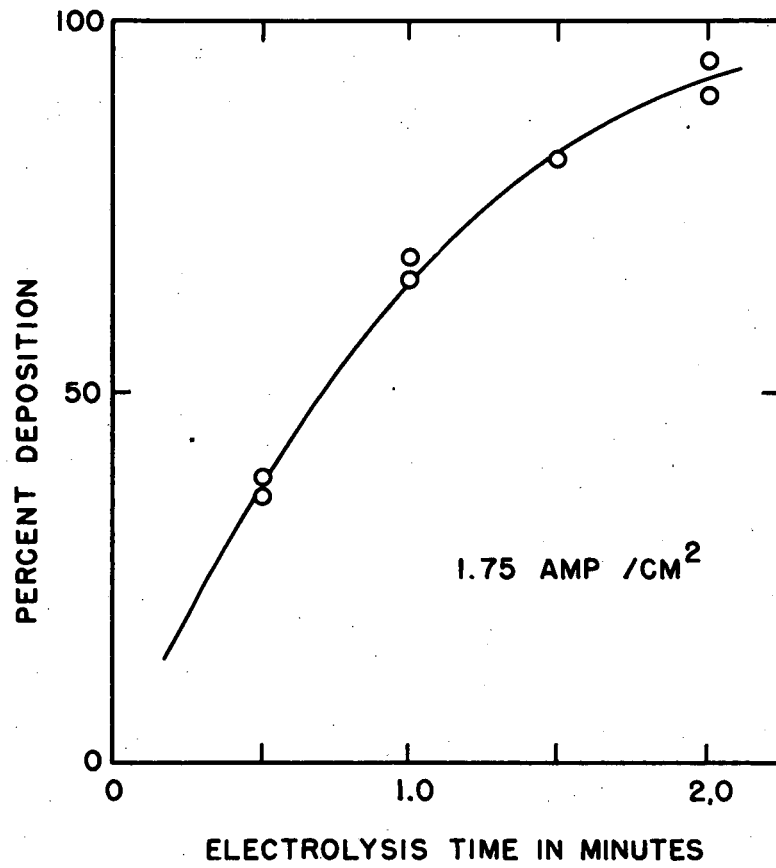

MU-11728

Fig. 11. Electrodeposition yield as a function of electrolysis time.

hydroxide in this layer. Assuming such a mechanism, the rate of deposition should be dependent on the extent of the cathode layer and the rate of diffusion of the depositing element into that layer. Under the conditions detailed here, however, violent gas evolution provides efficient stirring in the electrolyte, supplanting diffusion in the transfer of material to the cathode layer. The smooth rise of observed yield with current density and numerous observations of the effect of complexing agent in the electrolyte, the types of metals that can be deposited, and the redissolution of the deposit on interruption of the electrolysis all support the suggested mechanism.

C. Instrumental Methods

In addition to standard counting devices, several instruments were used in this work, including pulse-height analyzers and associated detection systems and coincidence circuits, and an alpha-particle spectrograph. All these instruments have been reported in previous papers from this laboratory.

Alpha-particle pulse-height analysis was done principally with a 48-channel analyzer designed by Ghiorso and Larsh,²⁶ in conjunction with a gridded ionization chamber filled with a mixture of argon and nitrogen. The resolution obtainable with this equipment was commonly 30 to 40 kev (width at half maximum) at 45% effective geometry.

A similar analyzer, equipped with coincidence circuitry,²⁷ was used for the decay-scheme studies. A variety of detectors was employed with this equipment: thallium-activated sodium iodide crystals for gamma rays, a xenon-filled proportional counter for soft radiations, anthracene crystals for beta particles, and zinc sulfide screens for alpha particles. Used singly or in combination, this range of available detectors provided great flexibility in the experiments.

Finally, alpha particles from Cf^{246} were studied in the alpha-particle spectrograph described by Reynolds.²⁸

IV. EXCITATION FUNCTIONS

In the course of the work reported, several excitation functions for reactions induced by helium-ion bombardments of americium and curium were obtained. Not only is there intrinsic interest in the mechanism

of nuclear reactions, but also a knowledge of such results proved exceedingly useful in the preparation of berkelium and californium isotopes and in the assignment of mass numbers.

A. Experimental Methods

All the reactions studied were induced by helium ions from the 60-inch cyclotron at the Crocker Laboratory. Helium ions of maximum energy of about 48 Mev are available from this source, although the interposition of sealing foils and target materials usually reduced the practical maximum energy to about 44 Mev. The lower limit of the energy range available for study is determined largely by the Coulomb barrier for helium ions on heavy elements. (In americium and curium this barrier is at about 18 Mev.) Within this range, a number of reactions were studied in a preliminary way.

Depending on the nature of the target material and the amounts available, several experimental methods were used. Almost half of the bombardments were made in the collimated beam external to the cyclotron, with the microtarget assembly. The remainder of the bombardments were made by the recoil-collection technique with the deflector-channel probe. The simplification in chemical procedure permitted by the latter method made it distinctly advantageous. Because of the uncertainties in recoil yield due to target thickness, however, several similar measurements were always made by one of the other methods as a check of the equipment.

The energy of the bombarding particles was varied by the interposition of weighed aluminum foils between the collimating slits and the target. The initial beam energy was known to within 0.1 Mev from the operating parameters of the cyclotron and from the frequent measurements by other groups using the cyclotron. The final energy of the alpha particles was calculated from the initial energy and the amount of aluminum degrading foils, using the range-energy curves of Aron, Hoff, and Williams.²⁹ The intensity of the beam was monitored continuously by carefully calibrated equipment and simultaneously integrated.

Following irradiation of the targets, appropriate chemistry was carried out to isolate the products in a form suitable for counting. In those cases where there were uncertainties in chemical yield, known quantities of tracer were added and the results adjusted to the measured recovery of tracer.

Measurement of the disintegration rates of the products was done by alpha-particle counting whenever possible. In every case further identification was obtained by alpha-pulse analysis of the products. The distinctive alpha-particle energies and chemical behavior of the products provided a high degree of certainty in their identification.

A few of the determinations of yields of electron-capture isotopes were made by counting in a windowless proportional counter. These counters have an inherently high counting efficiency for electron-capture isotopes, but are critically dependent on sample thickness, since they are essentially sensitive only to electrons. Under ideal conditions of infinitely thin deposits on a heavy-element support, the theoretical efficiency for electron-capture isotopes nears 100%. In an attempt to approach these conditions, samples for this type of counter were electro-deposited over the surfaces of 1-inch-diameter platinum counting plates. The active deposits so obtained were invisible to the eye and apparently uniform. Direct comparison of disintegration rates obtained in this manner for Bk²⁴⁵ with disintegration rates determined by alpha counting agreed to within 10% in the few cases studied. Counting efficiencies of 90% were accordingly assumed for samples prepared in this manner.

B. Excitation Functions

1. Helium ions on Curium-244

The most nearly complete excitation functions were obtained for the target isotope Cm²⁴⁴. The results of these measurements are shown in Figs. 12 and 13. The data for the (α , 2n) reaction yielding of Cf²⁴⁶ were obtained by the counting of the 6.76-Mev alpha particles from this isotope. The decay of Cf²⁴⁶ was assumed to proceed entirely by alpha decay, in accordance with the work of Hulet⁶ and with the long half-life for electron capture expected on the basis of the estimated electron-capture decay energy.³⁰ The points shown for this reaction include those from both direct and recoil-collection bombardments. No systematic difference between these sets of points is evident. The limits of error shown are the standard deviation of the counting procedure and do not include other sources of error. While the individual points reflect sources of variation other than counting statistics, the

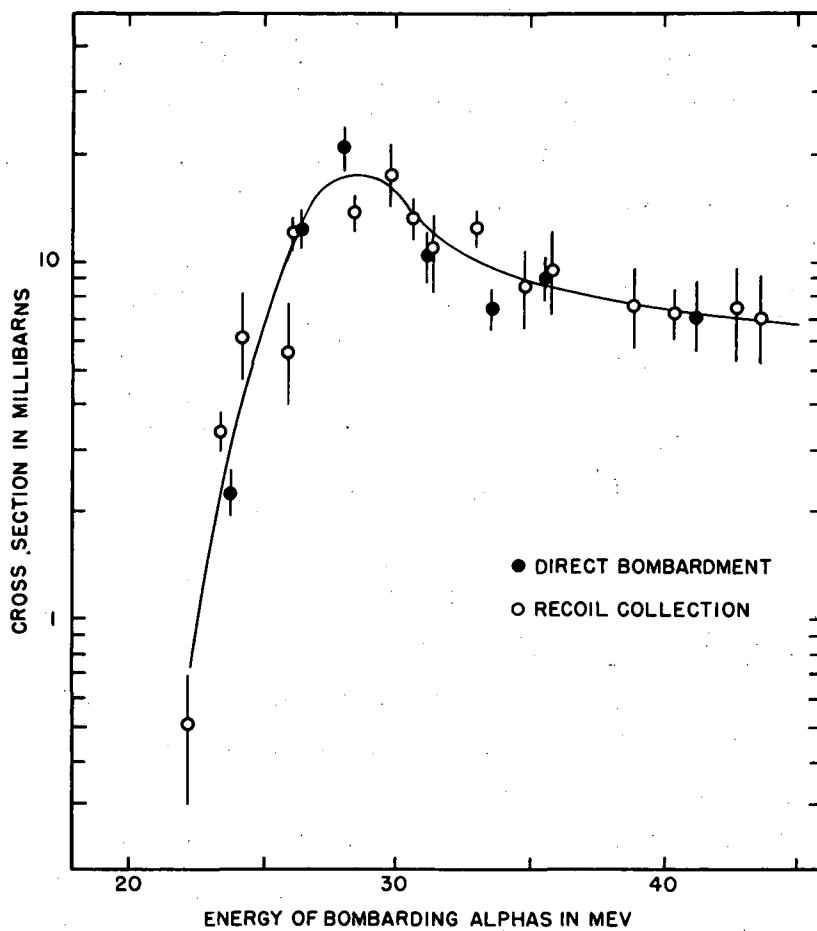

MU-11702

Fig. 12. Excitation function for the $^{244}\text{Cm}(\alpha, 2n)^{246}\text{Cf}$ reaction.

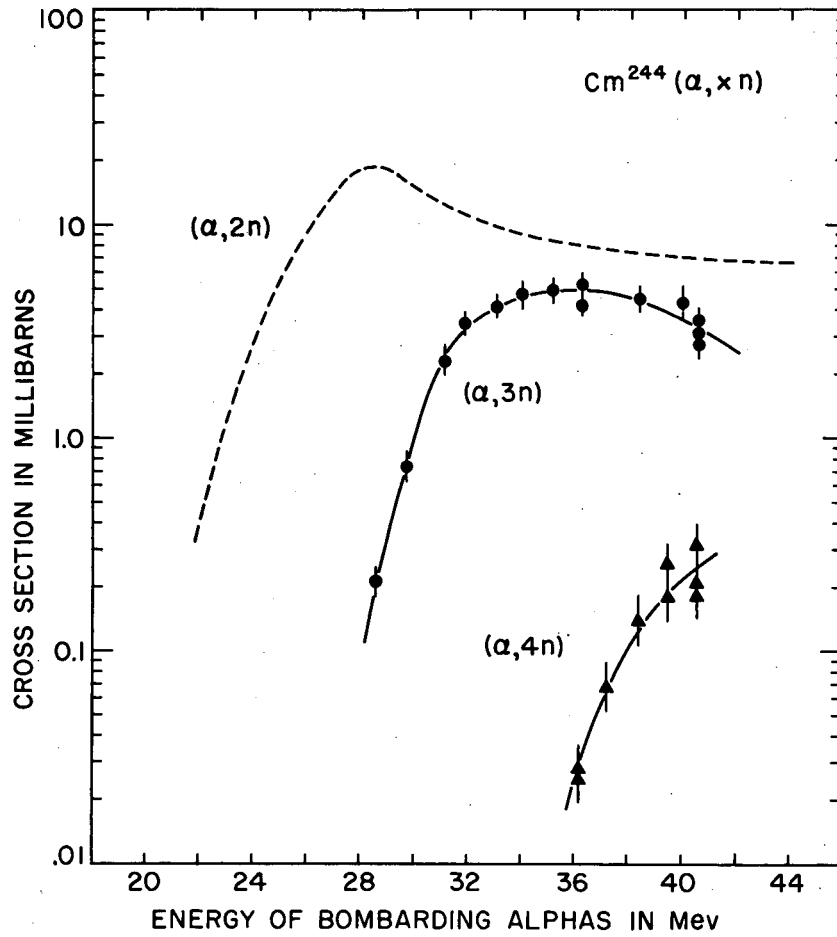

MU-11703

Fig. 13. Excitation functions for some (α, xn) reactions on Cm^{244} .

best curve through all the points is felt to be accurate to $\pm 10\%$.

Excitation functions for the $(\alpha, 3n)$, and $(\alpha, 4n)$ reactions on Cm^{244} were determined relative to the yield of the $(\alpha, 2n)$ product Cf^{246} . These results are shown in Fig. 13. The $(\alpha, 3n)$ product, Cf^{245} , was determined by direct counting of its 7.11-Mev alpha particles.³¹ The electron-capture branching ratio was determined in separate experiments and used to calculate the cross sections shown. A small correction to the observed alpha disintegration rate of Cf^{245} was necessitated by the presence of the 6.17-Mev alpha particles³¹ from the $(\alpha, 4n)$ product Cf^{244} . No attempt was made to resolve these alpha groups into their components, since the small contribution from Cf^{244} could be accurately subtracted.

The amount of Cf^{244} produced in the bombardments was determined from the alpha disintegration rate of its daughter Cm^{240} , measured after complete decay of the parent isotope. From the measured 25-min half life of Cf^{244} and its electron-capture decay energy estimated from closed cycles,³⁰ an electron-capture half life of 2 to 5 days was expected.³² Accordingly, cross sections were computed on the assumption of decay only by alpha emission.

The few cross sections shown in Fig. 14 for the (α, n) , $(\alpha, p2n)$, and $(\alpha, p3n)$ reaction on Cm^{244} were determined by counting the several products in windowless proportional counters, assuming an arbitrary 90% counting efficiency for electrodeposited samples on platinum backing plates. In these experiments, the californium and berkelium fractions were chemically isolated soon after bombardment. The initial disintegration rates were determined by resolution of the decay curves for the mixtures of berkelium and californium isotopes. The results shown here are intended only as order-of-magnitude indications and should not be compared with the more careful measurements of $(\alpha, 2n)$, $(\alpha, 3n)$, and $(\alpha, 4n)$ excitation functions.

2. Helium ions on Americium-243

A preliminary study of some helium-ion-induced reactions of Am^{243} was also undertaken in connection with the mass assignment and identity of the $(\alpha, 3n)$ product Bk^{244} . These results are shown in Fig. 15. The yields of the several isotopes were determined by alpha-pulse analysis

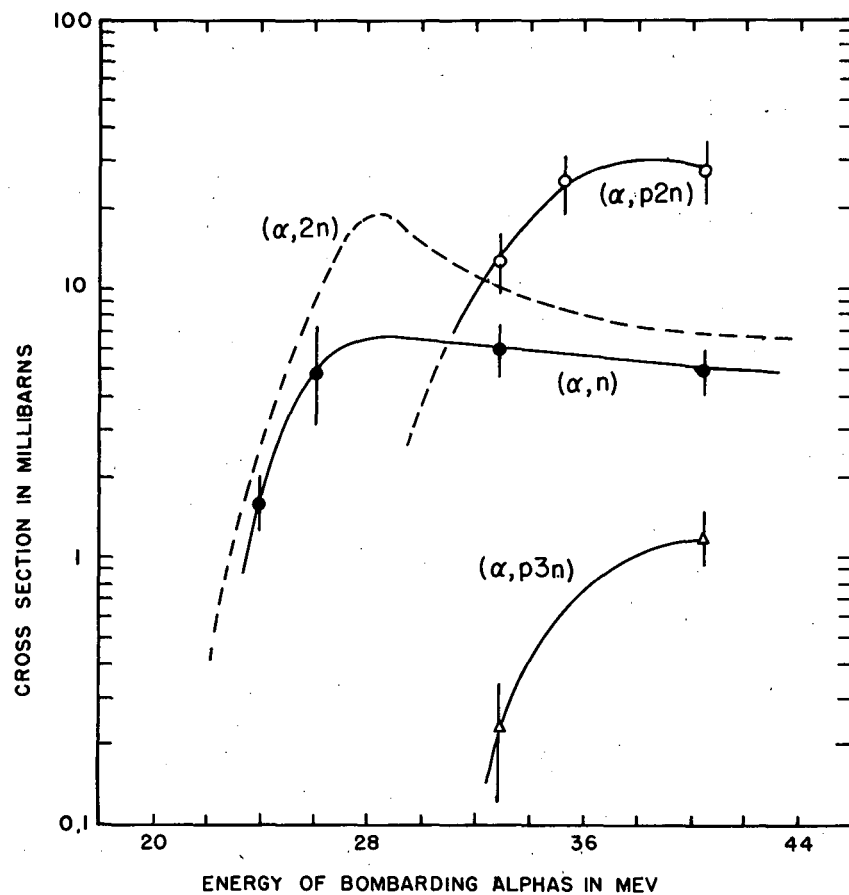

MU-11704

Fig. 14. Excitation functions for some (α, xn) and (α, pxn) reactions on Cm²⁴⁴.

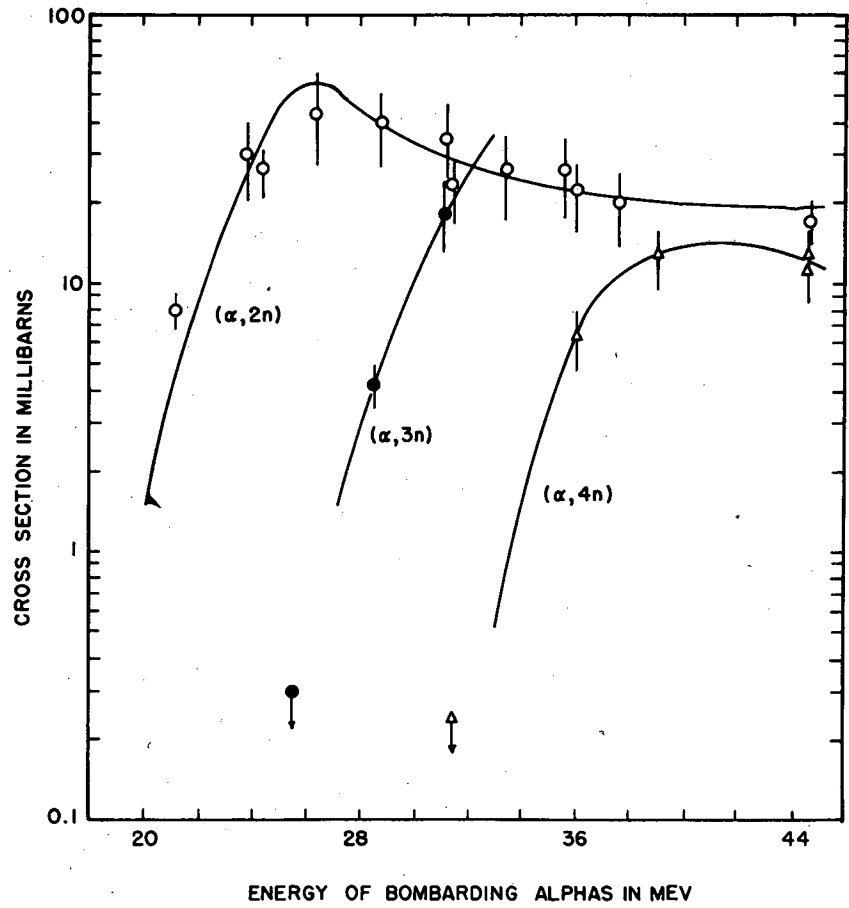

MU-11705

Fig. 15. Excitation functions for some (α, xn) reactions on Am^{243} .

of the berkelium fractions. Cross sections were calculated by use of the measured alpha disintegration rates and the appropriate branching ratios. Owing to the small alpha branching of Bk^{244} and the close similarity of its alpha-particle energy to that of the highest-energy alpha group of Bk^{243} , alpha particles of Bk^{244} can be distinguished readily only in those bombardments in which little or no Bk^{243} is produced. Consequently, no measurements of the $(\alpha, 3n)$ cross section above 31 Mev were obtained.

3. Helium ions on Americium-241 and Curium-242

Several isolated measurements have also been made on cross sections for similar reactions on Cm^{242} and Am^{241} . Although complete data are by no means available, preliminary results indicate that cross sections for the $(\alpha, 2n)$ reactions on these isotopes are one-third to one-half as large as cross sections at the same energy for the heavier isotopes Cm^{244} and Am^{243} . No information was obtained on the (α, pxn) reaction types for Am^{241} or Cm^{242} .

C. Summary of Results

Although the data presented are incomplete in many respects, they have proved useful in the preparation and identification of berkelium and californium isotopes. In addition, however, a number of extremely interesting features of excitation functions in the heavy-element region are illustrated. Among these features, three deserve particular mention.

First, the total spallation cross sections observed in americium, curium, and other heavy elements are reduced to a fraction of the total geometric cross section by competition with the fission process. Secondly, proton-emission products compete very favorably with neutron-emission products in spite of the Coulomb barrier toward proton emission. Finally, the pronounced high-energy tail observed in the (α, xn) excitation functions for the heaviest elements has no obvious counterpart in similar excitation functions on lighter target isotopes, of which the work of Kelly and Segrè on bismuth is an example.³³ No simple explanation of these phenomena is available, but a number of interesting suggestions have been made by Seaborg, Glass, Carr, and Cobble.³⁴

V. NUCLEAR PROPERTIES OF BERKELIUM AND CALIFORNIUM ISOTOPES

A. Berkelium Isotopes

1. Berkelium-243

Thompson, Ghiorso, and Seaborg² discussed the preparation and properties of berkelium-243 in their paper on the discovery of the element. These authors reported the half life, complex alpha spectrum, alpha-to-electron-capture branching ratio, and mass assignment of Bk^{243} made by the bombardment of Am^{241} with helium ions. Much of this work was repeated by Hulet,⁶ using isotopically pure Bk^{243} from the (d,n) reaction on Cm^{242} , with substantially identical results. The best values for the half life and alpha branching from this work were taken to be $4.5 \pm .1$ hours and 0.15% respectively.

Berkelium-243 for the investigations described herein was obtained either from the (α , 2n) reaction on Am^{241} or from the (α , 4n) reaction on Am^{243} . When the latter method of preparation was used the ratio of Bk^{243} to Bk^{244} could be varied over wide limits (as shown in the excitation function of Fig. 16), permitting the resolution of Bk^{243} and Bk^{244} radiations from one another. Berkelium from the Am^{241} bombardments, however, contained larger amounts of Bk^{243} per unit amount of target material and was free of heavier berkelium isotopes.

Electromagnetic radiations of Bk^{243} were examined by scintillation spectrometer techniques in samples prepared by the Am^{241} (α , 2n) Bk^{243} reaction. The activity of these preparations was due about 70% to Bk^{243} and about 30% to Bk^{244} , with little or no contribution from the other berkelium isotopes. The separated berkelium fractions were prepared for use by evaporation on 0.001-inch aluminum foil from solutions of concentrated nitric acid.

In the gamma spectrum of these mixtures, 200-, 740-, 840-, 900-, 960-kev, and several higher-energy gamma rays were observed together with K and L x-rays. Subtraction of the known spectrum of Bk^{244} and comparison of coincidence spectra of these samples with similar spectra of Bk^{244} permitted the assignment of the 740-, 840-, and 960-kev radiation to Bk^{243} . The gamma spectrum of Bk^{243} in this energy region (after subtraction of the Bk^{244} contribution) is shown in Fig. 16. Most of the radiation remaining at lower energies is accounted for by

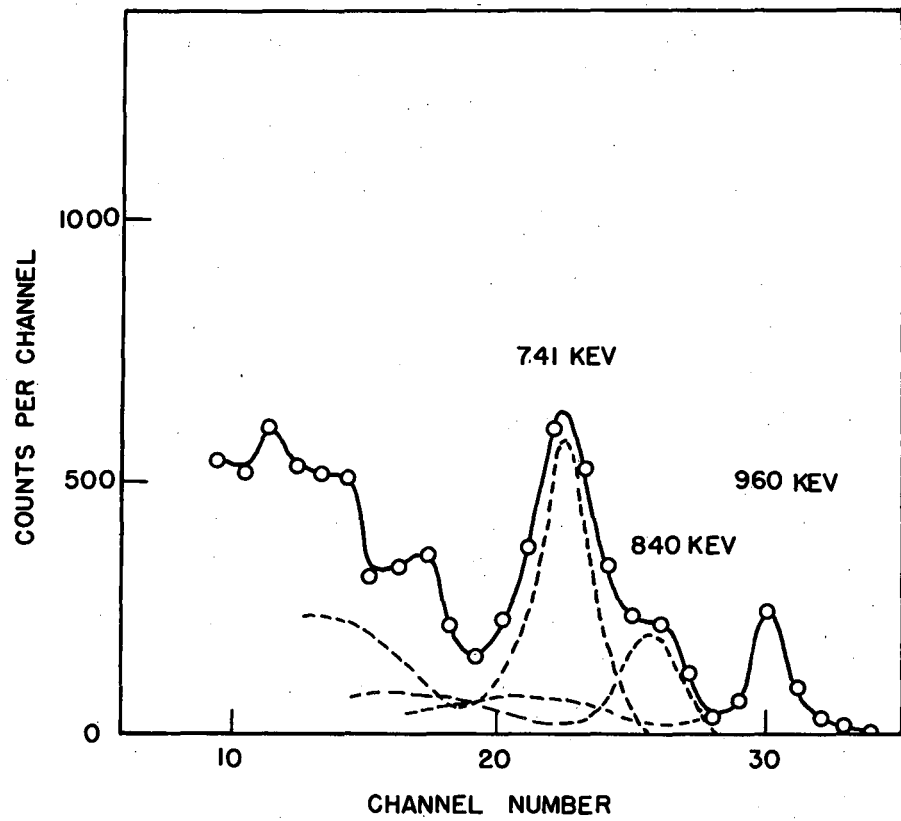

MU-11706

Fig. 16. Gamma spectrum of Bk²⁴³ in the 500-1000-kev region.

the Compton distribution from the indicated gamma rays; however, other radiation may be present in low intensity but unresolved in these experiments. The energies and corrected relative intensities of three gamma rays assigned to Bk²⁴³ are given in Table II. All three gamma rays decayed with the 4.5 ± 0.3 -hour half life of Bk²⁴³.

Table II

Gamma rays of berkelium-243	
<u>Radiation</u>	<u>Corrected Relative Intensity</u>
740 \pm 40 keV	1.0
840 \pm 40 keV	0.3
960 \pm 40 keV	0.3

With the limited information available little can be said about the decay scheme of this isotope. It is clear, however, that a cascade arrangement of any two of the observed gamma rays is precluded by the 1.5 Mev of decay energy available.³⁰

It was also of interest to examine the alpha-decay scheme of Bk²⁴³ from these sources. The energies, abundances, and assignment of the alpha groups reported by Thompson et al.² were confirmed in numerous bombardments of Am²⁴¹ as well as in the excitation-function experiments on the target nucleus Am²⁴³. Alpha groups of $6.72 \pm .02$ Mev (30%), $6.55 \pm .02$ Mev (53%), and $6.20 \pm .02$ Mev (17%) were observed as reported.

The electromagnetic spectrum associated with the alpha decay of Bk²⁴³ was studied by use of a zinc sulfide detector for alpha particles in the coincidence equipment. In addition to americium K x-rays, gamma rays of 536, 187, 146, and 42 keV were observed in coincidence with alpha particles (Fig. 17). The energies and intensities of these radiations, after correction for geometry, counting efficiency, and a small contribution to the alpha activity due to Bk²⁴⁴, are given in Table III.

Table III

Electromagnetic radiation in the alpha decay of berkelium-243	
<u>Radiation</u>	<u>Abundance per alpha disintegration</u>
536 \pm 10 keV	0.10
187 \pm 3 keV	0.34
146 \pm 5 keV	0.08
K x-rays	0.09
42 \pm 3 keV	0.04

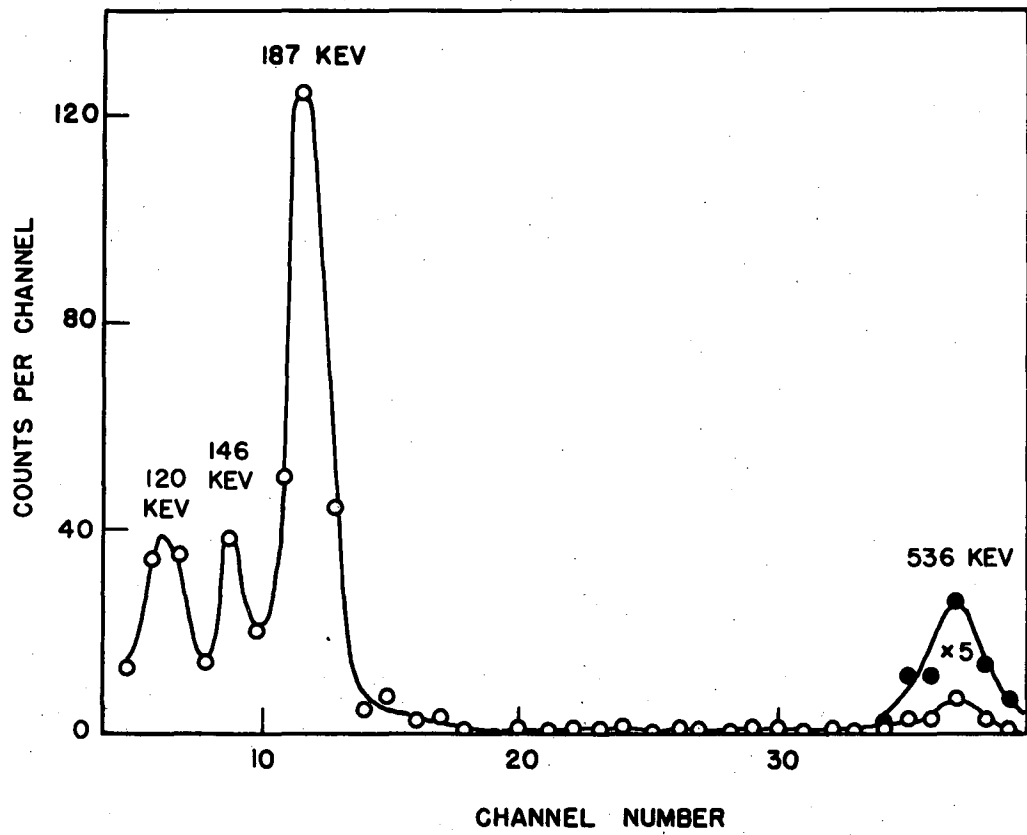

MU-11707

Fig. 17. Gamma spectrum in coincidence with alpha particles of Bk^{243} .

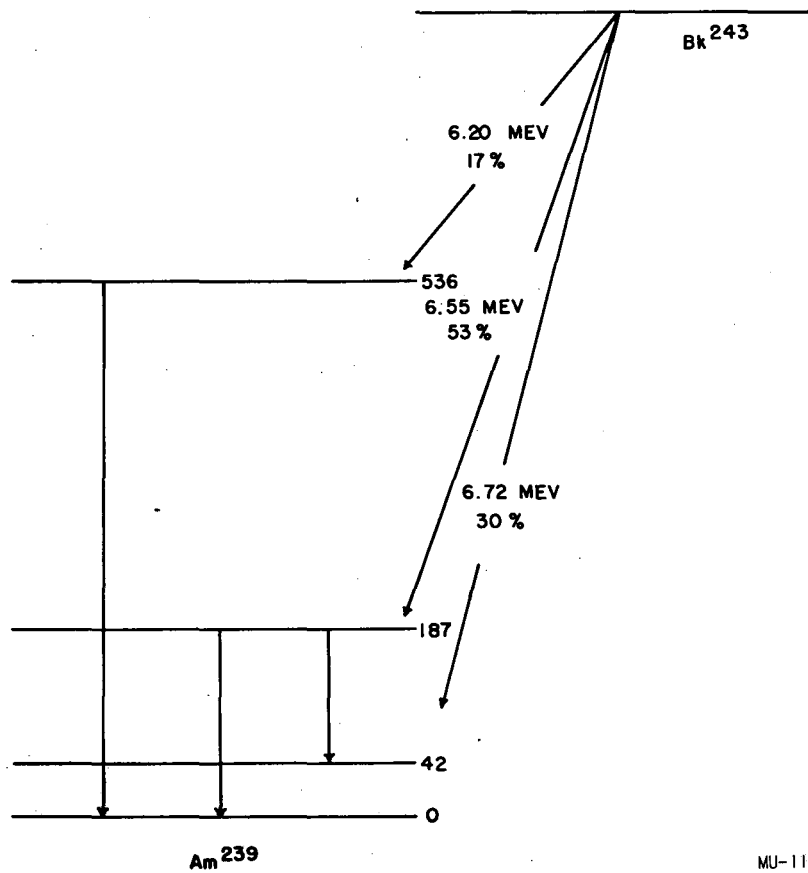

MU-11708

Fig. 18. Alpha-decay scheme of Bk^{243} .

These data, together with the alpha-particle energies, are incorporated in the decay scheme shown in Fig. 18. The placement of the 536- and 187-kev transitions agrees well with the alpha-particle spectra. The placement of the 146-kev transition is subject to some uncertainty; however, the arrangement indicated is preferred by analogy with other heavy-element decay schemes. Rotational levels corresponding to those indicated at ~40 kev are a common occurrence in this region.³⁵⁻³⁷

2. Berkelium-244

Hulet⁶ obtained indirect evidence for the production of Bk²⁴⁴ along with Bk²⁴³ in the bombardment of Am²⁴¹ with helium ions by comparison of the curium decay products of such a bombardment with the curium fraction from the decay of isotopically pure Bk²⁴³. Since the berkelium from both sources decayed with the same apparent half life, it was suggested that Bk²⁴⁴ decayed primarily by electron capture with a half life very similar to that of Bk²⁴³. Abundant confirmation of this hypothesis was obtained in this work.

Berkelium-244 was prepared free of Bk²⁴³ by bombardment of Am²⁴³ with helium ions several Mev below the threshold for the Am²⁴³ (α , 4n) Bk²⁴³ reaction. The berkelium fraction from this bombardment contained Bk²⁴⁶ (1.9-day), Bk²⁴⁵ (5.0-day), and a new activity decaying principally by electron capture with a half life of $4.35 \pm .15$ hours. The new activity was assigned to Bk²⁴⁴ on the basis of the following arguments. First, the 5.79-Mev alpha particles of Cm²⁴⁴ were observed to grow into the separated berkelium fraction in amounts consistent with the observed activity of the new isotope. Secondly, although a detailed excitation function for the production of the 4.35-hour activity was not carried out, the alpha particles and gamma rays associated with this activity were observed in bombardment of Am²⁴³ with helium ions at energies above the (α , 3n) threshold but not below this threshold. Finally, the radiations of Bk²⁴⁴ were seen in berkelium made by the bombardment of Am²⁴¹ with helium ions of various energies. The only assignment consistent with all these observations is to mass 244.

Electromagnetic radiations from Bk²⁴⁴ were studied both in mixtures with Bk²⁴³ and in mixtures with Bk²⁴⁵ and Bk²⁴⁶. Essentially identical results were obtained in either case. The spectrum of Bk²⁴⁴ is extremely

complex; however, its principal features are two intense gamma rays of 200 and 900 kev and higher-energy radiations of lower intensity extending to 1.7 Mev. In the region from 0.9 to 1.7 Mev no fewer than seven distinct photon energies were observed with the energies and intensities given in Table IV. All the gamma rays except the one at 1.72 Mev decayed

Table IV

High-energy gamma rays in the electron-capture decay of Bk^{244}	
<u>Photon</u>	<u>Relative intensity</u>
0.900 Mev	1.0
1.06 Mev	0.07
1.16 Mev	0.11
1.23 Mev	0.05
1.37 Mev	0.007
1.50 Mev	0.02
1.72 Mev	0.002

with a 3- to 5-hour half life consistent with their assignment to Bk^{244} . Counting statistics on the 1.72-Mev gamma were too poor to yield a meaningful half life; however, this radiation was observed in coincidence with K x-rays and therefore assigned to Bk^{244} , since the other berkelium isotopes that could also have been present have insufficient decay energy to populate such a level by K capture.³⁰

Coincidence experiments showed that the 200-kev and the 900-kev radiations were in coincidence, with abundances of roughly 0.6 200-kev gamma per 900-kev gamma and about 1.0 900-kev gamma per 200-kev gamma. These data suggest that the 200-kev transition lies above the 900-kev gamma, although a somewhat stronger argument for this arrangement could be based on the complete absence of nonrotational levels several hundred kev above the ground state in any even-even nucleus investigated in the heavy-element region.²⁷ Comparison with the somewhat similar decays of Bk^{246} and E^{250} also support this choice.

Although it is clear that a complete decay scheme for Bk^{244} cannot be inferred from the data given here, the salient features of its decay are summarized in the partial -- and highly tentative -- scheme of Fig. 19. The decay of the 900-kev gamma to a 2+ level has been indicated solely in analogy with the decay of Bk^{246} , as discussed later. No attempt has been made to assign the high-energy transitions observed or

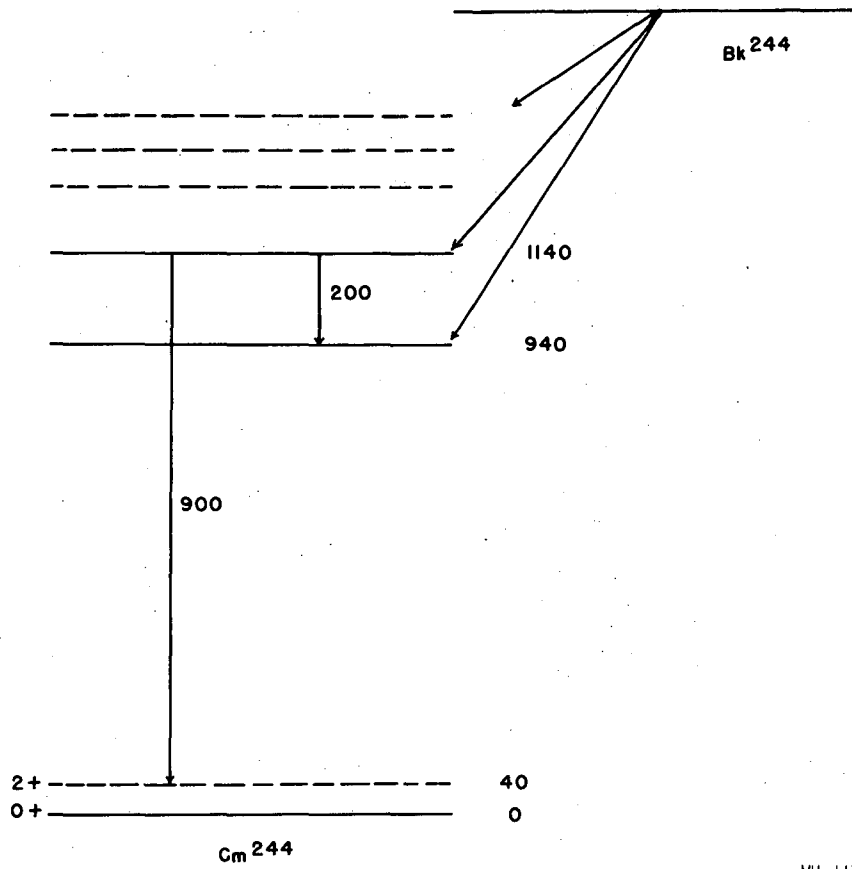

MU-11709

Fig. 19. Tentative and partial electron-capture decay scheme of Bk^{244} .

the low-intensity transitions that may be present at 490 and 630 kev.

Alpha particles of energy 6.67 Mev were also detected in the berkelium fractions containing only Bk^{244} , Bk^{245} , and Bk^{246} . The decay of this alpha activity was followed over several half lives and found to exhibit a half life identical with that of Bk^{244} . Further bombardments of Am^{243} at several energies established the parallel behavior of the 6.67-Mev alpha particles and the gamma rays characteristic of Bk^{244} , thus providing strong evidence for the assignment of these alpha particles to this isotope.

An accurate determination of the alpha-particle energy of Bk^{244} was made by comparison with the alpha groups from E^{253} in a gridded ionization chamber and pulse-height analyzer. With the E^{253} alpha-particle energy of 6.642 Mev determined by the alpha-particle spectrograph as a standard,³⁸ the Bk^{244} alpha energy was found to be $6.67 \pm .0015$ Mev. This alpha group was taken to be the ground-state transition with reference to alpha-decay systematics³⁹ and the alpha-decay energies of neighboring berkelium isotopes. No evidence for complex alpha decay was obtained.

An alpha-to-electron-capture branching ratio was determined roughly from the amount of Cm^{244} resulting from the decay of Bk^{244} and the observed Bk^{244} alpha activity. On the assumption that no other alpha groups were present in significant intensity in the decay of Bk^{244} , a ratio of 6×10^{-5} alpha decay per electron capture decay was found. This corresponds to a partial alpha half life of 8 ± 3 years, in good agreement with the value predicted from alpha systematics.³⁹

3. Berkelium-245

Hulet et al.^{5,6} investigated the properties of Bk^{245} in some detail and reported its 5.0-day half life, complex alpha decay, branching ratio, and gross gamma spectrum. The assignment of this activity to Bk^{245} was based on cross-bombardments of Cm^{242} , Cm^{244} , Am^{241} , and Am^{243} , and on the Cm^{245} decay product identified later. Much of this work has been confirmed in the investigation reported here, and a detailed study of the electron capture and alpha-decay schemes of this isotope has been made.

Berkelium-245 is conveniently prepared by the $\text{Am}^{243} (\alpha, 2n) \text{Bk}^{245}$

or Cm²⁴⁴ (α , p2n) Bk²⁴⁵ reaction. Either method results in a mixture of Bk²⁴⁵ and Bk²⁴⁶ in roughly comparable amounts, and both types of bombardments were employed in this work with similar results.

The electromagnetic radiations accompanying electron capture in Bk²⁴⁵ were examined, with coincidence equipment and scintillation detectors as before. In addition to K and L x-rays, two gamma rays, with energies 252 ± 3 and 380 ± 5 kev, were found in the spectrum of Bk²⁴⁵. After carefully calibrating of the equipment and the taking of precautions to prevent the simultaneous arrival in the crystal of more than one photon, the intensities of the electromagnetic radiations shown in Table V were determined.

Table V

Electromagnetic radiation in the electron-capture decay of Bk ²⁴⁵	
Radiation	Relative intensity
K x-rays	1.0
252 ± 3 kev	0.26
380 ± 5 kev	0.037

An extended series of coincidence experiments was next carried out in order to further investigate this decay. The radiations coincident with K x-rays, the 252-kev gamma ray, and the 380-kev gamma ray were examined, and accurate intensities, corrected for geometry, absorbers, and counting efficiencies, were obtained. These data are summarized in Table VI.

Table VI

Coincidence measurements on Bk ²⁴⁵ electron-capture decay			
Gate	K x-ray	252-kev	380-kev
K x-rays	0.73*	0.21*	0.03*
252-kev	0.70		0.038
380-kev	0.68*	0.30	

* These abundances have not been corrected for the loss of K x-rays due to the simultaneous arrival of two or more K x-rays in the detecting crystal.

Because the samples used for these measurements usually contained various amounts of Bk²⁴⁶, most of the measurements were repeated after further decay in order to minimize the effects of the Bk²⁴⁶. In some

cases, corrections were made for the contribution of Compton or photo-peaks from Bk^{246} to the observed spectra.

Finally, an experiment was carried out in which the electron spectrum in coincidence with K x-rays was observed with an anthracene scintillation crystal. An electron line at about 127 keV was found in coincidence with about 80% of the K x-rays, corresponding to the expected K-conversion line of the 252-keV photon. An L + M + N line (with some possible contribution from the K line of the 380-keV transition) was also observed.

The conversion coefficients for the 252-keV gamma calculated from the above data are 1.9 and 2.3 for K and total conversion respectively. This was determined by coincidence measurements of the 252-keV gamma with the K x-ray and with the 380-keV gamma. These data are shown in Table VII together with the theoretical values of Sliv⁴⁰ and Rose.⁴¹

Table VII

Conversion coefficients of the 252-keV transition in Bk^{245}					
	E1	E2	E3	M1	Experimental
α K	0.05	0.10	0.24	1.83	1.9
α T	0.06	0.4	3.1	2.3	2.3

The agreement with the theoretical conversion coefficient for a pure M1 transition is extremely good; however, the uncertainties in the experimental values would allow as much as 15% E2 admixture.

A decay scheme suggested by these results and consistent with most of the data derived from other isotopes that decay to Cm^{245} is shown in Fig. 20. The electron-capture decay energy corresponding to this scheme must be at least 0.76 MeV for K capture to occur to the 632-keV level, a value entirely consistent with the calculated energy of 0.80 MeV.³⁰

The Cf^{249} alpha decay scheme shown in Fig. 20 represents the data from Stephens²⁷ together with the alpha groups found by Ghiorso.⁴² It should be noted that the 395-keV gamma transition in this decay is not identical with the 380-keV transition observed in Bk^{245} decay. Unfortunately, because of the similarity in gamma energy, it would have been difficult to detect a small alpha branching to the 630-keV level.

Fields et al.⁴³ have reported photons of about 121 and 160 keV in the beta decay of Am²⁴⁵. The radiations were also seen by Browne and coworkers,⁴⁴ who observed K and L conversion lines from a photon of 255 keV in the decay of Am²⁴⁵. No other correspondence obtains, however, between the decay scheme presented by Browne et al. and the decay scheme of Fig. 22.

Since Bk²⁴⁵ decays ~0.1% by alpha emission, it was also possible to examine the gamma spectrum in coincidence with alpha particles from this source. Photons of 110, 164, 206, and 480 keV were seen in these experiments, with the corrected intensities given in Table VIII. These intensities were followed over several half lives without significant change, and consequently were thought to be little affected by the possible (but unobserved) alpha decay of Bk²⁴⁶.

Table VIII

Electromagnetic radiation in the alpha decay of Bk ²⁴⁵	
Photon energy	Photons per alpha
K x-rays	0.11
164 ± 5 keV	0.07
206 ± 3 keV	0.28
480 ± 5 keV	0.18

These results are incorporated in the decay scheme of Fig. 21. The alpha-particle energies and abundances are the best values from this experiment and are in fair agreement with the energies and intensities reported by Hulet et al.⁵ Also shown is the electron-capture decay scheme for Cm²⁴¹ reported by Glass.⁴⁵ His level assignments are consistent with those derived from this work, with the exception of the 600-keV level. It has been suggested that the 600-keV photon observed in the decay of Cm²⁴¹ might have been due to the simultaneous arrival in the crystal detector of the 480-keV gamma and K x-rays. On the other hand, alpha population to a 600-keV level would be expected to be very small and might well have escaped detection.

Some uncertainty is again involved in the placement of the 164-keV transition. The choice was made largely because of the reasonableness of a 42-keV state comprising part of a rotational band, as observed in many other nuclei in this region and as discussed in the similar case of Bk²⁴³.

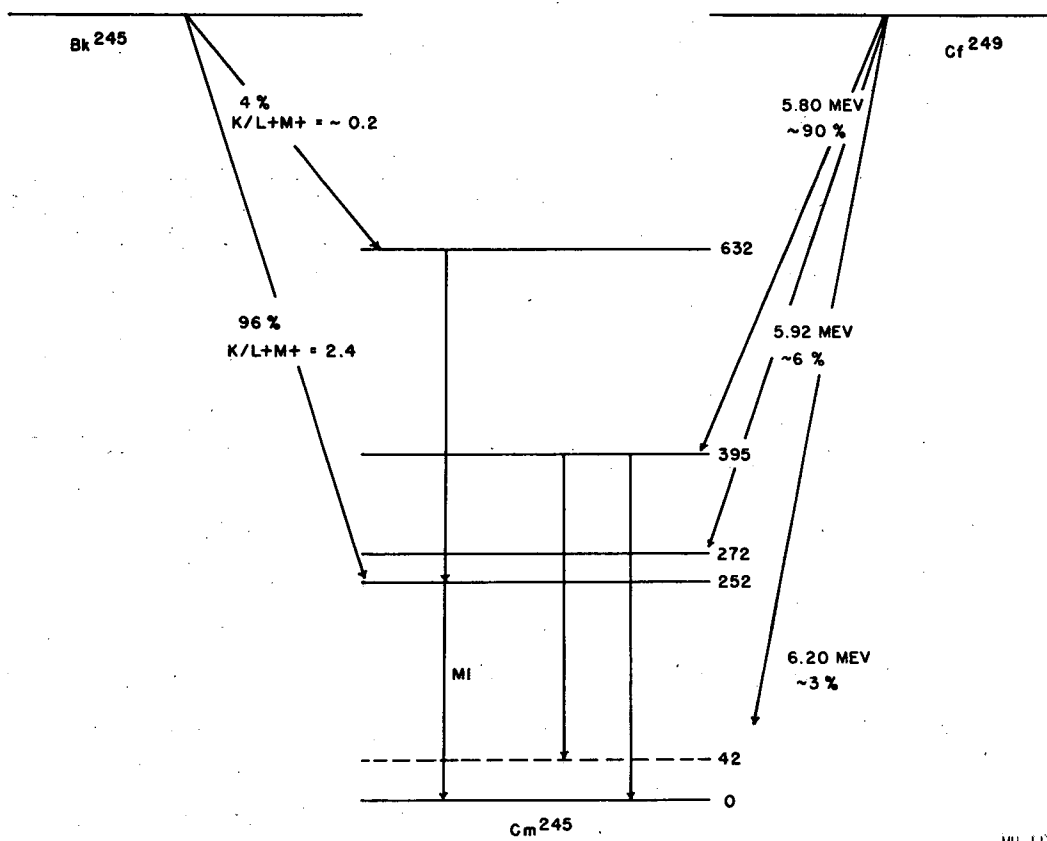

MU-11710

Fig. 20. Electron-capture decay scheme of Bk^{245} .

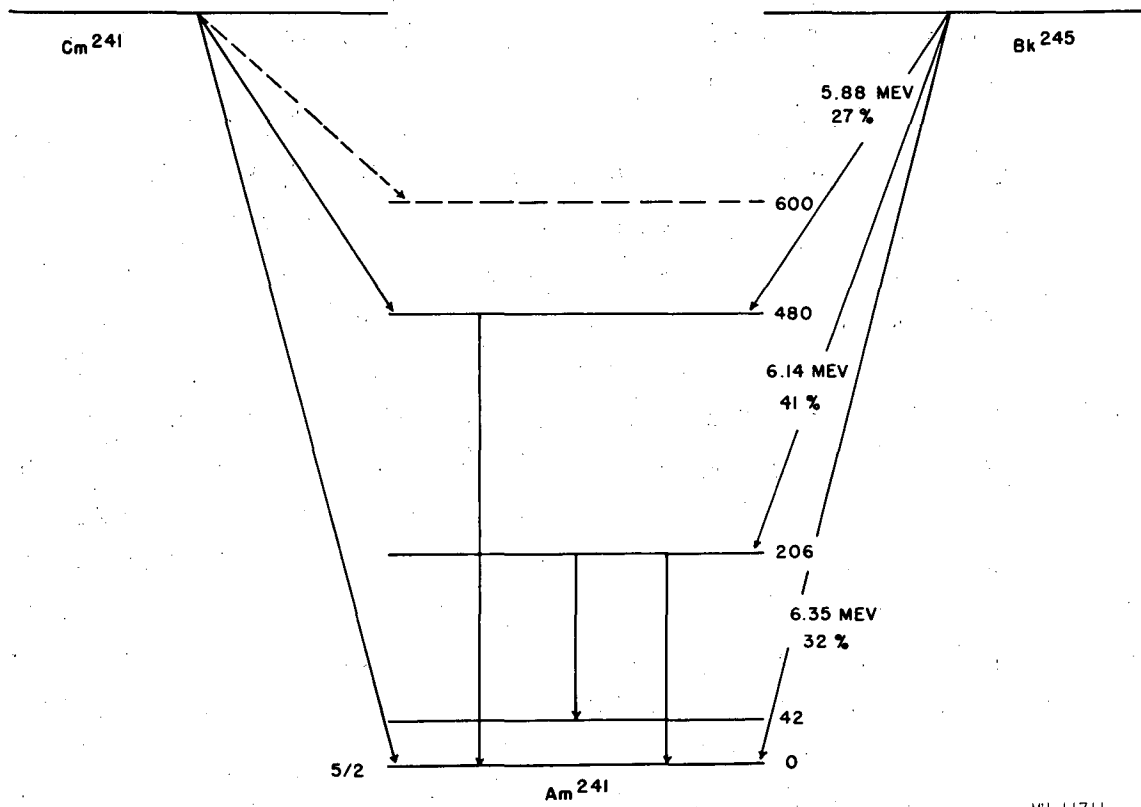

MU-11711

Fig. 21. Alpha decay scheme of Bk^{245} .

4. Berkelium-246

The 1.8-day half life of Bk^{246} was reported by Hulet et al.^{6,7} along with observations of an abundant 800-keV gamma ray in its gamma spectrum. While little doubt attaches to the identity of this isotope, no conclusive mass assignment has been made as yet.

Berkelium-246 for these investigations was prepared both by the $\text{Cm}^{244} (\alpha, pn) \text{Bk}^{246}$ and by the $\text{Am}^{243} (\alpha, n) \text{Bk}^{246}$ reactions. Yields were somewhat higher per unit amount of target in the latter reaction; however, the isotopic purity of the product is not markedly different in either case. Practical considerations of ease of separation from the target material and the availability of Am^{243} make this route the more desirable, however.

Since the 5-day Bk^{245} was always present together with the 5-day Bk^{246} , the gamma spectroscopy of these two isotopes was carried out simultaneously. Examination of the region from 200 to 400 keV always required consideration of the radiations of Bk^{245} , and made the resolution of low-intensity gamma rays of Bk^{246} rather uncertain. A typical spectrum of the mixture of isotopes is shown in Fig. 22. Careful comparison of the 800-keV gamma ray with standards demonstrated that the observed peak was due to a single gamma ray (>95%); however, a similar comparison with the 1.09-MeV peak revealed a complex structure, which was resolved as shown in Fig. 23. This resolution was further supported by L x-ray-gamma coincidence spectra. It was, however, not necessarily the only resolution consistent with the data. Other likely resolutions led to essentially equivalent results except for the relative intensities of the three components.

The decay scheme for Bk^{246} shown in Fig. 24 was suggested by an extended series of coincidence measurements on this isotope. From the intensities of the K and L x-rays in coincidence with the 800-keV gamma ray, a K-to-L capture ratio to the level of about 3 was determined together with a value for the total L vacancies per 800-keV photon of about 1.8. The excess L vacancies (~1 per 800-keV gamma) may be explained readily in terms of an assumed decay to the second member of the ground-state rotational band observed⁴⁶ in the Cm^{246} nucleus from the alpha decay of Cf^{250} and indicated in Fig. 26. The subsequent

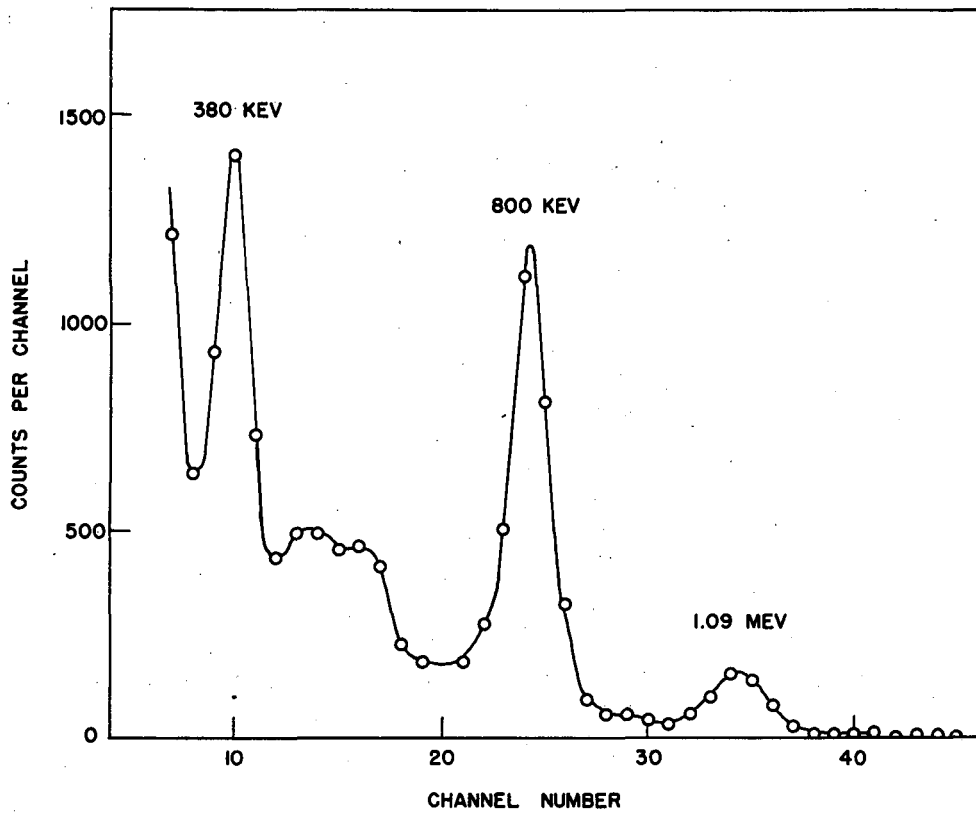

MU-11712

Fig. 22. Gamma spectrum of Bk^{245} and Bk^{246} .

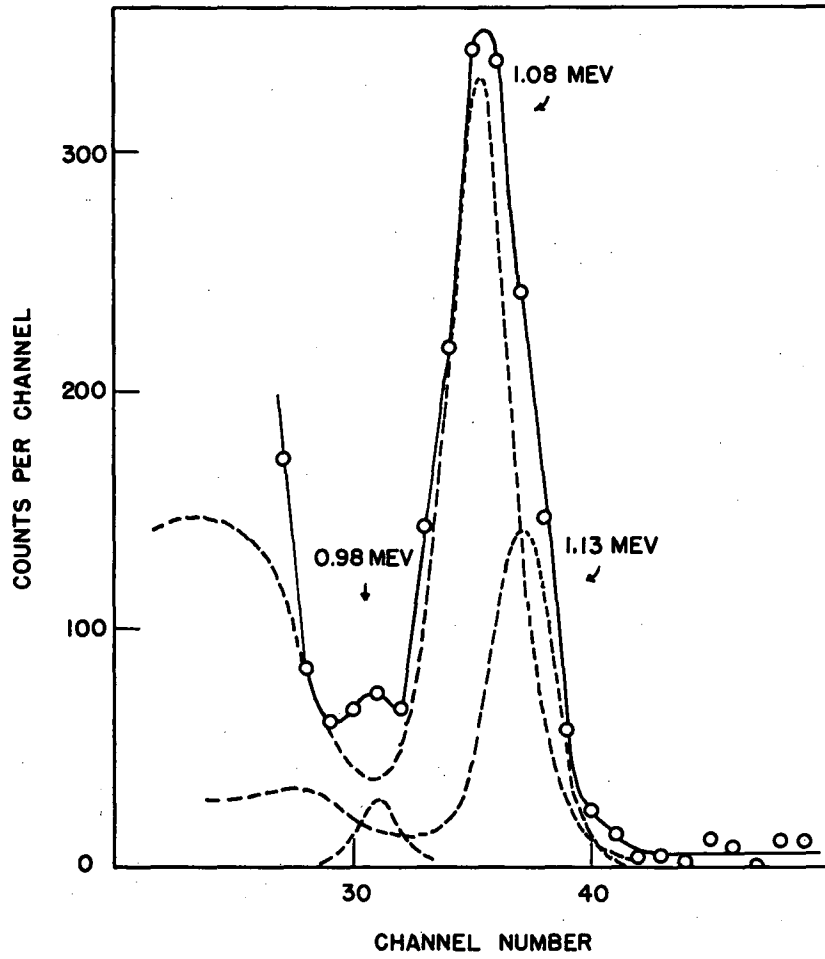

MU-11713

Fig. 23. Resolution of 1.09-Mev peak of Bk²⁴⁶.

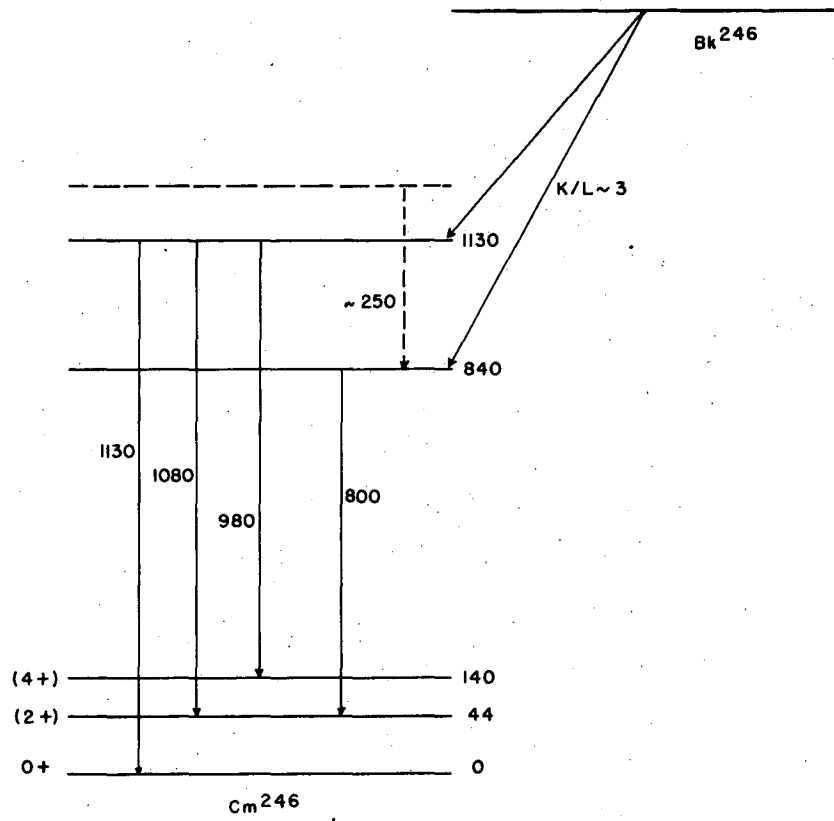

MU-11714

Fig. 24. Tentative and partial electron-capture decay scheme of Bk^{246} .

transition is commonly of the E2 type, exhibiting very large L conversion coefficients.

Similar reasoning applies to the gamma triplet observed at about 1.02 Mev. In coincidence with L x-rays, the lower-energy components were definitely enhanced relative to their intensities in the gross gamma spectrum, implying L-converted coincident transitions. The energies of the three gamma rays agree well with those expected for the decay to rotational levels based on the ground state.³⁵ A very similar complex group at about 1.04 mev has been observed by Asaro⁴⁷ in the decay of Bk²⁵⁰.

Low-intensity radiation of ~250 kev was also observed in coincidence with the 800-kev gamma ray of Bk²⁴⁶, in insufficient intensity, however, to lie below the 800-kev transition without invoking unreasonably large conversion coefficients. The assignment of the 250-kev gamma ray is indicated by the dashed line in the decay scheme.

Although the above data are subject to several other interpretations, those outlined here are felt to represent the extant data well within the framework of other knowledge derived from a variety of sources on the level patterns of similar nuclei.

5. Berkelium-247

Attempts to prepare this isotope were made with the first few micrograms of Cm²⁴⁴ that became available in 1952.⁶ A continuing series of bombardments succeeded only in setting lower and upper limits to the half life of the unobserved activity.

From closed-cycle calculations³⁰ only 40 kev were estimated to be available for the electron-capture decay of Bk²⁴⁷; however, it seemed worth while to investigate the remote possibility of a short half life for this isotope in view of the failure of previous experiments. Accordingly, a helium-ion bombardment of Cm²⁴⁴ was carried out in which the Cf²⁴⁷ and Cf²⁴⁶ were isolated soon after the end of bombardment. After the 2.4-hour Cf²⁴⁷ had been allowed to decay through one half life, the californium fraction was quickly milked for berkelium activity. No activity was found in the berkelium fraction and it was concluded from the times and activities involved that the Bk²⁴⁷ half life must lie outside the region 4-min to 3.5-yr.

Following this experiment, which effectively ruled out the possibility of a half life shorter than many years, a large target containing ~100 micrograms of Cm²⁴⁴ containing ~2% Cm²⁴⁵ and ~3% Cm²⁴⁶ was bombarded for ~30 hours with an intense helium-ion beam of about 28-Mev. After the decay of the Cf²⁴⁷ was allowed for, the berkelium fraction was separated and set aside for several months to allow for the decay of Bk²⁴⁵ (5 days). Following this decay period a small amount of Cf²⁵² was added to serve as a chemical yield tracer, and the berkelium fraction was subjected to intensive purification procedures to free it from the curium alpha activity. Finally the berkelium was separated from the californium tracer in two successive steps by the elution from Dowex-50 cation-exchange resin with ammonium α -hydroxy isobutyrate. The elution curve for this final separation is shown in Fig: 25.

Activity was observed in the berkelium position with both a windowless proportional counter (~15 counts/min) and the alpha pulse analyzer (~0.3 counts/min). Both types of activity were found to peak at the elution position expected for berkelium, and hence were distinguished from background contamination in reagents or counting instruments.

Examination of the berkelium sample with a sodium iodide scintillation crystal and a xenon-filled proportional counter failed to indicate the presence of K or L x-rays. Although the possibility of pure M (or higher) capture by Bk²⁴⁷ exists, K or L x-rays in amounts corresponding to the observed proportional counter activity would have been observed easily. The most reasonable explanation for the activity observed with the windowless proportional counter ascribes this activity to Bk²⁴⁹, (280 d, 0.09-Mev β^-) formed by the (α , n) reaction on the Cm²⁴⁶, which was present in the target material in 3% abundance. If the cross section for this reaction is equal to the cross section for the (α , n) reaction on Cm²⁴⁴, the observed proportional counter activity can be accounted for in toto. It was concluded that no evidence was obtained for electron capture in Bk²⁴⁷.

Examination of the 0.7 disintegrations per minute of alpha activity found in the berkelium position revealed at least three alpha groups of energies 6.66, 5.50, and 5.30 Mev, as shown in the alpha-particle spectrum of Fig. 26. Accurate determination of the relative intensities of the alpha groups was made very difficult by the low counting rates

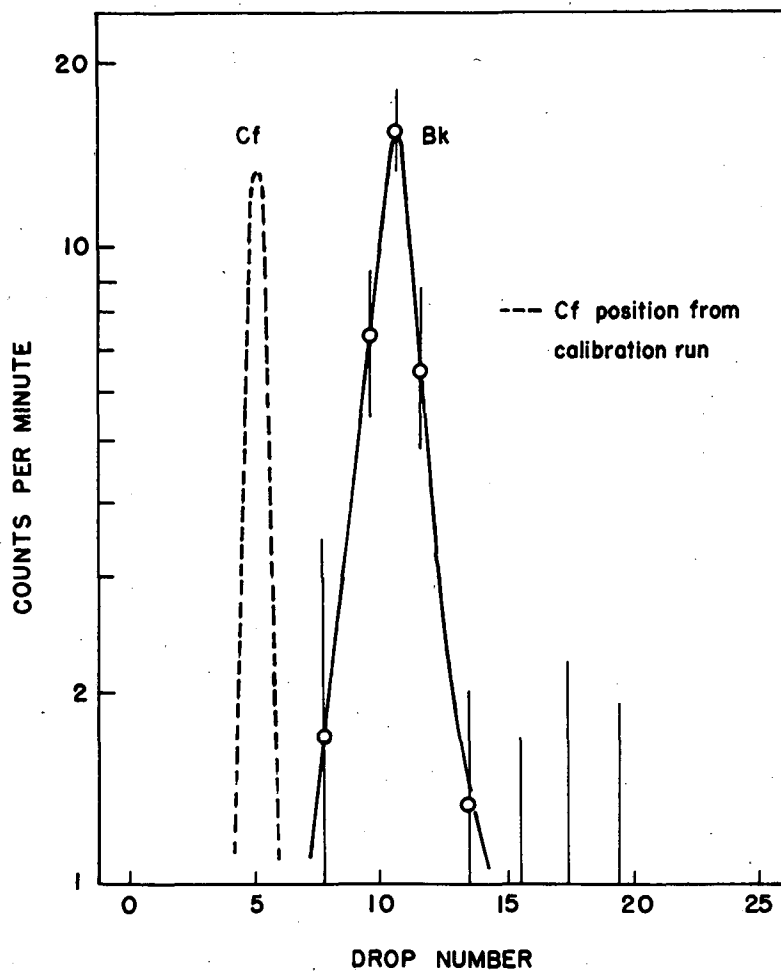

MU-11715

Fig. 25. Elution curve of final separation of Bk²⁴⁷.

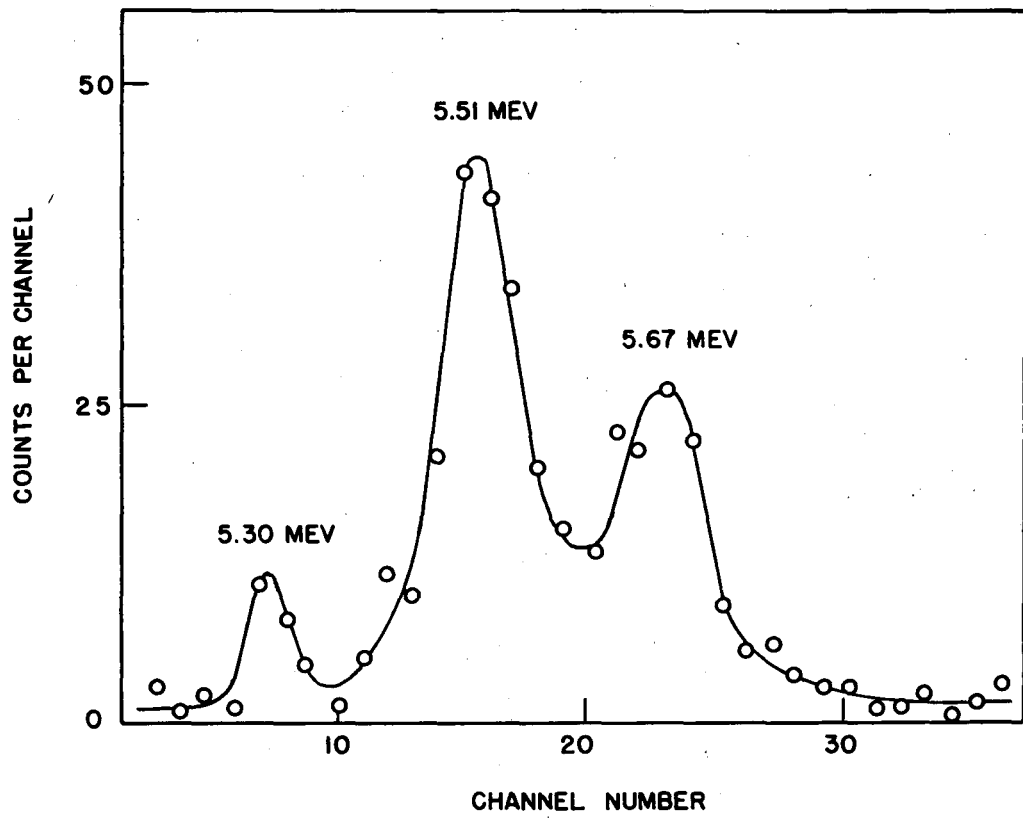

MU-11716

Fig. 26. Alpha-particle spectrum of Bk²⁴⁷.

obtained. The best values, however, are shown in Table IX. The 5.40-Mev alpha particles of the Bk²⁴⁹ contaminant would not have been observed in these experiments, owing to the low alpha branching (10⁻³%) of the isotope and the small amounts present in the Bk²⁴⁷.

Table IX

Alpha particles of Bk ²⁴⁷	
Energy (Mev)	Abundance %
5.30 ± .05	5
5.51 ± .03	58
5.67 ± .03	37

In view of the similarity in alpha-particle energy between the main group of the new berkelium isotope and that of Pu²³⁸ (5.50 Mev), several separations of berkelium were carried out in which plutonium would have been removed. After these procedures, the alpha spectrum of the berkelium fraction was again examined and found unchanged. The proportional-counter activity ascribed to Bk²⁴⁹ was found again in the same abundance relative to the new alpha activity. These experiments provide conclusive chemical identification of the new isotope.

The similarity in structure of the alpha groups observed in those of other odd-mass berkelium isotopes made it desirable to carry out alpha-gamma coincidence experiments on the Bk²⁴⁷. In coincidence with the alpha particles, K x-rays and gamma rays of 84 ± 3 kev and 265 ± 10 kev were observed in corrected abundances of about 0.2, 0.4, and 0.3 per alpha decay. The alpha-decay scheme that follows from these observations and the alpha spectrum is shown in Fig. 27. No evidence for other transitions was obtained, although gamma radiation from the 460-kev state inferred from the alpha spectrum would not have been observed owing to the low alpha population of this level and the reduced detection efficiencies for 460-kev gamma radiation. Similarly, a 220-kev gamma ray expected by analogy to Bk²⁴³ and Bk²⁴⁵, would have escaped detection at these counting rates.

The decay scheme shown is in good agreement with the data of Stephens and Asaro⁴⁸ and Engelkemeir et al.⁴⁹ on the decay of Pu²⁴³ by beta emission, which is also indicated in Fig. 27. In particular, the placement of the 84-kev level is supported by this work. The accurate

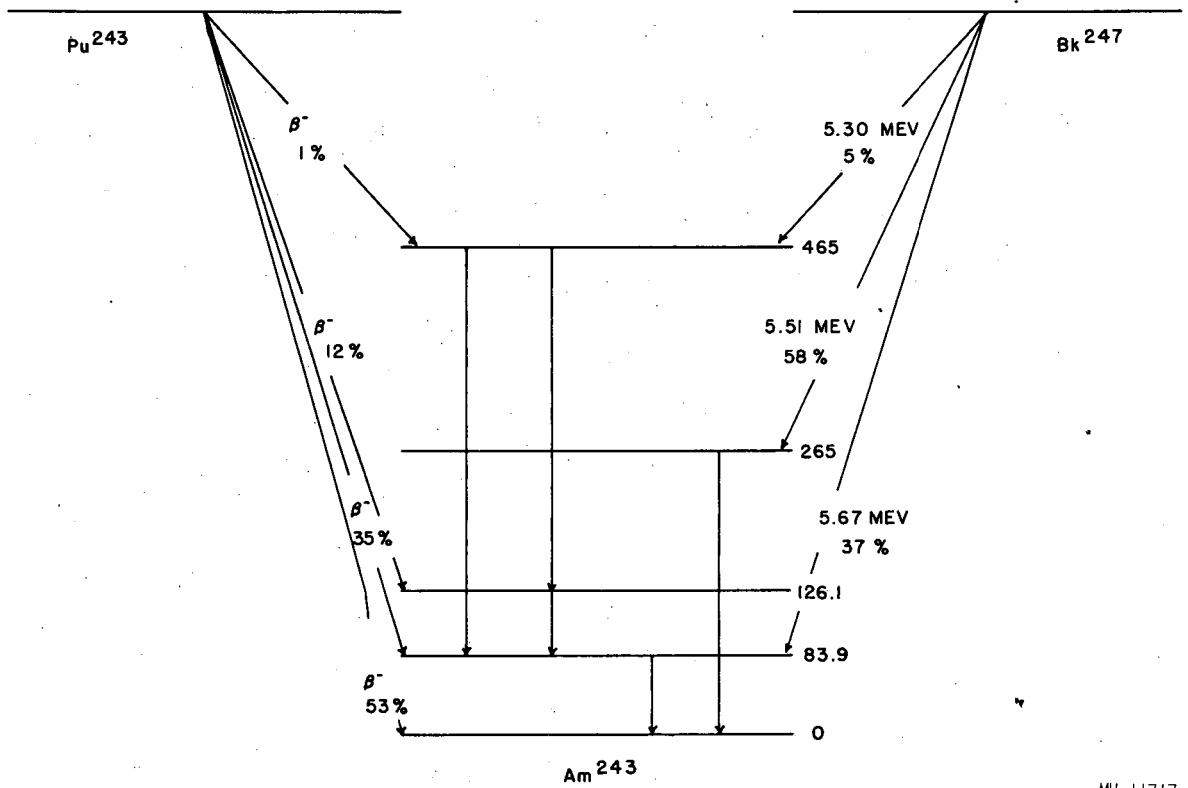

MU-11717

Fig. 27. Alpha-decay scheme of Bk²⁴⁷.

energies shown were derived from the conversion electron data of Stephens and Asaro.

Since little possibility exists of detecting the 7600-year Am^{243} daughter of Bk^{247} , the half life of the berkelium isotope was estimated from its yield in the original bombardment. This estimate is made difficult by the fact that Bk^{247} can be made in several ways. When reasonable assumptions for the cross sections involved are made, however, the half life for alpha decay is estimated at 10^4 years. This estimate is felt to be within a factor of two of the true value. Since no evidence was obtained for electron capture, a branching ratio cannot be determined. Even if all the observed proportional-counter activity is attributed to Bk^{247} rather than to Bk^{249} ; however, the half life for Bk^{247} is in excess of 250 years.

The assignment of the new isotope to mass number 247 was based on the known properties of all other berkelium isotopes that could have been made in the bombardment, the similarity in alpha decay pattern to the isotopes Bk^{243} and Bk^{245} , and the production of Bk^{248} by thermal neutron capture as described later.

The alpha-decay energy calculated from the alpha spectrum and decay scheme is 5.87 Mev. This is somewhat lower than the previous estimate of 5.94 used by Glass et al.³⁰ in closed-cycle calculations, and the revised estimate of the decay energy available to the Cm^{247} - Bk^{247} isobaric pair becomes ~40 kev in favor of the beta stability of Cm^{247} . Since the uncertainty in this value is considerably greater than the decay energy, the beta stability of Cm^{247} must be again considered an open question.

6. Berkelium-248

Almost immediately after the identification of Bk^{247} , a small fraction of this activity was subjected to neutron irradiation in the attempt to prepare the previously unknown isotope Bk^{248} . About 10^7 atoms of the separated Bk^{247} were irradiated for five days in the Materials Testing Reactor at an average flux of 2×10^{14} neutrons per square centimeter per second. The sample was received about 24 hours after the end of bombardment and separated from fission products and miscellaneous induced activities. The separated berkelium fraction was

found to contain about 800 disintegrations per minute of a new berkelium isotope decaying by both electron capture and beta emission with a half life of 16 ± 3 hours, in reasonable agreement with the half-life deduced by Hulet⁵⁰ several days earlier from the growth of Cf^{248} into a mixture of cyclotron-produced berkelium isotopes from the helium-ion bombardment of Cm^{244} .

Careful measurements of the growth of Cf^{248} into the berkelium sample served to establish the mass number of the new activity as 248. The amount of Cf^{248} actually found was in excellent agreement with the amount calculated from the observed berkelium activity and beta-to-electron-capture branching ratio determined later.

The beta-particle spectrum of Bk^{248} was observed with an anthracene crystal scintillation spectrometer in connection with a fifty-channel pulse-height analyzer. The low counting rates and limited time available for measurement prevented an accurate determination of the beta end point; however, extrapolation of the spectrum shown in Fig. 28 gave a maximum beta energy of 650 ± 50 kev. Examination of the electromagnetic spectrum in coincidence with beta particles revealed no gamma radiation ($\leq 10\%$) which finding, together with the beta energy, implies that the decay is predominantly to the ground state of the daughter. It is interesting to note that no L x-rays from the de-excitation of the 2+ level of Cf^{248} were observed ($< 3\%$), and hence only the first member of the rotational band is populated by the beta decay.

No photons other than K and L x-rays were seen in the gross gamma spectrum of Bk^{248} , and it was accordingly assumed that the majority of the electron-capture decays are to the ground state of Cm^{248} . From the observed x-ray intensities, a K to L+M+... capture ratio of ~ 1 was calculated. The uncertainties in this value are large, and perhaps sufficient to account for the discrepancy between this number and the theoretical values of Hoff⁵¹ (2 to 5) based on the estimated 0.68-Mev decay energy.

A beta-to-electron-capture ratio of 2.4 was determined from the observed beta disintegration rate and K and L x-ray intensities, corresponding to log ft values of 6.75 and 6.7 for the electron capture and beta decays respectively. The equality of these values is to be expected for ground-state transitions to even-even daughters. This

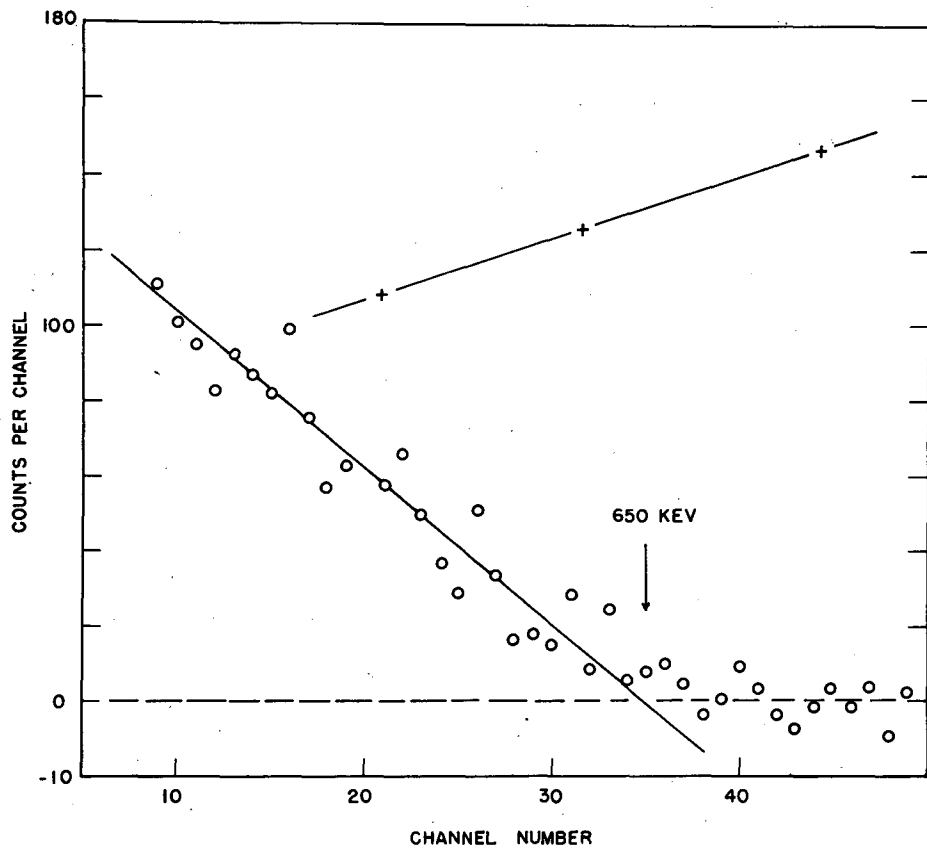

MU-11718

Fig. 28. Beta spectrum of Bk²⁴⁸.

information is summarized in the decay scheme in Fig. 29.

7. Berkelium-249

Berkelium-249 is the principal isotope of berkelium made in the prolonged irradiation of plutonium with neutrons.⁹ It decays chiefly by the emission of 90-keV beta particles with a half life of ~280 days, and also by emission of 5.40-MeV alpha particles (10^{-3} %).¹¹ In view of the previous measurements on lighter berkelium isotopes, it was of considerable interest to carry out similar studies of Bk^{249} , particularly alpha-gamma coincidence measurements.

Alpha-gamma coincidence studies of Bk^{249} are complicated by the growth of the 470-year Cf^{249} into such samples. The low alpha branching of the berkelium isotope and the complexity of the alpha decay of Cf^{249} combine to limit observations of pure Bk^{249} activity to a few hours following its separation. In the experiments reported here, due allowance for the known radiations of Cf^{249} was always made, while accurate intensity measurements were restricted to times shortly after separation.

In coincidence with the alpha particles from Bk^{249} , a 320 ± 10 -keV gamma ray was observed in addition to K x-rays and copious L x-rays. The corrected intensities are given in Table X. Taking first the 320-keV photon, if it is assumed that all the K x-rays arise from conversion of this gamma ray, we find that the alpha population to the 320-keV level may be estimated as ~6%. No contradiction with earlier work¹¹ is involved here, since a 5.08-MeV alpha group in this abundance would not have been observed in an ion chamber because of experimental difficulties connected with the very high beta-to-alpha ratio of Bk^{249} .

Table X

Electromagnetic radiation in the alpha decay of Bk^{249}	
Photon	Photons per alpha
L x-rays	~20 %
K x-rays	3 %
320 ± 5 keV	4 %

The L x-ray spectrum was observed both with a sodium iodide crystal and a xenon-filled proportional counter. Although the energies of the L_{α} , $L_{\beta 1}$, $L_{\beta 2}$, and L_{γ} photons were in excellent agreement with

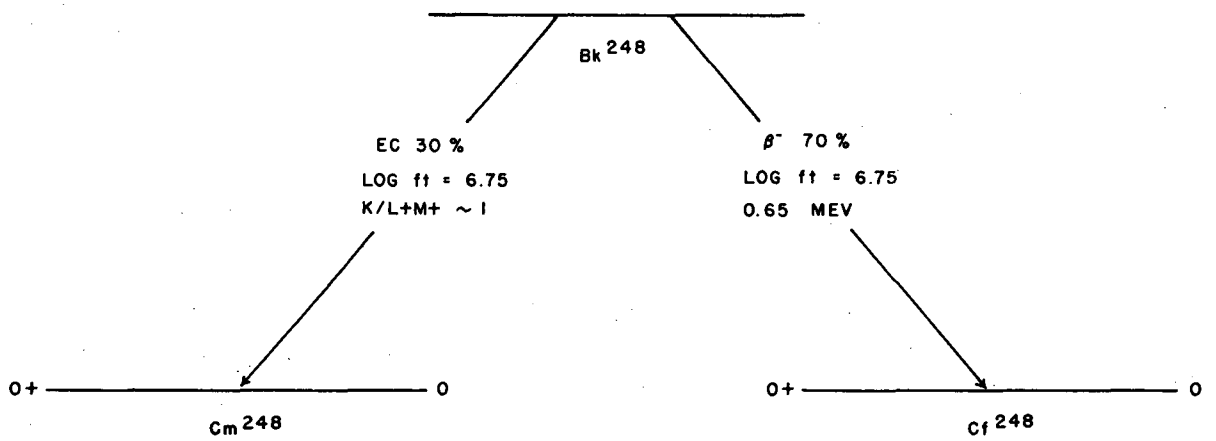

MU-11719

Fig. 29. Beta and electron-capture decay scheme of Bk^{248} .

those expected for americium, their relative intensities were unusual in comparison with the L x-ray spectra of lower-mass odd-proton alpha emitters. The observed L x-ray distribution was quite similar, however, to that found in E^{253} decay in which rotational levels de-exciting by M1 transitions have been observed, and a similar situation may prevail in the Bk^{249} decay.

The pertinent data on the decay of Bk^{249} are shown in the decay scheme in Fig. 30. As indicated there, no gamma radiation was observed in coincidence with the beta particles from this isotope (< 1%).

B. Californium Isotopes

1. Californium-244

The reassignment of the 44-minute californium alpha emitter to mass number 245, as described later, immediately prompted the search for Cf^{244} . The first evidence for its existence came from helium-ion bombardments of Cm^{244} at energies sufficient to yield the $(\alpha, 4n)$ product. No new alpha groups were observed at first in these bombardments; however, the 27-day alpha-decay daughter of Cf^{244} , namely Cm^{240} , was observed. Although no reasonable reaction path other than $Cm^{244}(\alpha, 4n) Cf^{244}(\alpha) Cm^{240}$ could lead to this isotope, an excitation function (Fig. 13) that confirmed its origin in Cf^{244} alpha decay was obtained.

Further work led to the direct observation of Cf^{244} among the products of the helium-ion bombardment of the lighter curium isotope Cm^{242} . In these experiments, in which the ratio of Cf^{244} to Cf^{245} was more favorable, a new alpha group decaying with a 25 ± 3 -min half life was seen at very slightly higher energy than the 7.11-Mev alphas from Cf^{245} . Milking experiments established the genetic relationship between the new isotope and Cm^{240} , and permitted the unambiguous assignment of the new isotope to mass number 244. This conclusion could also have been reached from the shape and threshold of the excitation function.

Careful measurements of the alpha-particle energy of Cf^{244} were made by alpha pulse-height analysis and comparison with E^{253} , Cm^{242} , Cf^{249} , and Fm^{254} . The energy obtained was $7.17 \pm .01$ Mev. A somewhat more precise value of 55 ± 5 kev was found for the $Cf^{244} - Cf^{245}$ energy difference by direct comparison.

In view of the small amounts of activity that were produced in

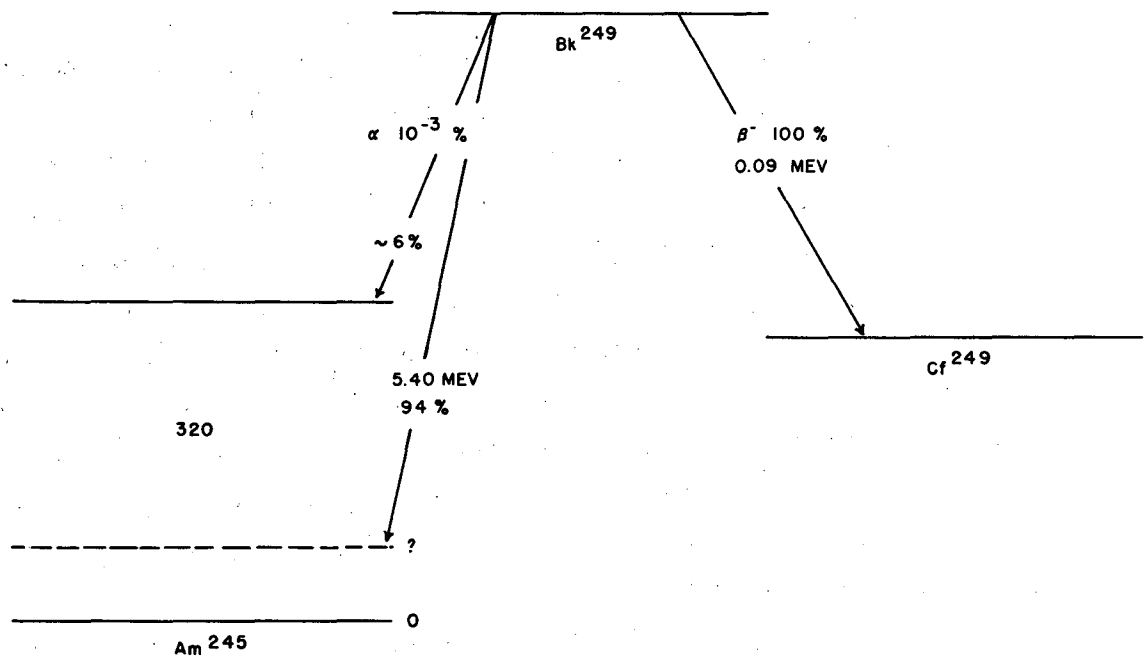

MJ-11720

Fig. 30. Alpha and beta decay scheme of Bk^{249} .

these experiments, no studies of the electron-capture decay of the new isotope were attempted. Closed-cycle calculations³⁰ indicated an electron-capture decay energy of ~ 0.6 Mev for Cf^{244} , corresponding to a partial half life of from several hours to several days. Electron-capture branching, accordingly, is expected to be small.

2. Californium-245

Californium-245 was first produced in 1950 by Thompson et al.,⁴ who identified the new isotope chemically and showed it to decay with a 44-minute half life, principally by the emission of 7.1-Mev alpha particles. The original tentative mass assignment was to 244, a choice based on alpha-decay systematics and the short half lives for electron capture that were predicted for Cf^{243} and Cf^{245} at that time. Because of the limited target materials available in 1950, attempts to establish a genetic relationship to Cm^{240} were inconclusive.

In an extended series of bombardments of curium isotopes with helium ions of various energies, several types of evidence for the assignment of this isotope to mass number 245 rather than 244 were obtained. This evidence may be summarized as follows.

(a) In four separate experiments the californium fraction from the bombardment of Cm^{244} with helium ions below the $(\alpha, 4n)$ threshold was separated chemically, and the decay of the 7.1-Mev alpha emitter was followed by counting in a grid ionization chamber connected to a 48-channel pulse-height analyzer. After the 44-minute activity had decayed for several half lives, a careful search was made for the 6.26-Mev alpha particles of the 27-day Cm^{240} . In every case less than 5% of the amount of Cm^{240} that would result from the decay of the 44-minute activity was found.

(b) An excitation function for the production of the 44-minute activity by the (α, xn) reaction on Cm^{244} was determined by alpha-pulse analysis of the californium fractions from a number of such bombardments. The excitation function so obtained is shown in Fig. 13, in which the cross sections reported were calculated from the observed alpha activity and the branching ratio determined in a separate experiment. The magnitude of the cross sections is such that any contribution of Cf^{244} to the alpha activity ascribed to Cf^{245} was negligible under the conditions

of the experiments. The excitation function for the formation of the 44-minute activity exhibits quantitatively and qualitatively the behavior of an $(\alpha, 3n)$ reaction.

(c) Cross bombardments of Cm^{244} at energies well below the $(\alpha, 4n)$ threshold and of Cm^{242} were shown to produce the 44-minute californium in high yield. Only Cf^{245} could have been produced in both types of experiments.

In order to examine some features of the alpha decay of this isotope, a sample of californium containing approximately 1200 disintegrations per minute of Cf^{245} and approximately 750 disintegrations per minute of Cf^{246} (6.76 Mev, 35.7 hours) was investigated by alpha-gamma coincidence techniques for the presence of L x-rays in coincidence with alpha particles. No such L x-rays were found that could be attributed to Cf^{245} and, by direct comparison with the Cf^{246} present in the sample, an upper limit to their abundance was set at 2% of the alpha decays. Since every even-even alpha emitter that has been studied in the region above uranium decays about 20% to an excited state with attendant L x-rays in 10% to 15% abundance, this is additional strong evidence that the 44-minute activity is not an even-mass californium isotope. No other photons of appreciable intensity were seen in this experiment, and the Cf^{245} was assumed to decay almost exclusively to the ground state of Cm^{241} .

Since Cf^{245} was expected to exhibit appreciable decay by electron capture, an experiment to measure the alpha-to-electron-capture ratio was carried out. The californium fraction resulting from the bombardment of Cm^{244} below the $(\alpha, 4n)$ threshold was isolated soon after the end of bombardment, and the amount of Bk^{245} that grew from the electron-capture decay of Cf^{245} was determined. From the results of this experiment, Cf^{245} was found to decay about 70% by electron capture. The partial half lives for alpha decay and electron capture are, then, about 100 minutes and 60 minutes respectively, in excellent agreement with the half lives predicted by alpha-decay systematics³⁹ and the recent electron-capture systematics by Hoff and Thompson.³²

An accurate determination of the alpha-particle energy of Cf^{245} was made by comparison with several other alpha emitters by alpha-pulse

analysis, yielding the value $7.11 \pm .01$ Mev. As mentioned previously, this energy differs from that of Cf^{244} by only 55 kev.

3. Californium-246

Californium-246 was first produced by Ghiorso and co-workers⁵² by the bombardment of natural uranium with carbon ions accelerated in the 60-inch cyclotron of the Crocker Laboratory. Further studies carried out by Hulet et al.^{5,6} identified the isotope by chemical separation and subsequent growth of the Cm^{242} daughter. A half life of 35.7 hours was measured by this group, as was the alpha-particle energy of 6.76 Mev. No evidence was obtained for electron-capture decay, although spontaneous fission was observed ($\sim 10^{-4}$ %).

The work reported herein centered about the excitation function for the formation of Cf^{246} by the $(\alpha, 2n)$ reaction on Cm^{244} (reported in an earlier section) and the detailed investigation of the alpha decay of this isotope.

Two bombardments of Cm^{244} were made, which resulted in about 10^6 disintegrations per minute of the californium isotope. In the first of these experiments the alpha spectrum of Cf^{246} was examined by use of the alpha-particle spectrograph described by Reynolds.²⁸ Under the extremely high resolution available with this instrument, two alpha groups were observed, at 6.753 and 6.711 Mev with intensities of 78% and 22% respectively. Alpha-gamma coincidence experiments revealed gamma rays of 42, 96, and 146 kev in addition to L x-rays. In the second experiment the coincidence measurements were repeated with much larger samples of Cf^{246} in greater isotopic purity. The results of these measurements are shown in Table XI and in the spectrum in Fig. 31.

Table XI

Electromagnetic radiation in the alpha decay of Cf^{246}	
Photon	Intensity per alpha
42 ± 3 kev	1.4×10^{-2} %
96 ± 3 kev	1.2×10^{-2} %
146 ± 5 kev	3.5×10^{-3} %

The interpretation of these data⁵³ followed the pattern established for rotational bands based on the ground state of even-even nuclei found uniformly throughout the heavy-element region. The various gamma rays

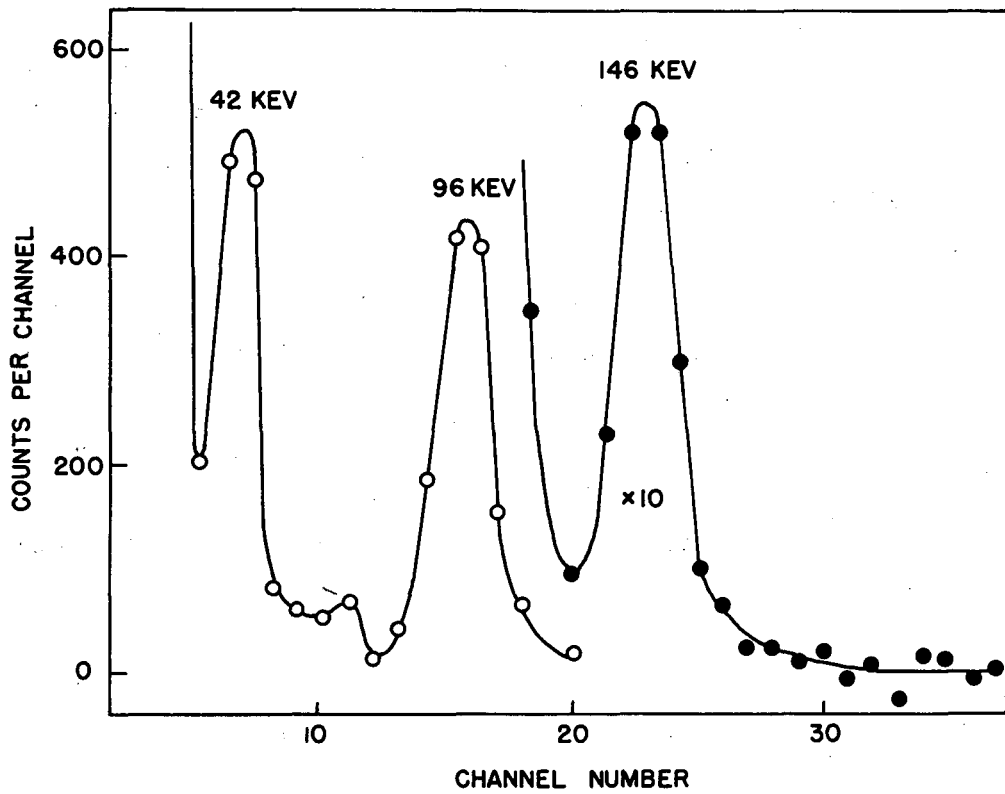

MU-11721

Fig. 31. Gamma spectrum in coincidence with alpha particles of Cf^{246} .

were assigned to 2+ to 0+, 4+ to 2+, and 6+ to 4+ transitions, as shown in the decay scheme in Fig. 32. The several alpha populations calculated from the spectrographic results and the coincidence experiments are in excellent agreement with one another and with the predictions of the unified collective and individual-particle model of heavy nuclei.⁵⁴

4. Californium-247

The 2.5-hour Cf^{247} was first found by Hulet et al.,⁷ who prepared the isotope by the (α, n) reaction on Cm^{244} . It was reported to decay exclusively by electron capture, and a 295-keV gamma ray was observed in its spectrum.⁶ Earlier indication of a californium isotope with these properties⁸ had been obtained in the bombardment of uranium with carbon ions accelerated in the 60-inch cyclotron of the Crocker Laboratory. In the series of studies here reported, these results were confirmed and extended by the production of larger amounts of the isotope and the application of coincidence techniques to the study of its decay. In every case, the method of production was the helium-ion bombardment of heavy curium isotopes, principally Cm^{244} . The yield of Cf^{247} in these bombardments has been indicated in Fig. 14.

Several measurements of the rate of decay of Cf^{247} were made on a number of samples prepared as above. The resultant best value for the half life of this isotope, $2.45 \pm .15$ hours, agrees closely with that given by Hulet.⁷

No direct mass assignment of this activity has been carried out; however, several lines of evidence support the assignment to mass 247. In the milking experiment, mentioned in connection with the search for Bk^{247} , no activity was observed in the separated berkelium fraction resulting from the decay of Cf^{247} . Since Bk^{245} , Bk^{246} , and Bk^{248} (but not Bk^{247}) could have been detected easily under the condition of the experiment, the failure to observe activity argues strongly for the usual assignment. Further evidence consistent with the mass-247 assignment derives from the known properties and mass assignments of the other californium isotopes from Cf^{244} to Cf^{253} , and the rough excitation function obtained for Cf^{247} production.

The gamma spectrum of Cf^{247} was found to consist of peaks at 295 and 417 keV in addition to K and L x-rays with the relative corrected

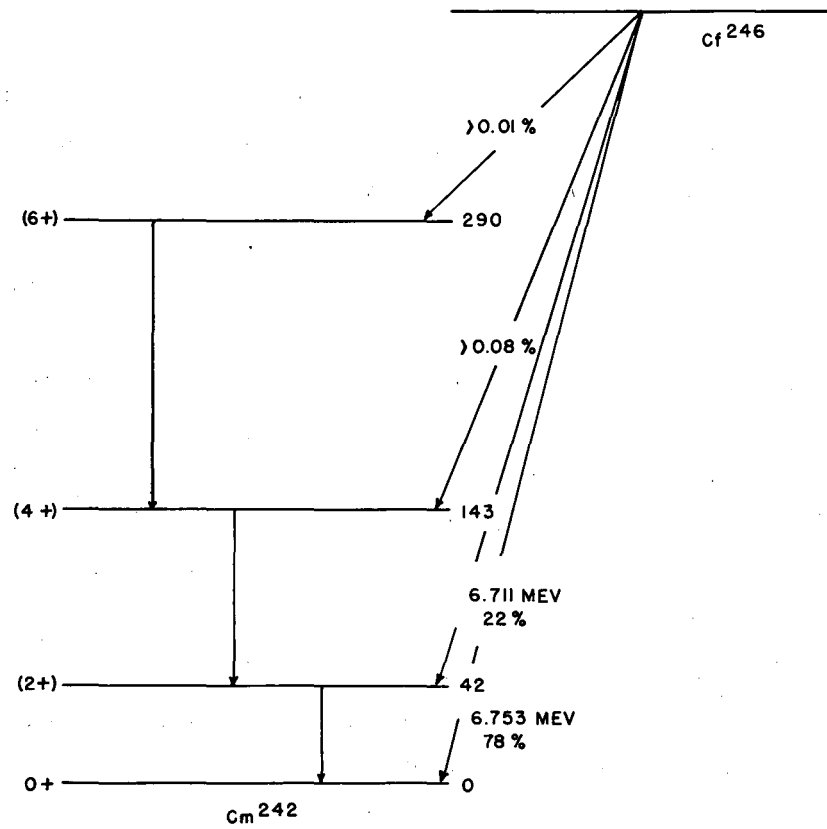

MU-11722

Fig. 32. Alpha-decay scheme of Cf^{246} .

intensities of Table XII. Since the spectrum of Cf^{247} was always observed in the presence of much larger amounts of Cf^{246} , L x-ray intensities were obtained by resolution of the L x-ray decay curve and are accordingly somewhat uncertain. As indicated in the spectrum of Fig. 33, the high-energy gamma peak was clearly complex and could be resolved into two gamma rays of 417 and 460 kev. This resolution was further supported by the spectrum observed in coincidence with L x-rays, in which the 417-kev peak was greatly enhanced relative to the 460-kev component.

Following examination of the gamma spectrum, an extended series of coincidence measurements were made in which the radiations in coincidence with L x-rays, K x-rays, the 295-kev gamma, and the 417-kev gamma were observed. The results of these experiments are summarized in Table XIII, in which the intensities have been corrected for geometry, absorbers, and counting efficiencies as required. The intensities found in the L x-ray coincidence experiments are subject to error as mentioned above. It should also be noted that the K x-ray - K x-ray abundance shown must be divided by about 2 in order to get the true

Table XII

Electromagnetic radiation in the electron-capture decay of Cf^{247}	
Photon energy	Relative intensity
L x-rays	1
K x-rays	1.00
295 ± 5 kev	0.020
417 ± 8 kev	0.013
460 ± 10 kev	0.009

Table XIII

Coincidence measurements of Cf^{247} electron-capture decay				
Gate	L x-rays	K x-rays	295	417
L x rays	---	.46	.0031	.01
K x-rays	---	.025	.0076	.0021
295 kev		.42		
400-480 kev		.10		

coincidence rate, since either coincident photon may appear in the gate detector.

The reasonable assumption was made that all the K x-ray - K x-ray

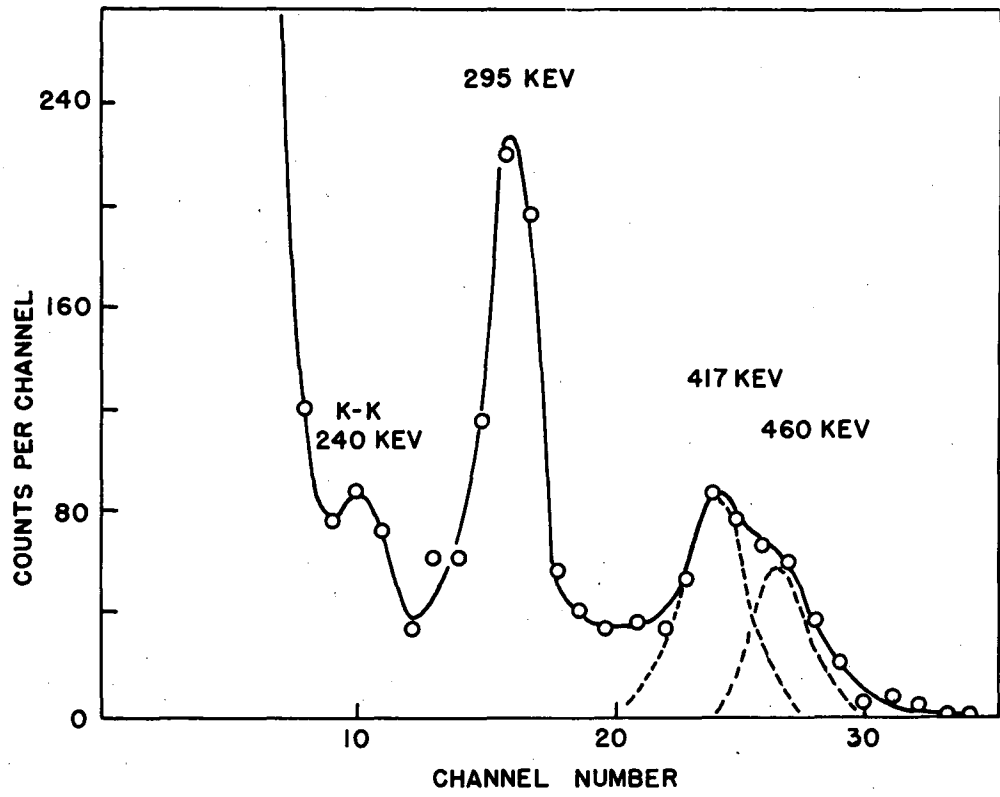

MU-11723

Fig. 33. Gamma spectrum of Cf^{247} .

coincidences arise from conversion of the 295-keV gamma ray, and the K conversion coefficient was calculated from the K x-ray and 295-keV gamma abundances in coincidence with K x-rays. The experimental value, ~1.3, agrees closely with that expected for an M1 transition of this energy.⁴⁰

A decay scheme consistent with the data obtained is shown in Fig. 34, together with populations and K-to-L ratios calculated from the appropriate measurements. The K-to-L capture ratio to the ground state should be regarded as a rough estimate only, because of the uncertainty in the L x-ray intensities. The value obtained, however, is not unreasonable for an allowed or first-forbidden transition, as indicated in the comparison of Table XIV with the theoretical predictions by Hoff.⁵¹

Table XIV

K/L capture ratios and log ft values for the decay of Cf ²⁴⁷					
Transition	Allowed	1st forbidden	2nd forbidden	Experimental	Log ft
K/L to 0 keV	4.3	2.5	1.1	~2-5	5.6
K/L to 295 keV	3.5	1.4	.5	0.75	6.6
K/L to 460 keV	3.0	.95	.24	0.1	6.8

VI. DISCUSSION OF RESULTS

A detailed interpretation of the decay data presented here lies considerably outside the limits imposed either by the experimental results or the present state of theoretical development. Nevertheless, it seems worth while to attempt a brief discussion of some of these results in terms of their empirical correlations, both within the series studied and with other data in the heavy-element region. It is to be hoped that such correlations may provide the basis for continued interest in and further investigations of these nuclides.

A. Orbital Electron Capture in the Berkelium Isotopes

Since Bk²⁴⁹ is stable with respect to electron capture and Bk²⁴⁷ has yielded no information on this mode of decay, the odd-mass berkelium isotopes are represented only by Bk²⁴³ and Bk²⁴⁵. In gross features, these two decay schemes appear to be quite unrelated; however, this may be due in large part to the large differences in the decay energies available. Levels analogous to those responsible for the intense 740-

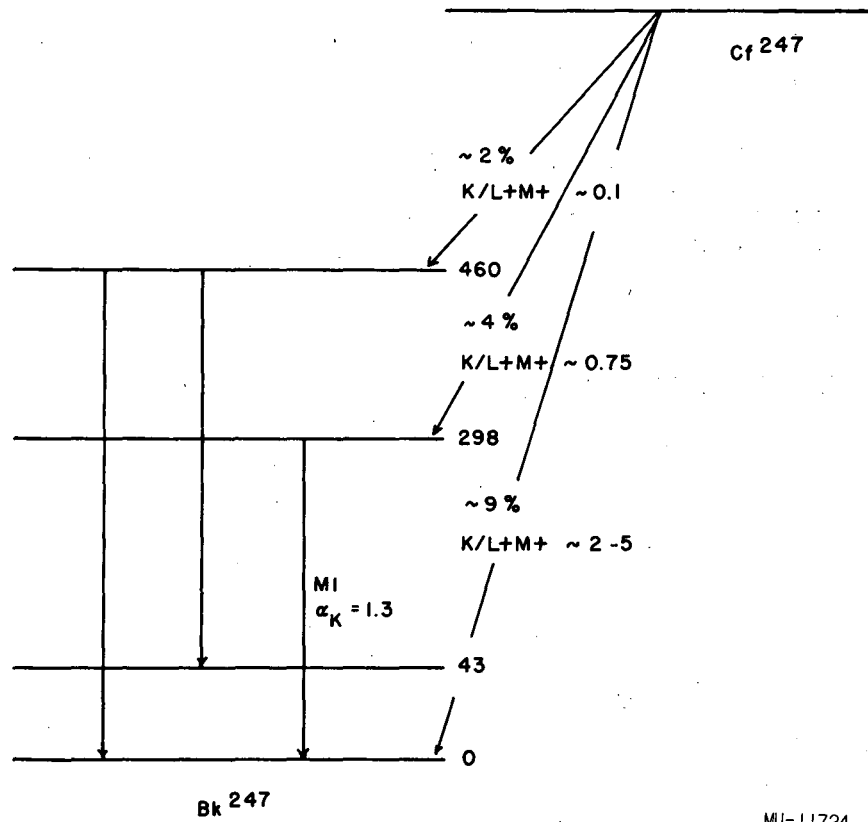

MU-11724

Fig. 34. Electron-capture decay scheme of Cf^{247} .

840-, and 960-keV gamma rays of Bk^{243} , for example, could not be populated by K capture in Bk^{245} with only 0.80 MeV of decay energy.³⁰ Similarities, if any, between the decay schemes of these isotopes must be sought in low-energy low-intensity transitions in the Bk^{243} spectrum, about which there is no information at present.

The absence of the ground-state transition in the electron-capture decay of Bk^{245} requires some mention. Log ft values for decay to the 252- and 632-keV levels are both about 7, corresponding to the first-forbidden [$\Delta I = 0, 1$ yes] classification of Hoff and Rasmussen.⁵⁵ Failure to observe the ground-state transition in these experiments requires a log ft for this decay of ~ 8.6 . While this value does not permit the assignment of higher-order forbiddenness, it would be desirable to obtain further data on this point.

In contrast to the odd-mass case, the decay patterns observed for Bk^{244} and Bk^{246} are quite similar to each other and to other decay schemes to even-even nuclei. Several level diagrams of even-even nuclei are shown in Fig. 35 for comparative purposes. The data for the Pu^{238} nucleus are from the work of Rasmussen et al.^{56,57} on the decay of Np^{238} and from Asaro's studies of Cm^{242} alpha decay,⁵⁸ while the data on the Cf^{250} nucleus is from work by Asaro and others⁴⁷ on the electron capture of E^{250} and the beta decay of Bk^{250} .⁵⁹

The various features of the Pu^{238} nucleus, as a representative example of this type, have been discussed by Rasmussen in connection with the Np^{238} decay.⁵⁷ Of particular interest here are the well-established series of 0+, 2+, and 4+ rotational levels based on the ground state and the levels at 1029 and 1073 keV, which have been assigned spins and parities of 2+ and 3+ respectively. There is some evidence that these latter levels may be members of another rotational band based on a vibrational excited collective state which has been predicted in heavy even-even nuclei at about 1 MeV.⁶⁰ The ground-state rotational band is clearly implied in all four of the illustrated decays, and it is tempting to assume that some of the levels that decay characteristically to this band in Cm^{246} and Cf^{250} nuclei are members of a 2+, 3+, ... series analogous to that in Pu^{238} . Some of the high-energy transitions observed in Bk^{244} decay may also originate in such levels.

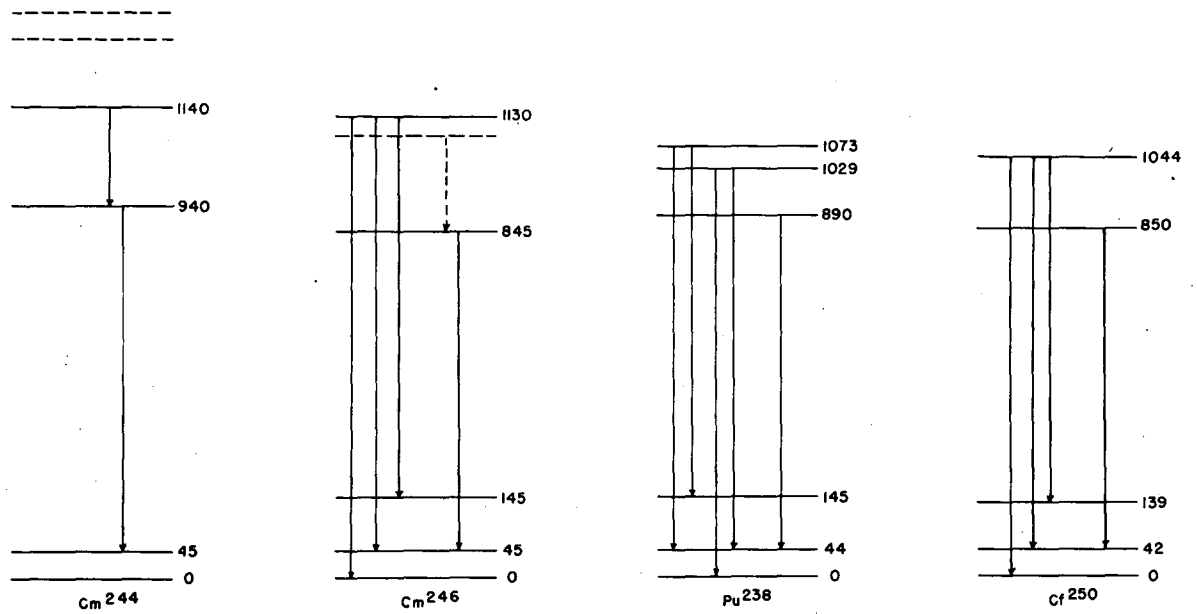

MU-11725

Fig. 35. Level diagrams of some even-even nuclei.

The gamma transitions of 700 to 900 keV shown in Fig. 35 seem to be populated erratically in beta decay. No evidence for the 890-keV state was obtained from the beta decay^{56,57} of Np^{238} , although Asaro⁵⁸ has observed population of this level in Cm^{242} alpha decay to the same nucleus, Pu^{238} . Similarly, beta decay⁵⁹ of Bk^{250} does not go to the 850-keV state of Cf^{250} , although this level is heavily populated in the electron-capture decay⁴⁷ of E^{250} , though perhaps not directly. On the other hand, the 800- and 900-keV gamma in Bk^{244} and Bk^{246} decay are among the most intense in the spectrum, and the 800-keV gamma has also been observed⁶¹ in high abundance in the decay of Am^{246} . While no explanation for this apparently typical state or its erratic population is readily available, some of its characteristics seem well established. The decay of this level seems to be principally to the $2+$ level, with very little branching to the ground state. The observable consequences of this type of decay are the lack of complexity in the gamma peak and the presence of L x-rays in coincidence with the gamma ray. Further identification of this type of transition in other even-even nuclei would be desirable.

B. Alpha Decay in the Odd-Mass Berkelium Isotopes

The series of odd-mass berkelium isotopes provides an almost unique opportunity for the study of alpha decay by closely related nuclei in the heavy-element region. The various data recorded for these isotopes have been reported earlier without, however, emphasizing the similarity that exists between their decay patterns. The alpha-decay schemes for Bk^{243} , Bk^{245} , Bk^{247} , and Bk^{249} have been collected in Fig. 36, together with additional information derived from the previous data. Conversion coefficients for the highest-energy gamma rays were calculated from the experimental alpha populations to the levels and the gamma ray abundances in Bk^{243} and Bk^{245} . The conversion coefficient for the 320-keV gamma of Bk^{249} decay was obtained directly from the gamma and K x-ray intensities, assuming no other source of K x-rays. All these coefficients are consistent with an M1 assignment⁴⁰ for the transitions. Hindrance factors for the alpha decay to the various levels are indicated as underlined values above the daughter levels. "Hindrance factor" as used here is the ratio of

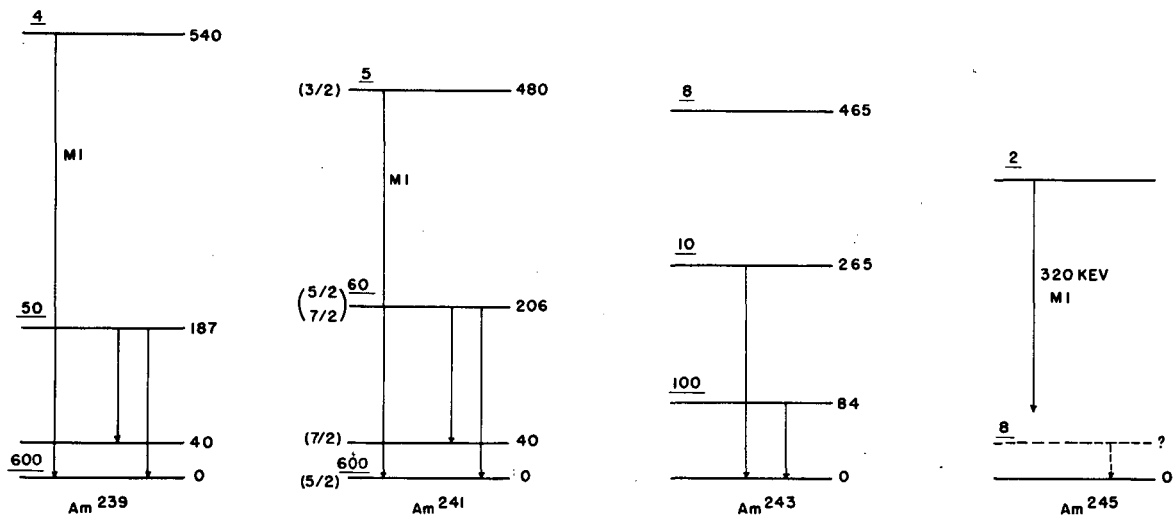

MU-11726

Fig. 36. Alpha-decay schemes of the odd-mass berkelium isotopes.

the experimental half life for a particular alpha group to the theoretical half life expected from spin-independent alpha-decay theory.⁶²

The choice of nuclear radius was determined by extrapolation from the nearest even-even alpha emitters.

Although considerable continuity of energy levels is indicated by the comparison of the figure, the quantitative demonstration of the similarities is difficult, as uncertainties exist in both alpha and gamma abundances from the experimental data. The highest states in these isotopes share several common features, such as comparatively low hindrance factors, a fairly smooth dependence of energy on mass number, and decay by M1 transitions to the ground state. None of these points provides certain identification of the levels involved; however, their sum is strongly suggestive of a common classification. It should be noted that the absence of a level in Bk²⁴⁹ decay analogous to the 187-, 206-, and 265-keV levels of the lighter isotopes is not necessarily anomalous. Extrapolation of the energy trend in Bk²⁴³, Bk²⁴⁵, and Bk²⁴⁷ places this unobserved level very close to the 320-keV state. In view of the relative hindrance factors involved, population by alpha decay would be almost entirely in favor of the 320-keV level.

The states observed at 84 keV in Bk²⁴⁷ decay and at an undetermined energy in Bk²⁴⁹ decay have no obvious counterpart in the schemes of Bk²⁴³. It is possible that these levels may be similar to those giving rise to low-energy E1 transitions in the odd-mass neptunium isotopes, as discussed by Stephens.

As a first rough indication of the level sequence that may obtain in some of these nuclei, reasonable spins have been assigned to the Am²⁴¹ levels observed in the alpha decay of Bk²⁴⁵. The argument that leads to this assignment assumes a rotational band based on the ground state (known to have spin 5/2),⁶³ and the applicability of the gamma-intensity formulae of Alaga et al.⁶⁴ to M1 transitions. Combination of this treatment with conversion coefficients estimated from intensity measurement results in the spins shown in Fig. 36. The parity of the 206-keV level probably differs from that of the ground state.

C. Decay Energies

Alpha-decay energies of the berkelium and californium isotopes show two special features of interest. The first of these is the extra stability of the 152-neutron configuration, as pointed out by Ghiorso et al.⁶⁵ Of the isotopes studied in this work, only Bk²⁴⁹ and perhaps Bk²⁴⁷ partake strongly of this extra stability, as reflected in their alpha-decay energies. The second point of interest is the much smaller departure from a smooth trend of alpha-decay energy with mass number, indicated by the very slight energy differences between the alpha-decay energies of the Bk²⁴³-Bk²⁴⁴ and Cf²⁴⁴-Cf²⁴⁵ pairs. Both of these effects are illustrated in Fig. 37.

As indicated in the figure, the decay energies of the Cm²⁴²-Cm²⁴³ pair are also unusually close,³⁰ and the difference between the two, 60 kev, is almost identical with the corresponding 55-kev difference in berkelium and californium. Since neither the Cm²⁴⁰ or Pu²³⁸ alpha-decay energies seems unusually large, the above observations probably imply an extra stability of 100 to 150 kev associated with the 146-neutron configuration. Energy differences of this magnitude are on the order of those expected from pairing energies in this region; however, other explanations are by no means precluded.

The electron-capture and beta-decay energies found in this study are all in reasonable agreement with the estimates and closed-cycle calculations of Glass et al.³⁰ The few modifications required by the experimental values have been incorporated in the revised tables of Foreman, from which the data of Table XV were compiled. The source of the values (calculated, estimated, etc.) is indicated by the conventions of Glass.³⁰

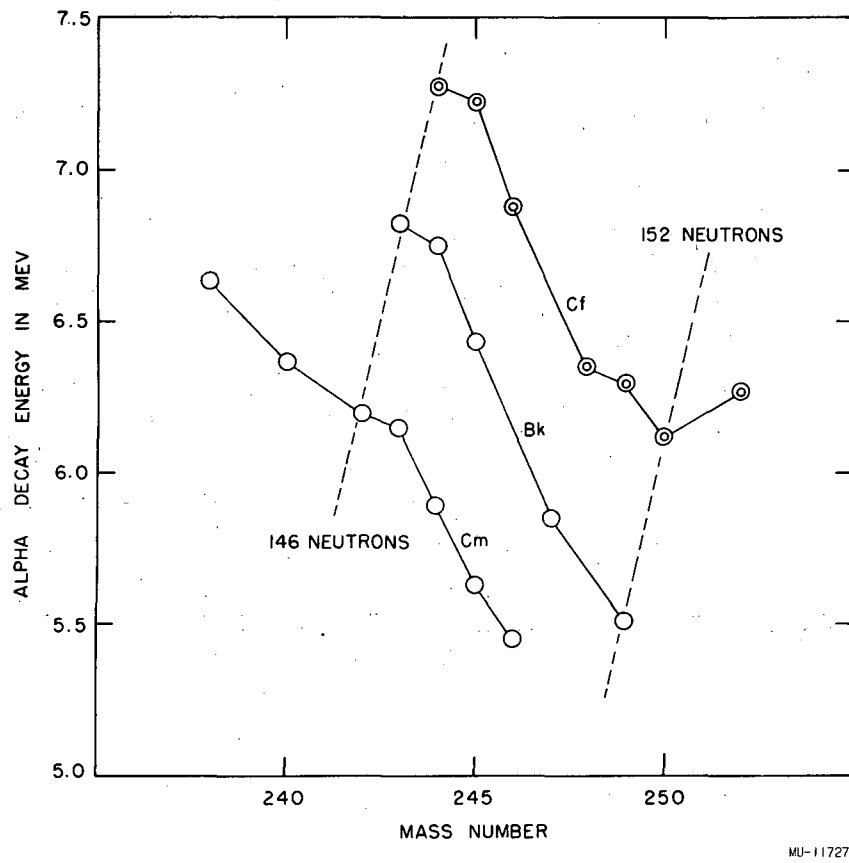

Fig. 37. Alpha-decay energies of the curium, berkelium, and californium isotopes.

Table XV

Decay energies of the berkelium and californium isotopes			
Isotope	Q_{α}	Q_{β}	Q_{ec}
Bk ²⁴³	6.83	stable	1.54 c
Bk ²⁴⁴	6.77	stable	2.32 ce
Bk ²⁴⁵	6.44	stable	0.80 c
Bk ²⁴⁶	6.15 e	stable	1.34 ce
Bk ²⁴⁷	5.85	stable	0.04 ce
Bk ²⁴⁸	5.52 c	0.66	0.65 ce
Bk ²⁴⁹	5.51	0.10	stable
Bk ²⁵⁰	5.73 c	1.90	0.00 e
Cf ²⁴⁴	7.29	stable	0.60 ce
Cf ²⁴⁵	7.23	stable	1.64 ce
Cf ²⁴⁶	6.86	stable	0.12 ce
Cf ²⁴⁷	6.62 e	stable	0.77 ce
Cf ²⁴⁸	6.36	stable	stable
Cf ²⁴⁹	6.31	stable	stable
Cf ²⁵⁰	6.12	stable	stable
Cf ²⁵¹	6.32 e	stable	stable
Cf ²⁵²	6.28	stable	stable
Cf ²⁵³	6.20 e	0.54 ce	stable

ACKNOWLEDGMENTS

It is a pleasure to acknowledge the extensive interest, guidance, and direct assistance of the personnel of the Chemistry Division. Thanks are due, in particular, to Stanley G. Thompson, Bernard G. Harvey, Albert Ghiorso, Robert G. Silva, Frank Asaro, Frank S. Stephens, Gregory R. Choppin, and Thomas C. Parsons, who participated directly in much of the experimental work and subsequent interpretation.

The author is greatly indebted to Joseph G. Hamilton, the late G. Bernard Rossi, William B. Jones, and the entire staff and crew of the Crocker Laboratory 60-inch cyclotron for their cooperation and help with the many bombardments.

Finally, the encouragement and direction of Professor Glenn T. Seaborg, under whose supervision this work was done, is gratefully acknowledged.

This work was done under the auspices of the U. S. Atomic Energy Commission.

LIST OF ILLUSTRATIONS

	Page
Fig. 1. Reaction paths in the thermal-neutron irradiation of Am ²⁴¹	8
Fig. 2. Yields in the thermal-neutron irradiation of Am ²⁴¹ ...	9
Fig. 3. Reaction paths in the thermal-neutron irradiation of Pu ²³⁹	11
Fig. 4. Yields in the thermal-neutron irradiation of Pu ²³⁹ ...	12
Fig. 5. Separation of americium from some common impurities..	15
Fig. 6. Elution positions of the rare earths, americium and curium.....	16
Fig. 7. Electrodeposition cell.....	19
Fig. 8. Schematic diagram of the deflector-channel probe.....	22
Fig. 9. Range-energy curves for astatine recoils in bismuth metal.....	24
Fig. 10. Electrodeposition yield as a function of current density.....	27
Fig. 11. Electrodeposition yield as a function of electrolysis time.....	28
Fig. 12. Excitation function for the Cm ²⁴⁴ (α ,2n) Cf ²⁴⁶ reaction.....	32
Fig. 13. Excitation functions for some (α ,xn) reactions on Cm ²⁴⁴	33
Fig. 14. Excitation functions for some (α ,xn) and (α ,pxn) reactions on Cm ²⁴⁴	35
Fig. 15. Excitation functions for some (α ,xn) reactions on Am ²⁴³	36
Fig. 16. Gamma spectrum of Bk ²⁴³ in the 500-1000-kev region...	39
Fig. 17. Gamma spectrum in coincidence with alpha particles of Bk ²⁴³	41
Fig. 18. Alpha-decay scheme of Bk ²⁴³	42
Fig. 19. Tentative and partial electron-capture decay scheme of Bk ²⁴⁴	45
Fig. 20. Electron-capture decay scheme of Bk ²⁴⁵	50
Fig. 21. Alpha decay scheme of Bk ²⁴⁵	51
Fig. 22. Gamma spectrum of Bk ²⁴⁵ and Bk ²⁴⁶	53

	Page
Fig. 23. Resolution of 1.09-Mev peak of Bk ²⁴⁶	54
Fig. 24. Tentative and partial electron-capture decay scheme of Bk ²⁴⁶	55
Fig. 25. Elution curve of final separation of Bk ²⁴⁷	58
Fig. 26. Alpha-particle spectrum of Bk ²⁴⁷	59
Fig. 27. Alpha-decay scheme of Bk ²⁴⁷	61
Fig. 28. Beta spectrum of Bk ²⁴⁸	64
Fig. 29. Beta and electron-capture decay scheme of Bk ²⁴⁸	66
Fig. 30. Alpha and beta decay scheme of Bk ²⁴⁹	68
Fig. 31. Gamma spectrum in coincidence with alpha particles of Cf ²⁴⁶	72
Fig. 32. Alpha-decay scheme of Cf ²⁴⁶	74
Fig. 33. Gamma spectrum of Cf ²⁴⁷	76
Fig. 34. Electron-capture decay scheme of Cf ²⁴⁷	78
Fig. 35. Level diagrams of some even-even nuclei.....	80
Fig. 36. Alpha-decay schemes of the odd-mass berkelium isotopes..	82
Fig. 37. Alpha-decay energies of the curium, berkelium, and californium isotopes.....	85

LIST OF TABLES

		Page
Table I.	Isotopic composition of Am ²⁴³ and Cm ²⁴⁴ target materials.....	13
Table II.	Gamma rays of Bk ²⁴³	40
Table III.	Electromagnetic radiation in the alpha decay of Bk ²⁴³	40
Table IV.	High-energy gamma rays in the electron-capture decay of Bk ²⁴⁴	44
Table V.	Electromagnetic radiation in the electron-capture decay of Bk ²⁴⁵	47
Table VI.	Coincidence measurements of Bk ²⁴⁵ electron-capture decay.....	47
Table VII.	Conversion coefficients of the 295-kev transition in Bk ²⁴⁵	48
Table VIII.	Electromagnetic radiation in the alpha decay of Bk ²⁴⁵	49
Table IX.	Alpha particles of Bk ²⁴⁷	60
Table X.	Electromagnetic radiation in the alpha decay of Bk ²⁴⁹	65
Table XI.	Electromagnetic radiation in the alpha decay of Cf ²⁴⁶	71
Table XII.	Electromagnetic radiation in the electron-capture decay of Cf ²⁴⁷	75
Table XIII.	Coincidence measurements of Cf ²⁴⁷ electron-capture decay.....	75
Table XIV.	K/L capture ratios and log ft values for the decay of Cf ²⁴⁷	77
Table XV.	Decay energies of the berkelium and californium isotopes.....	86

REFERENCES

1. Thompson, Ghiorso, and Seaborg, Phys. Rev. 77, 838 (1950).
2. Thompson, Ghiorso, and Seaborg, Phys. Rev. 80, 781 (1950).
3. Thompson, Street, Ghiorso, and Seaborg, Phys. Rev. 78, 298 (1950).
4. Thompson, Street, Ghiorso, and Seaborg, Phys. Rev. 80, 790 (1950).
5. Hulet, Thompson, Ghiorso, and Street, Phys. Rev. 84, 366 (1951).
6. E. K. Hulet, "An Investigation of the Isotopes of Berkelium and Californium" (Thesis), UCRL-2283, July 1953.
7. Hulet, Thompson, and Ghiorso, Phys. Rev. 95, 1703 (1954).
8. Ghiorso, Rossi, Harvey, and Thompson, Phys. Rev. 93, 257 (1954).
9. Thompson, Ghiorso, Harvey, and Choppin, Phys. Rev. 93, 908 (1954).
10. Ghiorso, Thompson, Choppin, and Harvey, Phys. Rev. 94, 1081 (1954).
11. Diamond, Magnusson, Mech, Stephens, Friedman, Studier, Fields, and Huizenga, Phys. Rev. 94, 1083 (1954).
12. Choppin, Thompson, Ghiorso, and Harvey, Phys. Rev. 94, 1080 (1954).
13. Harvey, Thompson, Choppin, and Ghiorso, Phys. Rev. 99, 337 (1955).
14. Street, Ghiorso and Thompson, Phys. Rev. 85, 1356 (1952).
15. H. P. Robinson, Chemistry Division Quarterly Report, June, July, August 1955, University of California Radiation Laboratory Report UCRL-3157 (1955).
16. H. P. Robinson, unpublished data (1955).
17. Thompson, Harvey, Choppin, and Seaborg, J. Am. Chem. Soc. 76, 6229 (1954).
18. R. J. Silva, H. G. Simens, and T. C. Parsons, unpublished work.
19. Choppin, Harvey, and Thompson, J. Inorg. Nucl. Chem. 2, 66 (1956).
20. G. R. Choppin and R. J. Silva, "Separation of the Lanthanides by Ion Exchange with Alpha-Hydroxy Isobutyric Acid" UCRL-3265, January 1956.

21. A. Ghiorso, unpublished work.
22. A. Ghiorso, and G. B. Rossi, unpublished work.
23. E. K. Hyde, Paper P/728, Vol. VII, Proceedings of the International Conference on the Peaceful Uses of Atomic Energy, United Nations, New York, 1956.
24. D. C. Stewart, Paper P/729, *ibid.*
25. K. A. Kraus and F. Nelson, Paper P/837, *ibid.*
26. A. E. Larsh and A. Ghiorso in UCRL-2647, May 1954.
27. F. S. Stephens, Jr., "Decay Schemes and Nuclear Spectroscopic States in the Heavy-Element Region (Thesis), UCRL-2970, June 1955.
28. F. L. Reynolds, *Rev. Sci. Instr.* 22, 749 (1951).
29. Aron, Hoffman, and Williams, Atomic Energy Commission Unclassified Report AECU-663 (second revision), 1949.
30. Glass, Thompson, and Seaborg, *J. Inorg. Nucl. Chem.* 1, 3 (1955). Revised by B. M. Foreman, Jr., January 1956.
31. Chetham-Strode, Jr., Choppin, and Harvey, *Phys. Rev.*, to be published.
32. R. W. Hoff and S. G. Thompson, *Phys. Rev.* 96, 1350 (1954).
33. E. L. Kelly and E. Segrè, *Phys. Rev.* 75, 999 (1949).
34. Seaborg, Glass, Carr, and Cobble, *Phys. Rev.*, to be published.
35. A. Bohr, "Rotational States of Atomic Nuclei," Ejnar Munksgaard, Copenhagen, 1954.
36. A. Bohr and B. R. Mottelson, Chap. 17 of "Beta and Gamma Ray Spectroscopy," K. Siegbahn, Editor, Interscience Publishers, New York, 1955.
37. J. O. Newton, *Progress in Nuclear Physics* 4, 234 (1955).
38. Hummel, Stephens, and Asaro, unpublished work.
39. I. Perlman and F. Asaro, *Ann. Rev. Nucl. Sci.* 4, 157 (1954).
40. L. A. Sliv, privately circulated data from Russian work.
41. M. E. Rose, Chap. 14 of "Beta and Gamma Ray Spectroscopy," K. Siegbahn, Editor, Interscience Publishers, New York, 1955.
42. A. Ghiorso, unpublished work (1954).
43. Fields, Studier, Friedman, Diamond, Sjoblom, and Sellers, *J. Inorg. Nucl. Chem.* 1, 262 (1955).

44. Brown, Hoffman, Crane, Balagna, Higgins, Barnes, Hoff, Smith, Mize, and Bunker, J. Inorg. Nucl. Chem. 1, 254 (1955).
45. R. A. Glass, "Studies in the Nuclear Chemistry of Plutonium, Americium, and Curium and the Masses of the Heaviest Elements" (Thesis), UCRL-2560, April 1954.
46. Asaro, Stephens, Harvey, and Perlman, Phys. Rev. 100, 137 (1955).
47. Asaro, Stephens, Thompson, Harvey, Ghiorso, Choppin, and Chetham-Strode, unpublished work.
48. F. S. Stephens, Jr., and F. Asaro, unpublished work.
49. Engelkemeir, Fields, and Huizenga, Phys. Rev. 90, 6 (1953).
50. E. K. Hulet, "A New Isotope of Berkelium," UCRL-4581, October 1955.
51. R. W. Hoff, "Orbital Electron Capture in the Heaviest Elements" (Thesis), UCRL-2325, September 1953.
52. Ghiorso, Thompson, Street, and Seaborg, Phys. Rev. 81, 154 (1951).
53. Hummel, Stephens, Asaro, Chetham-Strode, and Perlman, Phys. Rev. 98, 22 (1955).
54. Bohr, Fröman, and Mottelson, Dan. Mat. Fys. Medd. 29, no. 10 (1955).
55. R. W. Hoff and J. O. Rasmussen, Phys. Rev. 101, 280 (1956).
56. Rasmussen, Slätis, and Passell, Phys. Rev. 99, 42 (1955).
57. Rasmussen, Stephens, Strominger, and Aström, Phys. Rev. 99, 47 (1955).
58. Asaro, Harvey, and Perlman, Phys. Rev., to be published.
59. F. Asaro, unpublished work.
60. A. Bohr and B. R. Mottelson, Dan. Mat. Fys. Medd. 27, no. 16 (1953).
61. Engelkemeir, Fields, Fried, Pyle, Stephens, Asprey, Brown, Smith, and Spence, J. Inorg. Nucl. Chem. 1, 345 (1955).
62. Perlman, Ghiorso, and Seaborg, Phys. Rev. 77, 26 (1950).
63. M. S. Fred and F. S. Tomkins, Phys. Rev. 89, 318 (1953).
64. Alaga, Alder, Bohr, and Mottelson, Dan. Mat. Fys. Medd. 29, no. 9 (1955).

65. Ghiorso, Thompson, Higgins, Harvey, and Seaborg, Phys. Rev. 95, 293 (1954).
66. N. Bohr, Dan. Mat. Fys. Medd. 18, 8 (1953).