

UC Riverside

UCR Honors Capstones 2016-2017

Title

Design Analysis of a Novel Wave Energy Converter Device

Permalink

<https://escholarship.org/uc/item/1d0809tr>

Author

Lee, Jonathan Gregory

Publication Date

2017-12-08

DESIGN ANALYSIS OF A NOVEL WAVE ENERGY CONVERTER DEVICE

By

Jonathan Gregory Lee

A capstone project submitted for
Graduation with University Honors

June 15, 2017

University Honors
University of California, Riverside

APPROVED

Dr. Sundararajan Venkatadriagaram
Department of Mechanical Engineering

Dr. Richard Cardullo, Howard H Hays Jr. Chair and Faculty Director, University Honors
Interim Vice Provost, Undergraduate Education

ABSTRACT

The current energy demands are increasing across the globe with imposing technology advancement and population growth. This demand is fueling an even greater need for more renewable energy innovation as the effects of fossil fuels are beginning to be felt more severely. Recent legislation has additionally been accelerating this push for more widespread advancement of renewables. To respond to this need, a project was commenced by the Senior Design team EPA-1 in the Mechanical Engineering department to develop a device to convert the oscillatory motion of ocean waves into usable energy. Through this effort, a complete engineering design process was conducted. The problem statement for the project was to develop a novel device that directly converts the kinetic energy of waves into usable electricity with a power production goal of 500W. A concept was generated and developed into a full scale design. The functionality of this design was verified with a prototype to demonstrate the main operating principles of the device. This prototype was designed as a scaled down version of the full design, and a physical model was constructed. The verification of the design was achieved by testing the prototype in a simulated wave environment. Then an analysis was done to determine the efficiency of the device. An efficiency of 15% was calculated, but further refinement of the testing process is expected to produce better results. Lessons learned from the prototype development and testing are listed in addition to the recommendations of how to improve the design and testing of the full scale design. Overall, the device shows promise as a future option for wave energy harvesting. This device is a product of the work of the entire EPA-1 Senior Design team, but the theory and analysis presented is only the work of the author.

ACKNOWLEDGEMENTS

I would like to first thank Professor Sundararajan, my faculty mentor, for all his patience, advice, and encouragement as my team and I tried to develop this project and struggled through many of the challenges of the process. Sacrificing his time to meet with me whenever I needed guidance, he made himself available and was positive in his approach leaving me more motivated to continue when I would walk away. I would also like to thank Dr. Campbell Dinsmore for his guidance and objectivity during our very early meetings he voluntarily agreed to. The gentlemen in the machine shop, Matt McCormick and Steve Rightnar, are also to be thanked for their mentorship and guidance as they taught so much more than just shop skills. Finally I would like to thank my Senior Design team, Karan Gupta, Jake Eggan, and Jocelyn Esparza, who worked together through thick and thin and made this project the fun and excellent learning experience that it was.

TABLE OF CONTENTS

ABSTRACT.....	ii
ACKNOWLEDGEMENTS.....	iii
TABLE OF CONTENTS.....	iv
1. Introduction.....	1
2. Scope.....	3
3. Wave Energy Converter Design Solution.....	4
3.1 Full Scale Design	6
3.1.1 Design Overview	6
3.1.2 Housing Assembly.....	7
3.1.3 Float Assembly.....	9
3.1.4 Reference Assembly.....	12
3.2 Prototype Design.....	13
3.2.1 Prototype Materials.....	14
3.2.2 Prototype Construction.....	15
4. Wave Theory.....	17
5. Device Power Potential.....	18
6. Device Mechanical Analysis.....	19
7. Experimental Setup.....	22
8. Results and Discussion	24

9. Conclusion and Future Work	25
REFERENCES	28
APPENDIX.....	30

1. Introduction

The global energy demands have rapidly grown over the last century and will continue to grow as technology and industry booms accompany population growth. As increasing demands for energy are met by burning fossil fuels like coal, petroleum, and natural gas, CO₂ emissions and combustion pollutants including soot particulates, nitrogen oxides, sulfur oxides, and carbon monoxide have dramatically increased [1]. In the United States, from 2006 to 2016, this dependence on fossil fuels has slowly decreased from 85% to just above 80% of energy consumed coming from these sources, but this fraction still remains high [2]. Currently, the nation's total energy consumption consists of only around 10.5% renewable energy from sources such as geothermal, solar, hydroelectric, wind, and, most significantly, biomass, but the use of renewable has been growing from 6% during the period of 2000-2007 to where it is today [2].

The growth of renewable energy and technology first gained momentum as a result of the 1973 oil crisis. Since that time, large amounts of government funds for research and development have been invested into several areas of renewable energy including solar, wind, and ocean energy. The push for advancing renewable energy promotes both an environmentally friendly source of energy and a political independence from imported fuels. On May 31, 2017, the California Senate passed Senate Bill 100 (SB 100) which states that by the end of 2045, California's retail energy provided by utilities must be entirely dependent on renewable sources [3,4]. Building up to this ambitious goal, this bill sets milestones of 50% renewable by 2026 and 60% by 2030 [4].

This goal will be challenging to achieve as studies by the National Oceanic and Atmosphere Administration have revealed a steady influx of population growth on the

coast. One study revealed that over 53% of the nation's population lives in coastal areas [5]. Excluding Alaska, these highly populated coastal areas take up only 17% of the nation's land mass, but contain 14 of the nation's 20 largest, most populated cities and 19 of the nation's 20 most densely populated counties [5]. The coastal regions are, thus, far more densely populated than the rest of the United States and will continue to grow at a rate faster than the total population growth of the nation [6]. This large influx of people creates two troubling concerns affecting the environment and available resources in the area. The strain on the coastal ecosystem is the first concern including such factors as increased solid waste, greater amounts of nonpoint runoff, and diminishing animal habitat [5]. The second concern is the greater demand for energy. With such high and rapidly increasing population densities, the inability of local systems to keep up with the growing energy demands of these large cities and communities has driven many coastal communities to open their own natural gas plants and import coal generated electricity from bordering states as is the case with Riverside Public Utilities. To satisfy SB 100, clean energy sources will need to be implemented quickly to account for the loss of these fossil fuel energy sources and keep up with the growing energy demands.

Many sources of renewable energy have already been researched and harnessed to meet some of the current energy demands. Aside from hydroelectricity which is a significant power producer but limited in its application by river location and size, the major alternatives have been solar and wind energy. However, these green energy sources have limitations in their consistency and availability of their power. Wind blows intermittently and the largest daily energy demands spike after the setting of the sun. Furthermore, the industry fields surrounding these two sources are mature and beyond

their prime causing a lower likelihood of further substantial technological advancement. Developing a consistent and readily available source of renewable energy would provide the confidence needed to take a greater step out of fossil fuels and would open the door to a broader range of available renewable resources.

The ocean is a constant source of abundant energy. Although not as widely studied as other sources, marine energy is manifested in a variety of forms such as the movement of waves, the circulation of currents below the surface, the thermal gradients, and the large winds that blow across the surface. The goal of this project is to develop a method of capturing wave energy through a point absorber or buoy type device that moves with the oscillation of waves and converts that movement into usable power. In this report, the device designed to accomplish this goal and its development will be reviewed, and its primary mechanical analyses and power harvesting efficiency will be presented and discussed.

2. Scope

This project was conducted through the Senior Design course series in the Mechanical Engineering department which took place during the Winter and Spring quarters of 2017. The work done was a product of the Senior Design team EPA-1. This report summarizes the entire team's project and its outcomes. While the product that was developed was a concept that I had originally offered to the team for review and selection, the final design of the device and its prototype had equally shared design contributions from each member of the team. However, the work that I solely contributed was the theory found in **Sections 4** and **5** and the analysis found in **Section 8**. I was also the operator of the lathe in the team and produced all the parts that had to be turned, of

course with the help of the machine shop instructors when necessary. Additionally, I was one of two team members who worked on the solid modeling of the design and prototype using the Solidworks software.

3. Wave Energy Converter Design Solution

The design of this device was developed through a completed engineering design process consisting of seven steps. The first step of the process was the Recognition of Need. As shown in the introduction, the need of developing a reliable and efficient source of renewable energy was investigated and proved to be substantial and worthy of pursuit. Furthermore, ocean energy technology was specifically explored and was found to be facing several challenges prohibiting the widespread growth of the industry. These challenges are the high cost per wave energy converter (WEC) device making it uncompetitive with other alternatives, the need to double the energy production of each device to make it competitive, the lack of testing facilities with controllable wave environments, and the minimal amount of scientific data on the environmental conditions surrounding the deployment of a WEC [11].

The second step was the Problem Definition. With the need being so broad, the work in the Problem Definition aimed to narrow down exactly what our team wanted to accomplish. The problem statement that was generated was, “To create a novel apparatus that is able to efficiently transform the kinetic energy from waves into usable, low cost electrical energy.” At this stage, several parameters were set for the project. To summarize these briefly, the primary performance parameter was for the device to generate 500W, the intended customer would be isolated island or coastal communities without access to a grid, the environmental parameter was that the device needed to

withstand the destructive forces of the ocean waves and corrosive effects, and the final requirements were that the device needed to be small enough not to detract from the ocean's visual appeal and aesthetics of the ocean and that the marine habitat would not be disturbed or harmed by the device.

A Conceptualization design phase was conducted and eleven viable concepts were generated employing a variety of brainstorming techniques. Next, using a decision matrix with a list of weighted criterion such as feasibility, cost, maintainability, etc., the final design with the highest score was selected as part of the Concept Selection phase. The selected concept was sketched and shown below (Fig. 1).

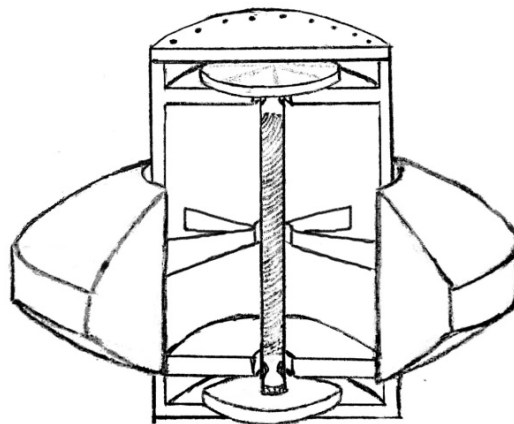

Figure 1. Concept Sketch of the Proposed WEC Device

The Embodiment Design that followed produced the full scale design which is thoroughly described in **Section 3.1**. The Detailed Design work followed as various analyses were conducted on the device. Finally, the Design Verification ensured that the working principles of the device operated correctly and the assumptions made in the design processes did not deviate substantially from reality. This was accomplished through the development and testing of a prototype.

3.1 Full Scale Design

3.1.1 Design Overview

The wave energy converter design selected for this project converts the vertical oscillations of wave motion into rotational energy using a threaded rod. The basic principle uses the reverse of a lead screw mechanism—a nut connected to a float travels linearly along a threaded rod that is fixed in all translational degrees of freedom and causes the rod to rotate about its longitudinal axis. Electrical generators attached to the ends of the threaded rod generate electricity by damping the rotational motion in a process similar to regenerative braking in electrical vehicles. The complete WEC design consists of three main sections which are the housing assembly, the float assembly, and the reference assembly as pictured below and are each described in the following subsections.

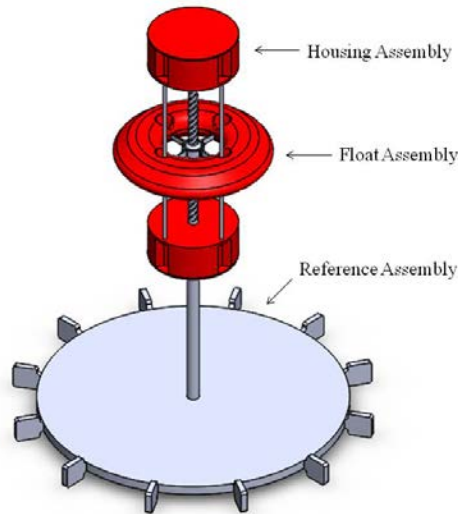

Figure 2. Complete wave energy converter design consisting of the reference, float, and housing assemblies.

The reference assembly system orients the housing structure of the device to where the lowest possible float position is at the lowest point of the wave cycle, the trough of the wave. This fixed position maintains the most length of the threaded rod in

the action potential region of the wave. When the water rises from its lowest trough position, the float then catches the wave and rises with the surface of the water while the rest of the housing remains stationary. At the center of the float assembly, a ball joint coupling connects to the threaded rod with a nut that transfers the linear upward motion of the wave into the rotation of the threaded rod. Support rods in the housing prevent the float from rotating around the threaded rod and maintain relatively strict linear motion. Rotational electric generators or dynamos are housed above and below the threaded rod and are connected to it through a one way clutch system. On the downward path of the float as the wave passes, the potential energy of the falling float will be used to generate power with the opposite dynamo while still maintaining resonance with the waves.

All the main structural components of this system will be built from protected steel in the final design using zinc or other anode characteristic material. This will ensure a longer lifetime in the highly corrosive ocean water environment. The float is the only component that will be made of a hard plastic material to increase its buoyancy and improve its effectiveness.

3.1.2 Housing Assembly

The primary function of the housing assembly is to provide a stable, fixed structure for the float to translate vertically without rotating. Additionally, the housing restricts the motion of the threaded rod solely to rotation about its longitudinal axis and orients the dynamo generators to capture that rotational energy while shielding them from the marine environment.

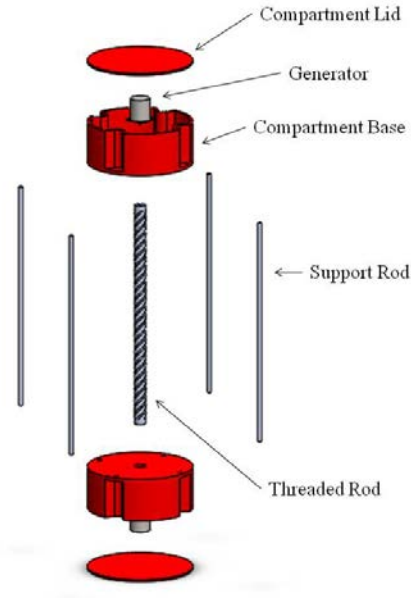

Figure 3. Exploded view of the general housing assembly showing the dynamo, the housing compartments, the support rods, and the threaded rods.

The housing assembly is comprised of two water-tight compartments on both ends of the threaded rod and four vertical support rods that firmly join the compartments. The two compartments contain the dynamos and other electronics responsible for electrical output and prevent the threaded rod from translating relative to the housing through the use of tapered roller bearings. The one way clutches that connect the dynamos to the threaded rods only allow dynamo rotation in one direction. This design will conserve any rotational momentum left in the dynamo and will avoid the motor wear caused by decelerating and reversing the motors with each cycle. The vertical support rods connect the two compartments and guide the float assembly up and down the length of the threaded rod while keeping the float from rotating. Alone, the housing assembly stands at 2.2 m measured from the opposite ends of the compartments. Below is a list of the primary components of the housing assembly and a brief description for each.

Threaded rod: This is a vertical metal rod with an outer diameter of 8 cm and four threaded grooves cut at 45°. It is restricted from translating in all directions and

forced to rotate about its longitudinal axis by the linear motion of the float to drive a dynamo generator.

Support rods: These are four identical rods that provide the structural support to the housing by joining the two compartments and fixing the threaded rod between them. It also gives stability to the float by limiting it to linear vertical motion.

Water-tight Compartments: These compartments are located at the top and bottom of the housing assembly and each consisting of a base and a lid. They protect the dynamo generators and other electronics, attach to the support rods, and maintain the orientation of the threaded rod through tapered roller bearings that support axial and radial forces. The lids have a water-tight seal and allow access for maintenance.

3.1.3 Float Assembly

The purpose of the float assembly is to capture the upward motion of the wave and translate that motion to the threaded rod.

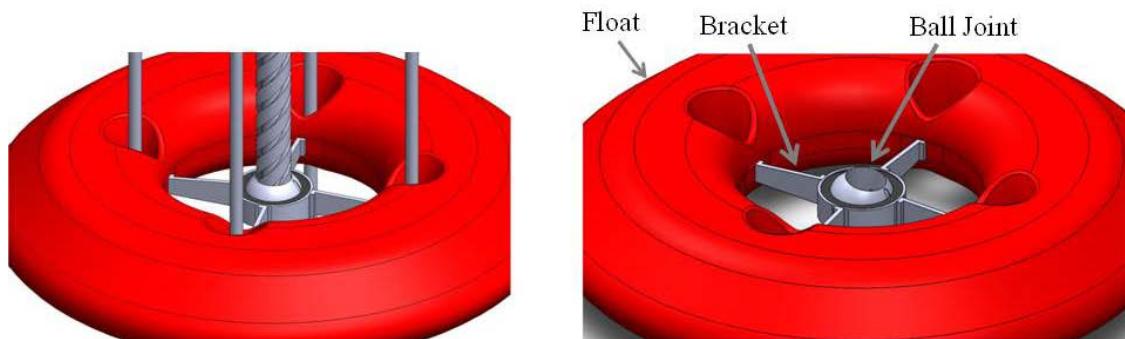

Figure 4. Float and ball joint mechanism assembly. The figure on the left shows the float assembly integrated with the rest of the components. The figure on the right shows the rotational freedom of the ball joint.

This assembly acts as a one dimensional point force on the threaded rod by connecting to it through a ball joint with a set of track wheels acting as the nut. The wheels follow the tracks or threads on the threaded rod and transfer the forces. Torsion about the threaded rod from the various angles that the wave may approach is avoided by

the ball joint allowing the float to tilt relative to the housing compared to a fixed or rigid connection. The ball joint (Fig. 5) is designed with a slot and groove mechanism which prevents the rotation of the ball about the vertical axis independently from the rest of the float assembly. This design allows the float assembly to tilt but ensures transfer of the forces linearly.

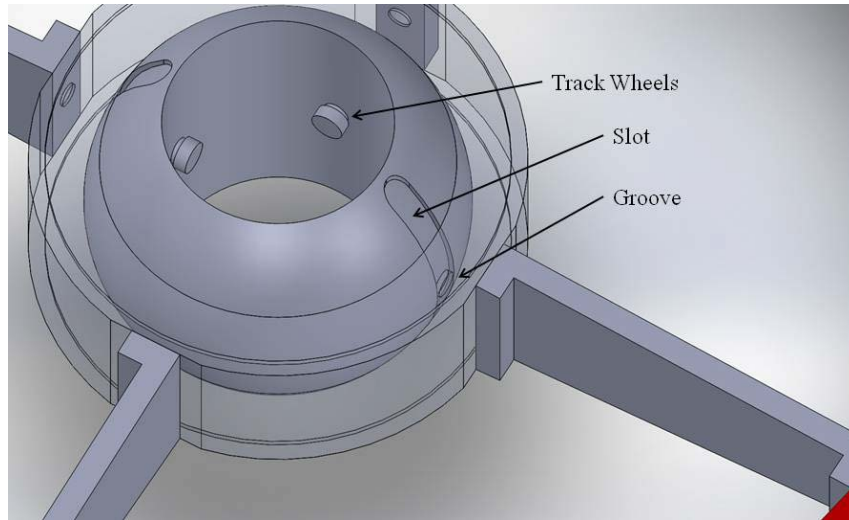

Figure 5. Ball joint mechanism showing the slot and groove design to prevent the free rotation of the ball about the vertical axis separate from the float.

Large holes with hyperbolic contours in the float allow its angular tilting motion without causing binding or significant resistance to the vertical motion against the support rods as the ball joint travels along the threaded rod. This motion can be seen in

Figure 6.

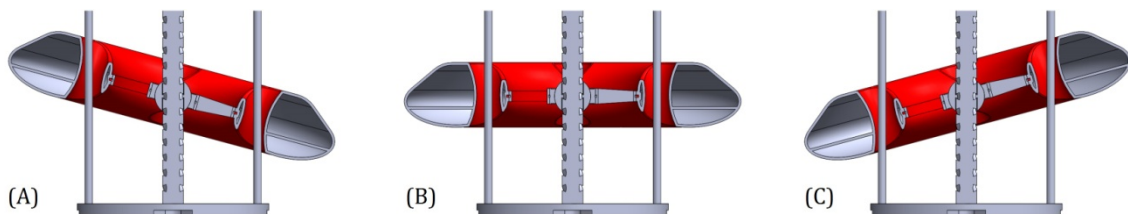

Figure 6. Float wave encounter succession is pictured here. The rotational freedom is shown in the contours enclosing the support rods. The water and air chambers seen in the float provide upward and downward motion.

Figure 6B shows the normal position of the float in flat water or at the crest of an ideal wave. Assuming a wave approaches from the left, the sequential orientations of the float are shown through **Figures 6A-6C**. For future work in the development of this device, careful consideration will be taken on the material selection to ensure a smooth, tough, wear-resistant material that can allow sliding against the support rods, but also sustain periodic knocking. Next, observe the divider shown in the internal cross-section of the float. The lower section, the water chamber, is filled with water and drives the float downward after reaching the crest of the wave using the potential energy of the elevated water mass. The upper section, the air chamber, uses the buoyancy of the air to push the float system upward during the rising of the wave while the lower water chamber is neutrally buoyant in the ocean water. The main components of the float assembly are listed below.

Float: This is a two chambered donut shaped device with four hyperbolic holes.

Ball Joint: This consists of an outer cuff and an inner ball that connects to the threaded rod. The outer cuff mates concentrically to the diameter of the ball and has a pin that fits in grooves on opposite sides of the ball preventing relative rotation about the vertical axis. Acting as the nut, the ball has a cylindrical cutout down its center close to the outer diameter of the threaded rod where wheels transfer force to the grooves/tracks of the threaded rod.

Brackets: These four brackets or arms connect the inner side of the float to the outer cuff of the ball joint and transfer the buoyancy forces of the float to the ball joint.

3.1.4 Reference Assembly

The reference assembly is used to maintain the housing assembly at a relatively fixed reference point for the float system to move with respect to. This requirement is twofold. First, this reference assembly must maintain stability for the system so it does not tip over. Second, the reference assembly must maintain the system at a constant height, unaffected by the wave motion, where the lowest point of the float on the threaded rod correlates to the lowest point or trough of the wave. While keeping the device perfectly fixed is impossible in the ocean, the main concept behind this design is to have this submerged reference body oscillate at an amplitude and phase different from the float to create the relative motion [7]. The two components of this assembly are the reference rod and reference plate.

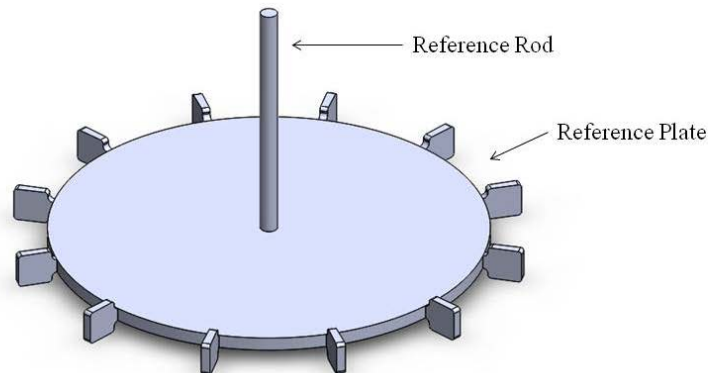

Figure 7. The reference assembly pictured here maintains a fixed point of reference to which the float can move. It consists of a connecting rod and a plate.

Reference Plate: This provides stability for the housing and float assemblies. Its inertia and drag restrict the housing from rising, falling, or tilting. The drag panels seen around the circumference of the plate dampen any rotational motion that might occur.

Reference Rod: Sometime referred to as a spar, this connects the housing assembly to the reference plate. This can have other functions such as provide buoyancy to the housing.

3.2 Prototype Design

This design initially caused some concern with our team's faculty advisors since typically, screw rotation is designed to cause linear motion and not the reverse. The concern held was that the friction angle of the screw would be too great and would prevent or cause very inefficient rotation of the threaded by the linear force of the nut. To verify this function, we developed a smaller scale prototype to test the functionality of our design.

The prototype was intended to function as closely as possible to the full scale design described in the previous section. Consequently, the objective was to construct the prototype with all the main components of each subassembly. After reviewing the total project, it was determined that designing and implementing the electronics of the system would be beyond the scope of this project with our limited time and budget. As an alternative to test the power capabilities of the device, a pulley-rope system was attached to a shaft connected to the threaded rod. This testing setup was designed to wind a rope around the shaft and lift a weight at the other end of the rope hanging off the side of the prototype. The testing process is explained further in **Section 7**. The reference assembly design was also beyond the scope of our project as the requirements for this system are very demanding and would need to be a separate project by itself to be done well. Thus, the prototype design was based on the assumption that the benefits of a reference

assembly were present and that the housing assembly was always positioned in its optimal orientation in the wave.

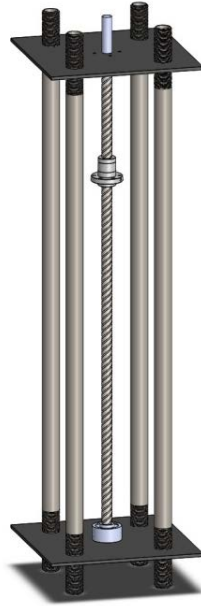

Figure 8. Prototype design without the float

3.2.1 Prototype Materials

The budget of this project was the main limiting factor in the construction of our design. Therefore, the prototype was initially designed based on materials which were readily available and affordable at local hardware stores and online suppliers like McMaster Carr. Fortunately, two companies donated some materials for our use which greatly reduced the cost.

Consisting of only the housing and float assemblies, the prototype stood a little over 40 inches. The housing compartments of the full scale design were replaced by flat $\frac{1}{4}$ in. thick steel sheets since no electronics had to be protected. The support rods were constructed from typical 1 in. diameter steel black piping used in construction. Twelve large nuts were used to anchor the support rods to the housing plates. Two tapered roller bearings were purchased and used to join the threaded rod to the housing plates. The

bearings were attached to the top and bottom plates with specially built bearing housings, and the threaded rod was attached to the bearings with specially built caps. A foam donut shaped float was used as the float. This prototype was only used to test the upward cycle so no water chamber was added. Other materials used were the pulley, paracord rope, and various types of fasteners.

The most expensive piece of the design was the threaded rod. Originally, since this complex part cannot be fabricated in the campus machine shop, we were going to use a 3D printer to make the threads of the rod in several hollow cylindrical segments and join these together with a long metal shaft through the center of the segments. However, with the high cost of each track wheel and concerns with resistance and misalignment between the wheels and the threads, we decided to find a ball screw that could achieve the same purpose. This was difficult since our project required a high thread helix angle for lower resistance. After contacting many vendors, a ball screw was found that fulfilled our requirements. This threaded rod had a diameter of 50mm and a lead of 20mm and cost just over \$400. Assembled with the threaded rod was a recirculating ball nut with 140 balls within it.

3.2.2 Prototype Construction

The most involved part of constructing the prototype was the work done in the machine shop. We received the metal plates as a long sheet of steel which had to be cut to the right dimensions for our project. The length of the support rods also had to be trimmed down. The diameter of the support rods also had to be cut down to a smooth surface and at the correct outer diameter for the 1 – 12 thread size we selected. Then, threads had to be precisely cut into the rods to allow the nuts to slide freely when

mounting to the top and bottom plates. Once the plates were cut to shape, they had to be milled precisely where the holes for the rods to fit through were needed. Also, holes were also milled for the attachment of the bearing housings and rod end caps. The bearing housings and end caps were turned on the lathe to a very close fit so there would be no clearance between the bearings and the caps and housings. After several days in the machine shop, these parts were completed and all assembled together. Marine grease was added to the bearing to protect the lubrication from water. The float was then attached to the ball nut through ropes which provided the same tilt freedom as a ball joint. At first, the ropes would loosen under loading until a better system was eventually developed but which provided a greater amount of resistance to the vertical motion of the float due to the high tension and friction around the support rods. The completed prototype is pictured below (Fig. 9). Further design details can be found in the **Appendix**.



Figure 9. Physical prototype with paint can acting as a weight to be lifted.

4. Wave Theory

Wave energy is a promising resource due to its high availability and its relatively easy accessibility. In comparison to solar and wind which are available only 20% to 30% of the time, waves are available 90% of the time at a given site [8]. To model the energy capabilities of a point absorber, an adequate understanding of the energy resources of a wave must first be established. Since wave forces are a highly complex hydrodynamic set of forces, many models have been proposed to explain this phenomenon. This paper will focus on a very basic model to provide a general and comprehensible understanding. Waves consist of both kinetic and potential energy [8,9]. The potential energy is observed in the upper half of the height of the wave crest that naturally wants to drop and become a flat pool. The kinetic energy at a minute level is displayed in small circular bobbing motions in the water [9]. At a macroscopic level, the kinetic energy is seen in the movement of the wave as it deforms the flat water surface into its wavy form and sends the water into the crest where it gains potential energy [7]. The speed of a wave, the velocity of the crest of a wave as it moves horizontally, is caused by the movement of the wind over the water [9]. This velocity is modeled by

$$v = \frac{gT}{2\pi} \quad (\text{eq. 1})$$

where g is the gravitational acceleration with a value of 9.81 m/s^2 , T is the period, and the wavelength $\lambda = vT$ [9]. The energy in the wave with this velocity is

$$P_{Total} = \frac{1}{4} \rho g h^2 v \quad (\text{eq. 2})$$

where ρ is the density of the sea water usually with a value of 1030 kg/m^3 and h is the total wave height, the distance from the crest to the trough, or twice the amplitude of the wave [7,8]. This model includes both the potential and the kinetic energy components of

the wave energy and gives a value in the form of power per unit length along the crest of the wave or along the shore [10]. This value typically ranges from 20-70 kW/m [10].

As a whole, the power of the waves hitting the coasts around the world is estimated to be 1 TW [7]. Looking at this power resource from a utility perspective, a report by the Department of Energy states that on the shores of the U.S. alone, there is a technical resource potential of 538-757 TWh per year of energy that can be generated [11]. Converting this value to intensity, ocean waves exhibit nearly 2-3 kW/m² while the available wind power is only 0.5 kW/m² [7]. Thus, the advantage of this vast amount of renewable power that is consistently available provides clear motivation to research and develop means to convert this consistent energy source to a usable form of power.

5. Device Power Potential

Since the prototype design featured the same main components and functionality as the full scale design, it was used as the basis of the analysis. Using the geometry, dimensions, and specifications of the prototype design, a preliminary power analysis was conducted to determine a basic power potential of our device. To model the system it is first necessary to identify the forces acting on the system. With the assumptions that the reference system holds the device in its optimal place, the force of

The interaction of the ocean waves with the buoy has been classically modeled in literature with the following equation

$$(m + a)\ddot{z} + b\dot{z} + cz = F_{PTO} + F_0\cos(\omega t + \sigma) \quad (\text{eq. 3})$$

Where $(m+a)$ is the total virtual mass of the buoy [12]. m is the mass of the buoy and a is the hydrodynamic coefficient of added mass which accounts for the inertia of the water surrounding the float [10]. b is the radiation damping coefficient related to the

damping of the float by the energy transferred to waves radiating away [10]. This term is often found through experimental results as it differs for each float system. c is the hydrostatic restoring force often considered as a type of buoyancy spring constant [10,12]. This term is defined as $\rho g S$ where S is the cross-sectional surface area of the float, ρ is the density of seawater generally known as 1030m/s^2 , and g is the gravitational acceleration [10]. F_{PTO} is the power-take-off force associated with the loading or resistance applied to the device by the generator or power conversion system. The final term of $F = F_0 \cos(\omega t + \sigma)$ is the excitation force from the waves characteristic of the wave properties [12]. This system reaches maximum power, P_{max} , when the oscillating float is in resonance with the wave [13.]. The power here is given as wave energy flux for linearized deep waves meaning it is expressed as power per unit length along the width or crest of the wave [10,13].

$$J = \frac{\rho g^2 T H^2}{32\pi} \quad (\text{eq. 4})$$

In this equation, ρ and g are the same as above. T is the period of the wave and H is the amplitude of the wave. Using this value of power, we can determine the power potential of our system if we assume it is in full resonance with the wave.

6. Device Mechanical Analysis

To understand the dynamic interactions of this device, a force analysis is first conducted to determine the net torque and force on the system.

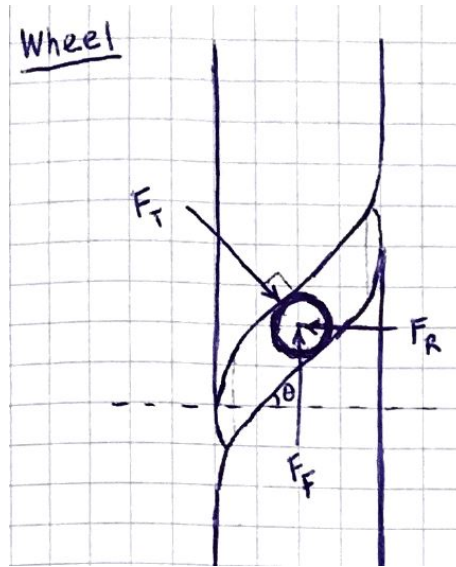

Figure 10. Free body diagram of a wheel or ball traveling through the threaded rod

F_T = Reaction force of the threaded rod on the wheel/ball

F_R = Component of the force on the wheel/ball due to the support rods of the housing

F_F = The vertical component of force on the wheel/ball caused by the float moving upward due to the buoyancy and upward motion of the wave

When viewing the free body diagram (FBD) of the wheel (or ball in the case of the prototype) in the threads of the rod, it is desired to maximize the magnitude of the force of the float, F_F , so that it is translated to the threaded rod while minimizing the force from the support rod, F_R , to reduce the stress in the support rod and the friction between the float the support rod. In this simple diagram, assuming that F_T , the reaction force of the thread on the wheel, is always perpendicular to the threaded surface, we can relate the forces in the following forms:

$$F_T = \sqrt{F_F^2 + F_R^2} \quad (\text{eq. 5})$$

$$F_F = F_T \cos\theta \quad (\text{eq. 6})$$

To maximize F_T , we need to minimize F_R so that most of F_F can be used to generate energy.

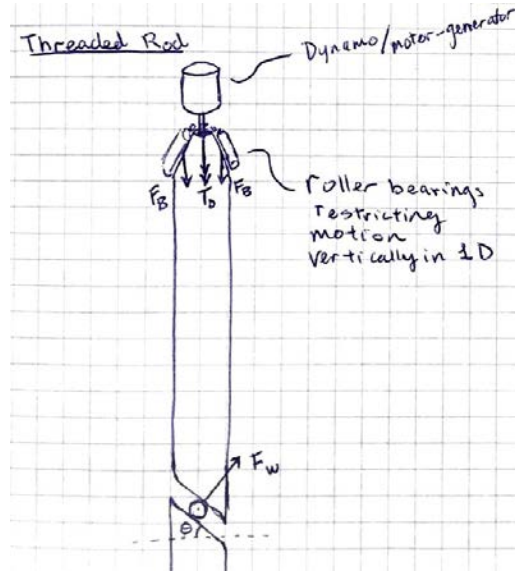

Figure 11. Free body diagram of the threaded rod

F_w = The force applied by the wheel/ball. It is equal and opposite to F_T

F_B = This is the force of the bearings preventing vertical translation of the rod.

T_D = The torque that the dynamo applies on the rod that is related to electrical output

θ = The thread angle of the rod.

Next, view the FBD of the threaded rod in **Figure 11**. The generation of energy comes from T_D , the torque applied by the dynamo generator that is directly responsible for the generation of electricity. The free body diagram of the rod demonstrates that T_D is a function of F_w and θ . They relate via the equation:

$$T_D = F_w R \sin(\theta) \quad (\text{eq. 7})$$

where R is the radius of the threaded rod. To maximize T_D and the electricity generated, θ must be maximized and F_B must be minimized because it is a non-conservative force like F_R . T_D depends upon $\sin(\theta)$ while F_B depends on $\cos(\theta)$ in the following equation:

$$F_B = F_W \cos \theta \quad (\text{eq. 8})$$

Thus, to both minimize F_R and F_B and maximize T_D compromise must be made for the value of θ . We will therefore assign θ a value of 45° between the two extremes.

The relationship between the force of the float caused by buoyancy, F_F , and the usable torque generated, T_D , can be solved for the by combining **Equations 6** and **7** and using the relationship that $F_W = F_T$. The resulting relationship is shown below.

$$T_D = F_F R \tan \theta \quad (\text{eq. 8})$$

Since a thread can be modeled as a ramp in 2D, the geometry of a thread can be depicted as in the figure below.

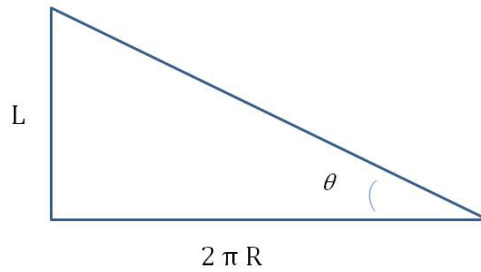

Figure 12. Triangle depicting the wedge model of a thread

L is the lead of the screw and $2\pi R$ is the circumference of the screw. With this model and solving for $\tan(\theta)$, we can write the final relationship as follows.

$$T_D = F_F \frac{L}{2\pi} \quad (\text{eq. 8})$$

7. Experimental Setup

To test our prototype, we loaded our device with a weight and simulated the motion of the waves in a swimming pool. Testing in the ocean was considered, but the logistics of renting a boat or the permitting process or using a pier made this more realistic test unfeasible. To test the device, one person stood in the water and held the

bottom of the prototype. Another person stood on the ground above the pool and stabilized the top of the prototype. Several different weights were used in to load the system.

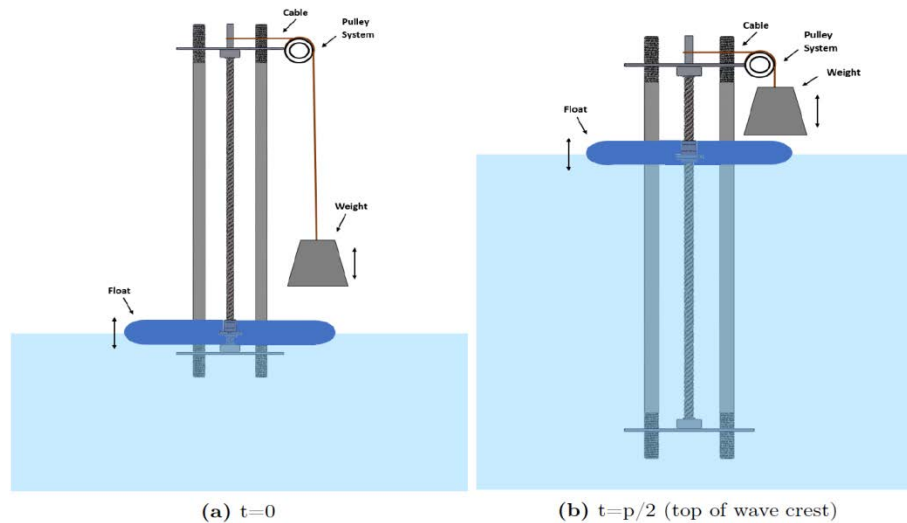

Figure 13. Prototype Testing Schematic. (a) shows the initial position at the wave trough and (b) shows the position highest position at the wave crest after half the period

In the test, the housing was lowered in to the water while the float remained stationary at the water's surface. The timing of the movement was recorded, and care was taken to ensure the duration of the movement was about half of a real wave period or about 5 seconds. Additionally, the distance the float traveled during that duration and the distance the weight traveled were also recorded. This testing was performed several times with different weights and timings.

This test proved to be difficult since the weight of the housing and the loading were very challenging to control with limited human strength especially since the weight hanging off one side caused a significant misbalance.

8. Results and Discussion

The results of this experiment proved that the functioning principles of back driving a lead screw mechanism can be successfully accomplished. The buoyancy of the float did, in fact, cause a lifting of the weight under loaded conditions and functioned as expected. The actual results of the experiment were taken from the test case with the most loading. The results are shown in **Table 1**.

Variable	Value
Half Period (T/2)	4.5 s
ΔH Float	13.5 in (0.3429 m)
Δh Weight	15 in (0.381 m)
Mass of Weight	50 lb (222.41 N)

Table 1. Test Result Data

The efficiency of the device can be evaluated by comparing the power of lifting the weight with the power in the “wave” using **Equation 4** and changing the resulting flux value into power by multiplying the width of the “wave” the device covered. Using the simple relationship of $P = Fv$, the power of the device was 18.83 W. Next, using the wave flux equation and converting it to power, the power of the simulated wave was estimated as 119.26W. Thus, the efficiency of the device was 15.79%. Due to the many faults of this type of test, this value is not very reliable. However, if it provides a base line measurement by which the device can be ranked.

There are several the errors that will need to be addressed for the test to improve in accuracy. First, the test is inherently flawed since the “power” of the wave is a function of the strength of the operator to push the housing into the water and lift the weight and may not realistically simulate the wave dynamics and interaction with the device. Also,

the power of the device that is calculated from lifting the weight is also incorrect since the weight really only moves a few inches upward relative to the ground, thus, not accounting for a significant change in inertia or change in potential energy. The change of height of the weight and the float were calculated from their change in distance relative to the housing which would only be accurate in a real wave environment. Furthermore, the ropes attaching the float to the nut sagged during the testing and dragged excessively against the support rods. The accuracy of measurement was also low since definitive start times and end times were difficult to determine due to the variation in the instantaneous velocity of the housing descending into the water. These errors are quite significant and a revised testing system will be needed to get better results.

9. Conclusion and Future Work

The successful development and operation of the wave energy converter device developed in this project shows great potential for its future commercial implementation. The baseline efficiency of 15% is a positive result considering it is an initial test and can be easily improved. Additionally, in comparison to solar panels which have a power density of 150 W/m^2 , our prototype device displayed a 43.79 W/m^2 power density [14]. Since the prototype model that was evaluated is a scaled down version of the full scale design, it is expected that the full design will be able to produce the desired 500W. The increase of float size and threaded rod length will allow the system to harness much more energy without expanding the area significantly increasing its power density and making this energy source competitive for commercial use.

While the prototype functioned appropriately in the experimental conditions, several immediate factors should be amended for the construction and testing of the

prototype in the near future. First, in reviewing the construction of the prototype device, three recommendations can be made. First, the lengths of the threaded sections on the top and bottom of the support rods were purposefully excessive for a safety margin but this caused difficulty constructing the device. The 1-12 threaded nuts that keep the top housing plate in position took a significant amount of time and effort to thread all the way. Additionally, the threads on the rods which were turned on the machine shop lathe were slightly rough making the threading of the nuts more difficult. The donated black piping used as the support rods were noticeably bowed and made aligning the rods with the holes in the housing plate a significant challenge. Therefore, better quality materials should be used for the support rods and the length of the threaded sections should be reduced. Additionally, the clearance holes in the top housing plate that the rods protruded through should have been made larger to account for this difficulty. Secondly, the testing of the device revealed weakness in the rope used to attach the float to the ball nut. A different approach should be taken for the next test where greater tension is applied in the ropes. Alternatively, a solid connection such as metal rods should be used in place of the ropes. Finally, a better weight system to test the power capabilities of the prototype should be found since the current system had some interference with the movement of the float. To get more accurate results, a camera mounted on the top housing plate will record the exact distance and velocity traveled by the weight by observing the number of revolutions of the shaft.

Based on the testing of the prototype, some recommendations and future work for the full scale design are now presented. The first improvement includes changing the wheels in the nut of the full design to a ball screw. After observing the excellent

performance of the ball screw to seamlessly transfer the linear forces to the rotational motion of the threaded rod, it was apparent that the same design should be used in the full scale design. To improve the testing process of the device, a testing facility that generates wave motion should be used to produce much more accurate and realistic results. Furthermore, an electrical loading system, like a generator, should be developed and used to measure the power in the testing. This will develop the process closer to its intended final use. To maximize the power production, a control system will also need to be developed to keep the system in resonance with the wave. This control system will measure the torque and rotation of the threaded rod and vary the electric loading on the generators. The control system will also need to change the mode of operation when storm conditions arise and load the system. A reference system will also need to be developed which can accommodate for the rising of the tides but still maintain the housing at its optimal position. Finally, a system for easy maintenance and monitoring of the system will need to be developed in the future as testing progresses into the actual ocean environment.

Once development of the device has reached an acceptable position, a system of farming or arraying a series of devices can be investigated to multiply the power generated by this technology. With the immense power density of waves all along our coasts, successfully harvesting this consistent energy will have a huge impact on the renewable energy sector. Although this technology may not be ready for implementation by the SB 100 deadline, it will certainly be a large contributor to future coastal energy needs where the demand is greatest.

REFERENCES

1. Turns SR. An Introduction to Combustion: Concepts and Applications. 1996. Oxygen-Enhanced Combustion.:543.
2. Table 1.3. Primary Energy Consumption by Source. Annual Energy Review. U.S. Energy Information Administration (EIA). 2017. Available from https://www.eia.gov/totalenergy/data/monthly/pdf/sec1_7.pdf
3. California Moves Closer to 100% Clean Energy. Senate District 24, Kevin De Leon; 2017 May 31. Available from <http://sd24.senate.ca.gov/news/2017-05-31-california-moves-closer-100-clean-energy>
4. Cahill N. California Lawmaker Wants All Green Energy by 2045. Courthouse News Service; 2017 May 2. Available from <http://www.courthousenews.com/california-lawmaker-wants-green-energy-2045/>
5. Culliton T. Population: Distribution, Density and Growth. NOAA's State of the Coast Report. National Oceanic and Atmospheric Administration (NOAA). Silver Spring, MD: NOAA. 1998.
6. National Coastal Population Report: Populations Trends from 1970 to 2020. NOAA's State of the Coast Report. National Oceanic and Atmospheric Administration (NOAA). 2013 March. Available from <http://oceanservice.noaa.gov/facts/coastal-population-report.pdf>
7. Falnes J. A review of wave-energy extraction. Marine Structures. 2007 Oct 31;20(4):185-201.
8. Pelc R, Fujita RM. Renewable energy from the ocean. Marine Policy. 2002 Nov 30;26(6):471-9.
9. MacKay DJ. Sustainable Energy—without the hot air. UIT Cambridge, England. 2009.

10. Antonio FD. Wave energy utilization: A review of the technologies. *Renewable and sustainable energy reviews*. 2010 Apr 30;14(3):899-918.
11. Orr FM. 2015 Quadrennial Technology Review. In *Proceedings of the International Conference for High Performance Computing, Networking, Storage and Analysis* 2015 Nov 15. ACM.
12. Agamloh EB, Wallace AK, von Jouanne A. A novel direct-drive ocean wave energy extraction concept with contact-less force transmission system. *Renewable Energy*. 2008 Mar 31;33(3):520-9.
13. Li Y, Yu YH. A synthesis of numerical methods for modeling wave energy converter-point absorbers. *Renewable and Sustainable Energy Reviews*. 2012 Aug 31;16(6):4352-64.
14. Raghunathan V, Kansal A, Hsu J, Friedman J, Srivastava M. Design considerations for solar energy harvesting wireless embedded systems. In *Proceedings of the 4th international symposium on Information processing in sensor networks* 2005 Apr 24 (p. 64). IEEE Press.

APPENDIX

Detailed Component and Assembly Drawings for the Prototype

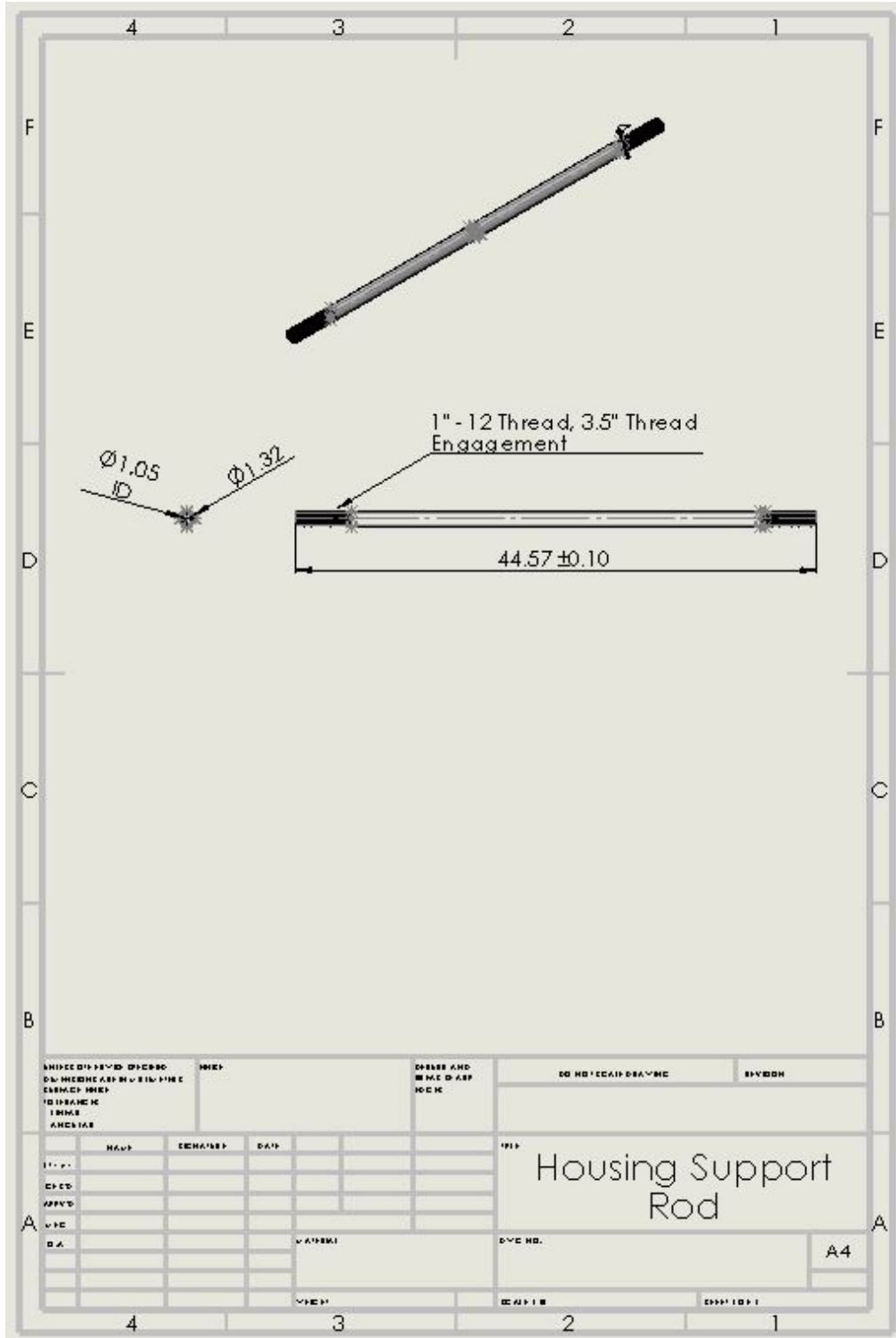

Figure 14. Prototype Housing Support Rod Drawing

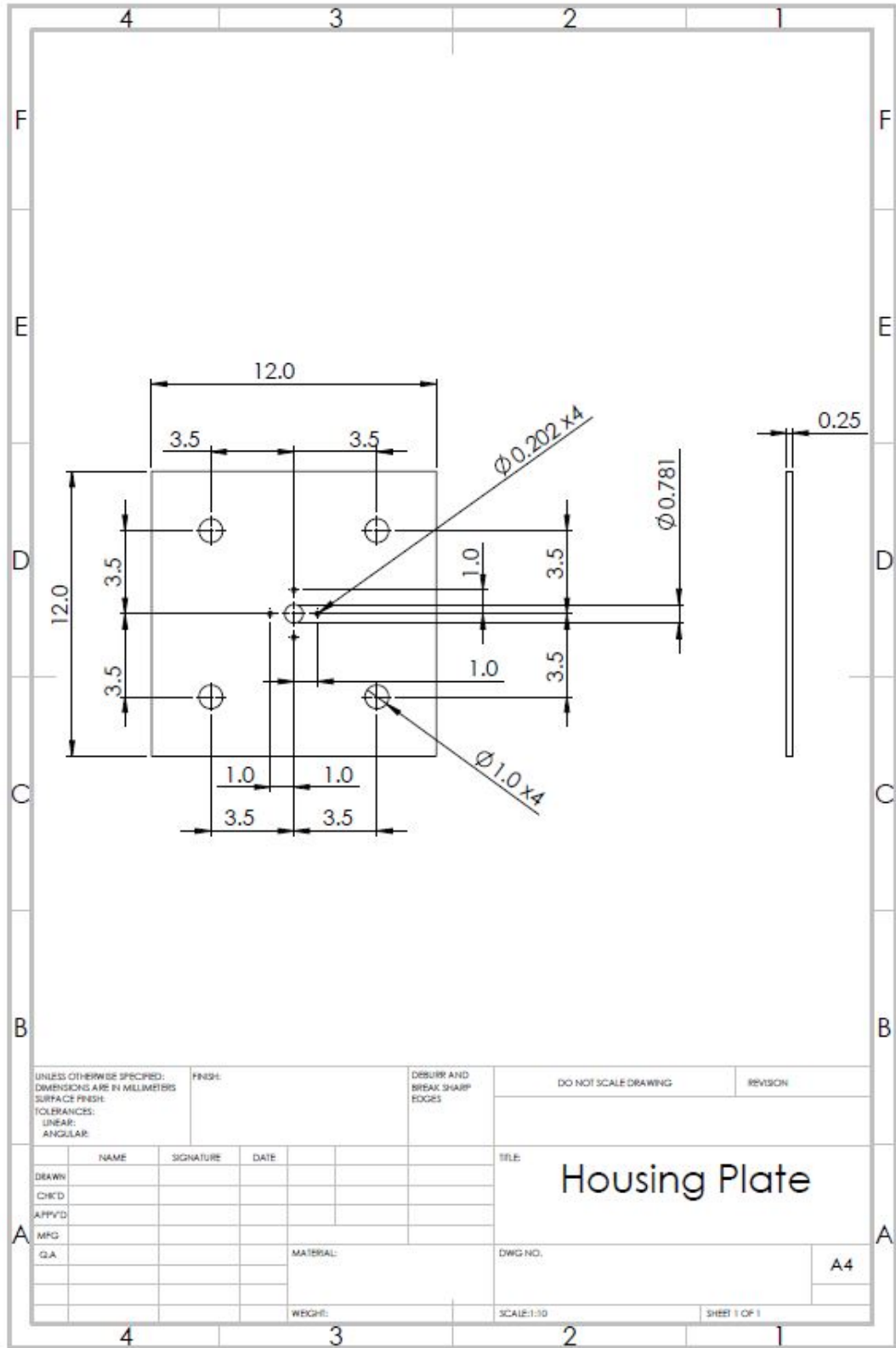

Figure 15. Prototype Housing Plate Drawing

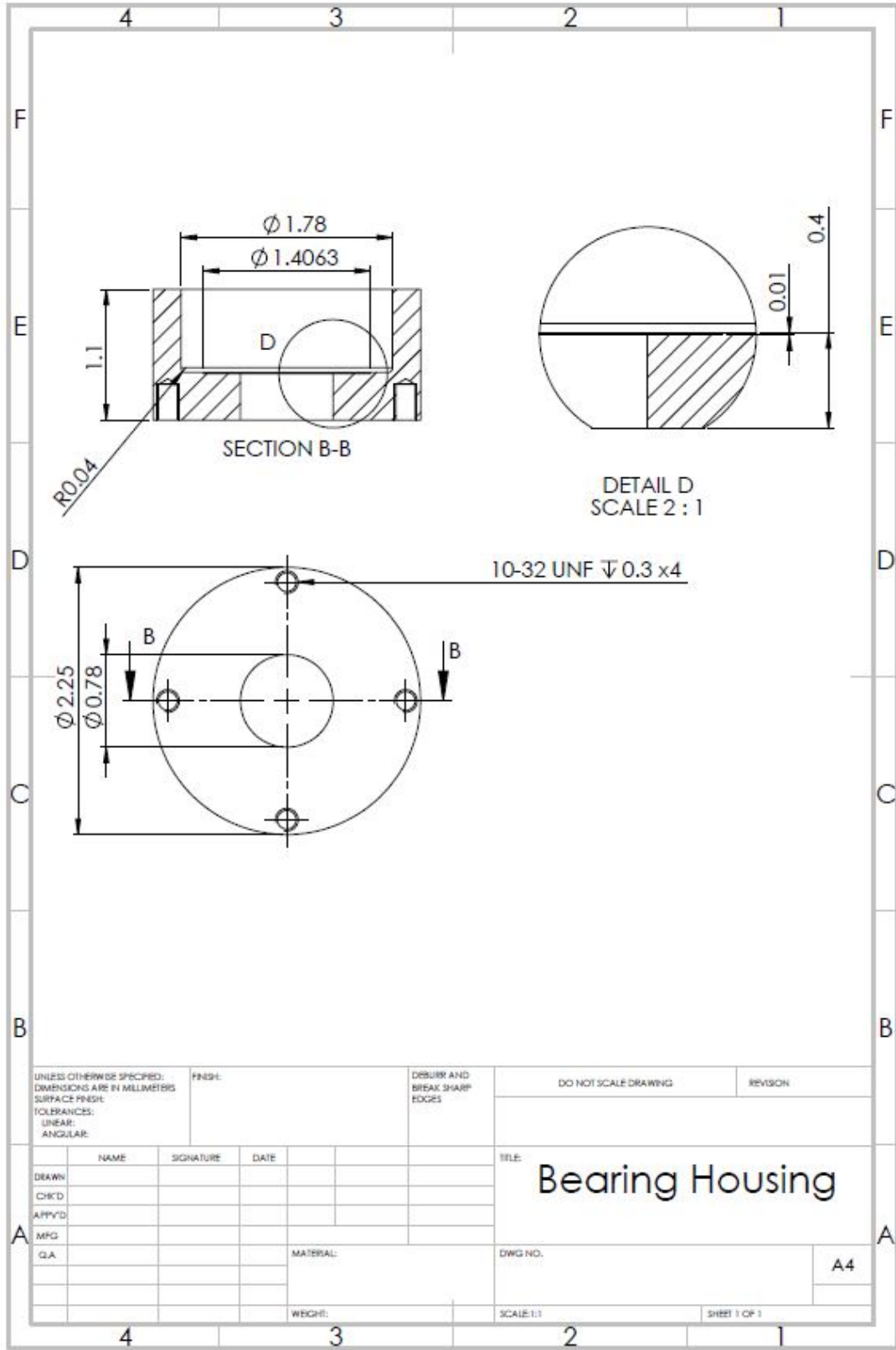

Figure 16. Prototype Bearing Housing Drawing

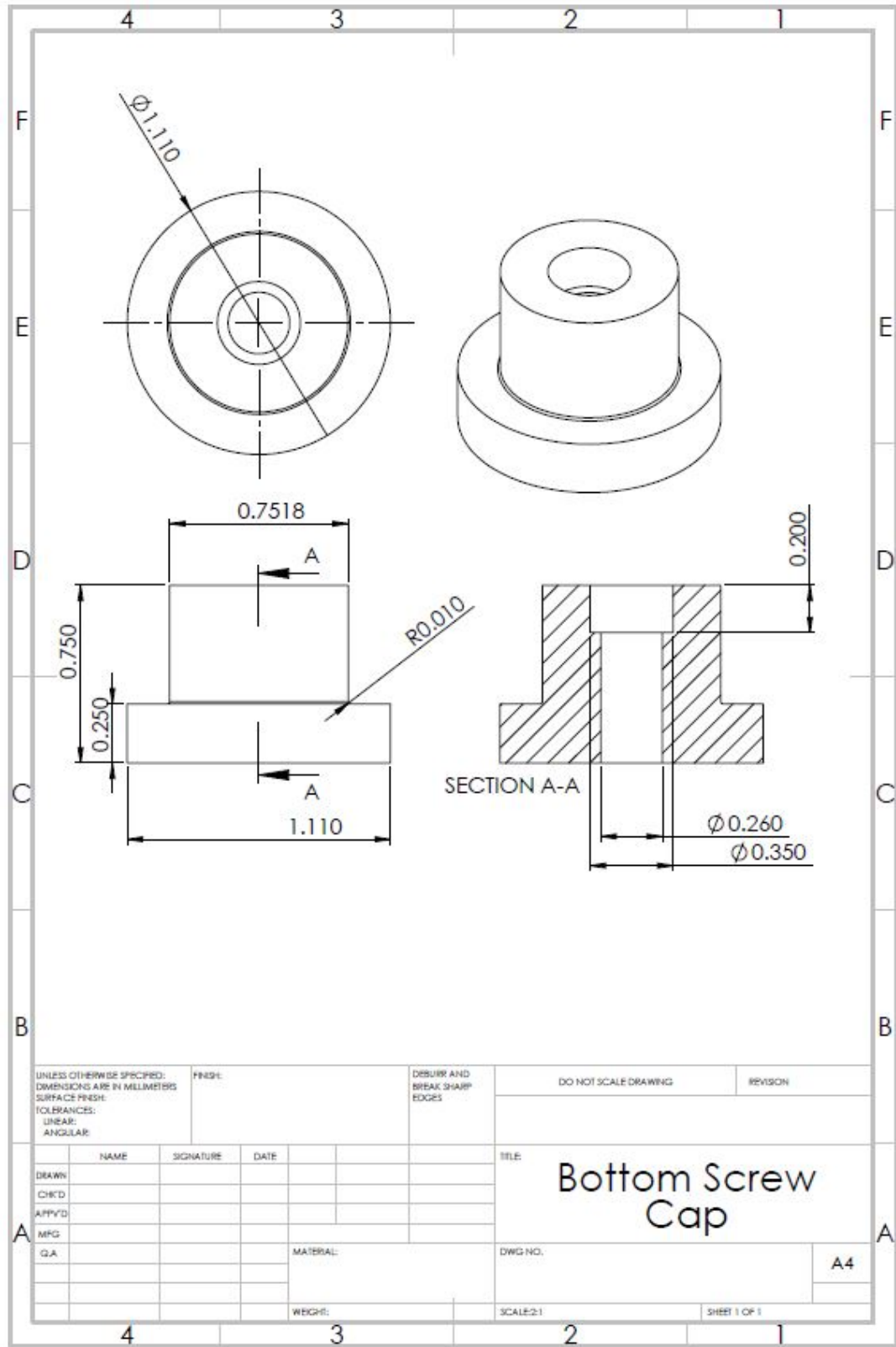

Figure 17. Prototype Bottom Screw Cap Drawing

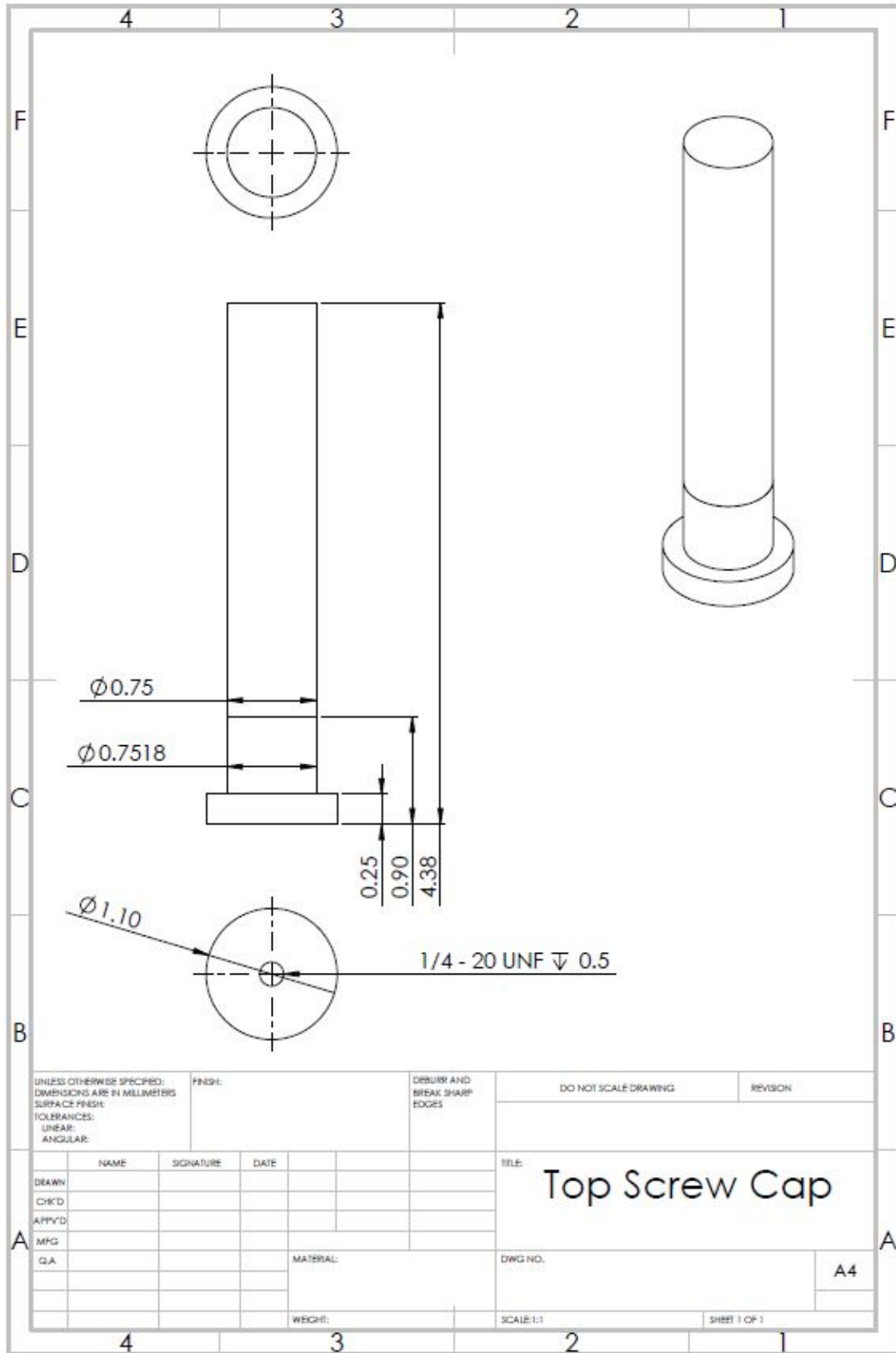

Figure 18. Prototype Top Screw Cap Drawing

Part Name	Price/Part	Donation Source	Vendor	Quantity	Total Price
Ball Screw/Nut Assembly	\$401.70	BCOE	Motion Industries	1	\$401.70
Size 1 Piping 10ft.	\$0.00	JT Thorpe & Son, Inc.	JT Thorpe & Son, Inc.	2	\$0.00
1/4" Steel Plating-12"x12"	\$0.00	JT Thorpe & Son, Inc.	JT Thorpe & Son, Inc.	3	\$0.00
Steel Tapered-Roller Bearing	\$18	KG International FZCO	McMaster-Carr	2	\$36.94
1" - 12 Hex Bolt	\$4.14	KG International FZCO	Rainbow Bolt & Supply	12	\$49.68
#10 - 32 Machine Screws	\$0.10	KG International FZCO	Rainbow Bolt & Supply	8	\$0.80
Thread Locker	\$6.35	KG International FZCO	Rainbow Bolt & Supply	1	\$6.35
Pulley	\$19.99	KG International FZCO	Amazon	1	\$19.99
1/4" - 20 Stud	\$2.10	KG International FZCO	Lowe's	1	\$2.10
1/4" - 20 Bolt and Nut (4 pack)	\$1.20	KG International FZCO	Lowe's	1	\$1.20
Marine Grease	\$6.48	KG International FZCO	Lowe's	1	\$6.48
Paracord 5/32" 30 ft. Long	\$4.20	KG International FZCO	Lowe's	1	\$4.20
Aluminum Rods	\$4.86	KG International FZCO	Industrial Metal Supply Co.	1	\$4.86
				Total	\$534.30

Table 2. Prototype Bill of Materials