

UC Davis

UC Davis Previously Published Works

Title

The Effect of Friction on Actuation Torques of Foldable Rollover Protective Structures.

Permalink

<https://escholarship.org/uc/item/1814n10k>

Journal

Journal of Agricultural Safety and Health, 24(4)

ISSN

1074-7583

Authors

Khorsandi, Farzaneh

Ayers, Paul

Publication Date

2018

DOI

10.13031/jash.12844

Peer reviewed



HHS Public Access

Author manuscript

J Agric Saf Health. Author manuscript; available in PMC 2020 July 27.

Published in final edited form as:

J Agric Saf Health. 2018 ; 24(4): 227–242. doi:10.13031/jash.12844.

The Effect of Friction on Actuation Torques of Foldable Rollover Protective Structures

Farzaneh Khorsandi,

Agricultural Safety and Health Engineering Assistant Specialist in Cooperative Extension,
Department of Biological and Agricultural Engineering, University of California, Davis, California

Paul D. Ayers

Department of Biosystems Engineering and Soil Science, University of Tennessee, Knoxville,
Tennessee.

Abstract

The number of fatal tractor rollover accidents with an inoperative foldable rollover protective structure (FROPS) has increased sharply in recent years. Operators frequently leave the FROPS in the folded-down position after lowering the FROPS to pass a low overhead obstacle. One possible explanation for leaving the FROPS in the folded position is that raising and lowering the FROPS is a time-consuming and strenuous process. The actuation torques required to raise and lower a FROPS are not well known and may be influenced by friction. The actuation torques of ten FROPS from four different models were measured. One model FROPS was tested on seven different vehicles, and three models were tested separately. The dynamic and static (initiation and holding) actuation torques were measured to evaluate the effect of static and kinetic friction on actuation torque. The dynamic actuation torques were measured before and after greasing the FROPS. The proposed instruction to measure the actuation torque based on OECD Code 7 was evaluated. Results showed that friction has a significant effect on the measured actuation torque and can increase the actuation torque by up to 212%. The friction varies between FROPS of the same model, which is due to variations in the manufacturing, maintenance, and age of the FROPS. The friction force could be decreased by greasing the FROPS, and decreasing the friction increased the lowering resisting torques and decreased raising torques of FROPS. The measured actuation torque based on OECD Code 7 instruction (static holding) is not a constant value. The dynamic method is recommended for measuring FROPS actuation torques.

Keywords

Actuating torque; Foldable rollover protective structure; FROPS; Safety; Standards; Tractor

The Bureau of Labor Statistics reported agriculture as one of the most dangerous industries in the U.S. (BLS, 2016). Fatalities among agricultural workers were 286 cases in 2015, which increased by 25% compared to 2014. Tractor accidents are the leading cause of death in agriculture, constituting half of the fatalities (Hoy, 2009). Murphy and Buckmaster (2014)

reported rollover accidents as the most frequent type of fatal tractor accident. Tractor rollover accidents result in one-third of fatal tractor accidents (Murphy and Buckmaster, 2014).

Tractor rollover accidents occur in a matter of seconds, which is a short time for an operator to make an appropriate decision and escape the scene. The most effective way to survive a tractor rollover accident is with combined use of a rollover protective structure (ROPS) and properly fastened seatbelt. The survival chance of an operator in a rollover accident in a tractor with a ROPS and wearing a seatbelt is 99% (Murphy and Buckmaster, 2014). Based on a National Institute for Occupational Safety and Health (NIOSH) report, the number of fatal tractor accidents could be decreased by 71% if all tractors were equipped with ROPS (Myers, 2009). However, in 2012, only 59% of agricultural tractors were equipped with ROPS.

Several ROPS design programs have been developed to design appropriate ROPS for tractors (Ayers et al., 2016). ROPS installation decreases the number of fatal tractor rollover accidents. Spielholz et al. (2006) reported overhead obstacles as the primary cause for operators not installing ROPS. The foldable ROPS (FROPS) has been designed to address the overhead clearance problem. Based on OSHA (2013), the operator can temporarily fold down the FROPS to pass through low overhead clearance zone. The FROPS should be raised as soon as the vehicle exits the low overhead clearance zone. However, operators frequently leave the FROPS in the folded-down position, mainly due to the inconvenience of manually raising the FROPS (Myers, 2015). A folded-down FROPS does not provide adequate protection for the operator Martin (2017). Raising and lowering a FROPS is a strenuous and time-consuming procedure. For example, for an Exmark Z-Series lawnmower, raising and lowering the FROPS includes 28 steps and requires 88 seconds (Froula et al., 2016).

The percentage of fatal rollover accidents with folded-down FROPS compared to total rollover accidents has increased sharply in recent years. Ayers et al. (2018) reported that this percentage rose from 0% to 50% from 2003 to 2010 in the U.S. In Europe, 40% of fatal rollover accidents occurred while the FROPS was in the folded-down position (Hoy, 2009).

Based on OECD Code 7, the actuation forces required to raise and lower rear-mounted FROPS on narrow-track tractors should not be higher than 100 N (OECD, 2017). Pessina et al. (2016) measured the actuation forces required to raise and lower 19 different FROPS using a handheld force gauge at five angles (0°, 30°, 45°, 60°, and 90°) with respect to the ground plane. The force was measured at a 1520 mm distance from the ground surface, when the FROPS was in the upright position. The results showed that the actuation forces for nearly all the FROPS were greater than the 100 N, which is higher than the OECD criterion. In that study, only the static holding forces were measured. Static force was measured while the upper part of the FROPS was held at certain angles. The influence of the rotational speed and friction on actuation force was not investigated.

Khorsandi et al. (2016) measured the torques required to actuate FROPS. The actuation torque is a function of inertial forces (I), friction force (F), and the weight (W) of the upper part of the FROPS. Results of their study showed that the actuation speed had significant (p

< 0.05) effects on the actuation torque, but the difference between different levels of speed was small. Their study results also showed that the actuation torques for raising and lowering the FROPS with low friction are similar, but for FROPS with high friction, the actuation torques are greater for raising than for lowering. They reported that friction affects the actuation torques of the FROPS. However, there is no study evaluating the effects of a range of friction values on actuation torques.

In OECD Code 7, an instruction has been developed to measure the actuation torques of FROPS (OECD, 2017). It recommends holding the upper part of the FROPS at a certain angle and measuring the actuation torque, which is called static holding torque. In actual use, a tractor operator raises and lowers the FROPS without stopping, except at the end and the beginning. The measured actuation torque in this condition is called the dynamic actuation torque. Khorsandi et al. (2016) showed that there is a significant difference between the static holding torque and the dynamic actuation torque.

Materials and Methods

To examine the objective and the research hypothesis, a measurement setup was developed and was used to measure the actuating torques. The measurement setup included two sections: power and sensing.

Power Setup

The FROPS was raised and lowered using a power setup that included a motor, a fork, a stand, a switch, and a battery. The motor turned the upper part of the FROPS using the fork (fig. 1). The motor (model PM 8014-PL 731000, Groschopp) has a constant speed equal to 3.3 rpm (20 deg s⁻¹). This constant speed was selected based on the reported results of Ayers et al. (2016). The motor was mounted to the static part of the FROPS. A switch was used to control the direction of the reversible motor. The 12 V battery was used to supply the required power for the motor.

Sensing Setup

The sensing setup included an angle measurement sensor which is an accelerometer (model CXL04LP3, Crossbow), and a torque transducer (model TQ420-2K, Omegadyne). The angle sensor was attached to the upper part of the FROPS using a magnet. The magnet did not disturb the accelerometer performance. The torque transducer was attached to the fork and the motor to measure the actuation torques of the FROPS (fig. 1). The effect of fork weight on the measured actuation torques was subtracted from the torque transducer measurement. A data logger (model CR23X, Campbell Scientific) was used to record the output of the accelerometer and the torque transducer at 20 Hz.

Experimental Tests

The tests included raising and lowering ten FROPS with two levels of speed (dynamic and static) with multiple replications. The dynamic tests included two levels (with and without

greasing), and the static tests included two levels (holding and initiation). The static tests were done before greasing.

Ten used FROPS were selected from four different models of FROPS from vehicles including Snapper Pro, Gravely, Kubota, and Exmark. The actuation torques for seven similar FROPS on Exmark vehicles were measured and reported. Each test included at least three repetitions. The experimental test results included the static and dynamic actuating torques and the dynamic actuation torques after greasing. For greasing, lithium grease (LB8529, Loctite) was sprayed for 5 s (15 mg) between the pivot point plates, which were the only contacting surfaces in the FROPS and therefore the only source of friction.

Static holding torque was measured while the upper part of the FROPS was held at certain angles for at least 3 s, both for raising and lowering. As the FROPS started its transition from static to dynamic movement, a sharp change in the torque values around the measured initiation torque value was initially apparent. The initial value of the torque in this transient step was recorded as the static initiation torque. The static initiation torque was measured as the upper part of the FROPS was raised or lowered from a static position to a rotational speed of 3.3 rpm.

Table 1 shows the information about the vehicle models, FROPS labels, ROPS standards, and pinned angles of the FROPS. The ROPS standards include OSHA 1928.51 (OSHA, 2005) and ISO 21299 (ISO, 2009). Angles were measured with respect to the ground plane. The pinned angles include the angle of the upper part in the raised locking position (called up-locking) and the angle of the upper part in the lower locking position (called down-locking). The up-locking point is around $+90^\circ$, and the down-locking point is a negative value. The pinned angles were different for the same model of FROPS (Exmark) because there were some difference in manufacturing as well as some obstacles in the way of the FROPS as it was folded down.

There were differences between the up-locking and down-locking angles of the seven FROPS of the same model (Exmark). The vehicles were the same, but there were some differences between the Exmark FROPS designs, such as the shape of the pivot point plate and the upper part of the FROPS (fig. 2). Several of the Exmark vehicles (1, 2, 3, and 7 in table 1) were similar, but the other Exmark vehicles were different. There was also some difference in manufacturing, such as small inconsistencies in assembly and part size, as well as differences in maintenance, working conditions, friction, and age of the FROPS. In some cases, for the down-locking point, there were obstacles, such as a toolbox, that prevented the upper part of the FROPS from folding all the way down.

In this study, clockwise rotation (torque applied to raise the FROPS) is assumed to be the positive direction. Therefore, counter-clockwise rotation (torque applied to lower the FROPS) is negative (fig. 3).

Theoretical Model

The actuation torque (T) is a function of the friction moment (f), inertial moment (i), and weight moment (w) around the pivot point (fig. 2). A theoretical model was developed to

calculate actuation torque (TT) based on L1 and w, which is a function of L2, and W. The theoretical actuation torque (TT) was calculated using equations 1 and 2. The values of L2 and W were calculated using the FROPS dimensions, shape, and density. In the theoretical model, the effects of i and f were not considered. The effect of inertial forces on the actuation torque is negligible, except around the start and stop points, which were not evaluated in this study. Because the effect of weight on actuation torque can be measured and calculated accurately, the theoretical actuation torque was calculated based only on the weight. The theoretical actuation torque was used as a criterion to measure the effect of friction (f) on actuation torque (eq. 3):

$$F_{AT} = \frac{W \times L_2}{L_1} \quad (1)$$

$$T_T = F_{AT} \times L_1 = W \times L_2 = w \quad (2)$$

Friction percentage was calculated using equation 3:

$$\text{Friction (\%)} = \frac{T_E - T_T \times 100}{T_T}$$

The friction percentage shows how much friction contributed to the theoretical actuation torque. As shown in equation 2, the theoretical actuation torque is equal to the moment of the weight of the upper part of the FROPS. For example, 100% friction means that the effect of friction on the actuation torque is equal to the effect of weight on the actuation torque.

As in all experiments, there was some error in the measurements. The theoretical model was validated by comparing the calculated w based on the shape, dimensions, and density of the upper part of the FROPS and measuring the weight and CG location directly. The CG location was measured with the hanging method, and the weight was measured with a scale. The error in calculating w or TT compared to the measured w was less than 2%.

The actuation torque is equal to the product of the actuation force and the lever arm length (L1). The lever arm is the perpendicular distance from the axis of rotation (pivot point) to the line of the actuation force (fig. 2). The lever arm length is a constant value, as the actuation force is applied perpendicular to the upper part of the FROPS at the contact point of the fork with the upper part of the FROPS. The lever arm length (L1) is thus equal to the length of the fork (fig. 2). There is a linear relationship between the actuation torque and the actuation force (eq. 2); whatever affects the actuation torque also affects the actuation force, and vice versa.

The amount of friction for representative points was calculated using equation 3, and the results are presented in tables 2 and 3. The representative point for each FROPS is the angle at which the theoretical actuation torque has a maximum value. The maximum theoretical value of actuation torque occurs when the weight vector is vertical and perpendicular to the torque arm, which happens when the torque arm is horizontal. The torque arm is the line that

attaches the CG to the pivot point of the upper part of the FROPS (dashed line in fig. 2). The representative point for all FROPS was at the peak point, except for the Gravely and Exmark 6 vehicles. For those two cases, the FROPS did not produce a defined peak angle, and representative points at 20° and 10° were selected for Gravely and Exmark 6, respectively. The representative point should be far from the down-locking and up-locking points because the inertial forces are not negligible around those points.

Results and Discussion

In this study, three types of actuation torque were measured for ten FROPS to assess the proposed objectives. The measured actuation torques included dynamic, static initiation, and static holding (figs. 4 through 10). Results for dynamic torque (before and after greasing), static initiation torque, and static holding torque of the ten FROPS were presented by Khorsandi (2017). The dynamic actuation torques were measured before and after greasing the FROPS (figs. 6 and 9). The experimental test results were compared with the developed theoretical model results to measure the effect of friction on actuation torque.

The dynamic actuation torques of ten FROPS were measured, and the results for raising and lowering were compared to determine the kinetic friction for each FROPS. Results for some representative FROPS are shown in figures 4 through 10. The static holding actuation torques for raising and lowering were measured and compared to quantify the static friction. The static initiation torques were measured to evaluate the effect of inertial forces and kinetic friction on actuation torques. In addition, results of two static torques (holding and initiation) were compared to evaluate the proposed instruction to measure the actuation torque based on OECD Code 7. Actuation torques for four models of FROPS were measured to show how friction varies between different models of FROPS. Actuation torques for seven FROPS of the same model were measured and compared to show how actuation torques are dissimilar among the same model of FROPS.

Dynamic Actuation Torques

The measured dynamic actuation torques of three FROPS of two models are shown in figures 4, 7, and 10. The dynamic actuation torques comprised of fK , i , and w . Results showed that there were some differences between the dynamic actuation torques required to raise and lower the FROPS (figs. 4, 7, and 10). These differences were mainly due to friction.

The effects of inertial forces (I) on actuation torque are more significant at the up-locking and down-locking points. At these points, there is a sharp change in the turning speed when reaching the limits of movement. Except for these two points, the turning speed is constant. There is a change in the direction of the velocity vector, which causes a centrifugal acceleration and consequently I . The moment of this centrifugal inertial force is zero, as the torque arm for this force is equal to zero.

The value of w is negative for both raising and lowering the FROPS, but fK is negative for raising and positive for lowering the FROPS (fig. 3). Therefore, $w + fK$ is equal to the actuation torques for raising the FROPS because w and fK are in the same direction for

raising. However, fK and w are in reverse directions for lowering the FROPS; therefore, $w - fK$ is equal to the actuation torque for lowering the FROPS. The difference between the actuation torques required to raise and lower the FROPS is twice the fK at each point. The theoretical line represents w . The theoretical line plus fK is equal to the actuation torque for raising, and the theoretical line minus the fK is equal to the actuation torque for lowering the FROPS.

The coefficient of friction on uneven surfaces can be dissimilar in different directions. Consequently, the friction values in raising and lowering are dissimilar for the same FROPS. Because the FROPS in this study were used and old, there were scratches, corrosion, and small particles and dirt on the metal surfaces that caused differences in friction in different directions. In some cases, such as the Kubota, Exmark 4, and Exmark 5, the friction for lowering was higher than the friction for raising. For other cases, the friction was higher for raising than for lowering (tables 2 and 3). Because the source and amount of friction for the FROPS were dissimilar in different directions, the effects of greasing on the different surfaces and directions were different.

Figure 4 shows the dynamic test results for a FROPS with low friction. When the friction is low, there is a small difference between the raising and lowering actuation torques. In tables 2 and 3, the FROPS with friction of about 10% are considered FROPS with low friction, as there is a small difference between the actuation torques required to raise and lower the FROPS. The Gravely and Exmark 1, 2, and 3 are considered FROPS with low friction. Figure 7 shows the dynamic test results of a FROPS with medium friction. A medium friction FROPS has a friction between 10% and 100%. A high friction FROPS has friction higher than 100%, and f is higher than w . There is a considerable difference between the raising and lowering actuation torques, but the lowering actuation torque is mainly positive. The Kubota and Exmark 4, 5, and 7 are FROPS with medium friction.

The actuation torques for raising all the FROPS are positive. For lowering the low and medium friction FROPS, the actuation torques are mainly positive, which means that the motor keeps the FROPS from falling. The actuation torques for lowering FROPS with medium friction may be negative before a specific point close to the up-locking point. This point is called the breaking point. At this point, the torque angle curve crosses the horizontal line (fig. 7). The breaking point in figure 7 is around 50° . The motor pushes the FROPS while lowering the FROPS from the up-locking point to the breaking point. After the breaking point, the motor keeps the FROPS from falling as it is being lowered.

For high friction FROPS, there is a substantial difference between the actuation torques for raising and lowering. For FROPS with high friction, the lowering actuation torque is negative, which means that the motor pushes the upper part of the FROPS downward. Figure 10 shows the results of dynamic tests of the Exmark 6 FROPS, which has high friction. For high friction FROPS, the moment of the friction force is higher than the moment of weight of the upper part of the FROPS. The results in table 2 show that the actuation torques required to lower the Snapper and Exmark 6 FROPS at representative points are negative before and after greasing, which means that those two FROPS have a high level of friction.

In addition, the static actuation torques for lowering FROPS with high friction are negative, as presented by.

Actuation torques for four models of FROPS (Snapper Pro, Gravely, Kubota, and Exmark) were measured for raising and lowering, in dynamic and static situations, before and after greasing (tables 2 and 3). Results for these four models of FROPS were measured to show how friction varies for different models of FROPS. The friction can change the actuation torques of the FROPS between 0% to 212%.

Actuation torques for seven FROPS from the same model were measured and compared to show how actuation torques are dissimilar among the same model of FROPS. Results showed that the actuation torque required to raise and lower the same FROPS changed between 0% and 145% for raising and between 6% and 212% for lowering the FROPS. This dissimilarity among the same model of FROPS may be due to differences in manufacturing (small inconsistencies in assembly and part size) as well as differences in maintenance, working conditions, friction, and age of the FROPS. There was a difference in the representative point of the same model of Exmark FROPS (tables 2 and 3). The representative angles for Exmark FROPS are -9.0 and -16.8 degrees. This difference in the same model of FROPS could be due to structural or friction differences.

The raising and lowering frictions are different for the same FROPS, as shown in tables 2 and 3. This difference could be due to changes in surface properties and the coefficient of friction in different directions. Friction was calculated using equation 3 based on TT. There could also be some error due to variations in FROPS dimensions and weight measurements that caused errors in torque calculation (TT) and consequently in friction estimation.

Dynamic Actuation Torques after Greasing

The measured actuation torque for raising and lowering two FROPS after greasing are shown in figures 6 and 9. The trend of the actuation torques for FROPS after greasing is the same as before greasing. The actuation torques are higher for raising than for lowering, but the raising and lowering curves become closer to each other and the theoretical curve (figs. 6 and 9). The measured actuation torques for raising and lowering the FROPS before and after greasing are presented in tables 2 and 3. The results showed that, in most cases, the friction force could be decreased by greasing the FROPS, but decreasing the friction increased the lowering actuation (resisting) forces and decreased the raising forces of FROPS with low and medium friction. The friction helps to hold the FROPS when lowering FROPS with low and medium friction. By decreasing the friction, the required actuation torque to hold the FROPS increases (table 2). For FROPS with high friction (Snapper and Exmark 6), the actuation torque required to lower (push down) the FROPS after greasing is lower than before greasing. To lower FROPS with high friction, the motor pushes the FROPS; by decreasing the friction, the actuation torque to lower the FROPS decreases. By greasing the FROPS, the actuation torque required to raise the FROPS decreases in most cases, but for some cases it does not change.

Static Actuation Torques

Two static torques were measured: static holding and static initiation. The static initiation torques for raising and lowering have the highest and lowest values, respectively, compared to the other treatments. The static initiation torque comprises w , fS , and i . The w , i , and fS moments were in the negative direction for raising. For lowering, i and fS were in the positive direction, which is the opposite direction of w . The difference between the theoretical torques and static initiation torques are due to i and fS .

The static initiation torques for raising and lowering a FROPS with low friction are shown in figure 5. There is a small difference between the static initiation torques for raising and lowering the FROPS. This difference is due to i and the small fS . The static initiation torques for raising and lowering a FROPS with medium friction are shown in figure 8. There is a significant difference between the static initiation torques for raising and lowering, which is due to the effects of i and fS . There is a considerable difference between the static initiation torques for raising and lowering FROPS with high friction. In addition, the static initiation torque for lowering has a negative value as the FROPS is pushed down (Khorsandi et al., 2016). The static holding torque includes fS and w . The static holding torque for a FROPS with low friction is the same for raising and lowering and is equal to w and equal to the theoretical actuation torques (fig. 5). Khorsandi et al. (2016) reported the same results for FROPS with low friction.

The static holding torques for raising and lowering a FROPS with medium friction have substantial difference (fig. 8). In addition, the measured static holding torque for each angle is not a constant value, and it can be measured in a range from $w + fS$ to $w - fS$. The resisting friction force is not a constant value, and it increases as the applied force increases from zero to the initiation of movement. Therefore, fS and consequently the measured static holding torque is not a constant value. When the FROPS stops at a certain angle and there is no movement or intention for movement, the actuation torque is equal to w . When the initiation torque is changed, before the initiation of movement, the initiation torque is equal to the combination effect of w and fS ; If the motor intends to raise the FROPS, the static holding torque (before moving) changes between w and $w + fS$. If the motor intends to lower the FROPS, the static holding torque changes between w and $w - fS$ (the maximum value of fS). The measured fS in static initiation is the maximum value of fS , which happens exactly at the moment of movement initiation. The fS direction is against the intended turning direction.

OECD Code 7 (OECD, 2017) recommends measuring FROPS actuation forces in a “static holding” condition. The results of this study showed that the measured static holding torque is not a constant value. Static holding torque changes between w and $w - fS$ for lowering and between w and $w + fS$ for raising. Most operators raise and lower the FROPS in a dynamic condition without any stops (except at the up-locking and down-locking points). Khorsandi et al. (2016) showed that there is a significant difference between static and dynamic actuation torques. Therefore, for FROPS with friction, the dynamic method is recommended to measure the actual actuation torques required for operators to raise and lower the FROPS.

Conclusion

In this study, the effect of friction on actuation torque was evaluated. The actuation torques required to raise and lower the FROPS are a function of the weight, friction, and inertial moments about the pivot point. The effect of inertial forces on the actuation torque is negligible, except around the start and stop points, which were not evaluated in this study. A theoretical actuation torque was calculated based on the weight moment, which can be measured and calculated accurately. The theoretical model was used as a criterion to calculate the effect of the friction moment on the actuation torque. Results showed that friction can have a significant effect on the actuation torque. In some cases, the friction affected the actuation torque by two times (200%) the theoretical actuation torque (or weight moment).

ROPS of the same model produced different results. The friction for several FROPS of the same model changed from 0% to 122%. This may be due to small design dissimilarities for the same model, differences in manufacturing (small inconsistencies in assembly and part size), and variations in the maintenance, working conditions, and age of the FROPS. The friction force can be decreased by greasing the FROPS, and decreasing the friction decreased the raising actuation torque of all FROPS and increased the lowering actuation torque for FROPS with high friction. For the FROPS with high friction, the friction torque was higher than the theoretical torque (weight moment), i.e., the friction was higher than 100%. For the FROPS with friction lower than 100%, the lowering actuation torque increased by decreasing the friction.

OECD Code 7 recommends measuring the actuation torque with the FROPS stopped at specific angles, which is called the static holding actuation torque. The results of this study showed that the static holding actuation torque is not constant and depends on the measurement method. A dynamic method is recommended for measuring FROPS actuation torques. The dynamic actuation torque was measured while raising or lowering the FROPS without stopping, which is the way that operators raise or lower FROPS.

The actuation torque can be estimated by knowing the theoretical actuation torque (weight moment) and friction. The results of this study can be used to improve the understanding of the actuation torques required to raise and lower FROPS and design fold-assist mechanisms.

Nomenclature

All moments are around the pivot point (fig. 1).

CG	center of gravity
f	moment of friction
fK	moment of kinetic friction
fS	moment of static friction
F	friction

FAT	theoretical actuation force
FROPS	foldable rollover protective structure
i	moment of inertia
I	inertial force
L1	fork length
L2	distance from CG of upper part to the pivot point
ROPS	rollover protective structure
TT	theoretical actuation torque
TE	measured actuation torque
T	actuation torque
w	moment of weight of upper part of FROPS
W	weight of upper part of FROPS

References

- Ayers PD, Khorsandi F, John Y, & Whitaker G (2016). Development and evaluation of a computer-based ROPS design program. *J. Agric. Saf. Health*, 22(4), 247–260. 10.13031/jash.22.11745 [PubMed: 29140625]
- Ayers PD, Khorsandi F, Wang X, & Araujo G (2018). ROPS designs to protect operators during agricultural tractor rollovers. *J. Terramech*, 75, 49–55. 10.1016/j.jterra.2017.05.003
- BLS. (2016). Census of fatal occupational injuries summary, 2015 Washington, DC: Bureau of Labor Statistics Retrieved from <https://www.bls.gov/news.release/cfoi.nr0.htm>
- Froula GT, Brummitt MR, & Gilliam DG (2016). The EZ-Lift: A mechanical lift-assist for rollover protection structures (B. Sc. undergraduate final design project). Knoxville, TN: University of Tennessee.
- Hoy RM (2009). Farm tractor rollover protection: Why simply getting rollover protective structures installed on all tractors is not sufficient. *J. Agric. Saf. Health*, 15(1), 3–4. [PubMed: 19266880]
- ISO. (2009). ISO 21299:2009: Powered ride-on turf care equipment - Rollover protective structures (ROPS) - Test procedures and acceptance criteria. Geneva, Switzerland: ISO.
- Khorsandi F (2017). Study on agricultural tractor operator safety in rollover accidents. PhD diss. Knoxville, TN: University of Tennessee, Department of Biosystems Engineering and Soil Science.
- Khorsandi F, Ayers PD, Jackson DL, & Wilkerson J (2016). The effect of speed on foldable ROPS actuation forces. *J. Agric. Saf. Health*, 22(4), 285–298. 10.13031/jash.22.11752 [PubMed: 29140626]
- Martin L (2017). Evaluation of foldable tractor rollover protective structures (ROPS) clearance. Pursuit - J. Undergrad. Research at the University of Tennessee, 8(1), article 9. Retrieved from <http://trace.tennessee.edu/pursuit/vol8/iss1/9>
- Murphy DJ, & Buckmaster DR (2014). Rollover protection for farm tractor operators. University Park, PA: Penn State Extension Retrieved from <http://extension.psu.edu/business/ag-safety/vehicles-and-machinery/tractor-safety/e42>
- Myers J (2009). Preventing death and injury in tractor overturns with rollover protective structures NIOSH Science Blog. Atlanta, GA: Centers for Disease Control and Prevention Retrieved from <https://blogs.cdc.gov/niosh-science-blog/2009/01/05/rops/>

- Myers M (2015). Folding ROPS or automatically deployable ROPS? *J. Agric. Saf. Health*, 21(4), 201–204. 10.13031/jash.21.11446 [PubMed: 26710577]
- NIOSH. (2018). Agricultural safety. Washington, DC: National Institute for Occupational Safety and Health Retrieved from <https://www.cdc.gov/niosh/topics/aginjury/>
- OECD. (2017). Code 7: OECD standard code for the official testing of rear-mounted rollover protective structure on narrow-track agricultural and forestry tractors. Paris, France: Organization for Economic Cooperation and Development Retrieved from <http://www.oecd.org/agriculture/code/40221188.pdf>
- OSHA. (2005). OSHA 1928.51: Rollover protective structures (ROPS) for tractors used in agricultural operations. Washington, DC: OSHA.
- OSHA. (2013). Dangers of rollovers of riding mowers. Washington, DC: OSHA Retrieved from https://www.osha.gov/dsg/riding_mowers
- Pessina D, Facchinetti D, & Giordano DM (2016). Narrow-track agricultural tractors: A survey on the load of the hand-operated foldable rollbar. *J. Agric. Saf. Health*, 22(4), 275–284. 10.13031/jash.22.11709 [PubMed: 29140624]
- Spielholz P, Sjostrom T, Clark RE, & Adams DA (2006). A survey of tractors and rollover protective structures in Washington State. *J. Agric. Saf. Health*, 12(4), 325–333. 10.13031/2013.22012 [PubMed: 17131952]

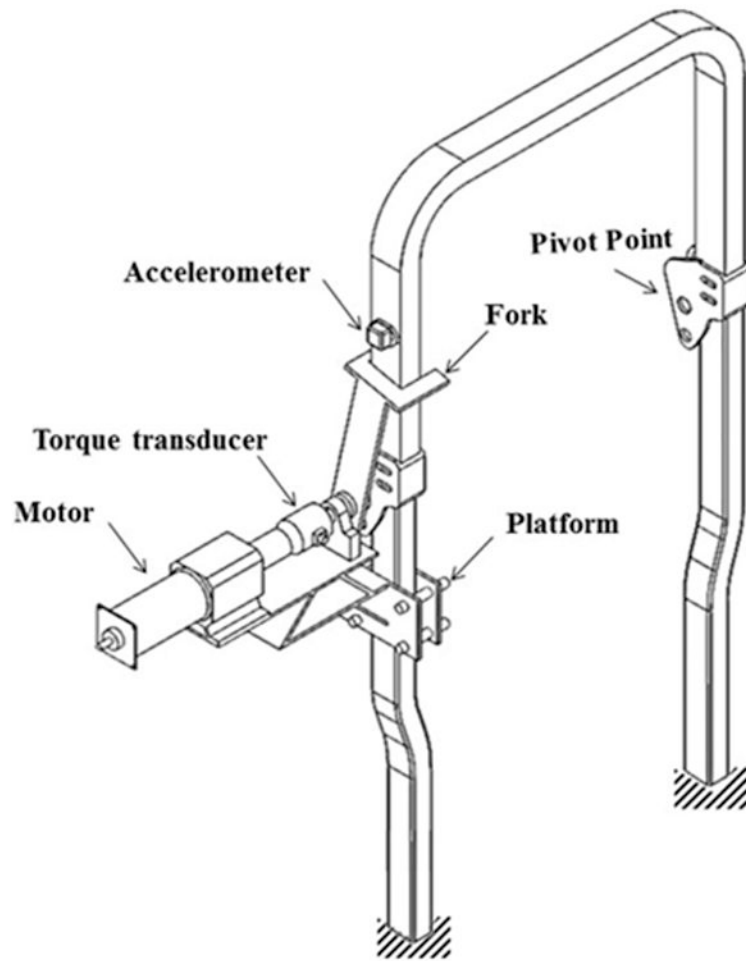

Figure 1.
Actuation torque measurement with constant speed.

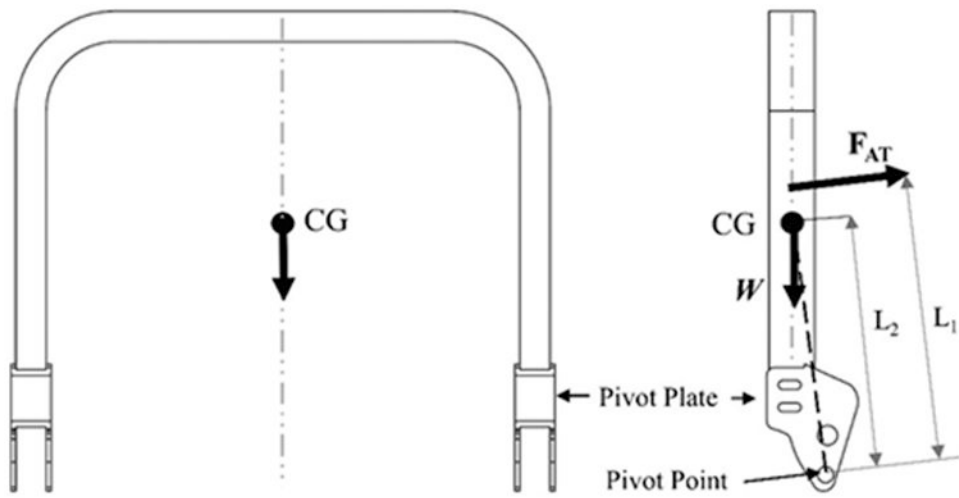

Figure 2. Center of gravity (CG) location (L_2) and actuation torque arm (L_1) in front and side views of the upper part of a FROPS.

Author Manuscript

Author Manuscript

Author Manuscript

Author Manuscript

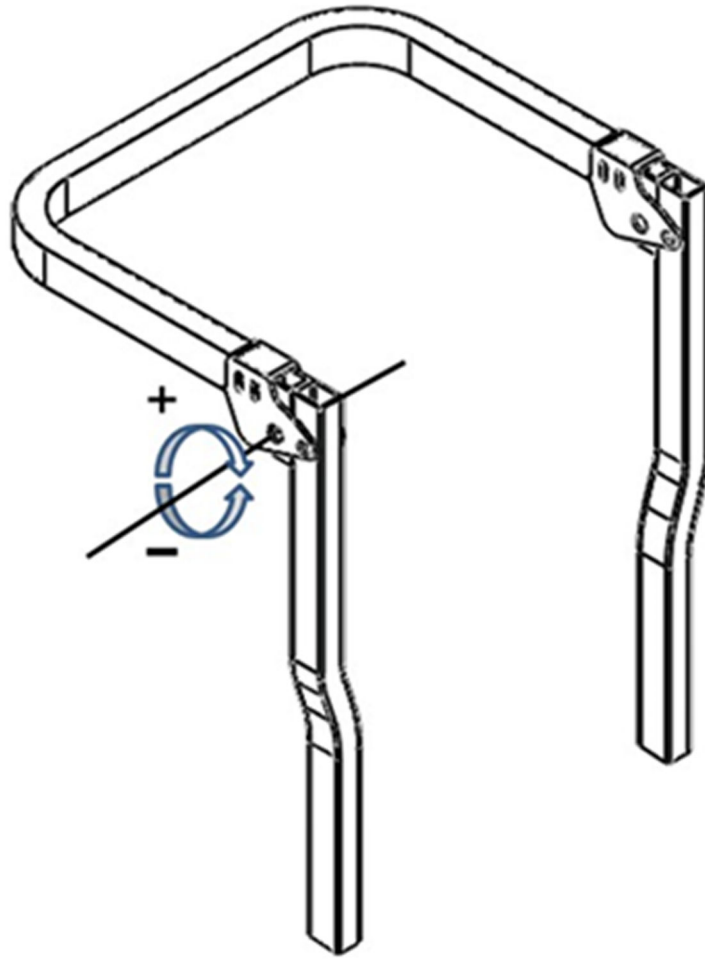

Figure 3.
Actuation torque directions.

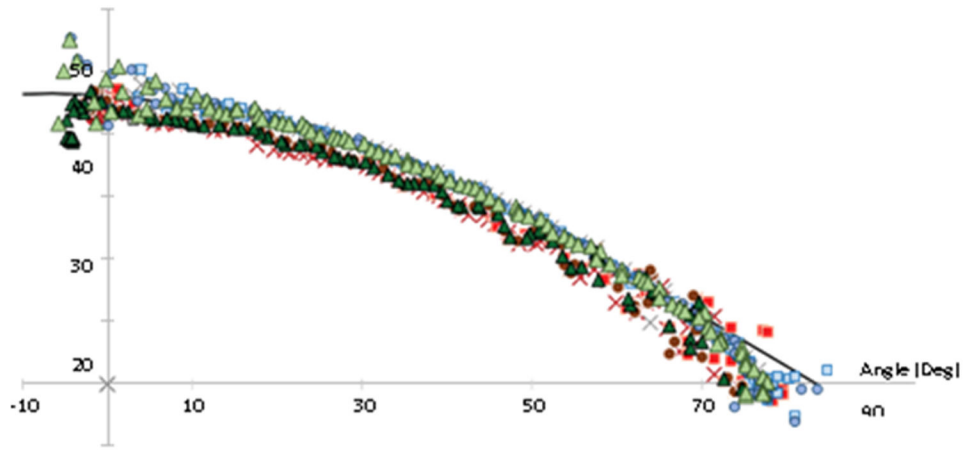

Figure 4. Actuation torques for four replications of raising and lowering the Gravely FROPS and theoretical torque.

Author Manuscript

Author Manuscript

Author Manuscript

Author Manuscript

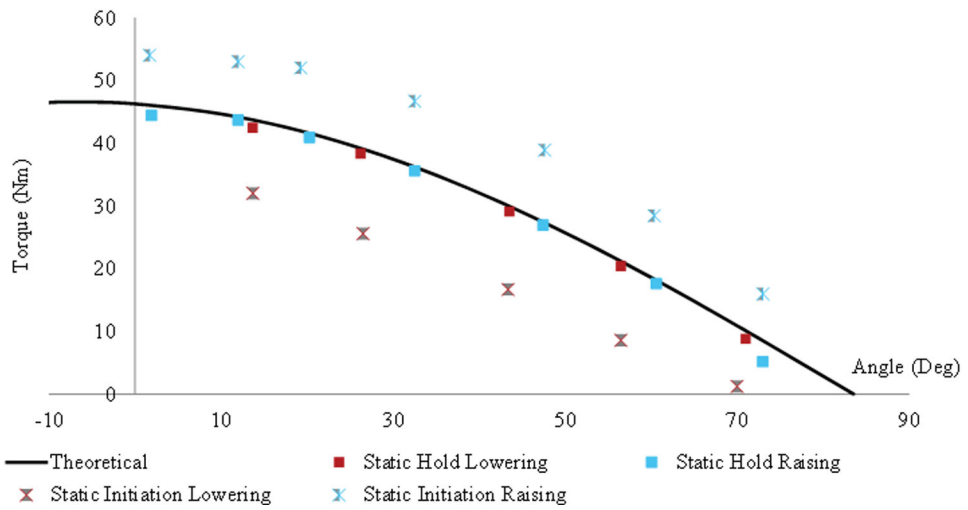

Figure 5. Static holding torque and static transient torque for raising and lowering the Gravelly FROPS.

Author Manuscript

Author Manuscript

Author Manuscript

Author Manuscript

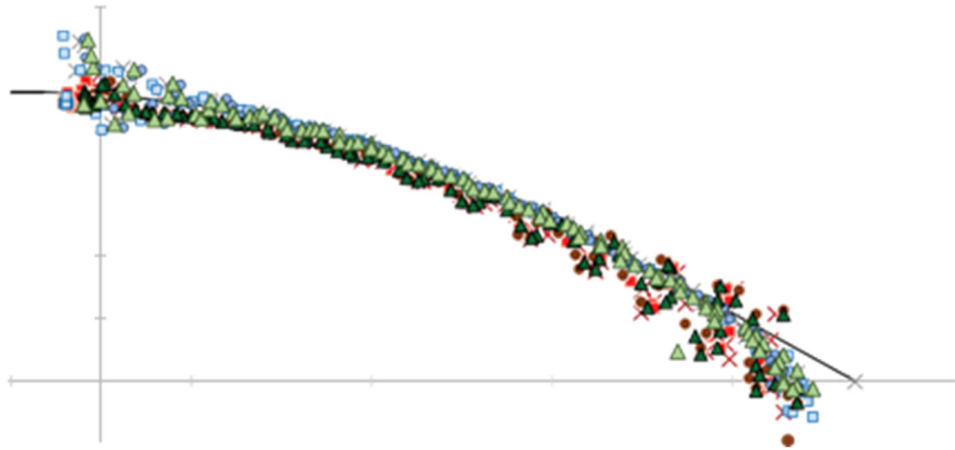

Figure 6. Actuation torques for four replications of raising and lowering the Gravely FROPS after greasing and theoretical torque.

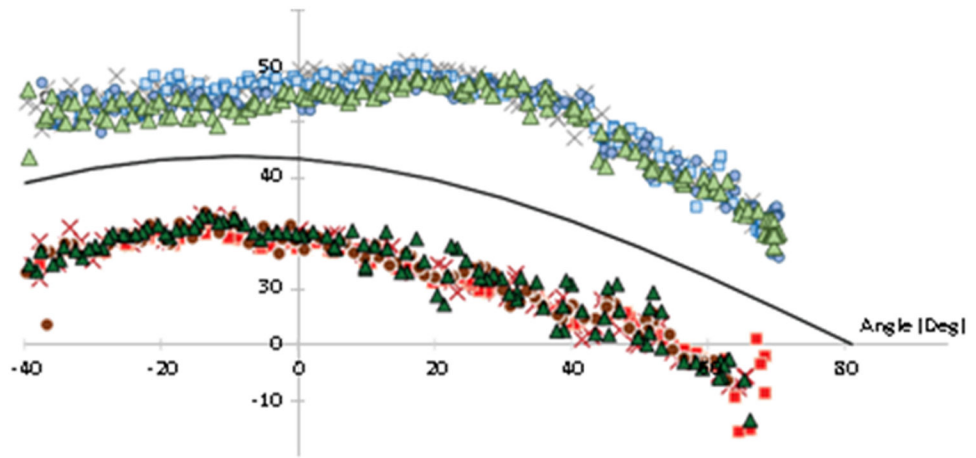

Figure 7. Actuation torques for four replications of raising and lowering the Exmark 5 FROPS and theoretical torque.

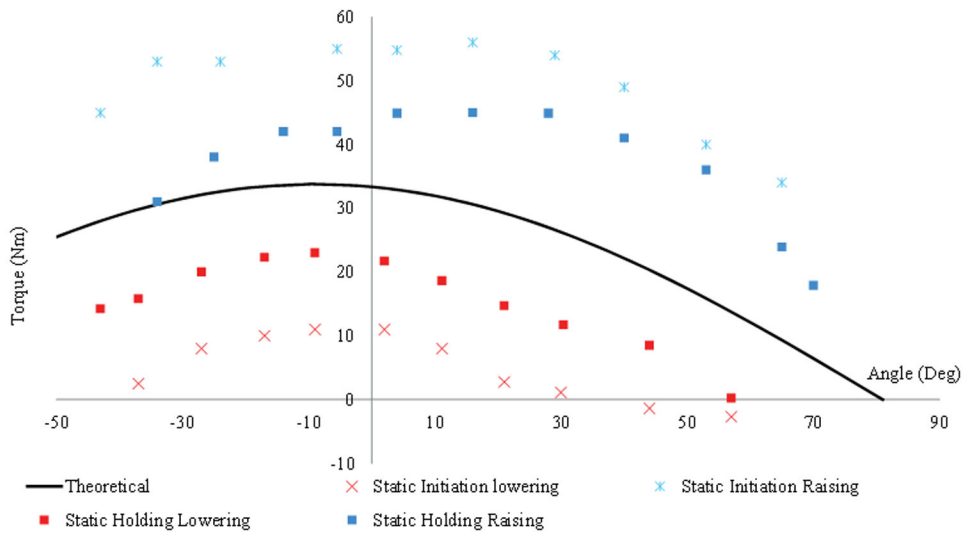

Figure 8. Static holding and static transient torques for raising and lowering the Exmark 5 FROPS.

Author Manuscript

Author Manuscript

Author Manuscript

Author Manuscript

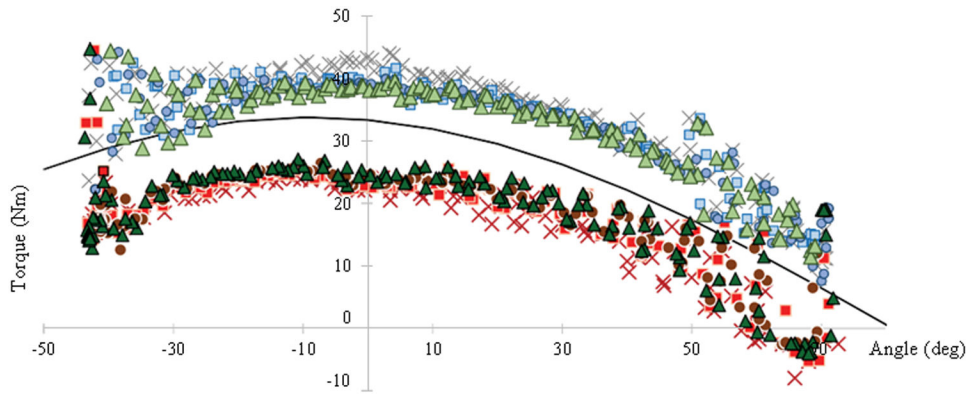

Figure 9. Actuation torques for four replications of raising and lowering the Exmark 5 FROPS after greasing and theoretical torque.

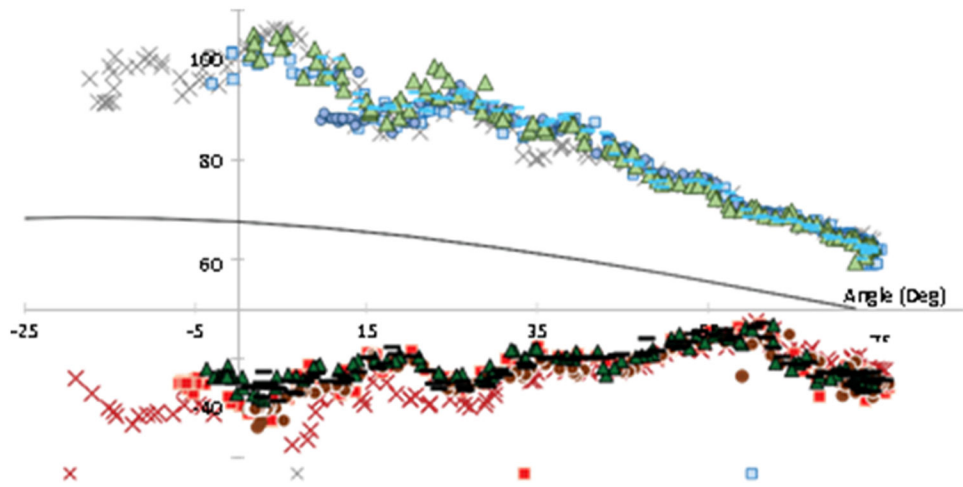

Figure 10. Actuation torques for five replications of raising and lowering the Exmark 6 FROPS and theoretical torque.

Table 1.

Test, vehicle, and FROPS information.

Vehicle Manufacturer and Model	Series	FROPS Label	ROPS Standard	Pinned Angels	
				Up Locking	Down Locking
Snapper Pro S200xt	S-series	-	OSHA 1928.51	90.0°	-31.0°
Gravely Pro-Master	PM 3084	FEMCO model 301113835	ISO 21299	89.6°	-87.9°
Kubota	B7510	SFB-F24	OSHA 1928.51	80°	-80°
Exmark Lazer Z (1)	LZ740KC604	Exmark Mfg. Co., Inc.	OSHA 1928.51	77.0°	-40.8°
Exmark Lazer Z (2)	S-series	Exmark Mfg. Co., Inc.	OSHA 1928.51	82.4°	-34.1°
Exmark Lazer Z (3)	S-series	Exmark Mfg. Co., Inc.	OSHA 1928.51	77.7°	-40°
Exmark Lazer Z (4)	S-series	Exmark Mfg. Co., Inc.	OSHA 1928.51	88.1°	-52.2°
Exmark Lazer Z (5)	S-series	Exmark Mfg. Co., Inc.	OSHA 1928.51	80.3°	-38.4°
Exmark Lazer Z (6)	S-series	Exmark Mfg. Co., Inc.	OSHA 1928.51	73.9°	-55.2°
Exmark Lazer Z (7)	S-series	Exmark Mfg. Co., Inc.	OSHA 1928.51	79.8°	-40°

Table 2.

Dynamic actuation torques for lowering FROPS in multiple replications.

FROPS	Representative Torque (Nm), Experimental		Representative Torque with Greasing (Nm), Experimental		Representative Point, Theoretical	
	Angle (deg.)	Torque (Nm)	Mean \pm s	Friction	Mean \pm s	Friction
Snapper	-30.5 \pm 13.2	-197%	-15.0 \pm 2.4	-148%	-11.8	31.4
Gravely	39.0 \pm 0.2	-7%	39.6 \pm 0.2	-5%	20.0	41.8
Kubota	28.7 \pm 2.7	-44%	41.2 \pm 4.8	-19%	-19.3	50.9
Exmark 1	30.2 \pm 0.1	-11%	NA	NA	-9.0	33.8
Exmark 2	31.5 \pm 0.2	-7%	NA	NA	-9.0	33.8
Exmark 3	31.7 \pm 0.5	-6%	32.7 \pm 0.3	-3%	-9.0	33.8
Exmark 4	17.7 \pm 3.0	-43%	22.3 \pm 2.1	-29%	-16.8	31.3
Exmark 5	20.8 \pm 0.5	-34%	24.5 \pm 0.8	-22%	-16.8	31.3
Exmark 6	-36.3 \pm 7.0	-212%	-2.9 \pm 11.8	-109%	10.0	32.4
Exmark 7	21.2 \pm 0.5	-37%	28.3 \pm 1.4	-16%	-9.0	33.8

Table 3.

Actuation torques for raising FROPS in multiple replications.

FROPS	Representative Torque (Nm), Experimental		Representative Torque with Greasing (Nm), Experimental		Representative Point, Theoretical	
	Angle (deg.)	Torque (Nm)	Mean \pm s	Friction	Mean \pm s	Friction
Snapper	68.6 \pm 2.8	119%	68.9 \pm 3.5	119%	-11.8	31.4
Gravelly	42.4 \pm 0.1	1%	42.0 \pm 0.4	0.5%	20.0	41.8
Kubota	87.6 \pm 0.3	72%	78.8 \pm 2.6	55%	-19.3	50.9
Exmark 1	33.8 \pm 0.2	0%	NA	NA	-9.0	33.8
Exmark 2	35.1 \pm 0.5	4%	NA	NA	-9.0	33.8
Exmark 3	34.6 \pm 0.3	2%	34.0 \pm 0.8	1%	-9.0	33.8
Exmark 4	47.9 \pm 1.9	53%	34.7 \pm 1.4	11%	-16.8	31.3
Exmark 5	44.3 \pm 1.9	42%	38.2 \pm 0.8	22%	-16.8	31.3
Exmark 6	94 \pm 2.8	145%	52.1 \pm 2.6	34%	10.0	32.4
Exmark 7	42.1 \pm 2	25%	37.4 \pm 1.6	11%	-9.0	33.8