

UC Berkeley

SEMM Reports Series

Title

Seismic Response of Lightweight Concrete Panels with Friction-Based Energy Dissipators

Permalink

<https://escholarship.org/uc/item/17c287t5>

Authors

Sasani, Mehrdad

Popov, Egor

Blondet, J.

et al.

Publication Date

1997-12-01

**SEISMIC RESPONSE OF LIGHTWEIGHT CONCRETE PANELS
WITH FRICTION-BASED ENERGY DISSIPATORS**

BY

**MEHRDAD SASANI
EGOR P. POPOV
MARCIAL BLONDET
LEV STEPANOV**

EARTHQUAKE ENG. RES. CTR.

Univ. of Calif. - 453 R.F.S.

1301 So. 46th St.

Richmond, CA 94804-4698 USA

(510) 231-9403

REPORT TO

NABIH YOUSSEF & ASSOCIATES

**Report No. UCB/SEMM-97/17
Structural Engineering, Mechanics and Materials
Department of Civil & Environmental Engineering
University of California at Berkeley**

December 1997

Contents

1 Introduction	1
2 Test Setup	4
3 Precast Panels	8
4 Energy Dissipators	11
5 Anchorage System	16
6 Instrumentation & Data Acquisition	20
7 Testing Program	23
7.1 Selection of Input Signals	23
7.2 Phase A: Panel with Hilti Kwik Concrete Anchorage	25
7.3 Phase B: Panel with Hilti Hit Hy-150 Adhesive Anchor System	40
8 Concluding Remarks	54
References	55
Acknowledgements	55
Appendix A: Supplementary Tests	
Appendix B: Test Results	

1 INTRODUCTION

This report summarizes the results of a testing program on an energy dissipation system proposed as part of the seismic retrofit of the Rivera Library of the University of California at Riverside (UCR). Nabih Youssef & Associates designed the retrofit system. The tests were carried out in the Structural Testing Laboratory of the Department of Civil and Environmental Engineering of the University of California at Berkeley (UCB). The Principal Investigator was Professor Egor P. Popov.

The UCR Rivera Library is a 4-story building clad with precast lightweight concrete panels (Fig. 1.1). As part of the seismic retrofit program of the library, it is proposed that the exterior panels be connected to the structure with friction-based energy dissipating. These dissipators, also known as slotted bolted connections, have shown in the laboratory excellent energy dissipation characteristics [1]. Figure 1.2 presents drawings prepared by Nabih Youssef and Associates showing the main features of the proposed system. Each precast panel will be connected to the bottom floor with bolted steel connectors. Three energy dissipators will be bolted near the top of each panel and to the beam of the corresponding top floor. It is expected that the relative motion between adjacent floors due to seismic excitations will activate the dissipators.

The main objective of this testing program was to investigate the earthquake performance characteristics of the proposed energy dissipation system. The project consisted of subjecting a full-scale model of the panels and energy dissipators to dynamic excitations representative of those that would be expected in the field.

The test program was performed in two phases. The first phase involved using Hilti Kwik Concrete Anchor Bolts to connect the energy dissipating devices at the top and also the fixed supports at the bottom to the panel. Although the energy dissipating devices showed acceptable behavior with stable hysteretic loops, using this type of anchorage led to excessive rocking of the panel which in turn reduced energy dissipating capacity of the system. Therefore a new type of anchorage, Hilti Hit HY-150 Adhesive Anchor System, was used. The behavior of the system using the latter type of anchorage was considered to be satisfactory.

This report briefly describes the testing program and the main results obtained.



Figure 1.1. Pictures of the Rivera Library of the University of California at Riverside (UCR)

2 TEST SETUP

The reaction frame, the lightweight concrete panel, the energy dissipators, the fixed bottom supports, and the dynamic loading system are shown in Fig. 2.1. Figure 2.2 includes a photograph of the test setup and a specimen after one of the dynamic tests.

The in-plane response of concrete panels was studied in this project and the three-dimensional response of panels needs further investigations. The test specimens were full-scale models of the proposed retrofit system.

Since the energy dissipating system was designed to accommodate relative vertical displacement between the panel and the structural system without transferring forces in between, the top and bottom beams were not considered in the model. The bottom supports of the panel were bolted to a steel plate, which in turn was bolted to the bottom beam of the reaction frame.

A servohydraulic dynamic actuator applied the simulated seismic motions to the system. The actuator was connected to a steel loading carriage, which represented the top beam of the building (Fig. 2.3-a). The carriage was restricted to move only horizontally, parallel to the panel. This was achieved by installing two steel shafts at each end of the carriage, which ran through low friction linear bearings (Fig. 2.3-b). The loading thus provided significant excitation to the panel-dissipation system only along its main horizontal relative motion direction.

The dynamic actuator was under displacement control. The actuator movements simulated relative horizontal motions between the top and bottom beams of the story under consideration. The displacement command signals were selected to be representative of the response of the retrofitted system under earthquake excitations.

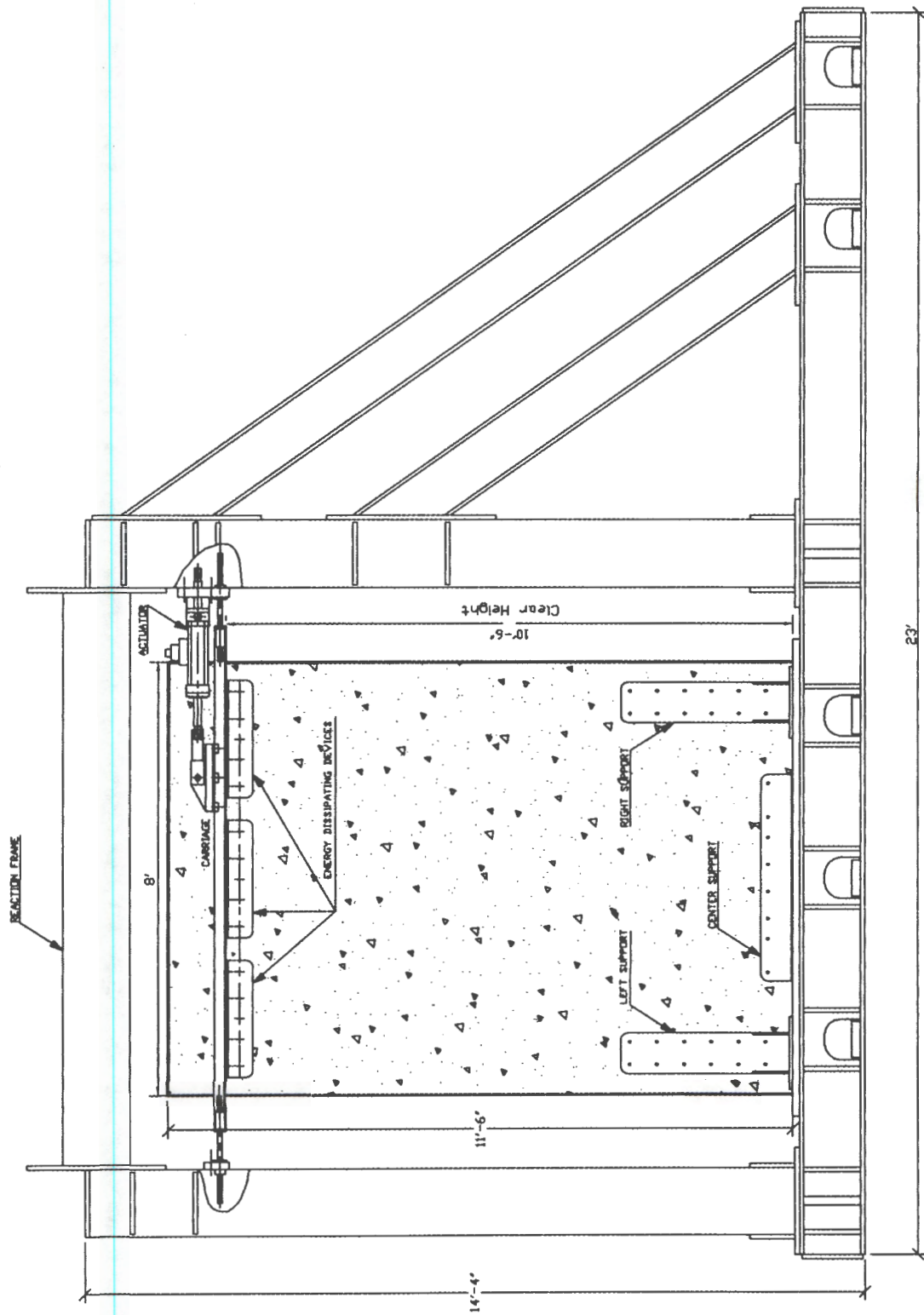

Figure 2.1. The test setup

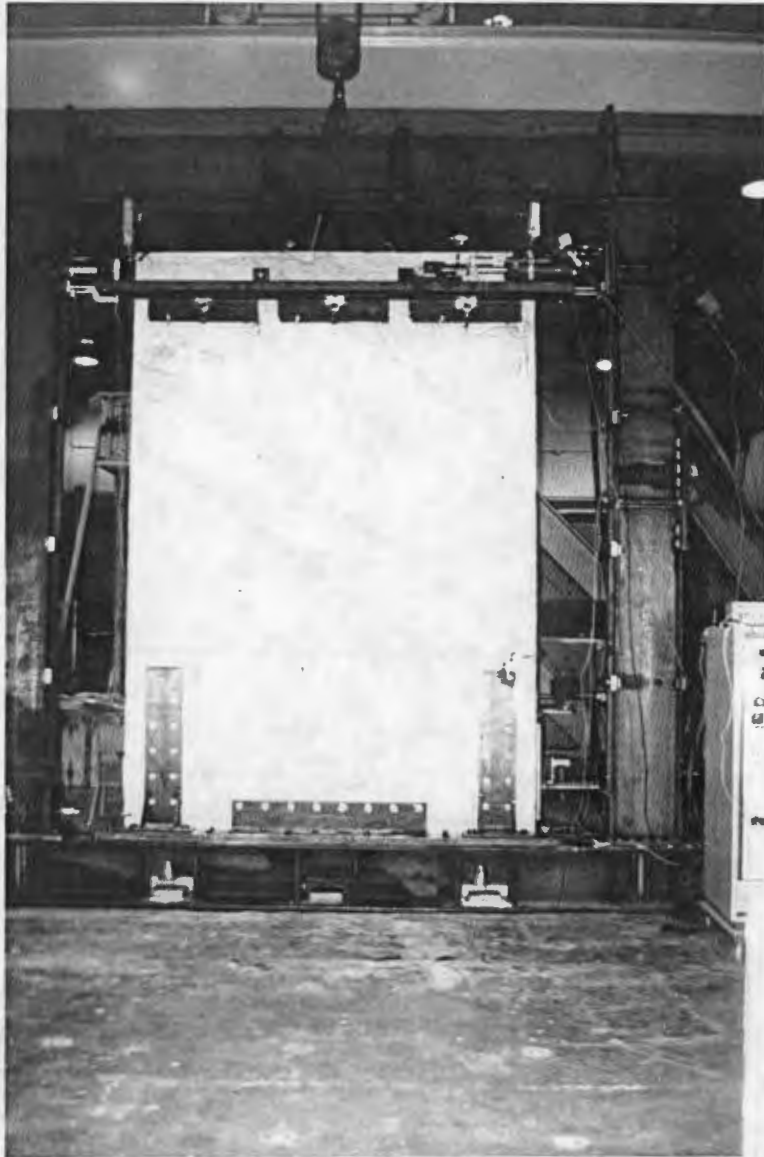
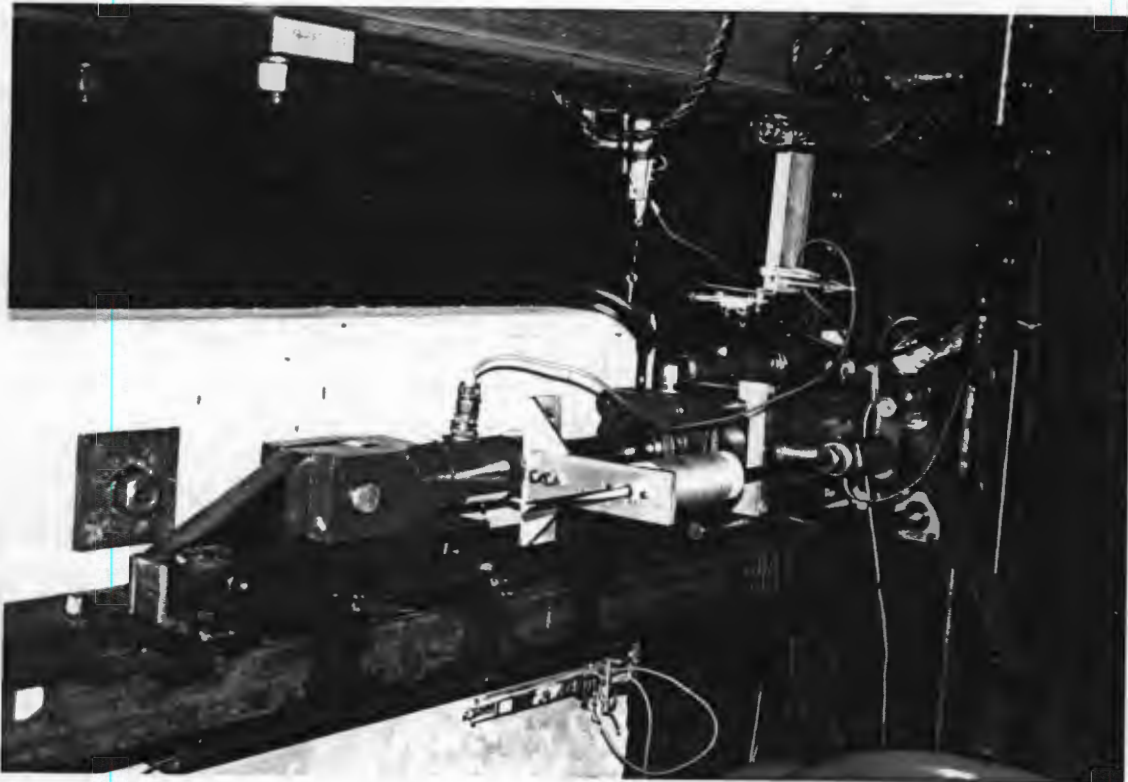

Figure 2.2. The test setup; the specimen is shown after one of the dynamic tests



(a)



(b)

Figure 2.3. (a) Dynamic actuator, (b) Low friction linear bearings

3 PRECAST PANELS

The lightweight concrete precast panels existing in the Rivera Library are about 13 ft high and 8 ft wide. They have a cross section with thickness varying linearly from 4" at the edges to 6 1/2" at the center. The test specimens were 11.5 ft high and 8 ft wide, with a rectangular cross section 5" thick. Figure 3.1 shows the cross section and reinforcement of existing panels and test specimens.

For simplicity, a rectangular section of similar area was used in the test specimens. In order to model the shear strength of the library panels, the test specimens were fabricated with a cross section area of 480 in², only 5% smaller than that of the existing panels (504 in²). It was estimated that the panels would have acceptable seismic behavior without significant cracking when subjected to dynamic lateral loading of up to 18 kips.

For fabrication and installation convenience the test specimens were built shorter than the existing panels (11.5 ft versus 13 ft). In the proposed retrofit system, the energy dissipators would be placed under the top beam, with a clear height to the base of the panels of 10.5 ft. The loading carriage was also located at a height of 10.5 ft with respect to the base of the model to model accurately the loading pattern of the prototype panel. Figure 3.2 shows the formwork and the panel reinforcement. Note the two lifting fixtures at the top of the panel (foreground of photo).

The panels were made of lightweight concrete with a compressive strength f_c of 4 ksi. Standard cylindrical concrete specimens were made during casting, and were tested in compression. The concrete mix design and the material test results are given in Appendix A-1.

The bottom supports of the panels were designed to provide a rigid connection between the panels and the bottom beam of the structure. The details of these connections are shown in Fig. 3.3. In the actual building, the supports will be attached to the panels and the concrete structure using special anchor bolts. For the experimental study, these bolts were used in the connection between supports and panel; the connection between supports and the bottom beam of the reaction frame was bolted using regular steel bolts via a connection steel plate.

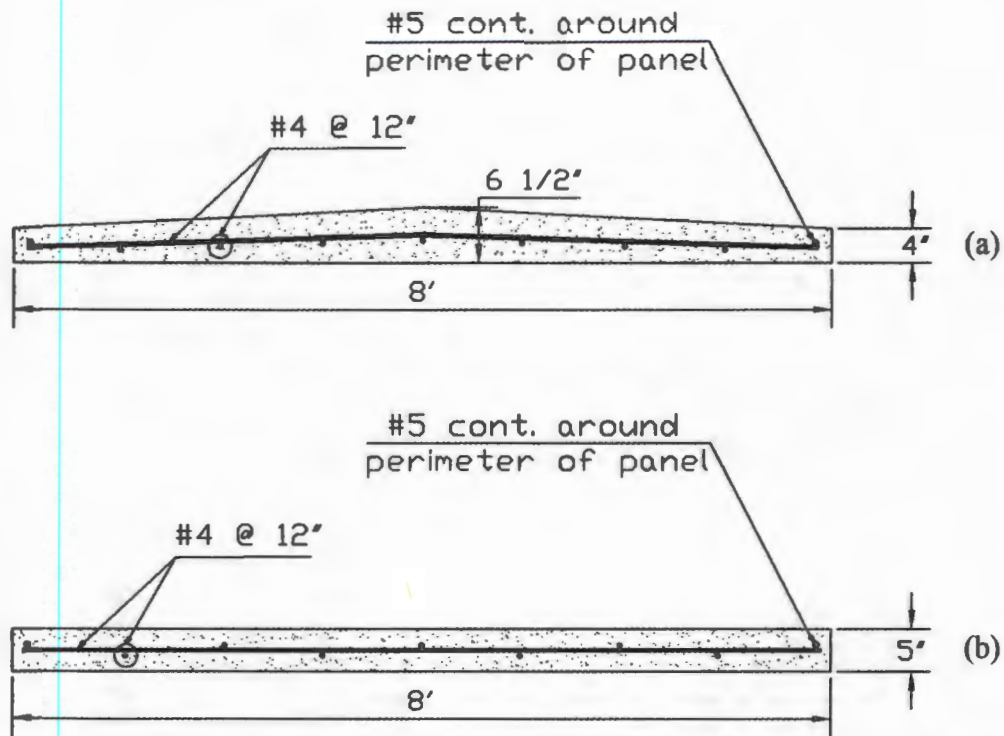

Figure 3.1. Cross-sections and reinforcement of (a) existing panel, and (b) test specimen



Figure 3.2. Panel formwork and reinforcement

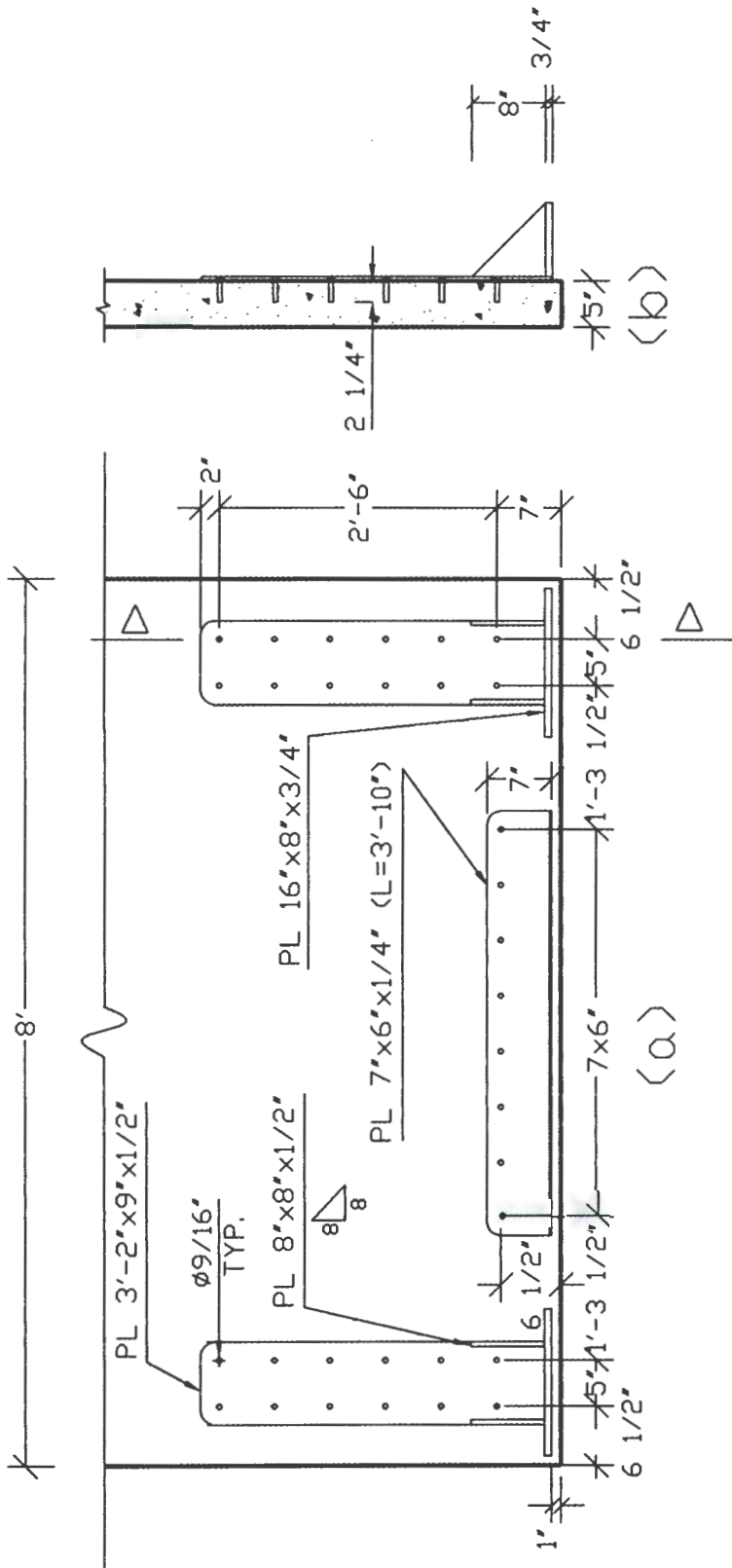

Figure 3.3. Bottom supports: (a) front view, (b) vertical section

4 ENERGY DISSIPATORS

The energy dissipators proposed for the retrofit of the Rivera Library are friction devices activated by the relative motion of two steel elements bolted together. A slotted hole along one of the pieces makes possible their relative motion. The bolts joining the two components are tightened to compress the pieces against each other. The tension in the bolts is controlled with a torque wrench so that slippage initiates at a predetermined level of force. The system is therefore very rigid if the applied forces are below the slip load. Once relative motion occurs, most of the input energy is dissipated through friction developed in the surfaces undergoing relative motion. The performance of these connectors depends significantly on the materials selected for the friction surfaces [1].

The energy dissipator studied in this project consisted of a steel tube 26" long with a 4"x3" rectangular cross section bolted to the panel (Fig. 4.1) and a 6"x4" steel angle of the same length bolted to the loading carriage (top beam in the building, Fig. 4.2). The tube had the horizontal slot required to achieve unidirectional relative motion between tube and angle. The maximum relative displacement allowed by the slot was $\pm 2"$. Access holes were provided for easy installation of the bolts and washers.

Figure 4.3 shows a cross section of an energy dissipator. The tube and the angle were connected by a 3/4" A325 steel bolt. The bolt had two brass washers type UNS 260 located in either side of the outside wall of the tube. Energy dissipation was achieved through friction between the brass washers and the two contact surfaces of the tube wall due to horizontal relative motion of the angle and the tube.

Belleville washers used in the assembly acted as springs to maintain a constant tension in the bolts. The steel angle had a vertical slot to allow for a $\pm 1"$ vertical relative motion between tube and angle. Teflon washers 1/8" thick were provided to minimize friction in the event of vertical relative motion.

Each dissipator was designed to start sliding at a force of about 6 kips. Assuming that the forces developed in the connectors after sliding would not be larger than those required to initiate sliding, the total load imposed on the panel would be about 18 kips (3 connectors per panel). The panels were estimated to have acceptable behavior at that loading level.

Figure 4.4-a shows the slotted steel tube mounted on the panel. Notice the access slots. An assembled dissipator is shown in Fig. 4.4-b. A displacement transducer is also shown.

A number of preliminary tests, described in Appendix A, were performed to characterize and calibrate the bolt system. First, the mechanical properties of the Belleville washers were studied by means of compression tests (Section A-2). The relation between the applied torque to tighten the bolt and the resulting bolt tension was also investigated (Section A-3). Finally, the friction coefficient between the brass washers and the steel sections under monotonic load was estimated experimentally (Section A-4).

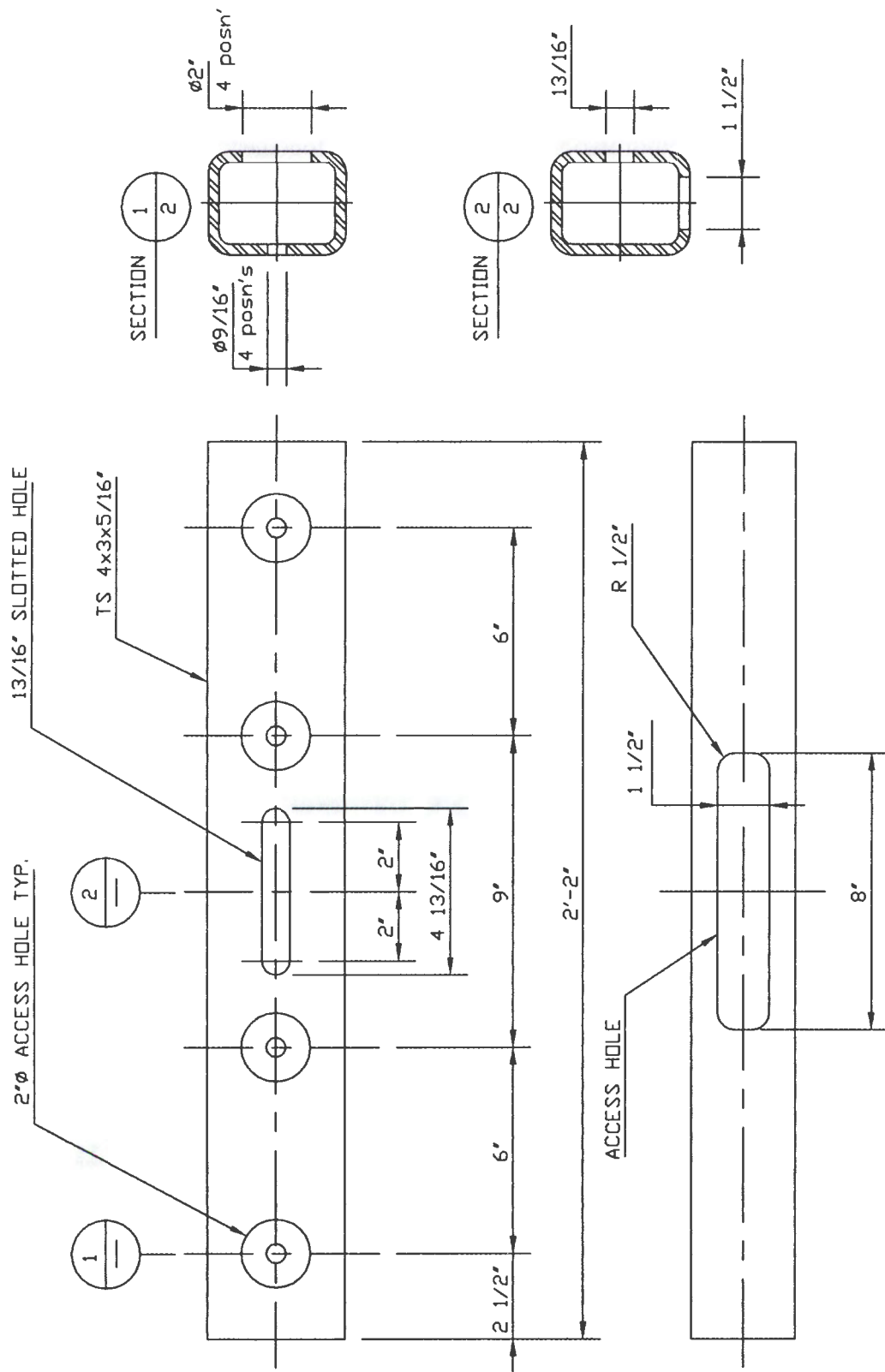

Figure 4.1. Steel tube details

4 ENERGY DISSIPATORS

The energy dissipators proposed for the retrofit of the Rivera Library are friction devices activated by the relative motion of two steel elements bolted together. A slotted hole along one of the pieces makes possible their relative motion. The bolts joining the two components are tightened to compress the pieces against each other. The tension in the bolts is controlled with a torque wrench so that slippage initiates at a predetermined level of force. The system is therefore very rigid if the applied forces are below the slip load. Once relative motion occurs, most of the input energy is dissipated through friction developed in the surfaces undergoing relative motion. The performance of these connectors depends significantly on the materials selected for the friction surfaces [1].

The energy dissipator studied in this project consisted of a steel tube 26" long with a 4"x3" rectangular cross section bolted to the panel (Fig. 4.1) and a 6"x4" steel angle of the same length bolted to the loading carriage (top beam in the building, Fig. 4.2). The tube had the horizontal slot required to achieve unidirectional relative motion between tube and angle. The maximum relative displacement allowed by the slot was $\pm 2"$. Access holes were provided for easy installation of the bolts and washers.

Figure 4.3 shows a cross section of an energy dissipator. The tube and the angle were connected by a 3/4" A325 steel bolt. The bolt had two brass washers type UNS 260 located in either side of the outside wall of the tube. Energy dissipation was achieved through friction between the brass washers and the two contact surfaces of the tube wall due to horizontal relative motion of the angle and the tube.

Belleville washers used in the assembly acted as springs to maintain a constant tension in the bolts. The steel angle had a vertical slot to allow for a $\pm 1"$ vertical relative motion between tube and angle. Teflon washers 1/8" thick were provided to minimize friction in the event of vertical relative motion.

Each dissipator was designed to start sliding at a force of about 6 kips. Assuming that the forces developed in the connectors after sliding would not be larger than those required to initiate sliding, the total load imposed on the panel would be about 18 kips (3 connectors per panel). The panels were estimated to have acceptable behavior at that loading level.

Figure 4.4-a shows the slotted steel tube mounted on the panel. Notice the access slots. An assembled dissipator is shown in Fig. 4.4-b. A displacement transducer is also shown.

A number of preliminary tests, described in Appendix A, were performed to characterize and calibrate the bolt system. First, the mechanical properties of the Belleville washers were studied by means of compression tests (Section A-2). The relation between the applied torque to tighten the bolt and the resulting bolt tension was also investigated (Section A-3). Finally, the friction coefficient between the brass washers and the steel sections under monotonic load was estimated experimentally (Section A-4).

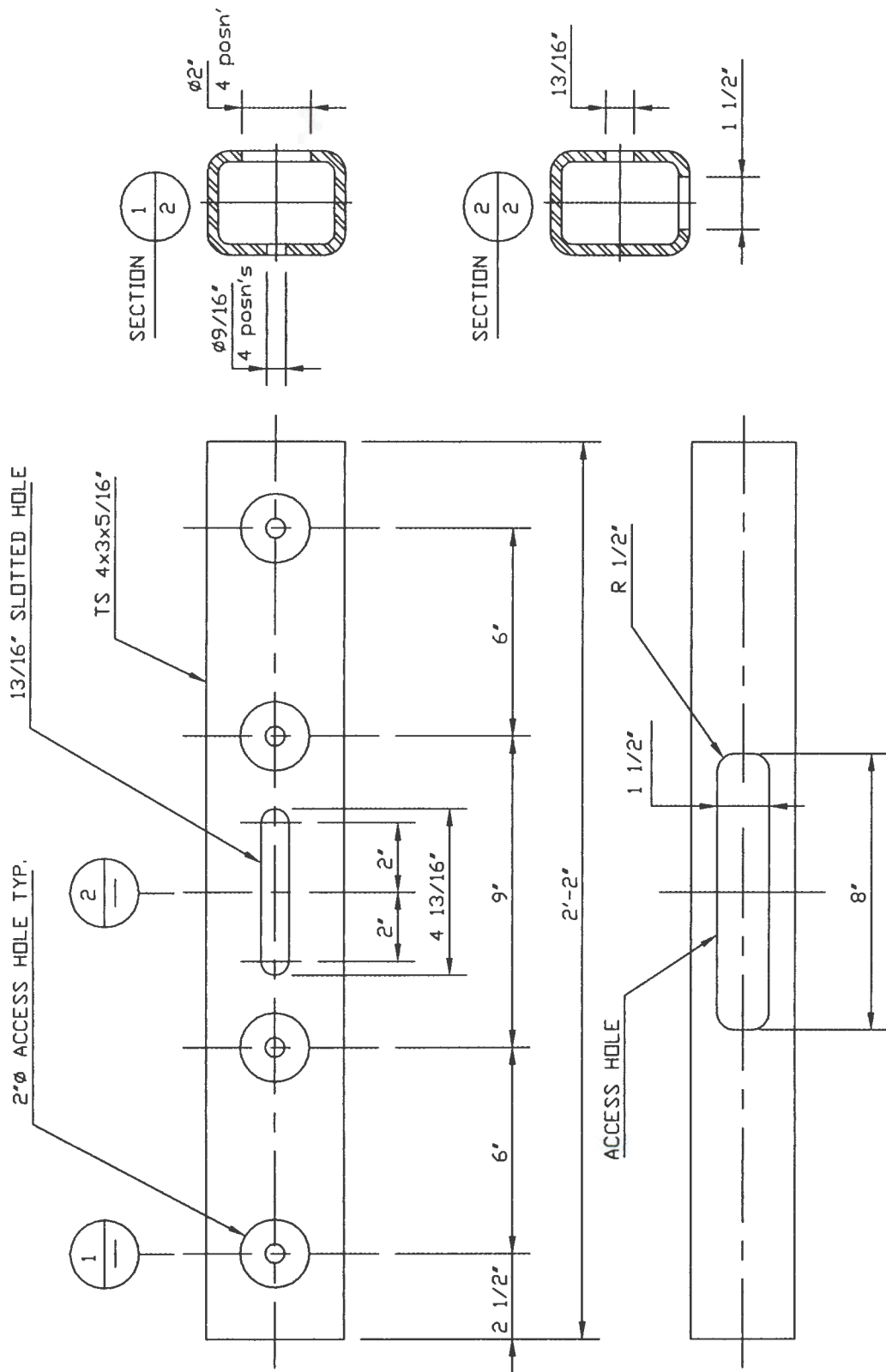

Figure 4.1. Steel tube details

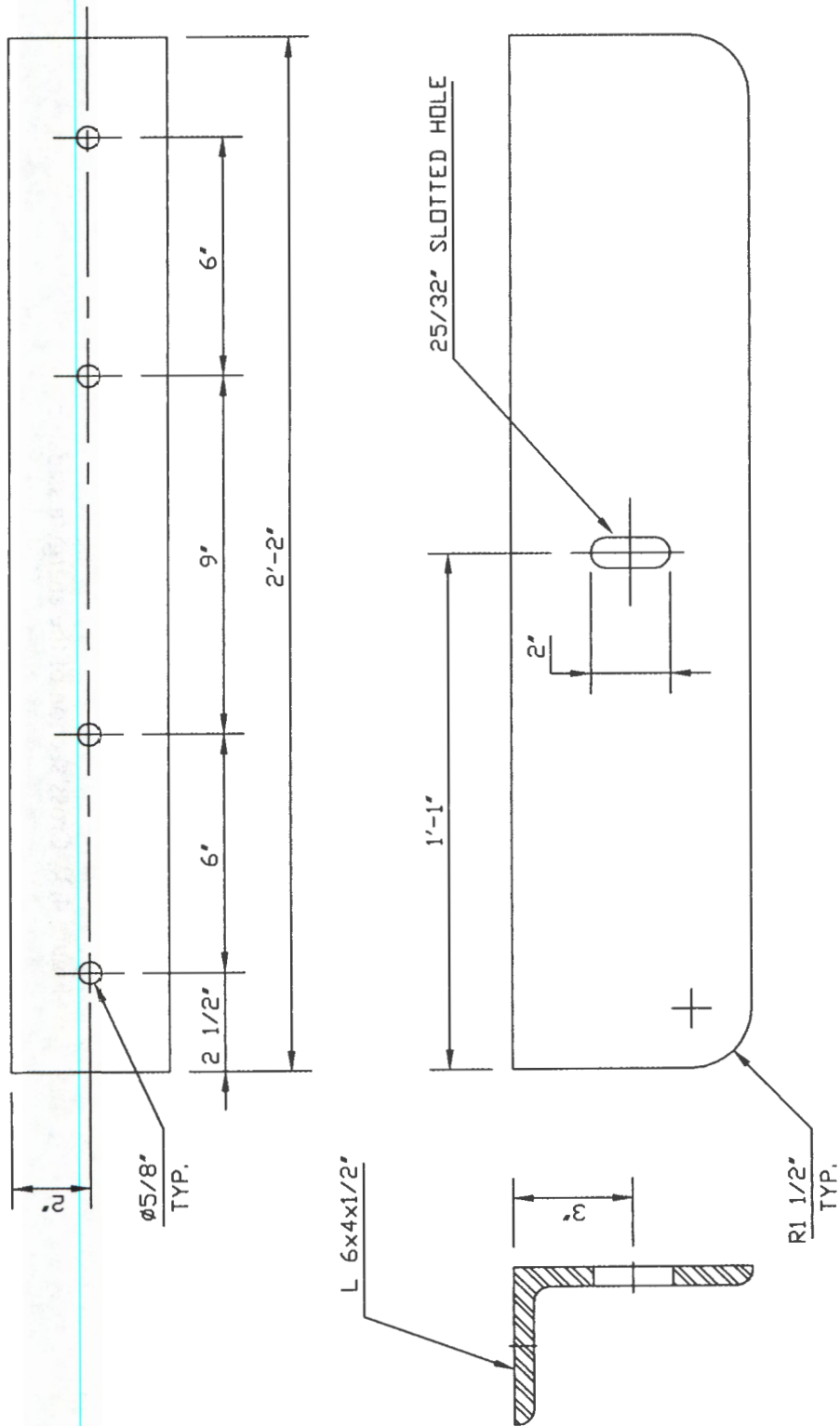

Figure 4.2. Angel details

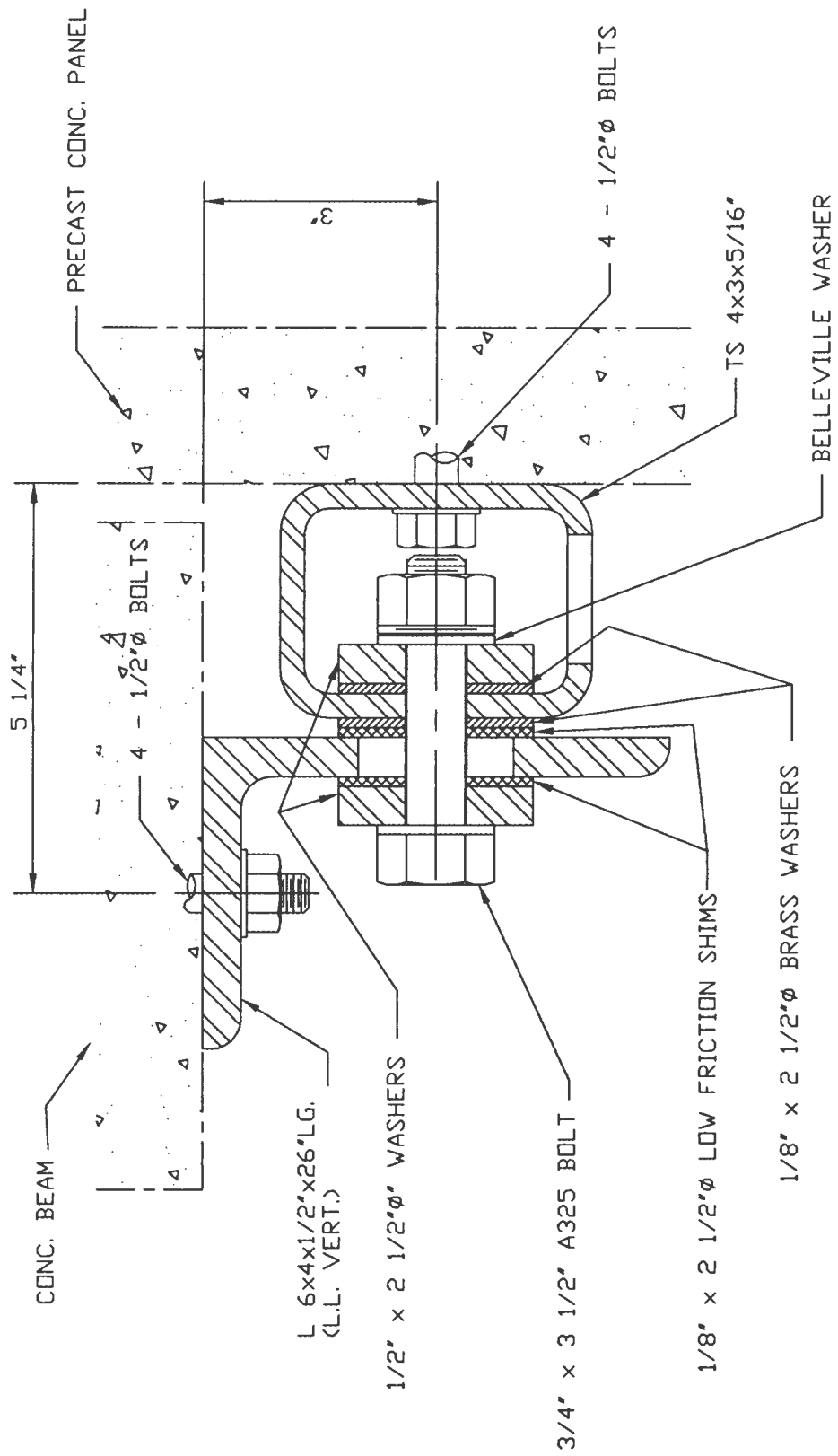
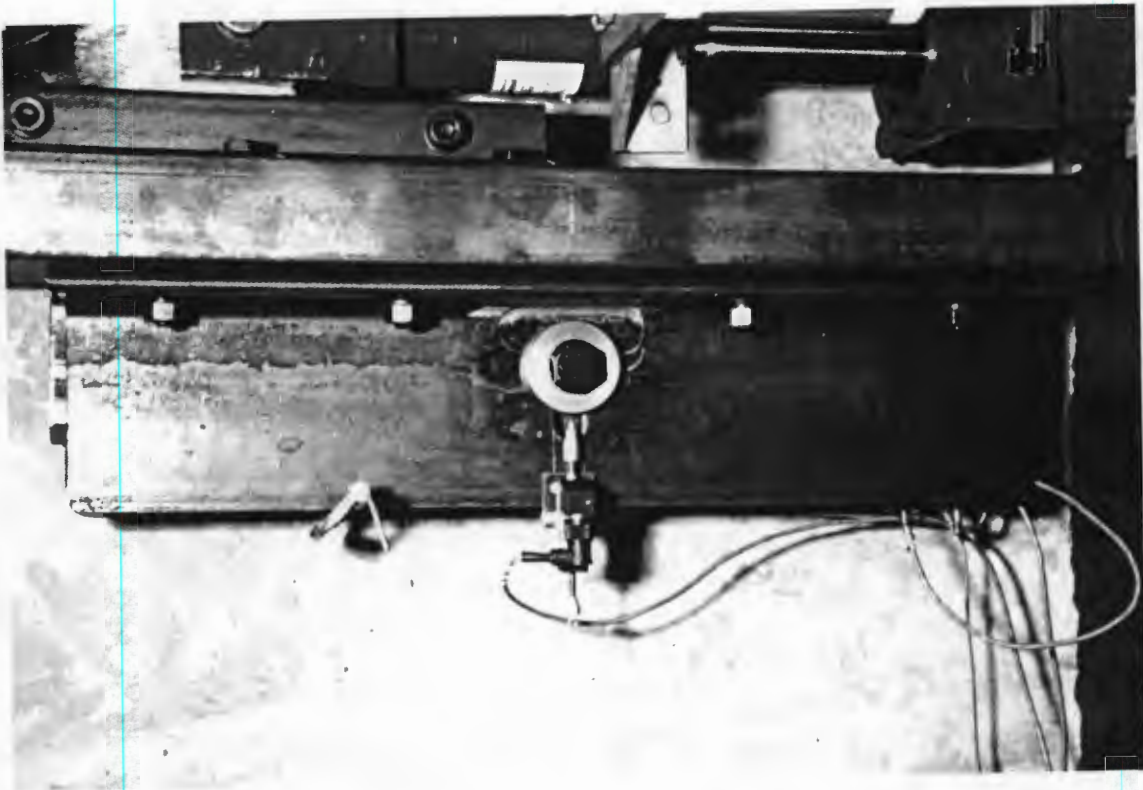

Figure 4.3. Cross section of the energy dissipator



(a)



(b)

Figure 4.4 (a) Steel tube, (b) Steel angel

5 ANCHORAGE SYSTEM

Two types of anchorage systems, fabricated by Hilti, were studied in this project.

a) Hilti Kwik Anchor Bolts

In the original design, the Hilti Kwik concrete anchorage without epoxy was used to connect the energy dissipating devices at the top and the fixed supports at the bottom to the panel. These bolts, shown in Fig. 5.1-a, include a nut, a washer, and an expandable head. They are installed by drilling a hole into the panel and placing the anchor bolt inside the hole. As the nut is tightened, the head at the end of the bolt expands, firmly attaching the end of the bolt to the perimeter of the concrete hole.

The bolts required to hold the energy dissipating devices at the top of the panels were anchored while the panel was lying down on the floor. The bottom supports were anchored to the panel in the vertical position, as seen in Fig. 5.1-b. Because of an error during the setup procedure, the gap between the bottom of the panel and the top of the bottom steel beam was $\frac{1}{4}$ " instead of 1", but as discussed below, this did not alter the response of the system. The panel with this kind of anchorage underwent significant rocking.

b) Hilti Hit HY-150 Adhesive Anchor System

To limit the rocking response, a new type of anchorage, Hilti Hit HY-150 Adhesive Anchor System, was used. These bolts, shown in Fig. 5.2-a, also require a hole to be pre-drilled in the concrete. Epoxy is injected inside the hole with a special tool, and then the bolts are inserted in the holes. The energy dissipating devices were anchored to the panel while the panel was in a horizontal position, lying down on the floor (Fig. 5.2-b). The base supports were connected to the panel while the panel was in place in a vertical position. Since the anchor bolt heads could not go through the over-sized holes provided in the steel supports, the studs were epoxied in the pre-drilled holes and then the supports were fit in place. (The diameter of the studs was $\frac{1}{2}$ " and the holes were $\frac{9}{16}$ " in diameter.) To do this process fast enough to prevent hardening of the epoxy before adjusting the supports, one person filled the holes with the epoxy and another person installed the anchor bolts (Figs. 5.3-a and 5.3-b).



(a)



(b)

Figure 5.1. (a) Hilti Kwik Anchor Bolt, (b) Bolt installation at the bottom support

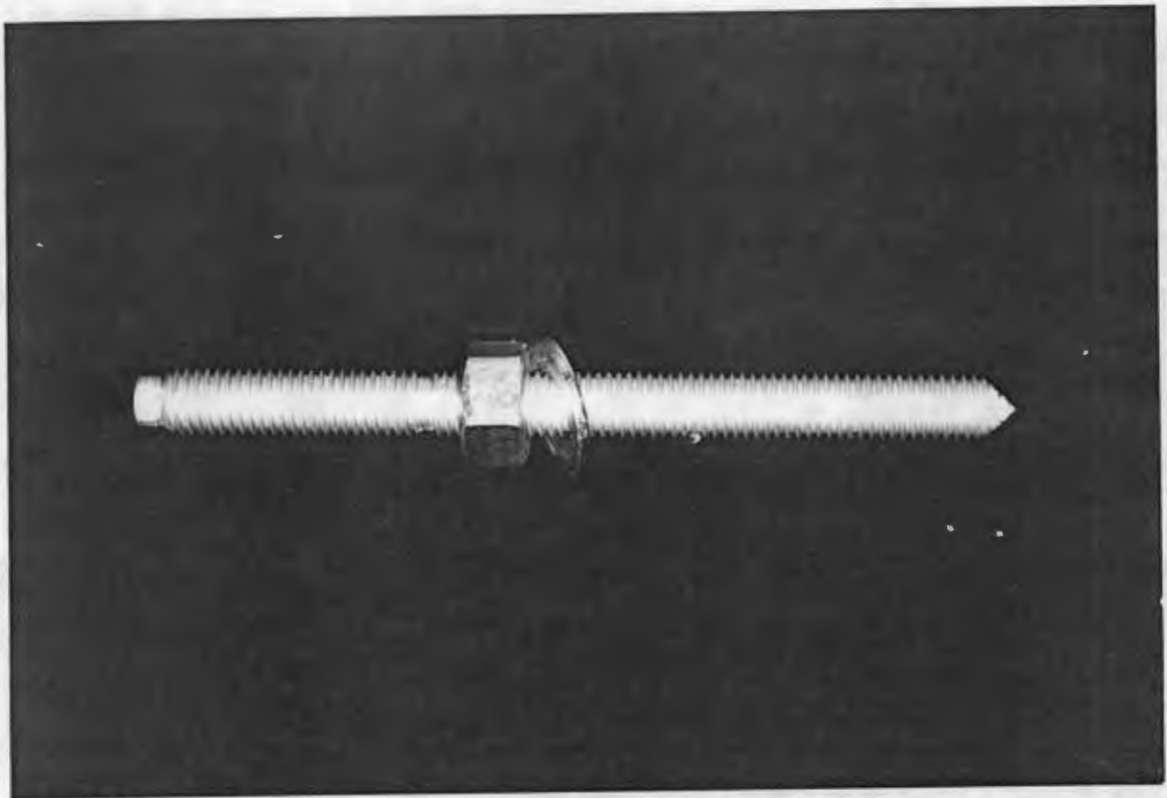

(a)

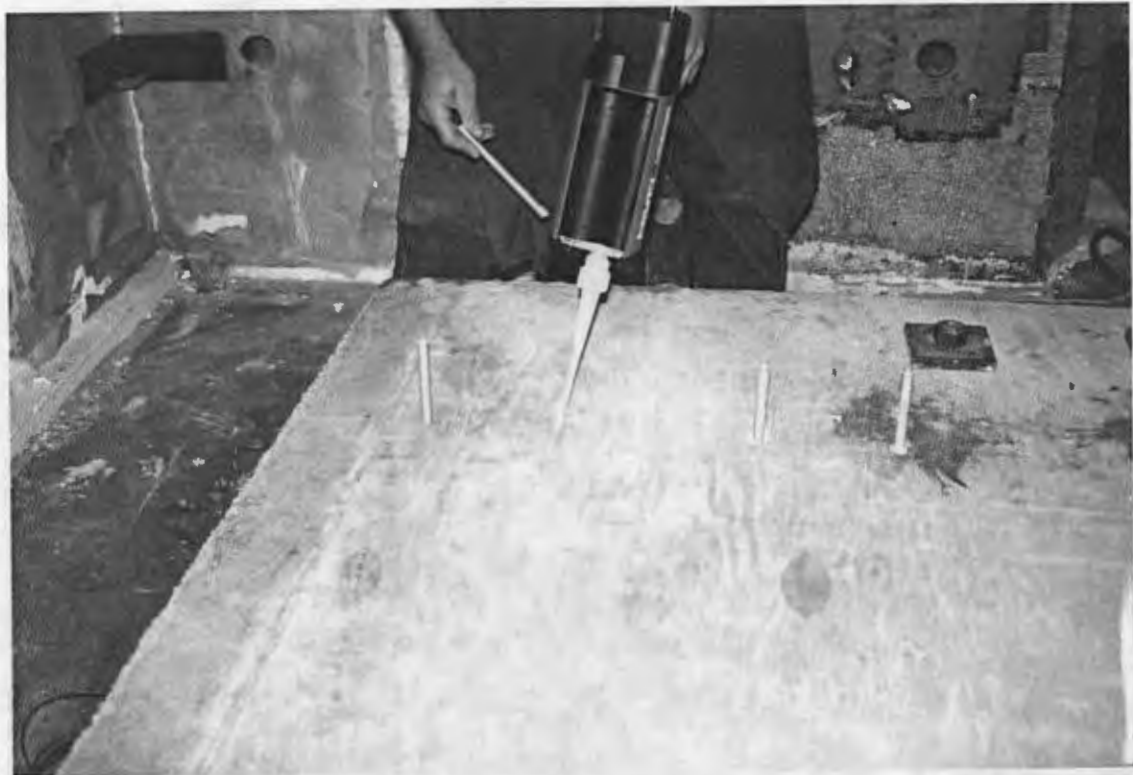

(b)

Figure 5.2. (a) Hilti Hit HY-150 Adhesive Anchor Bolt, (b) Installation at the top of the panel in a horizontal position



Figure 5.3. Installation of Hilti Hit HY-150 at the bottom support:
(a) injection of the epoxy, (b) installation of the studs

6 INSTRUMENTATION & DATA ACQUISITION

Many instruments were used to measure the applied loading and motions and the resulting response of the panel. Figure 6.1 provides a sketch of the instrumentation strategy. The applied load was measured with a load cell with a capacity of 30 kips connected to the actuator shaft. Displacement feedback, required to control the actuator was provided via a Temposonic displacement transducer.

The displacement of the panel at different location was monitored with linear potentiometers (Figs. 6.1 and 6.2). Two accelerometers were used to measure the acceleration of the carriage and the top of the panel.

Digital torque wrenches were used to apply the torque to tighten the bolts. This was indispensable to establish the capacity of the dissipators. The tension in the bolt was measured with a washer load cell.

All the instruments were connected to a computer-based data acquisition and control system. This system consisted of a Neff 470 box connected to a 50 MHz 486 PC running under the QNX operating system. Two Keithley DAS 1601 cards were installed in the computer to acquire the experimental data and to send the displacement command signal to an MTS controller connected to the actuator servovalve. The Autonet software was used to develop a computer program to generate and apply the required actuator displacement history and to read the instrumental measurements. Readings were stored in binary format (Autonet LDF) during tests and later the data were backed up and exported as ASCII text files through the Department's Ethernet network to another PC for processing.

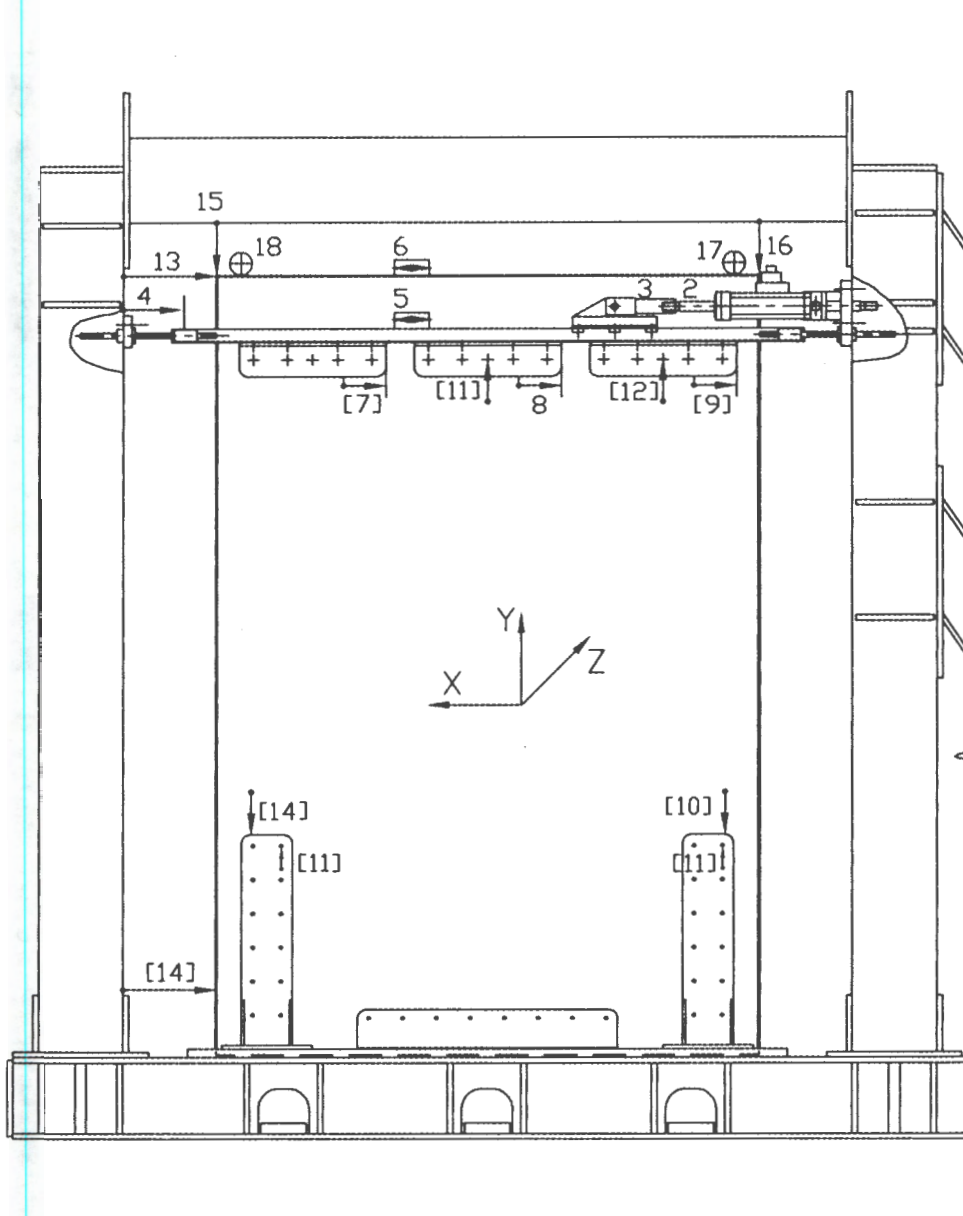

Note 1: Channels 1, 2, and 3 are the Command (not shown), the Temposonic, and the Load cell, respectively.

Note 2: Channels 5 and 6 are Accelerometers.

Note 3: All other instruments are Displacement Potentiometers.

Note 4: Channels with the numbers in the brackets have not been active all the time.

Figure 6.1. Instrumentation strategy

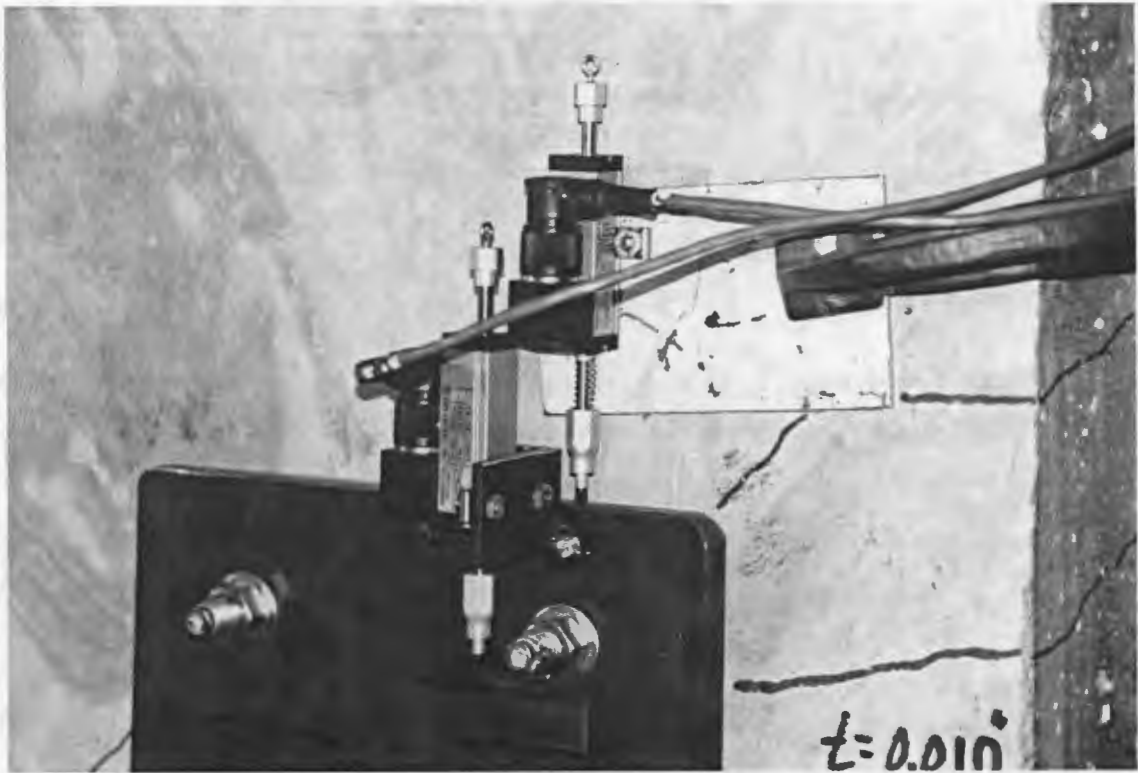
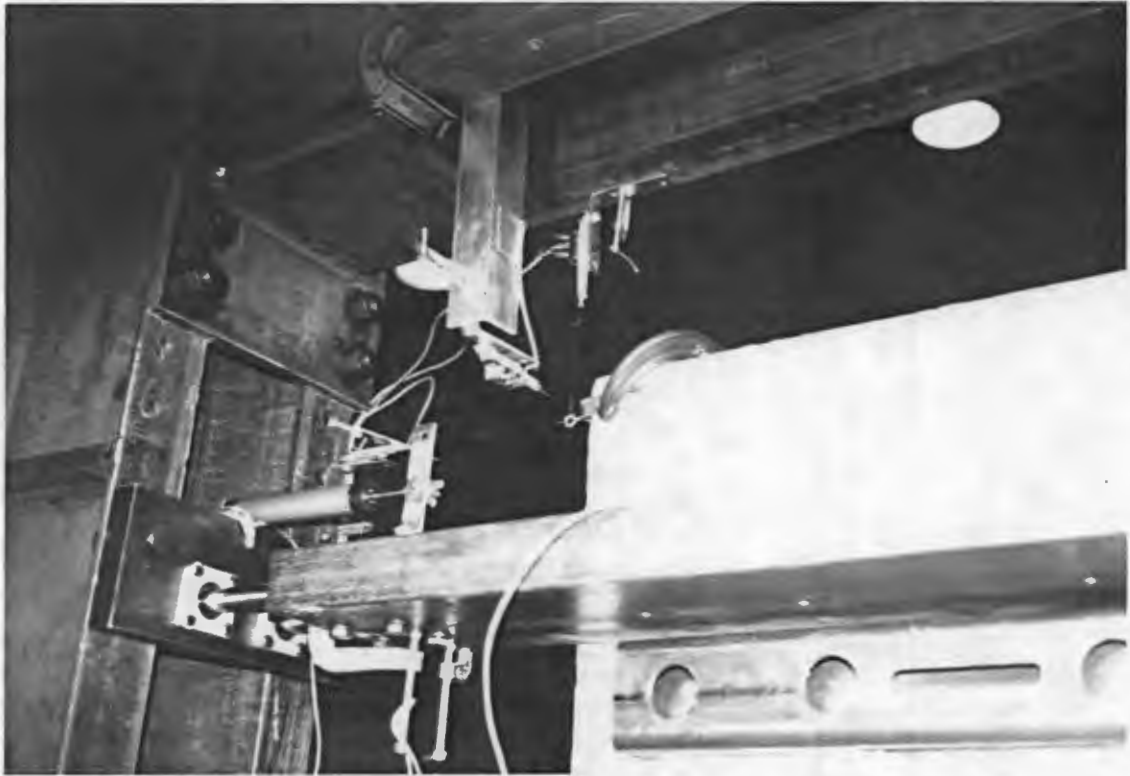

Figure 6.2. Linear potentiometers at different locations

7 TESTING PROGRAM

7.1 Selection of Input Signals

The system was subjected to a series of tests consisting of harmonic motions and simulated earthquake loading. The harmonic displacement was applied at various frequencies and amplitudes to study the dynamic characteristics of the system and to calibrate the energy dissipators to obtain the desired load level. Since the fundamental frequency of the library was reported to be about 1.5 Hz, it was decided to use a harmonic signal at this frequency as representative of extreme input motion. Nabih Youssef and Associates supplied a displacement time history, which represented the relative displacement between two adjacent floors of the library during an earthquake. This signal was to be applied with two amplitudes: 1.11 inches (100% seismic motion) and 1.65 inches (150% seismic motion). These two amplitudes represented the effects of a moderate and a severe earthquake, respectively. The testing schedule had therefore the following format:

- ◆ Several harmonic tests to study and calibrate system
- ◆ Extreme motion: 10 cycles of harmonic motion. Amplitude = 1.8 inches, frequency = 1.5 Hz
- ◆ Moderate earthquake: Seismic time history. Amplitude = 1.11 inches
- ◆ Severe earthquake: Seismic time history. Amplitude = 1.65 inches

The testing program is outlined in Table 7.1 and was conducted in two phases. During Phase A, the dissipators and the base support system were attached to the panel using Hilti Kwik anchor bolts. At the start of Phase B the wall was turned 180 degrees around axis X (see Fig. 6.1) and the dissipators and base support were connected to the panel using the Hilti Hit HY-150 Adhesive anchor system. The system was then tested under similar loading conditions as during Phase A.

The data acquired during the test was processed using the MATLAB language [2]. Plots summarizing the results from all tests are given in Appendix B.

Table 7.1. Testing program

Test #	Date	No. of Devices	Signal Type	Freq (Hz)	Ampl (in)	Torq (ft-lbs)	Washers	Anchorage Type ^(1,2)	File Name ⁽³⁾
1	05/22/97	1	Harmonic	0.1	2.0	0	Unpainted	A	05221001.txt
2	//	1	Harmonic	0.2	1.8	200	Unpainted	A	05221031.txt
3	//	1	Harmonic	0.2	1.8	100	Unpainted	A	05221403.txt
4	//	1	Harmonic	0.5	1.8	100	Unpainted	A	05221405.txt
5	//	1	Harmonic	0.5	1.8	100	Unpainted	A	05221433.txt
6	//	1	Harmonic	1.0	1.8	100	Unpainted	A	05221445.txt
7	//	1	Harmonic	1.5	1.8	100	Unpainted	A	05221454.txt
8	06/04/97	3	Harmonic	0.05	1.8	100	Painted	A	06041203.txt
9	//	3	Harmonic	0.05	1.8	150	Painted	A	06041214.txt
10	06/10/97	3	Harmonic	0.05	1.8	100	Painted	A	06101049.txt
11	//	3	Seismic	--	1.1	100	Painted	A	06101117.txt
12	//	3	1.5 * Seismic	--	1.65	100	Painted	A	06101134.txt
13	//	3	Harmonic	1.5	1.8	100	Painted	A	06101148.txt
14	06/27/97	3	Harmonic	0.05	1.8	50	Painted	B	06271234.txt
15	//	3	Harmonic	0.05	1.8	100	Painted	B	06271255.txt
16	//	3	Seismic	--	1.1	100	Painted	B	06271329.txt
17	//	3	1.5 * Seismic	--	1.65	100	Painted	B	06271349.txt
18	//	3	Harmonic	1.5	1.8	100	Painted	B	06271410.txt
19	//	3	Harmonic	1.5	0.5	100	Painted	B	06271435.txt
20	//	3	Harmonic	1.5	1.8	100	Painted	B	06271440.txt
21	//	3	Harmonic	1.5	1.8	100	Painted	B	06271509.txt
22	//	3	Harmonic	1.5	1.8	150	Painted	B	06271531.txt
23	//	3	Harmonic	1.5	1.8	200	Painted	B	06271553.txt

¹A = HITI KWIK

²B = HILTI HIT HY-150 (Epoxyed)

³mmdhmm.txt

7.2 PHASE A: Panel with Hilti Kwik Concrete Anchorage

Test No. 1: Friction of Loading System

The first test was conducted to measure the force required to move the carriage system. The carriage was not connected to the panel. The full load was therefore transmitted to the carriage only. The input signal was 10 cycles of harmonic motion with 2 inches amplitude at a frequency of 0.1 Hz. Figure 7.1 shows that, after overcoming a static resistance of about 200 lbs, the force required to displace the carriage was significantly reduced. Notice that the cycles are not symmetrical probably because of non-zero initial force. The friction in the carriage system was considered to be small compared to the lateral loads applied later to the system.

Tests 2 through 7: Behavior of System with Single Dissipator

Only one dissipator was connected and tested under harmonic displacement. The target sliding force for the dissipator was 6 kips. According to preliminary tests, the bolt tension required was about 14 kips (Appendix A, Section A-4), and the corresponding tightening torque was about 250 ft-lb (Appendix A, Section A-3). Conservatively, the bolt was tightened with a 200 ft-lb torque.

Test No. 2 was programmed to be ten 1.8-inch cycles at 0.2 Hz. Figure 7.2 summarizes the response of the system during the first two cycles. Many conclusions and observations can be drawn from the graphs presented in this figure. Letter subheadings below correspond to those of the plots in the figure.

- a) The actuator displacement followed closely the prescribed displacement command signal.
- b) and c) The top of the panel moved noticeably. The maximum double amplitude of horizontal and vertical displacements were 0.55" and 0.18", respectively. The maximum horizontal and vertical displacements were 0.30" and 0.15", respectively. Note that the maximum vertical downward displacement of about 0.15" was still below the 0.25" gap at the bottom of the panel. Since the flexural deformation of the panel was small, compared to the displacement of the panel at the top, the alternating sign of the vertical motions of the left and right ends of the panel suggested rocking of the wall.
- d) The maximum horizontal displacement measured at the base was very small (0.014").
- e) There was a noticeable out-of-plane displacement at the top of the panel. The left and right ends of the wall moved out of phase, indicating that the top of the wall was twisting with respect to a vertical axis. This motion was mainly caused by the eccentricity of about 3" of the loading system with respect to the base support plane, the flexibility of the carriage, and because a single connector was attached to the center of the panel.

- f) Since in this test, the relative displacement between the tube and angel sections was not measured directly, the relative displacement between the sliding components of the dissipator was estimated from the absolute displacement measurements (with respect to frame) of the panel and the carriage. The total lateral load force vs. relative displacement relationship recorded was very stable, with full hysteresis loops.
- g) The absolute displacement (i.e. displacement of the loading carriage system) range was somewhat larger than the relative displacement range, due to the movement of the top of the panel.
- h) The applied load was practically constant when the dissipator was sliding. The peak load was about 10 kips, significantly larger than the target load of 6 kips.
- i) Most of the input energy was dissipated by the energy-dissipating device.
- j) The acceleration at the top of the panel was small.

The test was stopped before the ten cycles were completed because of significant wall rocking, and because the sliding force (10 kips) was higher than the target load (6 kips). This indicated that the system used to study slippage force (Appendix A, Section A-4) was not representative of the dissipators, most probably because the two systems were built with steels of different quality.

To reduce the load in the dissipator, the bolts were retightened with 100 ft-lb torque. The system was then tested with two cycles at 0.2 Hz (Test No. 3). Figure 7.3 shows that the target-slipping load of 6 kips was achieved, and that bolt tension was relatively constant, close in magnitude to the lateral force. Since there were two sliding surfaces, the coefficient of friction was about 0.5.

UCR Rivera Library—Test No. 1 Anchorage A One Device (T=0 ft-lbs)
Harmonic Motion (0.1 Hz, 2 in) File: 05221001.txt

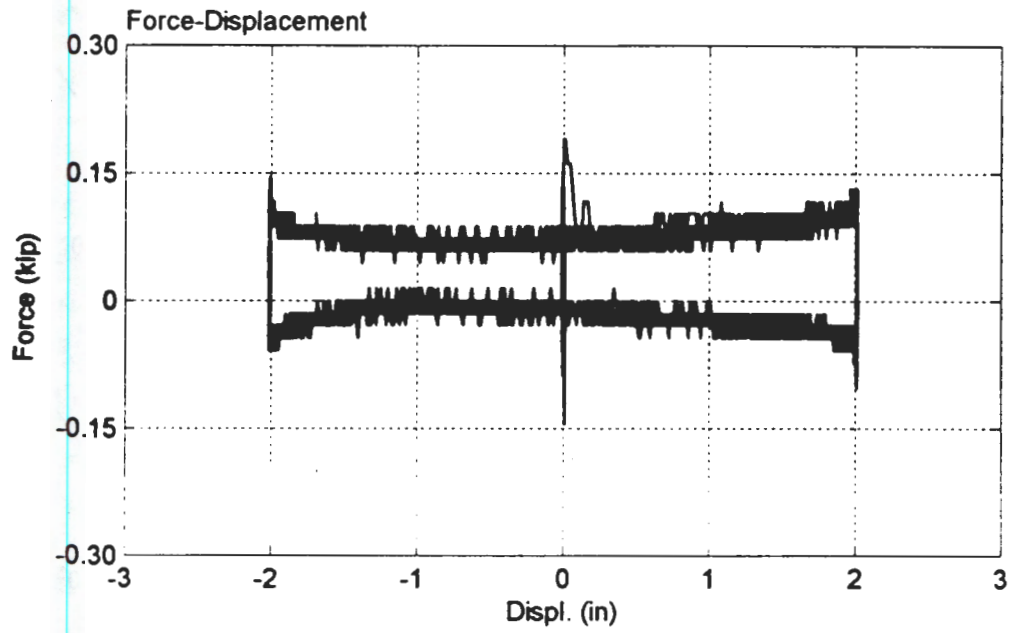

UCR Rivera Library--Test No. 2 Anchorage A One Device (T=200 ft-lbs)
Harmonic Motion (0.2 Hz, 1.8 in) File: 05221031.txt

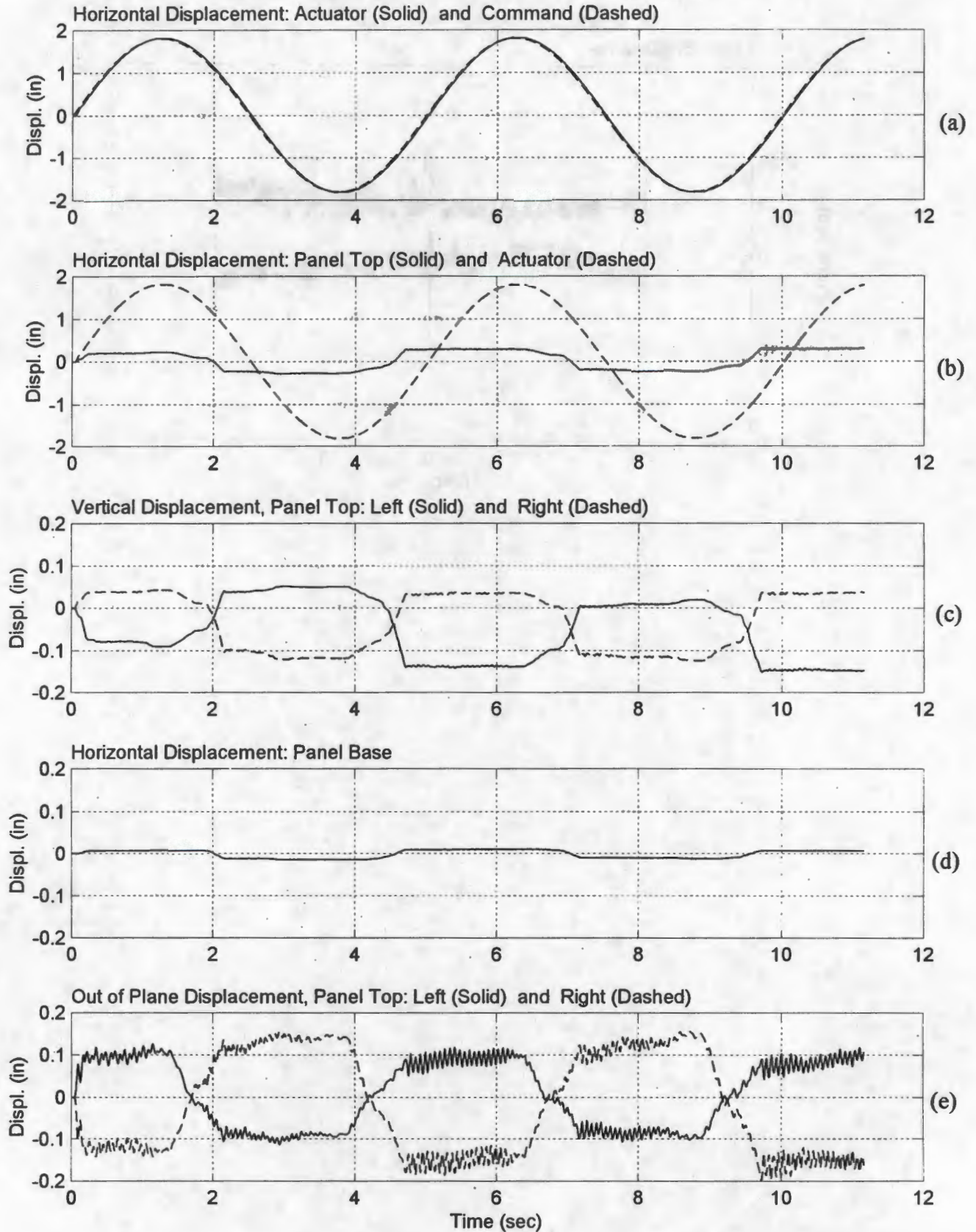

Figure 7.2 Test results (cont'd)

UCR Rivera Library--Test No. 2 Anchorage A One Device (T=200 ft-lbs)
Harmonic Motion (0.2 Hz, 1.8 in) File: 05221031.txt

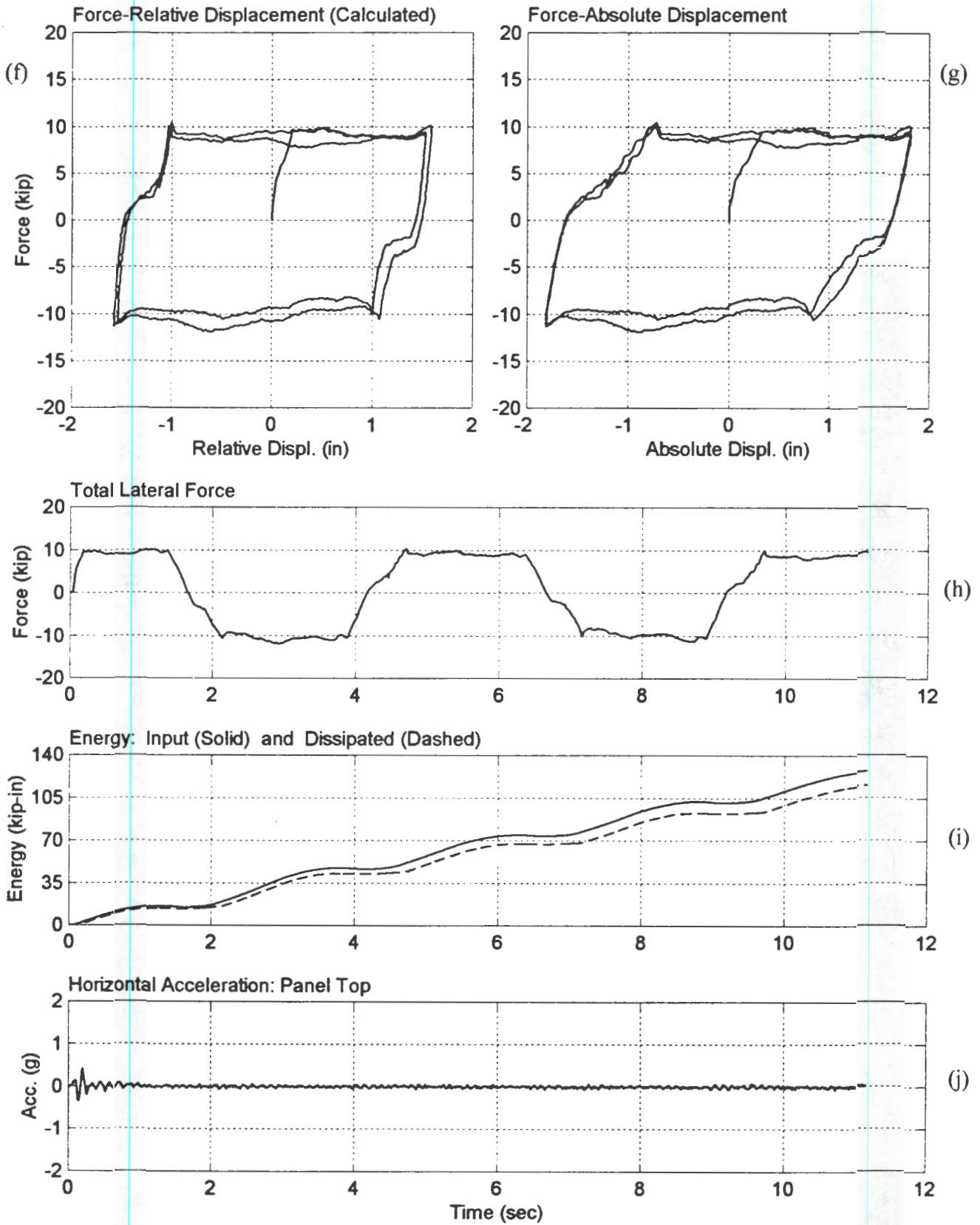
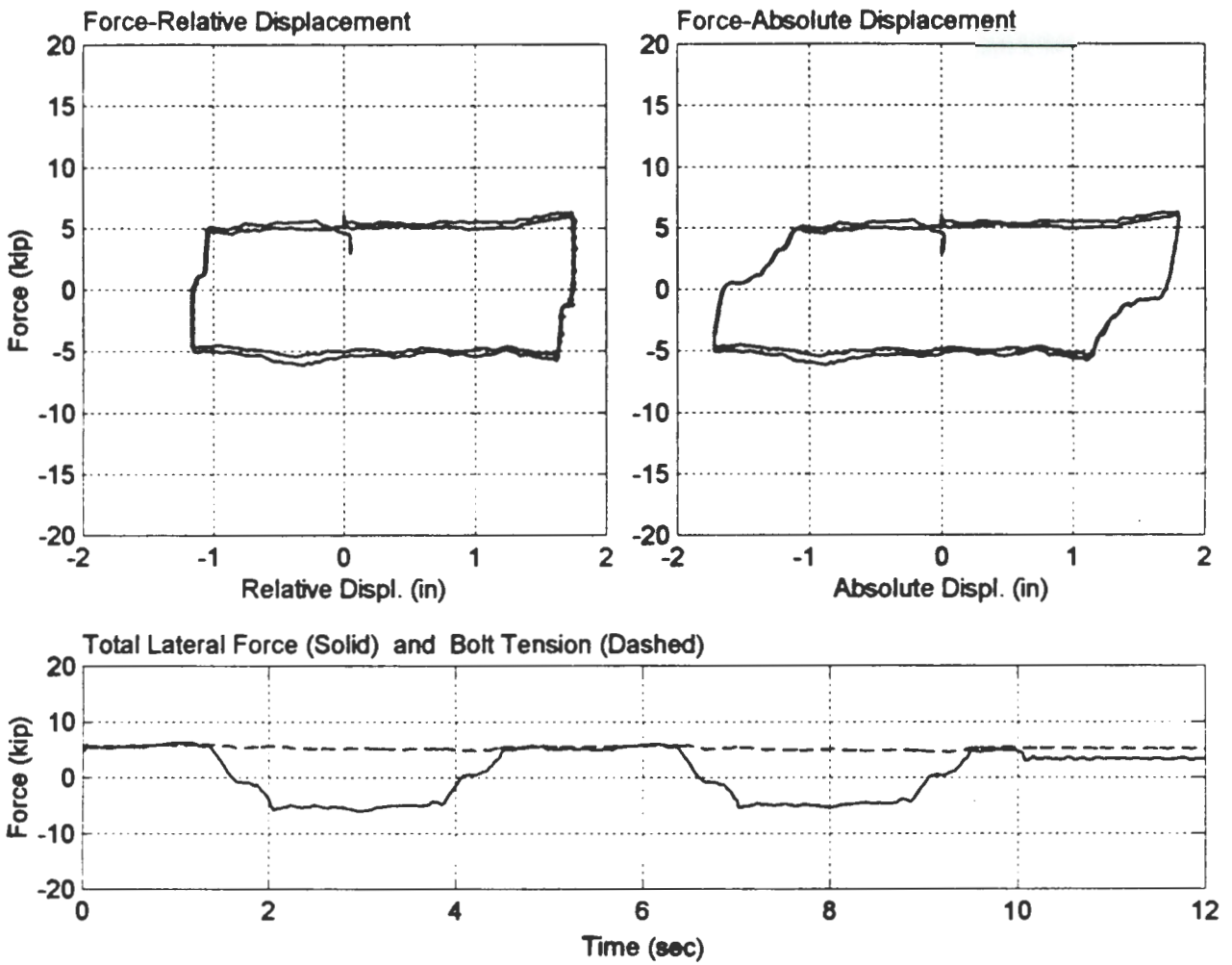

Figure 7.2 Test results

UCR Rivera Library—Test No. 3 Anchorage A One Device (T=100 ft-lbs)
Harmonic Motion (0.2 Hz, 1.8 in) File: 05221403.txt



Tests No. 4 through 7 consisted of harmonic motion of successively increasing frequency, with 1.8-inch amplitude. Test No.4 was performed at 0.5 Hz. Significant vertical relative displacement between bottom supports and panel was noticed. It was then decided to install a displacement transducer to measure this motion. The test was then repeated (Test No. 5). The frequency of the input motion was increased to 1 Hz for Test No. 6 and to 1.5 Hz for Test No. 7.

Figure 7.4 presents the main results of Test No. 7 and summarizes the effect of increasing the frequency of the input motion on the response of the test apparatus and the behavior of the dissipators and the panel.

- a) The actuator was not able to follow accurately the command signal. Amplitude overshoot and phase lag were considerable, mainly because of the capacity of the hydraulic system and probably because the input frequency was close to the resonant frequency of the hydraulic system.
- b) The horizontal displacement at the top of the panel was significant. Due to transducer saturation, however, only the measurements in the negative direction (to the right) were reliable. Although beyond some positive displacement, the potentiometer did not record the displacement, examining Fig. 7.4 (c) and (d), it is obvious that in that direction, the displacements were much smaller than in the other (i.e. negative direction) which means that the real positive displacement is not much different from what is recorded.
- c) The vertical motion of the top of the panel was not symmetrical, indicating that the wall moved more in one direction than in the other. This could have been caused by an initial offset of the panel in the positive direction (to the left).

There was a noticeable sliding of the panel with respect to the vertical bottom supports. This motion, also unsymmetrical for this test, was an indication that the bottom support anchors were not sufficiently rigid to prevent rocking of the panel.

Two sets of washers were used during these first seven tests. Figure 7.5 shows considerable abrasion of the washers after the test. The steel tube also presented visible marks. This means that the system also dissipates energy through gouging the washers.

UCR Rivera Library—Test No. 7 Anchorage A One Device (T=100 ft-lbs)
Harmonic Motion (1.5 Hz, 1.8 in) File: 05221454.txt

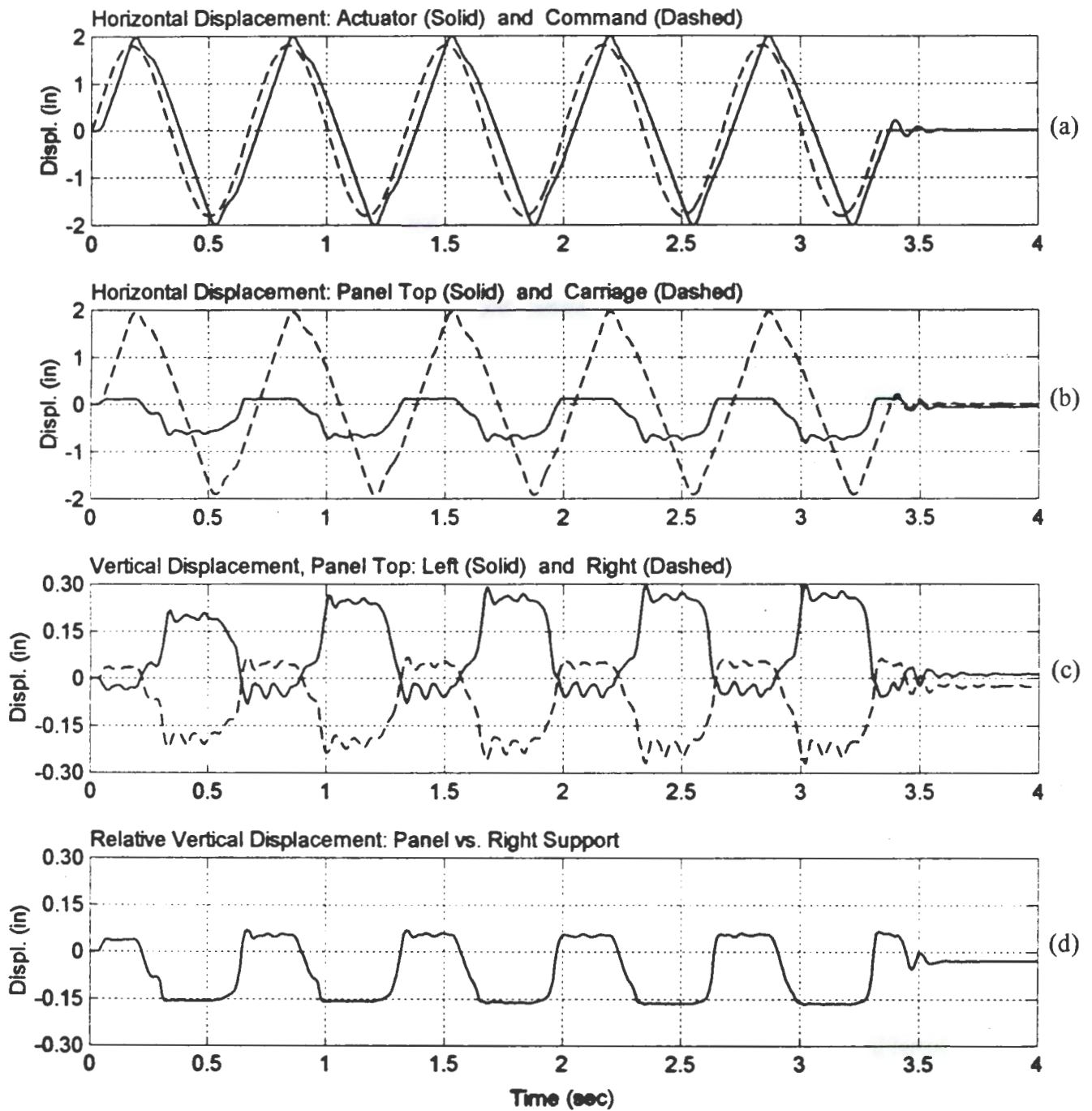
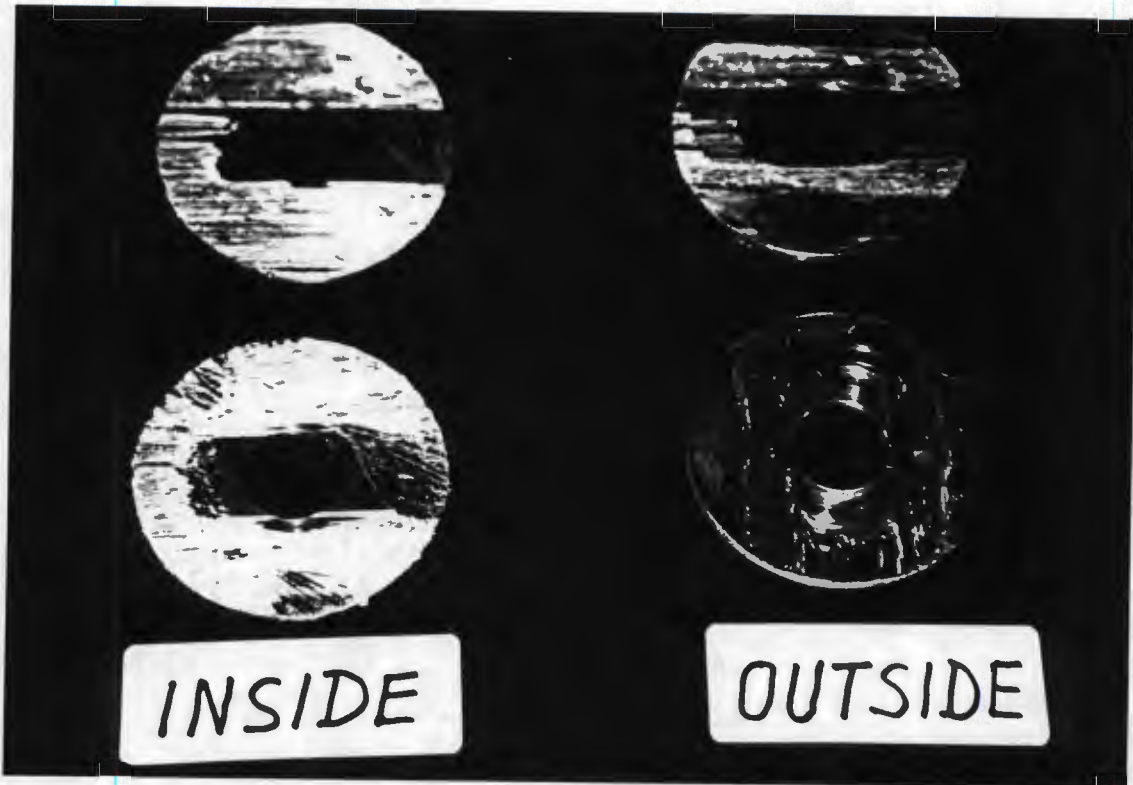
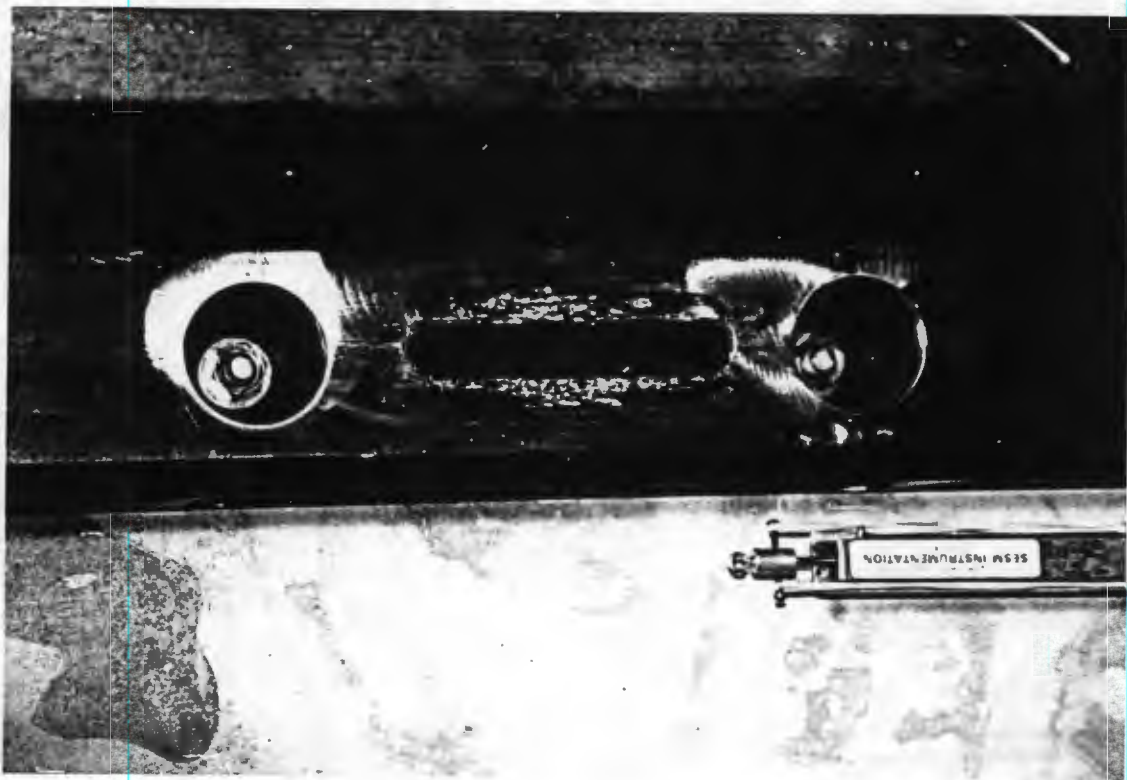

Figure 7.4 Test results



(a)



(b)

Figure 7.5. (a) Brass washers after the first seven tests, (b) Brass mark on the steel tube section

Tests 8 through 10: Behavior of System with Three Dissipators

All three energy dissipators were activated for this portion of the testing program. The target peak lateral load to be transmitted by the three connections was 18 kips.

The tests with one dissipator indicated that the torque required to obtain 6 kips in one connector was 100 lb-ft. Accordingly, all three bolts were tightened with a torque of 100 ft-lbs to reach a sliding force of 18 kips. Test No. 8 was conducted at a very low frequency (1.8-inch amplitude at 0.05 Hz). The peak lateral force measured during this test was only 13 kips. Assuming that all the bolts are under the same tension force of about 7 kips, and considering that there are six active friction surfaces, the coefficient of friction was about 0.3. This value is considerably lower than the coefficient of 0.5 obtained under similar conditions with only one dissipator.

To increase the sliding load of the connectors, the bolts were tightened with a torque of 150 ft-lbs, and the system was tested again (Test No. 9). The lateral load was increased to about 17 kips, as shown in Fig. 7.6. The tension in the bolts was 8.5 kips; therefore the coefficient of friction was now about 0.35. This increase in the coefficient of friction was probably due to wear in the washers and the steel contact surfaces. During this test the panel cracked due to the high shear load applied by the energy dissipators (Fig. 7.7).

In spite of the shear cracking of the panel and the rocking of the system due to the flexibility of the bottom connectors, it was decided to lower the tension in the bolts and proceed with the testing program. New brass washers were installed in the connectors. The washers were painted with primer (Fig. 7.8) to investigate whether this protective measure had any effect on the response of the system. The system was checked with 2 cycles at 0.05 Hz with 1.8-inch amplitude (Test No. 10). The peak lateral load measured was 14.4 kips, which was considered adequate.

UCR Rivera Library--Test No. 9 Anchorage A Three Devices (T=150 ft-lbs)
Harmonic Motion (0.05 Hz, 1.8 in) File: 06041214.txt

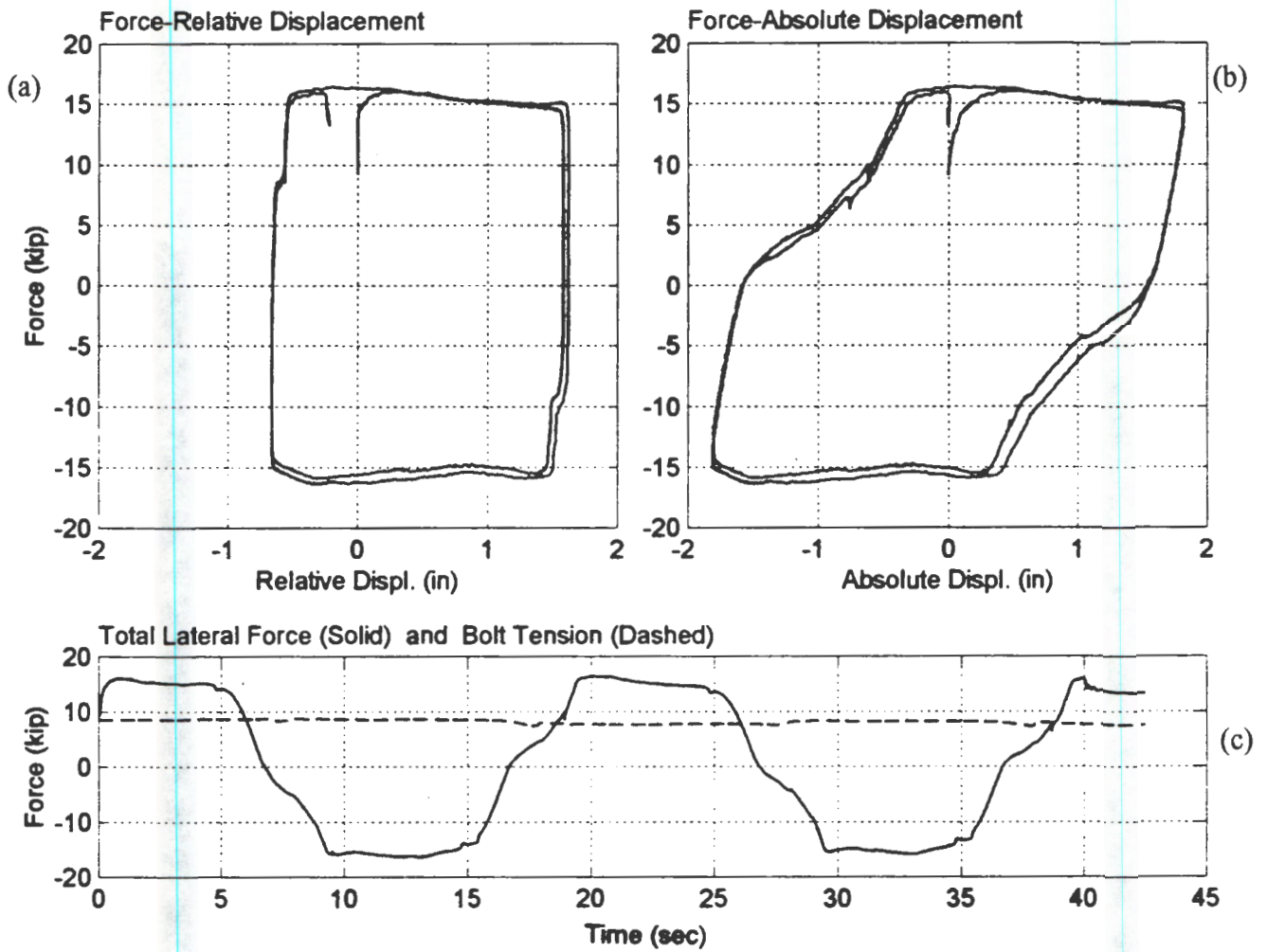

Figure 7.6 Test results

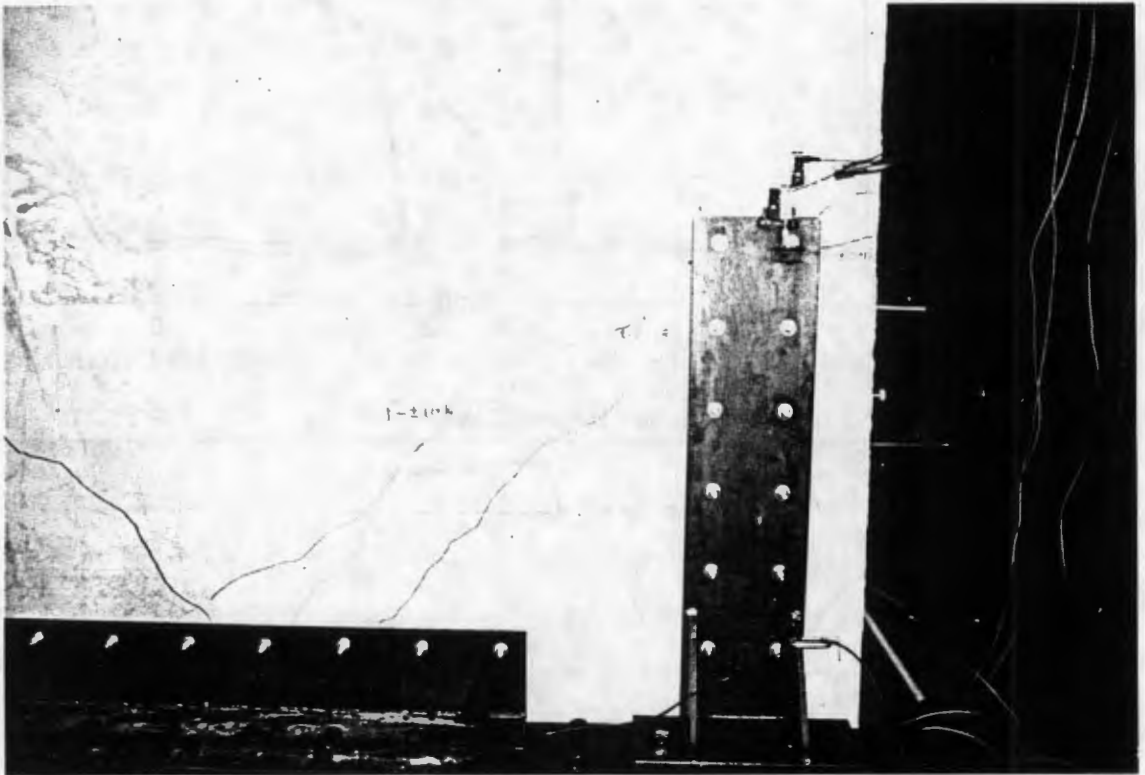

Figure 7.7. Cracked panel after test no. 7

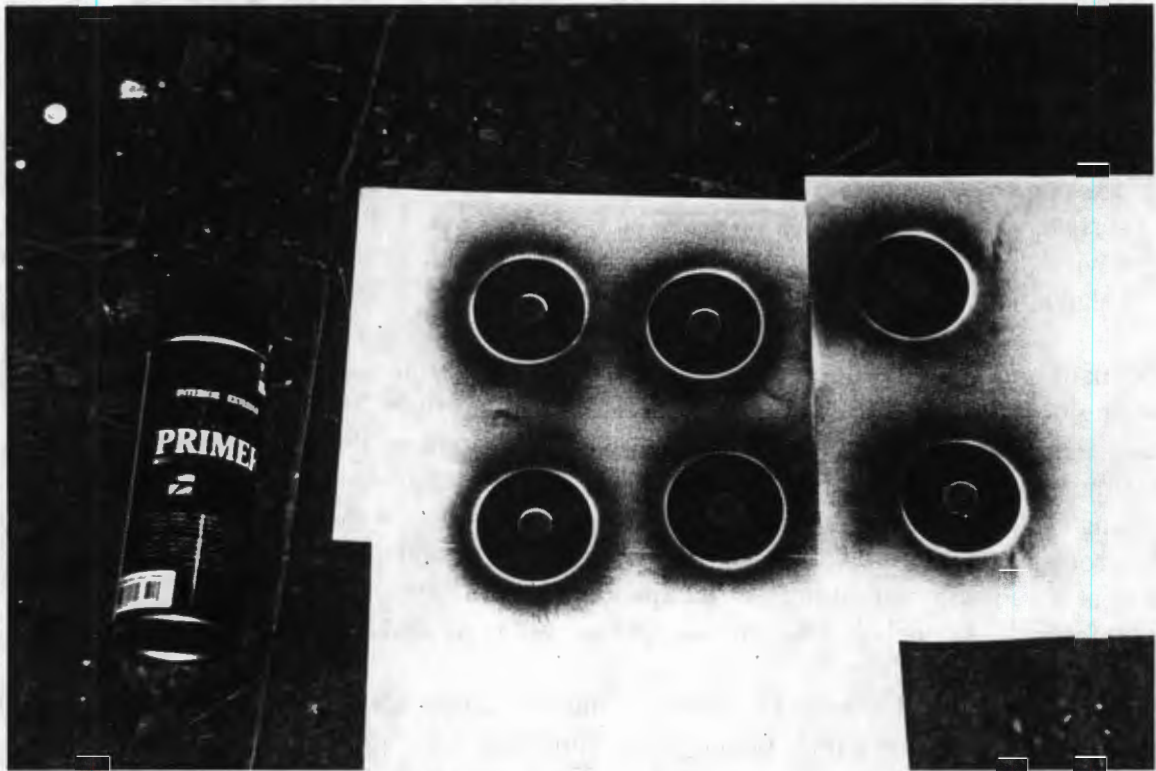

Figure 7.8. Painted brass washers

Tests 11 through 13: Main Tests with Three Dissipators

Test No. 11 was a simulated earthquake motion with amplitude of 1.11 inches. Significant rocking of the panel was observed during the test. Figure 7.9 summarizes the results obtained:

- a) The actuator followed accurately the seismic displacement command signal.
- b) The top of the panel moved significantly, following somewhat the movement of the actuator. There was a permanent displacement of the panel at the end of the test.
- c) The energy-dissipating devices dissipated only about 17% of the input energy.
- d) and e) The relative displacement between the two sliding components of the energy dissipators (tube & angle) was small compared with the displacement imposed by the loading system. This indicates that most of the time there was little sliding at the energy dissipating devices. The hysteresis loops were thin, and the system showed limited energy dissipation behavior.

The main reason for the limited energy dissipation performance of the system was the excessive rocking of the panel due to the flexibility of the connections between the base supports and the panel. Looking at Fig. 7-9-b, the max top displacement of the panel is about 0.8", while the maximum input displacement is only 1.1". This top displacement was mainly caused by the rocking of the panel, i.e. by the relative displacement between the panel and the bottom supports. This rocking motion prevented the effective sliding motion of the moving components of the dissipator. The contribution of the panel to the lateral top displacement is insignificant. Therefore it was concluded that the anchorage system needed to be redesigned.

During Tests No. 12 and 13, which simulated severe seismic loading, the system also experienced noticeable panel rocking. See Appendix B for summary plots of these tests. Panel rocking was mainly due to the way the Hilti Kwik bolts are anchored. They were attached to the concrete mainly in their end regions, where the expansive head locked against the perimeter of the concrete hole. Therefore the bolts were rotating like rigid elements, with significant lateral flexibility within the oversized drilled holes.

In order to minimize rocking of the panel and improve the energy dissipation characteristics of the system, an alternate anchorage system was investigated in Phase B of this project.

UCR Rivera Library—Test No. 11 Anchorage A Three Devices (T=100 ft-lbs)
 Seismic Motion (Max. Ampl.=1.1 in) File: 06101117.txt

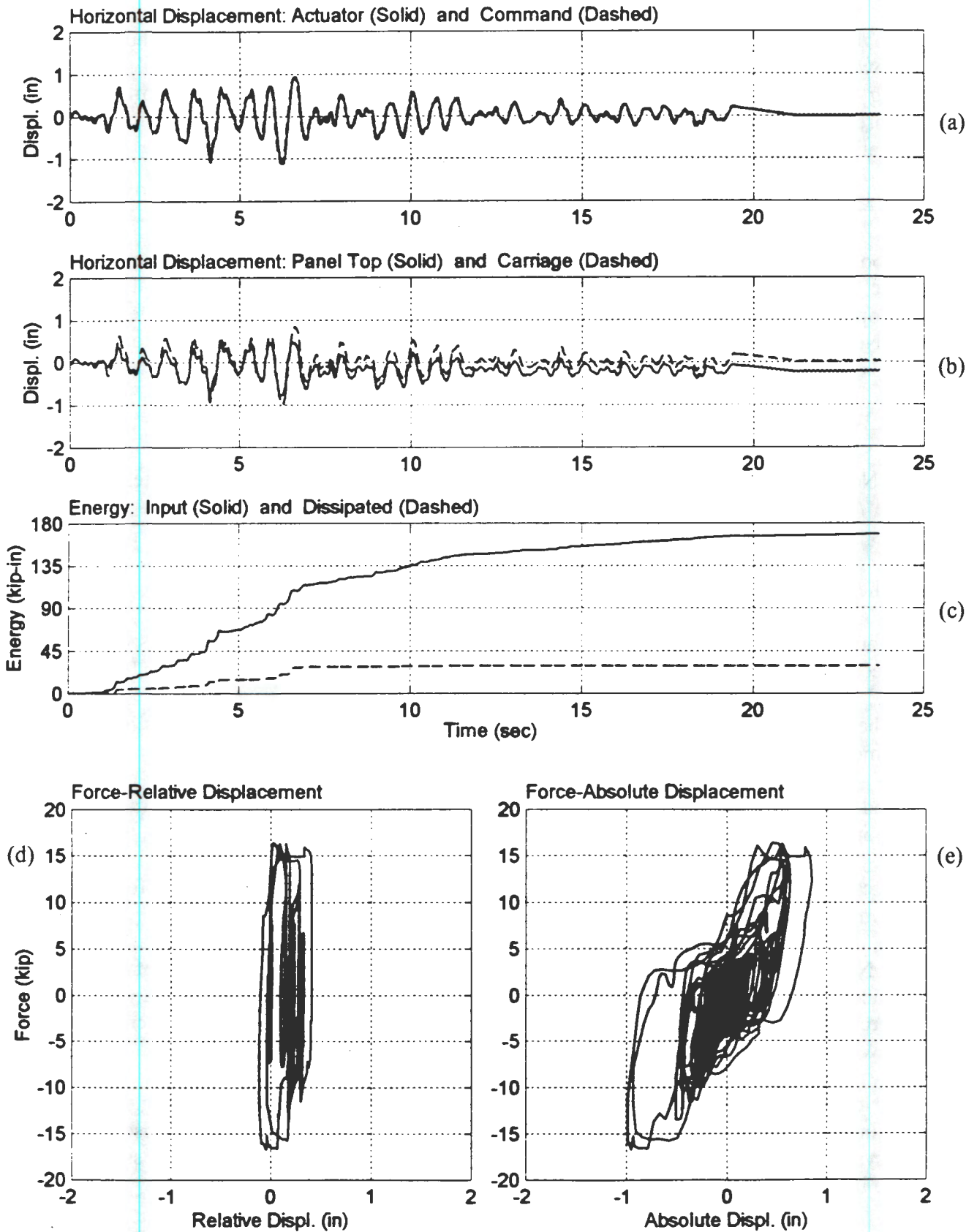

Figure 7.9 Test results

7.3 PHASE B: Panel with Hilti Hit HY-150 Adhesive Anchor System

These bolts were selected because they are fully epoxied to the concrete, thus providing improved anchorage of the bolts and lateral stiffness. Since the bottom of the wall was cracked during Phase A, the panel was flipped over. In this manner the bottom supports were now anchored to an uncracked region of the panel. The three dissipators were connected to the top of the wall. The nuts of the bottom connection were tightened up after each test.

Tests 14 and 15: System Calibration

The bolts were first tightened with at relatively low torque of 50 lb-ft, and the system was subjected to a slow (0.05 Hz) harmonic motion during Test No. 14. The total lateral load developed by the dissipators was 6.7 kips. It was then decided to increase the torque to 100 lb-ft. Test No. 15 was as slow as the previous test, and the load applied by the connectors was about 15 kips, which was deemed acceptable.

Tests 16 through 18: Main Tests

Test No. 16 was a seismic motion with amplitude of 1.1 inches, identical to test No. 11 in Phase A. The only difference between these two tests was the anchorage system. Figure 7.10 shows the test results (compare with Fig. 7.9, Test No. 11).

- a) The actuator followed accurately the command signal.
- b) Rocking of the panel, evidenced by the motion of the top of the panel, was substantially decreased from that observed during Test 11 (approximately 0.40 inches versus 0.75 inches).
- c) The energy-dissipating devices dissipated about 53% of the input energy. This is about three times higher than what was achieved with the other anchorage system.
- d) and e) The lateral force versus relative movement (sliding) plot shows a few full hysteresis loops, twice as wide as those obtained with the previous anchorage system.

This test showed that the epoxied bolts provided an acceptable anchoring system for the bottom support of the panel.

Test No. 17 simulated extreme earthquake conditions by imposing 150% of the seismic displacement amplitude (1.65 inches). The system had good seismic performance, with full hysteretic loops and dissipation of 60% of the input energy (Fig. 7.11). The panel cracked with a somewhat symmetrical pattern, as shown in Fig. 7.12.

Test No. 18 was a severe harmonic motion, with eleven 1.8-in cycles at 1.5 Hz (Fig. 7.13). Panel cracking increased significantly and some nuts from the base support became loose (Fig. 7.14). The system showed excellent energy dissipation characteristics during this test, dissipating 90% of the input energy.

UCR Rivera Library—Test No. 16 Anchorage B Three Devices (T=100 ft-lbs)
Seismic Motion (Max. Ampl.=1.1 in) File: 06271329.txt

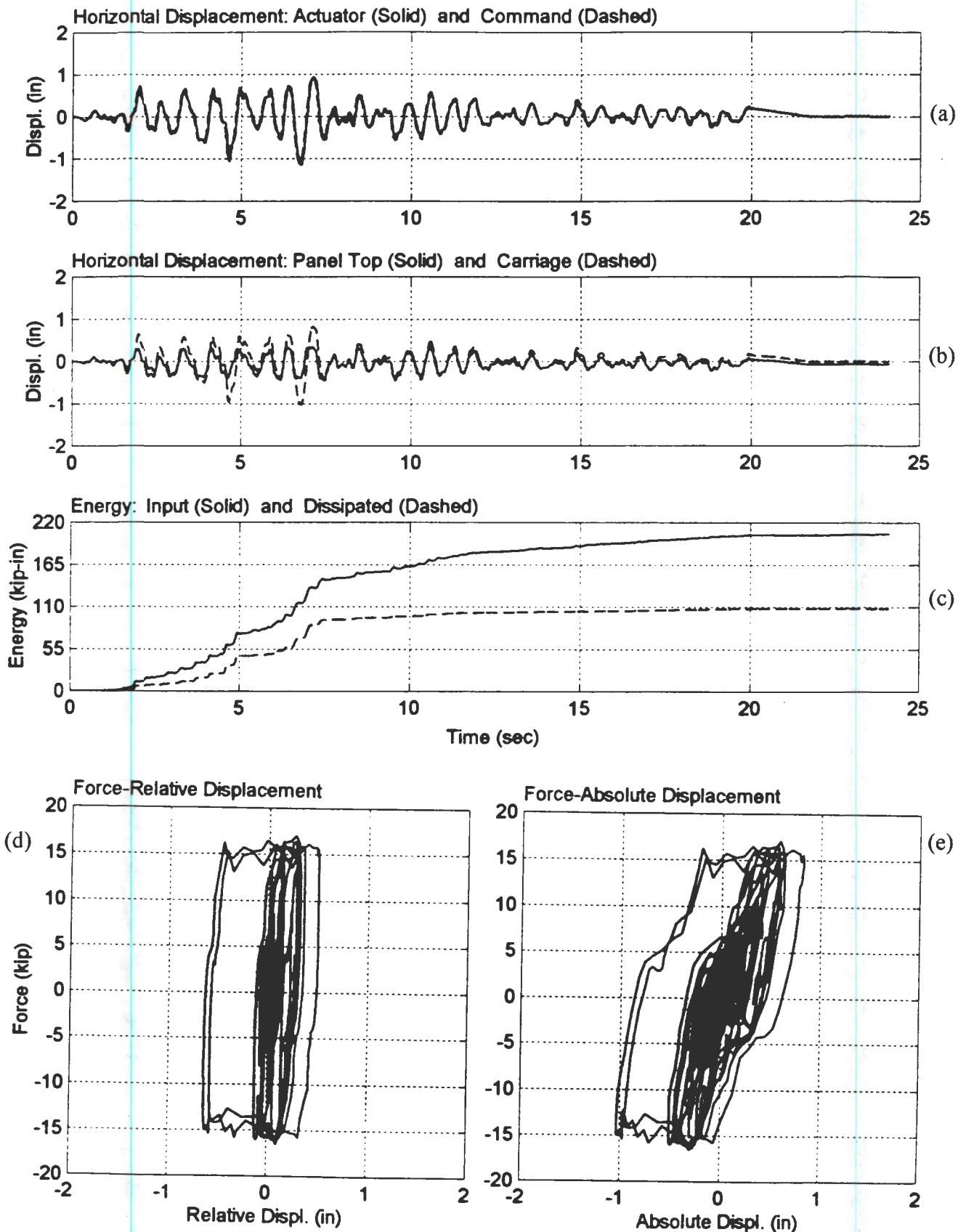

Figure 7.10 Test results

UCR Rivera Library--Test No. 17 Anchorage B Three Devices (T=100 ft-lbs)
Seismic Motion (Max. Ampl.=1.65 in) File: 06271349.txt

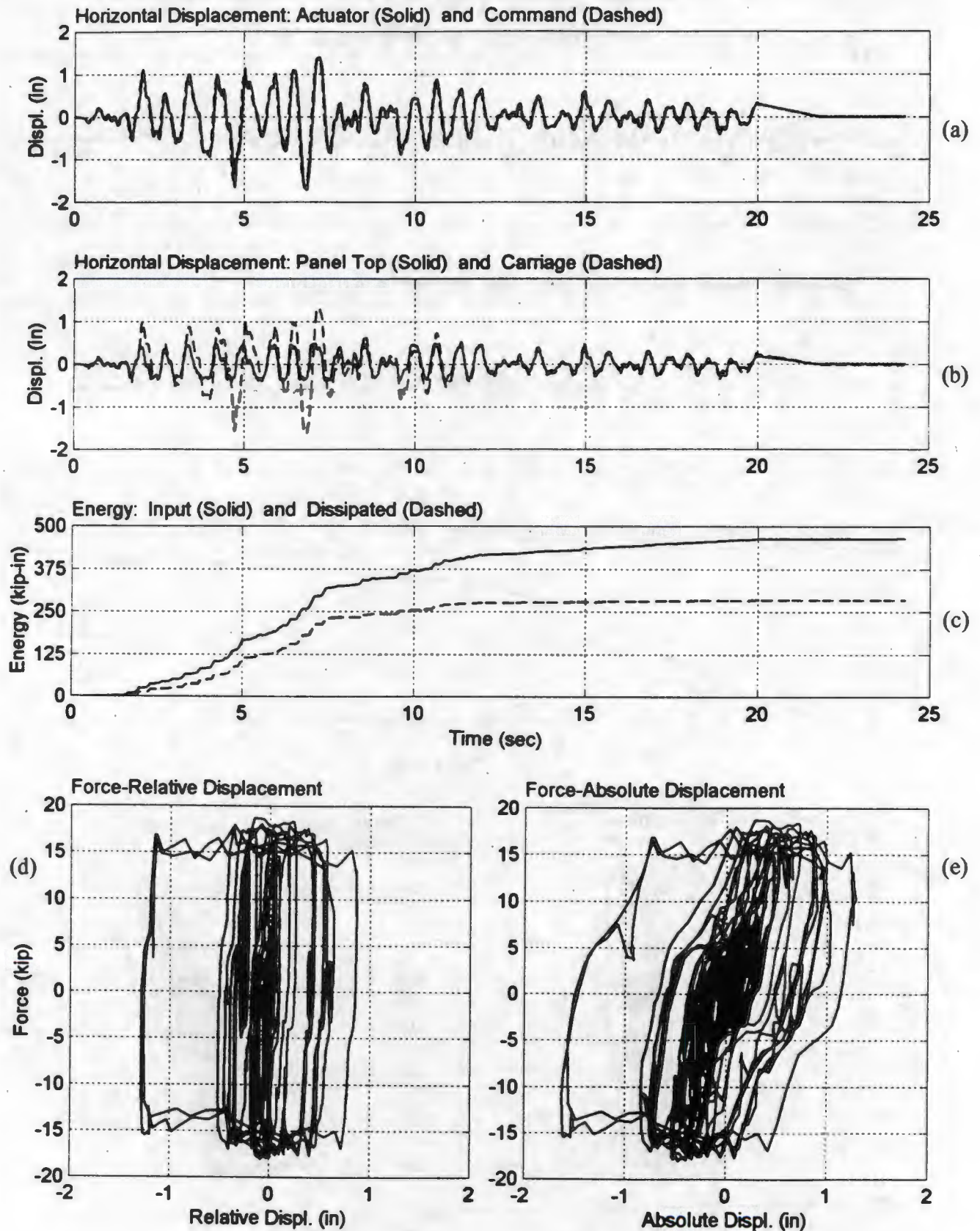

Figure 7.11 Test results

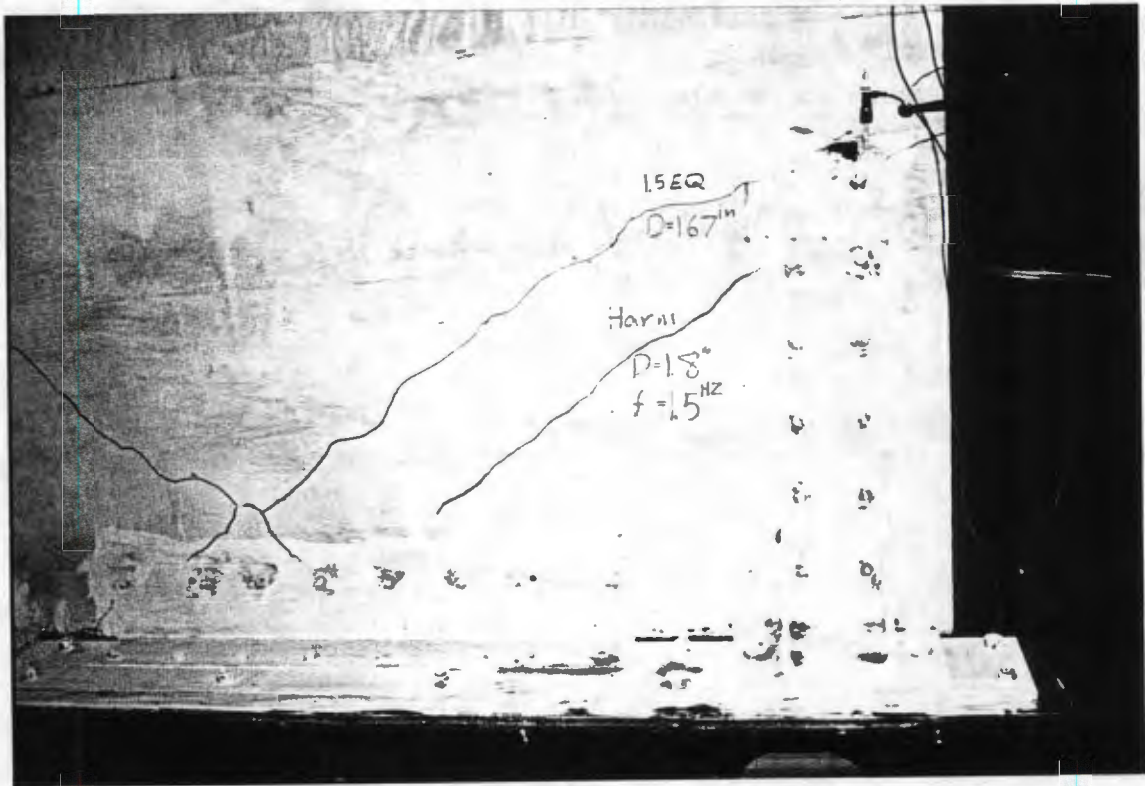

Figure 7.12. Panel cracking after test no. 17

UCR Rivera Library—Test No. 18 Anchorage B Three Devices (T=100 ft-lbs)
 Harmonic Motion (1.5 Hz, 1.8 in) File: 06271410.txt

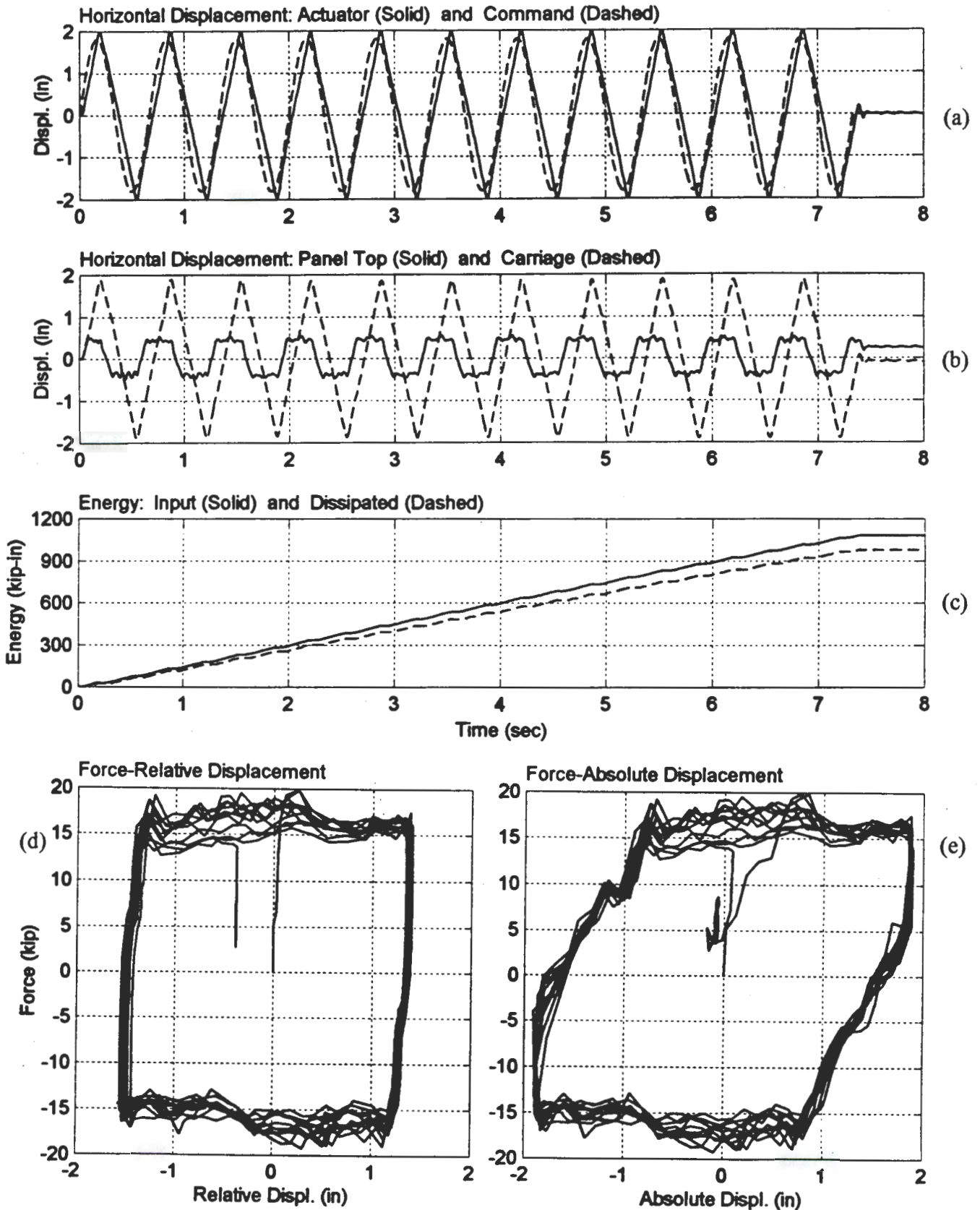

Figure 7.13 Test results



Figure 7.14. Some nuts loosened up after test no. 18

Tests 19 to 23: Further studies

Further studies were performed to understand better the behavior of the dissipation system, beyond the specifications of the system designers. To study the response of the system to low seismic input, a harmonic motion with amplitude of 0.5 inches was applied in Test No. 19. Figure 7.15 summarizes the results of this test. Plot b in Fig. 7.15 shows that during the test the panel and the carriage moved together in the positive direction (to the left), and that there was some relative motion (i.e. sliding) only in the negative direction. This indicates that the dissipators were not activated most of the time, as evidenced by the insignificant amount of energy dissipated by the system (plot c) and by the thin hysteretical loops (plots d and e).

Tests No. 20 and 21 consisted of severe harmonic motion, to induce additional damage in the panel. The dissipators performed quite well. Appendix C includes graphs summarizing these tests.

The effect of increasing the tension in the bolts was studied during Tests Nos. 22 and 23. For Test No. 22, bolt tension increased to 150 ft-lb. Sliding started at about 30 kips and reduced slowly with shaking, perhaps because of wearing of the sliding surfaces. Bolt tension was reasonably stable. (Figure 7.16.)

For Test No. 23, the tightening torque was increased to 200 lb-ft. The resulting bolt tension was about 10 kips. Figure 7.17 shows the test results. There was very little relative motion between the panel and the carriage, indicating that the dissipators were locked most of the time because of the high tension in the bolt (plot b). Consequently, the hysteresis loops were quite thin, and the amount of energy dissipated very small, as seen in plots c and e, respectively. Figure 7.18 shows the crack pattern after this test. The state of one of the brass and teflon washers can be appreciated from Figure 7.19; it can be seen that the teflon washer was completely crushed. Finally, Figs. 7.20 and 7.21 show the studs after the last test. Looking carefully, it can be seen that the epoxy around the studs is almost intact.

UCR Rivera Library—Test No. 19 Anchorage B Three Devices (T=100 ft-lbs)
Harmonic Motion (1.5 Hz, 0.5 in) File: 06271435.txt

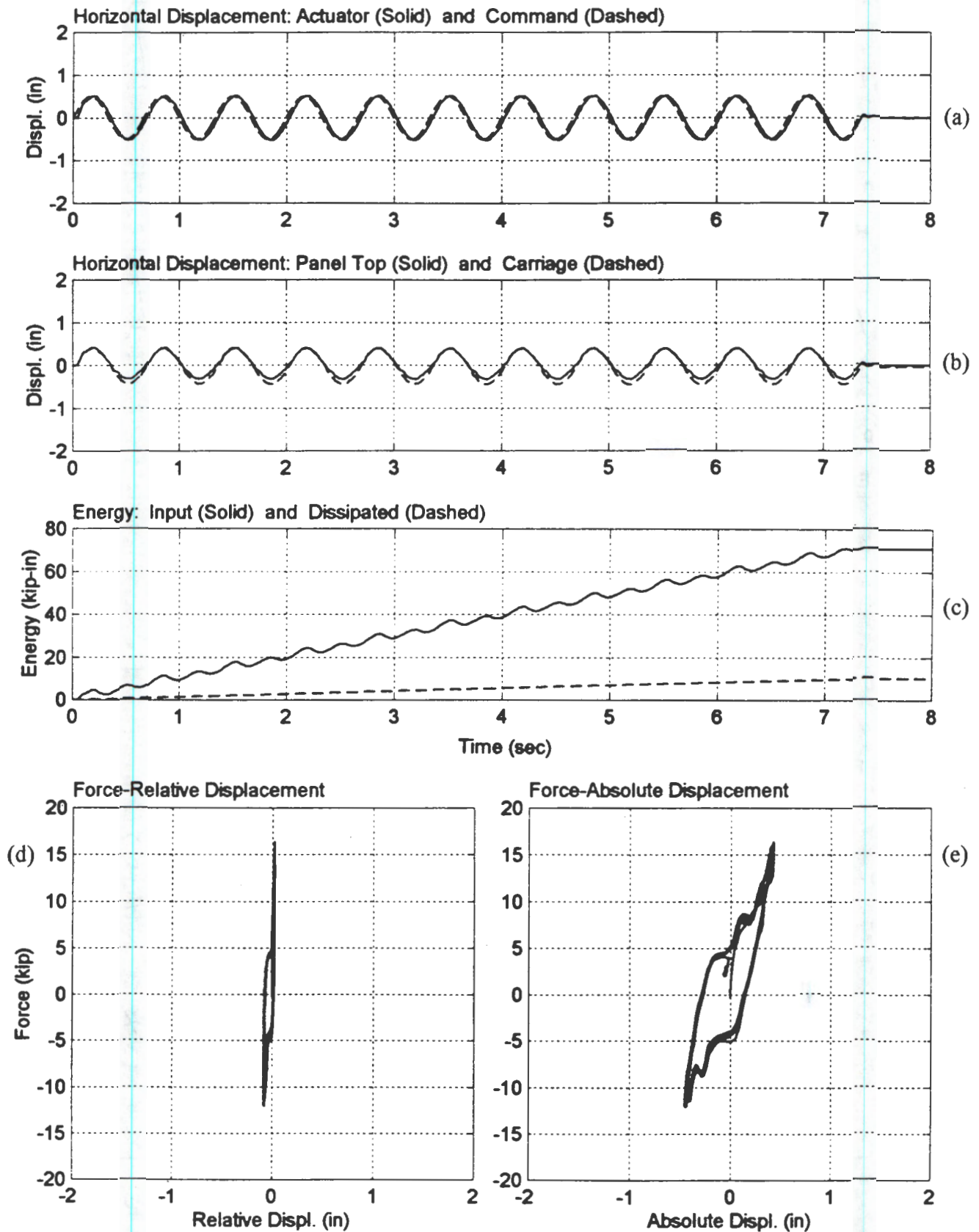

Figure 7.15 Test results

UCR Rivera Library—Test No. 22 Anchorage B Three Devices (T=150 ft-lbs)
Harmonic Motion (1.5 Hz, 1.8 in) File: 06271531.txt

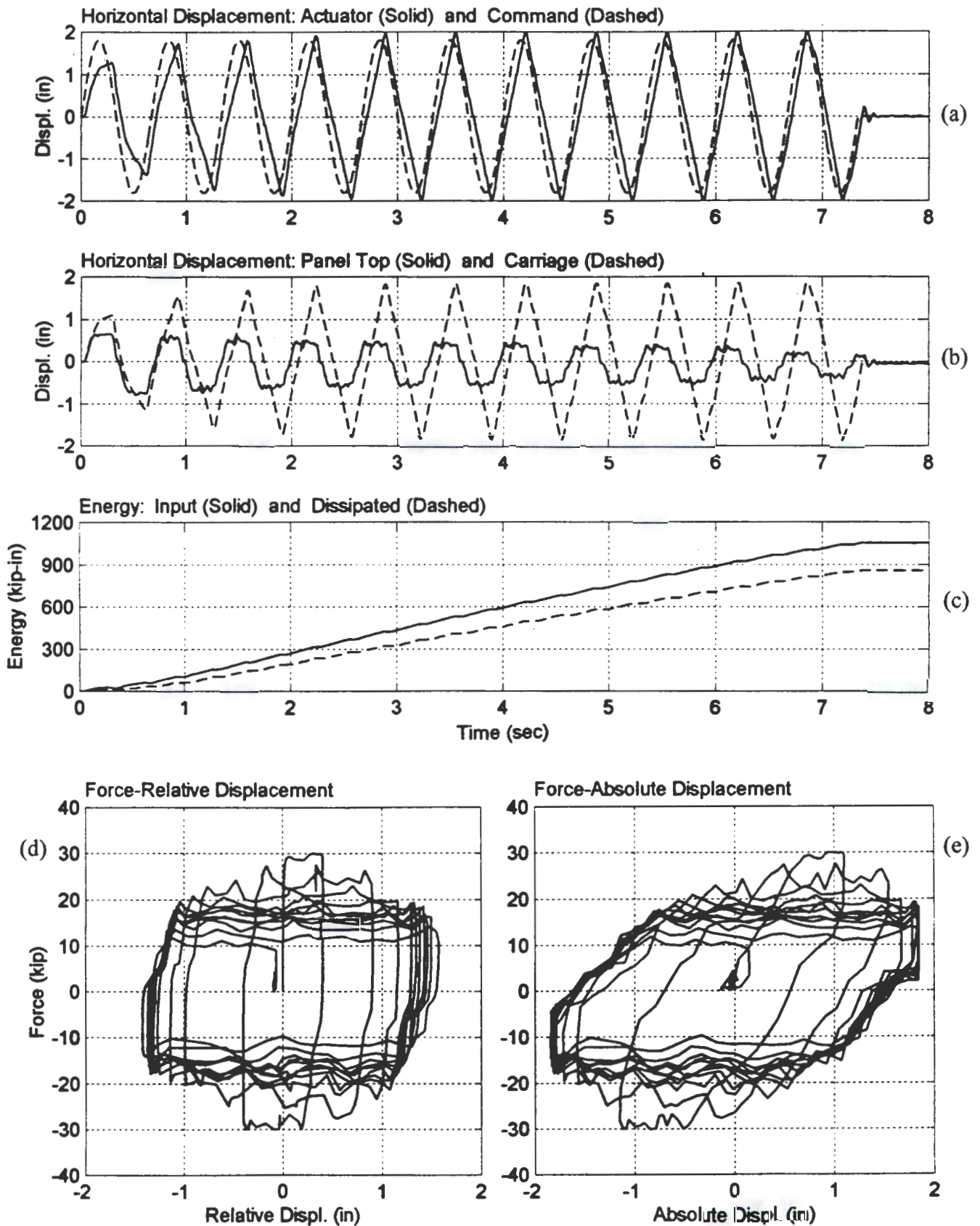

Figure 7.16 Test results

UCR Rivera Library--Test No. 23 Anchorage B Three Devices (T=200 ft-lbs)
Harmonic Motion (1.5 Hz, 1.8 in) File: 06271553.txt

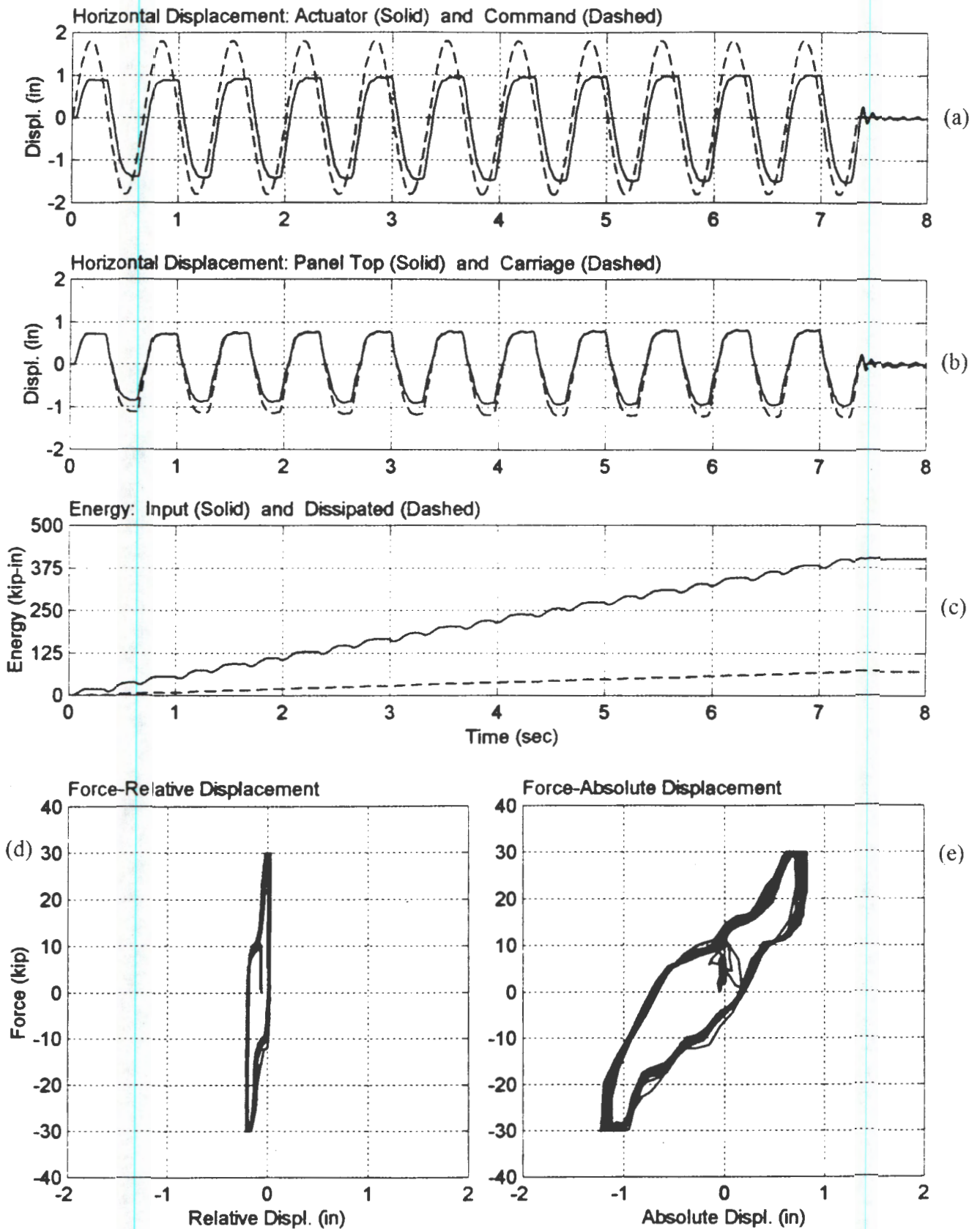

Figure 7.17 Test results

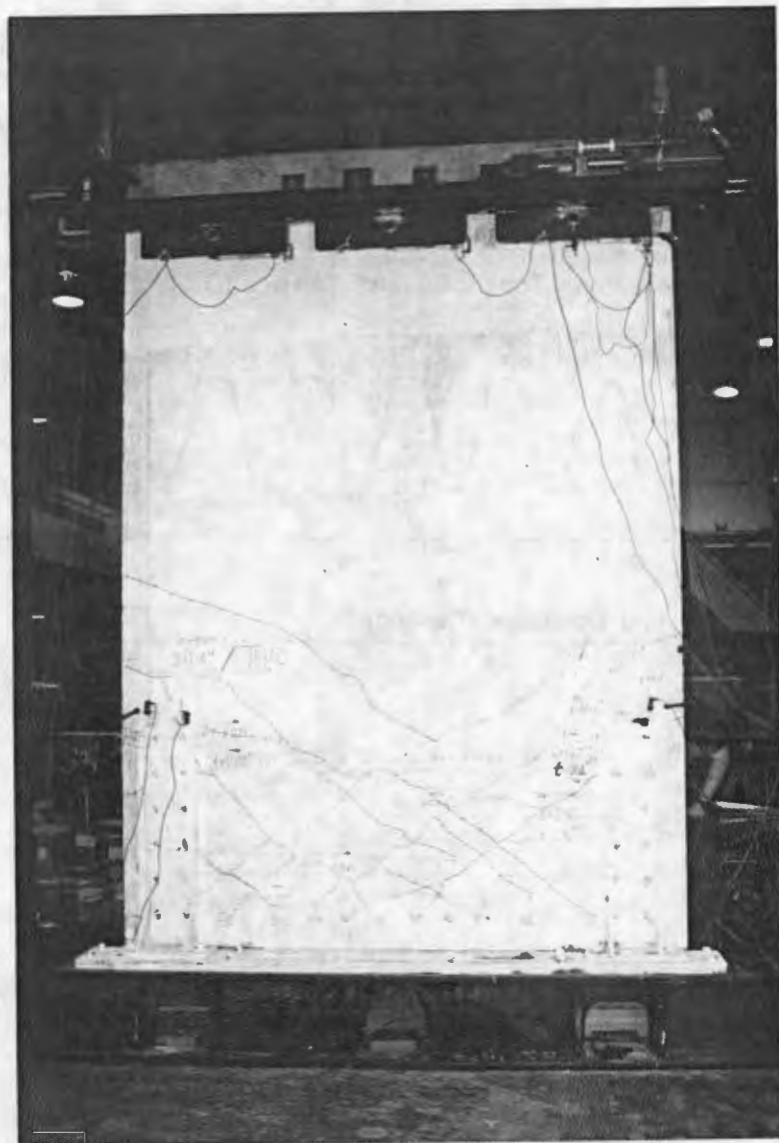

Figure 7.18. Cracked pattern after the last test

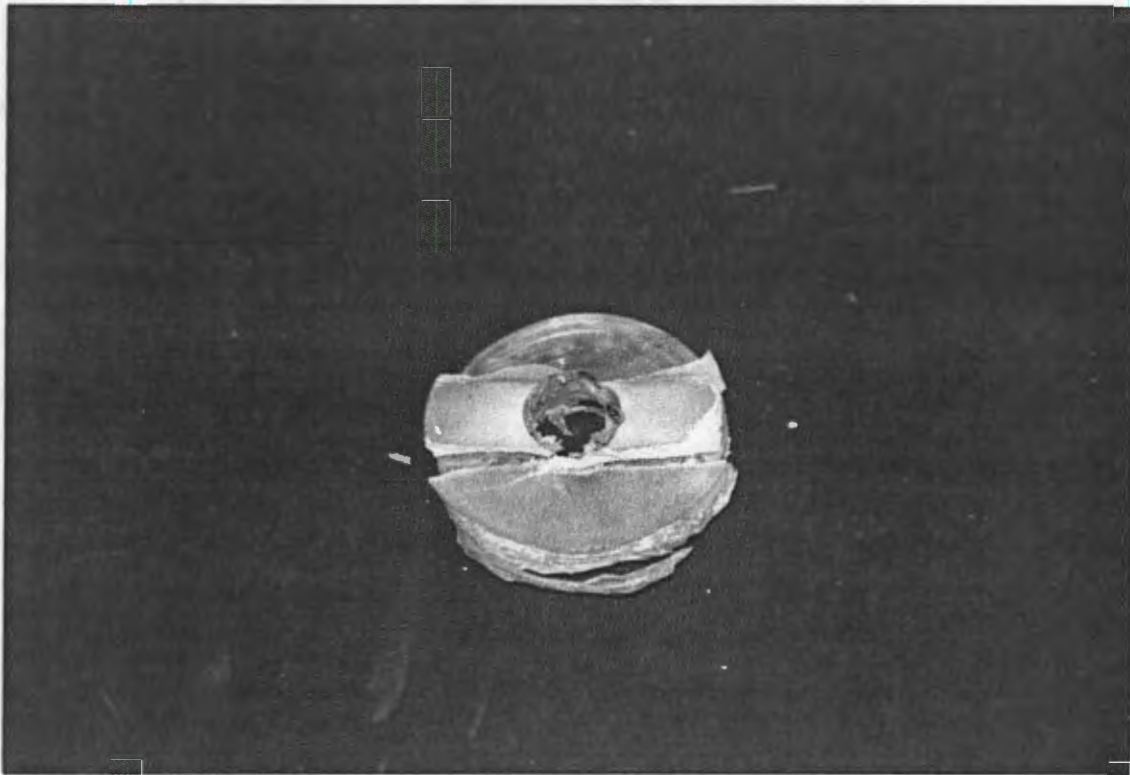

Figure 7.19. Brass washers after the last test

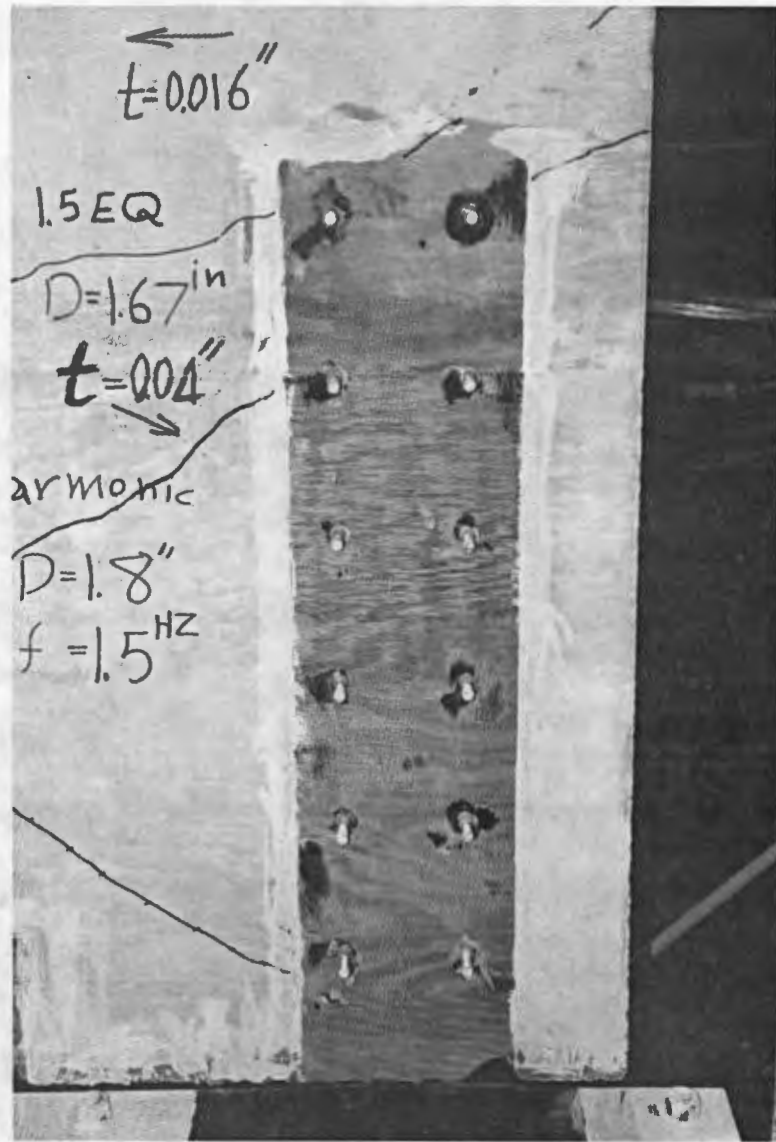

Figure 7.20 Studs after the last test



Figure 7.21. Close-up of the epoxy around the studs after the last test

8 CONCLUDING REMARKS

A full-scale model representative of the panels cladding the Rivera Library and the proposed retrofit system was built and tested under in-plane harmonic and seismic motion.

The proposed retrofit system, based on slotted bolted connections which dissipate energy through friction of sliding metal surfaces, showed stable and full hysteresis loops and the capacity to dissipate most of the energy delivered through the seismic motions.

Two anchoring systems, used to attach the panels to the structure, were studied. The epoxied bolted system provided adequate strength and stiffness to the base supports and minimized panel rocking during the simulated seismic shaking.

The coefficient of friction of the system seemed to depend on the configuration of the dissipators and the previous history of the motion. Although the sliding force depended mainly on the tension in the bolts, which can be controlled by applying the tightening torque with a calibrated wrench, the condition and quality of the sliding surfaces also seemed to have a significant effect on the response of the dissipators.

As mentioned before, the system was tested unidirectionally, while during real earthquakes the system will be shaken in all directions. The response of the retrofit system to severe out-of-plane, both transversal and torsional, and vertical motions should also be investigated.

The results of test with low amplitude motion, 0.5 in, showed that the energy dissipating devices at the top are dissipating only an insignificant amount of energy, therefore the system is not efficient under moderate types of earthquakes.

There is concern about the durability of the energy dissipators, especially regarding the possibility of electrolytic effects between the brass washers and the steel sections and galvanic corrosion subject to hostile environments. Accordingly, it is recommend that the brass washers be protected with a coat of paint and that the energy dissipators be randomly inspected carefully at least every three years.

REFERENCES

- [1] Grigorian, C. E., and Popov, E. P., "Energy Dissipation with Slotted Bolted Connections", Report No. UCB/EERC-94/02, University of California at Berkeley, February 1994.
- [2] "MATLAB - High-Performance Numeric Computation and Visualization Software", The MathWorks, Natick, Mass., February 1995

ACKNOWLEDGEMENTS

The authors wish to express their gratitude to the staff of the Department of Civil and Environmental Engineering. Doug Zulaica, Mark Troxler, Dick Parsons, and Jeff Higginbotham from the Machine Shop did an excellent job with the fabrication of the test setup, the lightweight concrete wall, and the energy dissipators. They were ably supervised by Larry Baker, who also helped with frame design and with materials purchasing. Ben Ellert and Chris Moy, from the Electronics Shop, configured and installed the data acquisition and control systems. Bill MacCracken and Dr. Shakhzod Takhirov helped videotaping some of the tests.

Brent Nuttall, of Nabih Youssef and Associates, was very helpful throughout the project with technical advice and suggestions regarding the implementation of their design. Nabih Youssef and Associates provided encouragement and the funds required for the second phase of the testing.

APPENDIX A

SUPPLEMENTARY TESTS:

CONCRETE PROPERTIES

AND

PRELIMINARY TESTS

OF DISSIPATOR COMPONENTS

AI CONCRETE PROPERTIES (MODEL PANEL)

A1.1 Mix Design

The panel was made of lightweight concrete. Mix design, proposed by the Sugar City Building Materials and approved by the UCB project team, is presented in the table below:

SUGAR CITY BUILDING MATERIALS

PROPOSED MIX DESIGN

All mix criteria per Sugar City Building Materials.

SUBJECT: U.C. BERKELEY

SC602814P 6.0 sks; 5/8" max.; LIGHTWEIGHT Ref # SP605-118-112
3000 psi @ 28 days; slump; W/C = 0.50

<u>SSD WEIGHTS</u>		<u>% USED</u>	<u>SP. GR.</u>	<u>ABS. VOL.</u>
480 LBS	CEMENT TYPE II		3.15	2.442
84 LBS	POZZOLAN, 15% REPL.		2.30	0.585
281 LBS	WATER, 34 GAL.		1.00	4.503
	AIR, 4%		-	1.080
860 LBS	BAYPOR F-43 5/8"	35.2	1.55	8.892
1337 LBS	RADUM TOP SAND	54.8	2.68	7.995
<u>245 LBS</u>	BLEND SAND	<u>10.0</u>	2.60	<u>1.510</u>
3287 LBS	TOTAL	100.0		27.007 CU FT

WRDA 64 @ 3 OZ/CWT
AEA @ 3/4 OZ/SK

THE WEIGHTS ARE IN POUNDS FOR ONE CUBIC YARD OF FRESH CONCRETE. AGGREGATE AND WATER WEIGHTS ARE FOR MATERIALS IN SATURATED, SURFACE-DRY CONDITION AND MUST BE ADJUSTED FOR MOISTURE AT THE TIME OF BATCHING.

Mixes intended for pump placement should be reviewed by the pumping contractor prior to use to confirm compatibility of equipment with jobsite conditions.

A1.2 Measured Properties Of Concrete

The concrete was placed in a wooden form on April 16, 1997.

The unit weight of the freshly mixed concrete was 121 lb/cuft (determined in accordance with ASTM Test Method C138).

Measured slump was 4" (as to C143).

Standard 6"x12" test cylinders were made and cured following ASTM C31 requirements. Specimens were tested on May 14, 1997 in accordance with ASTM C39 and C469.

The average compressive strength was 4200 psi. The average chord modulus of elasticity was 2.20×10^6 psi. Stress-strain curves are presented below:

Concrete Testing: Stress vs. Strain

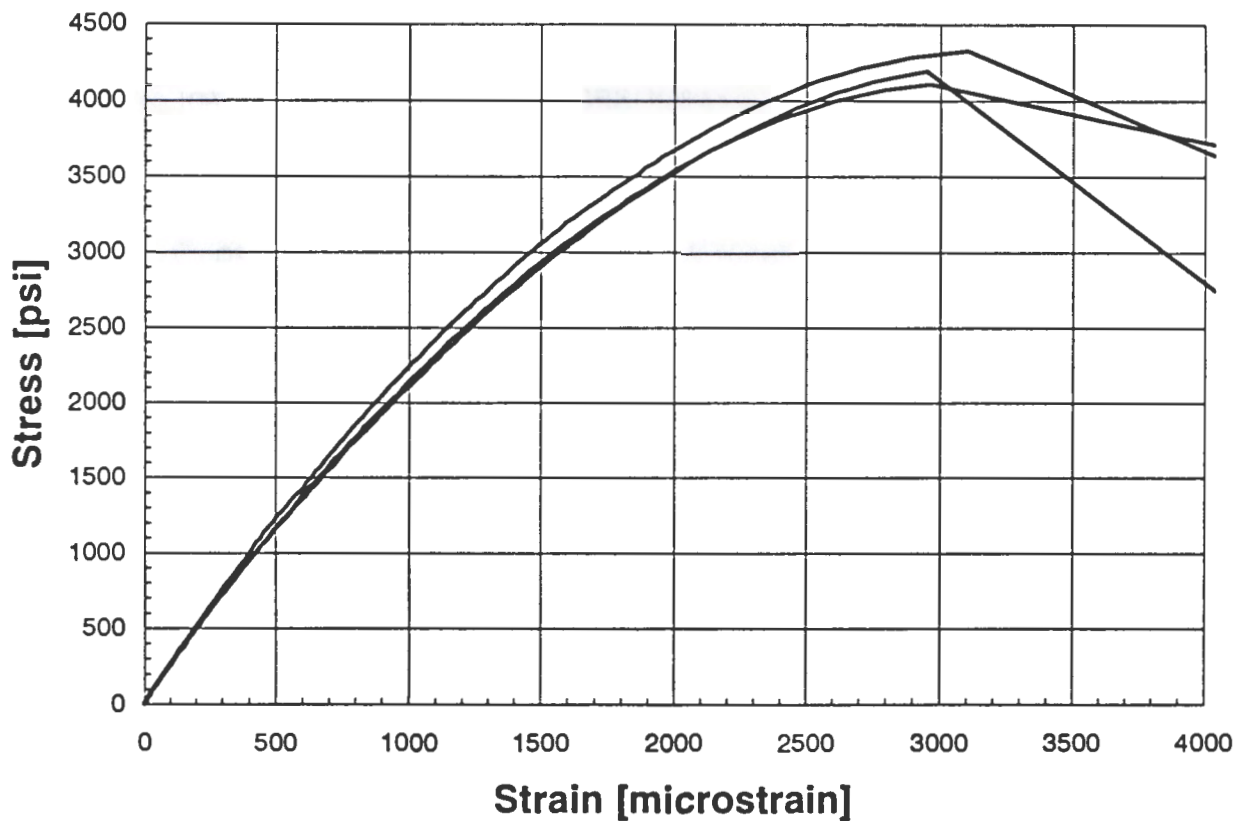

A2 BELLEVILLE WASHERS

A2.1 Dimensions

To maintain a constant force throughout dimensional changes from wear, Belleville washers were used in all friction connections. They are circular disk springs formed to a conical shape. The performance of the springs depend on their dimensions (Figure A2.1):

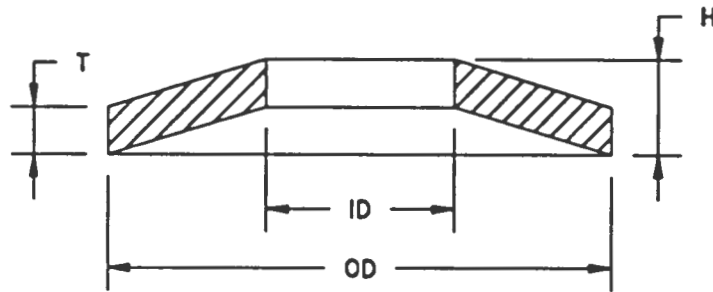

Figure A2.1 Belleville Washer.

Initially three sizes of the washers were selected (see the table below):

High Carbon Alloy Material -- AISI 6150 Alloy (ASTM A506)

	Bolt Size 3/4"		
Part Number	12L112	12H150	12EH168
Outside Diameter [in]	1.5	1.75	2.25
Inside Diameter [in]	0.773	0.773	0.773
Thickness [in]	0.115	0.134	0.172
Overall Height [in]	0.148	0.207	0.234
Deflection [in]	0.033	0.053	0.062
Load [lb]	6,000	12,000	15,000

A2.1 Calibration

The setup for a calibration of the Belleville washers is shown in Figure A2.2. Calibration was performed in 120 kips universal testing machine. Applied load was measured by the machine load cell and by a load washer. Deflection of the Belleville washer was measured by two LVDTs.

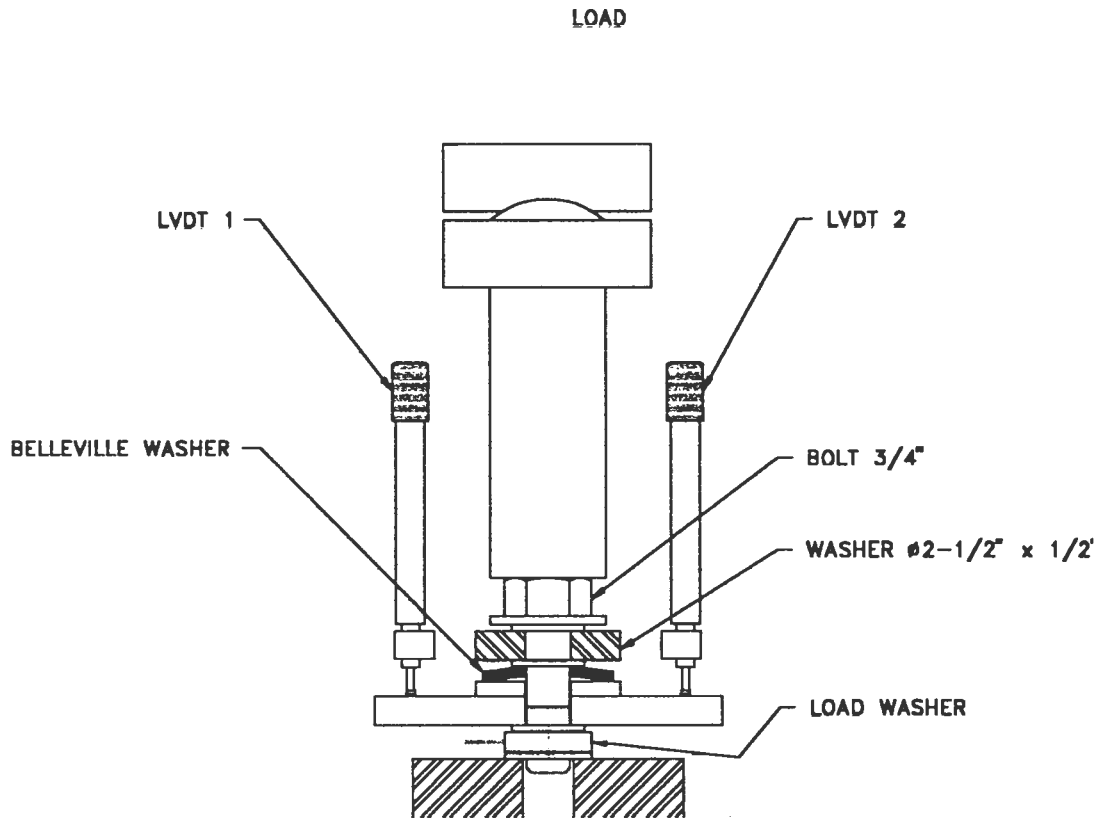

Figure A2.2 Belleville Washer Calibration

Load - Displacement curves for single washers are presented in Figure A2.3. For each washer size three first loading-unloading cycles are shown. The maximum load applied in each cycle was equal to 20 kips. The displacement during the first loading was larger than for the second and subsequent loading. After third cycle the washers could be considered as being seated in and for all following cycles curves were very close to the third one. The unloading curves were below the loading curves. All washers had the average stiffness about 220 kips/inch on the loading path and about 180 kips/inch on the unloading path. The loads required to flatten the washers were close to specified by the manufacture (Solon Manufacturing Company).

Stacking washers in parallel increases stiffness of the stack. Figure A2.4 shows the load - displacement curve for a stack of two 12EH168 Solon Belleville washers. The stack of two washers had approximately double stiffness and double force was required to flatten the stack in comparison with the single washer.

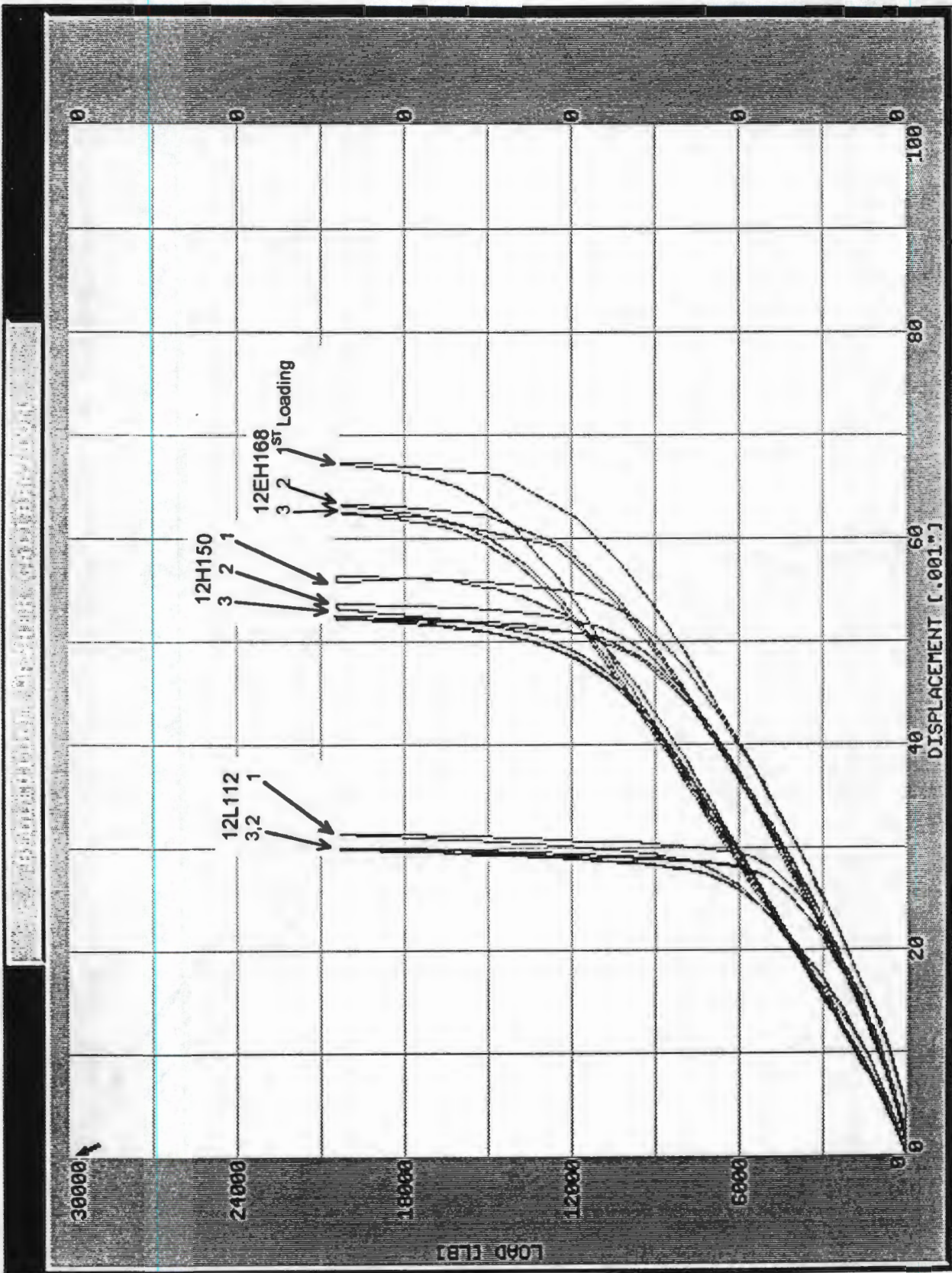

Figure A2.3 Load - Displacement Curves for Single Belleville Washers

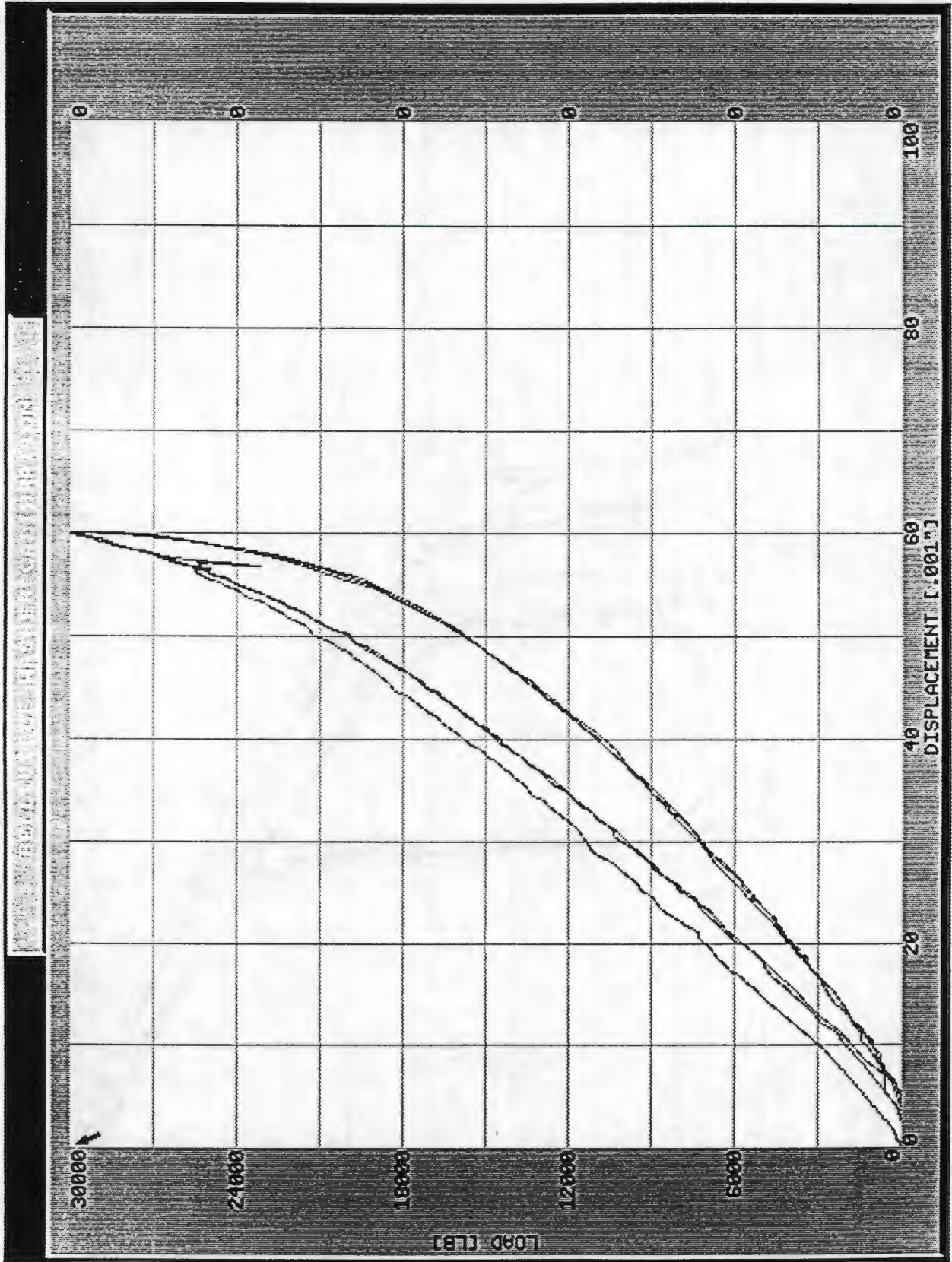

Figure A2.4 Load - Displacement Curve for Two 12EH168 Belleville Washers

A3 BOLT TENSION VS. APPLIED TORQUE

To get the relation between the applied torque and corresponding bolt tension an assemblage modeling the real friction connection was fabricated. The assemblage is shown in Figure A3.1. That assemblage then was installed in torsion testing machine as it is shown in Figure A3.2.

The torque was measured by the machine indicator and the bolt tension by the load washer. The obtained relationship between the applied torque and bolt tension is shown in Figure A3.3.

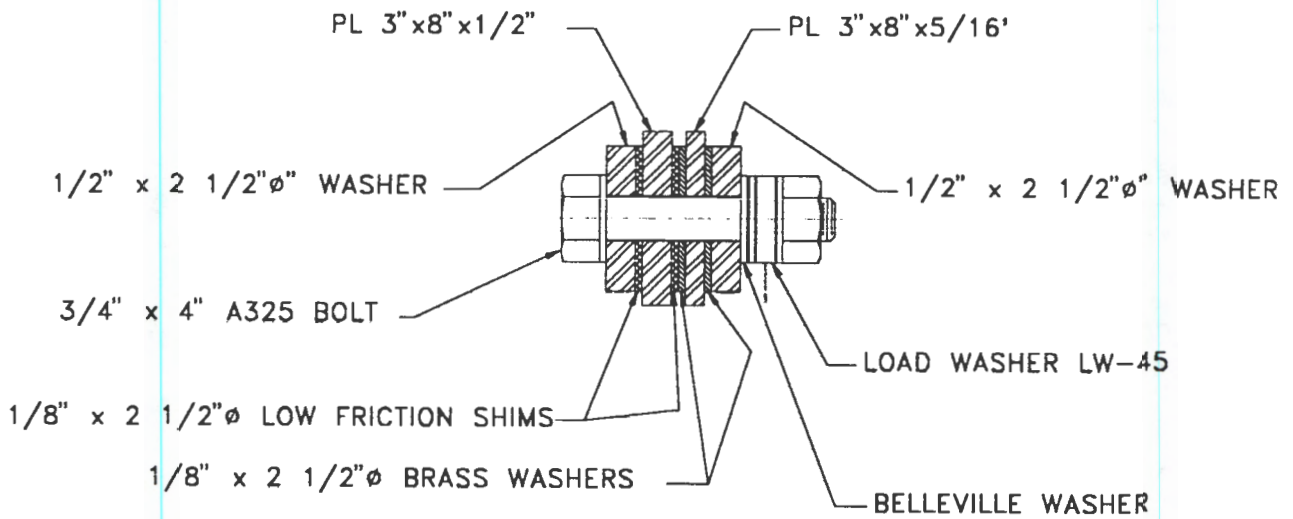

Figure A3.1

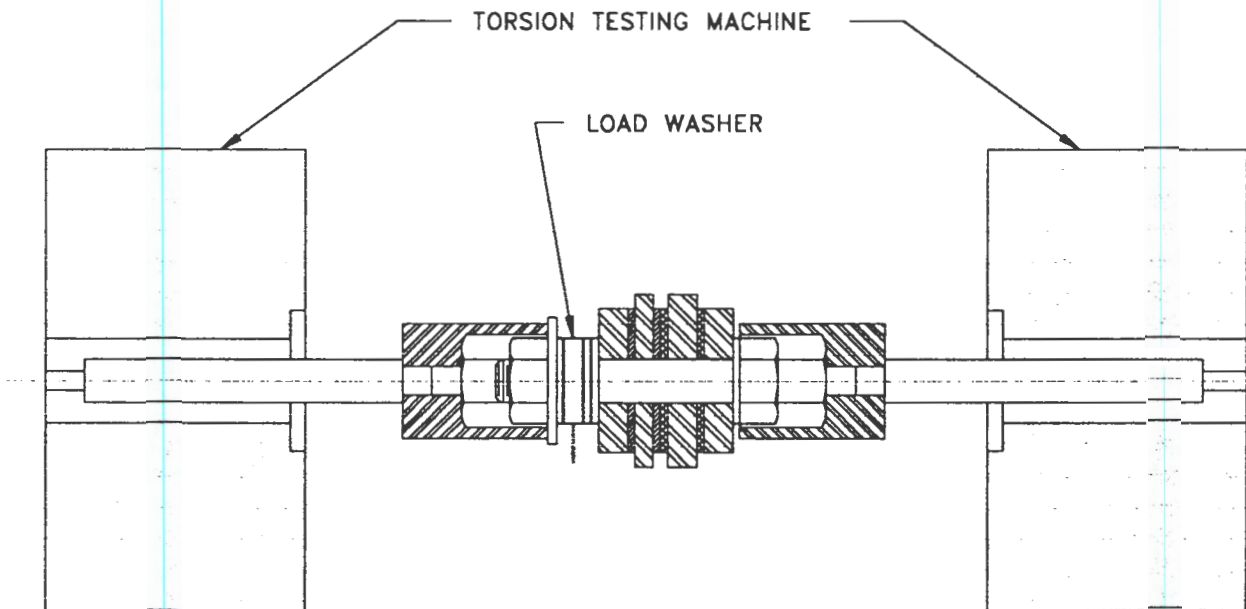

Figure A3.2

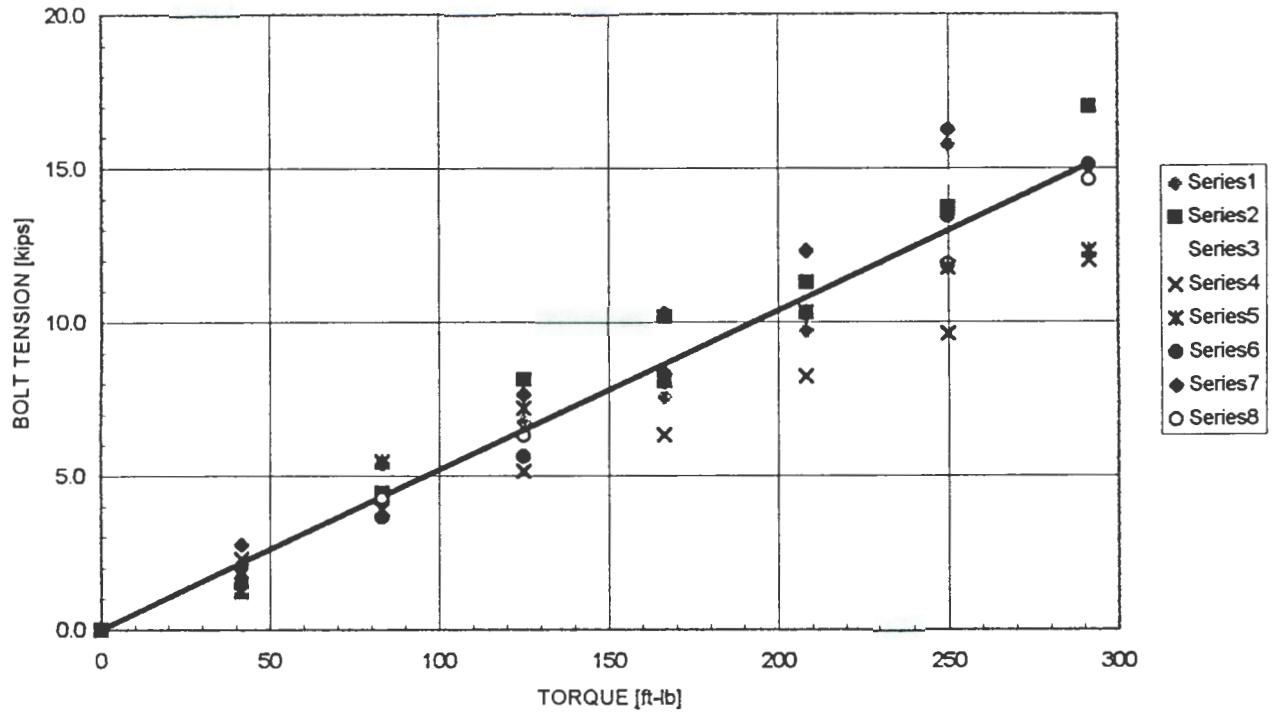

Figure A3.3 Bolt Tension vs. Applied Torque.

A4 FRICTION IN STEEL-BRASS CONNECTION

A simple test assemblage shown in Figure A4.1 was constructed to estimate roughly the coefficient of friction in the connection. The assemblage was tested in a UTM testing machine and load-displacement diagrams were obtained for several of values of bolt tension. The friction force was measured by the machine load cell, the bolt tension by a load washer, and the displacement of the UTM head by a linear potentiometer.

The diagrams obtained are presented in Figure A4.2.

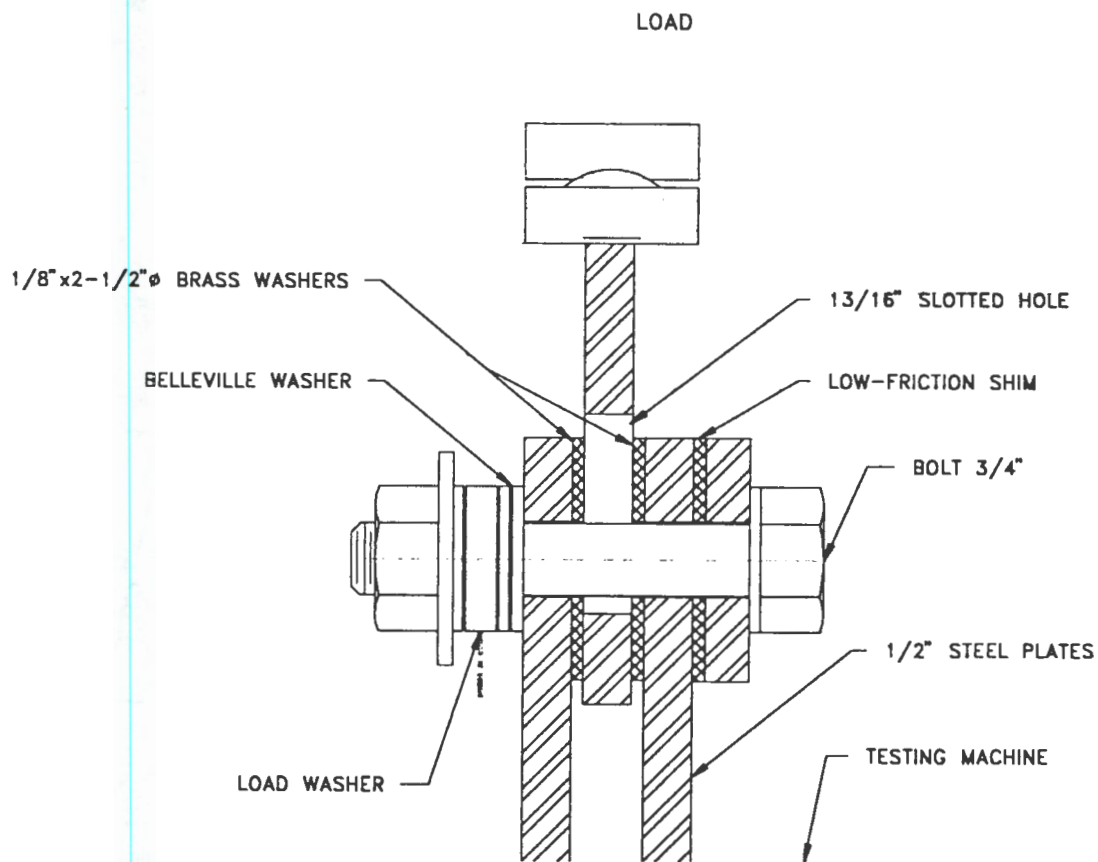

Figure A4.1 Test Setup for Friction Estimation.

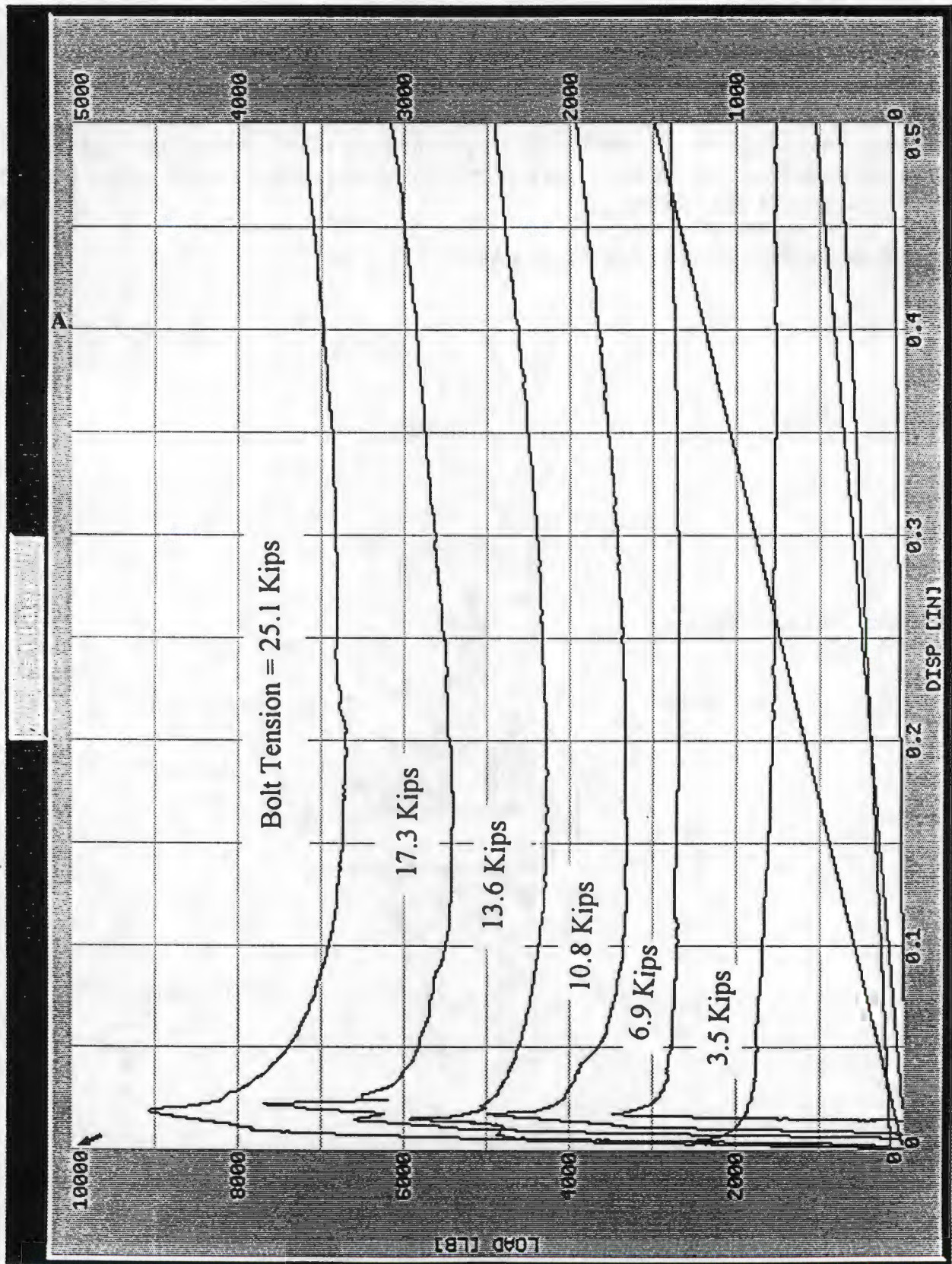

Figure A4.2 Friction Force - Displacement Diagrams for Different Levels of Bolt Tension.

APPENDIX B

TEST RESULTS

TESTING PROGRAM

Test #	Date	No. of Devices	Signal Type	Freq (Hz)	Ampl (in)	Torq (ft-lbs)	Washers	Anchorage Type ^(1,2)	File Name ⁽³⁾
1	05/22/97	1	Harmonic	0.1	2.0	0	Unpainted	A	05221001.txt
2	//	1	Harmonic	0.2	1.8	200	Unpainted	A	05221031.txt
3	//	1	Harmonic	0.2	1.8	100	Unpainted	A	05221403.txt
4	//	1	Harmonic	0.5	1.8	100	Unpainted	A	05221405.txt
5	//	1	Harmonic	0.5	1.8	100	Unpainted	A	05221433.txt
6	//	1	Harmonic	1.0	1.8	100	Unpainted	A	05221445.txt
7	//	1	Harmonic	1.5	1.8	100	Unpainted	A	05221454.txt
8	06/04/97	3	Harmonic	0.05	1.8	100	Painted	A	06041203.txt
9	//	3	Harmonic	0.05	1.8	150	Painted	A	06041214.txt
10	06/10/97	3	Harmonic	0.05	1.8	100	Painted	A	06101049.txt
11	//	3	Seismic	--	1.1	100	Painted	A	06101117.txt
12	//	3	1.5 * Seismic	--	1.65	100	Painted	A	06101134.txt
13	//	3	Harmonic	1.5	1.8	100	Painted	A	06101148.txt
14	06/27/97	3	Harmonic	0.05	1.8	50	Painted	B	06271234.txt
15	//	3	Harmonic	0.05	1.8	100	Painted	B	06271255.txt
16	//	3	Seismic	--	1.1	100	Painted	B	06271329.txt
17	//	3	1.5 * Seismic	--	1.65	100	Painted	B	06271349.txt
18	//	3	Harmonic	1.5	1.8	100	Painted	B	06271410.txt
19	//	3	Harmonic	1.5	0.5	100	Painted	B	06271435.txt
20	//	3	Harmonic	1.5	1.8	100	Painted	B	06271440.txt
21	//	3	Harmonic	1.5	1.8	100	Painted	B	06271509.txt
22	//	3	Harmonic	1.5	1.8	150	Painted	B	06271531.txt
23	//	3	Harmonic	1.5	1.8	200	Painted	B	06271553.txt

¹A = HITI KWIK

²B = HILTI HIT HY-150 (Epoxyed)

³mmdthmm.txt

UCR Rivera Library--Test No. 1 Anchorage A One Device (T=0 ft-lbs)
Harmonic Motion (0.1 Hz, 2 in) File: 05221001.txt

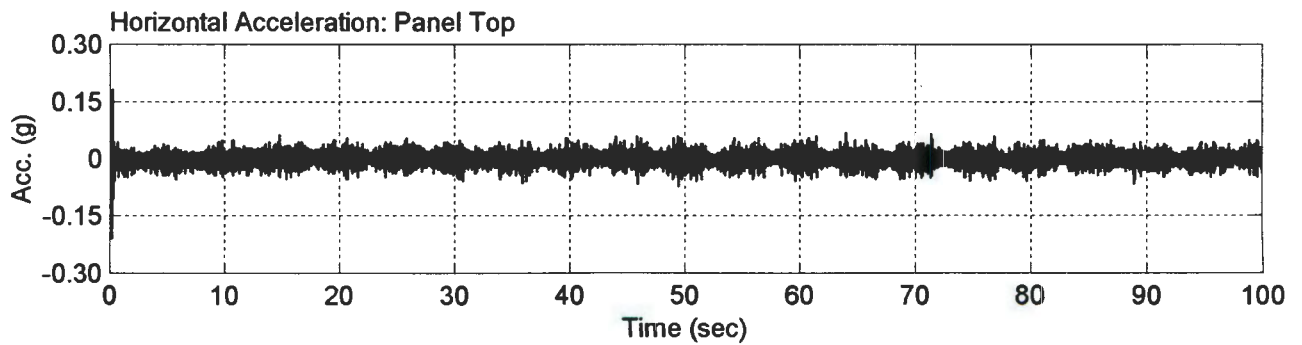
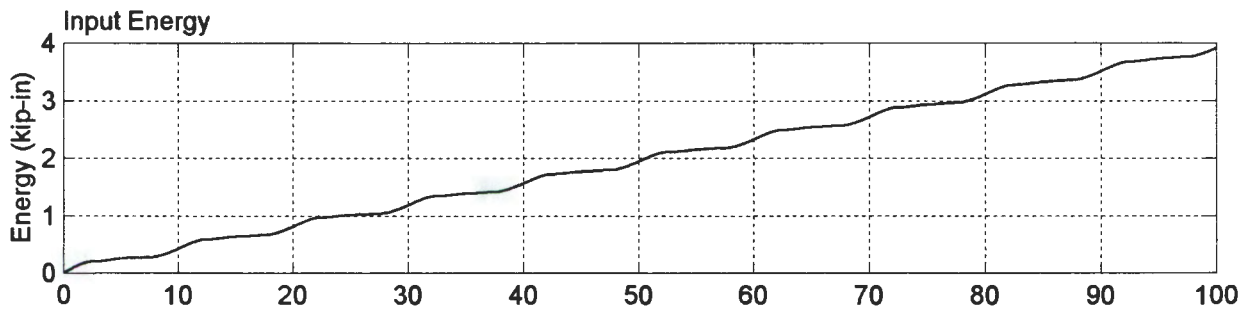
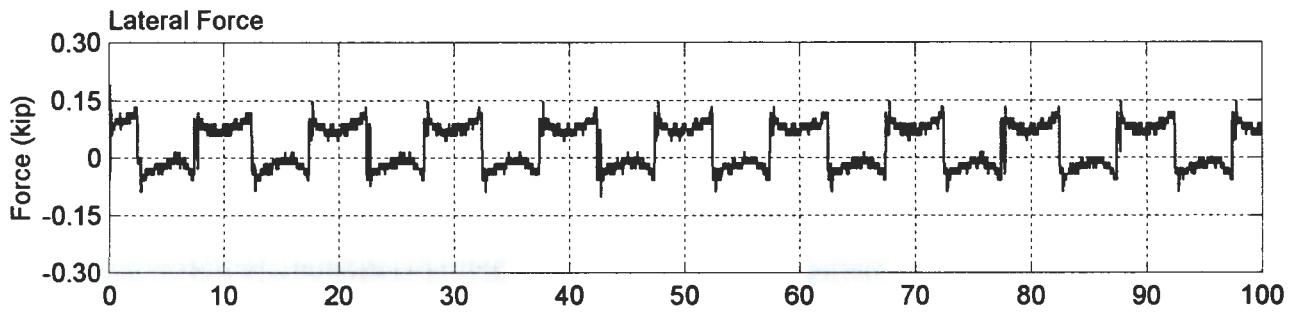
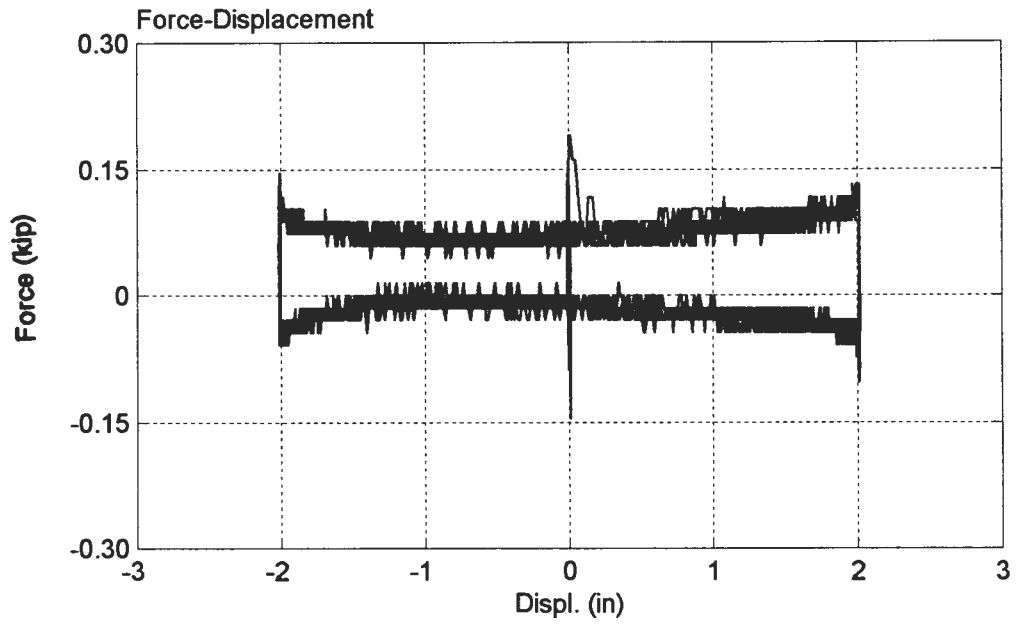

UCR Rivera Library--Test No. 2 Anchorage A One Device (T=200 ft-lbs)
Harmonic Motion (0.2 Hz, 1.8 in) File: 05221031.txt

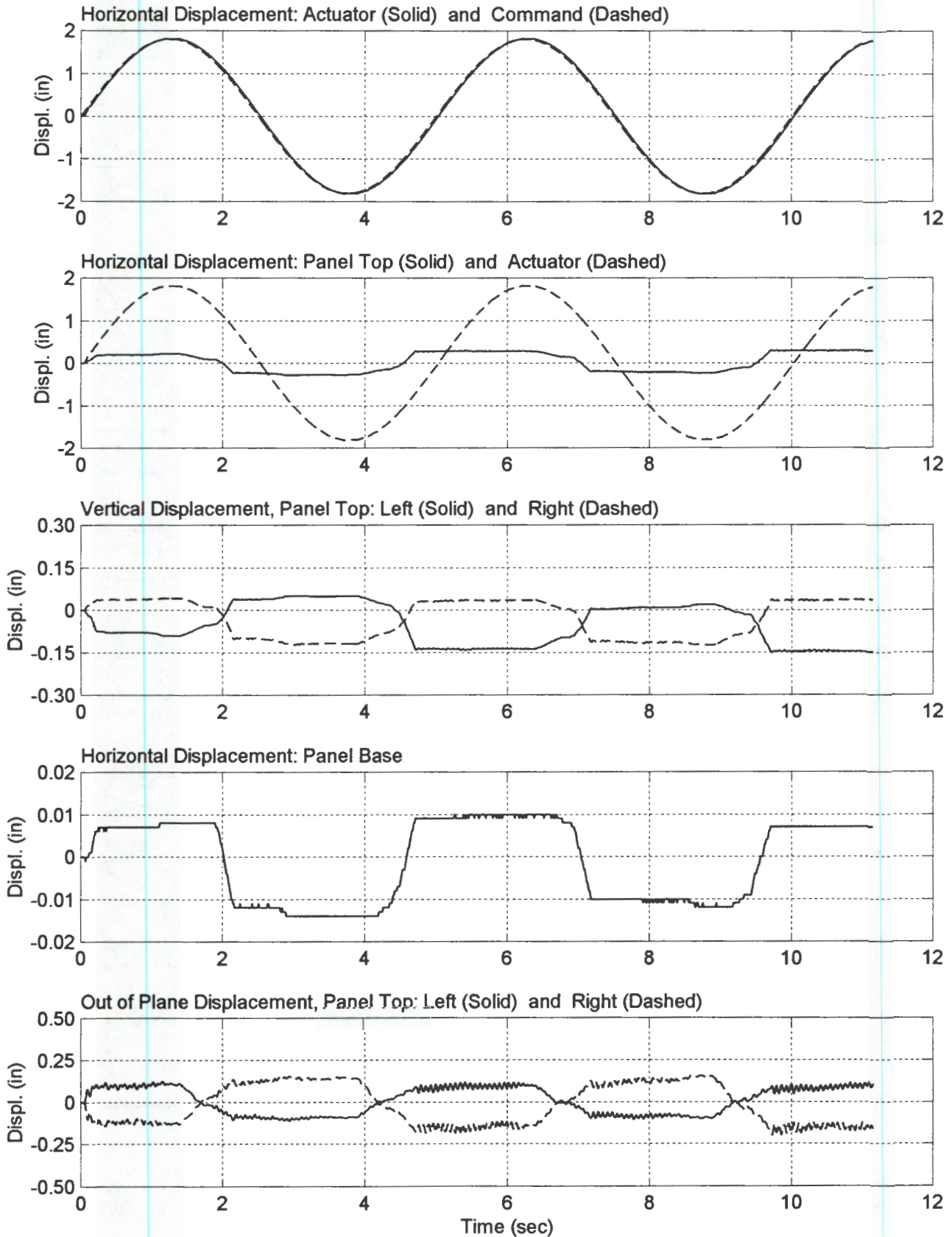

UCR Rivera Library--Test No. 2 Anchorage A One Device (T=200 ft-lbs)
Harmonic Motion (0.2 Hz, 1.8 in) File: 05221031.txt

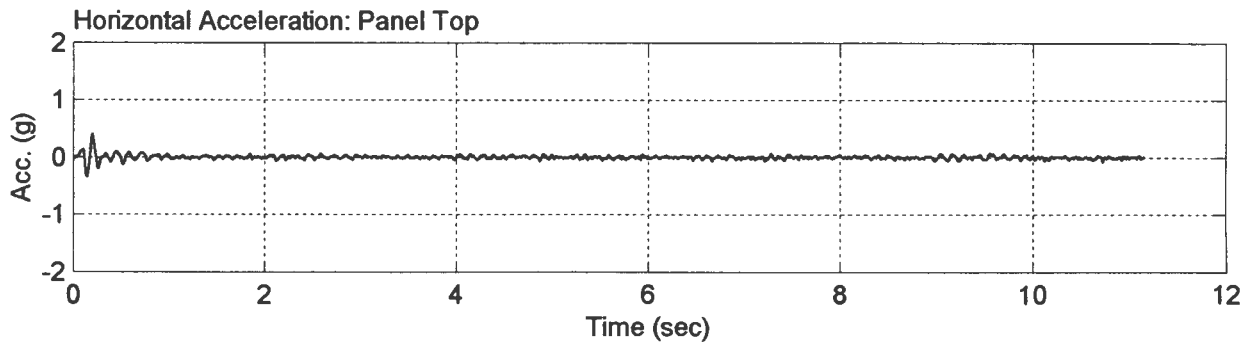
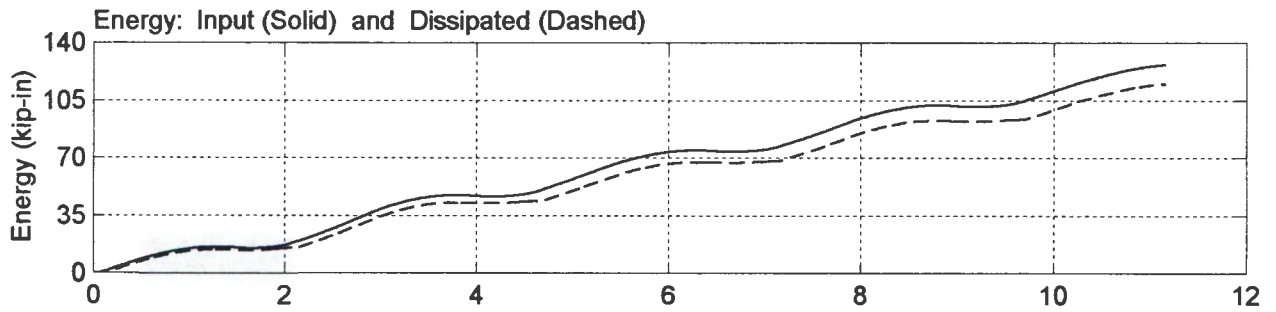
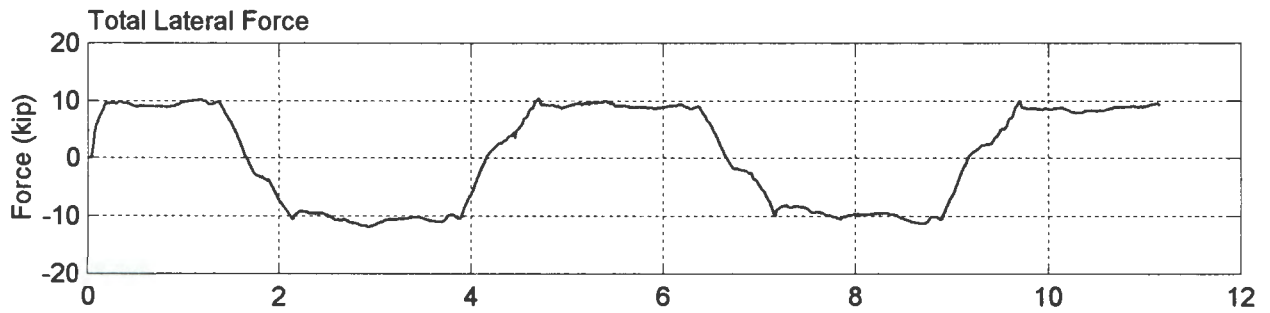
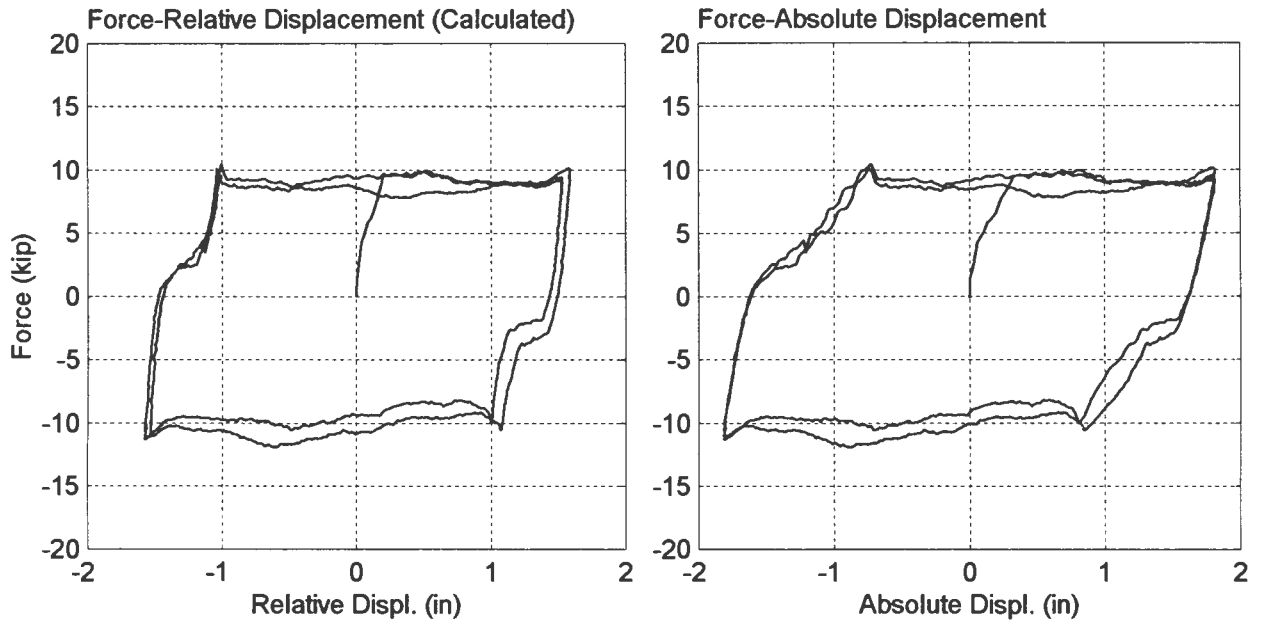

UCR Rivera Library--Test No. 3 Anchorage A One Device (T=100 ft-lbs)
Harmonic Motion (0.2 Hz, 1.8 in) File: 05221403.txt

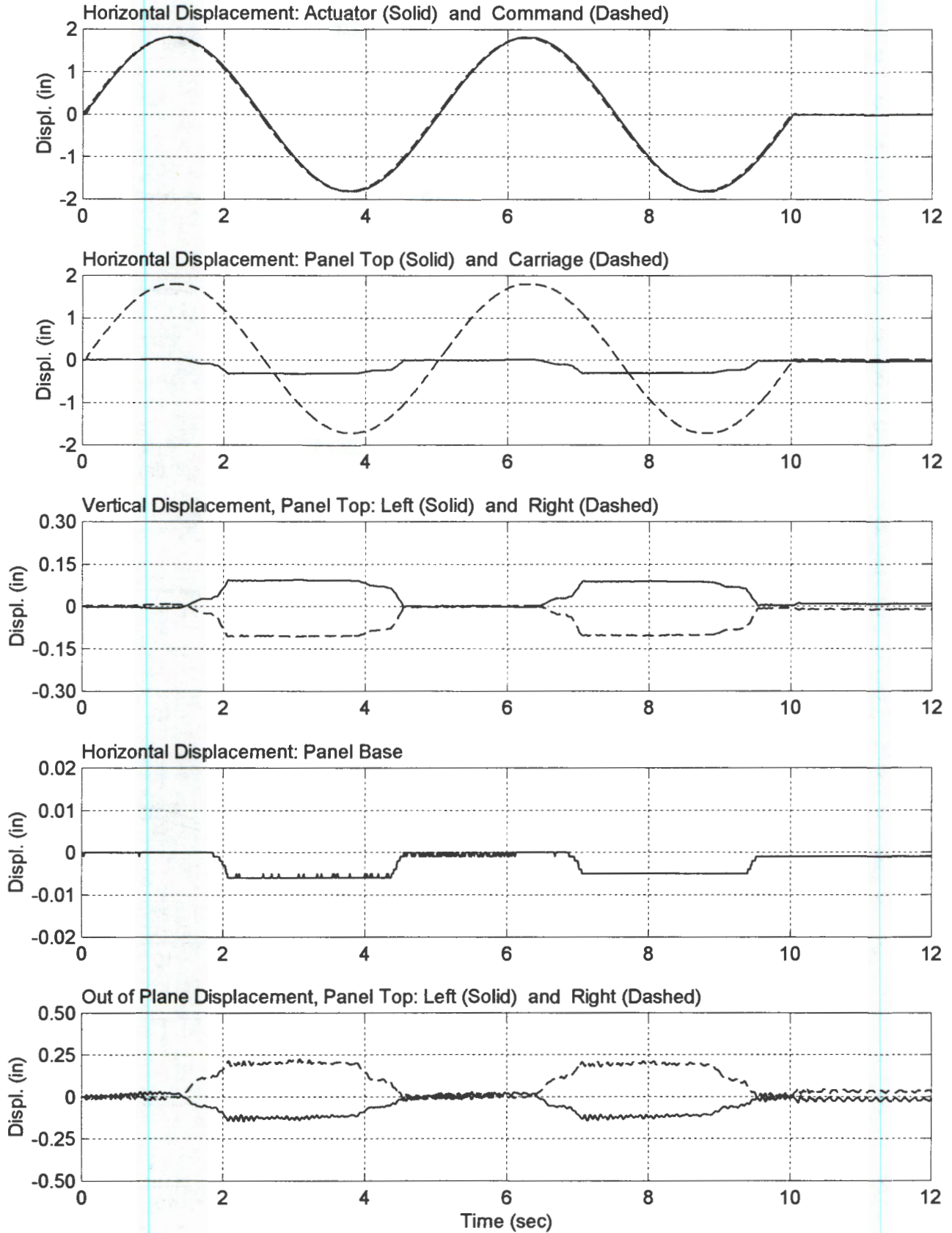

UCR Rivera Library--Test No. 3 Anchorage A One Device (T=100 ft-lbs)
Harmonic Motion (0.2 Hz, 1.8 in) File: 05221403.txt

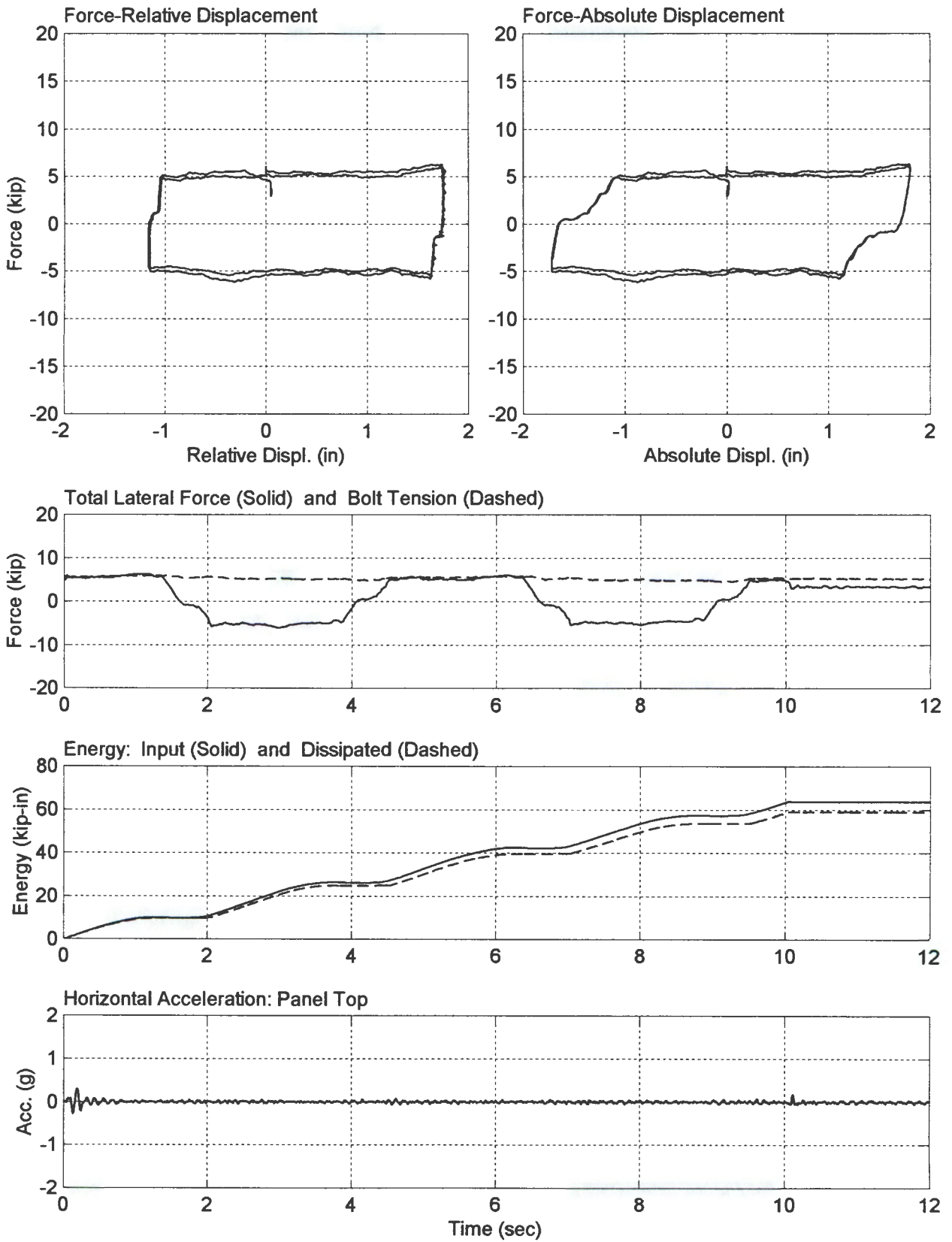

UCR Rivera Library--Test No. 4 Anchorage A One Device (T=100 ft-lbs)
Harmonic Motion (0.5 Hz, 1.8 in) File: 05221405.txt

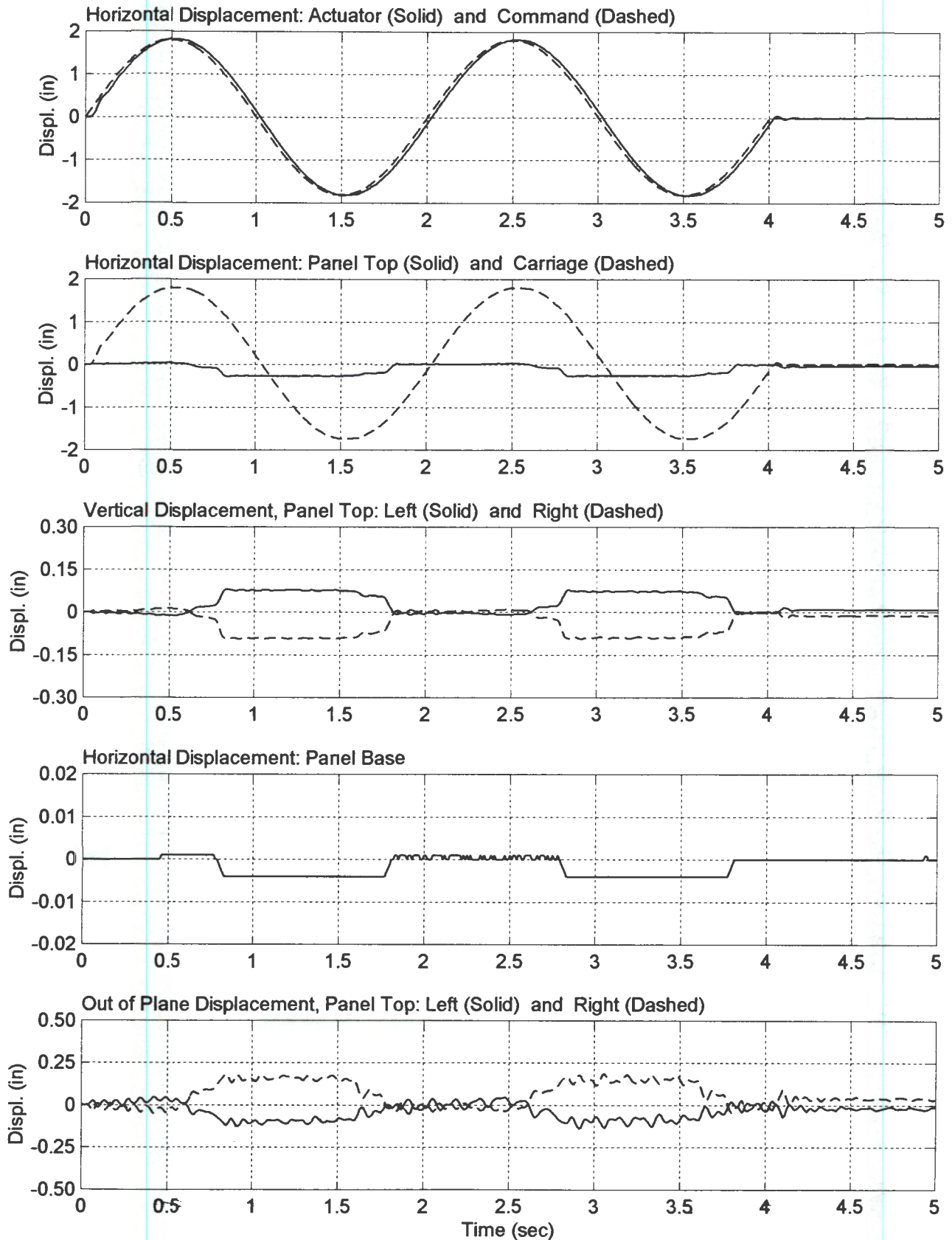

UCR Rivera Library--Test No. 4 Anchorage A One Device (T=100 ft-lbs)
Harmonic Motion (0.5 Hz, 1.8 in) File: 05221405.txt

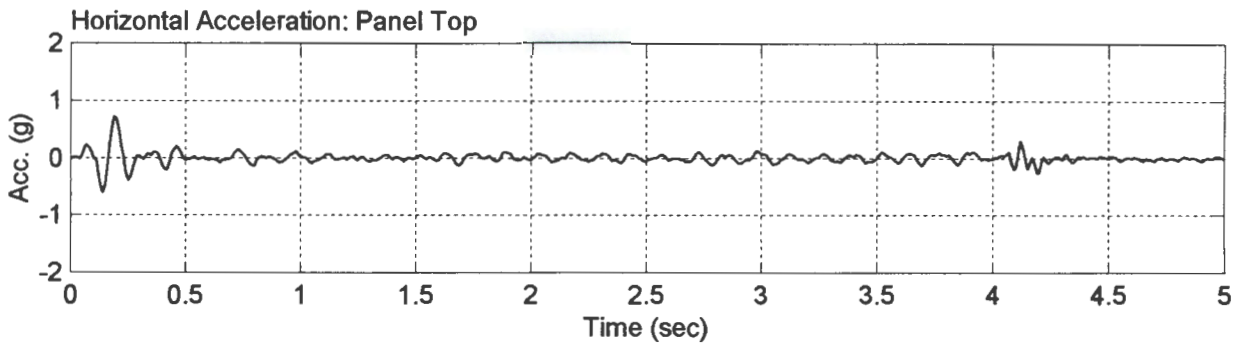
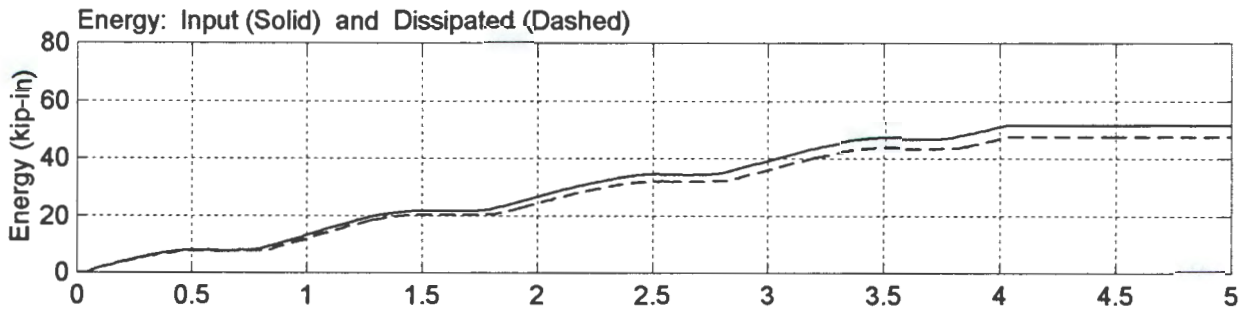
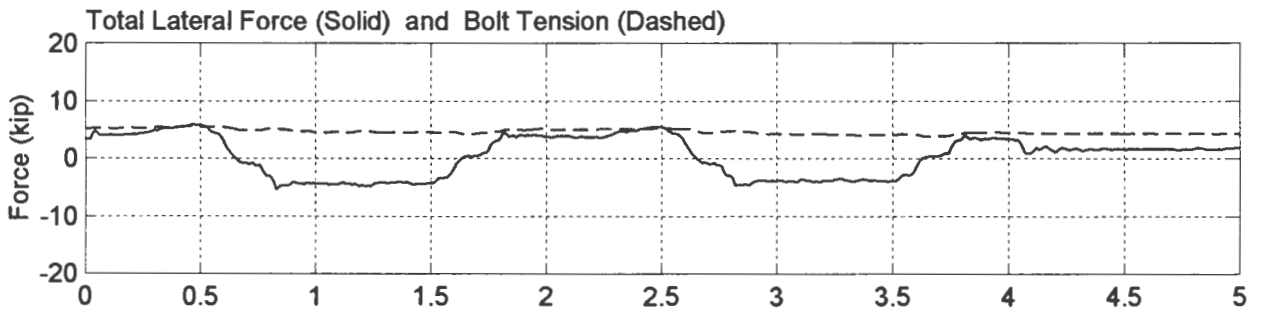
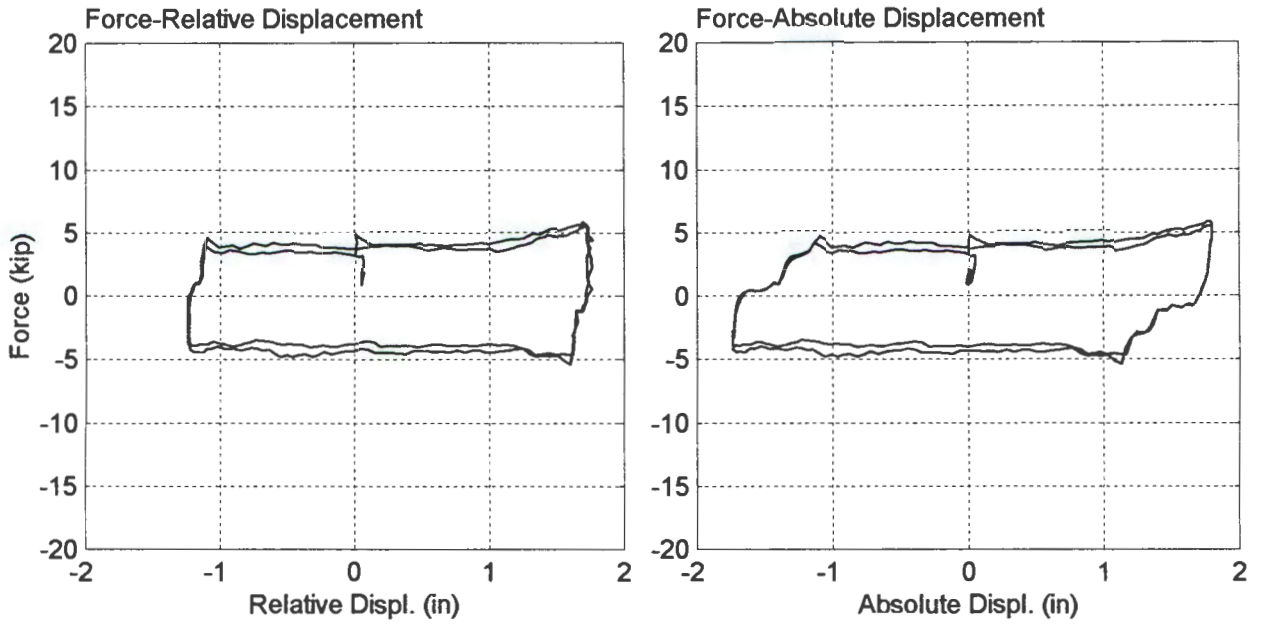

UCR Rivera Library--Test No. 5 Anchorage A One Device (T=100 ft-lbs)
Harmonic Motion (0.5 Hz, 1.8 in) File: 05221433.txt

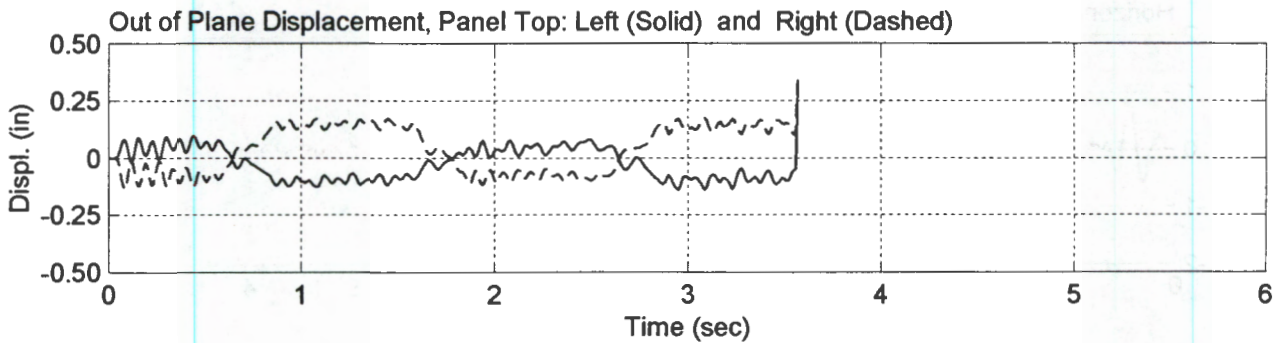
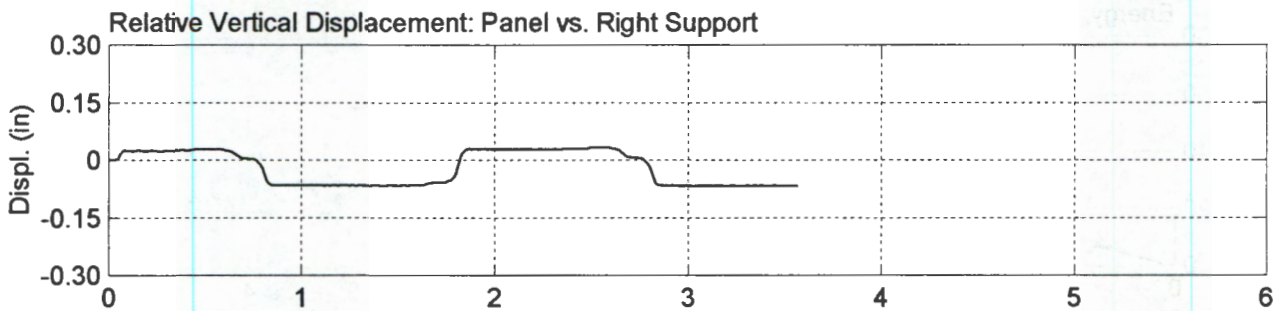
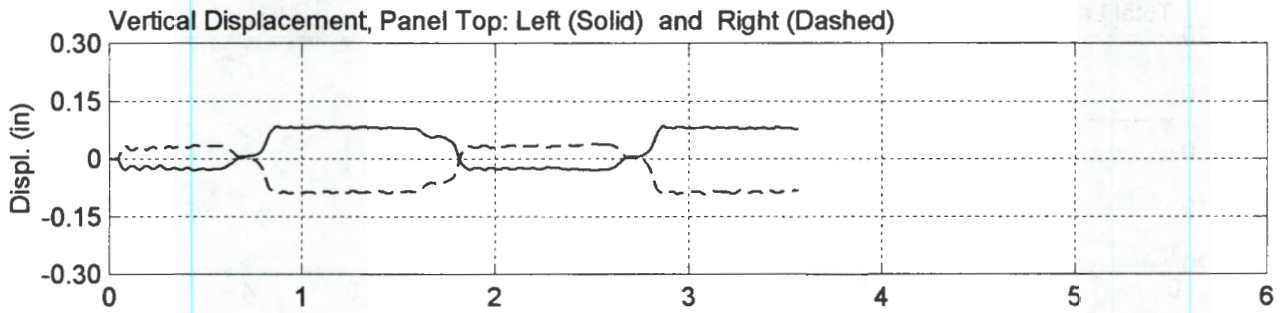
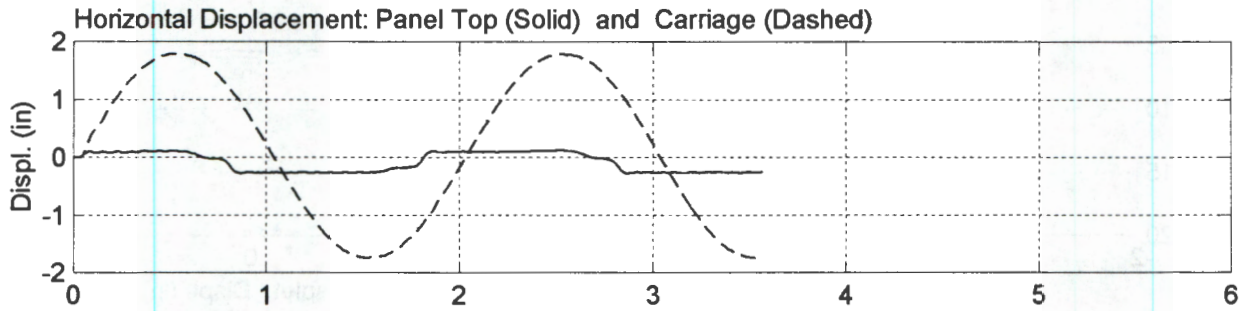
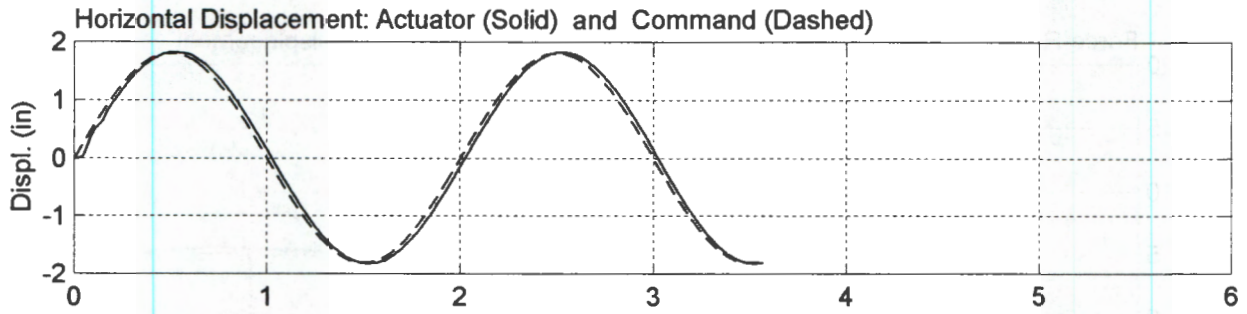

UCR Rivera Library--Test No. 5 Anchorage A One Device (T=100 ft-lbs)
Harmonic Motion (0.5 Hz, 1.8 in) File: 05221433.txt

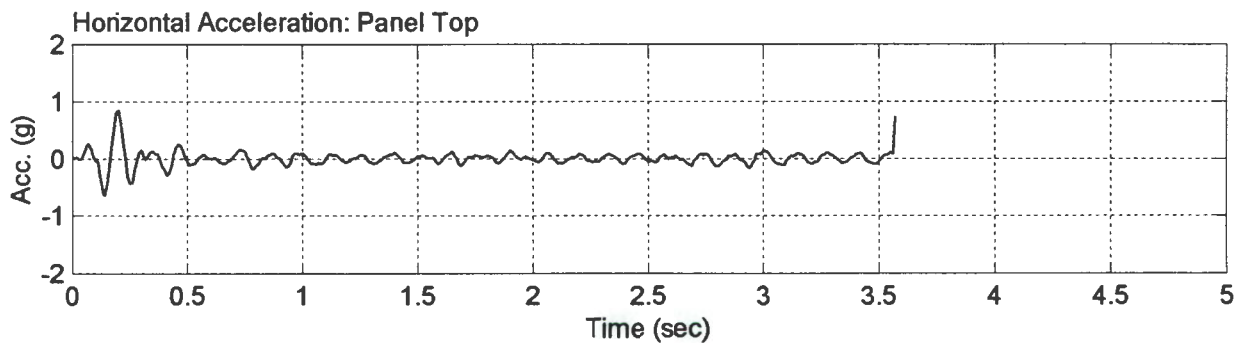
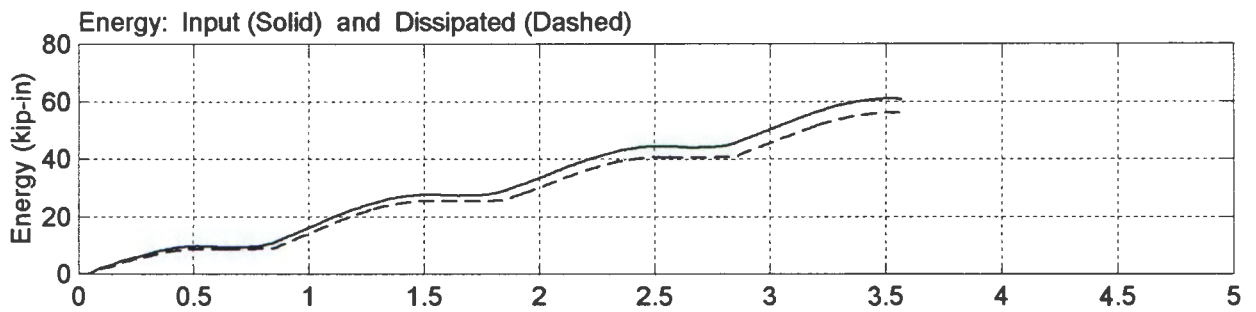
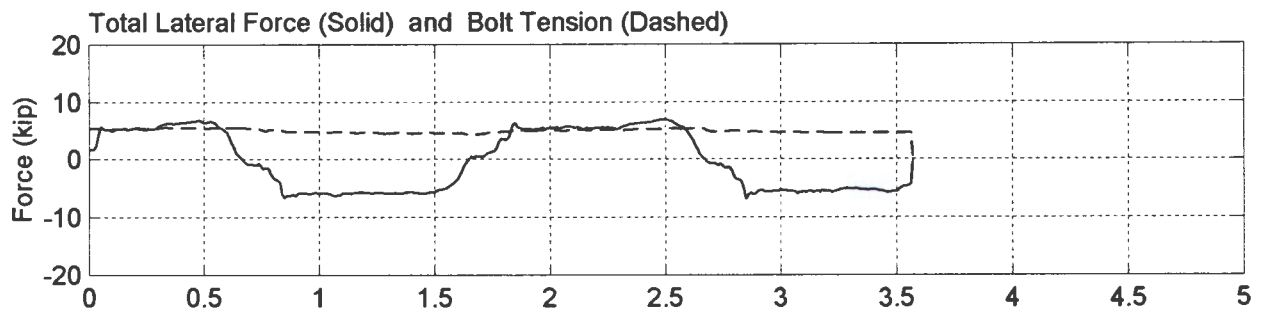
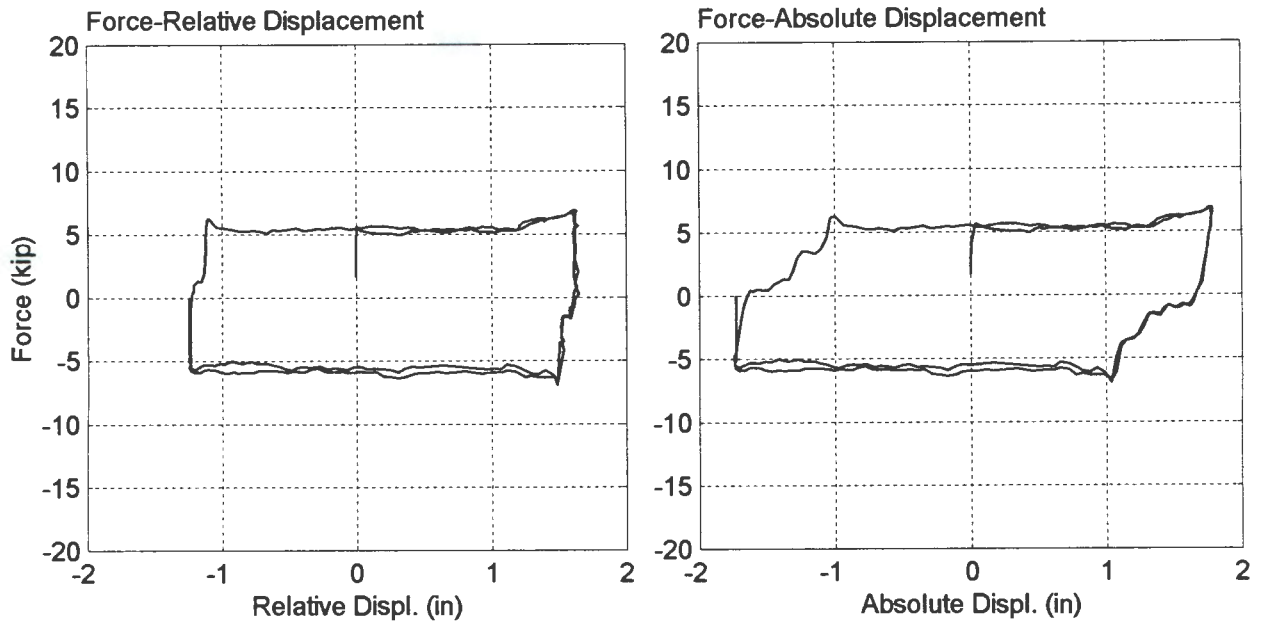

UCR Rivera Library--Test No. 6 Anchorage A One Device (T=100 ft-lbs)
Harmonic Motion (1 Hz, 1.8 in) File: 05221445.txt

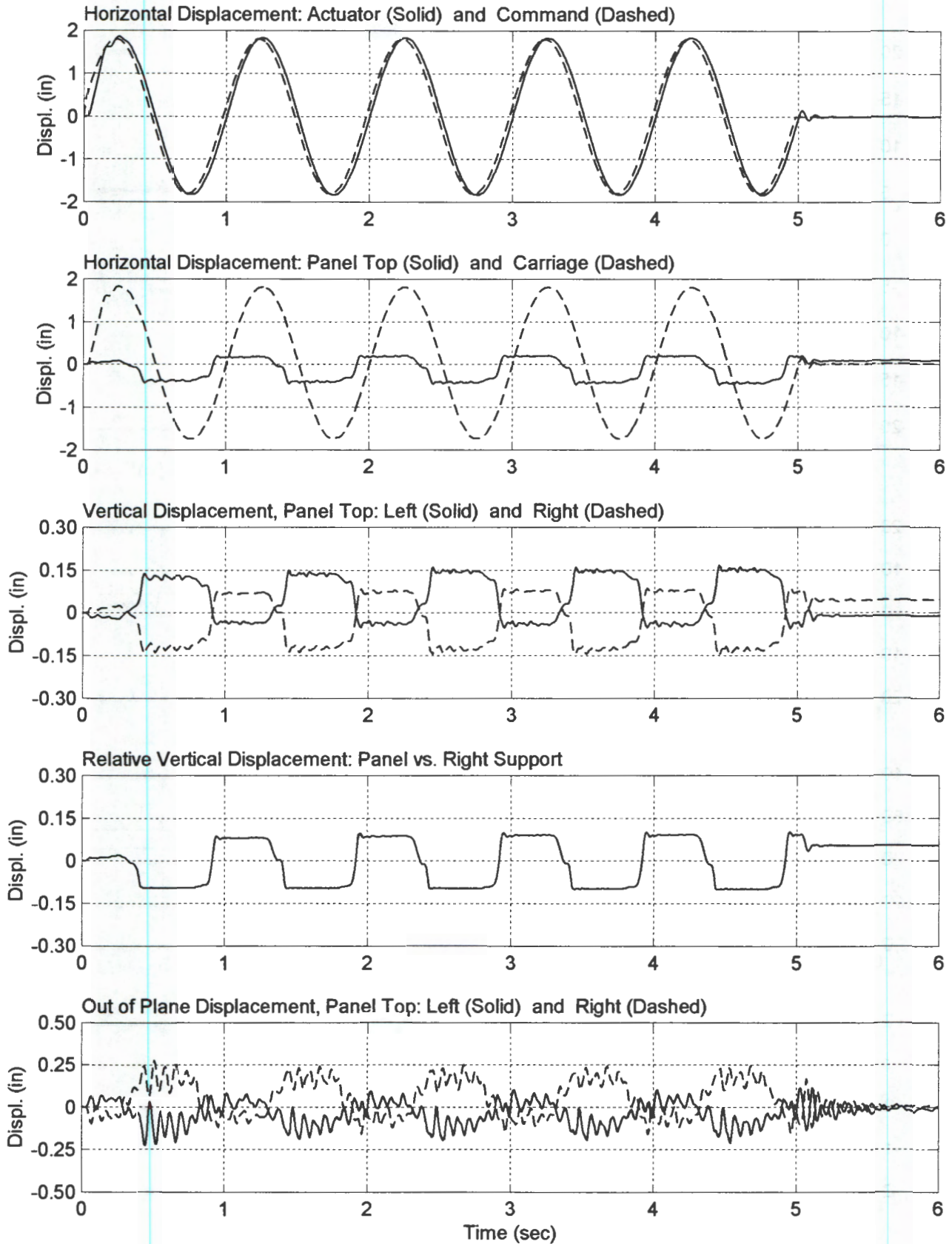

UCR Rivera Library--Test No. 6 Anchorage A One Device (T=100 ft-lbs)
Harmonic Motion (1 Hz, 1.8 in) File: 05221445.txt

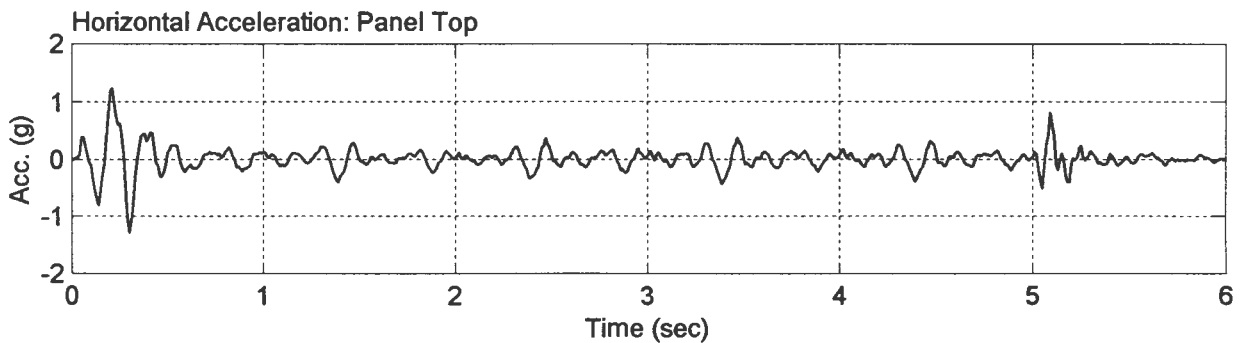
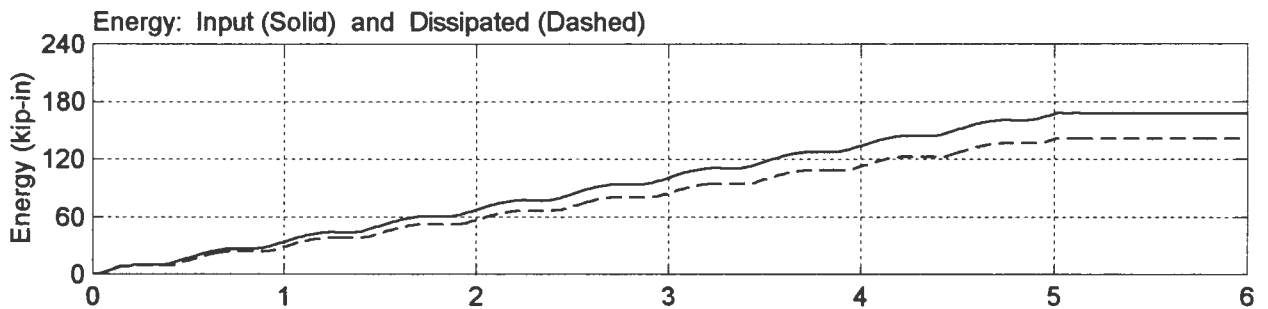
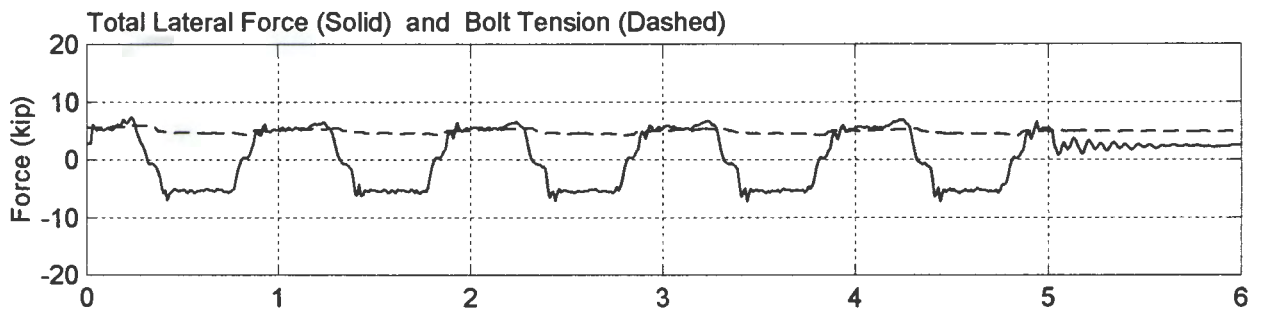
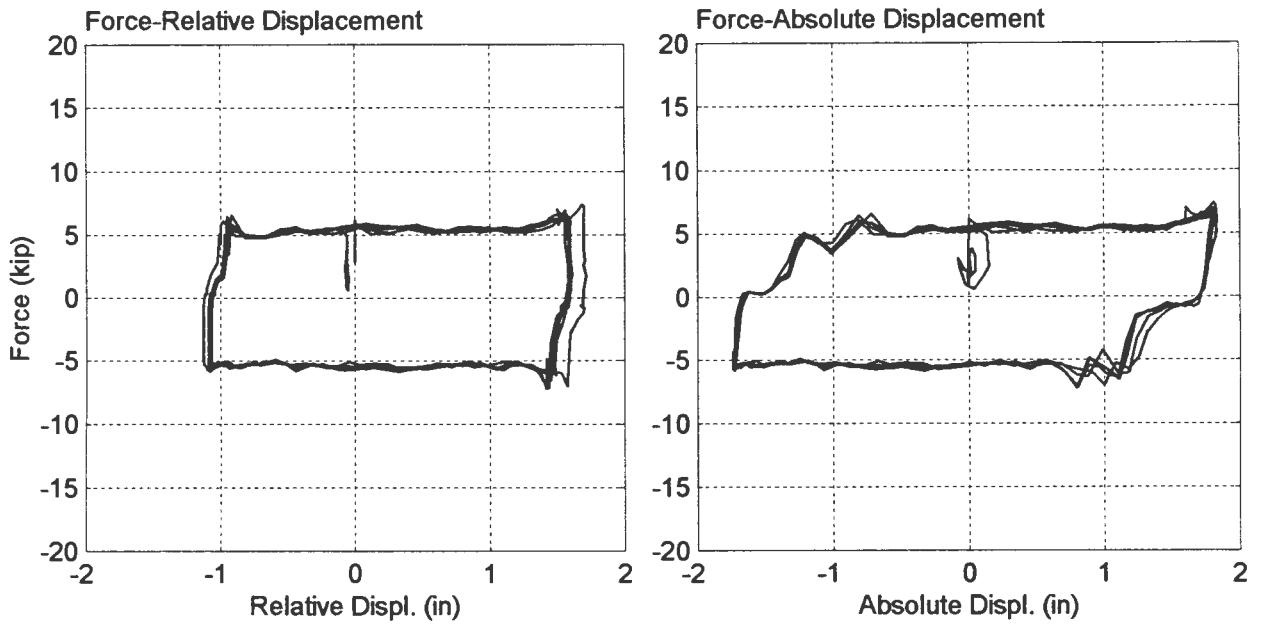

UCR Rivera Library--Test No. 7 Anchorage A One Device (T=100 ft-lbs)
Harmonic Motion (1.5 Hz, 1.8 in) File: 05221454.txt

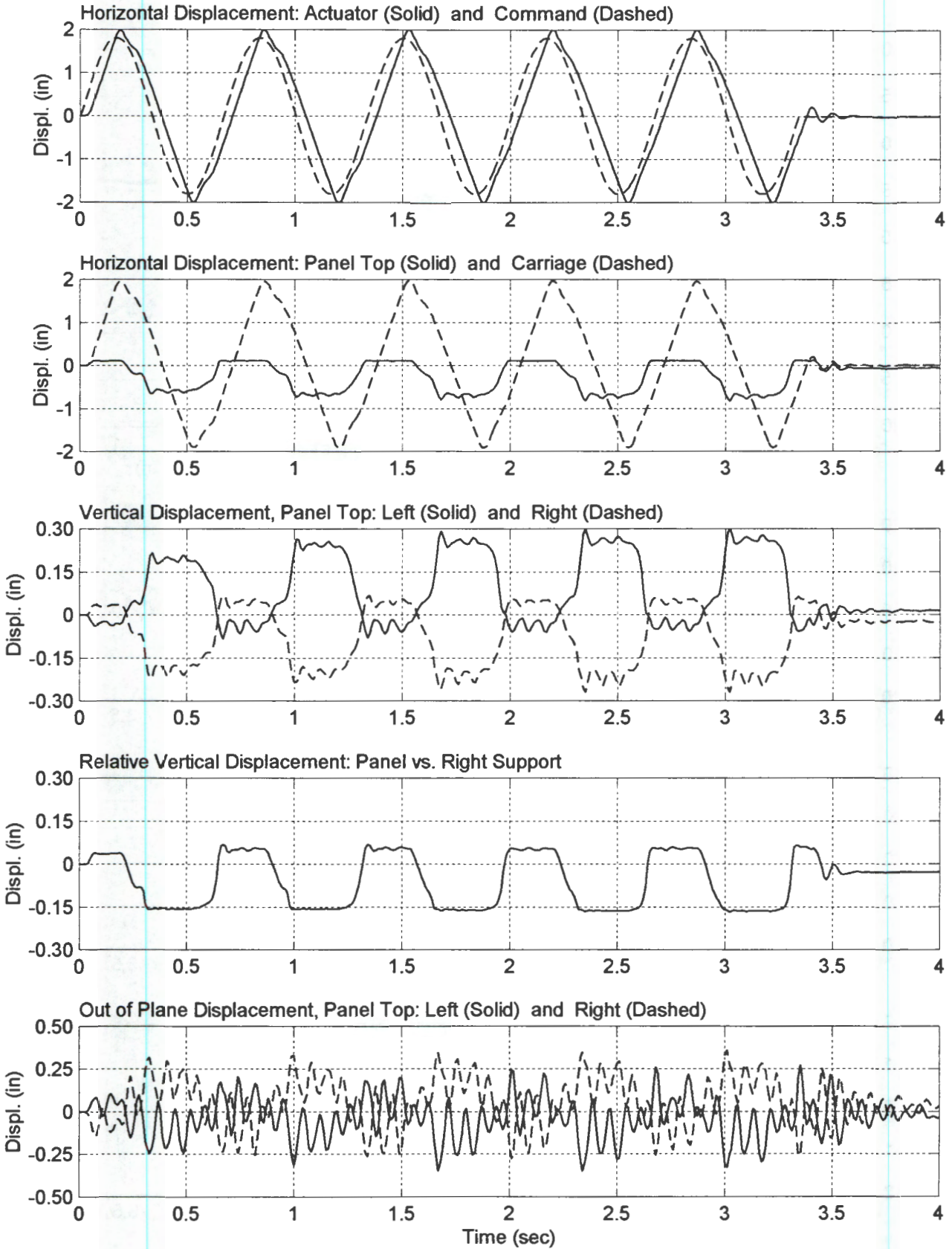

UCR Rivera Library--Test No. 7 Anchorage A One Device (T=100 ft-lbs)
Harmonic Motion (1.5 Hz, 1.8 in) File: 05221454.txt

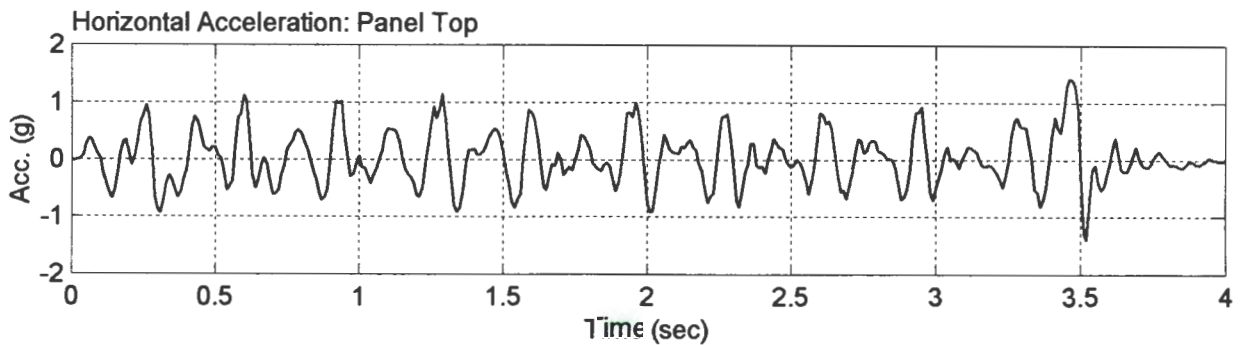
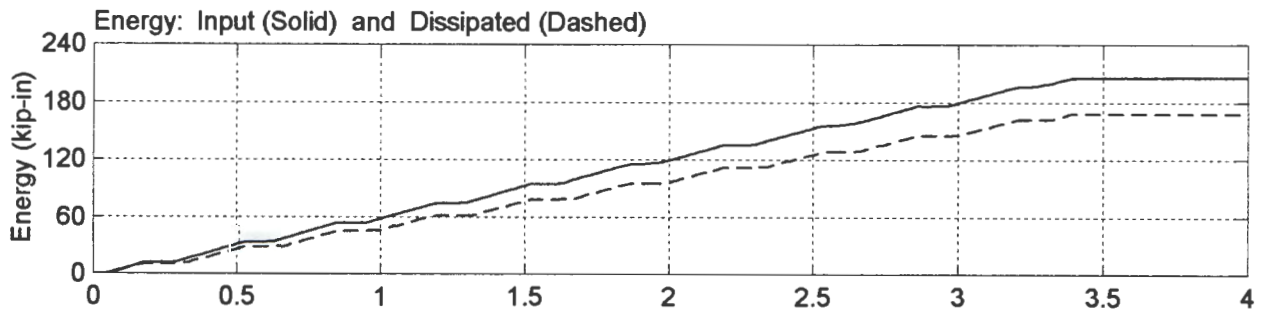
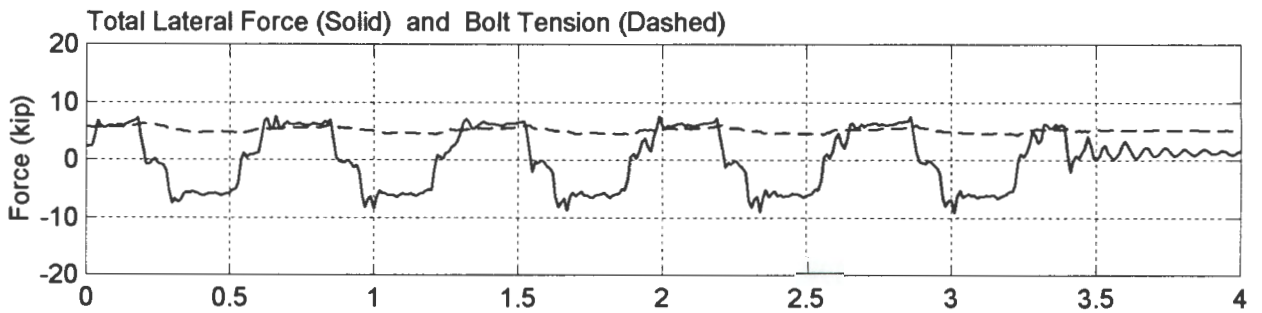
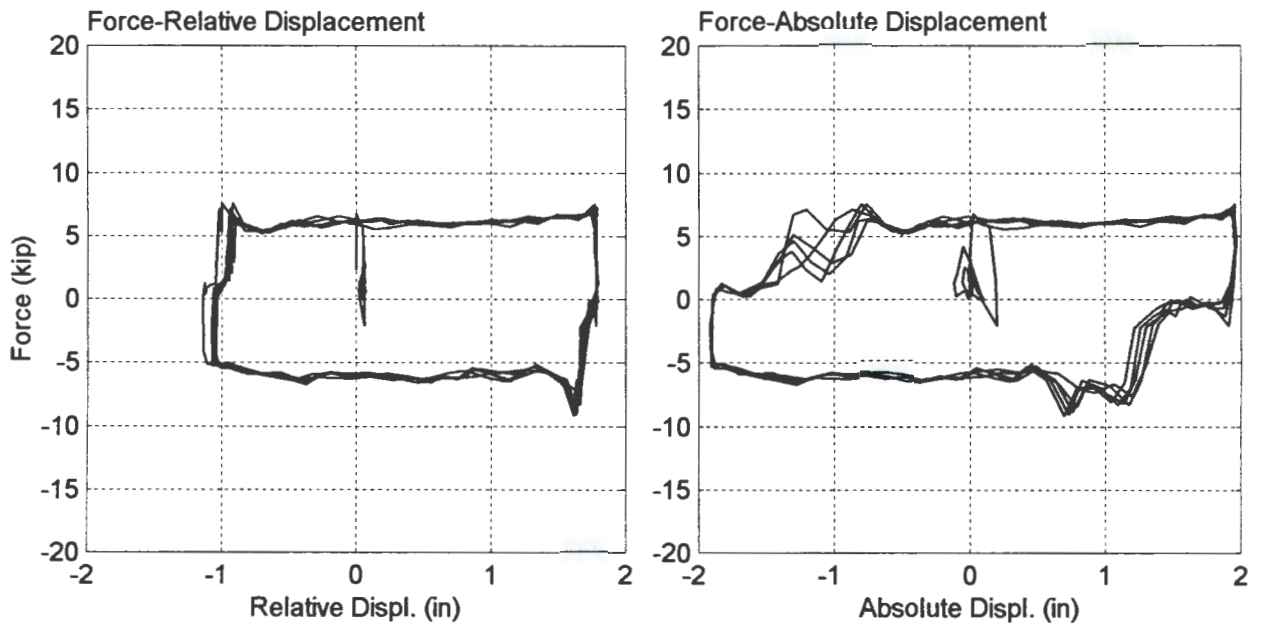

UCR Rivera Library--Test No. 8 Anchorage A Three Devices (T=100 ft-lbs)
Harmonic Motion (0.05 Hz, 1.8 in) File: 06041203.txt

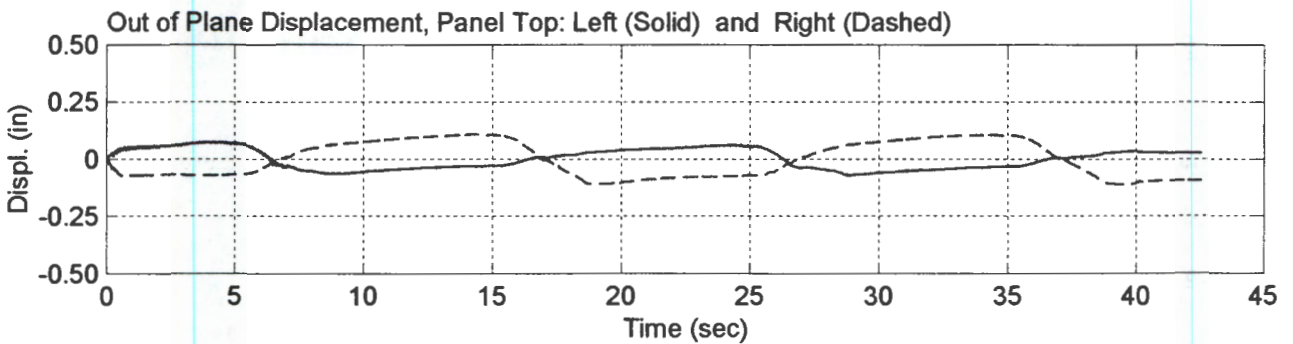
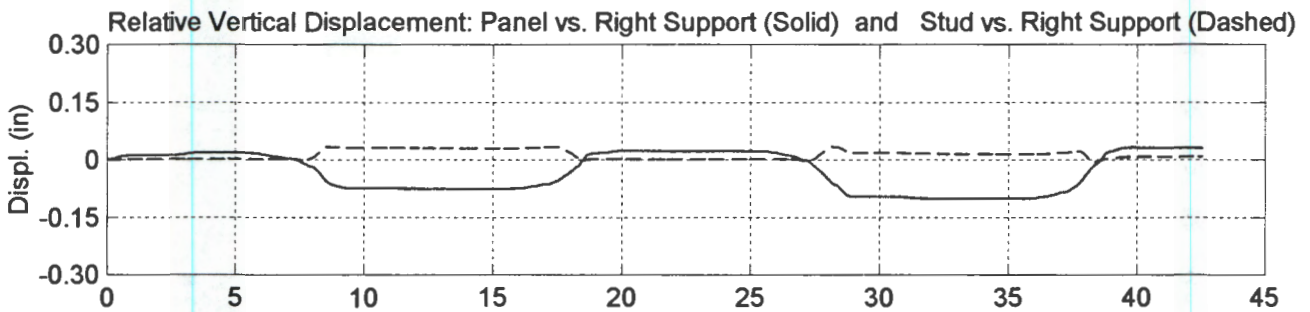
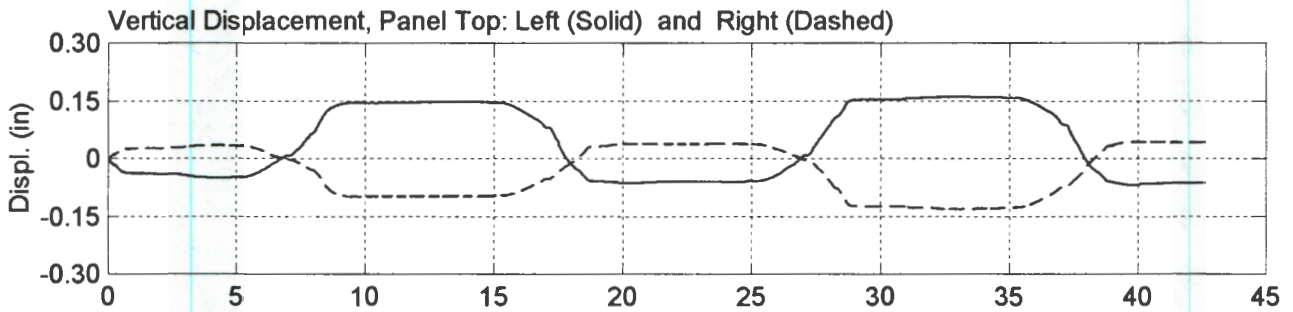
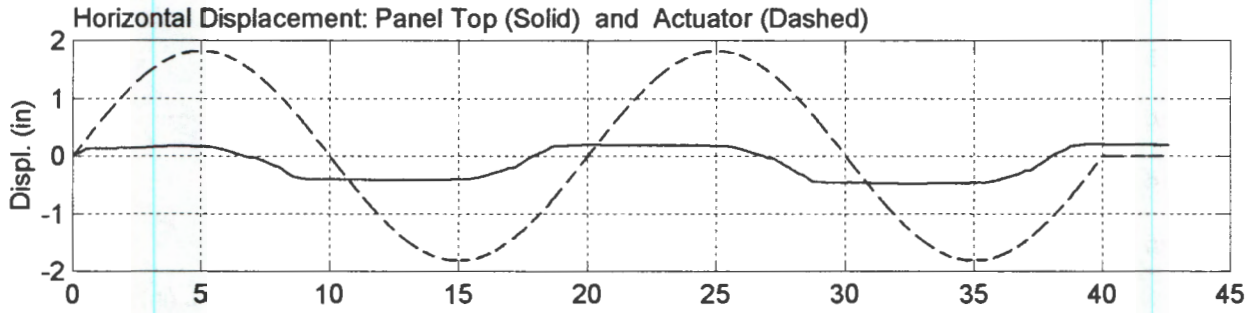
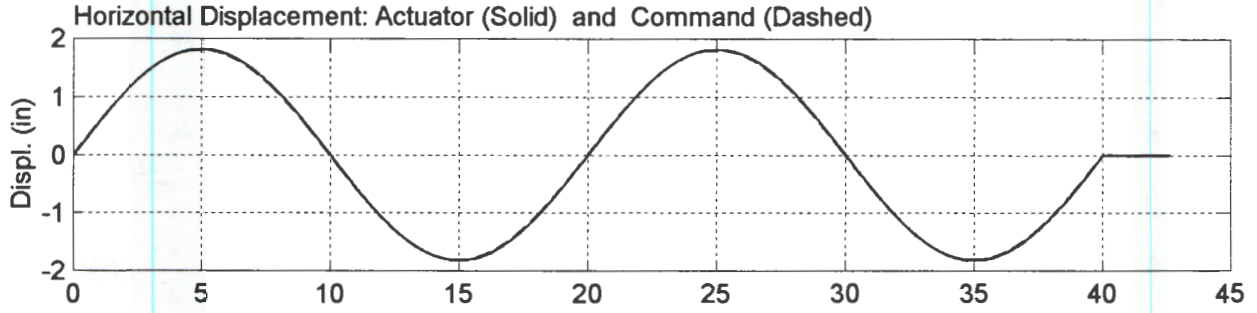

UCR Rivera Library--Test No. 8 Anchorage A Three Devices (T=100 ft-lbs)
Harmonic Motion (0.05 Hz, 1.8 in) File: 06041203.txt

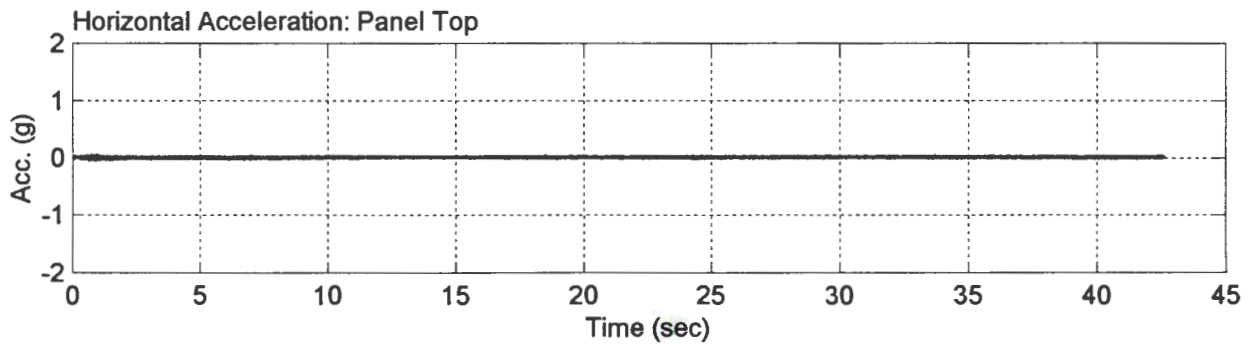
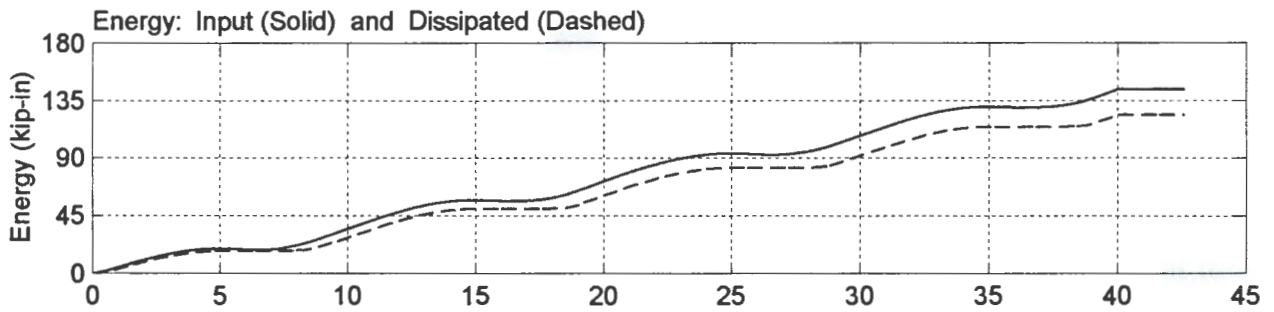
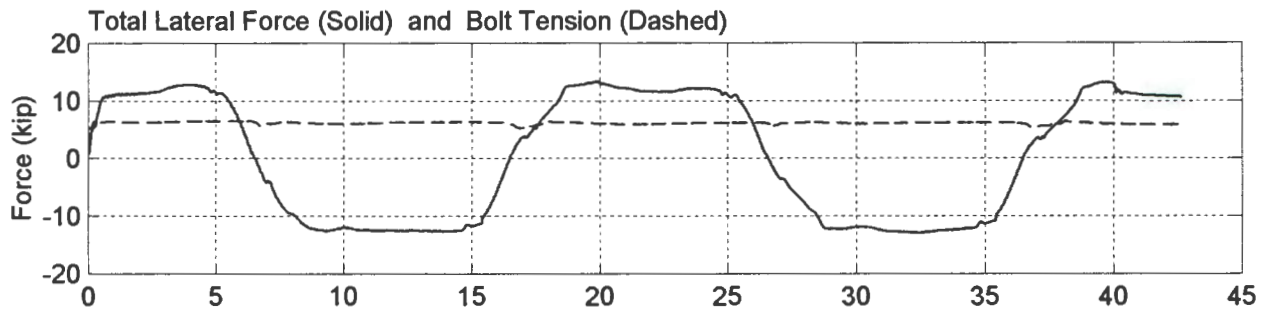
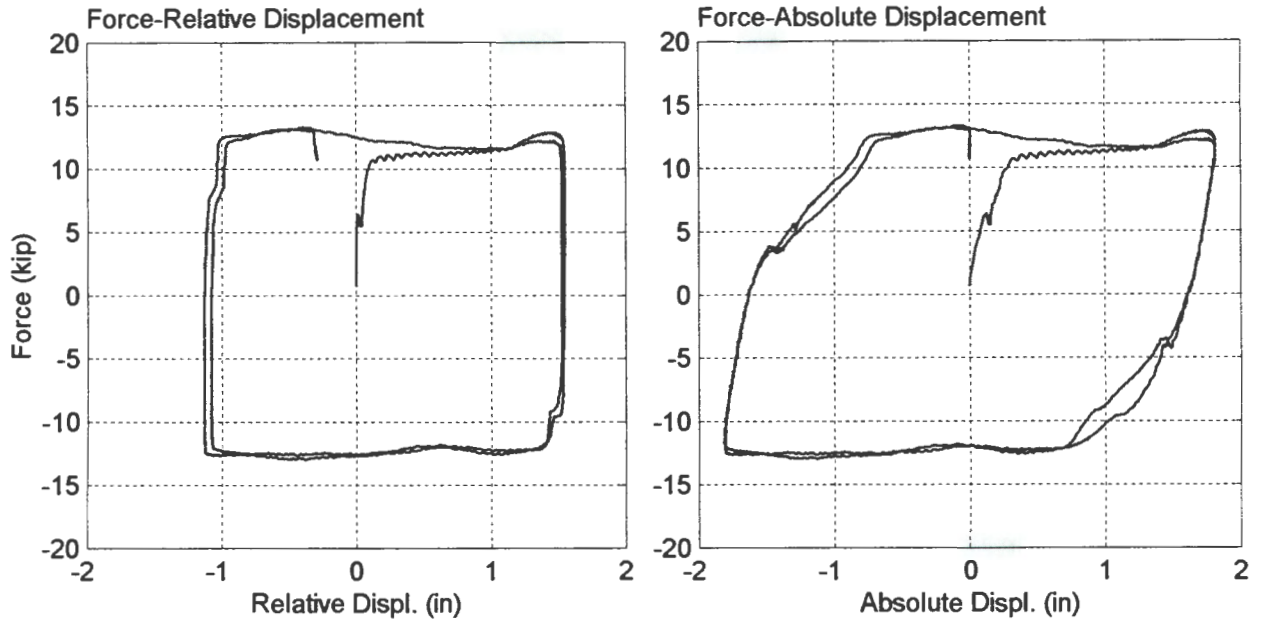

UCR Rivera Library--Test No. 9 Anchorage A Three Devices (T=150 ft-lbs)

Harmonic Motion (0.05 Hz, 1.8 in) File: 06041214.txt

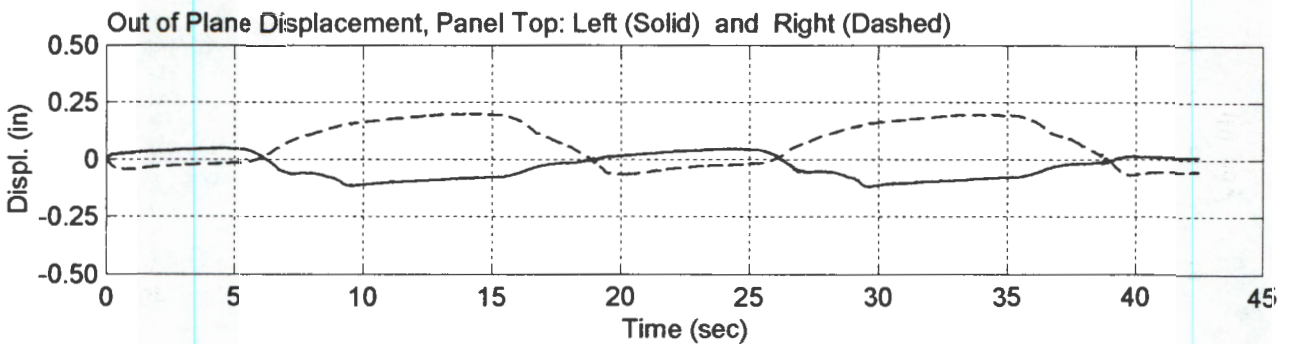
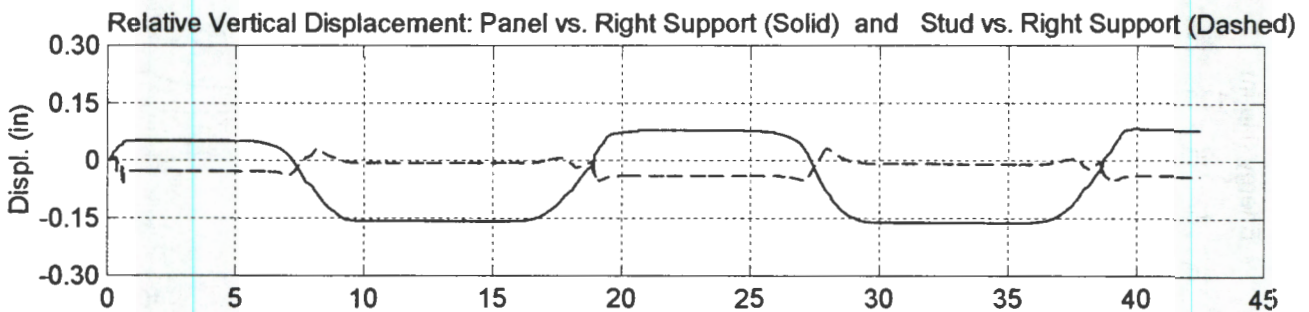
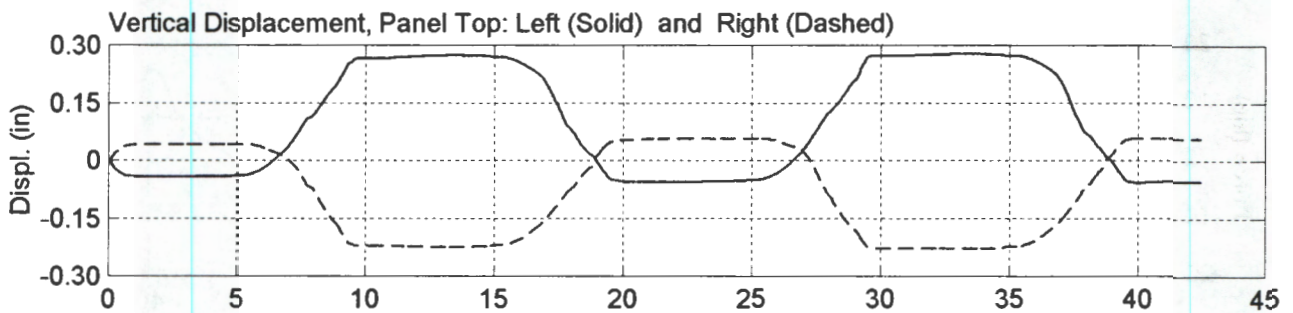
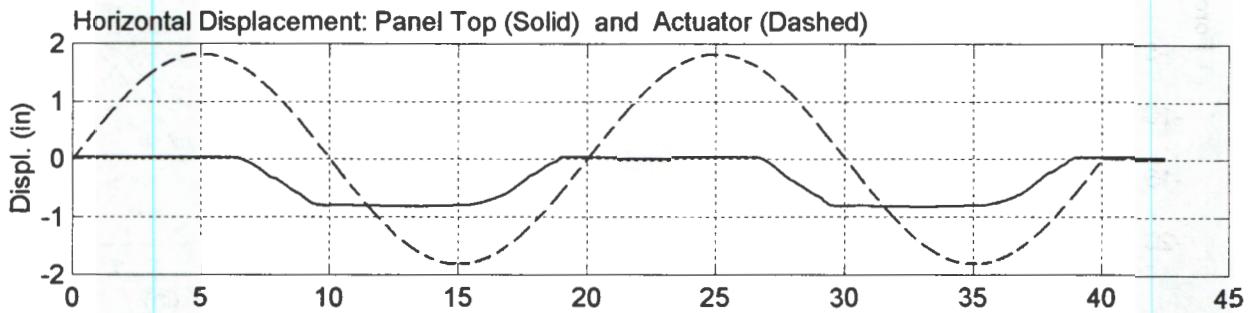
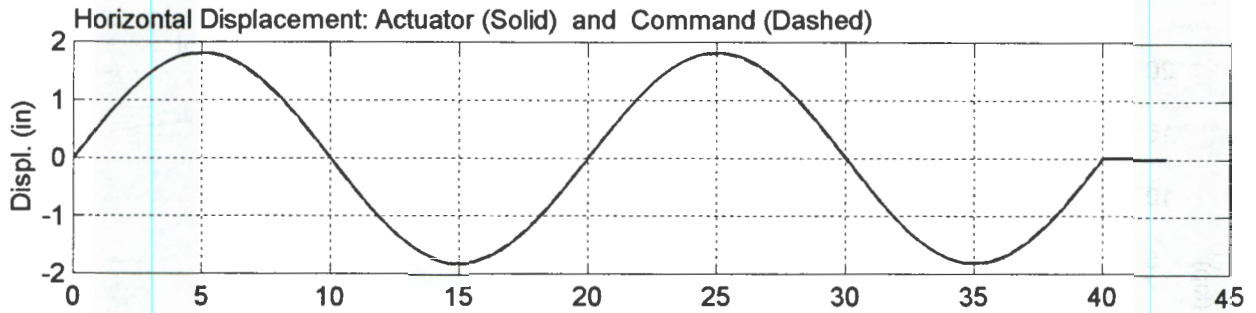

UCR Rivera Library--Test No. 9 Anchorage A Three Devices (T=150 ft-lbs)
Harmonic Motion (0.05 Hz, 1.8 in) File: 06041214.txt

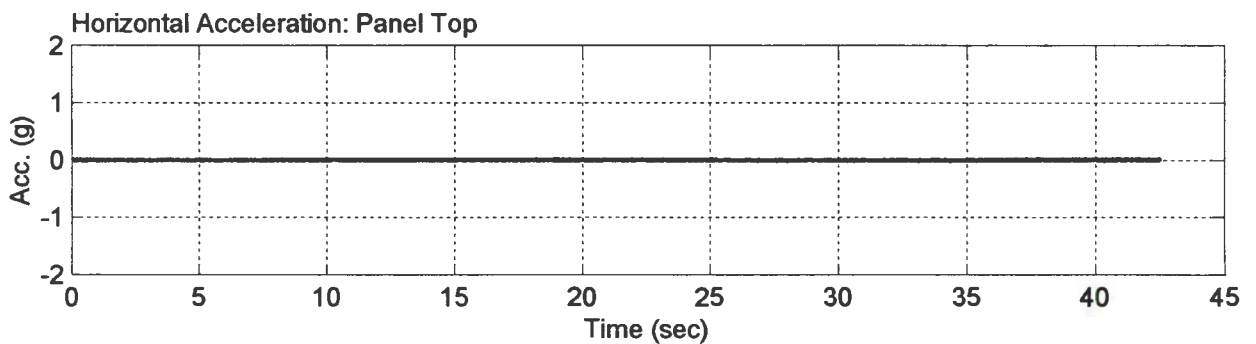
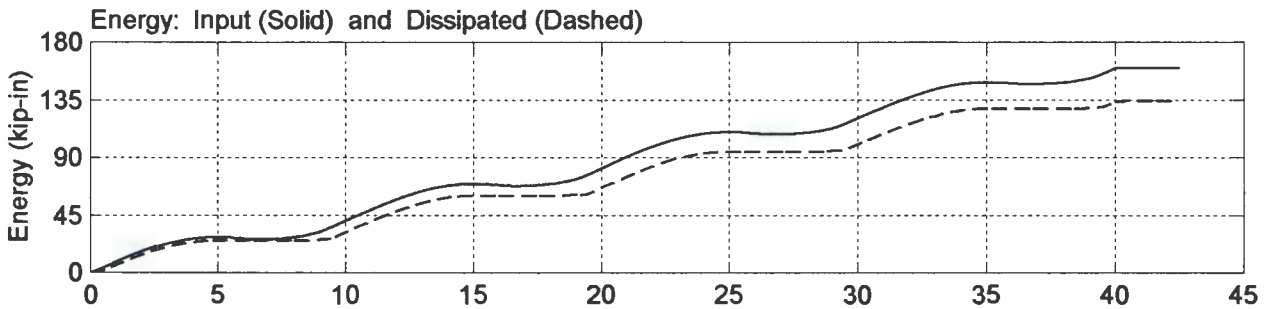
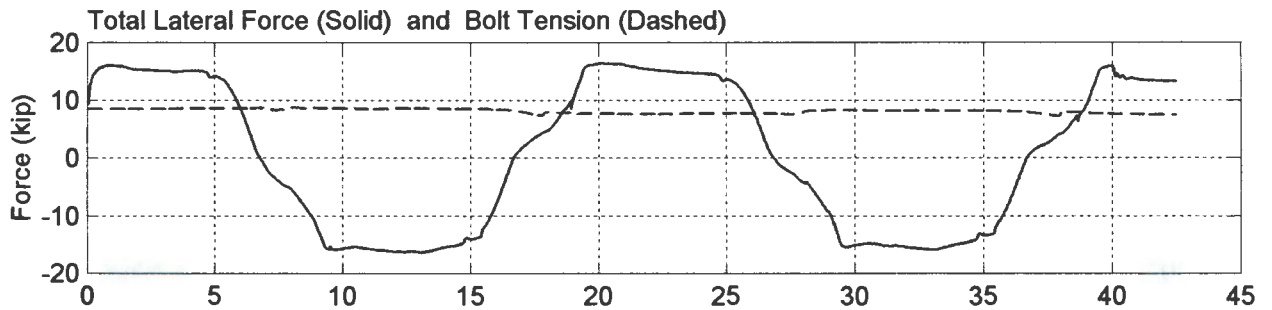
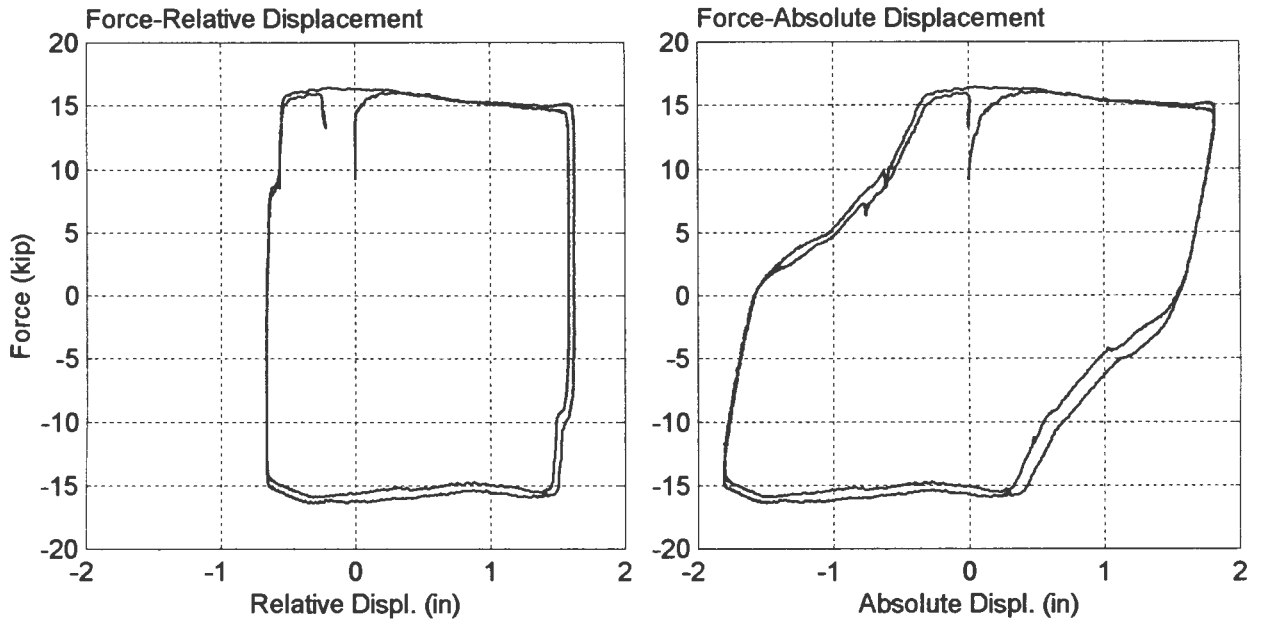

UCR Rivera Library--Test No. 10 Anchorage A Three Devices (T=100 ft-lbs)
 Harmonic Motion (0.05 Hz, 1.8 in) File: 06101049.txt

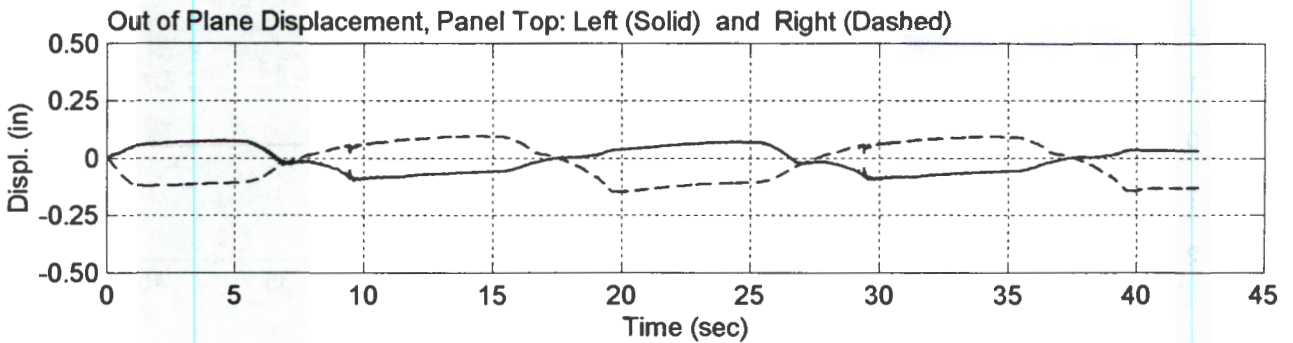
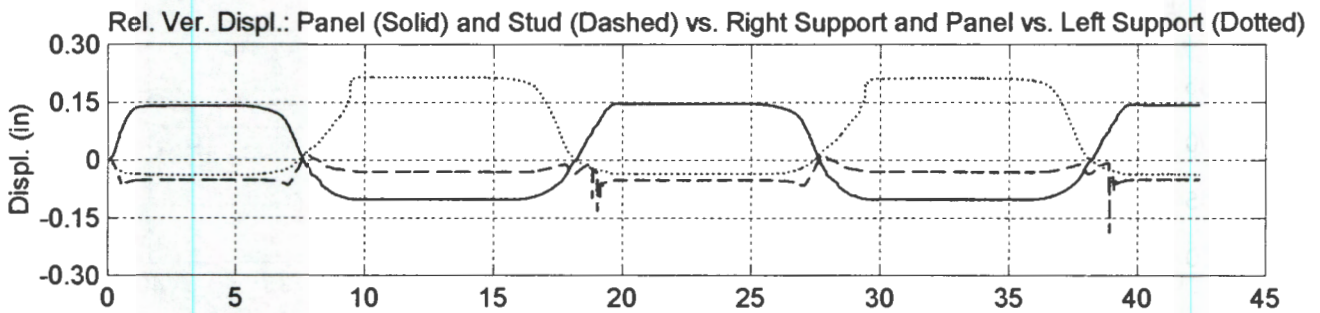
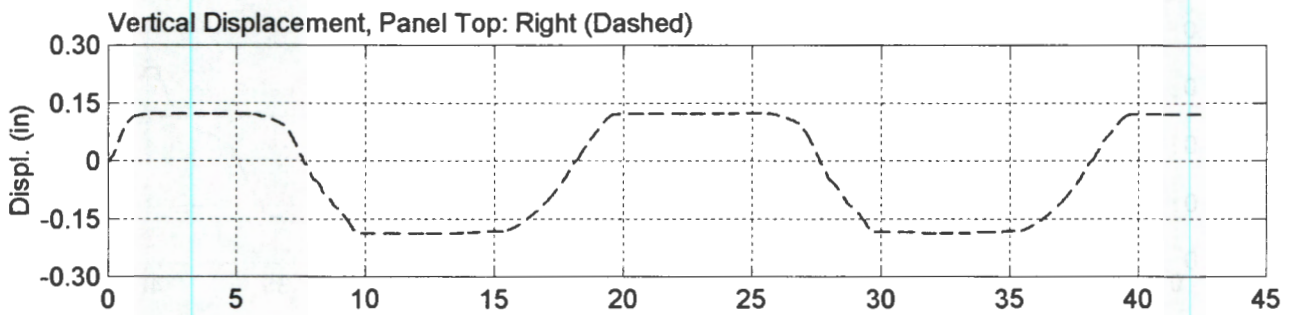
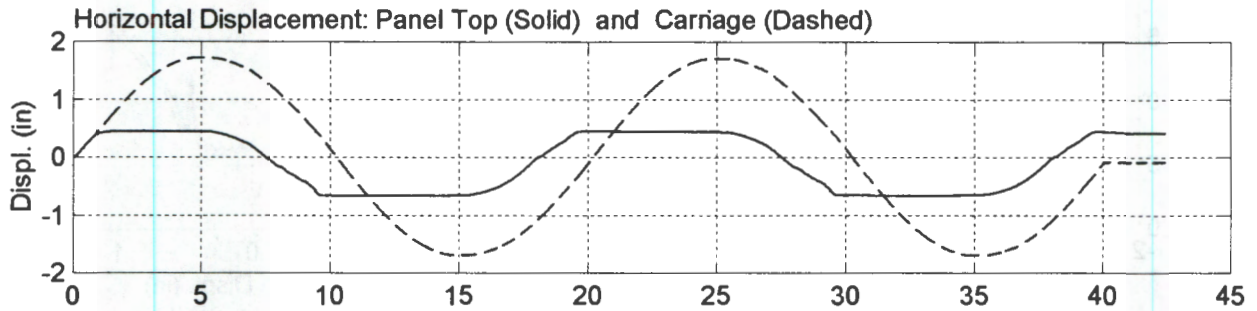
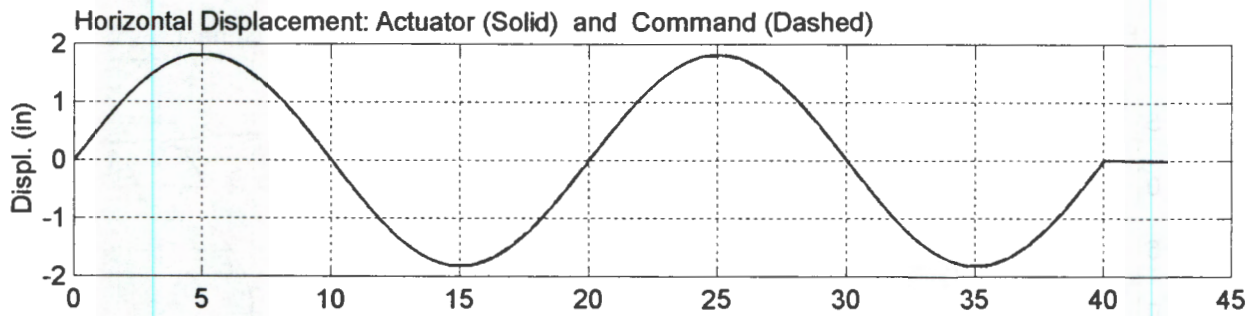

UCR Rivera Library--Test No. 10 Anchorage A Three Devices (T=100 ft-lbs)
Harmonic Motion (0.05 Hz, 1.8 in) File: 06101049.txt

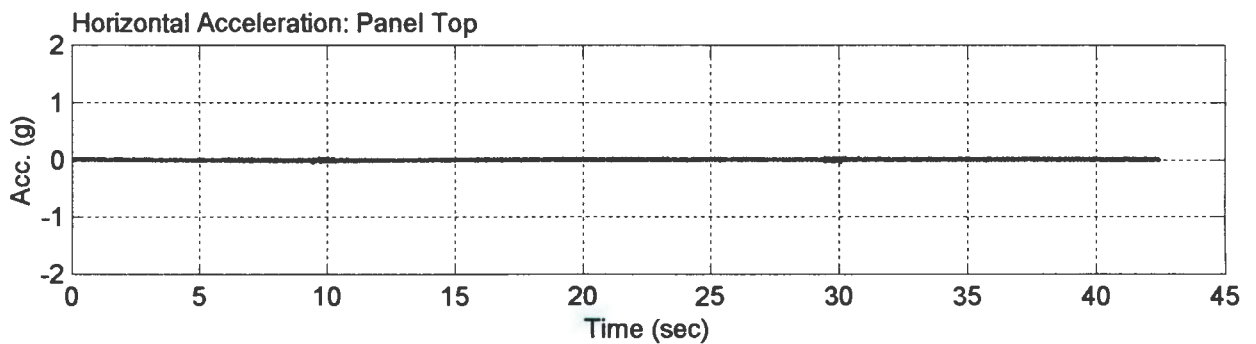
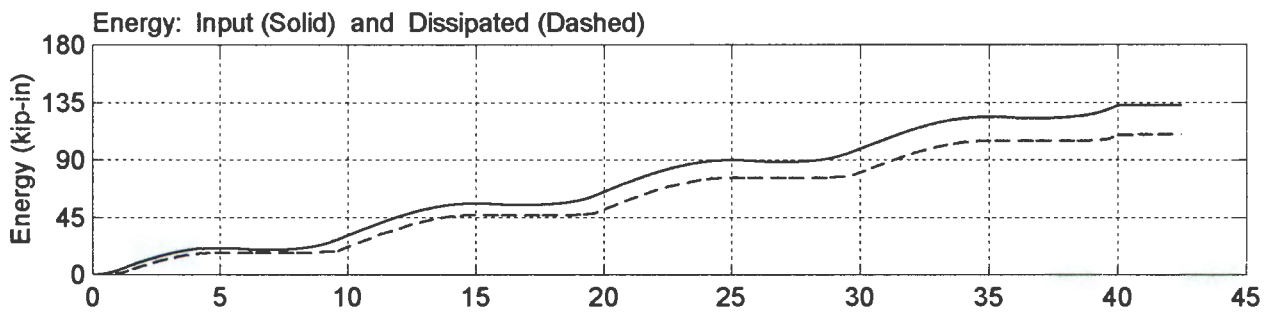
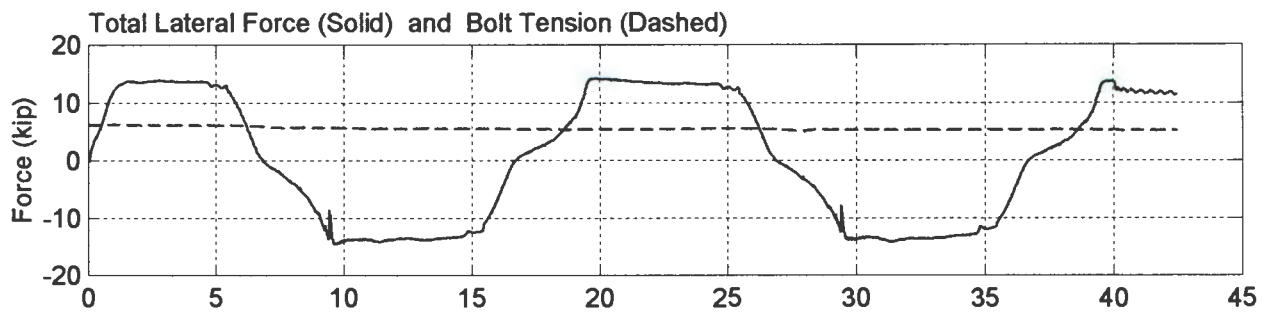
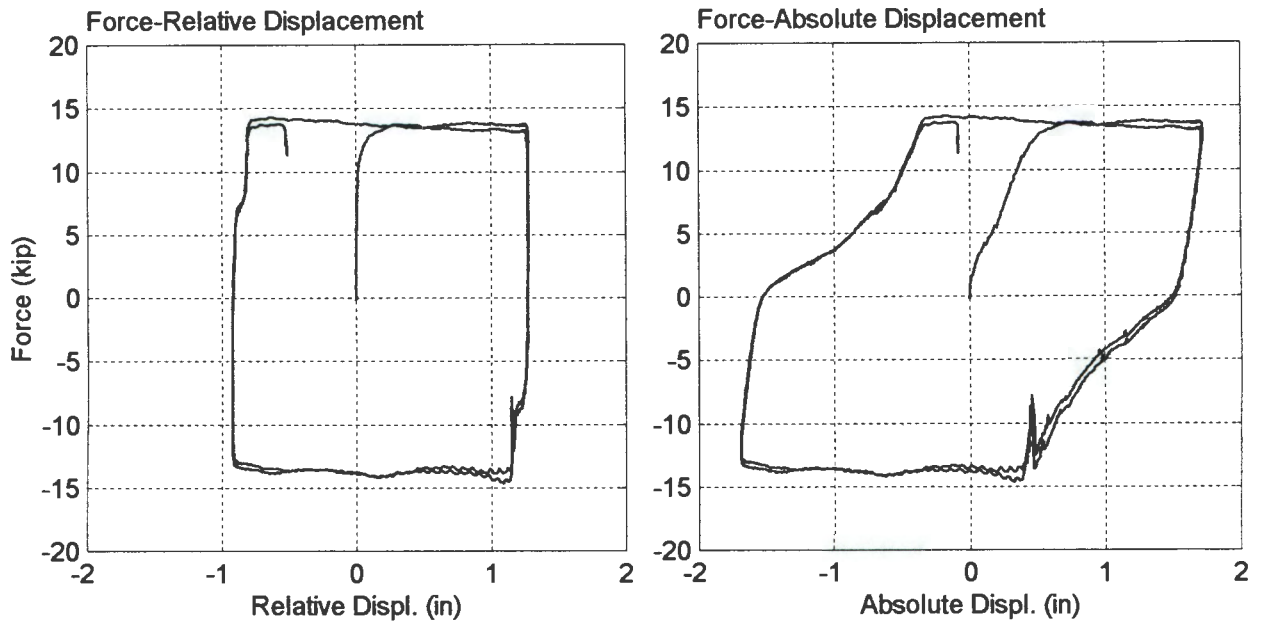

UCR Rivera Library--Test No. 11 Anchorage A Three Devices (T=100 ft-lbs)
Seismic Motion (Max. Ampl.=1.1 in) File: 06101117.txt

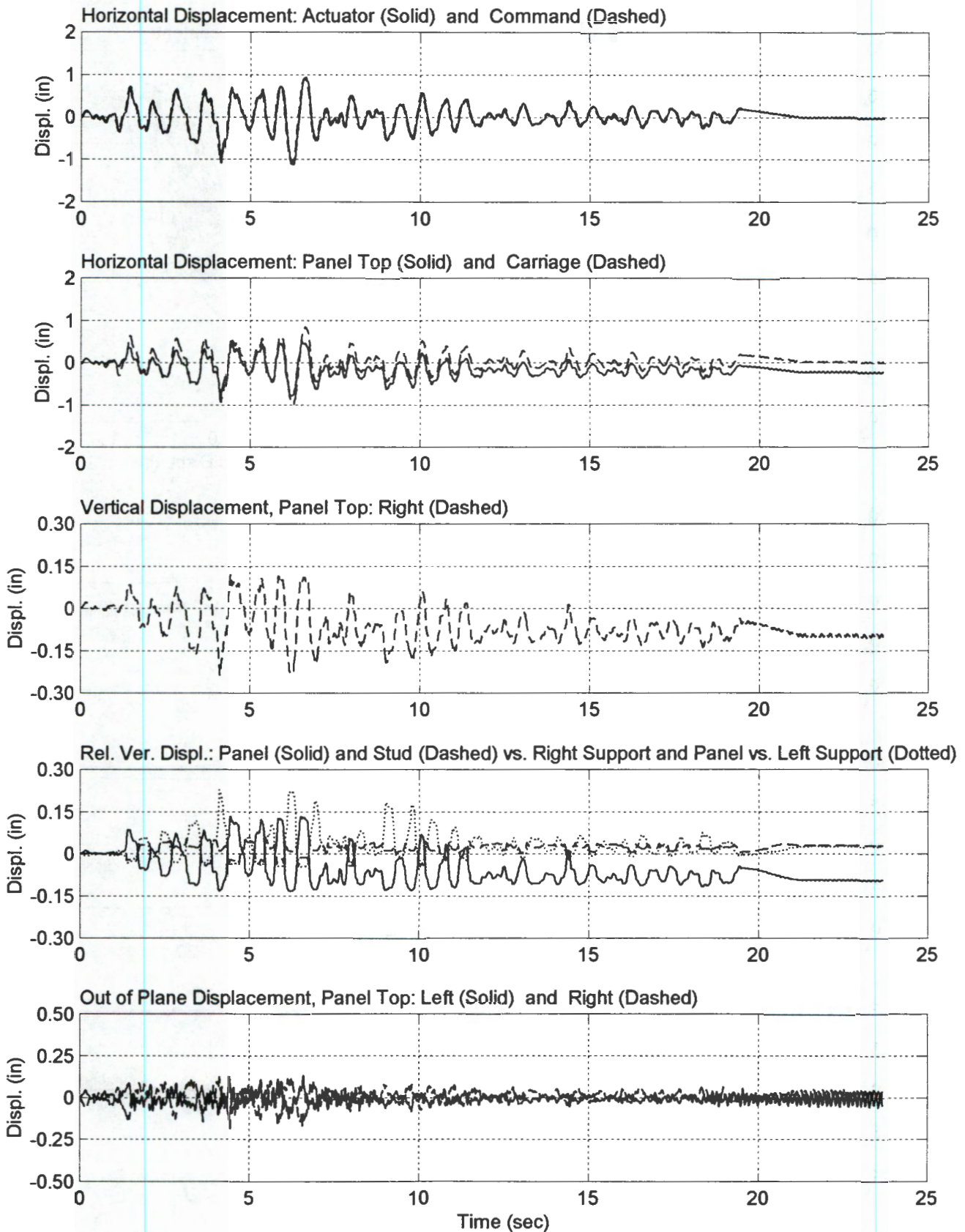

UCR Rivera Library--Test No. 11 Anchorage A Three Devices (T=100 ft-lbs)
Seismic Motion (Max. Ampl.=1.1 in) File: 06101117.txt

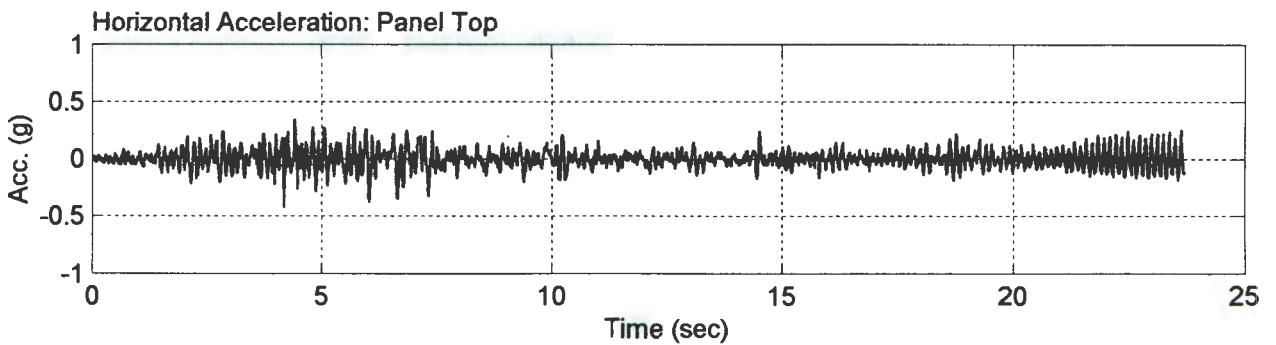
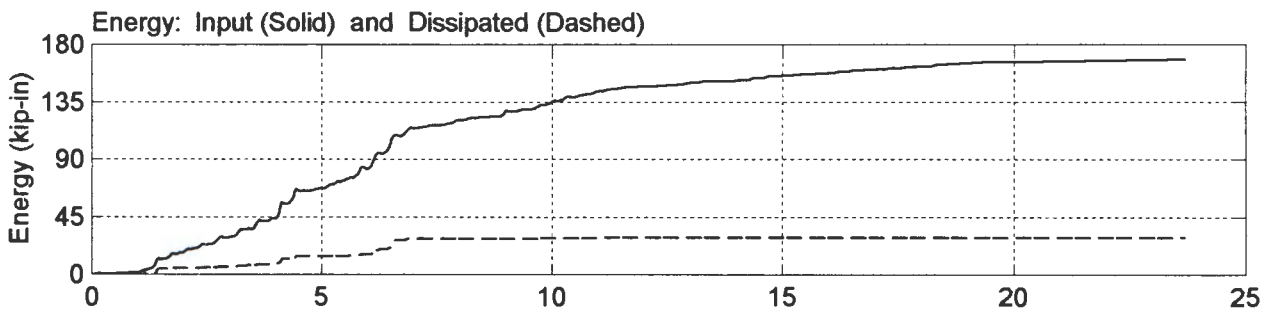
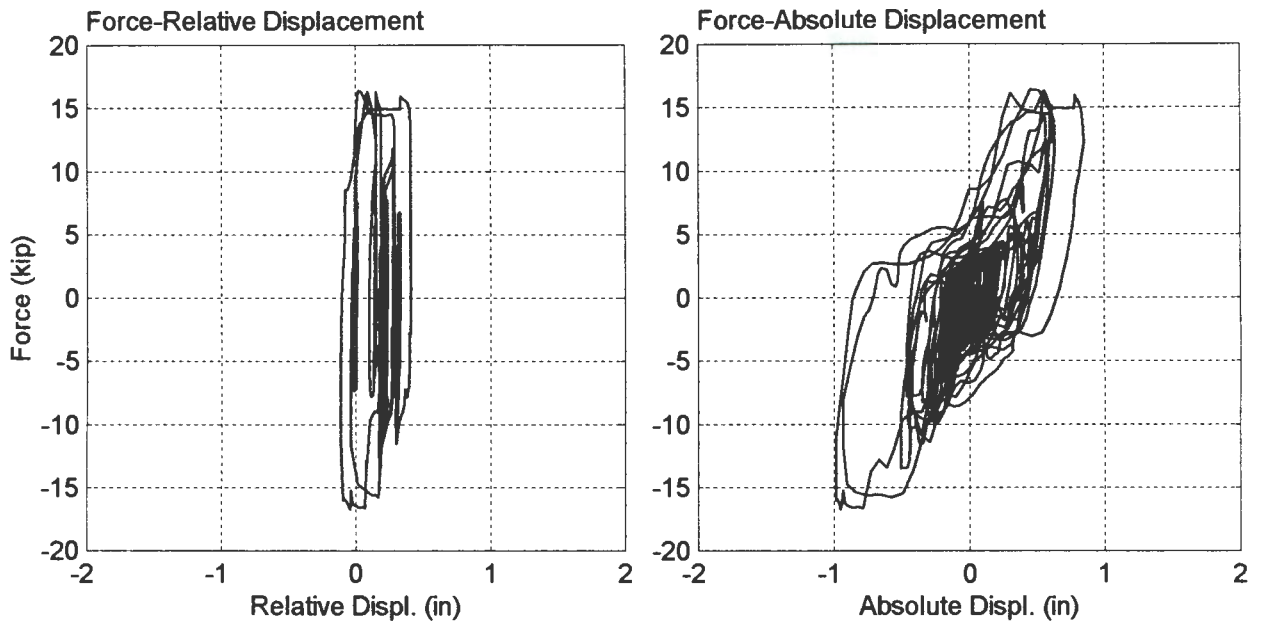

UCR Rivera Library--Test No. 12 Anchorage A Three Devices (T=100 ft-lbs)
Seismic Motion (Max. Ampl.=1.65 in) File: 06101134.txt

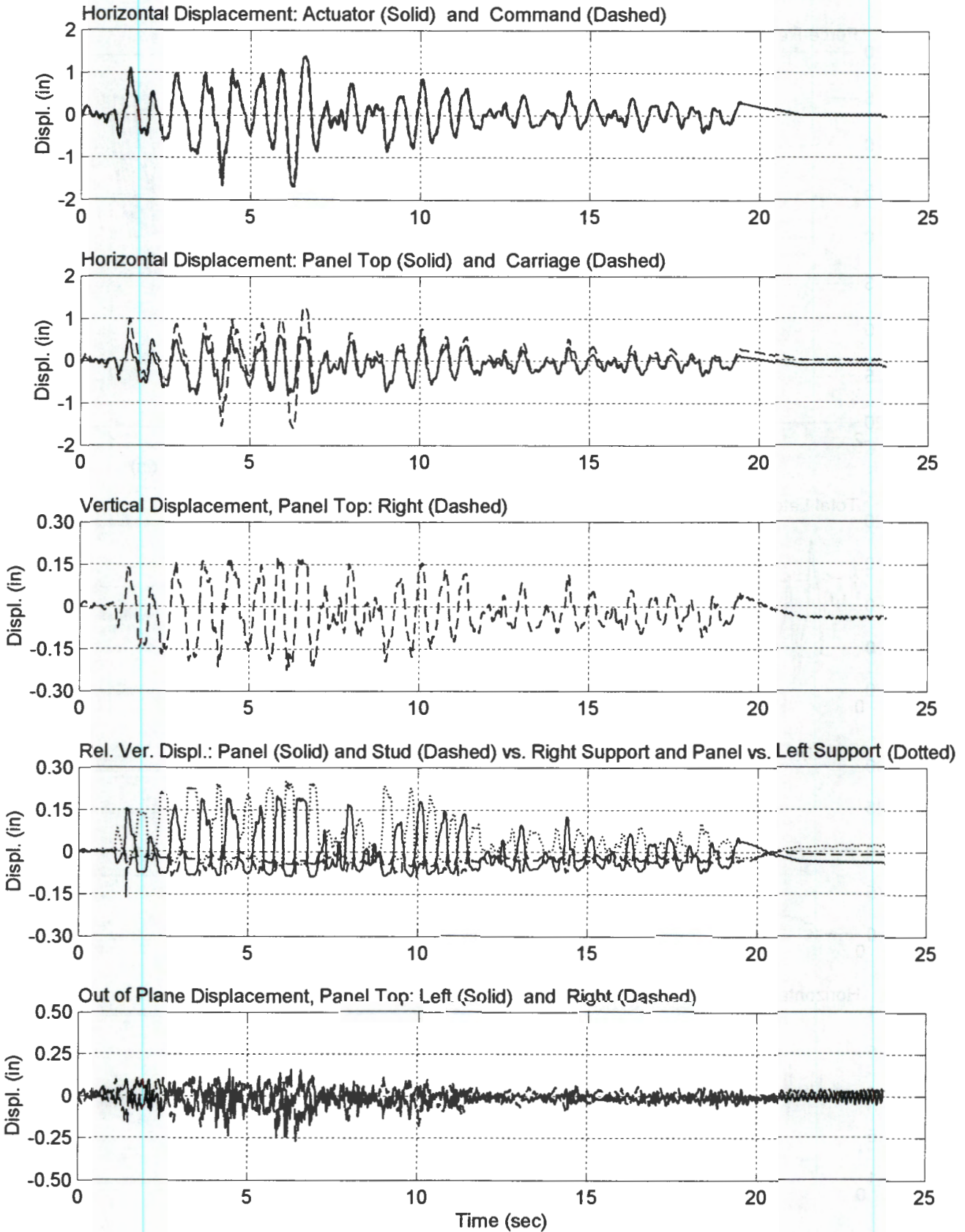

UCR Rivera Library--Test No. 12 Anchorage A Three Devices (T=100 ft-lbs)
Seismic Motion (Max. Ampl.=1.65 in) File: 06101134.txt

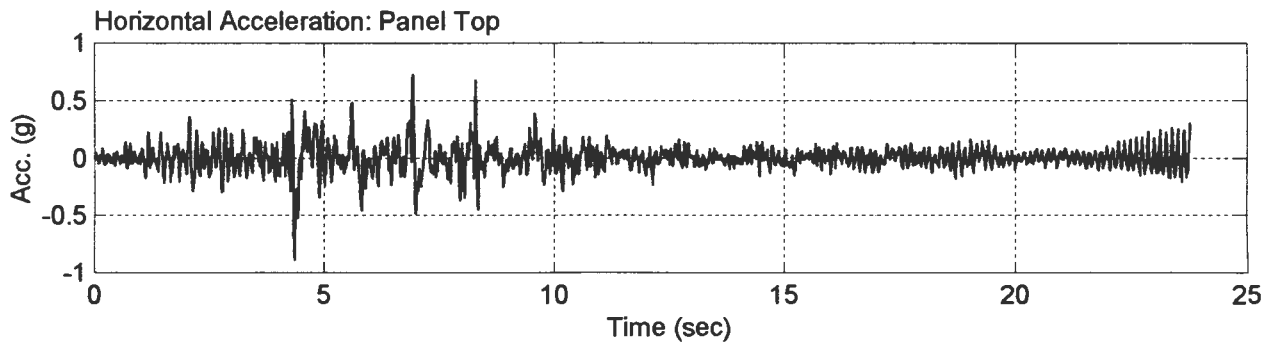
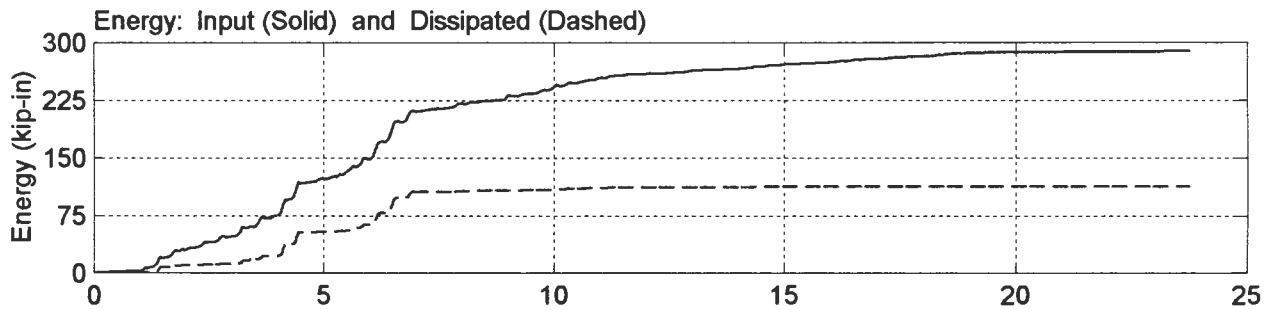
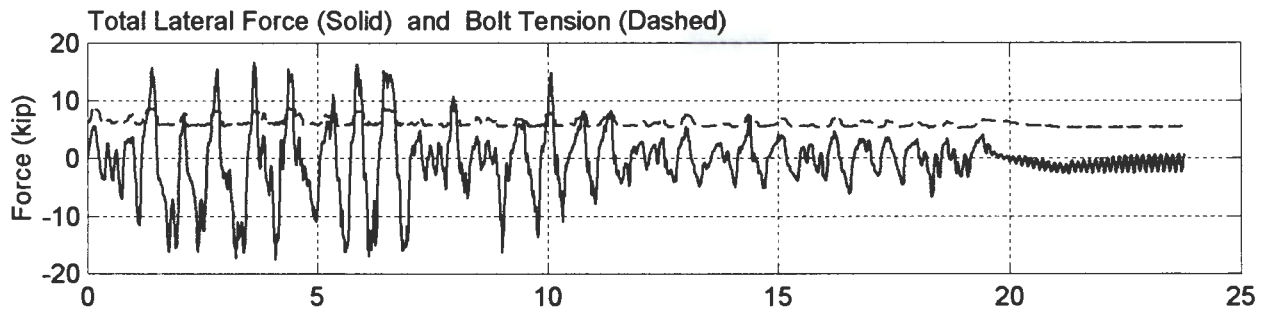
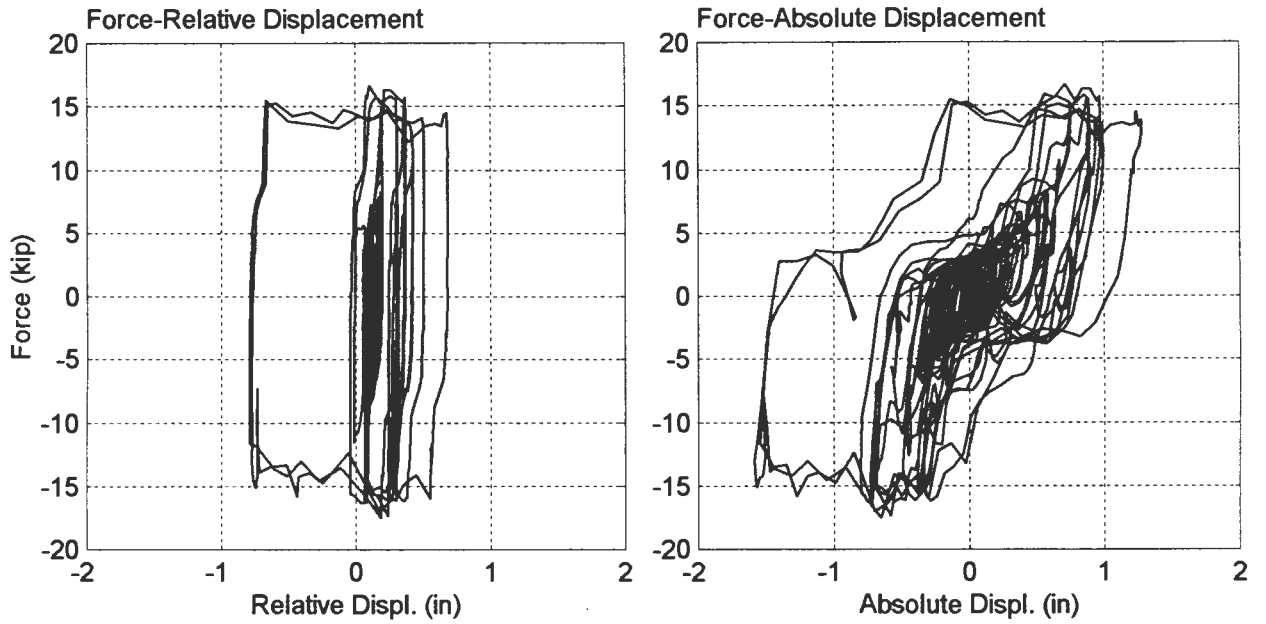

UCR Rivera Library--Test No. 13 Anchorage A Three Devices (T=100 ft-lbs)

Harmonic Motion (1.5 Hz, 1.8 in) File: 06101148.txt

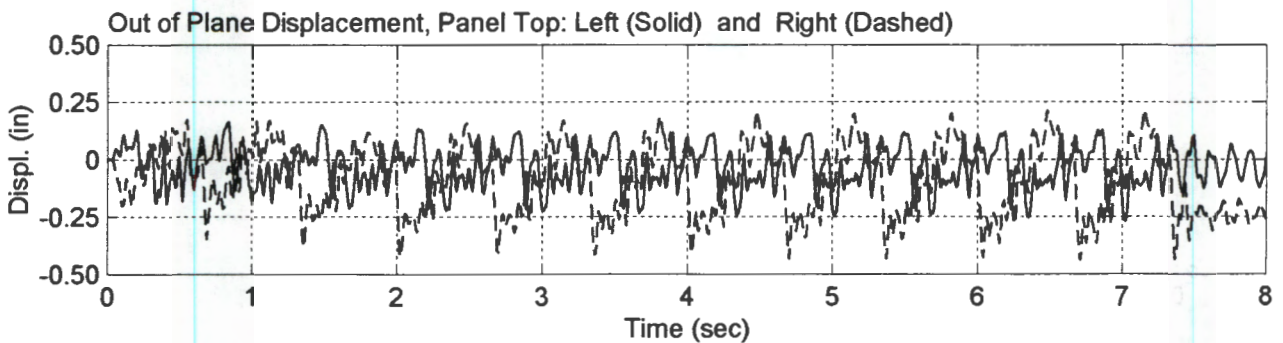
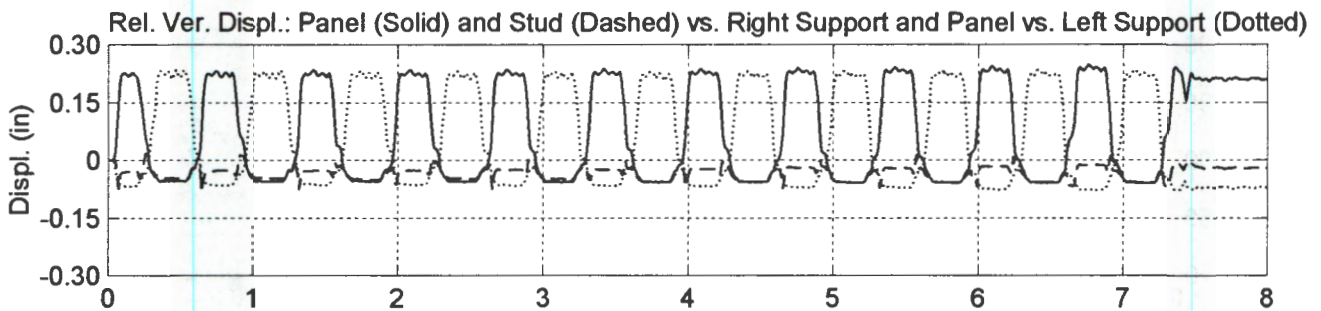
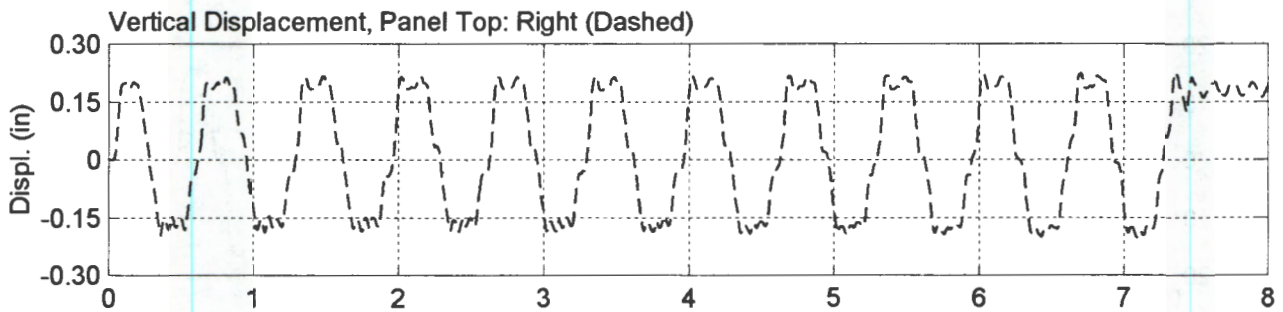
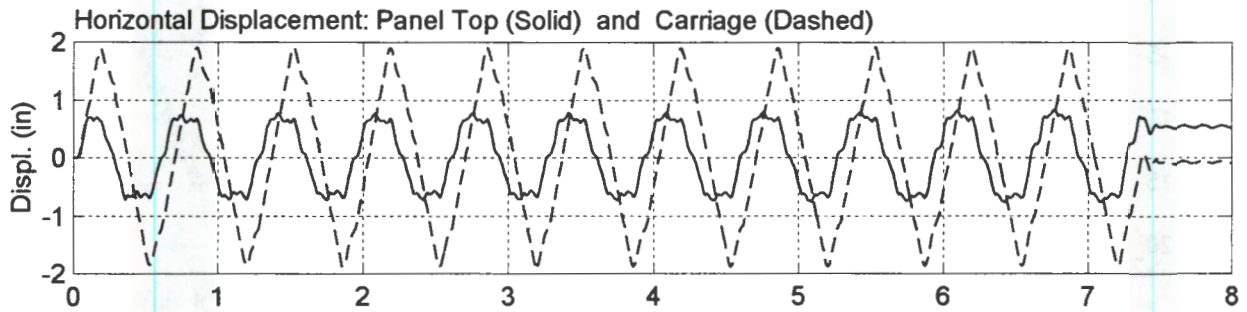
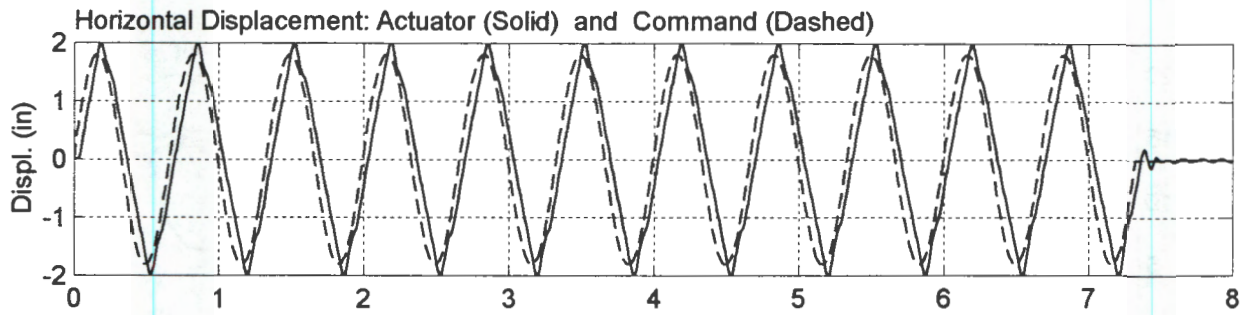

UCR Rivera Library--Test No. 13 Anchorage A Three Devices (T=100 ft-lbs)
Harmonic Motion (1.5 Hz, 1.8 in) File: 06101148.txt

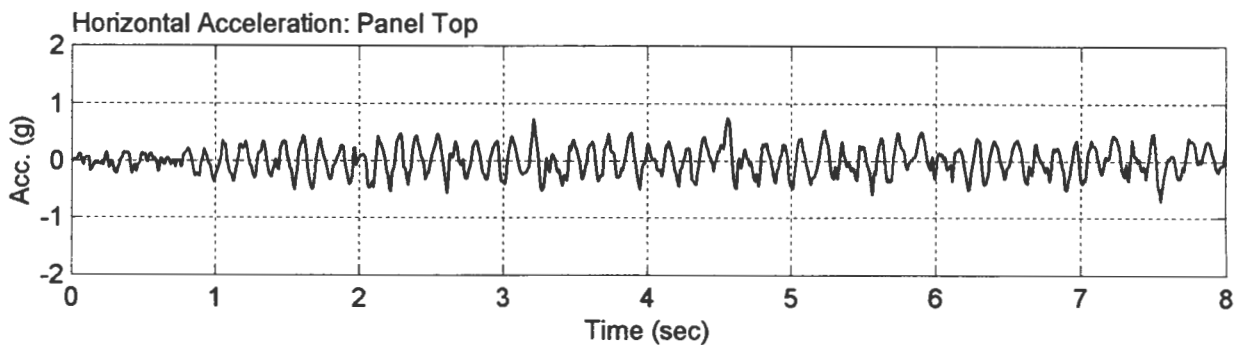
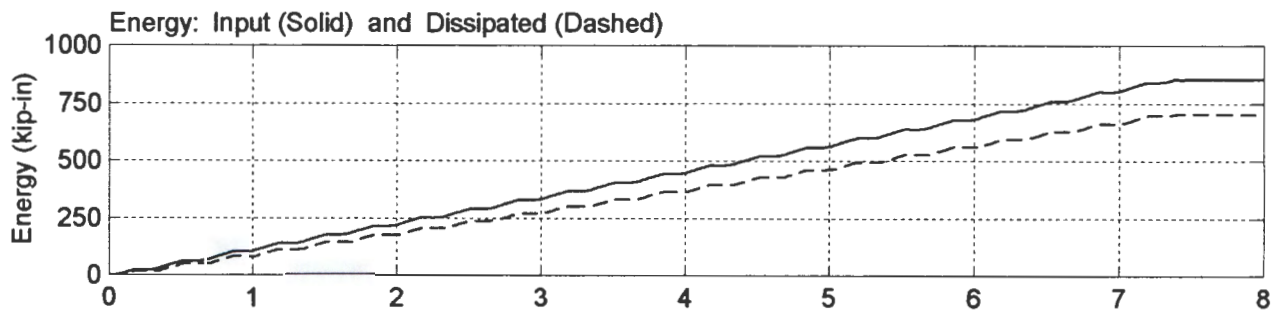
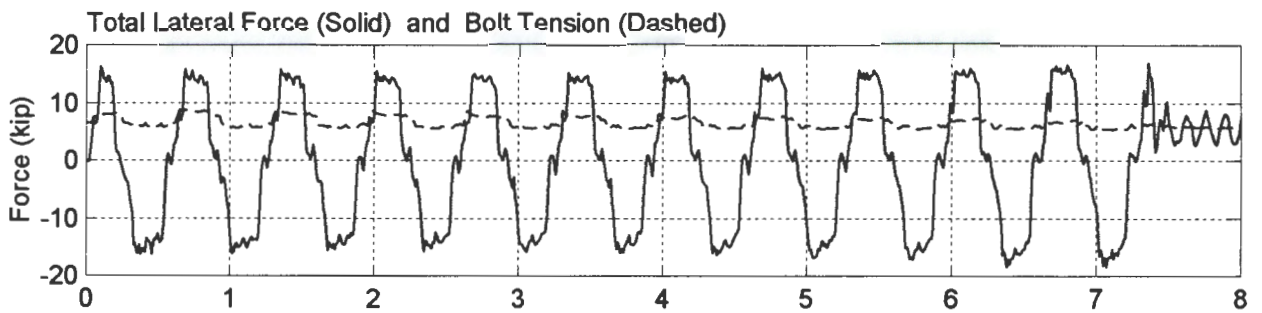
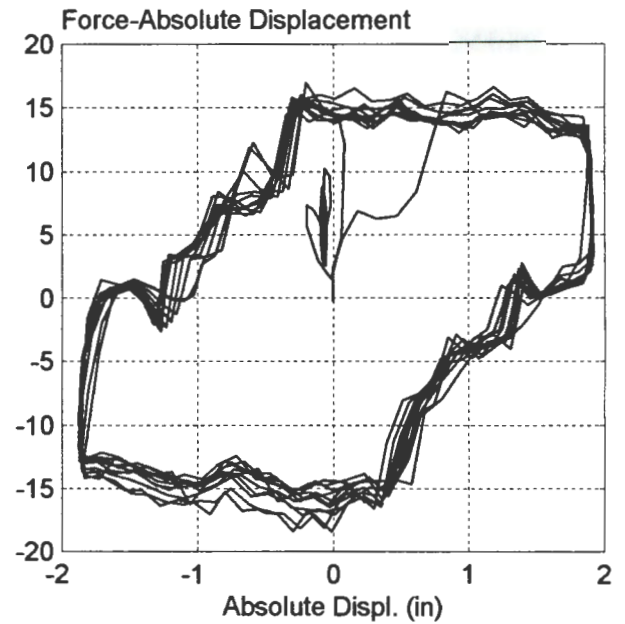
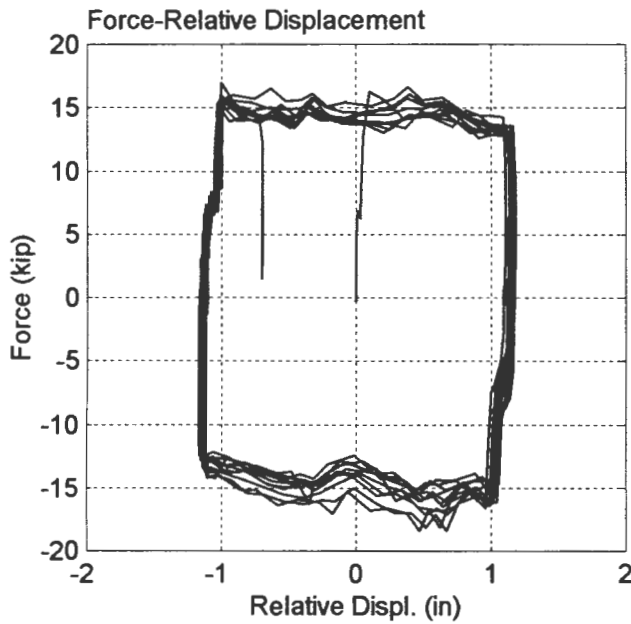

UCR Rivera Library--Test No. 14 Anchorage B Three Devices (T=50 ft-lbs)

Harmonic Motion (0.05 Hz, 1.8 in) File: 06271234.txt

Horizontal Displacement: Actuator (Solid) and Command (Dashed)

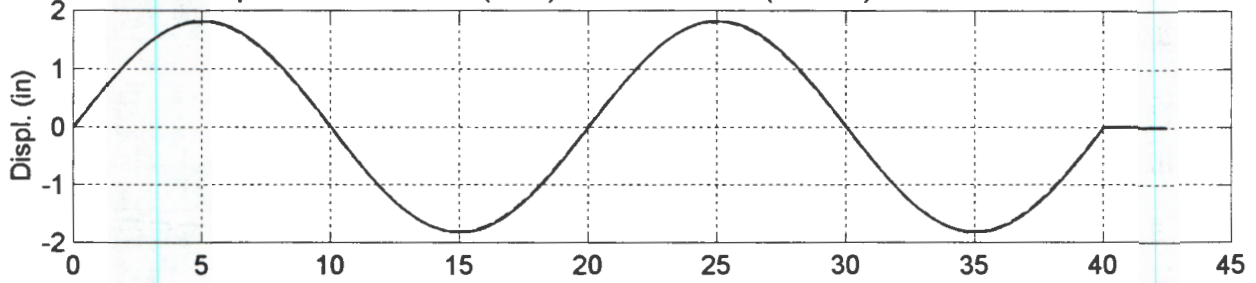

Horizontal Displacement: Panel Top (Solid) and Carriage (Dashed)

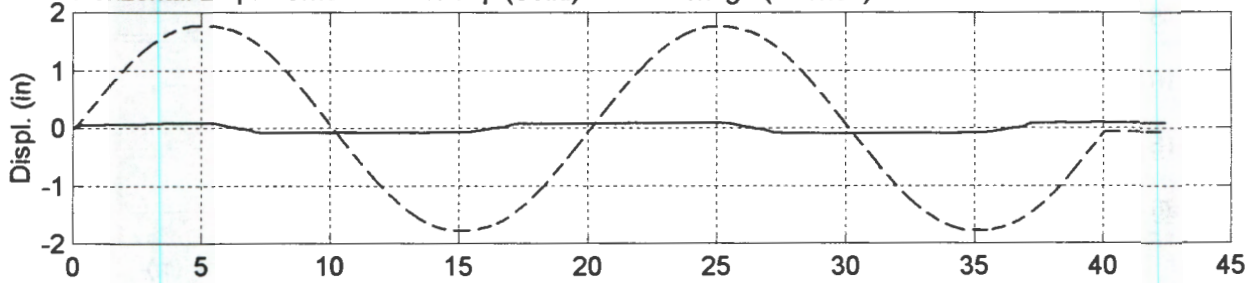

Vertical Displacement, Panel Top: Left (Solid) and Right (Dashed)

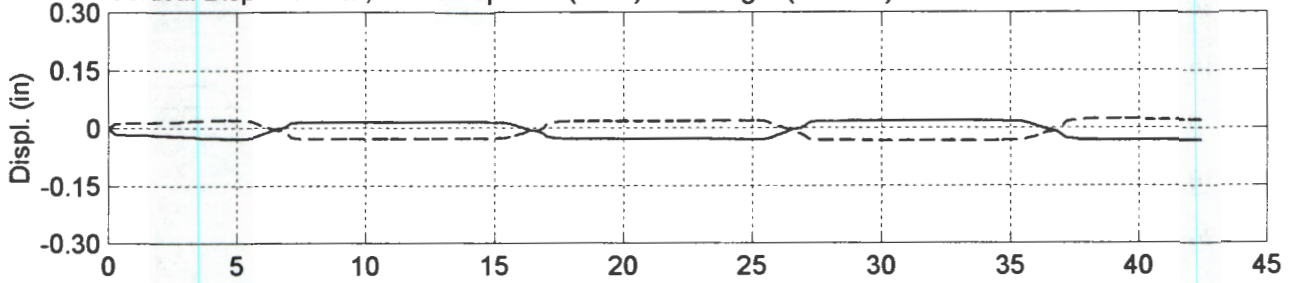

Rel. Ver. Displ.: Panel vs. Right Support (Solid) and Panel (Dotted) and Stud (Dashed) vs. Left Support

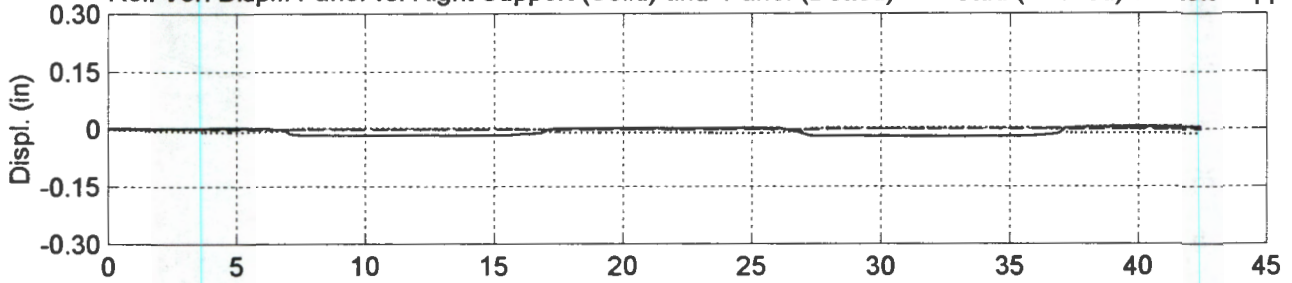

Out of Plane Displacement, Panel Top: Left (Solid) and Right (Dashed)

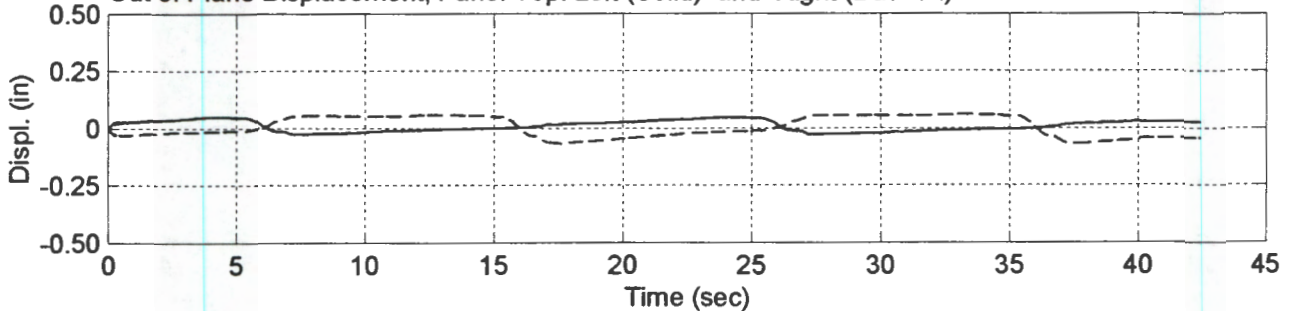

UCR Rivera Library--Test No. 14 Anchorage B Three Devices (T=50 ft-lbs)
Harmonic Motion (0.05 Hz, 1.8 in) File: 06271234.txt

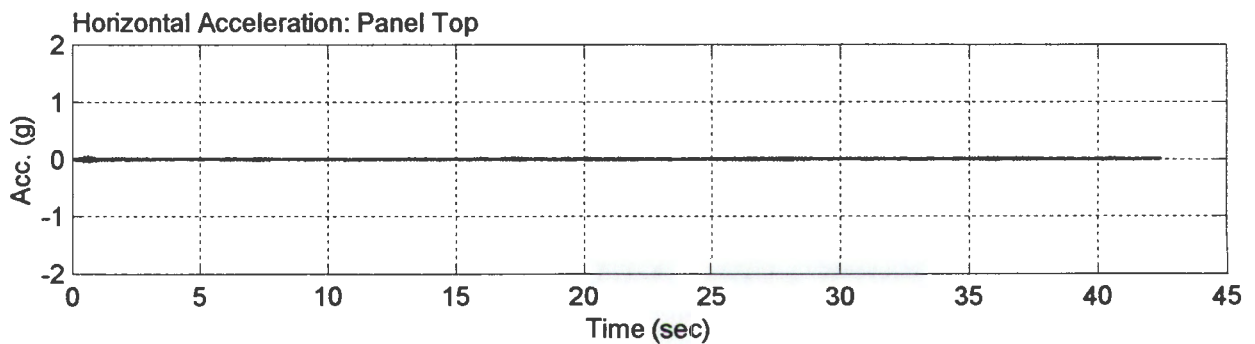
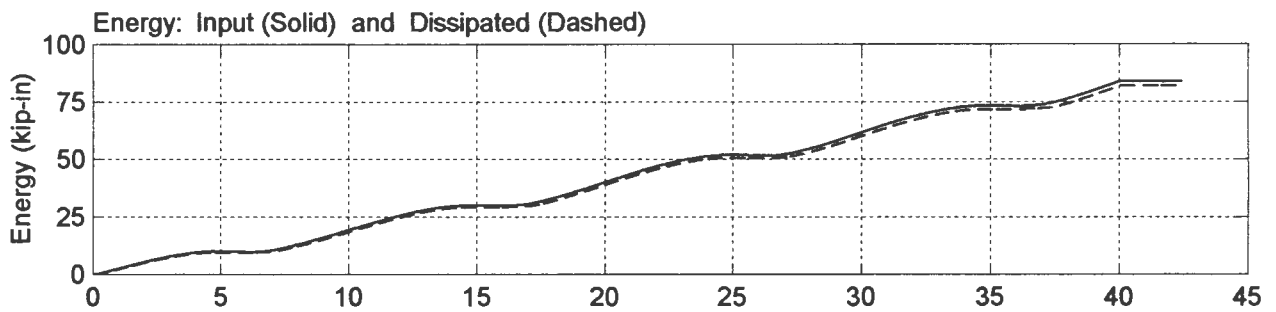
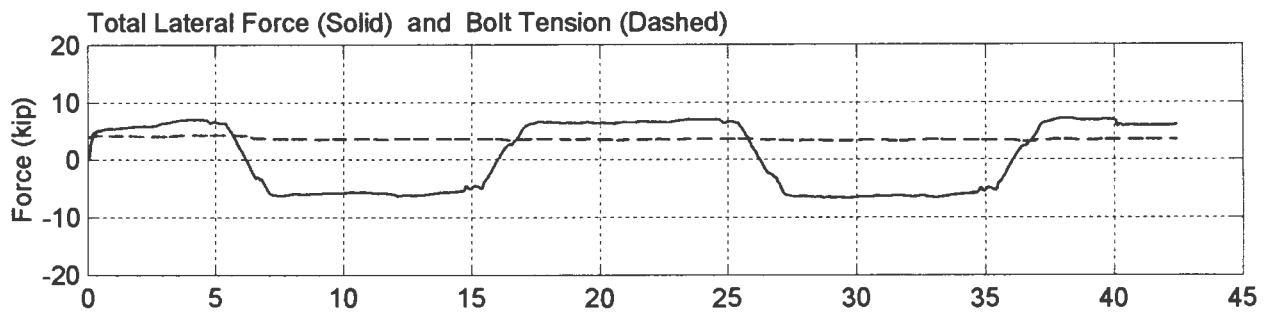
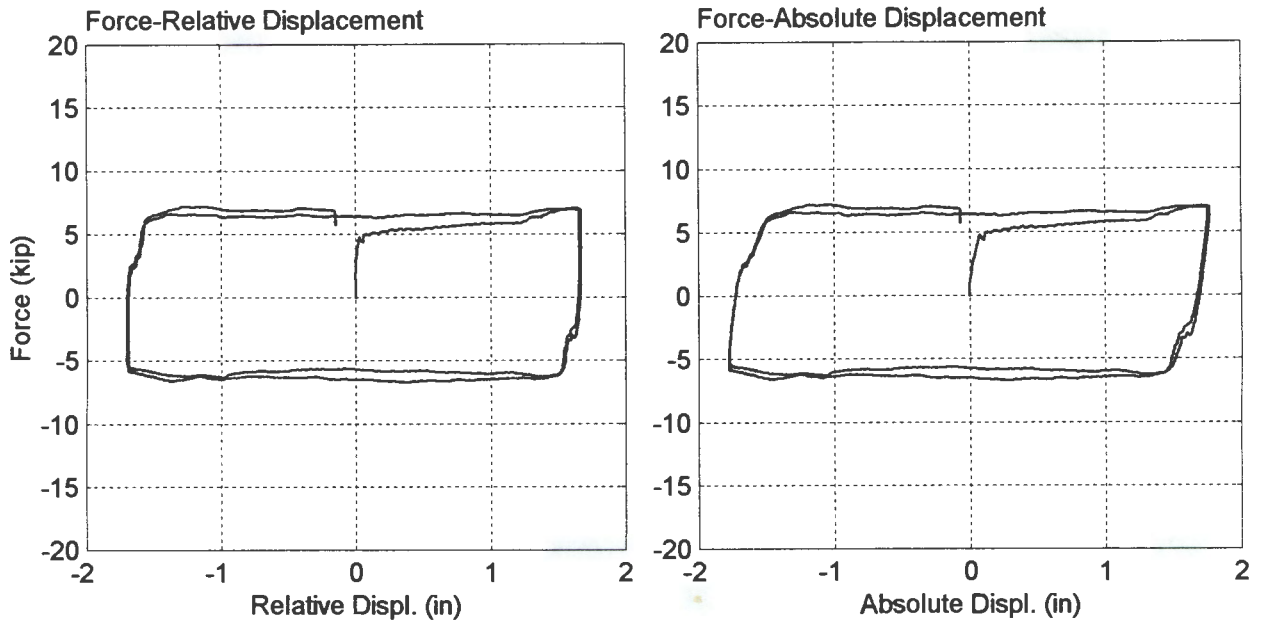

UCR Rivera Library--Test No. 15 Anchorage B Three Devices ($T \approx 100$ ft-lbs)
 Harmonic Motion (0.05 Hz, 1.8 in) File: 06271255.txt

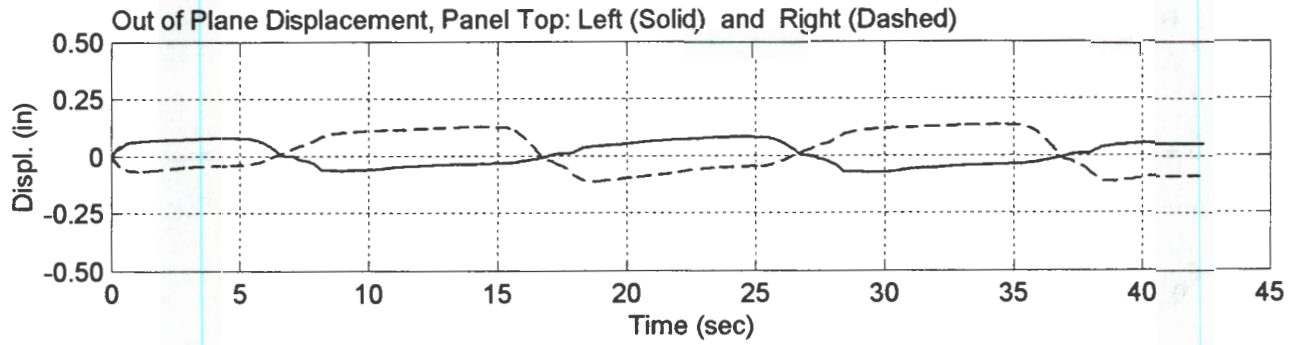
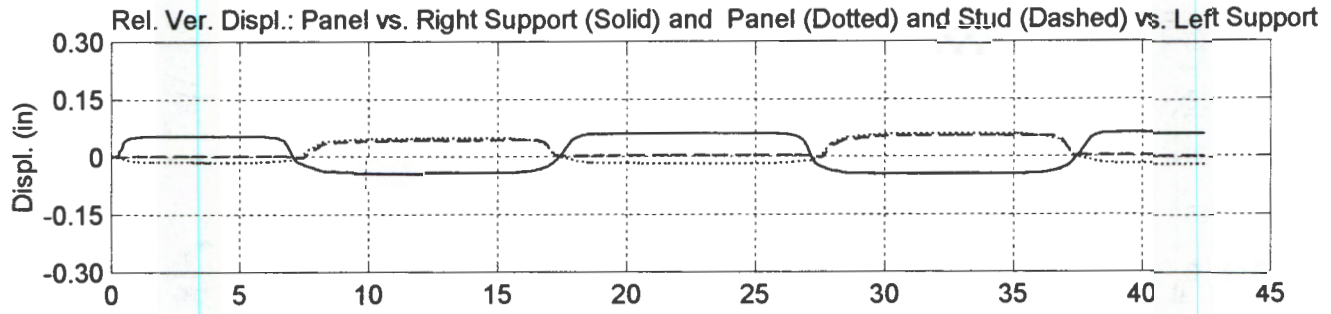
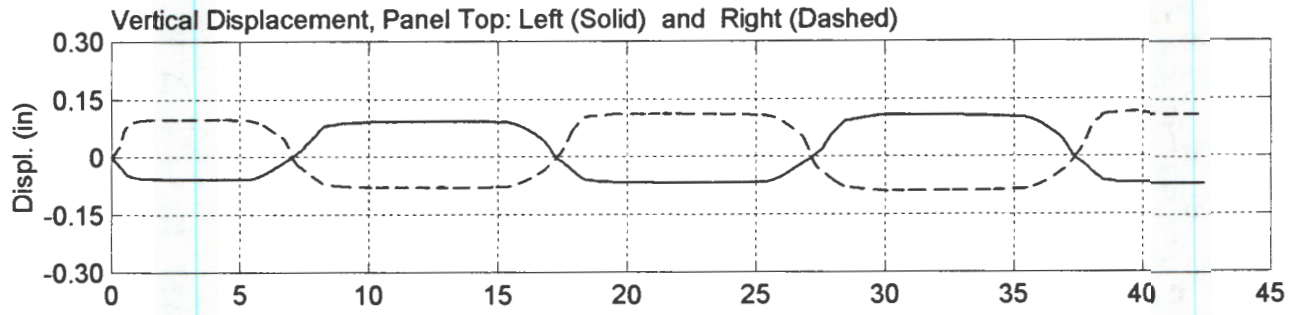
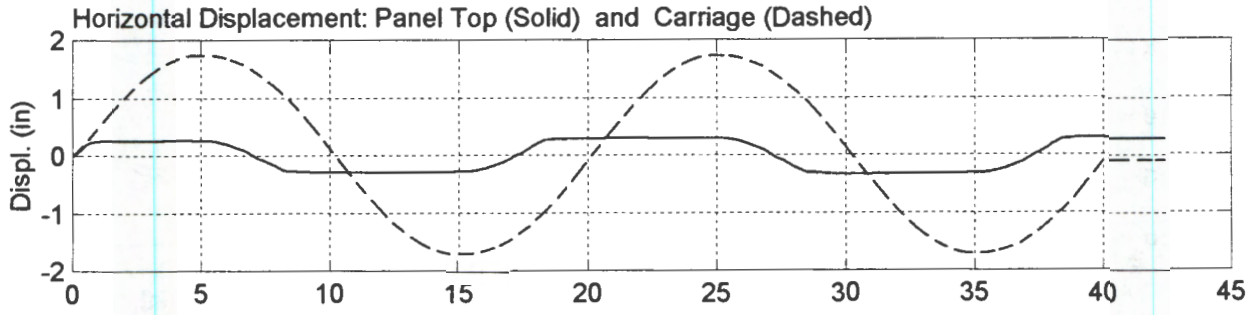
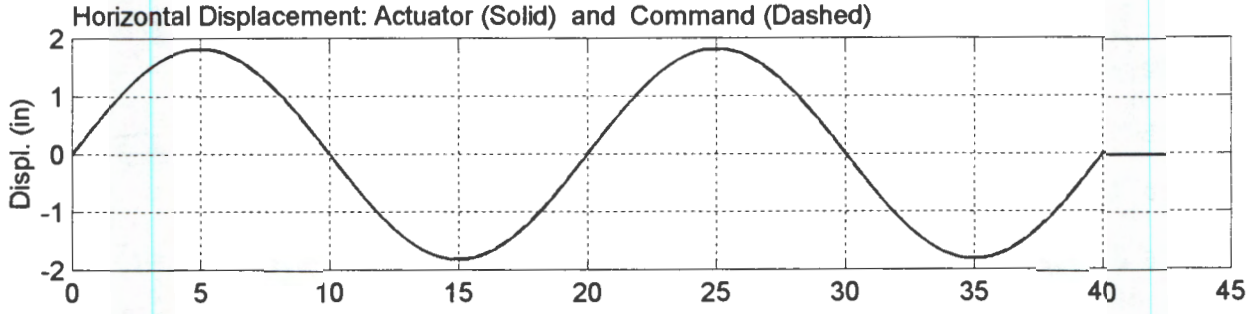

UCR Rivera Library--Test No. 15 Anchorage B Three Devices (T=100 ft-lbs)
Harmonic Motion (0.05 Hz, 1.8 in) File: 06271255.txt

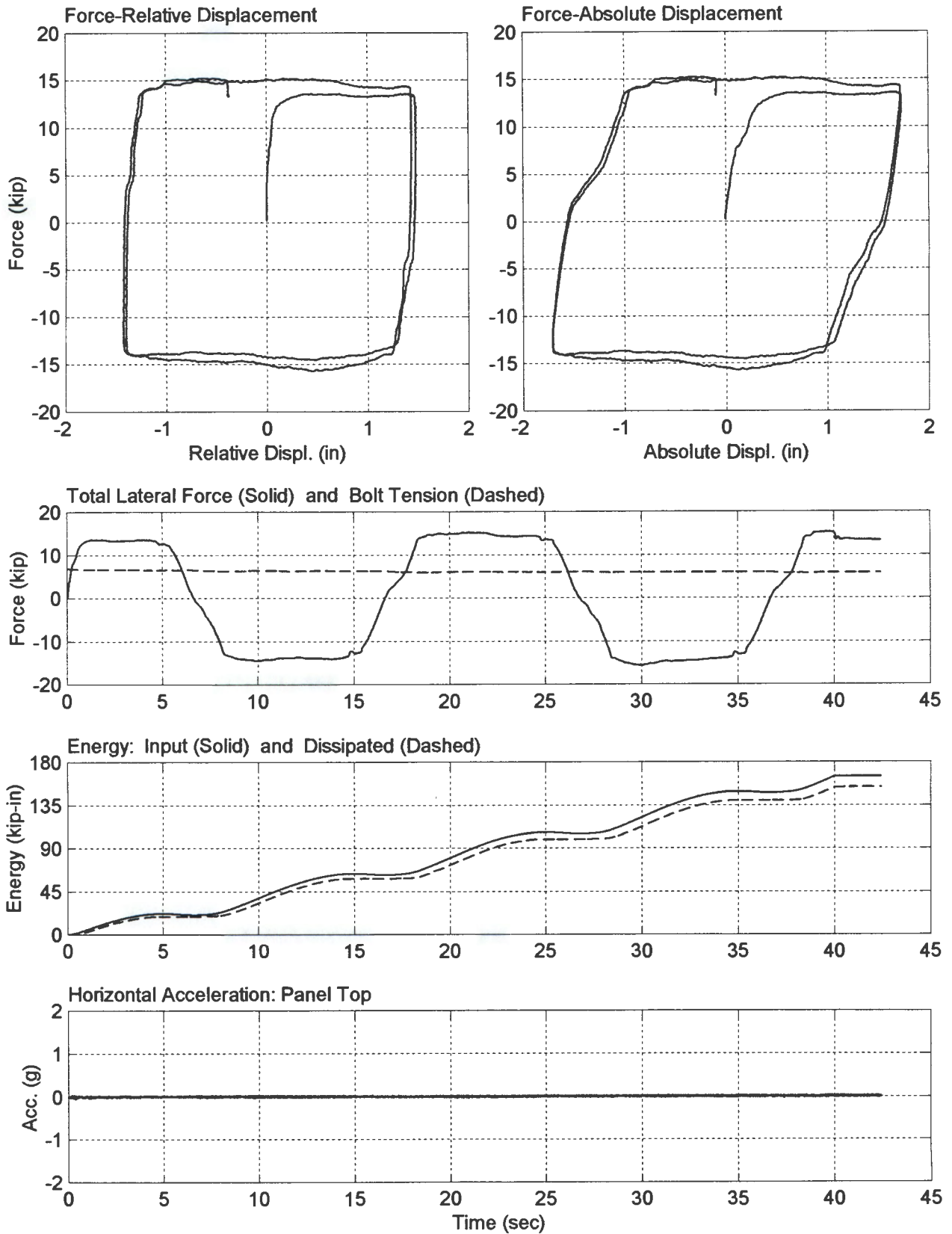

UCR Rivera Library--Test No. 16 Anchorage B Three Devices (T=100 ft-lbs)
Seismic Motion (Max. Ampl.=1.1 in) File: 06271329.txt

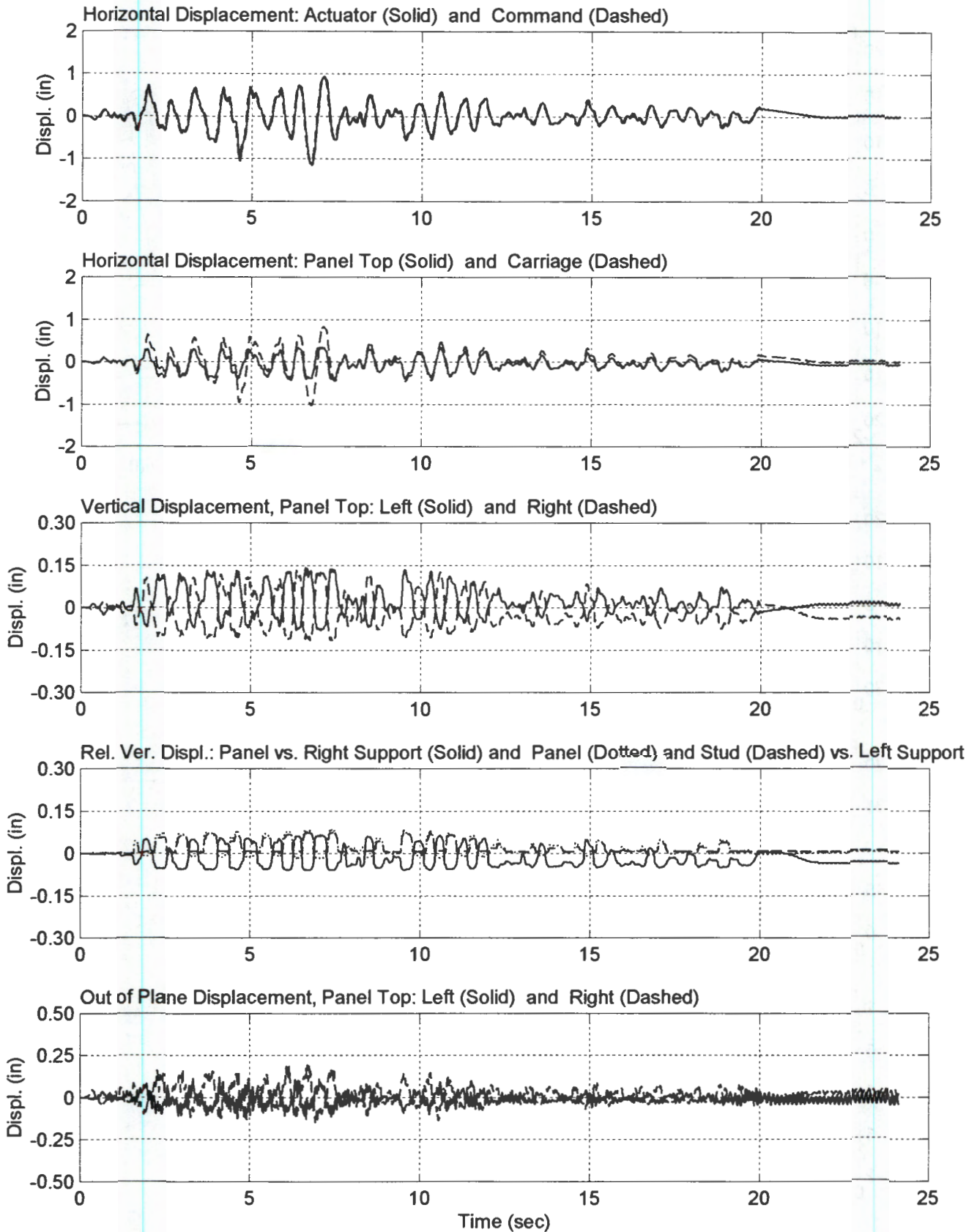

UCR Rivera Library--Test No. 16 Anchorage B Three Devices (T=100 ft-lbs)
Seismic Motion (Max. Ampl.=1.1 in) File: 06271329.txt

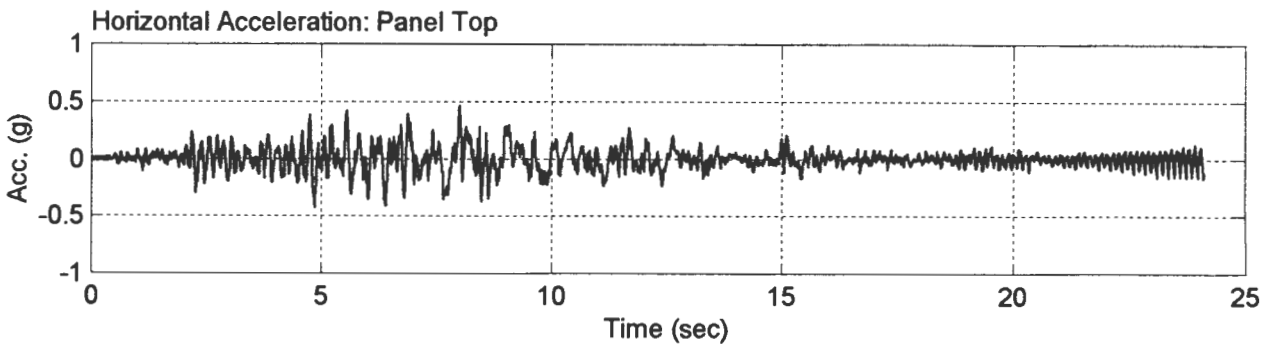
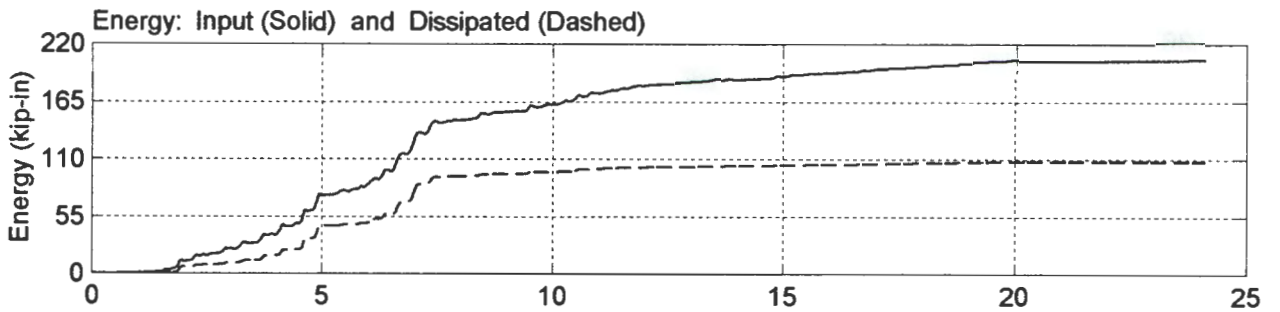
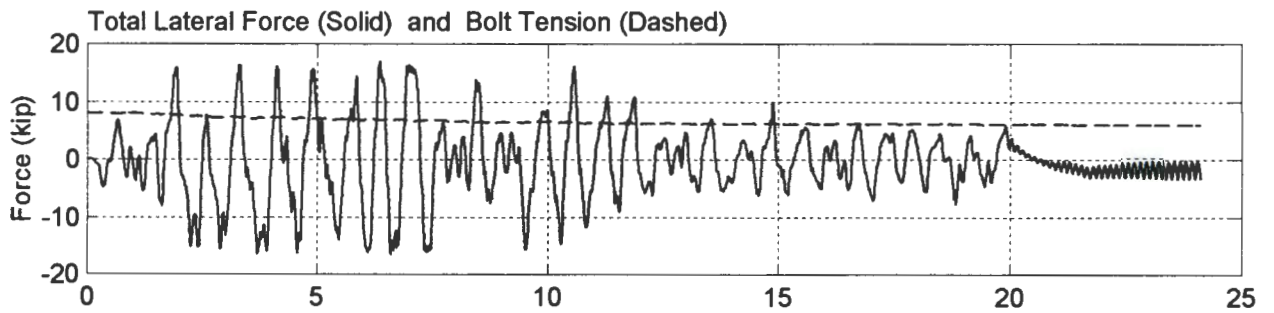
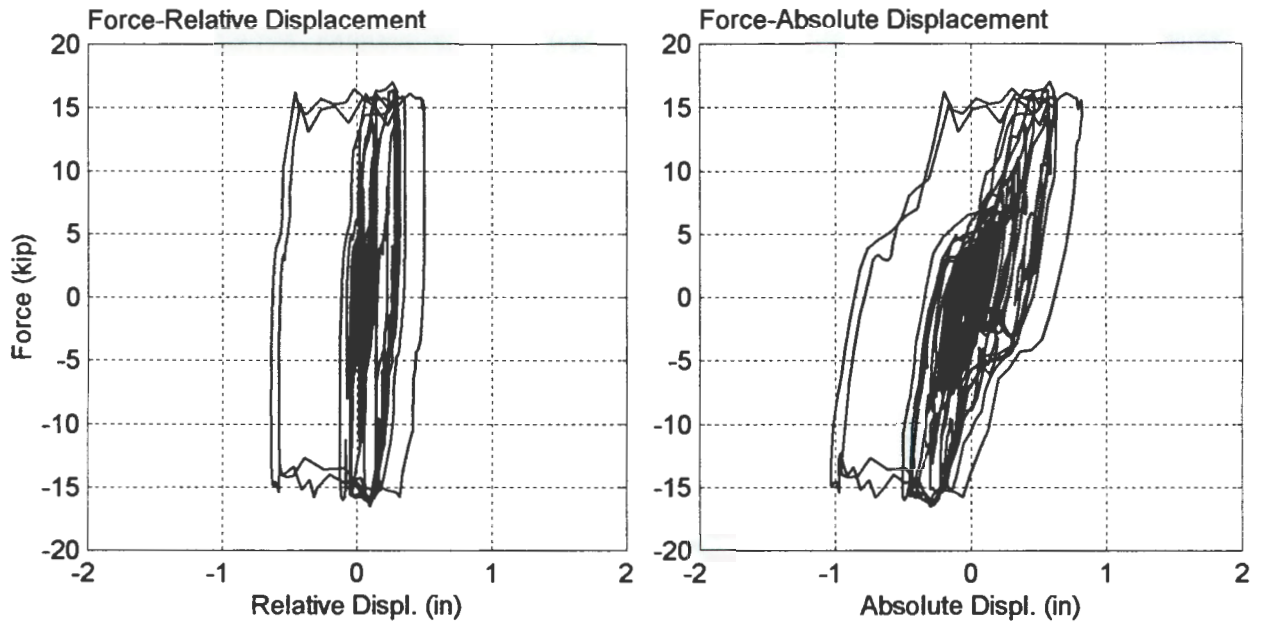

UCR Rivera Library--Test No. 17 Anchorage B Three Devices (T=100 ft-lbs)
Seismic Motion (Max. Ampl.=1.65 in) File: 06271349.txt

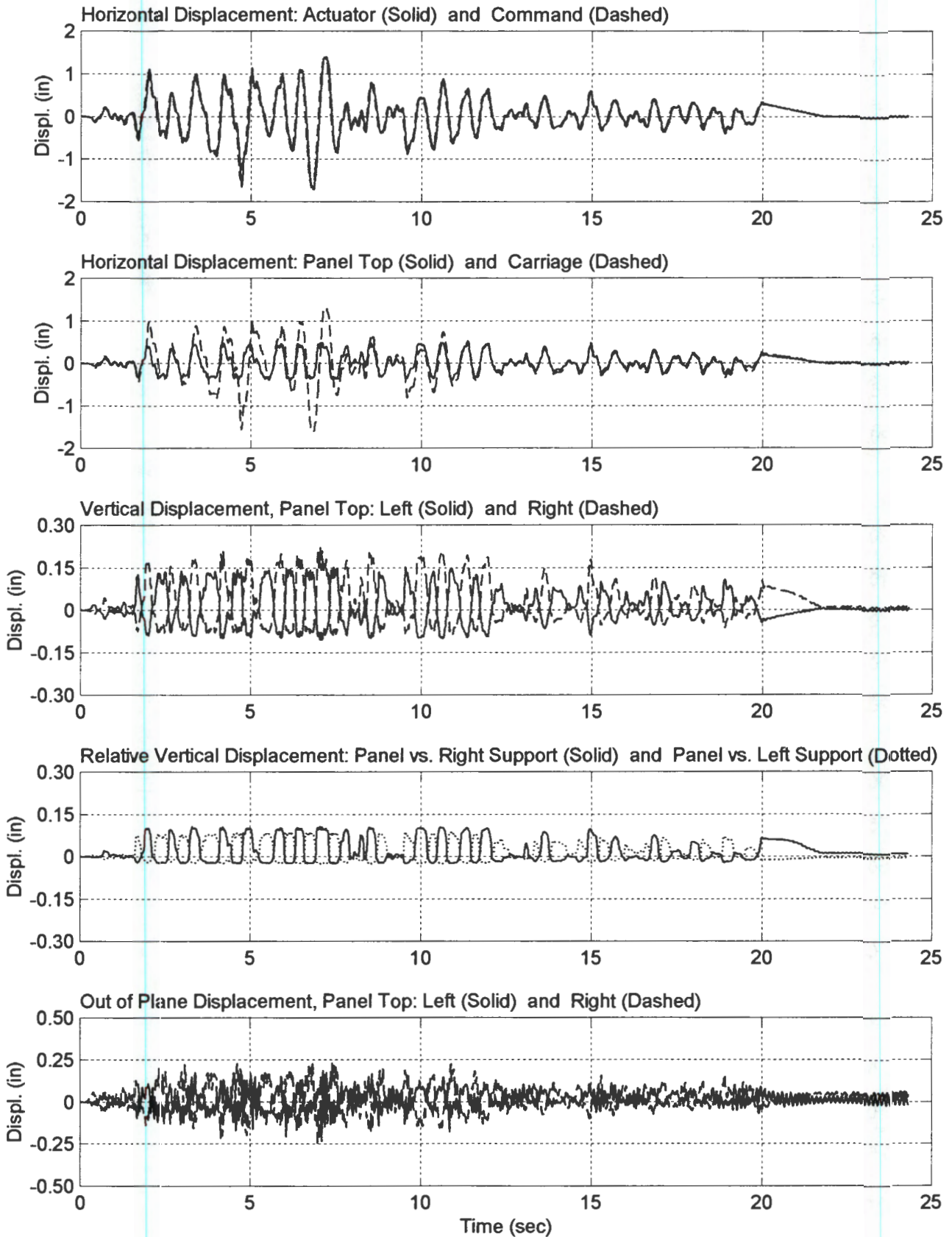

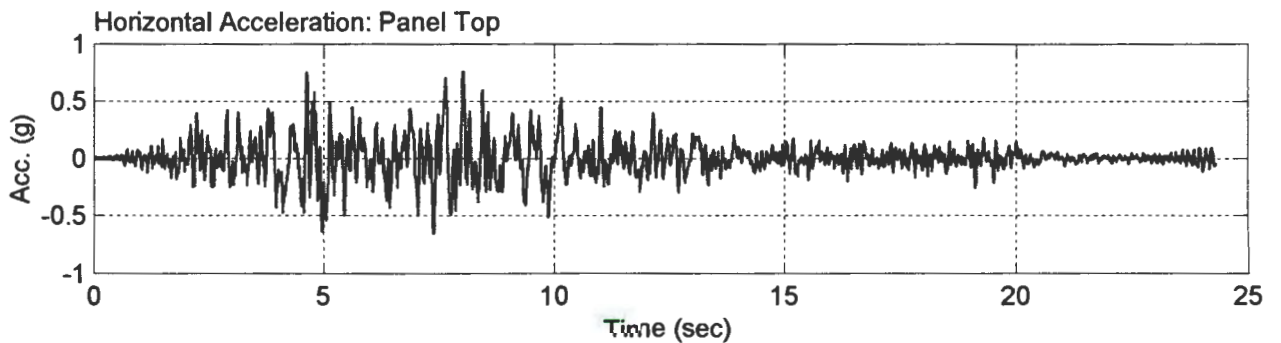
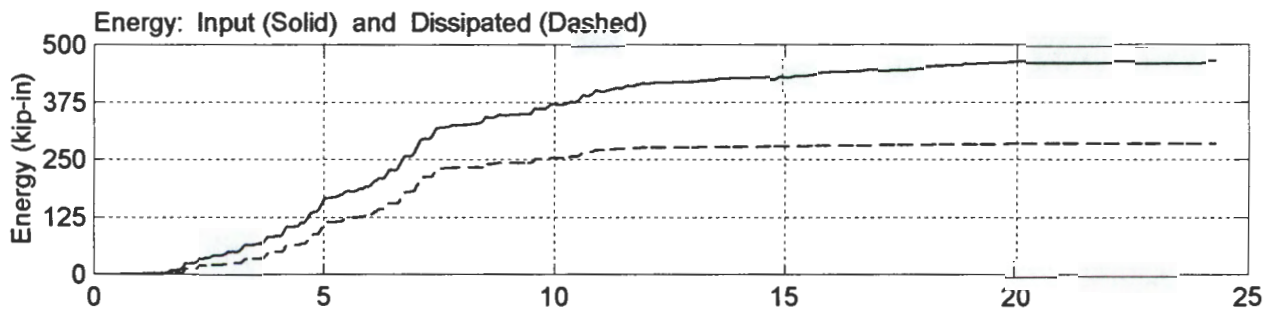
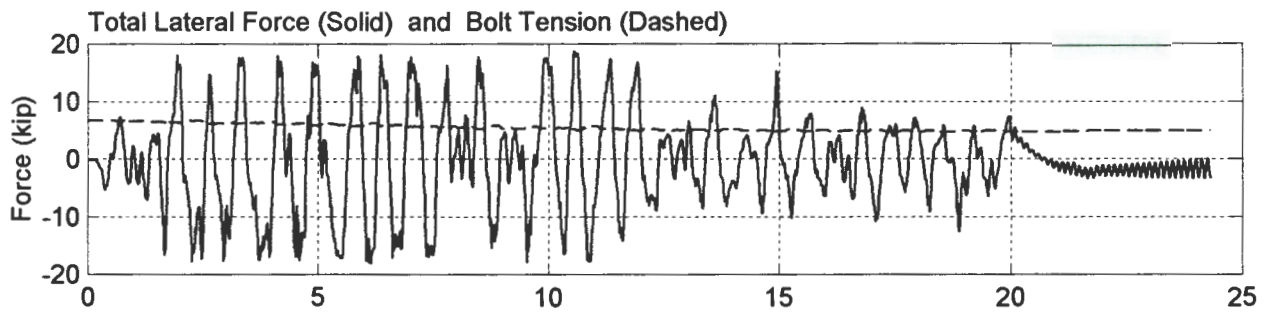
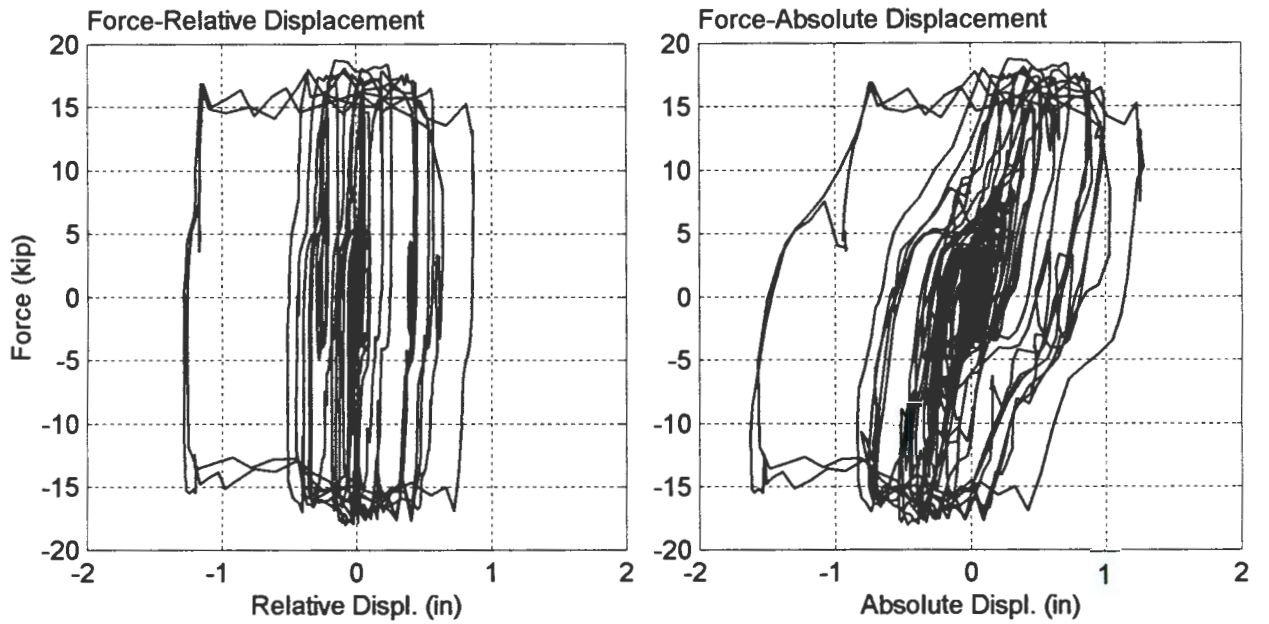

UCR Rivera Library--Test No. 18 Anchorage B Three Devices (T=100 ft-lbs)
Harmonic Motion (1.5 Hz, 1.8 in) File: 06271410.txt

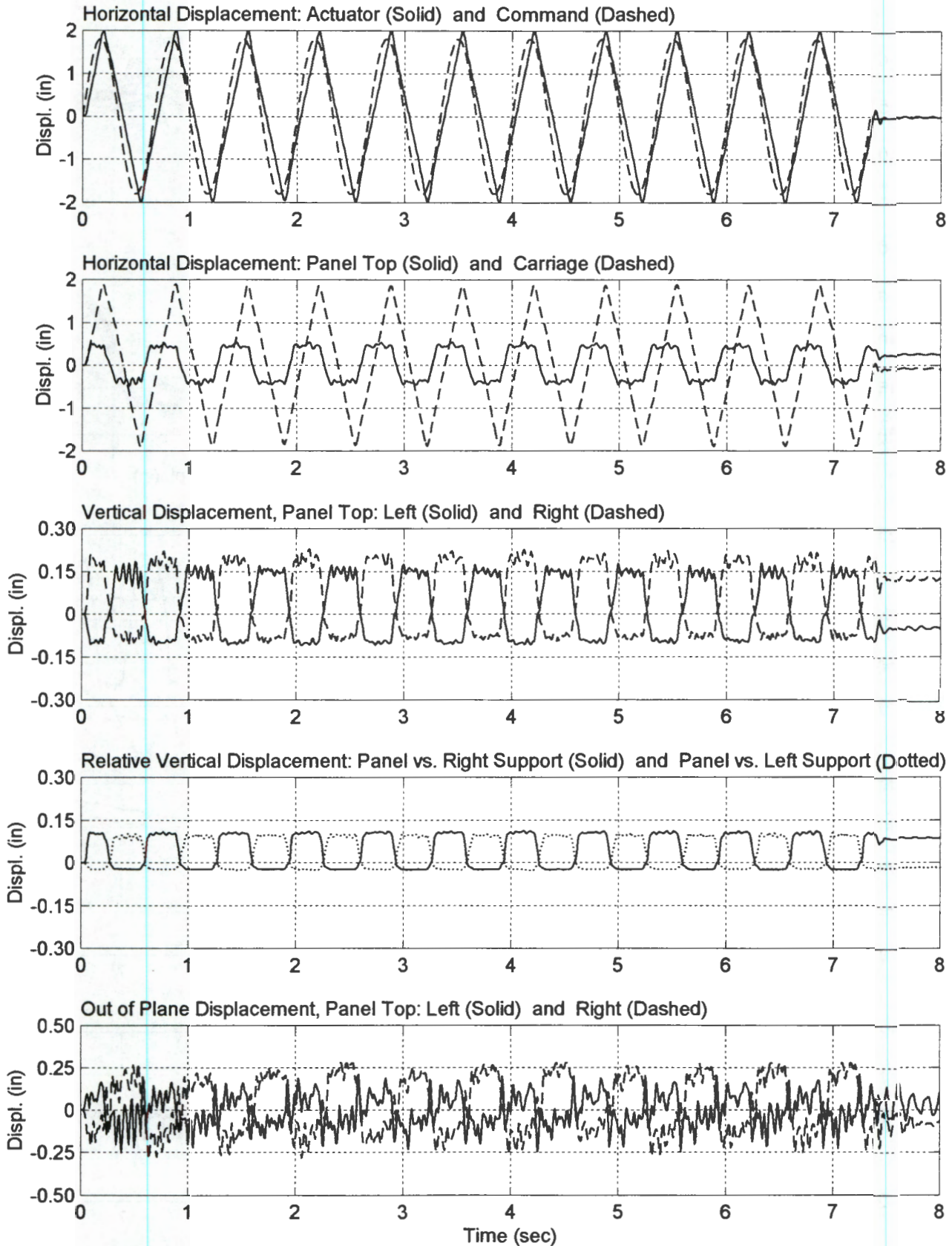

UCR Rivera Library--Test No. 18 Anchorage B Three Devices (T=100 ft-lbs)
Harmonic Motion (1.5 Hz, 1.8 in) File: 06271410.txt

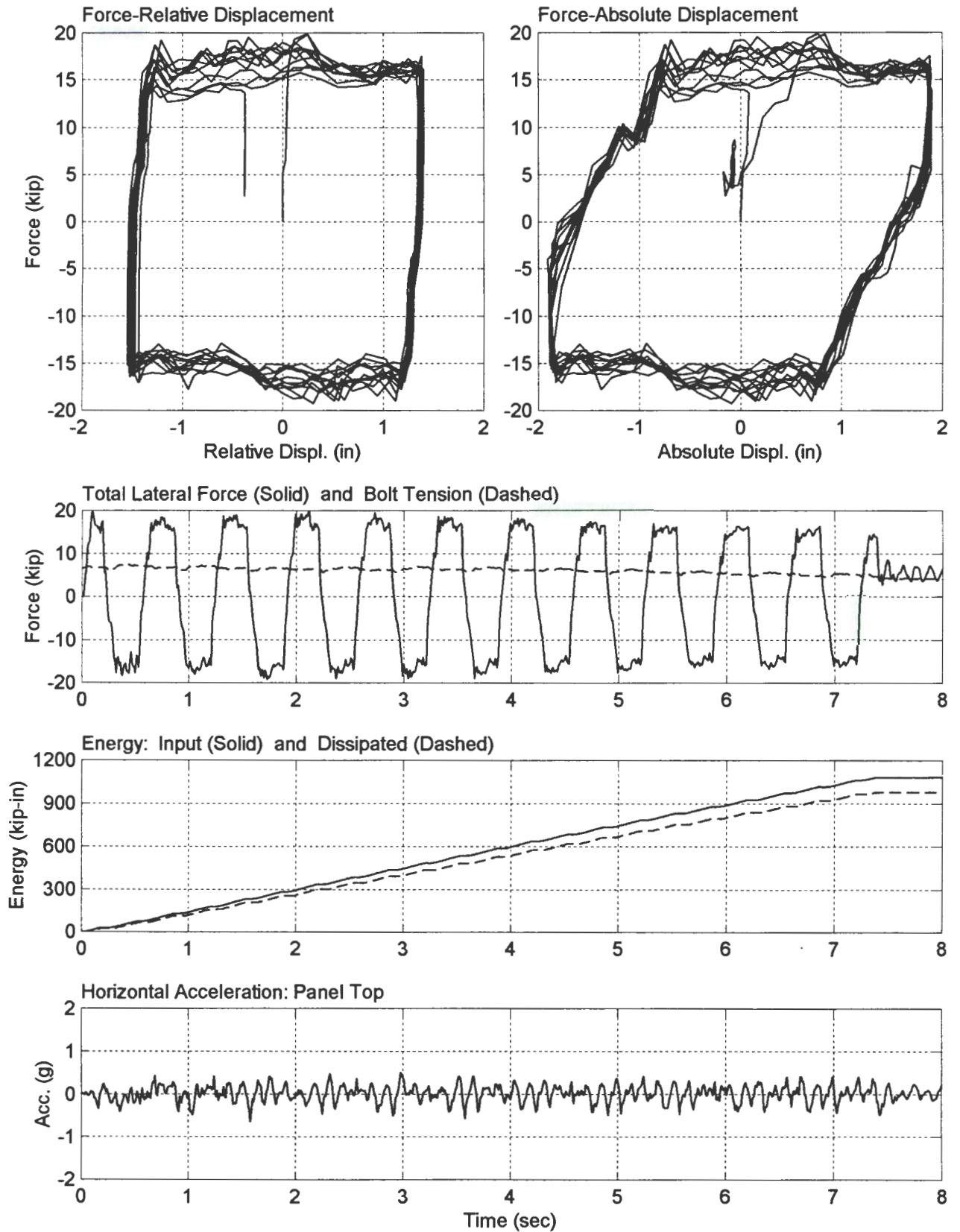

UCR Rivera Library--Test No. 19 Anchorage B Three Devices (T=100 ft-lbs)
Harmonic Motion (1.5 Hz, 0.5 in) File: 06271435.txt

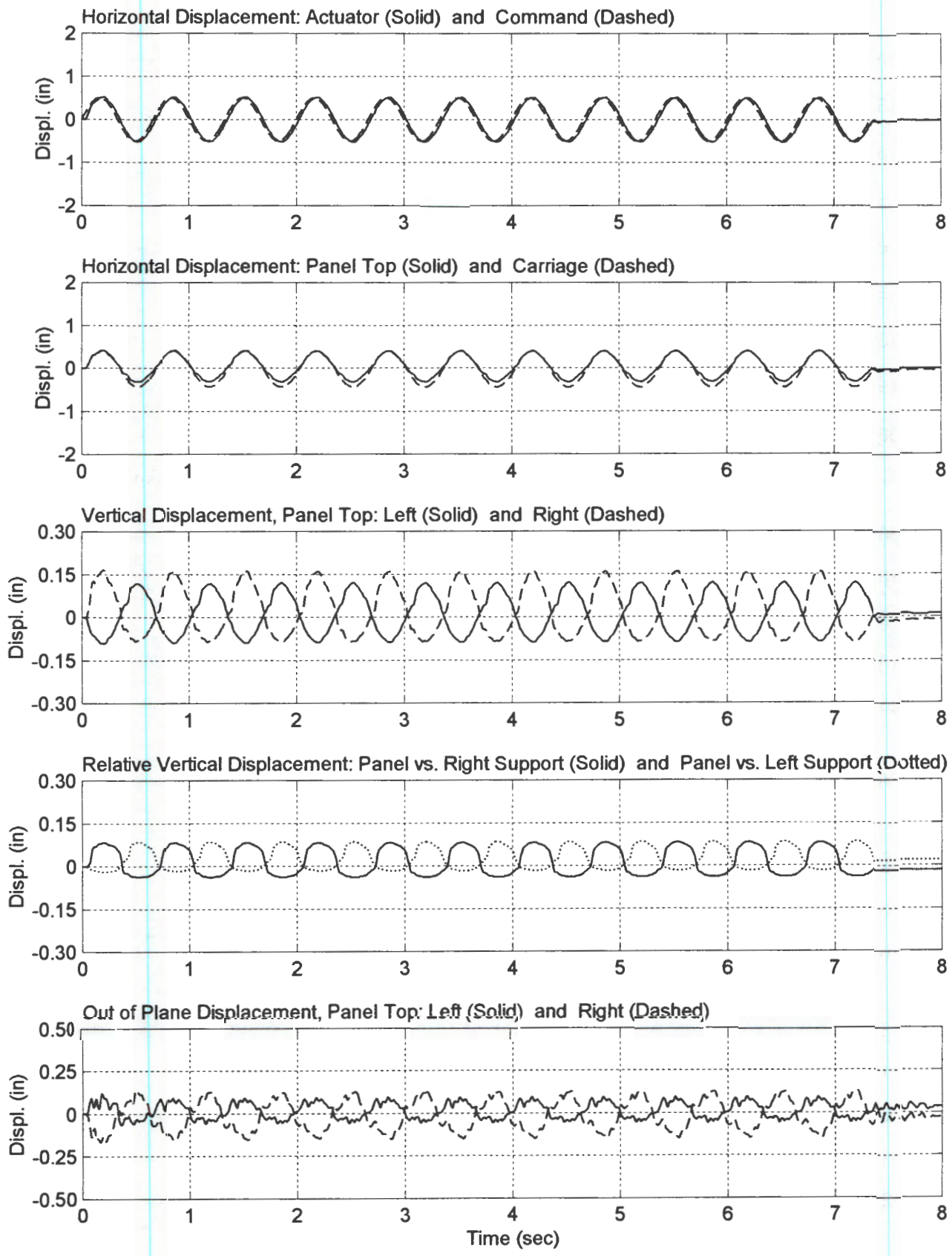

UCR Rivera Library--Test No. 19 Anchorage B Three Devices (T=100 ft-lbs)
Harmonic Motion (1.5 Hz, 0.5 in) File: 06271435.txt

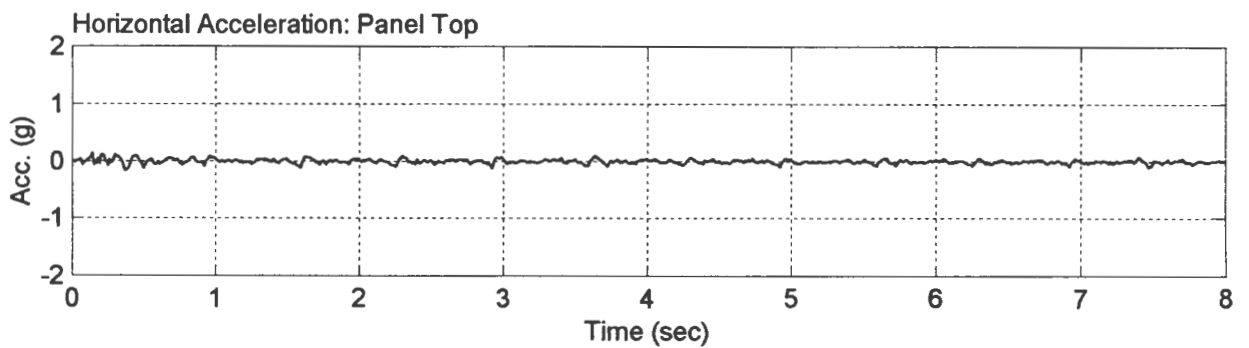
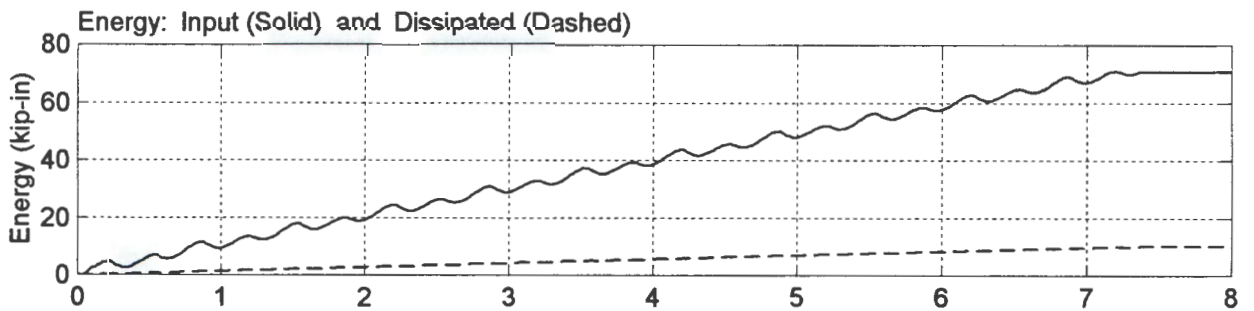
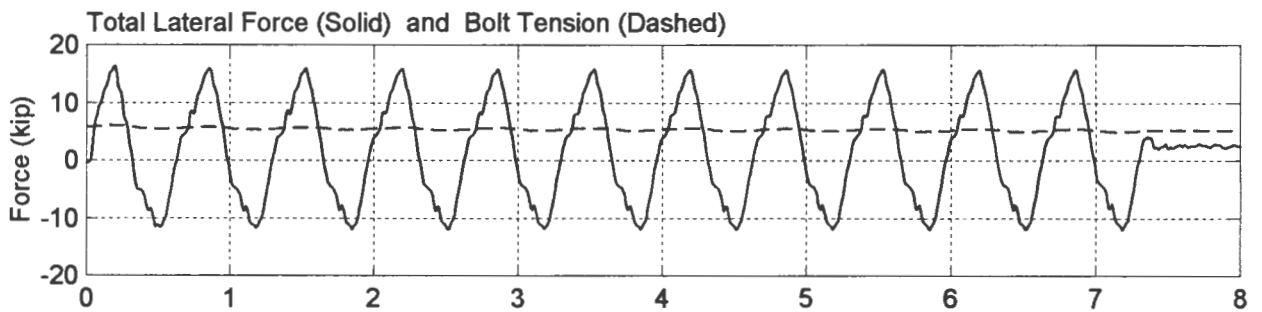
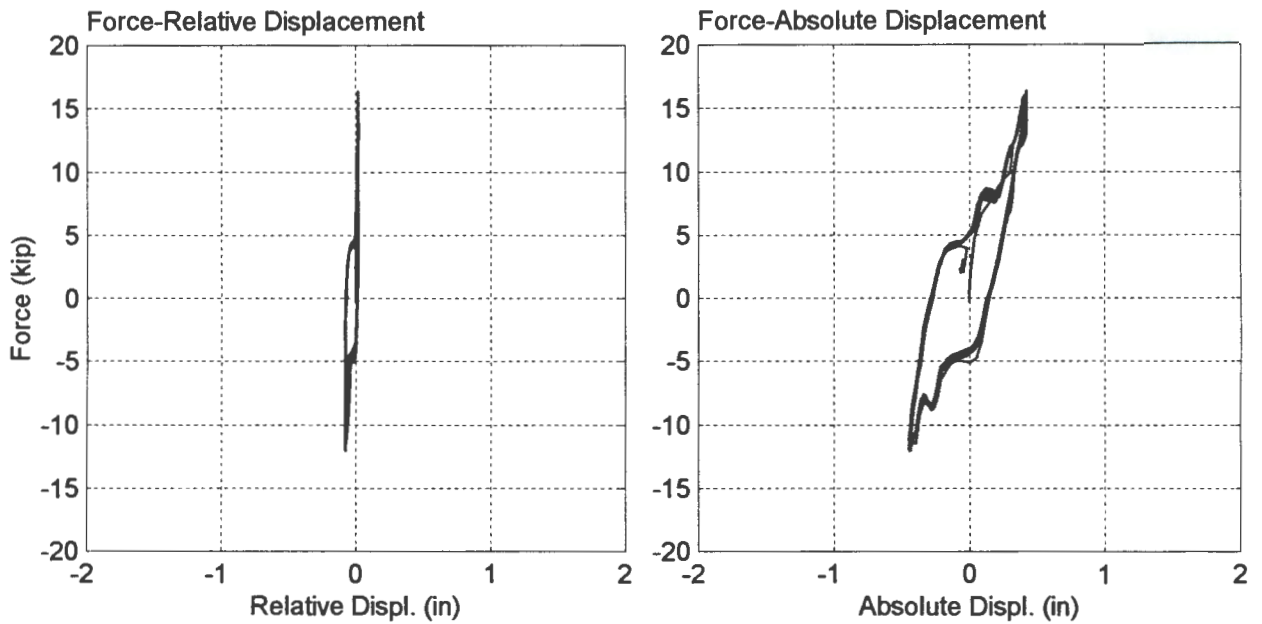

UCR Rivera Library--Test No. 20 Anchorage B Three Devices (T=100 ft-lbs)
Harmonic Motion (1.5 Hz, 1.8 in) File: 06271440.txt

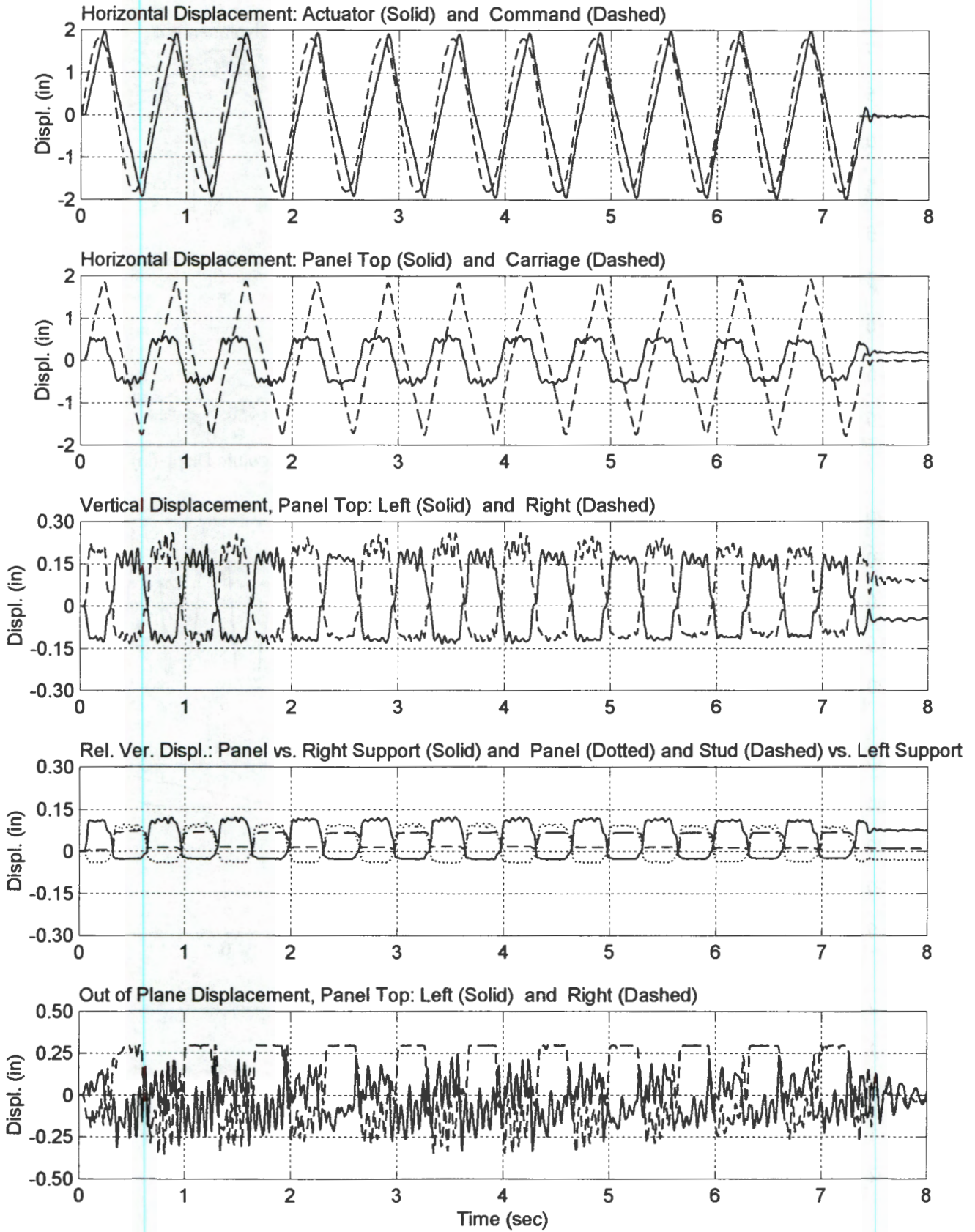

UCR Rivera Library--Test No. 20 Anchorage B Three Devices (T=100 ft-lbs)
Harmonic Motion (1.5 Hz, 1.8 in) File: 06271440.txt

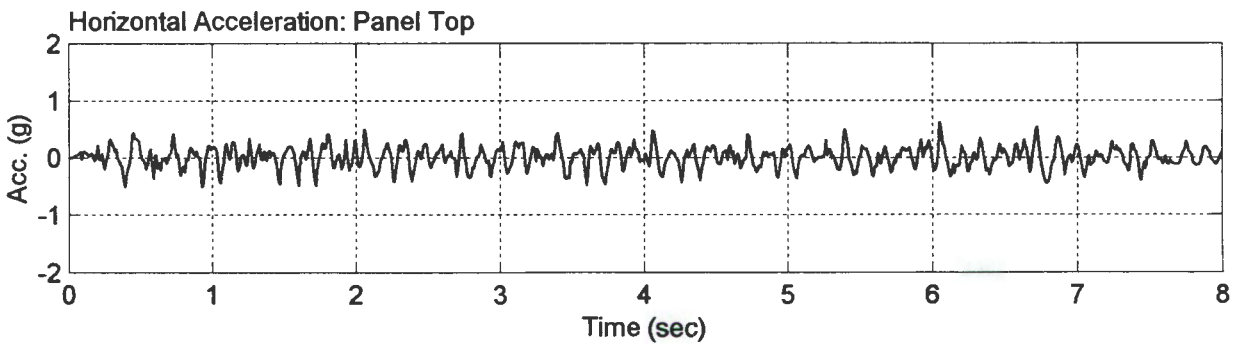
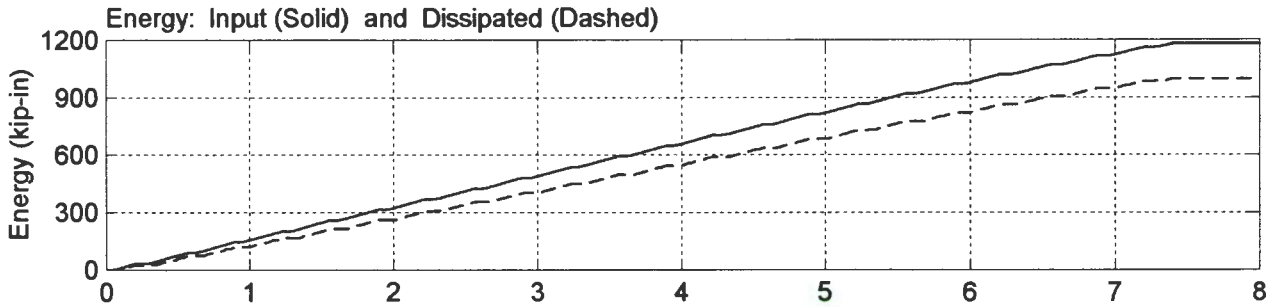
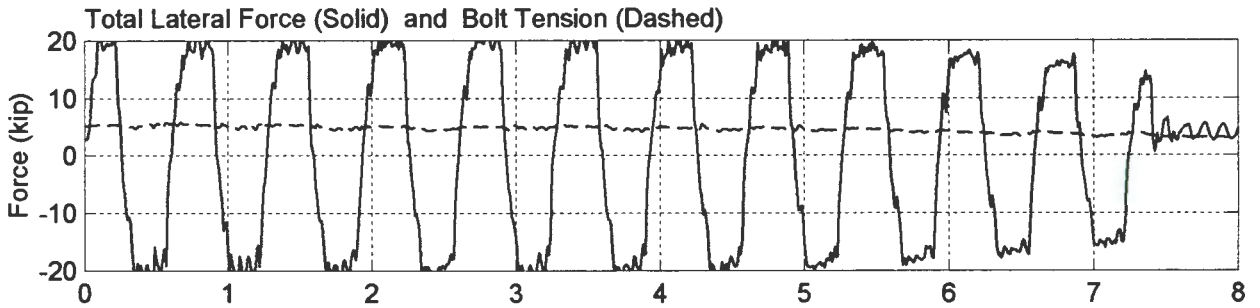
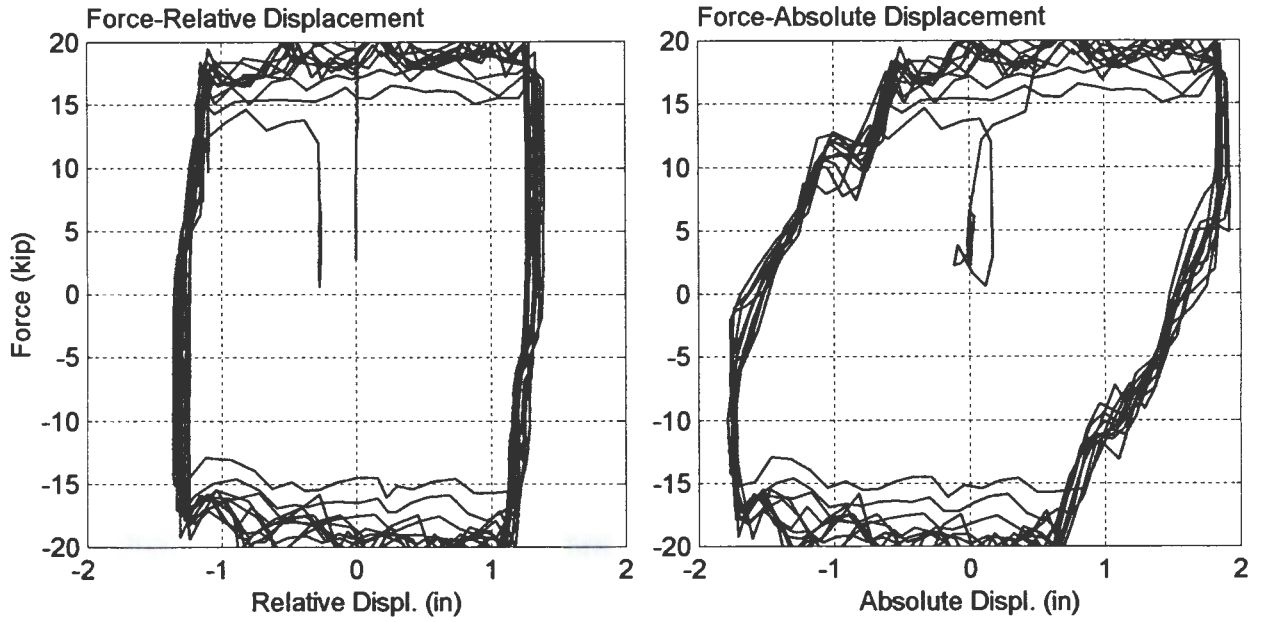

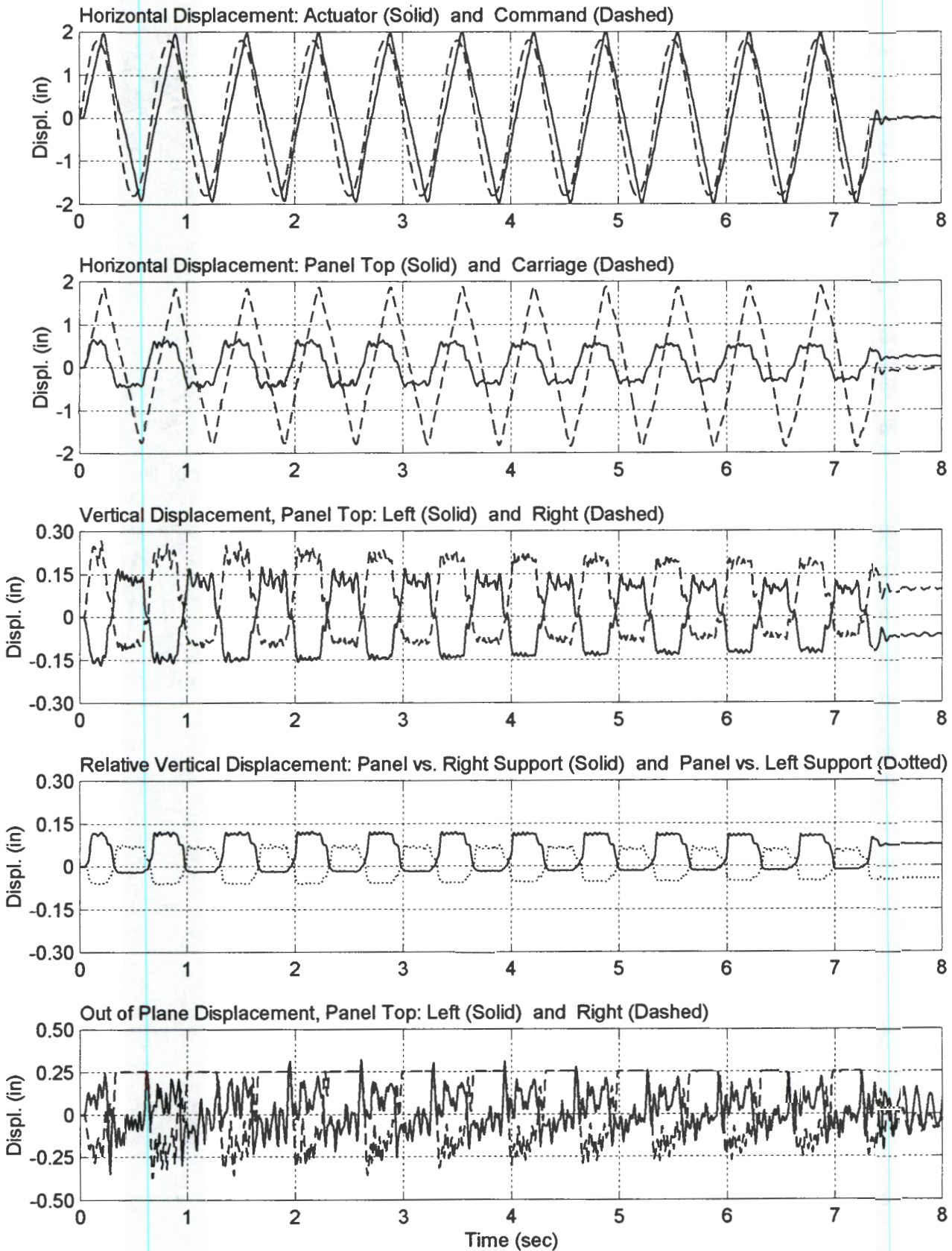

UCR Rivera Library--Test No. 21 Anchorage B Three Devices (T=100 ft-lbs)
Harmonic Motion (1.5 Hz, 1.8 in) File: 06271509.txt

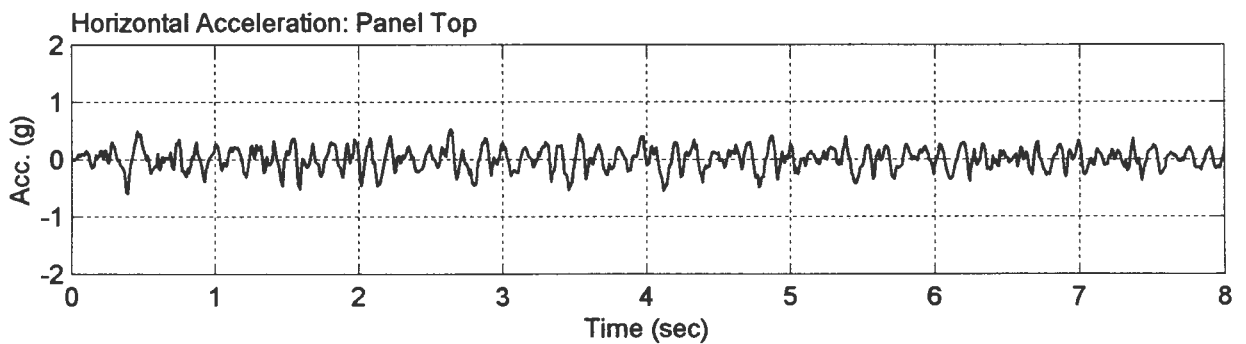
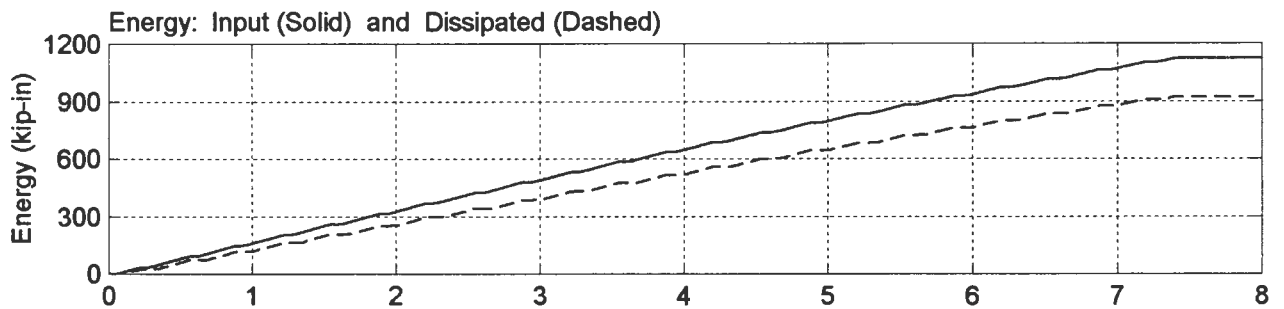
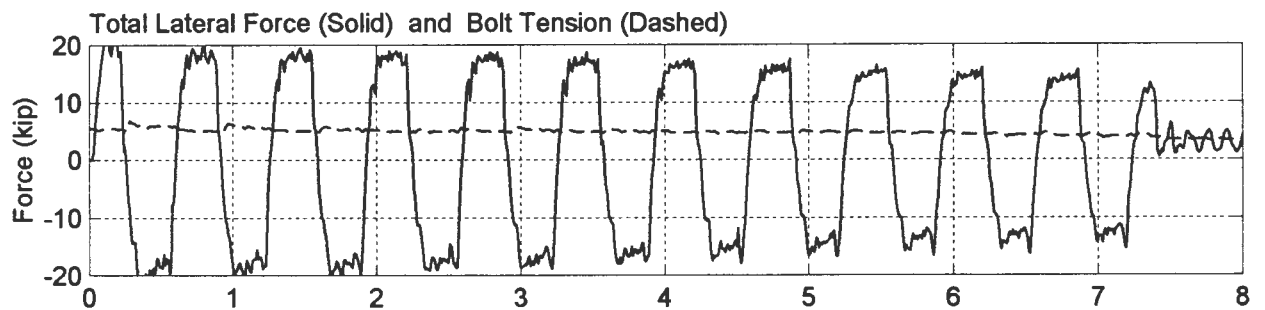
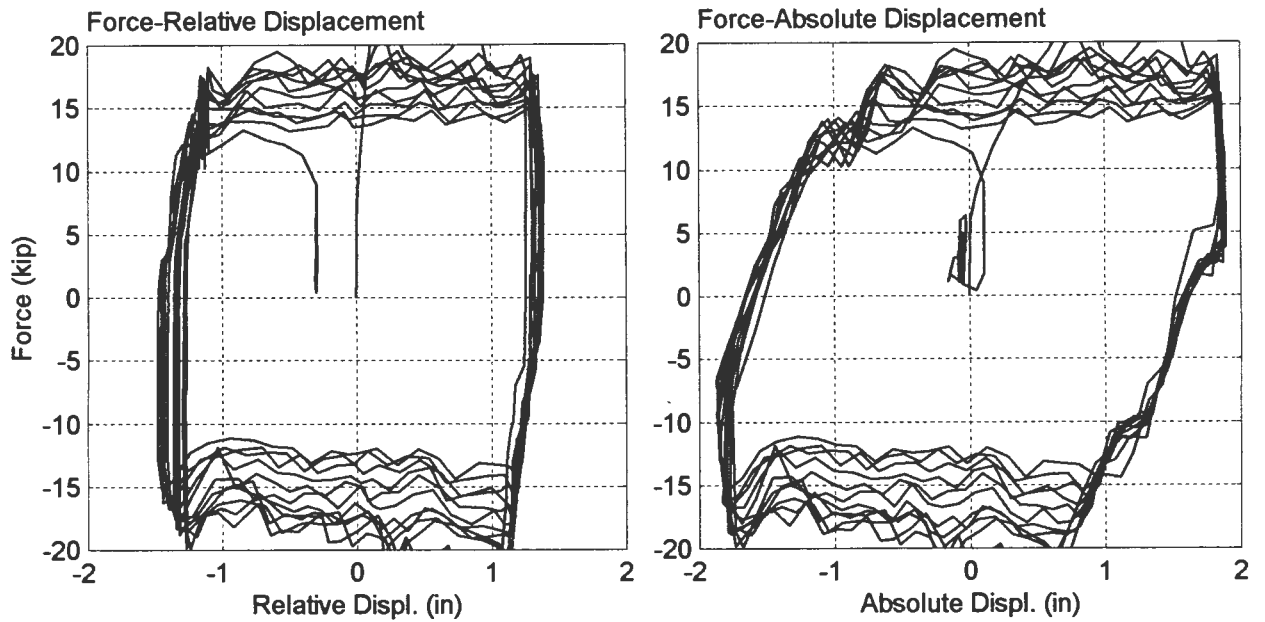

UCR Rivera Library--Test No. 22 Anchorage B Three Devices (T=150 ft-lbs)
Harmonic Motion (1.5 Hz, 1.8 in) File: 06271531.txt

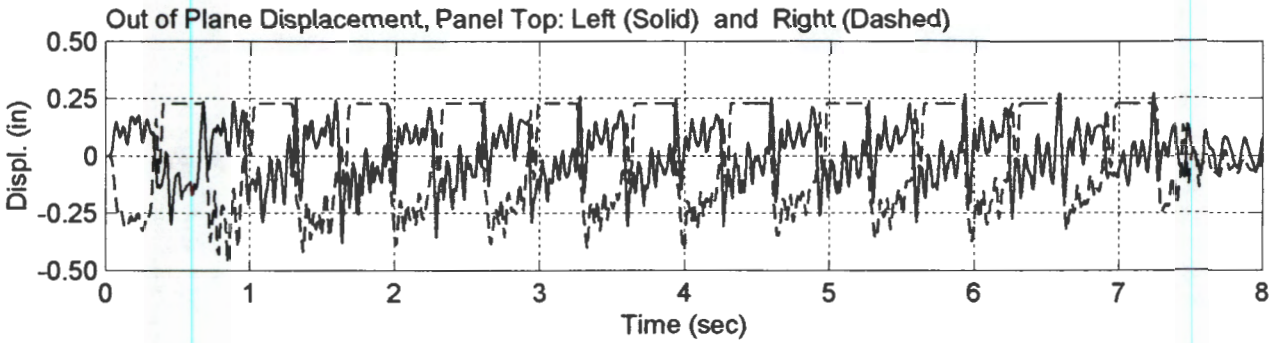
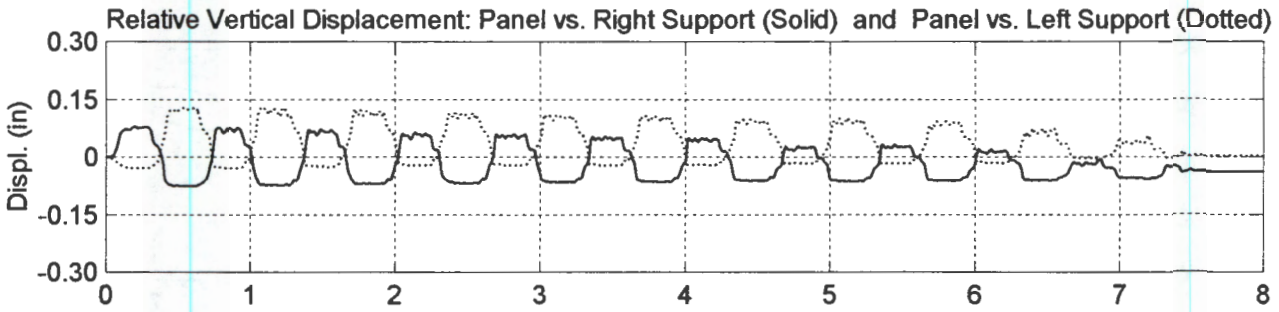
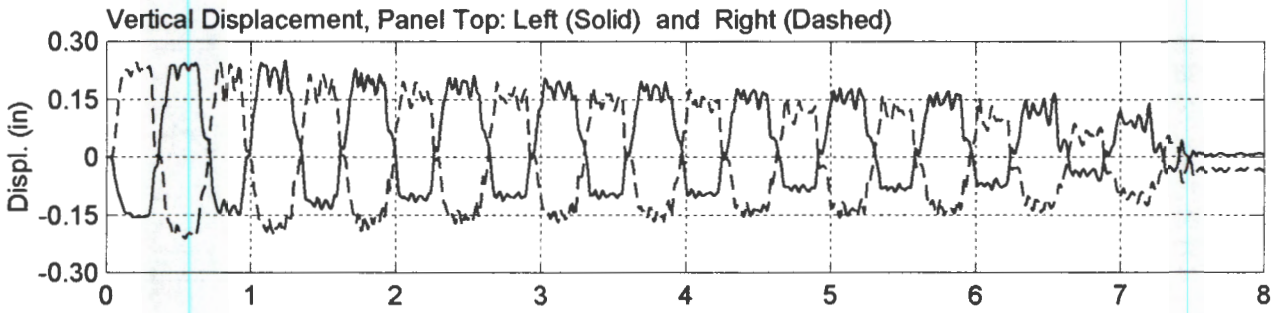
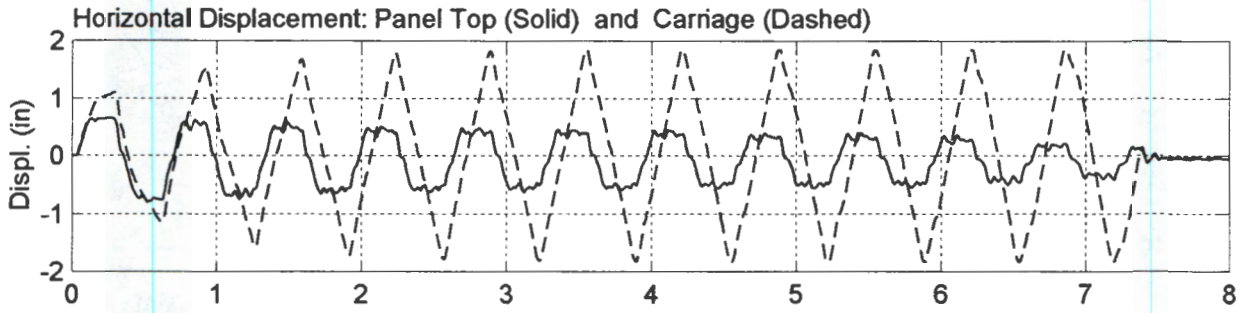
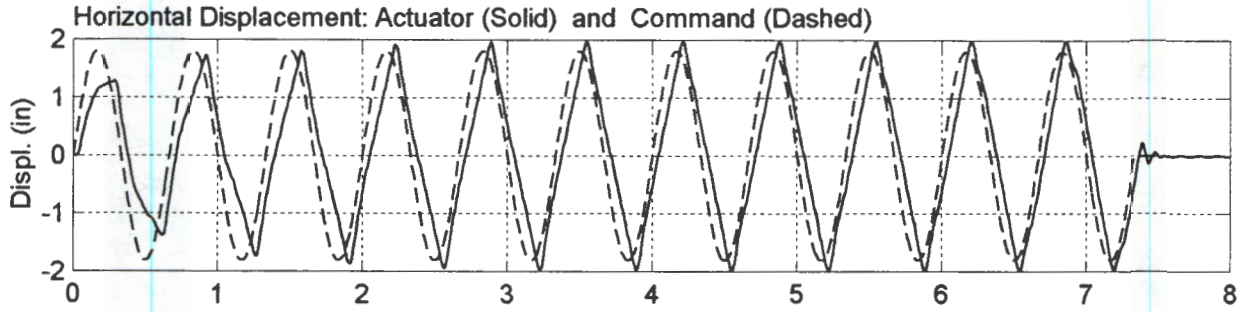

UCR Rivera Library--Test No. 22 Anchorage B Three Devices (T=150 ft-lbs)
Harmonic Motion (1.5 Hz, 1.8 in) File: 06271531.txt

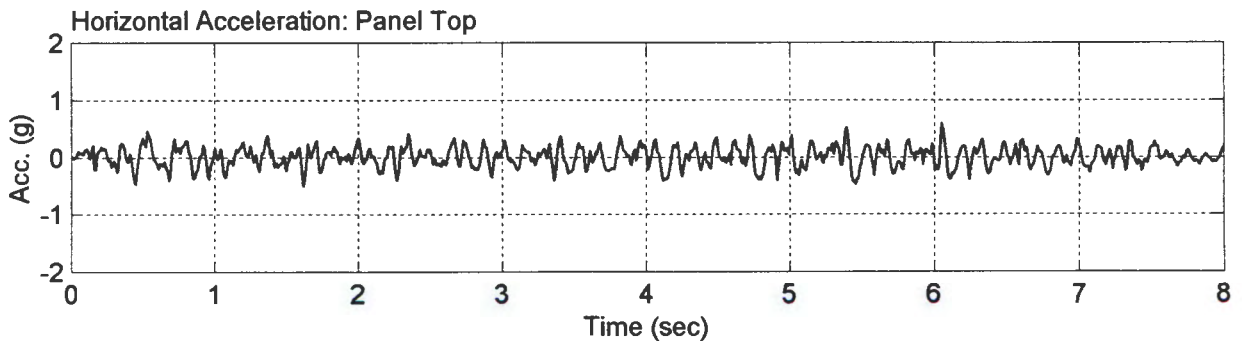
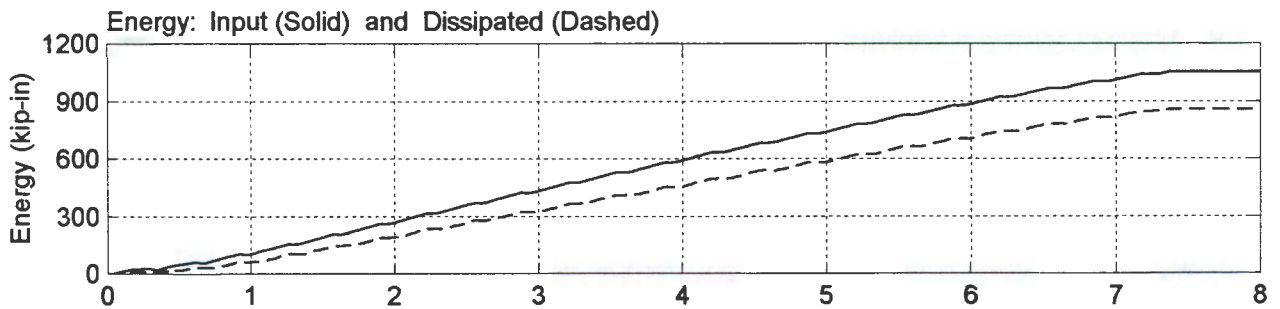
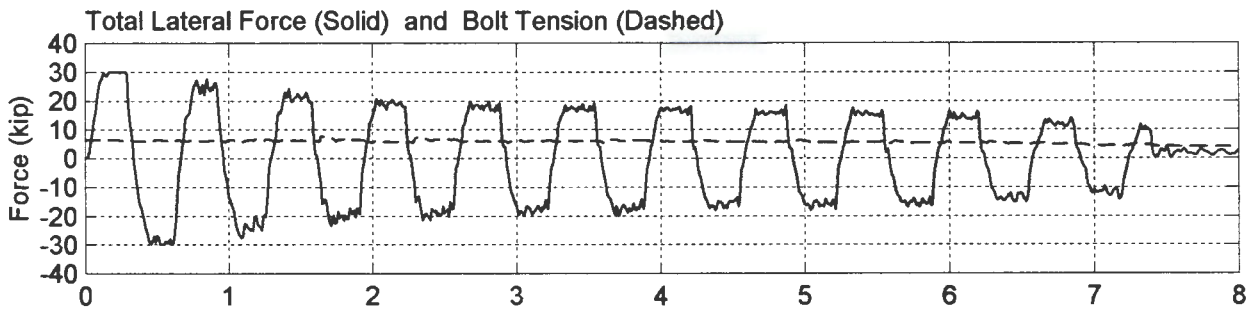
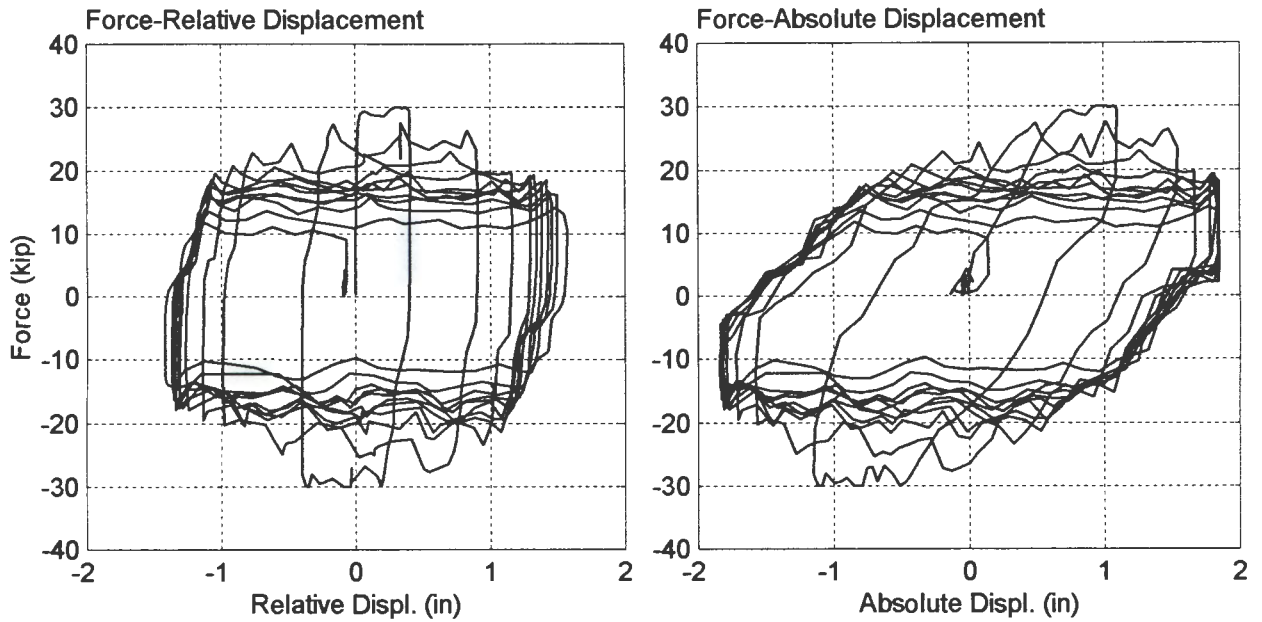

UCR Rivera Library--Test No. 23 Anchorage B Three Devices (T=200 ft-lbs)

Harmonic Motion (1.5 Hz, 1.8 in) File: 06271553.txt

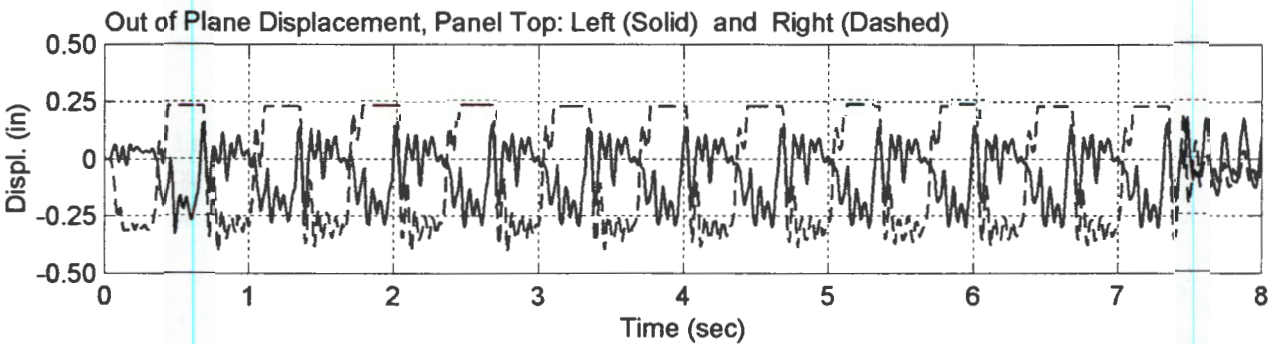
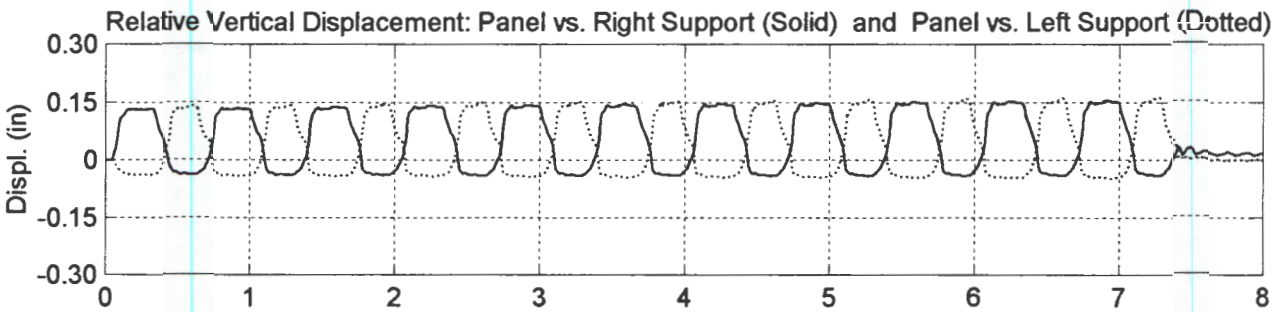
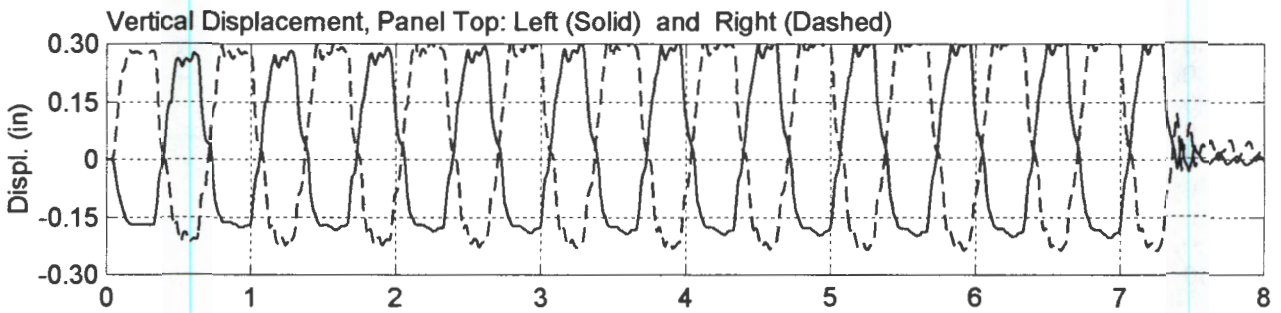
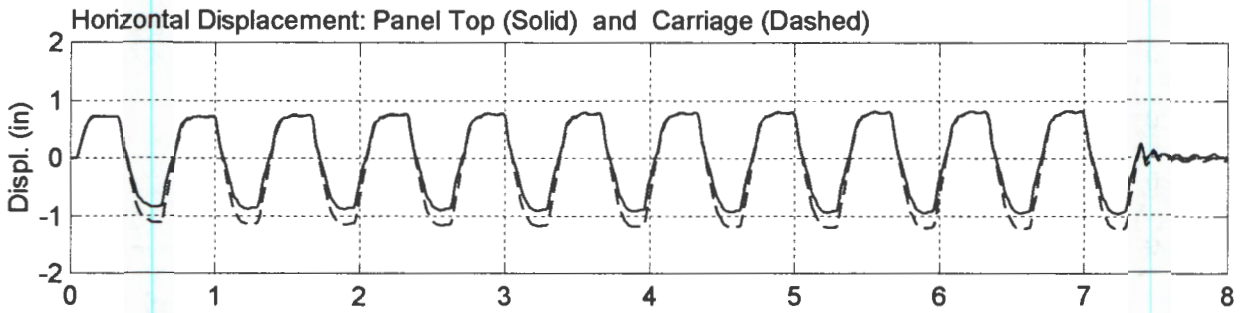
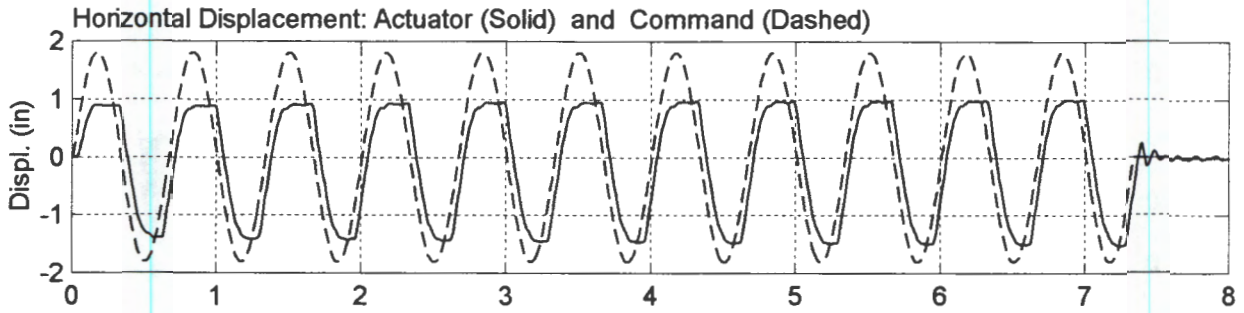

500
C23
97/17
C.2

UCR Rivera Library—Test No. 23 Anchorage B Three Devices (T=200 ft-lbs)
Harmonic Motion (1.5 Hz, 1.8 in) File: 06271553.txt

