

UCLA

UCLA Electronic Theses and Dissertations

Title

Applying Systems Science Methods to Risk-Based Disease Management and Population Oral Health

Permalink

<https://escholarship.org/uc/item/1649b99h>

Author

Flint MacBride, Robin A.

Publication Date

2018

Peer reviewed|Thesis/dissertation

UNIVERSITY OF CALIFORNIA

Los Angeles

Applying Systems Science Methods to Risk-Based
Disease Management and Population Oral Health

A dissertation submitted in partial satisfaction of the
requirements for the degree of
Doctor of Public Health

by

Robin Audrey Flint MacBride

2018

© Copyright by

Robin Audrey Flint MacBride

2018

ABSTRACT OF THE DISSERTATION

Applying Systems Science Methods to Risk-Based
Disease Management and Population Oral Health

by

Robin Audrey Flint MacBride

Doctor of Public Health

University of California, Los Angeles, 2018

Professor Neal Halfon, Chair

Policymakers and public health practitioners face many complex population and health care related problems that cannot be fully understood by simply understanding the component parts. However, the predominant approach in research, practice and policymaking is to approach complex problems with reductionist thinking and methods. Complex systems methods such as agent-based modeling (ABM), System Dynamics (SD) and discrete-event simulations are well suited to deal with the inherent complexity of populations and delivery systems and complement reductionist approaches.

Early childhood caries and the dental care delivery system are good examples of complex systems at many levels. Caries is a complex multifactorial disease that is both infectious and chronic. It is one of the most prevalent chronic conditions in the U.S. and the world, and it is therefore a costly disease, not just financially, but also the impact it can have on learning, development and social engagement of children. Oral health disparities persist in vulnerable

populations despite marked improvements in the overall oral health of the nation in the last 50 years. Developments in risk-based care and disease management in the last decades have demonstrated its ability to reduce disease and its consequences, yet it is generally not used to its full potential in dentistry.

An overarching goal of this dissertation is to demonstrate the utility and feasibility of a system-science approach for analyzing interconnected population and health care problems. I draw on the system science toolkit to, first, take a holistic view of the system influences on dentists' behaviors, and second to use a hybrid simulation model to explore the structure and dynamics of a risk based and disease management approach to dental care and population oral health. The simulation provides a demonstration of ways to harness the strengths of agent-based models, system dynamics models, and discrete event simulations to represent and learn about the structures driving the system's behaviors and the underlying interactions at the individual level of patients and providers.

Overall, the modeling process yielded much learning about the disease and dental care process, as well as about the modeling process, its techniques and the language of systems. The findings support the application of these simulation and system thinking tools to aid in learning, planning and to inform the policy making process.

The dissertation of Robin Audrey Flint MacBride is approved.

Moira Inkelas

Nadereh Pourat

James J. Crall

Nathaniel Osgood

Neal Halfon, Committee Chair

University of California, Los Angeles

2018

Dedication

To my beloved parents, Vivian and Roderick Flint.

Da', for your love of learning and creativity to make useful things out of whatever you find.

Ma, your ingenuity, creativity, and persistence to make things work better, and to transform simple things into something beautiful and useful; your energy inspires me, and your laughter and joy keep me smiling.

You both figured out how to make the best lemonade out of life's lemons. You gave me light to pursue a path less travelled, do something hard but useful, to always be learning something new, and to try and make things better for those who can't do it for themselves.

*Thank you for your encouragement, inspiration, love, and support.
I'm glad you are both here to witness this.*

and

To my dear and departed friend, Debra Tom Salgado.

Such a smart, talented, creative, generous and loving soul. I took for granted you'd be here while I finished this; with your help it would not have taken as long (or be as long!). I wish you were here now so we could catch up on all the time we were planning to spend together when you got better and I finished, but I know you'd be proud of me (and bake me my favorite cookies). I'm grateful for all the love and time you generously gave to me, glad that the gift of your life enriched mine and so many others.

Table of Contents

TABLE OF CONTENTS	VI
LIST OF FIGURES	XI
LIST OF TABLES.....	XIII
LIST OF ABBREVIATIONS & ACRONYMS.....	XIV
GLOSSARY.....	XV
Glossary of Dental Terms.....	xv
Glossary of Systems Science Terms.....	xvi
ACKNOWLEDGEMENTS.....	XIX
VITA	XX
CHAPTER 1: INTRODUCTION	1
Dissertation Goals and Objectives.....	8
<i>Aims & sub-aims.....</i>	<i>10</i>
<i>Landscape of this dissertation</i>	<i>13</i>
CHAPTER 2: LITERATURE REVIEW OF CARIES AND DENTAL CARE	15
Introduction to Dental Terminology	15
Oral Health Epidemiology	18
<i>Disparities in oral health.....</i>	<i>18</i>
<i>Disparities in access to dental care</i>	<i>21</i>
The Cost of Caries	29
<i>Dental expenditures.....</i>	<i>30</i>
<i>Emergency dental care and hospitalizations.....</i>	<i>31</i>
<i>Dental care under general anesthesia</i>	<i>33</i>
<i>Effect on other health conditions.....</i>	<i>34</i>
<i>Effect of disparities on military readiness</i>	<i>35</i>
<i>The human cost of caries.....</i>	<i>36</i>
<i>Effect on child development and learning</i>	<i>37</i>
Caries Etiology.....	39
<i>Disturbance of the microbial homeostasis.....</i>	<i>39</i>
<i>Disturbance of the mineral homeostasis.....</i>	<i>45</i>

<i>Acquisition and transmission</i>	54
<i>Stages and progression of disease</i>	58
<i>Risk & protective factors — oral health and personal health behaviors</i>	58
Dental Care Processes of Care.....	59
Risk and Disease Management	60
<i>Motivational interviewing and behavior change</i>	64
<i>Effectiveness of caries risk and disease management in practice</i>	65
<i>Traditional one-size-fits-all approach to caries</i>	67
<i>The conflicting goals of the present-day dental-care business model</i>	70
<i>Patient and population approaches</i>	72
Dental Care Delivery System	74
<i>Dental workforce</i>	74
<i>Financing of dental care</i>	76
<i>Dentist participation in Medicaid</i>	77
<i>Reimbursement rates</i>	78
<i>Providers' reluctance to treat Medicaid patients</i>	79
<i>Alternate workforce models to fill the gap for underserved populations</i>	80
<i>Few dentists treat young children</i>	81
<i>Age of first dental visit</i>	83
<i>Training of general dentists in infant oral health</i>	84
<i>Rationale and benefit of early establishment of dental home</i>	84
Addressing Oral Health Disparities.....	86
<i>Oral health outcomes and effectiveness of care</i>	87
Oral Health and Provider Productivity	88
Chapter 2 Summary	91

CHAPTER 3. CONCEPTUAL APPROACHES TO ANALYZING ORAL HEALTHCARE SYSTEM 93

Complexity in Population Health and Healthcare Delivery Systems.....	95
Conceptual Frameworks of Oral Health and Dental Care Delivery Systems	98
<i>The complex dynamics of health systems and population health</i>	98
<i>Multi-level influences</i>	100
<i>Dimension of time</i>	105
<i>Reciprocal relationships, interactions, and feedbacks</i>	105
Health Care System, Provider Behaviors, and Dental Care Process.....	109
<i>Health system characteristics</i>	110
<i>Provider related influences</i>	110
<i>Process of care – patient-provider interaction</i>	114
<i>Summary of model limitation of models and proposed additions</i>	122
<i>Reductionist vs. complex adaptive system thinking/systems theory</i>	125
Turning to System Science to Capture Complexity	125
<i>System Thinking</i>	125
System Science & Simulation Methods.....	131

<i>System dynamics models</i>	132
<i>Causal loop diagrams and system mapping</i>	134
<i>Agent-based models</i>	135
<i>Discrete event simulations</i>	137
<i>Hybrid models</i>	137
<i>Other complementary methods</i>	138
<i>Use of simulation modeling to solve health and healthcare problems</i>	139
A Functional and Theoretical Framework of Caries Disease, Dental Care, and Population Health	140
Causal Map — System Context for Oral Health and the Dental Delivery System	144
<i>Why Take A Whole System View?</i>	144
Chapter 3 Summary	146
CHAPTER 4: METHODOLOGY	148
Research Design	148
Causal Loop Diagrams or System Maps of Influences on Dentists’ Practice Behaviors and Caries Disease	148
<i>Developing the causal loop diagrams</i>	150
Hybrid Simulation Modelling	151
Research Procedures (Modeling Process)	152
Purpose and Scope	154
Problem Conceptualization	156
<i>Caries disease progression in individuals and populations</i>	157
<i>The dental care process and its interaction with patients</i>	160
Acquiring Data for Model Inputs and Outputs	161
Developing Simulation Model	163
<i>Object roles, boundaries and level of detail</i>	163
<i>Determining model structure and logic</i>	165
<i>Simulation model formulation</i>	165
<i>Outputs of the model</i>	167
<i>Parameters — agents and entity characteristics</i>	168
<i>Actions & rules</i>	170
<i>Bacteria level — a systems dynamics submodel</i>	173
<i>Lesion development</i>	174
<i>The dental care visit (DES)</i>	177
Discrete Event Simulation Elements	178
<i>Time and schedules</i>	183
<i>Model inputs and initialization</i>	183
<i>A note on randomness</i>	188
<i>Graphical interface of the model</i>	190
Model Verification, Calibration, and Validation	193
<i>Model testing</i>	201
Design of Experiments	202

Simulation Execution and Data Analysis.....	204
CHAPTER 5. RESULTS.....	205
Causal Loop Diagram.....	206
1. <i>Risk and disease management versus restorative care.....</i>	<i>206</i>
2. <i>Training and capacity to provide risk-based care versus restorative.....</i>	<i>208</i>
3. <i>Cost and financing of dental care.....</i>	<i>208</i>
4. <i>Patient experiences and demand for care.....</i>	<i>209</i>
<i>Upstream improvements of healthy lifestyles.....</i>	<i>211</i>
Hybrid Simulation Model — Model Building.....	214
<i>Modeling the progression of caries disease.....</i>	<i>214</i>
<i>Modeling the dental care process at a pediatric dental clinic.....</i>	<i>216</i>
<i>Modeling the interaction between the dentist and the patient.....</i>	<i>218</i>
Simulating the Effect of a Risk and Disease Management Approach to Caries on Population Health.....	219
<i>Distribution of risk in the population.....</i>	<i>219</i>
<i>Distribution of lesions in the population.....</i>	<i>221</i>
Simulating the Effect of a Risk and Disease Management Approach to Caries on Dentists' Productivity.....	223
<i>Clinic visits & patients.....</i>	<i>223</i>
Sensitivity of Risk and Disease Management to Patient Factors.....	225
<i>Scenario 1 — Age of first visit.....</i>	<i>226</i>
<i>Scenario 2 — Risk profile of the population.....</i>	<i>231</i>
<i>Scenario 3 — Missed appointments.....</i>	<i>233</i>
CHAPTER 6. SYNTHESIS AND IMPLICATIONS.....	238
Causal Loop Diagram.....	238
Lessons Learned from the Modeling Process.....	238
The Hybrid Simulation Model (ABM(SD) – DES).....	240
Implications of Findings.....	242
CHAPTER 7: CONCLUSIONS & RESEARCH DIRECTIONS.....	245
Need for Training.....	246
Limitations of the Research.....	247
<i>Limitations in the causal loop diagram.....</i>	<i>247</i>
<i>Limitations in the ABM.....</i>	<i>248</i>
<i>Limitations in the DES.....</i>	<i>248</i>
Directions for Future Research.....	249
APPENDIX 1: COMPLEX SYSTEM METHODS AND EXAMPLES.....	251
APPENDIX 2: STATE CHARTS.....	255

APPENDIX 3: QUESTIONS THAT AIDED AND INFORMED THE MODEL DEVELOPMENT	257
APPENDIX 4: ANYLOGIC MODEL SCREENS.....	258
APPENDIX 5: CALIBRATION OF THE LESION DEVELOPMENT HAZARD	259
APPENDIX 6: CALCULATION OF FUNCTIONAL RISK DISTRIBUTIONS SIMULATION MODEL.....	261
REFERENCES	262

List of Figures

Figure 1. Proportion of the US population with caries experience (percentages for 2–5 and 6–8-year-olds reflect the percentages of individuals with caries experience in primary teeth; for ages 9 and above, percentages reflect the percentages with caries experience in permanent teeth) by age (years). From National Health and Nutrition Examination Survey, 2011–2012. National Center for Health Statistics, CDC as cited by Crall & Forest (James J. Crall & Forrest, 2018).....	19
Figure 2. Trajectory plot of mean DMFS scores for three-group caries trajectory analysis model. From (Broadbent et al., 2008).....	29
Figure 3. Population-Based Approach for Dental/Oral Health Delivery (Adapted from Crall, 2005a).....	73
Figure 4. Andersen’s Phase 5 Behavioral Model of Health Service Use including contextual and individual characteristics (Andersen, 2008).....	100
Figure 5. Fisher-Owens conceptual framework of the influences on child oral health.	103
Figure 6. Lee & Divaris’ proposed framework to conceptualize and act up on eliminating sources of oral-health disparities. (Lee & Divaris, 2014)	109
Figure 7. Adaptation and expansion of behavioral model of health service used to emphasize the influence of health system and provider factors on provider behaviors and process of care, and resulting outcomes for both providers and patient populations. Red Dots signify additions or modifications.....	124
Figure 8. Agent oral health dynamics and lesion development.....	141
Figure 9. Feedbacks between population oral health, dental care process and approach, and provider and patient outcomes.	141
Figure 10. Modeling and simulation process (adapted from Benjamin, Patki, & Mayer, 2006 and Loper, 2015).....	152
Figure 11. Relationship between population oral health and dental clinic operations.....	156
Figure 12. Micro-level relationship between individual risk and disease and dental clinic protocol and care pathways.	157
Figure 13. Stages of caries development.	158
Figure 14. Influences of different aspects of dental care on caries disease process development.....	159
Figure 15. Clinic Workflow and Decision Logic	162
Figure 16. Model Outputs from different parts of the model	168
Figure 17. System Dynamics submodel of bacterial CFU/ml.....	173
Figure 18. Lesion Status State Chart	175
Figure 19. Discrete event simulation of the “traditional” and “risk-based” care process at a dental clinic	180
Figure 20. AnyLogic main view during simulation.....	191
Figure 21. AnyLogic View of person screen and associated statecharts when model is running	191
Figure 22. AnyLogic View of simulation model clinics view during simulation	192

Figure 23. AnyLogic Simulation experiment screen	193
Figure 24. Illustration of verification, calibration, and validation.....	194
Figure 25. Parameters determining bacteria level that were calibrated	197
Figure 26. Parameters informing the lesion development transition rates that were calibrated	197
Figure 27. Risk and disease management versus restorative loops	208
Figure 28. Causal System Map of the influences on disease and dentists' practices	213
Figure 29. Distribution of risk states across a population of children (0–12). These results are from iteration 2, but all look quite similar.	219
Figure 30. Distribution of lesion states across a population of children (0–12 years) attending a risk-based or traditional clinic.....	219
Figure 31. Annual visits at a risk-based and traditional clinic; total and by type (0–12-year-olds). These results are from iteration 2, but all look quite similar.	222
Figure 32. Total visits per year and unique patients per year for a risk-based clinic vs traditional	223
Figure 33. Average number of visits per patient per year — Risk-Based vs Traditional	224
Figure 34. A 2D histogram of age of first dental visit by cavity years.....	227
Figure 35. A 3D Histogram of percent population by age of first dental visit and time with cavities (cavity years).....	228
Figure 36. Age of first dental visit by cavity years, by clinic type; average of 5 runs	229
Figure 37. Results of sensitivity analysis 1; age of first dental visit. Effect on risk and lesion distributions by type of clinic. (Results from run #2).....	230
Figure 38. Results sensitivity analysis 2; Population risk profile on the volume and type of visits by type of clinic)	232
Figure 39. Agent probability of missed appointments (25%) on risk and lesion status.....	234
Figure 40. Agent probability of missed appointments (75%) on risk and lesion status.....	234
Figure 41. Agent probability of missed appointments (25%) on total Visits and types of visits (years 2015-2055)	235
Figure 42. Agent probability of missed appointments (50%) on total visits and types of visits (years 2015-2055)	235
Figure 43. Agent probability of missed appointments (75%) on total visits and types of visits (years 2015-2055)	235

List of Tables

Table 1. Six-Step Protocol for Infant Well Baby Oral Care Exam (IOCE)	62
Table 2. Characteristics and Language of Complex Adaptive Systems	96
Table 3. List of model assumptions	164
Table 4. Simulation methods used to model caries disease and dental care	166
Table 5. Summary of Statecharts, states and transition rules	172
Table 6. Factors associated with risk levels	176
Table 7. Services provided by visit and clinic type, with procedure times and visit intervals	182
Table 8. Initial parameter settings for baseline simulation	183
Table 9. Input values for initial distributions, parameters related to disease progression	184
Table 10. Sugar exposure and toothbrushing frequency multipliers	198
Table 11. Excel table used for calibration of lesion development hazard coefficients	199
Table 12. Description of Scenarios Examined	203
Table 13. Population health descriptive statistics from baseline simulation (in years)	215
Table 14. Sample calculation of implications of differences in visit counts (at year 10)	225
Table 15. Description of Scenarios Examined	226

LIST OF ABBREVIATIONS & ACRONYMS

AAP	American Academy of Pediatrics	EPSDT	Early and Periodic Screening, Diagnostic, and Treatment
AAPD	American Academy of Pediatric Dentistry	HA	hydroxyapatite
ABM	agent-based model	ICDAS	International Caries Detection and Assessment System
ADA	American Dental Association	IOCE	Infant Well Baby Oral Care Exam
ADHP	American Dental Hygiene Practitioner	IOM	Institute of Medicine (now National Academy of Medicine)
CAMBRA	Caries Management by Risk Assessment	JDPBRN	Japanese Dental Practice-based Research Network
CAS	complex adaptive systems	MEPS	Medical Expenditure Panel Survey
CDA	California Dental Association	MI	Motivational interviewing
CDC	Center for Disease Control & Prevention	MS	mutans streptococci
CDHC	Community Dental Health Coordinator	NaF	sodium fluoride
CDT	current dental terminology	NHANES	National Health and Nutrition Examination Survey
CFUs	colony forming units	NIDCR	National Institute of Dental and Craniofacial Research
D&I	Dissemination and implementation	NIH	National Institutes of Health
DES	discrete event simulation	OBSSR	Office of Behavioral and Social Sciences Research
DFS/dfs	decayed and filled surfaces; ALL CAPS = permanent teeth, lowercase = primary teeth	PPACA	Patient Protection and Affordable Care Act
DHAT	Dental Health Aide Therapist	ppm	parts per million
DMFS/dmfs	decayed, missing and filled surfaces; ALL CAPS = permanent teeth, lowercase = primary teeth	RB	risk-based
DPBRBN	Dental Practice-Based Research Networks	RVUs	relatively value units
DT	Dental Therapist	SD	system dynamics
E	energy (total caloric intake)	SDF	silver diamine fluoride
ECC	Early childhood caries	SDM	shared decision making
ED	emergency department	SES	socioeconomic status
EFDA	Expanded Function Dental Assistant	WIC	Women Infants and Children
EFDH	Expanded Function Dental Hygienist	WSL	white spot lesion

GLOSSARY

Glossary of Dental Terms

<i>Acidogenic</i>	Having a quality of producing acid.
<i>Aciduric</i>	Having a quality of acid resistance.
<i>Biofilm</i>	A thin, slimy film of bacteria that adheres to a surface.
<i>Cavitated vs non-Cavitated lesion</i>	A cavitated lesion has broken through the enamel and created a hole in the tooth; a non-cavitated lesion is where bacteria have begun the process, but the surface of the tooth remains intact.
<i>Deciduous teeth</i>	Primary (baby) teeth.
<i>Demineralize</i>	The drain of minerals (calcium and phosphate) from a tooth; if this continues unchecked, white spot lesions will form and eventually the tooth will succumb to caries.
<i>Dentine caries</i>	Enamel that has broken down and exposed dentin; what occurs when a White Spot Lesion that has progressed through the enamel and into the dentin, commonly referred to as a cavity.
<i>Enamel caries</i>	see White Spot Lesion
<i>Fissures</i>	Pits and fissures are the deep grooves that make up the chewing surfaces of teeth. These grooves are found on both premolars and molars.
<i>Inactive vs active lesions</i>	Lesions are active when nothing is being done about them; without interference, they will progress to form a cavity. An inactive (or arrested) lesion has received treatment and the progression has been stopped\
<i>Incipient lesions</i>	A lesion at an early stage.
<i>Occlusal</i>	Denoting a portion of a tooth that comes into contact with a tooth in the other jaw.
<i>Pellicle</i>	A protein film that forms on the surface enamel by selective binding of glycoproteins from saliva that prevents continuous deposition of salivary calcium phosphate. It forms in seconds after a tooth is cleaned or after chewing. It protects the tooth from the acids produced by oral microorganisms after consuming carbohydrates.
<i>Pit</i>	see Fissures
<i>Plaque</i>	Dental plaque is a biofilm or mass of bacteria that grows on surfaces within the mouth. It is a sticky colorless deposit at first, but when it forms tartar, it is often brown or pale yellow. Also known as microbial plaque, oral biofilm, dental biofilm, dental plaque biofilm or bacterial plaque biofilm. Bacterial plaque is one of the major causes for dental decay and gum disease.
<i>Primary teeth</i>	A child's first set of teeth; baby teeth. Also referred to as deciduous as they fall out.
<i>Primary vs. Secondary (or recurrent) caries</i>	Primary caries is used to differentiate lesions on natural, intact tooth surfaces from those that develop adjacent to a filling, commonly referred to as recurrent or secondary caries.

<i>Proximal/interproximal</i>	Proximal is an umbrella term that refers to the surfaces of a tooth that normally lies adjacent to another tooth. Interproximal refers to the space between teeth.
<i>Secondary/permanent teeth</i>	Adult teeth that replace primary teeth.
<i>Streptococci mutans and mutans streptococci</i>	
<i>White Spot Lesion</i>	The presence of clinically detectable, localized areas of enamel demineralization, observed as chalky white spot lesions of different opacity, is a sign that the caries process has begun. It is found on the smooth surfaces of teeth and has a milky appearance.

Glossary of Systems Science Terms

<i>Adaptive Behavior</i>	An agent adjusting their behavior to its current (new) state, to the states of other agents, and to their environment.
<i>Autonomy</i>	Freedom from external control or influence; independence; the capacity of an agent to act independently from others.
<i>Balancing Loop</i>	A balancing loop attempts to move some current state (the way things are) to a desired state (goal or objective) through some action (whatever is done to reach the goal). The balancing loop is one of the two foundational structures of systems thinking, the other being the Reinforcing Loop. A balancing loop is representative of any situation where there is a goal or objective, and action is taken to achieve that goal or objective.
<i>Causal Loop Diagram</i>	A closed loop of cause-and-effect linkages which captures how variables in a system are interrelated.
<i>Complex Adaptive Systems</i>	A complex adaptive system is a system in which a perfect understanding of the individual parts does not automatically convey a perfect understanding of the whole system's behavior. The study of complex adaptive systems, a subset of nonlinear dynamical systems, is highly interdisciplinary and blends insights from the natural and social sciences to develop system-level models and insights that allow for heterogeneous agents, phase transition, and emergent behavior.
<i>Computer Modeling</i>	Constructing and manipulating abstract (mathematical and/or graphical) representations of economic, engineering, manufacturing, social, and other types of situations and natural phenomenon, simulated with the help of a computer system.
<i>Computer Simulation</i>	see Computer Modeling
<i>Dynamic Properties</i>	Characterized by constant change, activity, or progress. Changing over time.
<i>Emergence</i>	System dynamics that arise from how the individual components interact and respond to each other and their environment. How a system's behavior arises from and is linked to the characteristics and behaviors of its individual components.
<i>Endogenous Variables</i>	factors determined from within the model where values can depend on each other and on exogenous variables.
<i>Exogenous Variables</i>	Variables whose values are determined outside the system, affecting endogenous variables without being affected by them.
<i>Feedback</i>	An essential concept in a systems view; the return of information about the status of a process.

<i>Feedback Loop</i>	A feedback loop refers to a situation where part of the output of a situation is used for new input, an “effect” returning to its “cause,” which can cycle infinitely. Feedbacks are what run complex systems. They can be reinforcing (positive or negative) or balancing.
<i>Flow</i>	The amount of change something undergoes during a particular unit of time. For example, the amount of water that flows out of a tub each minute, or the amount of interest earned in a savings account each month. Also called a rate.
<i>Homeostasis</i>	The tendency toward a relatively stable equilibrium between interdependent elements, especially as maintained by physiological processes.
<i>Interaction</i>	A particular way in which parts of a system act or respond to each other; mutual actions affecting the behavior or nature of the objects, bodies, phenomena, or influence.
<i>Iterative Learning</i>	Learning through the act of repeating a process to generate a (possibly unbounded) sequence of outcomes, with the aim of approaching a desired goal, target, or result. Each repetition of the process is also called an “iteration,” and the results of one iteration are used as the starting point for the next iteration.
<i>Leverage Point</i>	An area where small change can yield large improvements in a system.
<i>Mechanism</i>	A natural or established process by which something takes place or is brought about.
<i>Negative Feedback Loop</i>	see Balancing Loop
<i>Positive Feedback Loop</i>	see Reinforcing Loop
<i>Rate</i>	see Flow
<i>Reductionism</i>	The practice of analyzing and describing a complex phenomenon in terms of phenomena that are held to represent a simpler or more fundamental level and particularly about the pieces of the system, especially when this is said to provide a sufficient explanation.
<i>Reinforcing Loop/Process</i>	Along with balancing loops, it forms the two building blocks of dynamic systems. Reinforcing processes produce both growth and collapse — they compound change in one direction with even more change. A reinforcing loop depicts a reinforcing process. Also known as Vicious Cycles or Virtuous Cycles and Positive Feedback Loops.
<i>Simulation Model</i>	One of the ten tools of systems thinking. A computer model that allows you to map the relationships that are important to a problem or an issue and then simulate the interaction of those variables over time.
<i>Structural Diagram</i>	Draws out the accumulators and flows in a system, giving an overview of the major structural elements that produce the system’s behavior. Also called Forrester Diagrams, Stock and Flow Diagrams, or Accumulator/Flow Diagrams.
<i>Structure</i>	The manner in which the elements of a system are organized or interrelated; the building blocks of a larger system. It includes not only the organizational chart, but incentive systems, material flows, accumulations, information flows, and interpersonal interactions. The terms structure and system are sometimes used interchangeably.
<i>System Dynamics</i>	A field of study which includes a methodology for constructing computer simulation models to achieve better understanding and control of feedback-rich social and corporate systems. It draws on organizational studies, behavioral decision theory, and engineering to provide a theoretical and empirical base for structuring the relationships in complex systems.
<i>Systems Archetypes</i>	One of the ten tools of systems thinking. Systems archetypes are the “classic storylines” in systems thinking—common patterns and structures that occur repeatedly in different settings.

<i>Systems Science</i>	An interdisciplinary field of science that studies the nature of complex systems in nature, society, and science, aiming at developing interdisciplinary foundations that are applicable in a variety of areas including engineering, biology, medicine and social sciences.
<i>Systems Thinking</i>	A school of thought which focuses on recognizing the interconnections between the parts of a system and synthesizing them into a unified view of the whole.

The above glossary is a compilation of definitions from many sources, including:

- Innovation Associates' *Systems Thinking: A Business Perspective*
- Gould-Kreutzer Associates' *Introduction to Systems Thinking*
- *The Fifth Discipline* by Peter Senge
- *High Performance Systems' Academic User's Guide to STELLA*
- The American Heritage and Random House Dictionaries
- wikipedia.org

Acknowledgements

In pursuing my doctorate and this project in particular, my goal was to do something I had passion for, learn something new, and come up with something useful. Well, I managed to pursue something I had a passion for, learned a lot, and I hope at some point it will be useful. It took a long time, so there are many amazing minds, teachers, and kind hearts to thank for helping me get to the end of this project.

To my Committee members, thank you for your patience and for hanging in there with me through this turbulent ride through mostly uncharted waters:

Dr. Nathaniel Osgood, thank you for your constant encouragement, your amazing mind paired with a humble love of learning, and teaching the rest of us how to learn, think, and understand things to make this a better world for everyone. This project would not have been possible without your support and mentoring. I almost gave up on using system science the day before I met you!

To Dr. Neal Halfon, my chair and advisor, for teaching me that systems can be made better. Thank you for believing in me, and helping shepherd this project to the finish line.

To Dr. Moira Inkelas, for helping me understand how systems can be improved through quality improvement.

To Dr. Jim Crall, for all you have taught me this last decade about possibility thinking around population oral health.

To Dr. Nady Pourat, for your keen mind and research skills, encouragement, and willingness to journey with me in this.

To the computer science students at the University of Saskatchewan who provided invaluable technical support for my simulation model:

Drs. Winchell Qian and Kurt Kreuger, where it all started at ABM Bootcamp, love the way you guys think, and thanks for shedding light on the path forward.

Alex Dumais, an amazingly talented, generous, and humble young man; I will always recall with a smile discovering the joys (and frustrations) of late night, across the world, co-modeling! I have a debt of gratitude to you for taking this on and helping me to the finish line.

To my many good friends — particularly Maria Felipe, Maria and Max Couce, Stephanie Faloon, Daphne Hemsley, Barbara Crandall, Maggie Steuwer, Kellie Thompson, Becky Colarik, Kathy Howarth, and so many more — who've traveled this road with me praying that I'd finish so you could have me back! Your encouragement was invaluable, and your prayers have finally been answered. Thank you for being there even when I couldn't be.

To my friends and colleagues at the Center for Healthier Children, Families, and Communities — thank you for your friendship and inspiration for what we do all these years, Lisa Stanley, Lou Brown, Leila Espinosa, Lori Crawford, Lynette Lau, Efren, Emily — you guys are all amazing. To my DrPH cohort who left me behind — you are all amazing women! Thanks Judith for the support to break through.

To Dr. Linda Bourque for your encouragement to pursue doctoral studies — thanks for believing I could do it and giving me the foundation to be able to. To Dr. Francisco Ramos Gomez, for your encouragement and contagious passion for making things better for children. Thank you to my UCLA professors who taught me about complexity and simulation, Dr. John Bragin, Bill McKelvey, and Dario Nardi.

To Rebecca Staton for holding my hand through this long journey, helping me stay sane and believe in myself.

To my family — what a long road, thanks for believing in and encouraging me! I'm sorry wasn't more available when the kids were growing up. Hope to see more of you now!

Last but far from least, a very special thanks to my dearest husband and partner, Andy. You make it all worthwhile. Without your encouragement, love, and help, this may not have been possible.

VITA

EDUCATION

- MPH, Population and Family Health; UCLA Department of Community Health Sciences, 1993
- BS, Community Nutrition; Cornell University, 1989

EXPERIENCE

- UCLA Center for Healthier Children, Families & Communities, School of Public Health November 1996–Present. Projects funded through UCLA Pediatric Dentistry; employed by SPH Department of Health Policy & Management:
 - Project Manager — QI Learning Collaborative & Evaluator for UCLA First 5 LA Oral Health Program, UCLA School of Dentistry; July 2012–Present
 - Lecturer — Pediatric Dentistry; July 2009–Present
 - Program Manager — Community Health & Advocacy Training in Pediatric Dentistry; July 2006–2012
 - Program Manager — MCHB Leadership Training Program in Pediatric Dentistry; July 2007–2012
 - Coordinator — Children’s Oral Health Collaborative of Los Angeles County; September 2007–2009
 - Coordinator — National Oral Health Policy Center / Project Manager, School of Dentistry; August 2004–2009
- Mission Support, STS-99 Shuttle Radar Topography Mission — JPL/NASA, Pasadena CA & Johnson Space Center, Houston, TX; June 1999–February 2000
- Project Manager (96-98), Director (98-2000), Immunization Registry Development Project — Child Health and Immunization Network (CHAIN), Los Angeles; November 1996–July 2000
- Immunization Projects Manager — Cedars-Sinai Medical Center, Department of Pediatrics, Los Angeles; September 1995–November 1996
- Project Manager, Pediatric Asthma Study — R.W. Johnson Clinical Scholars Program & Dept. Of Pediatrics, UCLA School of Medicine; April 1995–September 1995
- Administrative Assistant/Librarian — Jet Propulsion Laboratory, Spaceborne Imaging Radar, C Project Office, Pasadena, CA; March 1994–April 1995
- Comprehensive Perinatal Health Worker December — Early Parenting Center, Huntington Beach, CA; 1993–January 1994
- Nutrition Counselor — The Public Health Foundation Women, Infants and Children, Los Angeles 1989 – 1991

SELECT PUBLICATIONS

- Kreuger, Kurt, Robin Flint MacBride, and Nathaniel Osgood. “Beyond Drill and Fill: Modeling the Impacts of Risk-based Care on Oral Health Disparities.” *Growing Inequality: Bridging Complex Systems, Health Disparities, and Population Health*. (G.A. Kaplan, A. Diez Roux, S. Galea, and C.P. Simon, eds), Washington, DC: Westphalia Press, 2017.
- Flint MacBride, R. “If we can, why not prevent caries? A complex systems approach to study the impact of changes in dental practice and its effect on population health.” Poster presented at the Southern California Dissemination, Implementation & Improvement Science Symposium, Los Angeles, CA, May 2017.
- Flint MacBride, R, Inkelas, M., Lampron, C., Scoville, R., Crall, J. “Integrating Risk-Based Oral Health Care in Medical and Dental Care Settings - Evaluation of an Innovation QI Learning Collaborative.” Presentation at American Public Health Association Annual Meeting, Denver, CO, Oct 2016.

Chapter 1: Introduction

Caries is one of the most prevalent diseases in the U.S. and worldwide, resulting in significant morbidity and in some cases death. It is a multifactorial, transmissible, chronic and progressive bacterial infection that results in dental lesions that usually progress to become cavities with the potential for tooth loss later in life. “Early childhood caries” (ECC) refers to cavities in the primary teeth of young children; technically, when a child six years old or younger has one or more teeth that is decayed, missing (resulting from caries), or filled (American Academy of Pediatric Dentistry, 2008; Drury et al., 1999a). Early childhood caries is the most common disease of childhood and one of the costliest diseases in the world. It is five times more common than asthma, four times more common than early-childhood obesity, and 20 times more common than diabetes (US Department of Health and Human Services (DHHS), 2000). About one of every four children in the U.S. experiences decay before they reach kindergarten, rising to over half of 6–8-year-olds. It is highly concentrated among children from low socioeconomic status (SES) backgrounds, racial/ethnic minorities, and immigrants (Dye, Thornton-Evans, Li, & Iafolla, 2015a).

Caries-causing bacteria is generally transmitted vertically from mother (or caregiver) to child at a young age. While our mouth carries over 500 types of bacteria, to date there are only a handful implicated in caries. Caries is commonly acquired through transmission of *mutans*

*streptococci*¹ from mothers (or active caregiver) to their infants (Dye, Vargas, Lee, Magder, & Tinanoff, 2011; Y. Li & Caufield, 1995). Preventive and restorative treatment of the mother can prevent or delay a child's acquisition of the harmful, caries-causing bacteria. In addition to the biological transmission of caries, there is also an important "social contagion" aspect to the progression of the disease (Fisher-Owens, 2014). Lifestyle risk factors related to dental hygiene, dental anxiety, and eating habits are learned early in life and inherited by exposure to older members of the family.

An individual's exposure to sugar, fluoride, oral hygiene habits and preventive care will interact in complex ways to determine whether the plaque-forming bacteria will accumulate and result in caries disease, diagnosed by the presence of dental lesions and cavities. Children who are exposed to the cariogenic bacteria and infected at a younger age tend to develop much more aggressive caries (Fisher-Owens, 2014) and at an earlier age. Early childhood caries is the greatest risk factor for caries in permanent teeth (Fisher-Owens, 2014; Li & Wang, 2002; Wen et al., 2012). This progressive nature of the disease is manifested in the escalating prevalence rates across life stages, with a majority of 6–8-year-old children showing decay, two-thirds by adolescence (Dye et al., 2015a), and considerably higher rates yet among adults (Dye, Thornton-Evans, Li, & Iafolla, 2015b).

A progressive disease that is not self-limiting, caries results (along with periodontal disease) in a complete loss of natural teeth in about 20% of adults 65 years or older. These rates are consistently lower for white and non-poor Americans, and consistently higher for lower-income people and minorities.

1. *Mutans streptococci* is an informal name given to the group of streptococcal species that are the main contributors to caries, which includes *Streptococcus mutans* and *Streptococcus sobrinus*.

Access to dental care, like the burden of disease, is also unequally distributed in the population. Therefore, rates of untreated decay exhibit similar disparities as disease (Dye, Li, Beltrán-Aguilar, & others, 2012; Dye et al., 2015a, 2015b). Given the price elasticity of dental care and market problems with dental care services, the distribution of access to preventive care is and exhibits marked gradients along socioeconomic, educational and ethnic/race gradients in the population. Medicaid is the government's way to attempt to address the inability of parts of the population to enter the market for dental care in spite of real or perceived needs. However, in most cases, state Medicaid programs have been ineffective purchasers of dental services, failing to secure adequate networks of dentists. The result is that less than 50% of children receive dental services (“CMS-416,” 2017) to which they are entitled because they are unable to find a dentist who will accept their Medicaid coverage.

The traditional method of treating dental caries continues to focus on tooth restoration, much as it was a century ago (Hurlbutt & Young, 2014). However, there is ample evidence to suggest that intervening in the causal factors of the disease can prevent and control manifestations of the disease that many generations accepted as a fact of life. Intervening early in life with primary and secondary prevention strategies can help lower the burden and cost of disease over the life course. Caries management by risk assessment has emerged as a new paradigm in dental care; it is an evidence-based model recommended as a best practice to treat and prevent the causal drivers of the disease at the patient level. A risk-based approach to dental care differs significantly from the traditional surgically oriented approach in that its focus is at the patient level rather than at the tooth level, and it aims to minimize risk factors contributing to the progression or initiation of the disease. Worldwide, most dentists, other than in Scandinavian countries, continue to rely on the traditional surgical-restorative approach of “drill and fill” once

a cavity has been identified. Since restorations do not last forever, and new lesions tend to form next to where original cavities were, this approach leads to a cycle where more, larger and more invasive restorations are required without affecting the course of the disease or preventing future decay (Featherstone et al., 2012; Ismail et al., 2013).

This risk-based approach is a critical component of a movement across the globe towards “minimally invasive dentistry” that seeks to reorient the practice of dentistry towards the conservation of tooth structure as priority (Ericson, Kidd, McComb, Mjor, & Noack, 2003; Murdoch-Kinch & McLean, 2003). Tools, protocols, and effectiveness studies exist for the assessment and management of risk factors before they express as disease or in the early stages of disease ((AAPD), 2015a; Abanto et al., 2015; Banas, 2013; Center for Scientific Information, 2017; Cheng, Chaffee, Cheng, Gansky, & Featherstone, 2015; Featherstone, 2000, 2006; Featherstone & Chaffee, 2018; Jokela & Pienihäkkinen, 2003; Kakudate et al., 2015; Mitchell et al., 2017; Ng et al., 2012; Pienihäkkinen & Jokela, 2002; Pienihäkkinen, Jokela, & Alanen, 2005; Ramos-Gomez, Crystal, Ng, Crall, & Featherstone, 2010; Rechmann, Jue, Santo, Rechmann, & Featherstone, 2018; Warren et al., 2010). However, uptake among dentists has been slow, likely due to the pace at which reimbursement and training programs recognize and embrace the value of this approach to care. It can be argued that this slow adoption of evidence to inform the manner in which caries is managed represents a public health failure on the part of oral health providers (Hurlbutt & Young, 2014).

Like so much of healthcare, this is a complex adaptive problem. Public health and healthcare delivery systems suffer no lack of substantial, complex problems. Often attempts to intervene in complex problems result in unintended consequences, because the solutions do not account for system issues that cannot be reduced to a single factor or root cause. The 1999 Institute of

Medicine's report *To Err is Human* reported on the level of medical errors resulting from procedures intended to protect or improve health. This is an example of these unintended consequences. From a system-science perspective, the reason why health care interventions often fall short of objectives and have unintended consequences is that the focus is often on what is visible, or on specific elements or players, while failing to acknowledge the larger system within which healthcare delivery occurs. It is important to recognize the importance of relationships, interactions between the parts and the effects of the multidimensional nature of complex systems.

The issues of oral health lies at the intersection of several levels of complexity: The biome within the mouth and the individual; the dental care delivery system with its financing, training programs, professional organization, culture and regulations; and population health where individuals interact to produce aggregate behaviors and disease patterns distinct from the individuals which often feed back upon individuals to shape the well-being of populations. These are all examples of complex adaptive systems (CAS).

Complex adaptive systems are systems made up of populations of adaptive agents, where there are no leaders that coordinate the actions of others. Agents act and interact following what are often simple rules (but do not have to be), and patterns and structures that characterize the system and emerge as a result of agent interactions and self-organization. These systems are further characterized by behaviors and relationships that exhibit feedbacks, resulting in nonlinearities or tipping points. CAS provides a framework to understand system properties and processes and resulting phenomena.

Bringing behavior and cognitive theories to bear on the matter of introducing a new practice in dental practices such as the risk-based approach to caries disease management points to the need to consider multiple levels of influence on the provider and how the provider's behavior

can impact the patient-provider interaction as well as have feedbacks to the health system context. We must consider the guidelines and the practice-based evidence that undergird them. It also is helpful to take a broader system view of the resistance to change or failure to adopt new approaches, and how a supportive context and structure for change can be created. The role of habit in the formation of the behaviors of professionals points to the importance of incorporating evidence-based practices in dental school and advanced training programs. This is the place where habits are initiated and then reinforced in clinical practice.

Population health problems as well as health care delivery problems are complex, often difficult to study, and persist despite repeated attempts to address them (El-Sayed & Galea, 2017). These problems are interconnected with other problems that are also resistant to change and intervention. Their causation is often in other social problems, equally pernicious and challenging to study and solve. They are problems that, no matter how many attempts are made, remain difficult to study and resistant to intervention and positive change. We call them “wicked” problems (Blackman, Hunter, Mckee, & Williams, 2006; Dufour & Steane, 2013; Gawande, 2012; McPhee-Knowles, 2014).

The complexity and characteristics of these problems point to a need for dynamic and complex methods to address the research challenges. Slow adoption of risk and disease management in dentistry makes it difficult to study its impact within a real-world laboratory. In addition to the inherent time delay in being able to appreciate significant observable effects, the value of the intervention at the population level might be difficult to assess given the disconnected nature of the dental care services. Dynamic simulation modeling is an approach to studying complex problems with iterative learning — in which knowledge is increased through repeated cycles of running the simulation deriving insights, refining the model and then running

it again and making additional interventions — that allows us to better understand the structure and behavior of systems and envision future realities, disentangled from the local context, and consider the effects of an intervention. With “what if” questions, we can consider the effects of changing contextual or intervening factors on interventions, and thus expand our mental model of the system’s dynamics. Rather than just focusing on the effect of an intervention on a small part of the system, modeling helps to characterize a broader subset of the system and the effects across micro and macro levels, such as individual patients and dentists as well as at the aggregate patient panel and population.

Caries disease and the persistent socioeconomic and racial/ethnic disparities in access to dental care is an almost perfect example of this kind of complex public health and health services problem — a truly wicked problem. From a system perspective, there are challenges achieving behavior change in individuals, the delivery system has challenges implementing evidence-based practices, and the organization and financing of public programs are described as “broken,” and do not support good oral health for all. The delivery of dental care evolved in a way that responded to the need at the time, but it is not as well suited for the current dental epidemiology. Dentistry is isolated from the rest of health care delivery — training of dentists is separate from that of physicians, the financing and insurance for dental health is completely separate from medical — yet we know that it is an integral part of overall health and well-being. This might also explain why oral health conditions have historically received minimal attention in public health training curricula.

The complex etiology of caries involves multiple layers of cause and effect. It involves interactions and feedbacks between the individual and the population-level health and health service sector; it entails complex interactions in the mouth nested within and influenced by

behaviors of the individual, who in turn is affected by the sociocultural, political, and health system environment. Studying the feedbacks and interactions within one level is challenging, let alone across the multiple levels of influence. It is particularly daunting without “learning tools” (better, “learning prostheses”) offered by simulation modeling. Given this complexity, we need what help we can get — the alternative is not good.

Dissertation Goals and Objectives

Both governmental and nongovernmental health agencies, including the National Institutes of Health (NIH), Centers for Disease Control and Prevention (CDC), the Institute of Medicine (IOM), and many others, have acknowledged the value of systems science (Gerberding, 2005; Hussey et al., 2013; Leischow et al., 2008; Leischow & Milstein, 2006; Mabry, Olster, Morgan, & Abrams, 2008; Milstein, 2006). Accordingly, investments in understanding the potential of systems science and its applications to public health problems have been growing through a widening array of funded research and training programs (Mabry & Kaplan, 2013).

Similarly, national organizations and health agencies have formally acknowledged the value of systems science and systems thinking for approaching the design of a 21st-century healthcare system and addressing some of our most persistent health disparities (Mabry, Milstein, Abraido-Lanza, Livingood, & Allegrante, 2013). An entire appendix of the Institute of Medicine’s 2001 *Crossing the Quality Chasm* report was dedicated to the concepts of complex adaptive systems and new ways to approach how we study and design them (Plsek, 2001). The Office of Behavioral and Social Sciences Research (OBSSR) at the National Institutes of Health (NIH) has promoted system-science approaches as a way to promote interdisciplinary and multilevel approaches that fulfill the mission of NIH to utilize science in pursuit of knowledge about the

nature and behavior of living systems and the application of that knowledge to extend life and reduce burdens of illness and disability (Mabry et al., 2008). There have been numerous calls for proposals for applications of system science to addressing diverse health issues and disparities.

An overarching goal of this dissertation is to demonstrate the utility and feasibility of a system-science approach for analyzing population and health care problems. I respond to the call by IOM, NIH, OBSSR, and others to use system-science methods, underutilized in public health, to study an approach to caring for a high-burden disease which generally also receives disproportionately little attention in public health. In this dissertation I draw on the recommended toolbox of system science methods to study this problem. What we cannot seem to do in the real world we can sometimes simulate in a virtual one. To face this seemingly insurmountable set of challenges, software for dynamic modeling lets us simulate complex problems and, through a process of iterative learning, expand our understanding of the system structure and behavior.

First, I apply systems thinking methods to develop a causal loop diagram or system map of the broader network of influences on provider practices and disease progression. By making explicit my assumptions about the influences in the system, I can begin a conversation with other stakeholders, integrate different perspectives on the problem, fill knowledge gaps and identify where data is lacking and where more research may be warranted.

Second, I pilot complex system methods for dynamic simulation modeling to demonstrate the use of simulation methods to study challenging and complex problems of consequence to population health. This approach will allow me to explore dynamics at and across the individual, population, and care delivery levels, and demonstrate the type of outputs that can be generated.

This study introduces the use of a hybrid simulation using an agent-based (ABM) and system dynamics (SD) model to simulate disease progression in a population connected to a

discrete event simulation (DES) that models a typical and stylized dental care delivery process and its interaction with the patients. This approach allows me to analyze factors from various levels of influence on childhood dental caries. Furthermore, using “what if” questions and scenarios, we can envision future realities disentangled from local context and constraints of time. We can consider the effects of an intervention, its implementation, and concomitant contextual factors.

Aims & sub-aims

In this dissertation I employ these system science tools:

Aim 1: Apply a systems thinking approach to conceptualize system influences on dentists’ adoption of a risk and disease management approach to dental care. Sub-Aims include:

- To examine the broader oral health system by developing a set of causal loop diagrams describing influences on provider practices and disease progression, and identify possible high leverage points.

Aim 2: Develop a simulation model as a demonstration of its utility and feasibility to gain insights into population and health care problems. Specifically, to use a model to compare the use of a caries risk and disease management approach to dental care compared to a traditional one-size-fits-all approach, and its effects on oral health outcomes and dentist productivity over time. Sub-Aims include:

- Conceptualize and build a simulation model of caries disease in children and a typical or stylized dental care process.
- Run the model and generate some preliminary results as an example of the types of outputs simulation models can produce.
- Report on the modeling process and lessons learned.

Aim 3: Use “what if” scenarios to test the sensitivity of the intervention to variation in patient-related factors including age of initiating care, risk profile of the population and patient compliance with return visits.

In addition, if computer simulation models are to be part of a public health professional’s toolset, experience applying these methods to problems in order to develop the conceptual and methodological understanding is needed to frame population health through complexity and

system science. The interaction of only a few elements can quickly lead to great complexity, and too much complexity can overwhelm our ability to learn and understand systems. Therefore, in order to demonstrate the utility and cover the whole development process, I am purposely not taking the model to the full extent possible. I will keep the application of these methods at a fairly simplified or stylized level — not including every feedback loop or contributing factor, and omitting certain details. This is partly because it is beyond the scope of this DrPH dissertation but also because complexity arises very quickly from the combination and interaction of only a few elements and too much complexity can obfuscate our ability to see simple but important dynamics. Defining this scope was part of the challenge of this project (and that of any simulation model).

Another aspect worth mentioning at this point is that one of the benefits of a simulation model is not simply the resulting model, but the modeling process itself. Having to identify the critical elements, relationships, interactions, processes, and timing, as well as obtain useful information to characterize the problem and parameters or establish relative aspects of the problem in the absence of information, all contribute to learning about the problem and furthering scientific inquiry.

An agent-based, discrete event simulation model with the basic structure of the ABM-DES model of this dissertation has already been published in a book chapter (co-authored with two others), with other models addressing issues of health disparity (Kreuger, Flint MacBride, & Osgood, 2017). This model sought to characterize the dynamics associated with trust and oral health and the effects on oral health disparities.

This study will contribute to the body of literature on the application of complex systems methods to complex population health and health care problems. The work of this dissertation

represents the first time a complex systems approach is applied at both the individual (patient and dentist) and population levels to capture the progression of caries disease, and dentist productivity and use of risk and disease management approach to caries. While the study of multiple levels of influence and outcomes is quite common in simulation models, the ability to capture and connect information across these multiple levels is challenging and less common in studies of clinical practices or population health. Therefore, this project has some important and innovative contributions to the body of public health research and practice:

- 1) The simulation model explores dynamics across levels of influence – individual, both provider (productivity) as well as patient factors and population factors (oral health outcomes) and the interaction between the two.
- 2) The use of a *hybrid* simulation approach, which is a model that combines more than one simulation method. This allows me to leverage the strengths of each method and make up for any deficiencies inherent in the various methods. This not only provided experience with the three main simulation methods — agent-based model, system dynamics, and discrete event simulation — but it contributes a rare conceptualization and application of these methods. This kind of model is not only rarely used in public health but is also relatively uncommon in the broader simulation community across the many subject areas that use it.
- 3) To my knowledge, this is a unique application of this type of hybrid model to study the dental caries disease process, individual behaviors, and the dental care process. There are examples of system dynamics models modeling population-level interventions, and agent-based models of plaque, and Markov type models of dental visiting patterns, but none of the disease process, individual behaviors, care-seeking and dental process.
- 4) A thorough description of the model development process and the mechanisms underlying each part; this can be helpful to other novice modelers. From my own experience, it is rare that models provide details of the development process and decision-making or have enough detail that a user like me could replicate. If they are out there, they are rarely reported in the public health literature.

A quick note on nomenclature and language. System science often uses terms that may be familiar to the reader which have meaning and everyday usage in other disciplines. Often these are “terms of art” that in system science have specific or technical meaning. A glossary is included for many of these terms.

Landscape of this dissertation

Chapter 2: Literature Review To take a systems approach, it was helpful to get a broad picture of the epidemiology of caries, how our understanding of the etiology of caries has evolved, what we have known and for how long. This puts context around the resistance of the system to change, how much has changed, and how much has not. Also included is an introduction to the dental delivery system and workforce, its accomplishments and shortfalls, and the relevance of specific dental approaches to treatment and/or control disease. If the reader is already familiar with this information, jumping to chapter three may be in order.

Chapter 3: Systems Science Theory Understanding the limitation of current approaches to population health and health services can lead to an understanding of the need for systems science methods. In this chapter, I review some of the traditional health services and health disparities conceptual frameworks and models used to study health and/or dental care, and predictors of oral health and disparities. These are generally focused more on the user of services, the patient, and their health behaviors. I then focus on what we know about provider behaviors and different frames used to study their practices and adoption of new practices, knowledge, and innovations. All of these point to the need for dynamic theories about delivery system process and incentives, and ways of studying these issues. This chapter ends with an introduction to the system-science perspective and way of thinking and an introduction to complex systems methods. I apply systems thinking by formulating a causal map to elucidate the question of why dentists do not adopt a risk and disease management approach to care and what effect that has on population oral health.

Chapter 4: Methodology This chapter provides detailed information about the modeling process, including conceptualizing the problem and all the parts and submodels of the final

hybrid simulation model that was developed. This may feel more like a basic primer on modeling. Since this is the first time this modeling approach is applied to this problem, I erred on the side of being overly descriptive in the methodology section to allow someone with no experience in modeling to follow the logic of the model and building process. Such level of detail would have been helpful to me as I was learning.

Chapter 5. Results Results of the structured causal loop diagram and hybrid model simulation and sensitivity analyses. These results are not intended to be predictions of outcomes from the different approaches or to inform policy decisions per se, but to generate an understanding of the underlying system, and for consideration of the influence that certain changes could have on the system. Also, to offer the “look and feel” of models and the findings they can generate.

Chapter 2: Literature Review of Caries and Dental Care

In this chapter I will describe the epidemiology and public health impact of caries, and the multiple levels of complexity inherent in the nature of the disease as well as the system that cares for it. The high prevalence rates, the persistent disparities in disease and access to dental care have consequences across the life course. The financial cost as well as the human toll the disease takes call for new ways of looking at the problem and the system responsible for ensuring the oral health of the population.

Introduction to Dental Terminology

To begin, I will define terms relating to the disease and its epidemiology. First, it is important to differentiate caries disease from cavities. Tooth decay is a lay term that closely approximates dental caries, but it can just as well be understood to mean the result of the process as well. Caries is the name of a multifactorial and chronic disease process, much as diabetes is. In the same way we never refer to someone having “a diabete,” it is a similar misnomer to say that someone has a “carie.” Caries is different from diabetes in that it is also an infectious and transmissible bacterial disease. Caries is a pH-mediated disease process of the dental biofilm or plaque which, under increased exposure to dietary sugars, causes localized chemical dissolution of the tooth surface and structures (demineralization) to the point where the enamel becomes thin and eventually cavitates (i.e. caves in), leaving behind a hole commonly known as a cavity. A

cavity is therefore a symptom and a result of the disease process, a process I will discuss in detail later in this chapter.

Lesions are classified based on whether they are *cavitated* or *non-cavitated*. Lesions can also be *active* or *inactive*. An active lesion is one that is progressing, and an inactive lesion is one that has stopped progressing, also referred to as an arrested caries lesion. The earliest stage in which a lesion can be detected with the naked eye is often called a *white spot lesion (WSL)*. These are often referred to as *early enamel, initial* or *incipient lesions*. WSLs may not all be incipient, meaning “beginning.” Sometimes WSLs can arrest and become inactive, leaving behind a scar, so it is clinically meaningful to differentiate between active or inactive/arrested lesions (Fejerskov, Nyvad, & Kidd, 2015).

Several terms have been used to describe the presentation of the caries disease in infants and toddlers. As a nutrition counselor for the Women Infants and Children (WIC) program almost 30 years ago, we referred to the condition that could qualify a child for the program as “baby bottle tooth decay” or “bottle mouth”; it was also known as “nursing bottle caries.” In 1997 at a workshop organized by the Centers for Disease Control (CDC), the term “*early childhood caries*” was proposed for caries disease with rapid presentation and advancement in infants and toddlers. A primary definition was established at a NICDR² workshop in 1999 and a formal definition published in 2005 by the American Academy of Pediatric Dentistry (AAPD). Early childhood caries, also known by its acronym ECC, was defined as “the presence of one or more decayed (noncavitated or cavitated lesions), missing (because of caries), or filled tooth surfaces in any primary tooth in a child aged 71 months or younger” (American Academy of Pediatric

2. National Institute for Craniofacial and Dental Research

Dentistry, 2008; Drury et al., 1999a). One purpose of the definition was to move attention away from the bottle as the single cause of the disease and toward the multiple determinants understood to be involved.

Dental research uses several indicators to measure and describe the epidemiology of caries in the population, including prevalence and severity. The prevalence of caries, often referred to as “caries experience,” is measured by counting the number of decayed, missing (because of caries) and filled teeth and reported as dmft (for primary teeth) or DMFT (for permanent teeth), or sometimes just decayed and filled teeth (dft/DFT). Decayed teeth give a measure of “untreated decay,” while filled points to a history of decay and receipt of restorative care. The severity of the disease can be measured by the number of decayed and filled surfaces (dfs) for primary teeth and decayed, missing and filled surfaces (DMFS) in permanent teeth. The AAPD definition also differentiated severe ECC in children with “rampant” or “acute” patterns of decay to include any smooth surface lesion in children under three years of age. If over three, a child would be assessed with severe early childhood caries if they had one or more cavitated, filled, or missing smooth surfaces in primary maxillary anterior teeth, or a dmfs score of more than four, five, or six based on their years of age, three, four and five years respectively (American Academy of Pediatric Dentistry (AAPD), n.d.; Drury et al., 1999b). Of note is that most of these indices of caries do not consider the dynamic aspect of the disease and do not include initial lesions.

Although the oral health of the U.S. population substantially improved in the last 50 years (Dye et al., 2015a; US Department of Health and Human Services (DHHS), 2000), profound disparities persist. Almost everyone had experienced caries in the middle of the 20th century, with many affected teeth; today many, especially in the younger generations, have never experienced it, and when they do, fewer teeth are affected. In 2000, the U.S. Surgeon General

raised awareness of a “silent epidemic of oral diseases” that disproportionately affects poor children, the elderly, and members of racial and ethnic minority groups (Dye et al., 2003). Oral health is the most significant unmet health need of poor and racial minority children (Mertz, 2016) as well as adults (Andrews, 2015; Shartzter & Kenney, 2015). Caries is a prevalent, multifactorial, chronic, and mostly preventable disease that accounts for a substantial amount of the prevalence of poor oral health.

Oral Health Epidemiology

Disparities in oral health

According to the National Health and Nutrition Examination Survey (NHANES), dental caries affects a large number of Americans in all age groups. NHANES is a survey designed to assess the health and nutritional status of a large representative sample of children and adults in the United States. Measures of health are collected through interviews as well as physical exams, nutritional assessments, lab tests and DNA information. The 2011–2012 survey found that 23% of 2–5-year-olds had caries in primary teeth (Dye et al., 2015a), only a 1% drop from what it was over two decades earlier (24% in 1988 NHANES). Prior to 2012, there was a concerning increase in caries among preschool-age children from 24% in 1988 to 28% in 2004, even though rates in all other age groups declined during this same time period. The lack of improvement in caries among children sparked a renewed focus on this age group.

Early childhood caries can have a profound effect on a person’s oral health across their life, as it is often a determinant of caries and its severity later in life. Figure 1 shows the percentage of the population affected by caries by age (including treated or untreated disease). Since caries is not self-limiting, it continues to progress over the life course, affecting more teeth, more

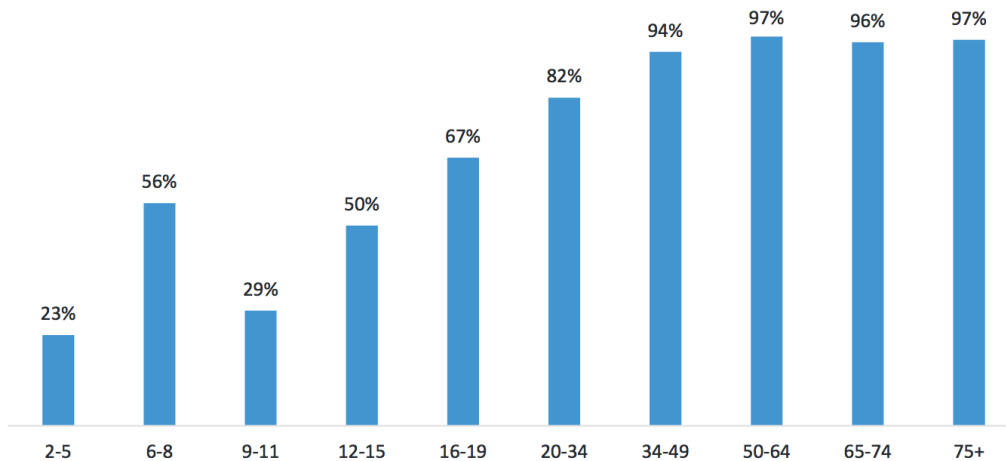

Figure 1. Proportion of the US population with caries experience (percentages for 2–5 and 6–8-year-olds reflect the percentages of individuals with caries experience in primary teeth; for ages 9 and above, percentages reflect the percentages with caries experience in permanent teeth) by age (years). From National Health and Nutrition Examination Survey, 2011–2012. National Center for Health Statistics, CDC as cited by Crall & Forest (James J. Crall & Forrest, 2018)

surfaces, and more layers of the teeth. It is, therefore, not surprising that the percent of the caries-affected population increases to over 90% in adulthood.

Ultimately, caries disease paired with lack of access to dental care can lead to the loss of all teeth, a condition known as edentulism. This condition has major impacts on the overall health of older adults. Studies have shown an association between tooth loss and cognitive impairment and onset of dementia, a decline in nutritional status and physical mobility, onset of disability and even premature mortality (Nowjack-Raymer & Sheiham, 2003; Tsakos, Watt, Rouxel, de Oliveira, & Demakakos, 2015). The percent of older adults in the U.S. who are edentulous declined in the last several decades from 29% to 24% to 19% (for 1988–1994, 1999–2004, and 2011–12 NHANES respectively). However, the extent of the improvement is lower for disadvantaged groups. More black adults were edentulous (29%) compared with white (17%) and Hispanic adults (15%). In both the 1988–94 and 1999–2004 surveys, about 40% or more of

adults over 65 that were low-income and those that had less than a high school degree were edentulous (Dye et al., 2007, 2015b).

The older adults in the 2011–12 survey would have been born post WWII, in the late 1940s, when the focus on caries and the protective role of fluoride was increasing along with federal investments into caries research and workforce development (i.e., dental schools). Fluoridation of public water systems first started in 1945 in Newburgh, New York, and Grand Rapids, Michigan. In the mid-1950s Crest marketed its first fluoride toothpaste with the famous slogan “Look, Mom — no cavities!” In 1948, President Truman established and funded a branch of the National Institutes of Health dedicated to dental research, the National Institute of Dental Research (later renamed the National Institute of Dental and Craniofacial Research in 1998).

With the introduction of fluoridated toothpaste and public water systems in the mid-20th century, the oral health of the U.S. population improved markedly. And for the last several decades, fewer children suffer the consequences of caries. In fact, about 50% of children reached adolescence caries-free in their permanent teeth. However, caries continues to be unequally distributed in the population. Low income, young and old, and racial/ethnic minority populations continue to bear the burden of disease, and more severe disease. NHANES data revealed that 80% of the disease was experienced by about a quarter of 5–17-year-old children, mostly from lower socioeconomic households (Edelstein, 2002; Kaste et al., 1996). Kaste et al. reported the difference in severity: the mean number of teeth affected by caries among children 5–17 was 2.8, but the mean of the group experiencing the most decay was 8.0 teeth (Kaste et al., 1996). These children in the tail of the distribution are fewer in number, but the most costly to public programs that are most likely to pay for their rescue-care as children, as well as for the associated medical and dental morbidities throughout their life course.

Disparities in access to dental care

It has already been demonstrated that a social gradient exists in children's oral health status and dental care utilization (Vargas & Ronzio, 2002). Despite advances in preventive oral technologies and other scientific advances that have led to remarkable public health improvements, as a society we continue to struggle with effectively allocating human and financial resources to reduce social disparities in oral health. When it comes to caries, the "inverse care law" operates at every age: Those that need care the most do not get it (Hart, 1971; Patrick et al., 2006; Vargas & Ronzio, 2002).

Disparities in access to dental care can be appreciated in the disparities of "untreated" dental disease that remains a serious problem among some income and race/ethnic groups. High-income children are twice as likely to have a dental visit than poor children (Manski & Brown Jr, 2007). At every age, the lowest income group consistently has the highest proportion of untreated caries. Children who have cavities and whose family income is at or below 200% of the Federal Poverty Level (FPL) have more decayed or filled teeth than those with income above 200% FPL (Vargas, Crall, & Schneider, 1998). Capurro et al. (2015) analyzed the income-related inequality trends in untreated caries across three NHANES surveys: NHANES I, II and 1999–2004. Inequalities persisted across the three surveys, and although there were reductions in the overall number and percent of children with untreated caries, rates of untreated cavities uniformly declined with increasing income, at all income levels (i.e., the slope of the disparities gradient changed little since the 1970s) (Capurro et al., 2015).

Disparities among racial and ethnic groups is also a problem. Data from 2011–12 NHANES reports significant differences in the rates of untreated tooth decay among racial and ethnic subgroups. Among the 2–8-year-olds, the rate of untreated caries among Hispanic and black

children is double the rate of non-Hispanic white children (about 20% compared to 10%). As children enter school, more receive needed care. However, black and Hispanic children still have about twice the rate of unmet dental care as white children (8% vs. 4%) (Dye et al., 2015a). Throughout adulthood the overall rate of untreated decay is higher at around 27%, with blacks and Hispanics still having the highest rates (42% and 36%, respectively) and whites and Asians the lowest (22% and 17%, respectively) (Dye et al., 2015b).

Non-Hispanic black and Hispanic children had fewer routine dental check-ups in the prior year than white, non-Hispanic children. More than half (54.1 percent) of non-Hispanic white children reported visiting dentists for routine check-ups once or more during the last year compared with 40.3 percent for non-Hispanic black children and 42.8 percent for Hispanic children (Soni, 2011).

On a positive note, ADA's Health Policy Institute recently reported a reduction in the prevalence of untreated caries by income level among children 5–18 from 23% in 1988–1994 NHANES to 18.2% NHANES 2011–2014. The differences were significant in the lowest income groups and among blacks and Mexican-Americans. Among the <100% FPL group, rates dropped from 32.8% to 24.8%, and for the 100–199% FPL group from 32.1% to 22.1%. Both blacks and Mexican-Americans saw improvements that brought their rates of untreated caries closer to what the overall population rates were in 1994 and 2004, 29% to 23% for blacks and 34% to 24% for Mexican-Americans (ADA Health Policy Institute, 2017d). The ADA reports recent increases in dental care use among children have been driven mainly by gains among those covered by Medicaid and CHIP. The gap in dental care use between low and high-income children has narrowed. Unfortunately, gaps for seniors has widened (ADA Health Policy Institute, 2017a).

In addition to income and race/ethnicity, other factors associated with inadequate dental access include age, the parents' education, and insurance status. Those less likely to visit a dentist are younger children, those with parents who did not complete high school, and those with no insurance or public insurance.

Age

Medical Expenditure Panel Survey (MEPS) 2004 data show that on average in the U.S. only 25% of children under age six visited the dentist compared to 59% of children 6–12 years old. (Manski & Brown Jr, 2007). The California Health Interview Survey shows a better picture: At least in California, 65% of children under five reported visiting the dentist within the last year, and 98% of children 5–11 years old had. But it is also the case that parents are not aware of the preventive guidelines for a child to visit the dentist by one year in age or first eruption of teeth. This might be because neither do many primary care providers, and often Medicaid programs did not support the recommendation either. In California, for years the CHDP Program (CA's EPSDT) recommended a visit at three years of age but did not require it. This recommendation was changed only recently to recommend a dental visit by one, and required by age three, to align with AAP and AAPD guidelines. The National Survey for Children's Health reported in 2003 that only 10% of children aged one year, 24% of 2-year-olds, and 51% of 3-year-olds were reported by parents to have had a preventive dental care visit in 2003 (U.S. DHHS as cited by Edelstein in Edelstein & Chinn, 2009). Very few parents report unmet needs at one to three years of age, which authors suggest is because they are generally unaware of the professional recommendation for early preventive care.

Education

Children whose parents did not attain a high school degree were less than half as likely to obtain a dental visit in 2004 as children whose parents are college graduates (25% vs. 54%) (Edelstein & Chinn, 2009). Adults without a high school degree were also less likely to have a dental visit in 2004 than college graduates, 20.8% vs. 53.6% (Manski & Rohde, 2017).

The rate at which children visited a dentist for routine dental check-ups was also related to the educational level of parents. Children whose parents had some college education received routine dental check-ups at higher rates than children whose parents had completed high school education or not completed high school (55.7 percent versus 41.5 percent or 36.2 percent) (Soni, 2011).

Duijster et al. (2014) suggests the link between education and childhood dental caries is mediated through poorer family organization, lower levels of social support, and the mother's lower dental self-efficacy, and an external dental health locus of control. These in turn are associated with poor oral hygiene behaviors and linked to higher levels of childhood caries.

Mother's oral health

The mother's oral health and dental care has been shown to have an important influence on the oral health of her children. Mothers who rate their oral health as excellent were three times more likely to take their child to a dental visit (Milgrom et al., 1998). Additionally, mothers with moderate to high dental fear were less likely than mothers with low dental fear to have a dental visit. Castilho et al. (2013) concludes that parental oral health habits influence the entire family, and it is equally important to provide to address both parents and children with preventative care and lifestyle habits that support oral health. Finlayson et al. (2017) found vertical transmission

can begin as early as during pregnancy or soon after delivery, and that interventions pre- or post-birth reduce MS transmission and caries in the infant (Finlayson et al., 2017).

Insurance

Cost and the ability to pay for dental care are overwhelmingly reported to be the reasons for not visiting the dentist. Therefore, insurance becomes an important predictor of use of dental care: 61% of parents reported either that they did not obtain care because they did not have insurance or because dental care “costs too much.” Access barriers are also evident, as one in four parents (23%) reported either that they “could not get a dental appointment” or that they could not find a dentist who treated children.

Poor children generally make routine dental check-up visits at lower rates than children from high-income families. Soni et al. (Soni, 2011) found that almost two-thirds (63.9%) of children from high-income families reported at least one routine dental check-up visit during the previous year as compared with 36.9% of children from poor families (Soni, 2011).

Generally, uninsured children receive routine dental check-ups at lower rates than children who were covered by public programs, and those with private insurance have the highest rates of dental check-ups (25.9 percent versus 40.5 percent and 56.5 percent, respectively) (Soni, 2011). In 2004, 57% of those with private dental coverage had a dental visit, 32% with public dental coverage and 27% with no dental coverage. Overall, children with private dental coverage were twice as likely to have had a dental visit as children with no dental coverage. (Manski & Brown Jr, 2007).

It has been suggested that one reason for the differences in untreated caries across race and ethnic groups is that white children are more likely to have private dental insurance coverage than children in other ethnic/racial groups. In fact, non-Hispanic black and Hispanic children

were more likely to have public dental coverage and less likely to have private dental coverage in 2004 than white non-Hispanic children or children of other race/ethnicity categories. Poor, less educated and racial/ethnic minority populations are less likely to secure dental insurance through their employers and more likely to be covered by Medicaid if they live in a state that provides that coverage.

The picture is improving in the U.S. for children, especially with the expansion of Medicaid and the requirement in ACA for health plans to include a dental option for children. The 2000–2015 Medical Expenditure Panel Survey Data from MEPS reports that in 2015 only 10.3% of children had no form of dental coverage, which is the lowest level ever, down from 15.8% in 2010; among adults, one in three had no coverage (ADA Health Policy Institute, 2015). Recent increases in dental care use among children have been driven mainly by gains among children covered by Medicaid and CHIP. Because of this, the gap between income groups has also narrowed in the percent of children who visited a dentist in the prior 12 months. In 2010, more than 80% of low-income children with health insurance — whether Medicaid or private insurance — had a dental visit within the past 12 months, compared to half of low-income, uninsured children. In 2015, MEPS reports that 48% of children had a dental visit compared to 42% in 1996. Though Medicaid and CHIP cover comprehensive dental benefits for children, 30% of children with private health insurance are still uninsured for dental care (Kaiser Commission on Medicaid and the Uninsured, 2012).

Among adults overall, 52% indicate that they visit the dentist every six months. However, only 23% of those Medicaid-enrolled adults visited the dentist every six months compared to 60% of adults not enrolled in Medicaid. The ADA reports that about 50.6% of Medicaid-enrolled children visited the dentist in the past six months, compared to 69.0% of non-Medicaid-enrolled

children. Twice as many Medicaid enrollees have not visited the dentists for several years compared to non-Medicaid adults and children. Lack of coverage for many dental services is the most prevalent reasons why Medicaid-enrolled adults and children are not planning to visit the dentist in the next year as well as difficulty finding a dentist that accepts Medicaid patients. There is evidence that expanding dental benefits in Medicaid is associated with an increase in dental care utilization. Other interventions, such as increasing reimbursement rates, reducing administrative burdens to improve provider participation in Medicaid and increasing patient outreach, have produced positive results in dental utilization (Yarbrough, Nasseh & Vujicic, 2014).

Medicaid and visits to dentists

One in three children aged 2–18 enrolled in Medicaid had untreated tooth decay, and one in nine had untreated decay in three or more teeth (GAO, 2008). The lack of adequate dental treatment may affect children’s speech, nutrition, growth and function, social development, and quality of life (US Department of Health and Human Services (DHHS), 2000). In spite of these significant problems, according to MEPS, only about 25% of children under the age of 6, 59% of children ages 6–12, and 48% of adolescents ages 13–20 had a dental visit in 2004 (Institute of Medicine and National Research Council, 2011; Manski & Brown Jr, 2007).

Lu et al. (2007) found that both race and income play roles independent of private insurance status. Poor and minority children were less likely to receive preventive dental care, even when insurance status was considered. Isong et al. found that in 1999, 58.9% of the observed disparities were explained by insurance only, whereas both insurance and poverty status explained 90.3% of the observed disparities (Isong et al., 2012).

Caries is both a transmissible and chronic disease that progresses over the lifespan. The oral health condition later in life described above results from a bacterial disease that starts early in life, likely with the emergence of the first tooth (or teeth). It provides a useful application of life-course health-development principles. Early-life exposures to caries causing bacteria during the sensitive first two years of life will set the stage for a person's oral-health life trajectory, and the cumulative effect of these over time can influence future health. In addition to contextual factors related to the family, neighborhood, and community that determine an individual's experiences, individual risk and protective factors will also affect their health trajectories (James J. Crall & Forrest, 2018).

These disparities are of consequence to an individual's life course. Childhood socioeconomic disadvantage predicts adult oral health, and caries in childhood has life-long impacts on oral health. Data from one of the few oral health longitudinal study is from a birth cohort study of individuals born in Dunedin, New Zealand, that includes data spanning the period from perinatal and up to 32 years, at two- to three-year intervals. Broadbent (Broadbent, Thomson, & Poulton, 2008) reports on the individual caries trajectories for 955 individuals using their scores decayed, missing or filled surfaces (dmfs and DMFS³). Using a latent class analysis, he groups individual trajectories and reports that three very distinct trajectories emerged (see Figure 2), which diverge with increasing age (Broadbent et al., 2008). Another analysis by Thomson et al. (2004) reports that socioeconomic status (SES) at age five resulted in higher mean DFS scores (Decayed or Filled Surfaces) and tooth loss by age 26 after controlling for childhood oral health. A similar pattern emerged among those with greater caries experience at

3. dmfs is used for primary or baby teeth, DMFS for permanent dentition.

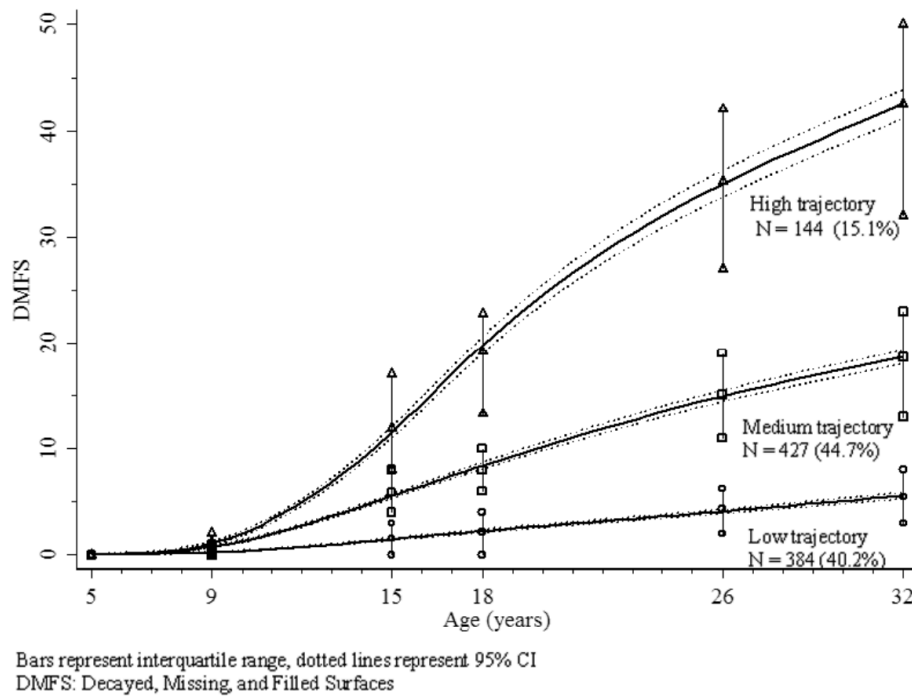

Figure 2. Trajectory plot of mean DMFS scores for three-group caries trajectory analysis model. From (Broadbent et al., 2008)

age five, after controlling for SES. In addition, they observed that upwardly mobile individuals, who were able to improve their SES over that of their parents, came closer to the trajectory of those who started in a higher socioeconomic group (Thomson et al., 2004). This provides a strong case for early oral health intervention. As I will discuss next, the cost of the disease and of not addressing the risks and disease in high-risk populations is borne somewhere in the system.

The Cost of Caries

As with many other health issues, if we do not intervene early in life and prevent, we pay more to treat the consequences later. Caries results in a monetary cost as well as a human cost.

Dental expenditures

Total spending on human dental services in the U.S. was \$124.4 billion in 2016. Relative to overall national health spending, dental services account for about 4% (3.7%) (Centers for Medicare & Medicaid Services (CMS), 2016, 2017). As a percentage, it seems like a small amount, but compared to other single organ or disease spending, it is not (Bailit & Beazoglou, 2008). To put the dental cost of \$124.4 billion in perspective, in 2015 the medical cost of coronary heart disease was \$89 billion (Nelson, Whitsel, Khavjou, Phelps, & Leib, 2016) and for all types of cancer \$80.2 billion (The American Cancer Society, 2018). The key difference is that over half the population receives dental care whereas relatively few people receive care for heart disease or cancer (Bailit & Beazoglou, 2008). It is also interesting to note the rate of increase: the cost of CHD increased \$5.4 billion in eight years (from \$83.6 billion in 2007 to \$89 billion in 2015) while spending on dental services increased \$30 billion in the same period (from \$98 billion in 2007 to \$119 billion in 2015).

The sources of spending on dental services have changed over the last 50 years. While private out-of-pocket funds used to pay for dental care almost exclusively, after the proliferation of private dental insurance spending shifted from out-of-pocket to insurance. Medicaid has represented a small percentage of spending since its inception, increasing from only about 4–5% before 2010 and the expansion of Medicaid with the Affordable Care Act to 10% in 2016. In 2016, employers, individual patients and the government were the primary payers of dental services, spending 46%, 40%, and 10% respectively (Centers for Medicare & Medicaid Services (CMS), 2016). Since most states do not provide adult dental benefits, the 10% mostly covers children under 21 who are entitled to dental services by law, and some with special health care needs who might also qualify.

In a recent study involving high-expense Medicaid children ages 0–6 in Washington State Dental, the sample of 345 children had at least one dental procedure (preventive or diagnostic). The researchers found that 9% of children incurred 64% of total expenses for the entire group. Unfortunately, parents are often not aware of the dental benefits under Medicaid, and parents' lack of awareness was associated with higher dental expenses (Churchill, Williams, & Villareale, 2007).

Emergency dental care and hospitalizations

The lack of access to dental care especially for those covered by Medicaid or uninsured results in inefficient and costly care. Dental pain and abscesses often drive many to access care, in the emergency department (ED), which is a known mode of entry into the dental care system for children younger than six years and those without a usual source of dental care. Individuals with Medicaid or without insurance make up nearly 75% of those using hospital-based EDs for dental reasons, and 80% of emergency dental patients at university-based dental clinics (Meyer et al., 2017). The increase in use of EDs for nonurgent and nontraumatic dental conditions (NTDCs) in the United States is well documented (Wall & Vujicic, 2015). These visits are largely a result of avoidable complications of caries yet account for more than 1.3 million ED visits per year and \$1 billion in spending nationally (V. V. Allareddy et al., 2014; Wall, Thomas P. & Vujicic, 2015). This is particularly an issue among low-income and rural populations for whom accessing care in traditional offices presents significant barriers (Skillman, 2010, Seu, 2016, and Shortridge as cited in Rowland et al., 2016).

Dental treatment at EDs is costly — significantly more expensive than a general practice dental visit (Rowland et al., 2016). In 2014, there were 2.2 million reported hospital emergency department visits for dental conditions in the United States that cost a total of \$1.9 billion.

Since a small proportion of children bear the burden of disease, most of whom are low-income and/or minority children, it follows that Medicaid pays for a fair share of those visits. Rampa et al. (2016) studied trends in hospital-based ED visits involving dental conditions in California between 2005 and 2011. In addition to an overall increase in the proportion of dental-related visits, they found a decline in the proportion of ED visits covered by private insurance and an increase covered by Medicaid. Indeed, Medicaid was most frequently reported as the primary payer for patients, 35%, in 2011 (Rampa et al., 2016). Another study of dental-related ED use among children under 21 years across the U.S. found that Medicaid paid for 42% of 215,073 dental-related ED visits in 2008, and 23% were uninsured. Half of these visits included a caries diagnosis (V. Allareddy et al., 2014). ADA published recent estimates for 2014, after implementation of ACA and Medicaid expansion, and found that Medicaid paid for 70% of emergency department visits for dental conditions among children, and only 39% for adults (ADA Health Policy Institute, 2017b).

The irony of such high cost is that EDs are generally inappropriate places to receive dental care (Cohen et al., 2008), and most care delivered in the ED is primarily aimed at treating symptoms rather than the cause of the underlying caries disease. Staff typically have limited training to diagnose and treat dental conditions. Therefore, nearly 90% of patients visiting the ED with a dental problem receive no dental procedures; usually, they get only prescriptions for antibiotics and pain management (Davis, Deinard, & Maïga, 2010).

ED visits for dental problems have increased disproportionately over the last decades compared to other conditions, and most of the patients have been young adults or young children. Nalliah et al. (2010) reports that in 1994, 60% of ED visits were trauma-related

compared to 2006, when trauma was the cause of only 27% of pediatric emergency dental visits and 73% were for some type of dental infection.

Dental care under general anesthesia

Providing dental treatment under general anesthesia (GA) in a hospital setting is another costly model of delivery care that also does not address the underlying causes of disease. Young children under five years of age with rampant decay are often referred to a hospital setting to receive restorative treatment under general anesthesia. Children 2–5 who have difficulty cooperating with the dentist, sometimes not even allowing X-rays to be taken much less the required restorative treatment performed, need to be treated under general anesthesia at a hospital.

A study of caries-related ED visits in New York found that charges for EDs and ambulatory surgery facilities for children younger than six years increased substantially from 2004 to 2008. They report a 40.3% increase in the number of patients treated under general anesthesia during the five year of the study (Nagarkar, Kumar, & Moss, 2012).

The majority of dental GA candidates for ECC are children who are otherwise healthy. (Ramazani, 2016). Rashewsky et al. (2012) reported the average cost per GA case in a hospital setting was \$7,303, which compared to an average cost of \$414 when the same procedure was performed at an outpatient facility. Most of the cost of treatment in an operating room does not accrue to the “dental spending” category, making the impact of this category of spending difficult to track and likely underreported. There are several figures quoted on the costs ranging from \$2,000 to \$10,000 per case of GA. A study in Iowa found that only 2% of Medicaid-enrolled children under six years of age who received any dental service accounted for 25% of spending on dental services for this age group, including hospital and anesthesia care. The most

frequent type of procedure was stainless steel crowns (SSCs), with an average of almost six per case (Kanellis, Damiano, & Momany, 2007). In addition, this costly option also carries with it the inherent risks of general anesthesia (H. H. Lee, Milgrom, Starks, & Burke, 2013; Slayton, 2015).

Similar to care received in the ED for dental caries, treatment under GA does little to curtail the behaviors that led to the level of decay at such a young age. Klinke et al. (2014) report that while treatment reduced plaque and bacterial counts immediately following a procedure, one-third of children developed lesions within one year of treatment. Furthermore, scores of lactobacilli before treatment were predictive of caries relapse, and nutritional and oral habits changed only slightly. Another study reports that on follow-up, 91% of children treated under anesthesia had decay (EzEldeen, Gizani, & Declerck, 2015).

There is evidence to suggest that timely preventive care can prevent the need for care in the emergency department or under general anesthesia at either hospitals or ambulatory surgery facilities. But often public programs struggle to keep up with the demand for treatment. Therefore, less is allocated for prevention. In California, for example, Denti-Cal spends just 14% of its \$1.3 billion to budget on preventive check-ups and 86% to drill, fill, and extract teeth.

Effect on other health conditions

The Surgeon General's report (2000) reiterated the importance of oral health for overall health. Caries shares risk factors with other noncommunicable diseases such as cardiovascular disease, diabetes, respiratory disease, and cancer. State-level association have been reported between the proportion of adults who visited a dentist in the past year and those reporting fair or poor overall health in the same state. Furthermore, evidence is emerging that treating oral diseases can lead to reduced expenditures for patients and states (Chalmers, Wislar, Boynes, Doherty, & Nový,

2017). Kaiser Permanente reports reduced spending on chronic diseases for patients who receive dental care.

Effect of disparities on military readiness

This is one area where the “silent epidemic” becomes not so silent. Decay is usually considered an individual’s cross to bear until someone else has to pay for the “rescue care.” Though not so visible to most civilians, the preparedness and overall health of our military also suffers.

Recognition of the disparities discussed thus far can be traced back to concerns for the oral health of the nation’s military back in the 18th and 19th centuries. Army recruits who did not have four front teeth with which to tear open gunpowder packages were disqualified from enlisting during the Civil War. This is the origin of the 4-F designation (missing four front teeth) (Reilly, 2016) still in use to refer to disqualification for medical, dental or other health reasons. At that time, dental health was considered a personal responsibility, however, and the government was limited in its ability to provide a solution until the 20th century with the creation of the US Army Dental Corps (IOM (Institute of Medicine), 2011). Oral health has remained a concern for the military as it limits the pool of eligible recruits or deployable soldiers, even as recently as deployments during the Iraq and Afghanistan conflicts. A study of 1994–1998 data found that over 50% of recruits presented with a level of disease that made them unfit to be deployed (York, Moss, & Martin, 2008). In 2008, 40% of the Department of Defense (DoD) Selected Reserve troops were classified as unfit for duty due to lack of “dental readiness”(Military Health System Communications Office, 2017). After putting a new dental program in place, the proportion of unfit troops went down to 10% of all military reservists. This included adding permanent health and dental benefits for the National Guard in the 2006 legislation (Fryer, 2005).

The problem among military recruits, and reservists in particular, reflects the growing income inequalities in the U.S. and resulting lack of access to dental care over the last several decades. In addition, since the military is an attractive career option for those with fewer opportunities, those from lower-income families are more likely to enlist (Lutz, 2008). It also shows what is possible when we allocate resources to provide access, though in this case it came with the requirement to access the care offered, something that as we will see is not within the toolkit (purview) of most dental programs.

The human cost of caries

Over a decade ago the nation put a face to this “silent epidemic” of disease and untreated decay. In 2007, 12-year-old Deamonte Driver died in a Maryland hospital after bacteria from a dental infection spread to his brain. Deamonte’s surgeries and weeks of hospital care generated medical bills of \$250,000, but his life and the expenses could have been spared had he been able to afford an \$80 tooth extraction, and had his mother been able to find a dentist that would attend to him. Though he was a Medicaid beneficiary entitled to dental services, Deamonte had never received any kind of preventive care. At the time of his infection, his mother was struggling to find a dentist to treat his younger brother who also had abscesses in several teeth and “was always complaining his teeth hurt” (Otto, 2007). This story, told and retold around the country, points to the shortcomings of a complex dental-care delivery system in its ability to control a preventable disease and meet population dental treatment needs, and especially those of young children. Many of us that are educated, employed and insured are shielded from the consequences of ECC that millions of children experience annually. There is also the risk of death that results from attempts to treat this most common childhood disease — local anesthesia overdose, sedation or

general anesthesia mishaps and even choking (Carol, 2016; Casamassimo, Thikkurissy, Edelstein, & Maiorini, 2009).

Effect on child development and learning

Knowledge of the impact of early childhood caries on children's physical, emotional and intellectual development is fairly fragmented. Episodic pain is consistently reported, with up to 20% of preschoolers experiencing dental pain (Casamassimo et al., 2009; Tickle, Blinkhorn, & Milsom, 2008). Casamassimo reports that the effect of ECC pain on distraction from learning and school performance, while not generally measured, is significant. One study reported that more than 1 in 10 school children experience tooth pain. Anecdotally, schools nationwide report that dental problems significantly contribute to learning difficulties, especially among low-income populations. A study in Michigan documented loss of sleep, inability to concentrate in school and absences from school all caused by dental caries-related pain (Casamassimo et al., 2009).

Early childhood caries interferes with a child's ability to eat, sleep and learn. Parents of children seeking dental care at the emergency department report that 19% of the children experience interference with play, 32% with school, 50% with sleeping and 86% with eating (Edelstein, 2006 as cited by Casamassimo, (2009). Caries has been linked to failure to thrive in some low-income children (Clark, 2006 as cited by Casamassimo, (2009). Caries affects socioemotional development and social engagement, attention, and absenteeism from school. A California study found that students had to miss an estimated 874,000 days of school each year because of dental problems, costing schools over \$29 million resulting from a reduction in the average daily attendance rate (Pourat & Nicholson, 2009). Another study found that California children who reported having recent tooth pain were four times more likely to have a low grade-

point average (Mulligan, Seirawan, Faust, & Barzaga, 2011). Garg et al. (2012) found a relationship between the number of decayed and filled teeth and the level of academic performance of preschool and elementary school children. Children are less able to identify and communicate dental pain (P. R. Brocklehurst, Ashley, & Tickle, 2011) so it often expresses itself in behavior problems, which resolve following dental treatment.

Furthermore, children with unmet dental health care needs are more likely to experience other physical development problems that also translate to a loss of school days, restricted activity, and diminished ability to learn. As disadvantage tends to accumulate, poor children experience nearly 12 times as many restricted activity days from dental diseases as do children from higher-income families (U.S. General Accounting Office (GAO), 2000).

One can appreciate how health disadvantages compounded with learning challenges and shortfalls will show up later in life in increased caries disease burden which will then affect workforce participation and absenteeism. All of this translates to a high cost for society including healthcare systems (Casamassimo et al., 2009), families (Mattila, Rautava, Sillanpaa, & Paunio, 2000), and individuals.

Developing a simulation model of disease in a population required me to journey into a deeper understanding of the underlying mechanisms. A historical perspective on cariology⁴ discoveries and chairside applications shed light on the dissemination of innovations (or lack thereof) in the practice of dentistry, commensurate with the evidence on the nature of caries disease. In this section, I will review the etiology and pathology of caries disease. I will then discuss the slow paradigm shift that is occurring in dentistry away from a restorative “drill and

4. The study of dental caries and cariogenesis.

fill” surgical tradition towards a risk-based disease management approach to caries. I will argue that most dental practices and dental care system drivers do not effectively consider the bio-physiology of caries in clinical decision making, treatment plans, or reimbursement structures. Lastly, I will discuss how the qualitative aspect of dental practice could affect the value proposition of the dental care delivery system, including its effect on productivity and capacity.

Caries Etiology

Caries etiology is currently understood as the complex interaction of multiple endogenous causal factors. This understanding has evolved over the last several centuries, and though it has significantly impacted the field of cariology and perhaps public health dentistry, it has had minimal influence on the practice of dentistry as a whole. This is especially true when contrasted with the impact of innovations in drilling and restorative technologies. After review of many articles and textbooks, it helped me understand the etiology of caries as the disruption of two physiochemical processes in the mouth:

- 1) microbial homeostasis in the “biofilm”, and
- 2) mineral homeostasis between the tooth and the “oral fluid.”

Disturbance of the microbial homeostasis

Microbial acid production in plaque

Some experts have referred to caries as a disease of the oral “*biofilm*.” Biofilm is a community of microorganisms living in organized structures at the interface between solid (tooth) and liquid (oral fluid) (Usha & Sathyanarayanan, 2009). Most people know this as dental plaque. Environmental changes within the oral cavity affect the dynamic ecology and structure of this biofilm. Cooperation characterizes these bacterial colonies, with a complex interaction of

synergistic and antagonistic relationships that under normal circumstances create a physiological equilibrium of good and bad bacteria. Disturbances in the environment, such as a severe and persistent drop in pH, can shift this equilibrium. In an acidic environment cariogenic bacteria flourish, and good bacteria cannot and perish. If saliva cannot buffer this increasingly acidic environment, a vicious cycle that favors more cariogenic bacteria over more innocuous or protective bacteria begins and persists.

There are reports of 500 and 700 types of organisms inhabit the oral cavity (Aas, Paster, Stokes, Olsen, & Dewhirst, 2005; Fejerskov et al., 2015; Schuster, 1999). The *Streptococcus* species is thought to be among the initial colonizers of the tooth surface, as they have the ability to create substances that help them stick to the tooth. *S. oralis*, *S. sanguis*, and *S. mitis* are some of the early colonizers; *S. mutans* normally comprises only about 1% of the early colonizers. When biofilm bacteria metabolize fermentable simple sugars in the diet, they produce acids as a byproduct. Normally the oral fluids and saliva have the ability to buffer this acid. However, if the frequency and intensity of the pH fluctuations outweigh the buffering capacity of the oral fluid, the physiologic balance in the microbial colony is likely to change. A continuously acidic environment (e.g., <5.5 pH) will favor bacteria that can at least tolerate, if not thrive, in low pH environments. *Streptococcus mutans* and *lactobacilli*, two species believed to be mainly responsible for caries, are not only aciduric (i.e., acid-resistant), they are acidogenic (acid-producing). Though they may have started as a very small proportion of the bacterial colonies, this environment allows them to proliferate in large numbers, while other bacteria cannot survive or reproduce. This growth of acidogenic bacteria means local acid production continues to increase, ensuring a propitious low-pH environment for further growth. The result is that such bacteria predominate in mature biofilm.

The ability of *S. mutans* in particular to adhere to the surface of a tooth is part of what makes it highly cariogenic. It produces a slimy, glue-like substance, extra- and intra-cellular polysaccharides (EPS and IPS) that help it anchor to the (pellicle on) the tooth surface, creating a matrix that provides attachment opportunities and structure. This allows additional organisms, like *Lactobacilli*, to attach and increase the biofilm bulk. On its own, *Lactobacilli* would not be able to firmly attach to the tooth and would be washed away by saliva. This group of streptococcal species that are the main contributors to caries, including *Streptococcus mutans* and *Streptococcus sobrinus*, are often not differentiated in laboratory testing and for clinical purpose are considered together as a group and called mutans streptococci (Balakrishnan, Simmonds, & Tagg, 2000).

Arrival at our current understanding of caries disease followed several paradigms of the oral ecology and dental plaque. Surprisingly, while advances have unveiled greater levels of details about the organisms, the structures they form, and the complexity of the multiple factors involved, some of these basic concepts have been known for more than a century. This knowledge should have made a substantial impact on dental practices, but that is not the case; it has had minimal influence on how dentistry treats the disease even today. The failure to translate this knowledge into dental practices is one of the contributing motivations for my research.

W. D. Miller first postulated the “chemicoparasitic” theory of caries in 1881, which stated that *any* salivary microorganisms in the mouth that could metabolize dietary starch and produce organic acid was responsible for the decalcification of the tooth structure. Over the next century others built on this theory. The work of Black and William (in 1898) (Suddick et al., 1990 cited by Usha & Sathyanarayanan, 2009) explained that it was microorganisms in “dental plaque” on the tooth surface that caused tooth dissolution, not just bacteria present in the oral cavity.

Keyes and Fitzgerald made several contributions to our understanding of caries etiology. They proved that specific microorganisms such as Streptococci, Lactobacillia, and Actinomyces in dental plaque had a role in the caries process. In the 1960s Keyes proposed three factors essential for caries to develop: a host (tooth and saliva), bacteria (plaque and its microorganisms) and a substrate (carbohydrates and sugars). Famously known as Keyes' triad, these factors are illustrated as a Venn diagram of overlapping circles, the center of which represented caries occurrence (Keyes, 1962). Some 20 years later Newbrum contributed a fourth factor, time, recognizing that the frequency and duration of the interaction of the other three factors are important. This pointed to the importance of the frequency of sugar consumption by the individual as a factor that could be targeted. It also framed caries as a chronic disease that takes time to detect clinically (Ferreira-Nóbilo et al., 2014). Last but not least, it was also around this time that Keyes and Fitzgerald postulated caries was a transmissible, bacterial disease (Usha & Sathyanarayanan, 2009) following controlled trials with rats.

This reductionist view suggested that the control of any of these factors would suffice to prevent the disease. Research has proved it is not sufficient.

The role of sugar – sucrose metabolism by *S. mutans*

This microbial context is helpful to understand the cariogenic role of dietary sugars, and sucrose in particular. Sucrose is more easily fermentable than other starches (with greater acid disturbance) and provokes *S. mutans* to synthesize the cellular polysaccharides. IPS gives the bacteria a way to store sugar, which it can metabolize later during times of nutrient deprivation. This prolongs the acid exposure around the tooth, even in the absence of dietary sugar.

Ecological studies initially shed light on the connection between caries and the consumption of sugar by looking at:

- 1) changes in diet after the introduction of new products such as sugar,
- 2) changes in diet due to temporary deprivation during war times, and
- 3) comparison of diet content and caries prevalence across countries and population groups.

Sugar was introduced in Europe in the late Middle Ages, but for the next few centuries remained a product accessible only to the rich. Hence patterns of caries were the reverse of what they are nowadays: The rich were at higher risk of dental disease. Foreign ambassadors traveling to England told of the black and rotten teeth of Queen Elizabeth I (1533–1603), who was sometimes difficult to understand because she was also missing some teeth. Fauchard and Berdmore reported in the mid- to late 1700s that “where sugar, tea, coffee and sweet meats are used in excess, the people even at an early age are remarkable for the badness of their teeth.” (Fauchard, 1746, and Berdmore, 1769, as cited by Fejerskov, Nyvad, & Kidd, 2015). Ecological studies as early as the 1930s showed differences between Kenyan tribes, with higher caries rates among the Kikuyu, who had carbohydrate-rich diets compared to the protein-rich diets of the Maasai (Orr, 1931 as cited by Fejerskov et al., 2015). For other populations, their closeness to or introduction of a “Western diet” higher in simple sugars has been correlated to an increase in caries. For example: among Inuit Eskimos living closer to trading posts (Price, 1936 as cited by Fejerskov et al., 2015), island inhabitants following settlement of companies or workers with Western diets (Sognaes, 1954 as cited by Fejerskov et al., 2015), or remote areas gaining access through new highways (Roos, 1962 as cited by Fejerskov et al., 2015). Restricted access to food in general, but especially sugar and sweets during and after both world wars, has been associated with distinct reductions in caries prevalence in children. This was observed in Basel, Switzerland, where the supply of sugar went down from 40kg to 16kg per person per year during

World War II, while the number of caries-free children increased from 2% to 15%. After the war sugar became freely available again, and this trend reversed. Similar trends were observed in Japan, Denmark, Finland and Norway Norway (Fejerskov et al., 2015; Sognaes, 1948; Takeuchi, 1961; Toverud, 1957)

Before the use of fluoride was introduced, the impact of diet and caries was clear. Caries prevalence among 12-year-olds was related to the sugar supply per capita in 47 countries, and the severity of disease was related to the level of sugar consumption. A mean DMFT of 1.2 (± 0.6) in countries with lower consumption of sugar per person per year ($< 18\text{kg pp/year}$) compared to a mean DMFT of 2.0 (± 0.7) in 21 countries with sugar supply between 18kg and 44kg, and 4.0 in 10 other countries. Seven countries where sugar supply exceeded 44kg per person per year had a mean DMFT of 8.0. After the introduction of fluoride this relationship was slightly confounded (Fejerskov et al., 2015), but sugar is still understood to be an important contributor of the cariogenic process (Lingström et al., 2003).

While Miller thought starch was more detrimental than simple sugar, several human experimental studies have shown that simple sugars, especially sucrose, tend to produce quicker and greater drops in pH that last longer and are harder to bring back to neutral than complex starches. The famous Stephan's curve shows the drops in pH following intake of sugars at various time intervals. A normal pH above 6.5 will quickly drop to around 4.5 following a meal or snack with sugars. If the interval is long enough, the saliva can restore balance back to the 6.5 pH level. However, frequent consumption of sugary snacks or drinks can keep the pH around the critical pH range of 5.5–6 (van Loveren & Lingström, 2015). Two other important human experimental studies, the Vipeholm study (1945–1952) at a mental institution in Sweden (Gustafsson et al., 1953; Krasse, 2001) and the Hopewood study (in 1942) at a children's home

in Australia (Robert Harris, 1963) proved a definitive link between dietary sugars (quantity, quality, and frequency) and the incidence and prevalence of caries.

Research in the last part of the 20th century through the present day has provided more detail on the quantitative and dose response relationship between sugar, microbial colonies, and caries, along with differences based on demographics and oral hygiene habits. A recent systematic review of the relationship between caries and sugars was conducted by Moynihan and Kelly (2014) found that 42 of 50 studies in children reported at least one positive association between measures of daily total, free or added sugars and caries. Sheiham and James (2014) examine the quantitative relationship between sugar intake and the development and the life-long burden of dental caries. They find a robust log linear relationship between caries and sugar intakes from 0% to 10% of energy (E) intake. Less than 10%E is the current WHO guideline for sugar intake. Sheiham found that 10%E was enough to induce a costly burden of caries, and suggested that public health goals for sugar intake should ideally be <3%E, with <5% being a more pragmatic goal, even when fluoride is widely used (Sheiham & James, 2014).

Disturbance of the mineral homeostasis

The balance of minerals between the crystals that compose the tooth enamel and the oral fluids is the other equilibrium involved in caries. Though chemical in nature, this balance is directly affected by the byproducts of the biofilm organisms. It is important to understand that there is a constant process of minerals flowing out of the tooth structure and into the oral fluid (demineralization), and if the oral fluid gets oversaturated, minerals are depositing back into the tooth structure (remineralization). This is affected both by the relative saturation of minerals in the tooth and oral fluid, and the pH in the oral cavity. The tooth enamel is primarily made of hydroxyapatite (HA) crystals containing calcium and phosphates; the oral fluid has a reservoir of

calcium, phosphate and fluoride minerals. At a pH below 5.5–6, the mouth has reached a critical state where enamel crystal starts to dissolve in an attempt to maintain the balance and restore saturation to the oral fluid; the tooth will dissolve into either saliva or plaque. In fact, similar to the Richter scale for earthquakes, the solubility of HA increases about 10-fold for each unit decrease in pH. At pH 7, the solubility of HA in water is about 30 mg/L, whereas at pH 4 it is about 30 g/L, or 30,000 mg/L (Dawes, 2003). This explains how frequent and/or continued exposure to sugar, and therefore lower pH, can affect the tooth structure. Oversaturation of the oral fluid causes deposits in the tooth structure. The loss of minerals from the enamel weakens the structure of the HA (Usha & Sathyanarayanan, 2009).

Featherstone proposed a way to think of these two related processes and the factors involved as “the caries balance,” a balance between demineralizing and pathological factors on one hand, and remineralizing/protective factors on the other (Featherstone, 2006).

The role of fluoride

Following ecological studies as early as the 1930s (National Institute of Dental and Craniofacial Research, 2018) that showed a lower prevalence of caries in regions with naturally occurring fluoride, numerous subsequent studies investigated the role of fluoride in the caries process. Fluoride is now understood to have a protective role through several mechanisms. If fluoride is present in the oral fluid, it can contribute to the remineralization of the tooth enamel. Tooth crystals are composed of calcium and phosphates. When the tooth remineralizes in the presence of fluoride it forms a crystal structure called fluoroapatite rather than the naturally occurring hydroxyapatite. Fluoroapatite has a slightly different chemical composition as the fluoride ion replaces the hydroxyl ion present in hydroxyapatite, resulting in calcium fluorophosphate ($\text{Ca}_5(\text{PO}_4)_3\text{F}$) instead of calcium hydroxide phosphate ($\text{Ca}_5(\text{PO}_4)_3\text{OH}$). The

importance of this is at least threefold. The increased availability of fluoride in the oral fluid promotes remineralization of the tooth, counteracting the detrimental effects of an unfavorably acidic environment. Fluoroapatite also has a lower critical pH, 4.5 compared to 5.5 of hydroxyapatite, making it more resistant to caries attack. Furthermore, fluoroapatite provides protection against *Streptococcus mutans* because it is mildly bacteriostatic and its surface energy makes it harder for plaque to adhere.

Fluoride protection can be delivered to the teeth in different dosages and through different means. Fluoridated water and toothpaste provide a low-level concentration of fluoride in the oral fluid, while fluoride varnish (or gels) provide a temporary but concentrated dose directly onto the surface of the tooth. The dynamics discussed thus far apply to the fluoride made available through fluoridated toothpaste and water, whereby increased concentrations of fluoride enters the structure of the enamel via saliva. Over-the-counter fluoridated toothpaste tend to range in the order of 1000–1500 parts per million (ppm) of fluoride. A higher concentration dentifrice (about 5,000 ppm) can be prescribed for higher risk.

Fluoridated water

Fluoridated water programs have been found to reduce the incidence of caries. Community water fluoridation could result in decreases of up to 35% in cavities in children, and a higher percentage of cavity-free children (Iheozor-Ejiofor et al., 2015). Fluoridation has been celebrated as one of the top 10 public health achievements of the 20th century (Center for Disease Control and Prevention (CDC), 1999). The CDC estimates that for every \$1 invested in water fluoridation, communities save \$38 in dental treatment costs. Though most of the studies were conducted before 1975, reductions in the incidence of caries in as much as two-thirds of them prompted the U.S. Public Health Service to urge the country in 1951 to fluoridate public drinking

water. About 75% of the U.S. population is served by public water supplying optimal fluoride levels to prevent tooth decay. Local water supplies are not all fluoridated in the U.S. (CDC, 2012).

Fluoridated toothpaste & toothbrushing

However, many have credited the introduction of fluoridated toothpaste in the 1950s for the subsequent reduction in caries prevalence in the last several decades of the 20th century (Bratthall, Hänsel-Petersson, & Sundberg, 1996). The consumption of sugar has not changed in recent decades, remaining at about 40kg per capita annually, but caries prevalence has declined worldwide. This is mostly attributed to the widespread adoption of toothbrushing with fluoride (van Loveren & Lingstöm, 2015).

Though different forms of toothpaste had been available for centuries, toothpaste as we know it emerged in the 1800s. The first commercially prepared toothpaste released by Colgate in 1873. In fact, most Americans did not brush their teeth daily until after World War II. In the early days of cariology, when the theory of non-specific biofilm was espoused, simply brushing off microorganisms was thought to reduce caries experience.

However, with the advanced understanding of the specific organisms involved, and the role of fluoride in protecting against their effect, new research programs emerged testing to incorporate fluoride into toothpaste. While several versions were developed between 1890 and 1940, it was not until after much development and testing that Proctor & Gamble launched its first clinically proven fluoride-containing toothpaste, Crest, in 1955, and in 1960 received endorsement from the ADA as an “effective anticavity dentifrice” (American Dental Association Council on Dental Therapeutics, 1960; Chace, 1964). A very impactful, though not altogether truthful, marketing campaign for Pepsodent, brainchild of Claude Hopkins, changed the oral

hygiene habits of a generation. Offering the reward of beauty and clean teeth, he lured more than half of the population to adopt a daily habit of toothbrushing. In the span of a decade, 65% of the population adopted usage of toothpaste, up from 7% (Duhigg, 2012), and thereafter made toothpaste a major source of revenue for companies like Unilever, Proctor & Gamble, and Colgate Palmolive.

Today, one of the main reasons to brush is to expose teeth to a protective dose of fluoride. Studies show that incorporating regular brushing helps prevent cavities on the order of 24% vs. a placebo (Marinho, Higgins, Logan, & Sheiham, 2003; Twetman, 2009). A Cochrane review confirmed that the relative caries-preventive effects of fluoridated toothpaste increased with higher concentrations of fluoride (Walsh et al., 2010). Current recommendations are to brush at least twice a day with fluoridated toothpaste; a smear or rice size for infants, and a pea size amount of toothpaste for toddlers, older children and adults (American Dental Association, 2014).

Though some have claimed that the effect of tooth cleaning is primarily due to the fluoride in the paste rather than the removal of biofilm, this issue is not entirely settled in the scientific literature (Sutcliffe, 1996 as cited by Fejerskov (2015) , and Davies, Davies, Ellwood, & Kay, 2003)). The mechanical effect of brushing still has an important contribution in the removal of plaque and microorganisms, as well as to eliminate food impaction and shorten the duration of sucrose exposure. A study of university students in Korea assessed the differences in bacteria present, dental plaque, and pH before and after toothbrushing. Though brushing along with gargling with Listerine mouthwash showed the greatest reduction in colony-forming units (CFU/ml), brushing alone also reduced the amount of bacteria in the oral cavity (Kwak et al., 2017). Creeth et al. (2009) also found that brushing time had an effect on the amount of plaque

removed: Brushing for 180 seconds removed 55% more plaque than brushing for 30 seconds. Other studies show a reduction in plaque between 30–50% from baseline, depending on type of brush and time (Rosema, Slot, van Palenstein Helderma, Wiggelinkhuizen, & Van der Weijden, 2016). Harris et al. (2004) found that at least in a population with limited oral hygiene, the mechanical effect of cleaning may add to the effect of fluoride.

After exposure to fluoride products, concentrations of fluoride in the whole saliva first increases rapidly and then decreases with the flow of saliva out of the mouth. Brushing before bedtime is thus particularly beneficial in that very low rates of saliva flow during sleep allow for longer exposure to higher concentrations of fluoride (Fejerskov et al., 2015).

Toothbrushing skills

There are several factors that influence the effectiveness of toothbrushing and long-term impacts on oral health. They include the age at which toothbrushing is initiated, toothbrushing skills related to a child's age, parentally supervised toothbrushing, frequency, and length of time brushing. Evidence suggests that children who do not start brushing within their first year have higher dmft values than those who start brushing within the first year (Sun, Bernabé, Liu, Gallagher, & Zheng, 2017).

Toothbrushing requires a certain amount of dexterity, so skill tends to improve with age. Dentists recommend that parents assist children with brushing their teeth until about the age of 8 (Christy, n.d.) or some say until the child can tie their own shoelaces. Young children learning to brush tend to play with the toothbrush and do little to clean their teeth, so mothers play an important role in helping them clean their teeth appropriately (Finlayson, Siefert, Ismail, & Sohn, 2007a). While twice-daily brushing with fluoride toothpaste is widely recommended and associated with better oral health outcomes for children than brushing once per day (Chestnutt,

Schäfer, Jacobson, & Stephen, 1998), studies also indicate not all parents do this. A Chinese study found that only one in seven 5-year-old children received regular toothbrushing twice a day (Sun et al., 2017). Castilho et al. (2013) found that though 47% of mothers reported their children brushed their teeth three times a day, only a third assisted with brushing, while the rest only supervised. Measuring toothbrushing is often plagued by a social desirability bias of what “should be.” Castilho found an incompatibility between caries index and reported brushing frequency. Reports from qualitative studies indicate that parents’ self-efficacy and ability to manage their children’s challenging behavior related to toothbrushing will closely determine a child’s toothbrushing habits (Finlayson et al., 2007a; Marshman et al., 2016; Trubey, Moore, & Chestnutt, 2015). Many parents for whom this is a challenge often adopt a role of simply reminding their children to brush or watching them brush, consequently reducing the duration, frequency and efficacy of toothbrushing in children (Marshman et al., 2016). Less supporting parenting styles and lower rates of self-efficacy in managing child behavior is more common in lower socioeconomic groups.

Sugar vs. Fluoride

Several *in situ* studies have evaluated the relationship between sugar exposure and fluoride from toothpaste on caries. Studies find that the relative balance of these two is what will determine demineralization. Duggal et al. and Ccahuana-Vasquez et al. (cited in dos Santos Noronha, Andrade Romão, Aparecido Cury, & Pereira Machado Tabchoury, 2016) found that if the intake of sugar was below 7–8 times per day, then fluoride from 1,100 µg F/g toothpaste was effective to control demineralization of the enamel. Cury et al. (2010) found that toothpaste with 1,100 µg F/g was more effective in slowing down caries progression than one that had half this concentration when sugar exposure was above twice daily. Dos Santos Noronha et al. (dos

Santos Noronha et al., 2016) tested the effect of fluoride concentration on reduction of demineralization of enamel slabs subjected to two levels of sugar exposure (8x and 16x per day) and exposed to three levels of fluoride solutions (0, 275 and 1.250 µg F/mL) to represent mouth salivary dilution of fluoride when 1,100 and 5,000 µg/g toothpaste are used. They found higher level of fluoride significantly reduced the loss of enamel surface hardness compared with the lower concentration of fluoride irrespective of the levels of cariogenic sugar challenge. This suggests that fluoride concentrations could be used to compensate for the greater caries risk for those with higher sugar consumption (dos Santos Noronha et al., 2016). Skafida and Chambers (Skafida & Chambers, 2017) found that toothbrushing can only partly attenuate the association between snacking and longer-term sugar consumption on dental-decay outcomes in young children. They found that the children who were most likely to have decay at age five were those who consistently eat sugary foods at both ages two and five, and also brushed their teeth the least. Other reports find that fluoride is associated with about 25% lower caries experience when sugar intakes are constant between 10–15% of energy intake in 12-year-old children (Marthaler, 2004 as cited by Sheiham & James, 2014).

Fluoride varnish

Topical fluoride has a much higher concentration of fluoride than toothpaste, ranging from 22,600 to 45,000 ppm. A topical varnish increases the concentration of fluoride in the outer surface of teeth, enhancing fluoride uptake in the early stages of demineralization. Made of a type of sticky resin, varnish hardens on the tooth as soon as it contacts saliva, providing a longer period of exposure to the tooth enamel (1–7 days). High concentrations of fluoride remain for a considerable time after application. Topically applied fluoride from the varnish diffuses into the plaque where calcium fluoride forms, and subsequently acts as a slow releaser of fluoride for

some time after exposure (Fejerskov et al., 2015). A Cochrane Database meta-analysis reports a 43% prevented fraction of DMFS in permanent teeth and 37% in primary teeth (Marinho, Higgins, Logan, & Sheiham, 2002).

The amount of fluoride deposited in the tooth surface is considerably greater in demineralized versus sound tooth surfaces (Sköld-Larsson, Mod er, & Twetman, 2000; ten Cate & Featherstone, 1991). Thus, the benefits of fluoride varnish are greatest for individuals at moderate risk or high risk for demineralization or tooth decay (ADA Council on Scientific Affairs, 2006; Marinho, Higgins, Sheiham, & Logan, 2004b, 2004a).

The evidence on the preventive effect of topical fluorides on dental caries has been extensively reported (Marinho, 2008, 2009; Marinho et al., 2002; Marinho, Worthington, Walsh, & Clarkson, 2013; Robert Weyant et al., 2013), pointing to a clear benefit of fluoride varnish application at least twice per year for caries prevention in children and adults, but studies on application frequency indicate results can vary. Weintraub et al. (2006) conducted a randomized control trial of the efficacy of fluoride varnish on children 6–44 months of age followed for two years, receiving counseling and either no varnish, or once or twice a year. At the time the consensus on the effect of fluoride varnish appeared to be stronger with regards to permanent teeth than primary teeth. Weintraub et al. found a significant reduction in the percentage of children with any caries incidence when comparing children with two or four applications with the control group, and the percentage decreased with increasing number of fluoride varnish applications, signaling a significant inverse dose response effect. Braun et al. (2017) found that caries experience was significantly improved in children who received at least four fluoride varnish applications before the age of three (in this study they were treated by a medical provider).

Of particular interest to this study is that fluoride varnish can also be used therapeutically to reverse demineralization in early carious lesions. When applied with higher frequency, fluoride varnish helps remineralize white spot lesions and render them inactive. A recent meta-analysis found that fluoride varnish is an effective approach for arresting the progression of enamel carious lesions in primary and permanent teeth. However, there are different protocols for the treatment of white spot lesions based on diverse application times and intervals; for example, weekly applications versus every two months. In this review, both were found to be effective. A study by Autio-Gold and Courts (2001) in preschoolers found that 81.2% of active enamel lesions were inactive after nine months in the group that received two fluoride varnishes with a four-month interval. This compared to only 37.8% of active lesions in the control group ($P < .0001$). Gao et al. (2016) conducted a systematic review of 17 randomized control trials to study the remineralizing effect of fluoride on enamel lesions. Through a meta-analysis they concluded that 64–66% of carious lesions were remineralized depending on the type of fluoride used. Though most fluoride varnish is formulated with sodium fluoride as the active component, silver diamine fluoride (SDF), which has been used extensively in Europe for many years, was recently approved for use in the U.S. market, and AAPD issued guidelines for its use in 2017 (AAPD, 2017). SDF can heal carious lesions quicker than varnish, but has a drawback of staining the tooth where the lesions are due to the silver content. This solution is particularly useful for lesions on primary teeth, as it is inexpensive and requires only a short time for application. Both of these materials are important clinical tools in the dentist's arsenal for secondary prevention of caries.

Acquisition and transmission

Unbeknownst to many public health professionals, caries is an infectious and transmissible disease. It is commonly acquired through vertical transmission of *mutans streptococci* from

mothers (or active caregiver) to their infants. (Dye et al., 2011; Y. Li & Caufield, 1995).

Compelling evidence from studies using chromosomal DNA patterns to link the bacteria of the mother to that found in children helped substantiate this vertical transmission (Lapirattanakul et al., 2008). Caries usually follows within 6–24 months of the appearance of *S. mutans* in the mouth (Balakrishnan et al., 2000). Evidence of transmission associated with fathers is conflicting: Pannu et al. (2014) and Emanuelsson et al. (1998) found it to be minimal or non-existent, whereas Kozai et al. (1999) and Hameş-Kocabaş et al. (2008) found evidence of transmission, though less frequent than from mothers. There is also evidence of horizontal transmission between siblings or peers (Mattos-Graner, Li, Caufield, Duncan, & Smith, 2001).

Age of acquisition

The age at which a child is initially inoculated with cariogenic bacteria has emerged as an important risk factor for early childhood caries and future caries experience and severity. Earlier studies suggested a specific “window of infectivity” ranging from 19 to 31 months old (median 26) after the eruption of primary teeth, during which infants with tooth surfaces to invade were believed to have an increased susceptibility to infection. Caufield et al. (1993) found that 75% of a group of high-risk children had acquired the organisms by 31 months. However, evidence from more recent studies has refuted this window of infectivity, with indication that MS can colonize the mouths of infants even before teeth erupt (Berkowitz, 2006). This would be consistent with case reports at UCLA’s Infant Oral Health clinic, where there have been cases of infants whose teeth erupt with lesions. Wan et al. (2001) detected MS in approximately 30% of babies as young as three months of age. The factors associated with pre-eruptive MS colonization were:

- early weaning
- sleeping next to mother

- breast-feeding
- consumption of sugar 2–3 times a day

However, the age of infection is still considered a risk factor for future caries experience. Köhler & Andréen (2012) followed up with a group of children 19 years after their mothers participated in an early maternal caries intervention program aimed at reducing transmission. They found that early colonized children had higher levels of bacteria and caries experience than later colonized children (Köhler & Andréen, 2012). In another study they found that close to 90% of children colonized at two years of age had experienced caries by age four compared with only 25% of those colonized later or noncolonized by 4-year-olds. They also had 10 times higher dfs at age four than those that did not carry MS (Köhler, Andréen, & Jonsson, 1988).

Early childhood caries is the greatest risk factor for caries in permanent teeth (Fisher-Owens, 2014; Li & Wang, 2002). Children exposed to cariogenic bacteria and infected at a younger age tend to develop much more aggressive caries and at an earlier age (Alaluusua & Renkonen, 1983; Köhler et al., 1988). Close to 90% of the early carriers developed caries and had 10 times higher dfs at four years of age than children who did not carry *Mutans streptococci* at this age.

Maternal oral health

The likelihood of transmission from mother to child is related to the burden of bacteria that the mother has, usually associated with the maternal level of active decay. Higher levels of *S. mutans* is associated with higher level of cavities. Successful infant colonization of maternally transmitted MS organisms is, in part, related to the magnitude of the exposure (Berkowitz, Turner, & Green, 1981). Berkowitz et al. found that mothers harboring greater than 10^5 colony forming units (CFUs) of MS per ml of saliva were nine times more likely to infect their infant

than if they harbored only 10^3 CFU/mL (Berkowitz et al., 1981). Berkowitz contributed what is known as the Berkowitz SM level categorization, which includes the following: level 0: $< 10^4$ CFU/mL; level 1: 10^4 – 10^5 CFU/mL; level 2: 10^5 – 10^6 CFU/mL; level 3: $>10^6$ CFU/mL (Berkowitz et al., 1981).

Studies in Japanese mother/child dyads found that 70% of the child's salivary *S. mutans* matched those of the mother, and was even higher (90%) for girls (Lapirattanakul et al., 2008). These data, and those from many other studies (Berkowitz, 2003, 2006; Berkowitz, Jordan, & White, 1975; Berkowitz, Turner, & Green, 1980; Berkowitz et al., 1981; Chaffee, Gansky, Weintraub, Featherstone, & Ramos-Gomez, 2014; Finlayson et al., 2017; Law, Seow, & Townsend, 2007; Pannu et al., 2014) indicate that mothers with dense salivary reservoirs of *S. mutans* are at high risk of infecting their infants early in life, and of their children to develop early childhood caries. Other factors associated with infants being infected are mothers with poor oral hygiene, more periodontal disease, lower socioeconomic status, and frequent snacking (Wan, Seow, Purdie, et al., 2001).

Several intervention studies have demonstrated that measures aimed at reducing the bacterial load in highly infected mothers can delay and even inhibit transmission of these cariogenic bacterial to their infants. Köhler and colleagues found that only 11% of mothers whose bacterial loads were suppressed by treatment of active caries and topical chlorhexidine gels infected their babies by 23 months of age, compared to 45% of the control group whose MS levels were not suppressed (Köhler & Andréen, 2012; Köhler et al., 1988).

In summary, the oral health of the mother is a substantial risk factor for how quickly a child can be colonized with cariogenic bacteria. This is important because the age of infection is a

strong predictor of early childhood caries and the level of caries experience later in life.

Reducing the bacterial load of the mother can improve the chances the child will not be infected.

Stages and progression of disease

In this dissertation, I will narrow my focus on three types of general dental lesions that develop as a result of caries: incipient or white spot lesions, enamel cavities, and dentin cavities. Initial or incipient lesions are white chalky lesions on the enamel. They appear chalky because they have demineralized, and therefore do not reflect light in the same way that intact enamel does. This is the first clinical indication of the caries process in a patient. These lesions, however, can heal by remineralizing under a proactive course of increased fluoride exposure. Though a mark may remain, the lesion becomes inactive and hardens with the fluoride treatment.

The ICDAS (International Caries Detection and Assessment System) is a system that allows a researcher or clinician to track the severity and incidence of caries by tooth. Tracking activity of white spot lesions is an important aspect of early intervention and control of caries. As demineralization of the enamel progresses, greater parts of the tooth are affected. First comes the enamel, resulting in enamel cavities. If the process continues, the dentin becomes affected, and a deeper cavity results.

Risk & protective factors – oral health and personal health behaviors

In addition to the biological transmission of caries, there is also an important “social contagion” aspect to the disease. Studies suggest an association between children’s habits that are closely aligned with those of their mothers including their food habits (meals, snacking, and sugar consumption) and oral hygiene practices (Adair et al., 2004; Mattila et al., 2000). A study by Gonçalves et al. (2016) looked at the intergenerational association between dental caries, dental

care, oral hygiene, and dietary habits. Children of parents who did not have regular visits to the dentist had higher caries experience, as had those of parents who had sugar consumption between meals. Parents' own oral hygiene habits were also found to be related to dental caries in their children (Wigen, 2010 and Costa, 2008 as cited by Gonçalves et al., 2016).

Several aspects related to parents and parenting style have also been linked to oral health of their children. Feelings of self-esteem and relationship with parents have been associated with a child's oral health status. A high degree of parent stress associated with punitive, aggressive, and neglectful behavior towards children may unleash psychological reactions leading to poor oral health outcomes (Abreu et al., 2015). A parent's sense of self-efficacy and locus of control might also be passed on to their children. Children's habits have been found to be related to the parents' own self-care and eating habits, as well as the parents' knowledge and attitudes towards caries. Parents' self-efficacy and ability to control their child's toothbrushing and sugar consumption have been found to be a significant predictor of whether or not favorable habits were reported (Adair et al., 2004; Castilho et al., 2013). Furthermore, since children's food preferences are formed at an early age, it is important to intervene early while these preferences are being formed (Skinner, 2002 as cited by Arvidsson et al., 2016).

Life-course studies provide a multilevel model that identifies different factors involved in the development of chronic oral diseases. This model is of value in assessing how those factors may cluster.

Dental Care Processes of Care

The current model of dental care delivery in the US is predominantly in the private practices setting (American Dental Association (ADA), 2018; Institute of Medicine & Harris, 2009; Mertz

& Finocchio, 2010) paid through a fee-for-service model. As can be appreciated with respect to the disparities discussed earlier, this model has been effective and efficient in providing dental care to only about two-thirds of individuals in the U.S.: those that are generally healthier, have resources and live independently, have access financially and geographically to professional services, and exhibit good care-seeking behavior. For the remaining third of our population, some argue that this model of oral health care can be a major impediment to addressing their oral health needs (O'Neil & Ngai, 2011). There have been calls to take advantage of the current environment of healthcare reform as an opportunity to consider practices outside the prevailing model; expanding the traditional practice model is not likely to be any more effective than it has been in meeting the pressing needs of the most vulnerable populations.

Risk and Disease Management

The 2001 National Institutes of Health Consensus Statement officially recognized the paradigm shift in caries management toward the more conservative treatment of caries (Kakudate et al., 2015; NIH, 2001). As a result, current standards of care recommend that treatment planning for caries include a risk assessment for each patient so that an individualized prevention and treatment program can be developed (Hurlbutt & Young, 2014; Kakudate et al., 2015; Young & Featherstone, 2013). These guidelines reflect a new paradigm in dentistry that aligns with decades of developments in the study of cariology, the behavioral connections to caries and improved understanding of the epidemiology of caries.

Furthermore, caries risk assessment guidelines and tools have been developed by many professional dental associations including the California Dental Association (CDA) (initially in 2003 and updated in 2007); ADA created two forms in 2006, published its adult and child

version in 2009 and updated them in 2011; and AAPD published its guidelines and forms in 2006 followed by several revisions in 2010, 2011, 2013 (Hurlbutt & Young, 2014) and 2014. In 2009, the ADA Council on Scientific Affairs released a position statement endorsing the use of caries risk assessment as a standard of care and in 2014 the ADA added three CDT codes, D0601, D0602, and D0603 (low, moderate, and high risk), for caries risk assessment (Dental Quality Alliance, 2017; Dukes, 2014; Texas Medicaid & Healthcare Partnership, 2014).

The AAPD recognizes a “dental home” for children should be similar to a medical home — it should provide services that are comprehensive, continuously accessible, family centered, coordinated, compassionate, and culturally effective care for children (AAPD, 2015). Comprehensive oral health care includes acute care and preventive services following AAPD periodicity schedules ((AAPD), 2015b). This would also entail a preventive dental health program that is individually tailored based on a caries-risk assessment ((AAPD), 2015a). Dentists are also to provide anticipatory guidance regarding growth and development and provide information about proper care of the child’s teeth to the parents.

In the last two decades experts from dentistry, public health, behavioral modification, and quality improvement dedicated much attention toward developing training programs, clinical tools, and processes to help accelerate the translation of empirical evidence about risk-based care into clinical practice. The AAPD, ADA, and AAP have each developed their own versions of caries risk assessment forms. Also following two consensus conferences in California, Featherstone et al. developed the Caries Management by Risk Assessment (CAMBRA) form to guide dentists in assessing risk and disease status (Featherstone, 2003; Young & Featherstone, 2013). First piloted in 2003, the forms and procedures have undergone substantial testing and modifications over the last 15 years.

All of these forms include risk or biological predisposing factors, protective factors, and disease indicators from the clinical examination. Though different number and details of risk factors are included, similar domains are included. AAP's version for physicians classifies a patient as low or high risk, whereas AAPD's and CAMBRA risk assessments classify a patient as low, moderate or high risk. In addition to risk assessment forms, CAMBRA has detailed clinical protocols to accompany them (Ramos-Gomez et al., 2010). A risk assessment is the first step of a process designed to manage caries risk and disease, particularly in early childhood, but can also be applied throughout the life course. Ramos-Gomez and Ng (2000) outline a six-step protocol for an infant oral care visit (See Table 1) that details how to incorporate risk assessment, patient/parent counseling and anticipatory guidance, dental cleaning and examination, and fluoride varnish application.

The caries risk assessment allows the provider to capture information about various risk and protective factors relating to the child's diet and snacking habits, family toothbrushing and use of fluoridated toothpaste, oral health history, bottle feeding, caries in parent and siblings, etc. This can all be included as part of obtaining the medical and dental history. Often this part of the risk assessment can be obtained by a dental assistant.

Children six months to three years are often too small for a dental chair and can feel intimidated by an unfamiliar environment. The knee-to-knee position starts with the child on the parent's lap, facing the parent. The dentist then faces the parent so that their knees meet and the

Table 1. Six-Step Protocol for Infant Well Baby Oral Care Exam (IOCE)

Six-step protocol for an infant oral care exam:

1. Caries risk assessment
 2. Proper positioning of the child (knee to knee exam)
 3. Age appropriate tooth brushing prophylaxis
 4. Clinical examination of the child's oral cavity and dentition
 5. Fluoride varnish treatment
 6. Anticipatory guidance, counseling and self-management goals
-

child can lean back on the dentist's lap. This allows the dentist good access to the child's mouth, while at the same time, the child can see the parent. The parent assists with managing the child's movement by holding the child's hands and using arms/elbows to hold child's legs against her waist while the dentist looks in the mouth. Children over three can generally sit forward on their caregiver's lap or sit alone in a chair.

Showing parents how to brush a child's teeth, and how much toothpaste to use is an important step. Studies have found that parents' sense of self-efficacy in brushing their child's teeth is a predictor of whether children will have their teeth brushed. The clinical examination will provide the final piece of information to determine a child's level of risk, noting plaque accumulation, presence of lesions or history of restorations will initially put a child at high risk, whether it is restored or untreated. An important part of the clinical examination for risk and disease management is noting any initial white spot lesions and documenting them so they can be monitored and treated.

Children at moderate or high risk should receive a full mouth topical fluoride varnish, and scheduled to receive reapplications within intervals based on their risk level; for example, every six months if moderate risk, or three if high risk. If the child has active white spot lesions, a high-risk schedule is recommended to treat the lesions with frequent topical fluoride applications.

The goal of the last part of the visit is to reach a mutually agreed upon set of self-management goals appropriate for the family. The dentist at this point would relay the results of the risk assessment and clinical exam and explain to the parent the causes of the caries process. Drawing on motivational interviewing skills, the goal is to activate the parent towards change and adoption of protective behaviors that are specific to their child's risk and disease, their family situation, and ability. The parent is asked to choose two goals from a Self-Management

Goals sheet(See Ramos-Gomez, 2014 for an example) that they feel they can commit to and express their level of confidence in accomplishing the goals. Finally, the patient is scheduled to return based on their level of risk or need for restorative treatment.

Motivational interviewing and behavior change

Motivational interviewing (MI) is a patient-centered counseling technique that emerged out of the addiction field in the 1980s. It is a non-confrontational approach found to be effective in empowering individuals towards behavior change; it has also been found to be effective in reducing caries, especially in high-risk children. MI is in direct contrast to the traditional style of patient communication most dental professionals were taught and practice, often referred to as “provider-centered” health education. Evidence suggests traditional information and advice giving has serious limitations, resulting in short-term knowledge gain but minimal impact on behaviors or actions (Weinstein, 2011). Based on best practices in counseling/psychotherapy, relational and technical components are central to the MI technique; the relational drives the person-centered aspect, while the technical focuses attention on the patient’s change language. The goal of MI to strengthen the idea of change from the patient's perspective (Burke, Arkowitz, & Menchola, 2003, in (Martins & McNeil, 2009) is advanced using four basic principles to enhance motivation:

- 1) establishing empathy and a mutually trusting relationship;
- 2) developing of discrepancy between current and needed behavior without resorting to advice-giving and respecting the independence of the patient;
- 3) asking questions and listening to help trigger a patient’s awareness of the problem and need to take action; and
- 4) supporting self-efficacy by giving the patient choices and exploring courses of action tailored to their needs and motivations (Martins & McNeil, 2009).

This technique allows the provider to assess the patient's readiness to change or take action, and explore the reasons driving resistance in order to help them get to supportive behaviors.

There have been numerous studies on the effectiveness of MI in achieving a range of behavior changes and health outcomes including oral health, diet and fitness, screen time, smoking cessation, etc. A systematic review and meta-analysis (Borrelli, Tooley, & Scott-Sheldon, 2015) found parent-involved MI associated with significant improvements in health behaviors and biomedical outcomes. There was a significant effect of MI on oral health behaviors (toothbrushing, visiting dentist) compared to control groups in four different studies. Weinstein and colleagues reported on an MI study to control caries in a high-risk East Indian population, and found the MI group showing half the caries rate as the standard education treatment (Weinstein, Harrison, & Benton, 2004). While the technique holds much promise to help dentists work with patient to move them towards good oral health-related behaviors, it is also a skill that must be practiced to be mastered.

Effectiveness of caries risk and disease management in practice

Pienihäkkinen and Jokela have reported on a series of studies conducted in Finland to evaluate outcomes in young children following risk-based management of dental caries in comparison with routine prevention in a dental setting. In this protocol, instead of using a caries risk assessment, the assessment of risk was based on a plaque test for *mutans streptococci* (MS). In the first study, 2-year-old children (born in 1987 and '88) were followed for three years. At five years of age, fewer children in the risk-based group had caries and/or fillings than those in the routine prevention group. Furthermore, risk-level differences were significant. In the routine prevention group, the odds of developing cavities and/or fillings at the age of five years (d3mfs)

were 2.8-fold for children at intermediate risk in comparison with the risk-based prevention group, and 10.3-fold within the high-risk category (Pienihäkkinen & Jokela, 2002).

An economic evaluation of the same study found that in the risk-based group, dental assistants spent significantly longer time on preventive services, while the time spent on restorative treatment was significantly shorter than in the routine prevention group. Also, the costs of restorative treatment (and thus total costs) were significantly higher in the routine than in the risk-based prevention group. They concluded that a risk-based prevention program can be effective in reducing both dental caries and the costs, provided the dental assistants provide the preventive aspects of the program. The investment in risk-based prevention at this early age reduced the need for restorative treatment and need for a dentist/dental assistant team. They also concluded that for Finnish preschool children, there is no need to re-evaluate low-risk children every year (Jokela & Pienihäkkinen, 2003).

A follow-up study, seven years after the end of the targeted program, examined the clinical and economic findings when the same groups of children. At age 12, DMF (decayed, missing, filled) in both study groups was still related to the risk category determined 10 years earlier. The total number of visits (preventive and restorative) was lower in the risk-based than in the routine prevention group. The estimated running costs were lower in the risk-based group than in the routine prevention group in all risk categories. This project was conducted at a time when the relative roles and division of labor between hygienists and dental assistants were being contested in Finland. The program was more cost effective when dental assistants were used instead of hygienists for the prevention work with parents (Pienihäkkinen et al., 2005). Overall, the findings indicate that the early risk-based prevention can be correctly targeted, clinically effective, and economically profitable with long-term payoffs.

Another set of studies conducted by the group that developed the CAMBRA protocol has also shown the effectiveness of using combination therapies for patients identified at high risk through risk-based management of caries (Featherstone & Chaffee, 2018).

Ng et al. published the results of a quality improvement learning collaborative that implemented a risk-based disease management protocol for ECC in two hospital-based dental clinics that care for children. Results from the pilot showed that significantly fewer ECC patients in the risk-based disease management program experienced new cavitations, pain or had to be referred for treatment in the operating room compared to the historical control groups. At one site, only 26% developed new cavitations compared to 75% in the control, at the other 41% compared to 71% (Ng et al., 2012).

This team also followed up with parents to inquire about their experience with the disease management approach since it requires parental engagement and willingness to alter diet, oral hygiene and return for more frequent follow-up visits. Most parents reported the approach was helpful for their children and almost all appreciated being given reasons why their children may have developed ECC. Reports by parents included feeling that the approach was less judgmental and felt less blamed for their child's condition; they appreciated the collaborative relationship with the providers and felt they were given a voice in the dental care of their child (Ng et al., 2012).

Traditional one-size-fits-all approach to caries

How different is what has traditionally been practiced by dentists from the risk-based approach to caries? There are several important differences. The main difference is that dentists have traditionally applied a one-size-fits-all approach when it comes to prevention. Although the 6-month recall interval has little empirical evidence to support it, it has continued to be a hallmark

of the dental profession for the last century (Patel, Curtis Bay, & Glick DMD, 2010), yet has been questioned and studied in the last several decades. Sheiham suggested in 1977 that the interval could be longer than six months without disadvantage because in adults caries takes about two years to progress. Subsequent reports have extended that time up to six years. Patel (2010) conducted a systematic review of recall intervals and could not support the concept of using a one-recall-interval-fits-all protocol, and instead suggested that an interval based on a patient's risk would be beneficial.

It is to be expected that when a one-size-fits-all approach is applied to a heterogeneous population with a range of needs, unless it proves to be an overly generous offering, those individuals with highest needs may not receive what they require, and perhaps those at the opposite end, with the lowest level of need, will receive more than they require. Linking the clinical needs of the patient to the scheduling of visits for preventive services more frequently than six months is rare, and not supported by most current reimbursement programs, private or public. But from a conceptual standpoint, if low-risk patients were to be recalled every year or two, greater attention and preference might be given to individuals with higher need for preventive and restorative care.

A second difference is how the dentists respond to incipient or white spot lesions. Dentists are not reimbursed for chemically treating these lesions to heal them. Hence, the traditional approach is to "watch" them. Some of these lesions will arrest on their own, and nothing needs to be done. Most will progress and cavitate, at which point the dentist can "drill, fill and bill" for it. Since the enamel is thinner in younger children's teeth, a lesion can happen within months, as opposed to what might be years in permanent teeth. As discussed previously, quality dental care would enhance conditions for remineralization of white spot lesions to avoid advancement to

cavitated lesions. Aside from significantly easing the cost and physical discomfort, this approach also has clinical benefits. Most secondary lesions occur where there have been previous lesions, and up to 71% of all restorations are performed on previously restored teeth, with secondary lesions as a major cause (Fontana, 2000 as cited by Dias et al., 2017). Once the tooth is cut for a filling, following restorations will need to cut even more, and with each restoration successively larger holes drilled, eventually resulting in complete loss of the tooth structure. A new paradigm in minimally invasive dentistry supports protecting the tooth structure as much as possible. Remineralization therapy is an effective way of doing this.

The third difference relates to the dentists' approach to helping a patient reduce their risk for caries once identified. Typical dental education has included provision of educational materials instructing patients or caregivers to brush twice a day, use fluoridated toothpaste and avoid sugars. However, ample evidence from health educators and cognitive scientists explain why information alone is not sufficient to change habits. Use of counseling and motivational skills such as motivational interviewing can help improve the likelihood of behavior change. These are not skills historically part of dental program curricula, and thus not part of the educational toolset of most dentists. Furthermore, when these discussions are tailored to the unique needs of the patient, there is a demonstration of concern and partnering with the patient/caregiver to address the situation. This is a more empowering position for patients (versus being told what to do) and helps activate them in caring for their own oral health.

All three of these differences work recursively and in concert. Not only does risk-based scheduling bring a patient in more often to receive topical fluoride, it increases the chances for counseling and motivational conversations, thereby reinforcing the oral health messages and

understanding of the disease. This also can have an impact on the patient-provider relationship, and on the level of patient trust, which is especially vulnerable among higher-risk patients.

The conflicting goals of the present-day dental-care business model

One of the most significant barriers to risk-based care is that as a whole, most Western health systems are more oriented towards treatment of symptoms rather than disease prevention and management. Historically, dentistry is a good example of this orientation. Risk-based disease management care offers a clear and compelling model that is better for both patient and practitioner. Why then have we not seen adoption of risk-based practices, especially since this approach has been around since the 1970s and some might even say the turn of the last century? Dentistry is not alone in this conundrum; the common experience in health care (and in all complex systems) is that better methods and practices are generally not difficult to discover, but getting our systems to align with supporting those improved processes often lands somewhere between extremely difficult and impossible.

The frustrating reality is that disease management rather than restorative care is the central value proposition. In dentistry, the dominant operational and support structures are focused on surgical care, and those structures block dentist from embracing a risk-based preventive approach because the “fee for services” model incentivizes a high volume of services (procedures). This is primarily an economic construct, and while many researchers acknowledge this, few address it. Compton (2015) and (Christensen, 2001) are notable exceptions, directly facing the business and financial aspects that must be supported if a preventive care model can replace the surgical model.

For example, several procedural aspects of the risk-based protocol are not reimbursed by private insurance or Medicaid. This is because the current financial model is compensation for a

service, not compensation for good health outcomes. A cavitated tooth requires a restoration, but restorations increase the likelihood of future restoration; a better health outcome would be to prevent the cavitation. This means a radical departure from how dentists practice currently, and a radical change in how insurance companies provide compensation. Right now, risk assessment and counseling are time-consuming and there is not a billing model, thus it becomes a pure cost center; there is no billing coverage. Most insurance plans only pay for up to two visits a year; but if a dentist is working with a high-risk patient, they may need to come in 4–6 times a year, and those additional visits and treatments will not be covered by their insurance. In California, a Fluoride varnish is allowed only twice a year under the Denti-Cal program (Medicaid); a pediatrician, however, can apply it three times a year with reimbursement coverage.

All of this undermines the goal of good health outcomes. Compton (2015) gives a concise example of the conflict:

An adult prophylaxis produces net revenue of \$91.40 per hour after covering the care provider's salary; a three-surface amalgam yields \$143.80 in net revenue; a three-surface composite produces \$219.80 in net revenue; and a crown yields \$374.80 per hour. The design of benefit programs provides significantly greater financial incentives for more invasive surgical procedures, and some of the preventive services provided under the ECC [early childhood caries] protocol are not even covered.

In other words, dentists are put in the morally and ethically awkward position of being financially incentivized to provide a health service that eventuates for their patients to worse health outcomes.

Dental billing procedures are another challenging area. Historically dentistry uses procedure codes rather than diagnostic codes; without diagnostic codes, there is no systematic way to

objectively monitor health conditions over time. Only recently through much-concerted effort of risk-based care advocates were new CDT codes added to code different levels of risk in practice.

Compton (2015) notes that preventive service delivery is a disruptive model because disruption implies an innovation that simplifies and decreases cost; and that disruption is rarely successful without a significant change in the business model of the industry. From the patient perspective, risk-based care increases oral health and impacts the overall health picture; it is a clear and desirable good. From a dental perspective, the health impact is much more positive than traditional surgical treatments, it moves people to improved health conditions, and overall takes less time. The missing piece is how to do this in a way where compensation does not suffer.

Dentists are no different from anyone else in the need to sustain a profitable business. This forces them to do what they will be compensated to do; pro bono work aside, they don't do what they aren't compensated to do. Disease management has not been adopted by dentistry primarily because there isn't a compensation model for it. This is exactly where modeling can assist. Creating a virtual service delivery environment, we can determine what kind of health impact a risk-based approach has on a community, what kind of operational structure is needed to support it, and conceptualize ways in which compensation for dental services make it financially viable.

Patient and population approaches

This shift to a risk-based approach to oral health applies not only at the clinical and individual levels, but also provides a helpful model for organizing population and public health services aimed at helping vulnerable populations. Crall proposes a risk-based approach to population oral health and dental care that provides tiered levels of care based on risk and lesion status. Figure 3 lists what resources and activities/services are needed for each level of risk and disease. By

Population-Based Approach for Dental / Oral Health Care Delivery

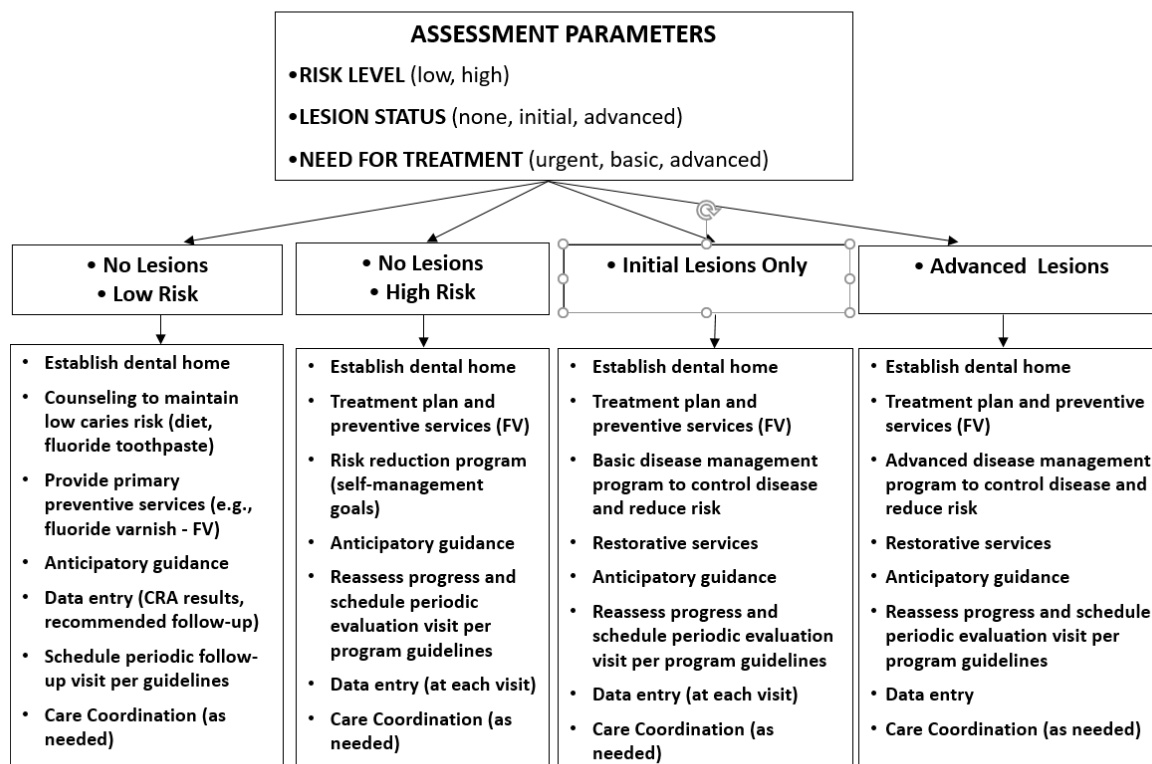

Figure 3. Population-Based Approach for Dental/Oral Health Delivery (Adapted from Crall, 2005a)

parsing out groups in the population it is possible to consider who else can participate in the services listed in a collaborative way (James J. Crall, 2005). While this approach was initially presented toward engaging primary care physicians in oral health services, many others can participate in the oral health team in support of children. This would include preschool or Head Start centers and advocates, WIC counselors, physicians and managed care organizations; as we move up in level of risk and disease, more specialized dental providers are required.

There is emerging evidence that a tiered approach to care based on a patient's risk can allow for efficient use of personnel with a reduction in both cost and caries in preschool children (Jokela & Pienihäkkinen, 2003; Pienihäkkinen et al., 2005). Risk-based care is also practical given limited availability of pediatric dental providers in most communities (Jokela &

Pienihäkkinen, 2003; Pienihäkkinen et al., 2005). There is emerging evidence that a tiered approach to care based on a patient's risk can allow for efficient use of personnel with a reduction in both cost and caries in preschool children (Jokela & Pienihäkkinen, 2003; Pienihäkkinen et al., 2005). Risk-based care is also practical given limited availability of pediatric dental providers in most communities (Jokela & Pienihäkkinen, 2003; Pienihäkkinen et al., 2005).

Dental Care Delivery System

Dental workforce

In 2017 there were 198,517 practicing dentists in the United States. This translates to 61 dentists per 100,000 population (ADA HPI, 2017), but dentists tend to practice in more populated areas and with higher per capita income, creating dental shortage areas in some regions of the country. Rural areas, particularly in the Midwest or Southern regions of the U.S., have fewer dentists per 100,000 population (Wall & Jackson Brown, 2007). HRSA determined in 2011 that we would need an estimated 9,333 new dentists to cover the 4,639 Health Professional Shortage Areas with 33.3 million underserved individuals.

Though the profession has historically been male-dominated, the number of female dentists graduating from dental schools is increasing. In 2001 the profession was 84% male to 16% female; in 2017 the ratio was 69% to 31%. This also means a greater percentage of younger dentists are women; only 31% of male dentists are below 44, compared to 56% of female dentists (ADA HPI, 2017).

Dentists are predominantly white (73.6%). Asians are overrepresented in relation to the proportion in the population (15.8%), and both black and Hispanic dentists are underrepresented

(4.3% and 5.3%, respectively). These proportions can vary widely by state; in Florida 20.5% of dentists are of Hispanic origin in a 25% Hispanic population, whereas in California only 8.2% of dentists are of Hispanic origin and almost 39% of the population is of Hispanic origin. In contrast, about 18% of dentists in California are of Asian origin, and that population is 15%. The District of Columbia, where about 48% of the population is black, has the highest representation of black dentists, 31.8% (ADA HPI, 2017; U.S. Census Bureau, 2017b). Representation of underrepresented minorities among dental students has slowly been increasing (Diringer, Phipps, & Carsel, 2013).

Dentistry has often been referred to as a “cottage industry” because most dentists are in private practice and either own or share ownership of their practice. Solo practitioners account for about 67% of dentists, and those in ownership positions about 91% of all dentists. With mounting pressure from insurance plans and public programs to lower costs and increase efficiency, the landscape of dentistry is starting to change, with increasing numbers of larger group practices, including large companies (Dental Support Organizations, DSO) with multisite operations (Guay, Wall, Petersen, & Lazar, 2012). Younger dentists are more likely to be employed in a large group practice until they can establish their own operations.

Dental students emerge with one of the highest debt loads of any profession. The American Dental Education Association (ADEA) reports that the average debt per graduating dental student is \$287,331, with 10% having debts of over \$400,000. Debt load, which has increased fourfold since the 1990s, has been reported as the single greatest factors that influence whether dental students will choose to specialize after dental school (ADEA, 2017). One can expect this will influence other practice decisions that have financial implications as well.

Pediatric dentists are specialists who have done advanced training beyond dental school with an emphasis on treating young children and children with special health care needs. They receive specialized training to handle the behavior of young children including those on the sensory disorder spectrum, and to be quick in performing procedures to align with the short endurance of young children. In 2017 only 7,778 were pediatric dentists (4% of dentists) (ADA HPI, 2017), not nearly enough to meet the primary dental needs of young children. Pediatric dentists tend to aggregate in larger urban cities, and close to 70% of them treat Medicaid and CHIP patients. Almost 60% of pediatric dentists also report using the operating rooms, providing an option for very young and special needs patients. Women now comprise 44% of the specialty. Pediatric dentists report that over 40% of their patients are under five years of age (ADA, 2012).

Financing of dental care

As a result of the Patient Protection and Affordable Care Act (PPACA), it is projected that 8.7 million children will gain access to comprehensive dental benefits by 2018, through Medicaid expansion, state health insurance exchanges and employer-sponsored plans with dependent coverage. This represents a 15% increase compared with 2010, and will reduce the number of children without dental benefits by 55%. This increase is expected to generate an additional 10.4 million dental visits per year through Medicaid by 2018 (Nasseh, Vujicic, & O'Dell, 2013).

It is also expected that these children who are gaining access perhaps for the first time will exhibit a higher burden of dental disease and treatment needs than the currently insured population. All of this points to the need for the current dental care delivery system to be able to expand productivity to absorb this sudden surge in demand.

Dentist participation in Medicaid

Reaching high-risk children in the first few years of life to prevent initiation and progression of disease is challenged by several aspects of the dental market and workforce, despite there being federally mandated programs designed to address this need. The dearth of dentists willing to treat young children is compounded by low participation in publicly funded programs, in large part due to low reimbursement rates. The American Dental Association (ADA) estimates that approximately 39% of dentists nationally participate in CHIP or Medicaid with a wide range across states (15.4 to 85.5%), and younger, female and pediatric dentists having higher participation rates (ADA HPI, 2018)

A survey of Florida dentists found that minority dentists (blacks and Hispanics) are more likely to participate in Medicaid than other groups of dentists. Pediatric dentists are also more likely to participate than general dentists. Non-Medicaid providers report not being busy enough in their practice more often than Medicaid providers do (Logan, Guo, Dodd, Seleski, & Catalanotto, 2014).

Medicaid's Early and Periodic Screening, Diagnostic, and Treatment (EPSDT) program requires states to fund well-child healthcare, along with any Medicaid-covered (i.e., allowed under the federal Medicaid statute) service necessary to prevent, correct, or ameliorate a child's physical health, which includes oral health (CMS, 2004) Thus Medicaid beneficiaries under age 21 are entitled to comprehensive dental benefits including preventive, diagnostic, and treatment services (CMS, n.d.), but at a minimum, services must provide relief of pain and infections, restorative services, and maintenance of dental health.

Reimbursement rates

Private dentists provide the majority of these services, which are paid for through fee-for-service reimbursements defined by each state. However, inadequate reimbursement rates have hampered programs' abilities to secure adequate provider networks. Across the U.S. the average rate of participation was 38.6% with wide variation across states, ranging from 15.4% in Maine to 85.5% in Iowa (ADA HPI, 2017). During budgetary constraints, states resort to lowering reimbursement rates or limiting the scope of services covered. For children, however, defunding federally mandated services is not possible. Instead, most states violate the "equal access clause" in the federal law aimed at ensuring "payments are sufficient to enlist enough providers so that care and services are available under the plan at least to the extent that such services are available to the general population in the geographic area"⁵ (Jessee, 2008). In other words, provider reimbursement rates for services to Medicaid recipients should be sufficient that an adequate number of providers enroll in the Medicaid program and accept Medicaid patients. This clause was meant to prevent states from improperly reducing reimbursement rates in an attempt to control program costs. However, in many states including California, Medicaid is one the largest components of the state's budget, and thus remains a target for cost reduction (Bindman, Chu et al., 2008). Harsh economic times increase the numbers of those eligible for public assistance programs, patients whose service need tends to average higher than the rest of the population. It is thus not surprising that many states such as California lower or limit provider reimbursements, causing provider participation to drop to suboptimal levels, and with it, access and appropriate use of services.

5. 42 U.S.C § 1396a(a)(30)(A) of the Medicaid Act.

Providers' reluctance to treat Medicaid patients

Further aggravating the financial losses of accepting Medicaid patients, providers consistently report time-consuming administrative processes that compare poorly to commercial insurers and patients with higher “no-show” rates. All of these are powerful disincentives to dentists’ participation in Medicaid with direct negative impact on access to oral health care for Medicaid beneficiaries (C. Lewis, Teeple, Robertson, & Williams, 2009; Milgrom, Lee, Huebner, & Conrad, 2010; Ramirez de Arellano, Wolfe, & Public Citizen Health Research Group, 2011; U.S. Government Accountability Office (GAO), 2008, 2009). Lewis reports that 74% of pediatricians cite lack of dentists to whom they can refer 0- to 3-year-old beneficiaries as a “moderate to severe barrier” to patients obtaining dental care (C. Lewis et al., 2009). Furthermore, a recent study in Illinois found that children with Medicaid were 18 times more likely to be denied an appointment for the same urgent oral injury as their privately insured counterparts (Blue Cross) by a practice participating in Medicaid. These practices scheduled 100% of Blue Cross patients but turned away 32% children with Medicaid (Rhodes & Bisgaier, 2011).

This situation led to several class-action lawsuits brought against states for not securing the dental services to which beneficiaries were entitled. In most cases, states increased reimbursements, at least temporarily. Increases in reimbursement rates have shown to be effective in increasing dentists’ participation both by attracting new providers into the network, and increasing the number of Medicaid patients that already enrolled providers are willing to treat (Borchgrevink, Snyder, & Gehshan, 2008; Eklund, Pittman, & Clark, 2003; Mayer, Stearns, Norton, & Rozier, 2000).

Alternate workforce models to fill the gap for underserved populations

The Institute of Medicine report on the “U.S. Oral Health Workforce in the Coming Decade” 2009 workshop highlighted evidence on how inequities in oral health outcomes in the U.S. results from the inability of the current workforce to meet the oral health needs of diverse populations. In light of persistent disparities and difficulty securing providers to treat vulnerable populations, several alternate, often highly politicized workforce models that maximize use of mid-level providers have emerged to meet the needs of underserved populations. These include:

- Community Dental Health Coordinator (CDHC) — ADA’s primary mid-level provider model.
- Dental Health Aide Therapist (DHAT) — high school graduates are trained for 24 months to provide culturally competent education and basic dental care to patients in rural Alaska as part of an integrated team. Their scope includes performing the following under general supervision of a dentist: diagnosis, restorations, prophylaxis, simple extractions, pulpotomies, and crowns.
- American Dental Hygiene Practitioner (ADHP) — a dental hygienist with a 2-year masters level advanced training to provide cost-effective dental care to underserved communities. Likened to the nurse practitioner model in medicine, their scope would include full hygiene in addition to simple restorations and temporary crowns, pulpotomies, simple extractions, and limited prescription writing for analgesics.
- Dental Therapist (DT) — based on the DHAT, the University of Minnesota offers basic DT and an advanced DT tracks, requiring a bachelor’s degree or two additional years, respectively. Advanced DTs may perform certain kinds of permanent extractions under direct supervision of a dentist, and basic DTs can perform primary extractions, pulpotomies, pulp capping, limited diagnosis, and atraumatic restorative treatment (Garcia, Inge, Niessen, & Depaola, 2010).
- Expanded Function Dental Assistant (EFDAs) and Expanded Function Dental Hygienist (EFDHs) — not new; these models were developed in the 1960s and ’70s but did not survive the intense political opposition of organized dentistry against any form of new workforce practitioner.

The Alaska DHAT was modeled after an 80-year-old New Zealand dental nurse model spurred a failed lawsuit by the ADA to stop its implementation. DHATs are hired either through Indian Health Services or a tribal health program. Several other states are considering adoption of the DT model, including Michigan, North Dakota, Ohio, Texas, Kansas, and Arizona

(Hoekstra, 2016). Opponents from the dental profession to this and other models suggest danger in creating a two-tiered model of care, one for that “haves” provided by dentists and another for the “have nots” provided by less trained or qualified providers. Professional dental organizations are most often in support of the CDHC or care management support staff working with community organizations as a complement to dental practices, and increases in reimbursement rates as a way to draw dentist towards serving greater numbers of Medicaid beneficiaries.

Few dentists treat young children

Another challenge for the pediatric population is the difficulty in finding dentists who will treat their young child; this is especially true of Medicaid beneficiaries. As discussed above, pediatric dentists comprise only about 4% of dentists. Historically, general dentists often prefer not to treat younger children under two or even three years of age. General dentists report limited experience treating infants and toddlers during their clinical training, and only about half of dental schools report exposing pre-doctoral students to this type of patient. Yet numerous professional organizations recommend a first dental visit by age one (Casamassimo & Seale, 2014).

Some surveys focused on understanding the level of participation of general dentists in caring for young children. A study by Seale and Casamassimo in 2003 indicated that a majority of general dentists in the U.S. do treat child patients. However, the details tell a different story:

- 9% reported not accepting children under age 14
- 73% refused to treat infants 6–18 months of age
- 28% did not treat children 19–36 months
- 2% did not see children between 4–6 years of age (Seale & Casamassimo, 2003).

Similar surveys were conducted in Iowa, Connecticut and Virginia. In Virginia they found that though 100% of pediatricians treated young children, 89% of general dentists did not see patients

in their office until they were three years of age (Brickhouse, Unkel, Kancitis, Best, & Davis, 2005).

Furthermore, when dentists were asked how often they treated child patients covered by Medicaid, even fewer children made the cut:

- Over 50% indicated they never saw Medicaid beneficiaries ages 4–15 years.
- Almost 60% never saw children with Medicaid coverage who had even mild caries.
- Only 7% indicated they treated the very young (6–36 months) very often or often.

So while dentists report treating children, in general young children under 4, children with high levels of caries, and children covered by Medicaid are treated in low numbers (Seale & Casamassimo, 2003). On the other hand, practices that see a higher proportion of Medicaid enrollees generally tend to see more young children (Garg et al., 2013).

More recent dentist surveys suggest that there have been some improvements in general dentists' willingness to treat young children. Another recent survey of Iowa dentists treating privately insured children found that only 18% of general dentists treat children under two (up from 6% in 2005). Another recent survey of New York dentists found that fewer than 47% of general dentists see patients aged 0–2 years. Similar to previous surveys, older providers that have been in practice more than 30 years were less likely to see young children than providers that had been in practice for less than six years (42% vs. 70%), and female dentists were more likely to treat younger patients. The observed improvements could be related to increased exposure to infant care in dental training programs, or the general increase of female representation among young dentists.

Data suggests that the main reasons for not seeing young children is discomfort with small children (56%), disruptive behavior (31%) and inadequate reimbursement (25%) (Garg et al., 2013).

Age of first dental visit

The American Association of Pediatrics (AAP), the American Academy of Pediatric Dentistry (AAPD), the American Dental Association (ADA), and the American Association of Public Health Dentistry all recommend children visit a dentist within six months of eruption of the first tooth or no later than one year of age (AAPD, 2015; AAP, 2003, 2014; American Association of Public Health Dentistry, 2004; ADA, 2000).

The 2003 survey discussed above also found that only slightly more than a half of respondents were aware of the ADA and AAPD recommendations for a first dental visit by age 1; of those who were aware, 60% did not agree with the recommendation. Only 15% of the respondents identified one year as an appropriate time for the first visit, while 40% recommended 30 months or three years as the appropriate age for a child's first dental visit (Seale & Casamassimo, 2003). In 2008, a survey of Virginia general dentists, pediatric dentists, and pediatricians reported 74% of pediatric dentists recommended the first dental visit be within the first year, but only 12% of general dentists and 5% of pediatricians made this recommendation. General dentists and pediatricians were more likely to recommend the child's first dental visit occur by age three (49% and 69% respectively). Though 100% of pediatricians treated young children, this survey found that 89% of general dentists did not see patients in their office until they were three years of age (Brickhouse et al., 2005). Like other contemporary surveys in Iowa and Connecticut, more recent dental graduates (in practice less than 10 years) and female general dentists were more likely to refer for a one year visit and be willing to see 0–2 year old children (Santos & Douglass, 2008; Wolfe, Weber-Gasparoni, Kanellis, & Qian, 2006). General dentists are also more likely to refer young patients who are uncooperative, have severe decay, or special needs to pediatric dentists.

Training of general dentists in infant oral health

There have been mixed responses by dentists regarding how prepared they feel to handle young children. This plays a role in refusing treatment in their practices. However, studies link exposure to infant oral care during dental training to increased motivation and willingness to treat them (Rich III, Straffon, Inglehart, & Rohr Inglehart, 2006). Casamassimo and Seale (2014) report about half of dental schools expose pre-doctoral students to infant oral health and an opportunity to develop associated competencies, but their experience here is typically not representative of what it would be in actual practice. It is often the case that selection of patients for pre-doctoral education tends to yield a pool of well-behaved, low disease complexity, and adequately financed children for learning purposes. Higher complexity patients with behavior issues would be more appropriate for residents in pediatric dentistry post-doctoral training programs. It is not surprising therefore that, barring other clinical exposures, general dentists would limit their practice to the type of patient they learned to treat in dental school and refer the rest to the pediatric dentist.

Despite accreditation standards that specify that graduates of dental education must be competent in caring for patients of *all* ages within the scope of general dentistry, Casamassimo suggests that “the expectation that graduates emerge competent in provision of real world pediatric dentistry is naïve at best.” Aligning with his assessment are dental faculty’s report of inadequacies in the training of dental students to manage young children with extensive caries (Casamassimo & Seale, 2014).

Rationale and benefit of early establishment of dental home

There are several compelling reasons why starting dental care by age one is beneficial, not just for the patient’s health but also for the delivery of dental care. Firstly, starting care early provides

the best opportunity for early identification and intervention into the risk factors for caries (James J. Crall, 2005), and educates parents on how to best care for their child's oral health and establish healthy habits. Secondly, from a behavioral perspective, allowing young patients to experience their first dental visit in a positive, comfortable context where the dentist can be fun and deal with healthy teeth, and the child does not have to endure discomfort, can influence both the child's future behavior, the relationship with the dentist, and the dentist's willingness and ability to manage them. This experience can also help reduce the anxiety level of parents over the child's dental care, especially if they have had poor oral health and dental experiences. When restorative services are needed at a young age, young children often pose a significant challenge for behavior management that most general dentists are not equipped or willing to handle. Thirdly, early visits and management of risk and disease can help maintain disease at a level that general dentists are equipped to treat without referring out to a pediatric dentist. Finally, several studies suggest early initiation of dental care produces both improved health outcomes and cost savings (Pienihäkkinen & Jokela, 2002; Pienihäkkinen et al., 2005; Savage, 2004)(Pienihäkkinen & Jokela, 2002; Pienihäkkinen et al., 2005; Savage, 2004).

Studies have shown that preventing the onset of ECC is more cost effective than treating advanced caries. Savage and Lee analyzed administrative data for Medicaid children from birth to age five. They found that children who had their first dental visit by age one were more likely to use preventive services and not more likely to have restorative or emergency visits, in contrast to those with visits between two and three who had more preventive, restorative and emergency visits. The age of first visit also had a significant effect on future dentally related expenditures, with lower spending for those with earlier initial visits (Savage, 2004).

Addressing Oral Health Disparities

Barbara Starfield (2011) talks about two types of inequities in the healthcare system: horizontal and vertical. Horizontal inequity arises when people with the same needs do not have access to the same resources. Vertical inequity exists when people with greater needs do not receive greater resources. The Affordable Care Act is helping address horizontal inequities in access to dental care. Public health programs have a role in improving access for vulnerable populations. However, vertical inequity is resolved in the financing, management and the delivery of clinical services. A risk and disease management approach to dental caries encompasses the clinical and practice management aspects, which also need to be supported with the appropriate financing structures and an aligned public health program.

Gary Rozier (2017) commented recently that progress in prevention policies and programs that affect disease experience appears slower than progress in meeting population-level caries treatment needs. Longstanding inequities related to politics and social determinants remain for caries, raising ethical and public health concerns that demand attention and problem-solving capabilities. Dentists can lead the charge toward value care in a way that does not completely threaten their profession while at the same time provides care to all.

A risk and disease management approach that starts early in life can have significant effects on all parts of the system that could work together for the good of all. A national acceptance of this approach by all dentists could look something like this as described by Seale and Casamassimo:

General dentists see children and establish prevention in dental homes, having learned those skills in dental school. Prevention reduces the number of children with early childhood caries. Participation in the dental home allows the general dentist to identify early carious lesions and act with minimal invasiveness. The number of children with severe early childhood caries declines

and becomes manageable in existing referral patterns to pediatric dentists. The challenge to the general dentist to provide extensive behavior management and restorative care decreases dramatically. (Casamassimo & Seale, 2014)

Rasanathan et al. (2011) stated in relation to primary care that health services that do not consciously address social determinants “exacerbate health inequities.” There is a need for the whole profession of dentistry to consider how dental services are consciously addressing social determinants so that they are not inadvertently exacerbating oral health and dental care disparities. In addition the partnership between public health and dental delivery systems can be better articulated towards the goal of value care to achieve dental health and minimize surgical interventions. We can look to Europe for examples of productive partnerships between public health and dentistry.

Oral health outcomes and effectiveness of care

Two significant barriers prevent the further development of quality measures in oral health: a dearth of evidence-based standards and guidelines, and the lack of universally accepted and used diagnosis codes in dentistry. Dental research is challenged in part because with the typical small practice design, it can be difficult to collect outcomes data due to the need to gather data from multiple practices as well as integrate the variety of forms that are used to collect the same data (Bader, 2009). The practice design also makes it difficult to disseminate evidence when it exists; most dentists work alone, so information sharing is limited, and few have chairside access to journals or computers (Bader, 2009).

The absence of a universally accepted set of diagnosis codes among dentists also is a barrier to developing quality measures (Bader, 2009; James J. Crall, Szlyk, & Schneider, 1999; Garcia et al., 2010). The Dental Quality Alliance released its guide to dental quality measures in June

2016. The first set of measures released were pediatric dental measures. Only one of the 10 quality measures is an outcome measure, and it relates to emergency department visits for caries-related reasons. The rest are process measures or measures of utilization and access. This highlights the challenges of assessing quality within current practice (American Dental Association, 2016).

Oral Health and Provider Productivity

The statistics discussed thus far highlight the size and growth of expenditures on dental care but also a continuing challenge for population health – the gaps in access to dental care for a portion of the population that has not changed for decades and excess dental price inflation. Of the annual growth in dental spending, about 2–3% is attributable to dental price increases, over and above the rate of inflation, but little of the increase is attributed to increased productivity of dental operations (Bailit & Beazoglou, 2008). Overall dental spending is increasing, but it appears to be focused on a certain socio-economic strata, since the proportion of the US population that continues to lack access to quality oral health continues mostly unchanged.

Various strategies have been proposed and attempted to reduce these disparities and shortfalls of the dental care sector. These have included federal and state support for workforce development that provides funding for pre-doctoral and residency training programs and loan forgiveness programs to lure young providers to practice in underserved areas. In addition, the reluctance of dental providers to accept Medicaid patients has resulted in several (successful) class-action lawsuits against state agencies on behalf of Medicaid beneficiaries that has led to varied levels of increase in reimbursement rates, and subsequent provider recruitment and increases in services.

A different response from several advocacy communities in the last decade in particular has brought to the forefront the use of mid-level practitioners to fill the gap and provide preventive and educational services for most vulnerable populations. The dental therapist was first considered for remote areas of Alaska but has since expanded to other states that have authorized dental therapists including Minnesota, Maine, and Vermont. Several other states are exploring or piloting the model (Koppelman, 2016). Other strategies have included engaging partners outside of dentistry to capture children at high risk of disease at an early stage. This includes primary care providers serving children, as well as other community partners serving disadvantaged families through programs such as Head Start or the Women Infants and Children (WIC) Supplemental Feeding program.

While many of these strategies have shown varying levels of success in improving access and entry into the dental care system, they are often not sustainable without continued funding to support program coordination and attention to this population. With limited ways to monitor quality of care and oral health outcomes, it is not clear if these high-risk patients, once they enter care, receive care that is fitting to their individual needs and risks, or whether it improves their long-term oral-health outcomes. A suggested alternate practical mechanism for improved dental care performance and to close the gap in services is to improve the productivity of the existing system (Conrad, Lee, Milgrom, & Huebner, 2010).

Productivity is a major driver of the capacity of the dental service system. Yet there is a paucity of published information on structure and process variables that affect dentist productivity, let alone any using outcome measures of effectiveness. Recent work by Conrad et al. (2010) updates and is consistent with previously published work (Lipscomb & Scheffler, 1975; Scheffler & Kushman, 1977), that found that dentist productivity is influenced largely by

the hours dentists worked, and smaller contributions by the number of assistants, hygienists, or operatories. The studies also found that practice ownership and the dentist's years of experience were positively correlated to productivity (Conrad et al., 2010; Jurasic et al., 2013). These studies mostly examine process and structure variables such as the effects of changing inputs, such as using dental assistants or expanded function auxiliaries on the production function (Bailit, Beazoglou, DeVitto, McGowan, & Myne-Joslin, 2012; Beazoglou, Bailit, DeVitto, McGowan, & Myne-Joslin, 2012; Overstreet, Dilworth, & Legler, 1978). Alternately, the number of services provided, billing, and relatively value units (RVUs) have also been used as a measure of productivity (Arevalo, Saman, & Rohall, 2011).

These studies suggest there are better ways to measure productivity, even if data is difficult to capture. Conrad et al. (2010) conclude their discussion with several recommendations for future studies on dental productivity. They suggest that to achieve greater influence on policy and practice studies should consider:

- 1) measuring output in terms of its contribution to oral health, not just visits;
- 2) measuring space utilization more precisely; and
- 3) including patient mix with regards to demography and oral health.

Gutacker et al. discuss the challenges of measuring dentist productivity, suggesting that the ideal measure of patient care would combine both quality and quantity provided. However, the reality is that these types of outcome measures are not routinely collected or even documented; most studies resort to measures of activity, time or monetary value. Activity measures, such as number of patients treated or patient contacts, though general easily retrieved, is a blunt measure of output as it assumes homogeneity across dental practices with respect to patient need (i.e., oral health) and implicitly assigns equal weights to different types of visits (check-ups vs. complicated restorations) (Gutacker, Harris, Brennan, & Hollingsworth, 2015).

Since lack of quality data is still a constraint, the current study explores the use of computer simulation models to generate the ideal type of data, both qualitative (oral health) and quantitative (visits and patients). By generating and using this type of oral health outcome data I hope to inform and extend our understanding of system dynamics and possible impacts of preventive and restorative services on oral health and productivity. This study explores whether a risk-based approach to care could have an effect on productivity mediated through improvements in oral health of the patient population. If so, this could provide evidence on a qualitative way for dentists to expand output while meeting the needs of high-risk populations within their current structure, and perhaps current reimbursement schemes. This last aspect, however, is beyond the scope of this dissertation.

As the prospect expands of moving into an area where payers push for more value-based reimbursement, many dental programs are wondering how to restructure dental productivity strategies to meet the unique requirements of performance-based payments. Some have suggested that the key is to incorporate patient experience into productivity goals to boost the organization's bottom line. It might be more difficult for smaller dental practices to align with productivity strategies in a value-based reimbursement system. However, changing orientation to prevention and disease management is a promising strategy to help position them well for the next era of value-based dentistry.

Chapter 2 Summary

This chapter introduces the magnitude of the problem caries disease represents and the human and economic costs it poses on our society. Furthermore, given that the simulation model in this dissertation models caries disease and the dental care process, I provide background on what we

know about caries disease, its risk and protective factors, and describe characteristics of the dental care delivery system in the U.S including the workforce, financing and practice models. I provide a detailed description of a risk assessment and disease management approach to care compared to a traditional one-size-fits-all approach that is the focus of this dissertation. This begins to paint the complex web of interactions that result in significant oral health disparities. Finally, I introduce literature on provider productivity, and some of the limitations that traditional methods encounter that system science can help address.

Chapter 3. Conceptual Approaches to Analyzing Oral Healthcare System

The Surgeon General's National Call to Action (2003) recommended research designed to determine the complex interactions of the biological, social and environmental influences on oral health. Included in those recommendations was a call for health services research that explores how the structure and function of health care services affect health outcomes. In order to effectively transfer science into private practice, there is a need to promote effective disease prevention measures that are underutilized, as well as to explore ways to incorporate research into delivery and reimbursement system (U.S. Department of Health and Human Services, 2003). In the last several decades there has been much research on how to extend or expand workforce capacity and productivity to address oral health, especially in shortage areas, mostly through alternate workforce models (P. Brocklehurst, Mertz, Jerkovic-Cosic, Littlewood, & Tickle, 2014; Mckinnon et al., 2007; Mertz & Glassman, 2011; Skillman et al., 2009; Tsai, Wides, & Mertz, 2014; Wanyonyi, Radford, Harper, & Gallagher, 2015) or inter-professional collaborations (Anderson, Self, & Carlson, 2017; Dolan, 2015; Fried, 2013; Haber, 2014; Hummel J, Phillips KE, Holt B, 2015; Mertz, 2016; Mertz & Finocchio, 2010; Mouradian & Corbin, n.d.; Pyle & Stoller, 2003; Ramos-Gomez, 2014; Shimpi et al., 2016; Wilder, 2013).

My project intends to add to this body of evidence by taking a system science approach to explore areas and dynamics that have hitherto been inaccessible or obfuscated by the requirement and limitations of our statistical and conceptual models. In this chapter I review features of complex adaptive systems germane to both population health and care delivery systems. To provide a conceptual bridge to this new way of thinking about and approaching

public health problems, I will show how commonly used conceptual models in oral health capture dynamic and complex properties of population and healthcare systems.

Population health and healthcare systems have important of feedbacks and interactions both in and between these two systems. Thus I will argue that a conceptual model concerned with oral health and use of dental services should consider the structure and characteristics of the health system context and providers, in addition to those influencing individual behaviors. Both of these contribute to the quality and quantity of patient-provider interaction during the process of dental care. Most previous studies include health system characteristics as a context for care, but contain few delivery side factors at the level of the community or individual providers that could affect the patient-provider interaction. Understanding the drivers on both sides of the care delivery equation is important, as is the process of care itself and its outcomes.

I have developed a conceptual model (Figure 7 on page 124) aimed at situating this study within the traditional oral health services and disparities research literature. In this model, I draw heavily on Andersen's behavioral model, making more explicit certain feedbacks and interactions between levels influencing the health care encounter from both the patient and provider perspective. I also developed a set of two theoretical and analytic frameworks (Figure 8 and Figure 9 on page 141) to describe the mechanism and pathways at the individual and system levels relevant to the simulation model. It is the basis for the simulation model and draws on system-science concepts to capture the dynamics of processes, including feedbacks and accumulations within and across levels of influence and over time.

Complexity in Population Health and Healthcare Delivery Systems

Complexity science is the interdisciplinary field that studies the behavior of systems; it provides analytic lenses to study systems where the whole cannot easily be determined from consideration of its individual parts (Kaplan, Diez Roux, Simon, & Galea, 2017). A system is a group of interacting, interrelated, or interdependent elements forming a complex whole.

Not all systems are complex. Some systems are simple, where an action on one part of a system, creates an equal or linearly related reaction in another part of the system, one variable is wholly dependent on another; the outcome is fully knowable and therefore predictable. The trajectory of a projectile can be predicted based on the force with which it is thrown and the angle. Other systems are complicated; they are still deterministic, but because they have many moving parts and sequences they become very complicated, like the engine of a car. What makes systems complex? The interactions of heterogeneous agents or elements in a system result in a system behavior that is non-linear and often unpredictable. These interactions result in feedbacks, sometimes reciprocal or reinforcing, other times balancing. Over time these dynamics shape a pattern of behavior of a system “emerges” as the system can self-organize into a whole that is different from its parts. The feedbacks also mean that systems reacting or adapting to changes in the parts or elements. So the interconnectedness is central to its behavior and to the challenges such systems pose for researchers. System science provides a conceptual framework that emphasizes the relationships between parts of a system rather than the parts themselves. Table 2 further describes features that are generally associated with complex adaptive systems.

In undertaking a study of population oral health and the delivery of dental services it is important to recognize that

- 1) population health is a complex system, and
- 2) healthcare delivery systems are also complex (Bar-Yam, 2004, 2006; El-Sayed & Galea, 2017).

The interaction of the two is ever more complex!

Population health is concerned with the studying the health outcomes of groups within a population, and the distribution of health outcomes within these groups. It is complex because individuals interact to produce aggregate behaviors in varying contexts, all of which feed back upon and shape the health of individuals (El-Sayed & Galea, 2017). A fundamental goal in studying population goal is understanding the relationship between behaviors of individuals and

Table 2. Characteristics and Language of Complex Adaptive Systems

1.	Interaction of heterogeneous agents
2.	Simple rules — agent respond to each other or their environment based on internalized rule sets that drive action.
3.	Nonlinear — system-level behavior is often unpredictable and nonlinear. Small changes in initial conditions can generate large changes in the system’s outcome. Complex systems often exhibit what seems like chaotic behavior, but at the right scale can be seen as a pattern. The whole is greater (or different) than the sum of the parts.
4.	Governed by Feedbacks — Interdependence, tightly coupled, reciprocal, mutual causation. Actors in a system interact strongly with one another and the environment, everything is connected.
5.	History-dependent with Time delays — Some actions are irreversible, others result in accumulations or time delays resulting in system behaviors.
6.	Emergence and Self-organization — Bottom Up organization, leaderless. Emergent properties or patterns of behavior emerge from the interaction of agents who follow simple rules without external/central control or a leader, and feedbacks among agents and elements of the system – like the movement of a school of fish or cycles in the real estate market.
7.	Adaptive and evolving — if elements of the system are altered, the system reacts or adapts. Since agents within a system can change, the system behavior can adapt its behavior over time. Agents can change their behavior by learning new ways to achieve their goals. However, learning is not always beneficial; because of bounded rationality of agent’s decisions often maximize local, short-term objectives at the expense of long-term success.
8.	Tradeoffs between short-term and long-term system responses. Time delays and feedbacks means that often a system’s long-run response to an intervention is different from its short run response. This has implications for the sustainability of changes/interventions.
9.	Dynamic and counterintuitive — Behavior patterns emerge over time and cannot be captured by simply looking at a point in time. In complex systems, cause and effect are distant in time and space, whereas we tend to look for causes near the events we seek to explain. High leverage policies are often not obvious because we are drawn to symptoms of difficulty rather than the underlying cause.
10.	Policy Resistance — the tendency of systems to resist changes to interventions. This relates to the simple rules and bounded rationality; the complexity of systems goes beyond our ability to understand them and often our actions or seemingly obvious solutions to problems fail or even worsen the situation.

Adapted from Sterman, 2000.

populations, in service of understanding and to design effective interventions to prevent disease and improve well-being. Population and public health problems, such as obesity, tobacco use, addiction, and health disparities are now all consistently described as complex problems or “wicked problems.” Because they are deeply embedded within the fabric of society, the factors underlying both behavioral causes and solutions are also complex (Kahan, Gielen, Fagan, & Green, 2014)

With the rise of chronic diseases, it is even more apparent that health care is but a fraction of what contributes to the health of individuals and populations. However, it often provides an important platform for prevention and to motivate behavior change. Healthcare delivery systems, in this case for dental care, also exhibit characteristics of complex adaptive systems. The system’s performance and behaviors change over time and cannot be completely understood by simply knowing about the individual components. Across disciplines and all levels, health care is becoming more complex (Plsek & Greenhalgh, 2001).

Difficulty in studying populations arises from different forms of complexity:

- human health and disease is deeply complex
- biopsychosocial predictors of health and illness, including food choices and other health-related behaviors
- the influence of culture, gender, ethnicity, and socioeconomic status are significant factors influencing health and disease
- genetics and interaction with environment and experiences
- local policies and characteristics influencing access to care

Even two of these elements can act together to produce complex effects, and often more than that are at play.

A complex adaptive systems approach challenges simple “cause and effect” assumptions; instead, it sees healthcare and other systems as “dynamic” processes characterized by constant

change, activity, or progress. In complex systems the interactions and relationships of different components simultaneously affect and are shaped by the system (The Health Foundation, 2010).

Recognizing that population oral health and dental care delivery systems share these characteristics of dynamic and complex adaptive systems is a reason to pursue methods and frameworks that match these characteristics. First, I will explore some of the most oft-used conceptual models in health services and oral health to find where and how these concepts have traditionally been captured and operationalized. Then I will discuss the systems thinking tools and methods for analyzing complex adaptive systems to introduce a demonstration of how these methods can be applied to a public health problem.

Conceptual Frameworks of Oral Health and Dental Care Delivery Systems

In the following section, I will review examples of how dynamic aspects of systems have been included in a sample of traditional conceptual models used over the years to study the use of dental care services and influences on oral health. I will also posit that oral health disparities researchers have focused much more on understanding the influence of social determinants on the individuals' oral health and use of dental care while focusing much less on the influences on provider behaviors and the quality of the patient-provider interaction and its effect on determinants and structures.

The complex dynamics of health systems and population health

For the last several decades contributions from the fields of sociology, psychology, epidemiology, and population health have helped frame our understanding of individuals' health-

related behaviors and use of services as part of a complex web of influences. The importance of the multiple levels of influence on individuals' health behaviors and outcomes, including biopsychosocial and environmental determinants, has been widely accepted and included in various frameworks focusing on dental care and early childhood caries (Finlayson, Siefert, Ismail, & Sohn, 2007b; Patrick et al., 2006; Peres et al., 2005; Reisine & Douglass, 1998; Sheiham & Watt, 2000; Watt & Sheiham, 2012). Among frameworks primarily focused on use of oral health services and oral health are the following three models I will review:

- *Andersen behavioral model of health service use* (Andersen, 1995, 2008; Andersen & Davidson, 2007; Baker, 2009) adapted to oral health and dental services.
- *Fisher Owens conceptual model of influences on children's oral health* (Fisher-Owens et al., 2007).
- *Lee and Divaris framework to eliminate sources of oral health disparities* (J. Y. Lee & Divaris, 2014)(J. Y. Lee & Divaris, 2014).

These can be categorized as predictive models aimed at maximizing the ability to explain variance in service use in populations (Grembowski, Andersen, & Chen, 1989) and population health, or more specifically aimed at understanding pathways to intervene in the creation of disparities. These models have indeed recognized and conceptualized dynamic properties and mechanisms of systems, while at the same time acknowledging shortcomings when it comes to operationalizing these dynamic properties in their frameworks based on the constraints of statistical methods, logistics, cost, and available data.

The properties discussed fall in the following categories:

- 1) multilevel influences,
- 2) time and time delays,
- 3) reciprocal and interactive relationships, and feedback loops

Multi-level influences

Context has been increasingly identified as an important influence on health and health care (Gift, 1997; Koczwara et al., 2016; May, Johnson, & Finch, 2016; Phillips, Morrison, Andersen, & Aday, 1998; Tomoaia-Cotisel et al., 2013). Over the last several decades there has also been a growing recognition of the multiple levels of influence on health and health utilization. All of the models in this review emphasize the multilevel nature of the determinants of oral health and use of dental care, even though they might conceptualize or categorize the levels in slightly different ways. This is the most often referenced and applied aspects of the frameworks. Much of the research on oral health and dental care continues to focus on linear relationships and associations between social determinants and use of services, rarely including determinants in more than one level, and only sometimes including oral health outcomes, instead of just service utilization or procedures.

Andersen Behavioral Model of Health Services Use — The oldest and most widely employed conceptual model used to explain disparities in dental visiting has been the Andersen Behavioral Model of Health Services Use (Figure 4). A major goal of this model was to provide

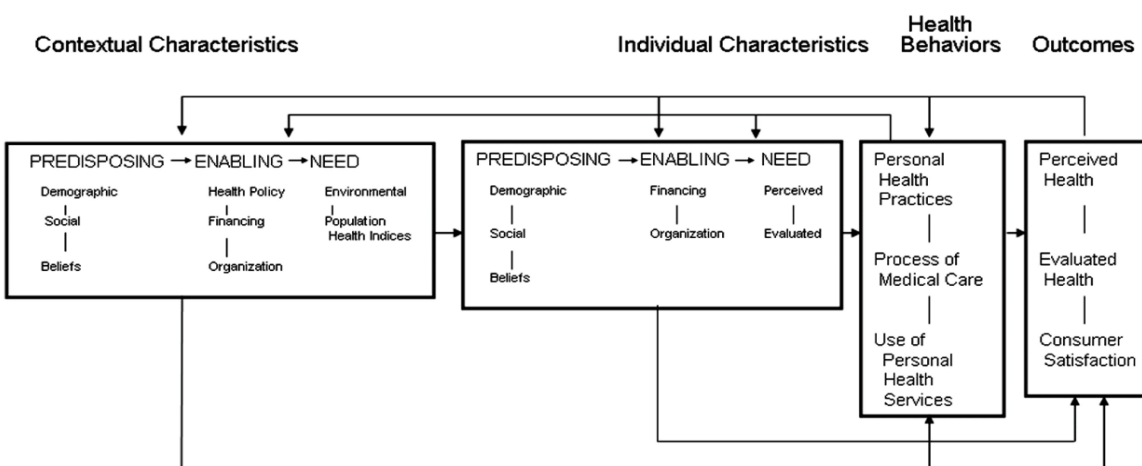

Figure 4. Andersen's Phase 5 Behavioral Model of Health Service Use including contextual and individual characteristics (Andersen, 2008).

a measure of access to medical care; it was later adapted for dental care. This multilevel model has evolved over the last 50 years to account for both individual and contextual determinants of service use. First developed in the 1960s, it offered the concept that use of services is a function of individuals' "predisposition to use services based on a number of demographic and social factors and associated beliefs, factors which enable or impede use, and their need for care" (Andersen, 1995). The model conceptualized health behaviors (oral health practices and dental services utilization) as intermediate dependent variables, which, in turn, influence oral health outcomes (evaluated, self-perceived, and patient satisfaction) (Andersen & Davidson, 1997). Research focused on how mutable these various factors were to be appropriate targets for intervention. Later versions acknowledged the value of not just use of services, but the final health outcomes, which included satisfaction with care. At the time, the conversation also included the concepts of realized, equitable, and effective access. Andersen refers to equitable access as the kind that results when demographic and need variables determine who gets care, while effective access is established when use of health care effectively improves health status or satisfaction (Andersen, 1995).

In 2008 Andersen published Phase 5 of the model, which had two additions of particular interest to my study. The first addition emphasizes the understanding that health service use is best accomplished by focusing on both contextual and individual characteristics. The second addition, which I will discuss later, has to do with the process of care. The framework thus posits that characteristics of the external environment, such as the dental care delivery system, and the personal characteristics of the population influence oral health behaviors. Andersen proposed that contextual characteristics could also be thought of in the same way as the individual

determinants were — those that predispose, enable, or suggest need for individual use of services (Andersen, 2008).

In this model, *predisposing* characteristics include demographic characteristics, social structure, and health beliefs; *enabling* refers to both community and personal enabling resources such as health policies, financing, and organization of health services, as well as income and insurance at the individual level; *need* prompts care-seeking and includes both perceived and evaluated health condition at the individual and population or community levels.

Fisher-Owens Model — One of the most well-known models used to frame the influences of on the oral health of children is the Fisher-Owens model, developed by a team at the University of California, San Francisco (Fisher-Owens et al., 2007). This model (Figure 5) drew from previous population and oral-health models extending the biological influences to also include the psychosocial and behavioral, much like Andersen's Behavioral Model. Fisher-Owens has an ecological approach to this multilevel multidimensional model that addresses the interconnectedness between behavior, biology, and environment. It starts with an adaptation of the classical Keyes Triad, a biological model for caries development that considers the interaction of three components: the microflora with substrate and diet on the host's teeth within the mouth (3) over time. This operates within concentric circles of child- (6), family- (8), and community-level (8) influences on children's oral health (Fisher-Owens et al., 2007).

Though not the only model developed specifically for oral health, Fisher-Owens is the only one of the four that accounts for the most proximal biological and behavioral factors contributing to the caries balance in the mouth (Keyes triad). It is also child-focused and therefore specifically acknowledges the health of the child within the context of the parents' and family's health status and health behaviors.

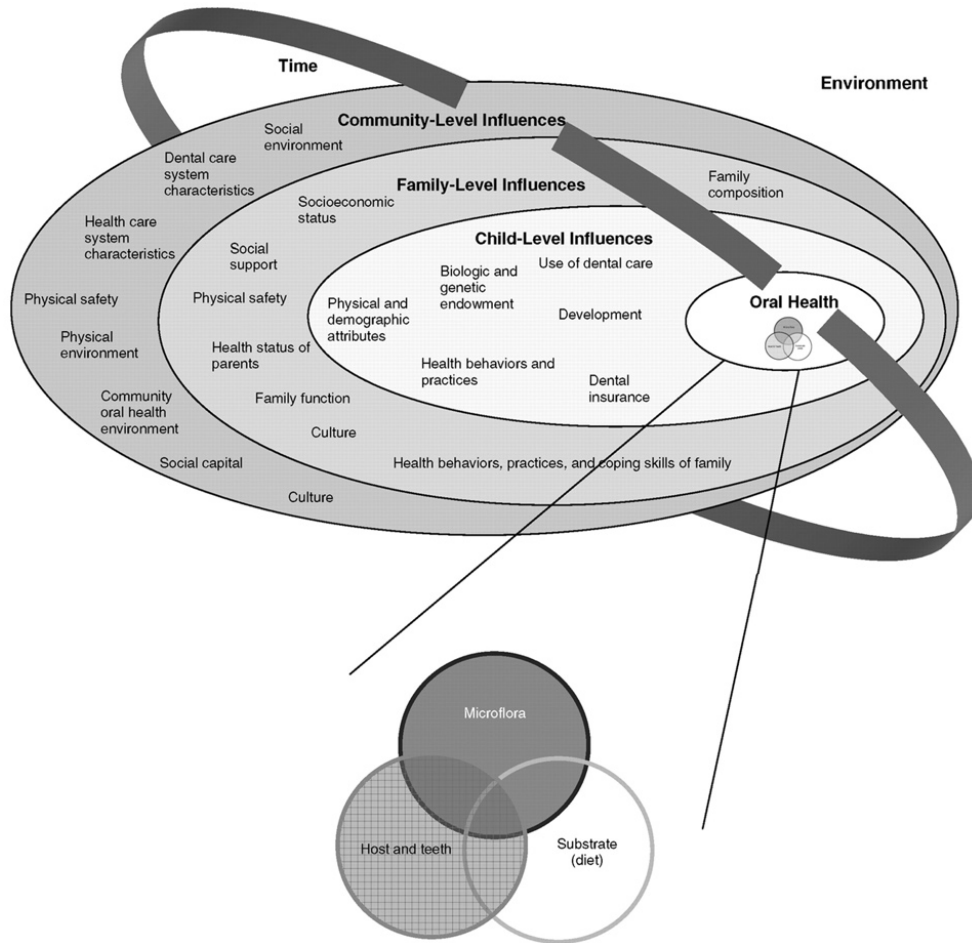

Figure 5. Fisher-Owens conceptual framework of the influences on child oral health.

The developers of this model discuss complexity concepts. Fisher-Owens et al. (2007) state that “key concepts in the development of a theory for oral health include multiple levels; interactions across levels, time, and space; equilibria and feedback loops; and the concept of vulnerability and resilience.” They recognize the need to capture cross-level interactions and feedbacks, understanding that this is what makes health a dynamic, evolving system. Most often, however, the application of this model has been cross-sectional or prospective cohort studies looking at associations between specific family or parent factors and child health, or child factors with health outcomes.

My own review of articles referencing the Fisher-Owens model reveals that the model is most helpful in conceptualizing levels of influence on child oral health, rather than providing a robust analytic framework for studies. Most articles reference the model to support a statement of the complex interactions, multilevel influences, social determinants, and/or factors associated with disparities. In other words, helpful in depicting the complex array of etiological factors that potentially influence disease development, but limited in its ability to explain pathways or mechanisms involved (James J. Crall & Forrest, 2018). Casamassimo comments that “we do not invest enough in using these relationships to effect change. They too often remain sociological curiosities that the scientific community has difficulty translating into action” (Casamassimo et al., 2014).

Lee & Divaris Model — From the University of North Carolina, Chapel Hill, Lee and Divaris proposed another conceptual framework to outline the role of social determinants and identify pathways that might lead to disparities and potential interventions (J. Y. Lee & Divaris, 2014). This model incorporates several aspects of Andersen’s health behavior model of health service use, while also expanding on the contextual factors with some macro-environment concepts that Patrick et al. contributed, such as the political/economic and social influences. There is a more precise differentiation between the macro levels and community levels in this model. While they include predisposing and enabling resources, they do not include need. Neither does Fisher-Owens specifically, perhaps because they focus on oral health, while use of services is a mediating factor. Like Fisher-Owens, Lee includes health-system-level characteristics as a community level factor. These do not seem to interact with or affect other factors or pathways, but they do acknowledge several important provider-related factors that

others do not, such as cultural and linguistic skills of the provider, prejudice and stereotypes, and use of evidence-based practices.

Dimension of time

All of the above models include the dimension of time, recognizing changes of the life course and the progressive nature of oral diseases. Although Andersen does not explicitly depict time in the visual model, he does describe it as part of the model conceptualization.

Changes over time is a feature of complex and dynamic systems; “time delays” have profound influences on the function and structures of systems. Time delays cause people to not intuitively link factors or identify relationships influential in a system due to physical or chronological distance. Furthermore, the cross-sectional nature of most study designs and difficulty in capturing longitudinal data hinders our ability to capture the effect of time delays. Thus they are rarely included in studies. Baker (2009) suggests that one of the explanations for results that are counterintuitive and perhaps erroneous with regards to contextual and individual-level determinants and oral-health outcomes is the use of “temporally mismatched data” and the assumption of equidistance in the Andersen model. She suggests, for example, that toothbrushing is more proximal (closer in time to health outcome) than attendance at a dental visit, which itself reflects unmet need and is more distal. Therefore, use of dental services would be further back in the causal chain and may act via a number of other intervening variables.

Reciprocal relationships, interactions, and feedbacks

Let us begin with some definitions of what we mean by reciprocal relationships, interactions, and feedbacks.

Reciprocal relationships are reflected in the theory that one's behavior both influences and is influenced by both individual factors and the environment, and that the environment both influences and is influenced by the individuals within it. (Kahan et al., 2014).

Interaction is a particular way in which parts of a system act or respond to each other. It has been defined as “mutual actions affecting the behavior or nature of the objects, bodies, phenomena or influence” (Morin 1977 as cited by Debarsy, 2017)

A feedback loop refers to a situation where part of the output of a situation is used for new input, an “effect” returning to its “cause,” which can cycle infinitely. Feedbacks are what run complex systems. They can be reinforcing (positive or negative) or balancing.

All of these terms relate to the ongoing nature of changing systems. Authors of the models under discussion all acknowledge and in some way represent these complex dynamics to varying degrees. Unfortunately, it seems these dynamics are left exclusively in the domain of theory; I found no applications of these models where these dynamic relationships were studied.

While predisposing, enabling, and need variables at the contextual and individual levels are the factors from Andersen's model most often used in research studies of access to care, important additions appeared in Phase 4 and 5 of the model development which emphasize concepts of complex systems. Phase 4 introduced the dynamic and recursive nature of health-service use that included health-status outcomes. Phase 5 added the “process of medical care” (or dental care in adaptations) as a type of “health behaviors” in reference to the behavior of providers interacting with patients in the delivery of care (Andersen, 2008). Up until then, health behaviors included only use of health services and personal health practices. Andersen points out that “it also includes feedback loops showing that outcome, in turn, affects subsequent predisposing factors and perceived need for services as well as health behavior.” This is a

feedback loop I will investigate; oral health outcomes affecting future need for dental care as well as contextual population health.

Andersen's framework also acknowledges important dimensions not typically referred to:

- 1) the importance of examining use in the context of health outcomes;
- 2) the interaction of personal health practices with the use of formal health services and its influence on health outcomes, which leads to
- 3) characterizing access with regards to its effectiveness and efficiency and the role of how the provider delivers care and interacts with patients.

This addition brought to light the importance of how the providers interact with patients.

Andersen recognizes the dynamic and feedback mechanisms between the delivery of services and both the individual and macro characteristics; the model has arrows in both directions. However, most often in the implementation and adaptation of the model, the arrows are redrawn unidirectionally, and the analyses follow suit (Ramraj, Azarpazhooh, Dempster, Ravaghi, & Quiñonez, 2012 is an example). In the context of a statistical approach, analyzing reciprocal relationships is a primary limitation. In reference to the dynamic elements in Phase 4, Andersen clearly states (in 1995 and again in 2008) that implementation of the model “requires more creative and challenging conceptualization, longitudinal and experimental study designs, and innovative types of statistical analysis” (Andersen, 1995, 2008). He looks to future generations to come up with creative, longitudinal study designs and innovative statistical methods to make full use of his model, and notes it would be worth the effort because the payoff is a better understanding of health services, thus a substantially improved ability to inform and influence important health policy (Andersen, 1995).

Fisher-Owens et al. also recognize the need to capture across-level interactions and feedbacks, understanding this is what makes health a dynamic, evolving system. There is specific mention of feedback loops or reciprocal causal forces that are part of causal relationships

expressed directly or indirectly. There is also acknowledgement of the complex interaction of factors influencing outcomes. Fisher-Owens illustrates the multiple levels of influence as nested and hierarchical, but provides less sense of the mechanisms of interaction or feedback. They acknowledge the most challenging issue with developing realistic conceptual models is causality and the resulting complex interplay of factors, such as those expressed directly or indirectly through reciprocal causal forces or feedback loops. Fisher-Owens registers concern with representing the functional form of causal relationships using commonly used statistical modeling that assume linear relationships, as few natural processes are truly linear. Though structural equation modeling can help project mediating effects, and multilevel modeling can help analyze data at different levels of influence, both of these add additional assumptions and implementation is complex.

Lee & Divaris (2014) also elaborate on a number of mediators and pathways theorized as influencing at the individual level, with many reciprocal relationships and feedbacks, particularly between oral health behaviors and service use. Unfortunately, they do not connect any of the health system and provider factors to these mediating factors.

Figure 6 outlines how hierarchically nested political, social, environmental, population and behavior, and biological factors interact with each other to generate health disparities. A feedback loop of oral health outcomes on these factors is also depicted.

In summary, while these three models all recognize the “dynamic” nature of oral health, feedbacks in the system, and complex interactions between and within levels of influence over time, they also acknowledge limitations in implementing these aspects of the models. As I will

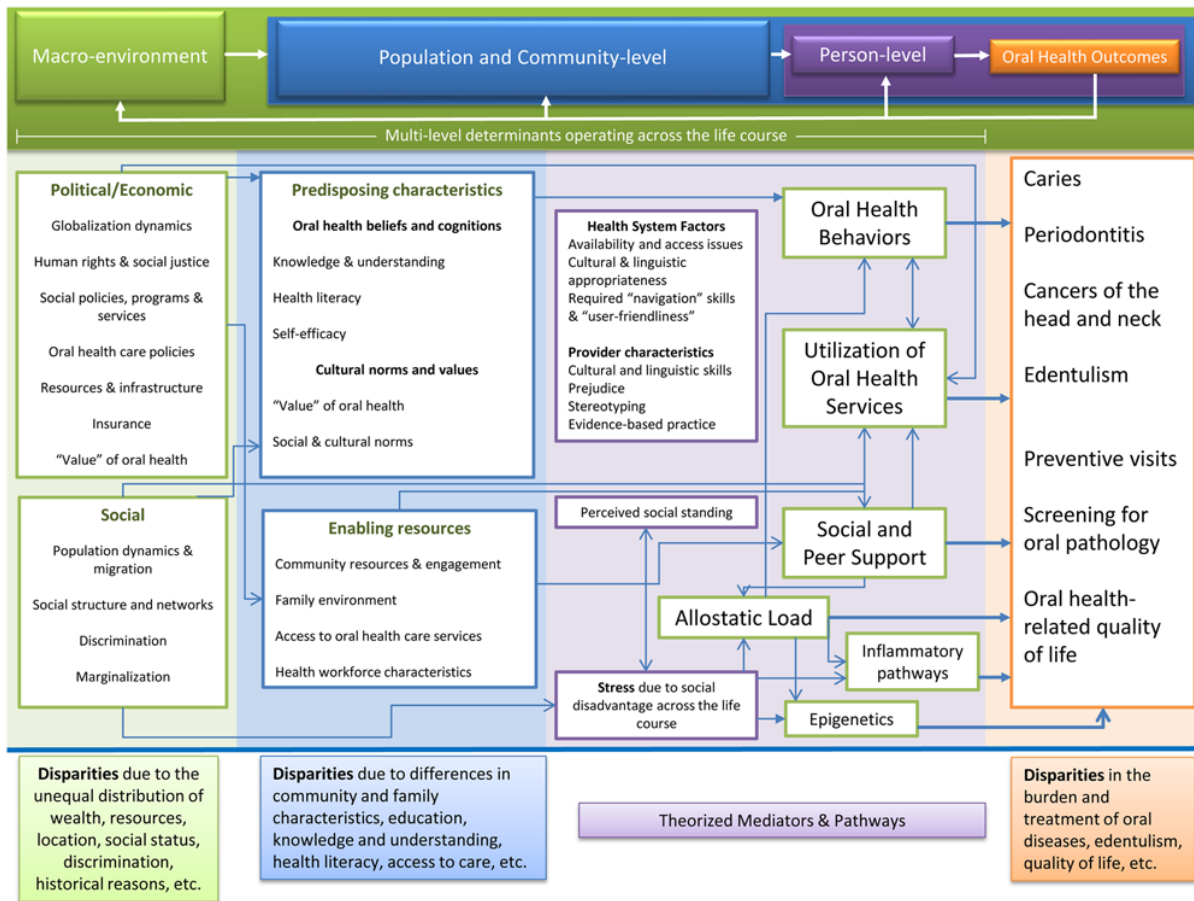

Figure 6. Lee & Divaris' proposed framework to conceptualize and act up on eliminating sources of oral-health disparities. (Lee & Divaris, 2014)

discuss later in more detail, complex systems methods such as agent-based models, systems dynamics and discrete event simulations are approaches that are well suited to study and provide insight into these types of dynamics.

Health Care System, Provider Behaviors, and Dental Care Process

The frameworks discussed thus far include health system characteristics as a context for an individual's use of care and experience of care, but acknowledge few factors that specifically influence individual provider behaviors and/or the patient-provider interaction.

Health system characteristics

In all of these models, health care system characteristics are represented at the macro or community levels, but there is little attention to provider-level factors. Fisher-Owens includes health care system characteristics at the community level, but not at the individual level. Lee & Divaris include health system factors and provider characteristics at the macro, population and community levels. These include oral health policies, insurance, and value of oral health at the macro level; access to oral health care services and workforce characteristics as enabling population-level factors. Community-level health system characteristics include availability and access issues, navigation skills, and user friendliness of the system. Provider characteristics include cultural and linguistic skills, prejudice and stereotyping, and, finally, what I consider very important as it relates to this project — whether they use “evidence-based practice.” Surprisingly however, the health system and provider characteristics box has no linkages or influences on individual-level factors including oral health behaviors, utilization of oral health services, or oral health outcomes.

Provider related influences

Phillips et al. (1998) noted about earlier iterations of the Andersen model that provider-related variables (patient factors that may be influenced by providers and provider characteristics that interact with patient characteristics to influence utilization) received little attention in the literature. She proposes that the lack of provider-related variables results from the fact that the model focuses on patient utilization, and that future research should examine the role of provider characteristics and provider-patient interactions. Finally, she offers that “it would be useful for more studies to examine both conceptually and statistically the contribution of environmental and provider-related variables to the understanding of utilization behavior” (Phillips et al., 1998).

Similarly, the theory around health care professionals' behavior and its possible influence on use of services has received little attention (Godin, Bélanger-Gravel, Eccles, & Grimshaw, 2008). Yet there is substantial evidence that health care providers, whether medical or dental, have an influential role either directly or indirectly on treatment, outcomes, compliance, and continuity of care. Thus, with an eye to both utilization of services and health outcomes, I suggest a more in-depth consideration of how the health care environment and specific provider characteristics influence provider behaviors at the patient-provider interaction, and concomitant outcomes for both patient and provider.

There is a substantial body of literature around healthcare provider behaviors. Some of it considers the influence of economic drivers in health systems that affect provider behaviors. In the last few decades, a focus on value in care has brought together concepts from organizational behavior, cognitive psychology, and social psychology to understand how to change and move organizations towards more effective and efficient patient-centered medical homes. Many of these concepts apply to dentists and dental homes as well. However, dentists are more often solo practitioners and do not tend to practice in large organizations; the focus is thus more on individual provider behaviors rather than organizational behavior.

Provider characteristics relative to patient characteristics

Several provider characteristics relative to their patients emerge as important predictors of dental use and treatment, and provide insight into why patients sometimes receive unequal treatment, potentially leading to observed disparities. These include power and information imbalances, social distance, racial discordance, and stereotyping of “outgroup” members.

Power and information imbalances

One of the seminal works around dental patient-provider interaction and dentist behaviors is Grembowski, Andersen, and Chen's paper published in 1989. They draw on the behavioral literature at the time and applied it to dentistry. They also offered a more comprehensive behavioral model explaining dental utilization from both the patient and provider perspective, adding insight into possible mechanisms through which provider characteristics and behaviors influence the care process and outcomes. They posit that because of the information imbalance between patients and providers regarding a patient's clinical oral health status (Reisine & Bailit, 1980) providers and the characteristics of their practices may have a substantial influence on dental use (Grembowski et al., 1989; Grembowski, Milgrom, & Fiset, 1988).

Research has found that dentists respond differently to patients based on their social class and racial/ethnic characteristics. To help explain differences in care between poor and non-poor and the nature of the patient-provider relations in the dental care process, Grembowski et al. (1989) framed the dental care process as a social exchange structured by the environment as well as by the patient and provider. Their model focused on power imbalances in the relationship and factors that might affect that imbalance, i.e., who depends most on whom? Many factors and dynamics they highlight have been repeatedly observed in more recent studies (Mertz & O'Neil, 2002; Milgrom et al., 1998; Mofidi, Rozier, & King, 2002). Several mechanisms mediated by the power balance were posited to have an effect on provider behavior, coming in response to patient characteristics.

Social distance and racial discordance

Nationally in the dental workforce, most dentists are white (74%), while Asians are overrepresented (15.8%), and blacks (4.3%) and Hispanics (5.3%) are severely underrepresented,

as are American Indians or Alaska Natives (ADA HPI, 2017c). Workforce diversity is a persistent problem, especially in dentistry (Mertz, Wides, Kottek, Calvo, & Gates, 2016). “Social discrimination” continues to emerge and impact the dental care process. Thus, racial and ethnic disparities exist not only at the patient level but also at the provider level (V. A. Lewis, Frazee, Fisher, Shortell, & Colla, 2017). Patient social and/or racial/ethnic characteristics affects how dentists respond to them, what and how much dentists communicate, the selection of treatments, and overall quality of care (D’Anna et al., 2018; Grembowski et al., 1989; Kressin, 2005).

Grembowski et al. suggest that the effect of social distance or racial discordance can affect the power balance, and thereby affect these other issues. In particular, they discuss how information is a form of control and power in the interaction. Research finds that lower-income individuals generally ask fewer questions in a clinical encounter. Doctors might perceive this as indicating less desire for information and, consequently, communication tends to decline in quantity and quality. The authors suggest this might partly explain why these patients have difficulty maintaining a regular pattern of preventive visits.

Treatment selection and the quality of care also vary with the characteristics of the patient (Grembowski et al., 1988). Kressin et al. (2005) documented racial disparities in rates of tooth extraction versus root canal therapy among insured patients in the Department of Veteran Affairs. They controlled for severity, age, sex, geographic region, other comorbidities, prior use of preventive dental services, tooth extraction, and root canal therapies. They found that blacks and Hispanic patients were less likely to receive root canal therapies to save the tooth than white and Asian patients were.

Stereotyping the “outgroup” as homogenous

Van Ryn and Fu (2003) suggests a possible etiology for these behaviors, drawing from a vast literature of cognitive and social psychologists’ work on how group characteristics influence perception and interactions. Physicians and dentists are no different from the rest of us in that they use categorization and stereotyping when making sense of other people, especially those different from them. By unknowingly applying these beliefs and expectations about categories of groups, we generalize them to all individuals categorized in that group. This is an adaptive process for simplifying massive amounts of information, especially when under time pressure or otherwise taxed. Like all of us, providers are more likely to rely on stereotypes for people “not like us.” We tend to view the “outgroup” members as homogenous, whereas the “ingroup” (those like us) are more likely seen as heterogeneous. This suggests that, for example, white providers are more likely to perceive Hispanic or black patients based on group stereotypes, and will be less attentive to their individual characteristics (Burgess, Fu, & Ryn, 2004). Unfortunately, because populations that experience the greatest health disparities tend to also suffer from negative cultural stereotypes, this kind of bias among providers can impact clinical decision-making in ways that can perpetuate health disparities (Institute of Medicine (US) & Committee on Understanding and Eliminating Racial and Ethnic Disparities in HealthCare, 2003). This highlights the importance of the patient-provider interaction and the influence it may have on treatment, trust, compliance with care, behavior change, and ultimately oral health outcomes and satisfaction with care.

Process of care – patient-provider interaction

The current study has a focus on the process of care and its outcomes, but specifically testing the effects of how the provider responds to a patient’s risk and disease status. It is, therefore,

pertinent to situate provider behaviors in the causal pathway by which it can influence patient outcomes, and better understand the influences driving provider characteristics and behaviors.

Influences on patient-provider interaction and outcomes

Provider care-delivery characteristics and decision-making affect the patient-provider interaction, patient decision-making, and patient health outcomes. If provider behaviors vary in ways that exacerbate structural inequities, addressing upstream factors leading to social determinants will not close the gap in health disparities. We must also look at drivers of provider behavior in their interactions with patients to complement the upstream efforts.

Andersen responds by including the second important addition: the process of medical care (or dental care) as health behaviors in the Phase 5 version of the model. This represents how the provider “interacts” with patients in the process of care delivery, for example with regards to patient education, ordering tests, and the quality of communication (Andersen, 2008; Andersen & Davidson, 2007). However, though the process of care was included in the Andersen model, and certain aspects in other conceptual frameworks, it has overall received less attention in the health services research literature related to access to care and oral health (or health) disparities. The addition of process of care within health behaviors suggests they are part of the same construct. Baker (2009) suggests, however, that personal health practices and use of services may instead be two separate, albeit interrelated, constructs and should be represented as such. I would add that the process of care should also be considered as a separate construct. Some 20 years later, implementation of these aspects of the model still tend to receive less attention than the individual predisposing and enabling characteristics.

Anderson rightly conceptualizes perceived need as a social phenomenon largely determined by social structure and health beliefs, and so adds “need” at both the contextual and individual

levels. Sarah Baker applied Andersen's behavioral model to oral health to understand the direct and mediated pathways from contextual factors shaping perceived oral health outcomes using path analysis. She found that some of the concepts are very broadly defined and are thus overlapping, which makes it difficult to operationalize. For example, income can be modeled as a predisposing factor, yet in some research it is modeled as an enabling resource. It likely acts as both, but analytically it is not possible to have an indicator that represents multiple latent constructs. Another example is whether clinician-evaluated oral health status (e.g., the number of decayed and filled teeth) should be incorporated in the model as an evaluated need or an objective oral health outcome, i.e., an endpoint (Baker, 2009).

Manice (2013) underscores the importance of subjective provider-patient care experiences, where communication is critical in enabling true or perceived opportunity for the patient to participate in decision-making. She conceptualizes this as a part of the process of care and in so doing further elucidates the feedback loop to true or perceived need. The literature supports the impact true or perceived opportunity to participate in decision-making can have on need, which subsequently drives utilization. She posits that perceived opportunity to participate in decision-making increases desire to comply with medication regimen and enhances understanding of disease severity. Driving patient and parent understanding of the true/perceived need ultimately drives use of services. Though applied to asthma control, this concept can be easily applied to dentistry and caries control.

Far from just conceptual, Manice's (2013) results revealed that greater opportunity for shared decision making (SDM) was associated with insurance coverage and lower mean ED visits (27% reduction). Lower odds of SDM opportunities were associated with minority race (black, Hispanic), as well as non-English speaking family, parents having less than high school

degree, as well as household income, functional status, presence of asthma symptoms, presence of comorbidities, and medication use.

Dentists' behaviors and use of evidence-based practices

Clinicians are expected to keep up with advancements in dental therapies, materials, research and clinical recommendations. There is a growing need to bridge the gap between research and clinical dental practices. Clinical guidelines/recommendations are useful to help clinicians cull through and translate the best evidence into practice (Dhar, 2016); professional guidelines are generally published by professional organizations and disseminated to their members.

However, evidence suggests that the release and publication of professional guidelines does little to impact adoption. Dentistry researchers from University College London examined systematic reviews of strategies for the dissemination and implementation of research findings and reported a number of factors related to individual practitioners' knowledge and education, their practice, the wider health system environment, and patient and social environment factors. They concluded that the passive dissemination of guidelines through the distribution of educational materials and clinical guidelines or attendance at didactic meetings have little effect; yet these methods are the most prevalent among dental educational programs. They suggest more interactive, participative, and multifaceted approaches are needed for greater long-term impact and sustainable changes in clinical practice (McGlone, Watt, & Sheiham, 2001; Watt et al., 2004).

In health services, the level of evidence with the highest regard is attributed to systematic reviews and meta-analyses, followed by randomized clinical trials (RCTs). After that, these follow in the hierarchy of evidence: non-RCTs, cohort studies, case-control studies, cross-over

studies, cross-sectional studies, case studies, and expert opinions (Ismail, Bader, ADA Council on Scientific Affairs and Division of Science, & Journal of the American Dental Association, 2004). This hierarchy is universally agreed upon as strongest to weakest. Paradoxically, dentists appear to most highly value evidence at the weakest end of the hierarchy —expert opinions, and almost above all, their own anecdotal experience.

Adoption of risk and disease management

Sbaraini et al. (2011) conducted a qualitative inquiry with dentists who participated in a randomized controlled trial of a standardized protocol for risk and disease management of caries. They noticed that implementation of the protocol was not consistent across practices. This led to a focus on how dentists incorporate evidence into practice. Their findings on how dentists understand and adopt evidence into practice indicate that dentists' concept of evidence is one that is "clinically demonstrable" in their practice, meaning they tried it and observed the effects. This would make the trialability and observability of the practice of paramount importance (Gurses et al., 2010; Kahan et al., 2014; Rogers, 1995). Trying it out allows adopters to reduce their uncertainty about the risks and benefits. Even when the weight of evidence argues for or against the benefits of adopting a technology, personal experience (one way or the other) can, in the reasoning of dental practitioners, outweigh the evidence. This most tangible of evidence had the highest value to private practitioners, followed by the experience of peers or research done in private practices. Some individuals deal with the uncertainty of an innovation by seeking information from peers. This ratifies what others have found over decades of research among physicians. Dentists reported lower trust in what they considered less tangible evidence, such as randomized control trials, academic lectures, or research from commercial manufacturers of dental products (Sbaraini, Carter & Evans, 2011). Van der Sanden et al. found in a survey of

Dutch dentists that the most important barrier to successful implementation of guidelines is the fear that guidelines will reduce their professional autonomy (van der Sanden et al., 2003), a concern frequently highlighted about dentists.

A dentist's belief about the effectiveness of caries risk assessment has been found to strongly predict the dentist's implementation of dental preventive behavior. Yokoyama (Yokoyama et al., 2016) found that among the Dental Practice Based Research Network in Japan, belief about the effectiveness of in-office caries risk assessment was strongly related to their recommendations for fluoride application at a visit and whether they practiced preventive dentistry. Thirty percent of dentists had a low outcome expectancy towards the effectiveness of caries risk assessment; 23% was reported from a similar cohort of U.S. dentists. The authors suggest, as do other authors in the literature, that these beliefs are related to "outcome expectation," the belief that performing a specific behavior (caries risk assessment) will lead to a desired outcome (dental caries prevention). They suggest continuing education as a way of increasing dentist's outcome expectancy. Confirming the findings of another study by Yokoyama (2013), the 2016 study found that dentists' rating of patient preference for preventive care was also strongly related to their preventive services. The direction of causation is not clear in this case, but the study points to potentially significant feedback between patient preferences and provider practices.

The power of habit

Another emerging concept from health practitioner behavior research is *habit* and its role in resistance to change. It is also based on 20 years of research neuroscience, psychology, marketing, and behavioral economics. Nilsen et al. (2012) highlight that while social cognitive theories of behavior change offer valuable insight into how behaviors are initiated, they have

failed to consider the critical role of habit in explaining how changes in clinical practice occur. Habits develop through repetition of behavior in the presence of cues. They suggest that the daily practices of health care professionals are predominantly habitual and therefore difficult to change through many conventional implementation interventions.

Nilsen (2012) suggests that social cognitive theories are limited in explaining behaviors that are more habitual and do not require contemplative decisional process. The context of the behavior formation can affect how it responds to change. It appears that in familiar and unvarying settings, behavior tends to be guided more by habit than intention, but in novel or changing contexts, behavior will be regulated by intention. And where habit and intention conflict, behavior is more likely to follow habit than intention (Gardner, 2015).

This would further explain why commonly used interventions in implementation research that include dissemination of printed educational materials, such as guideline recommendation and various forms of education, including continuing education programs, fail to translate to lasting, and often even temporary, behavior change. These approaches are based on the assumption that intention and thus behavior can be influenced by the provision of appropriate information about the behavior. But a growing body of research shows that habits can interfere with processing new information through several mechanisms:

- 1) Habits can reduce the likelihood of acting on new information and even cause one to avoid information that challenges the present behavior.
- 2) As behaviors become habitual, expectations of outcomes develop.
- 3) Expectations reduce awareness of new information, causing one to overlook alternatives; i.e., habits yield tunnel vision (Nilsen et al., 2012).

Experts have applied the concept of habit to professionals' intentions and clinical behaviors. Empirical findings in various fields suggest that behaviors repeated in constant contexts are

difficult to change (Nilsen et al., 2012). In light of all this, one must come to appreciate the adoption of guidelines in a dental practice may not follow a simple linear model of:

Knowledge → Attitude → Behavior

It may be a Sisyphean task that could benefit from additional tools and perspectives. The habit definitions include an “automaticity” dimension to the behavior consistent with dual processing modes of reasoning and information processing. Sladek et al. (2006) suggest that this model, which describes an automatic mode that is fast, intuitive, and heuristic, operating in parallel with an intentional mode that is rational, deliberate, slow, and rule-based, might help identify factors that influence the uptake of new evidence by physicians, and dentists.

Similarly, research in neuroscience, psychology, marketing, and behavioral economics in the last 20 years suggests that contrary to the traditional economic theory of rational choice, individuals do not contemplate or decide much of their behavior; instead, decisions are collective decisions, and influenced by customs, frames, and shared assumptions and values. This multilevel theory proposed by Zimmerman (2013) leads to structural approaches that operate at the social level. Power can influence the evolution of the customs that shape cognitive habits. This might lead us to consider how the customs of a profession are shaped and the training environment where shared values are engendered.

Kao reports other internal barriers that clinicians face that can also be interpreted in the light of the habit concept. These include practice inertia and lack of motivation to change; the need for behavioral adaptations among the staff that may be difficult in a small practice; the habit of practicing the way they were taught despite updates to the evidence base; and the temptation to provide more profitable procedures over an evidence-based approach that may be more conservative and have higher health benefits to the patient, but less profitable (Kao, 2006).

Summary of model limitation of models and proposed additions

In summary, the three conceptual frameworks discussed do indeed capture several constructs and dynamics that characterize complex systems: multiple levels of influence, reciprocal and interacting relationships, feedback loops and the cumulative effects of time. However, though conceptually these dynamics are highlighted by the authors about the models, they are not always graphically depicted, and few of their applications have captured or conveyed the complexity of the models.

Reviews of how these models have been used also suggest that there are limited clusters of factors that are generally used, usually to study associations and linear relationships between either macro-level systems or social structures and enabling and predisposing factors and their effect on use of care or health outcomes. The dynamic aspects represented in these frameworks have received limited attention in the literature because operationalizing them is challenging, and statistical methods are complex and often require assumptions that do not reflect the nature of the system relationships.

Babitsch et al. (Babitsch, Gohl, & von Lengerke, 2012) found that the version of the health behavior model that most comprehensively reflects the dynamic features (Figure 4 on page 100) was used only in one study, even though all but one of the studies was conducted after version 5 was published. Version 5 . They also found that none of the reviewed studies used complex statistical methods and conclude that the explanatory power of the results is limited to single indicators. In so doing, the results have not conveyed the complexity of the behavioral model; they identify a strong need for studies that apply the model and adequately investigate feedback and operationalize its complexity (Babitsch et al., 2012).

Aside from the complex dynamics represented, there are important health system and provider characteristics that are largely ignored in these models. These factors can influence provider behaviors and their use of evidence-based practices, both at the macro (professional culture, training) and micro level (individual behaviors). Furthermore, social, cognitive and behavioral science research provides some important insight into factors driving provider, and even patient, behaviors. Kahan et al. (2014) propose that key determinants affecting clinicians behaviors include system characteristics and clinician characteristics but also determinants related to the characteristics of guidelines or innovations itself and the ease of implementation. Beyond a conceptual model, these suggest a theory of causation and mechanisms for influencing behavior that goes beyond the contribution of the reviewed models to social structures that might emerge from the interactions at these various levels of influence.

To capture most of these additional health system and provider factors I revised the Andersen Health Behavior model, providing a more balanced conceptualization of how there are predisposing, enabling, and need variables influencing the individual's health behaviors and use of services, the provider's behaviors and practices, and the outcomes of their interaction. Furthermore, Figure 7 conceptually illustrates additional feedbacks and relationships I think should be considered when studying population oral health outcomes.

Bringing together some of the theory to bear on the matter of introducing a risk-based approach to caries disease management in dental clinics points to the need to consider multiple levels of influence on the provider and process of care with feedbacks to the health system context. assess this information. This new understanding of behavior change points to the need to

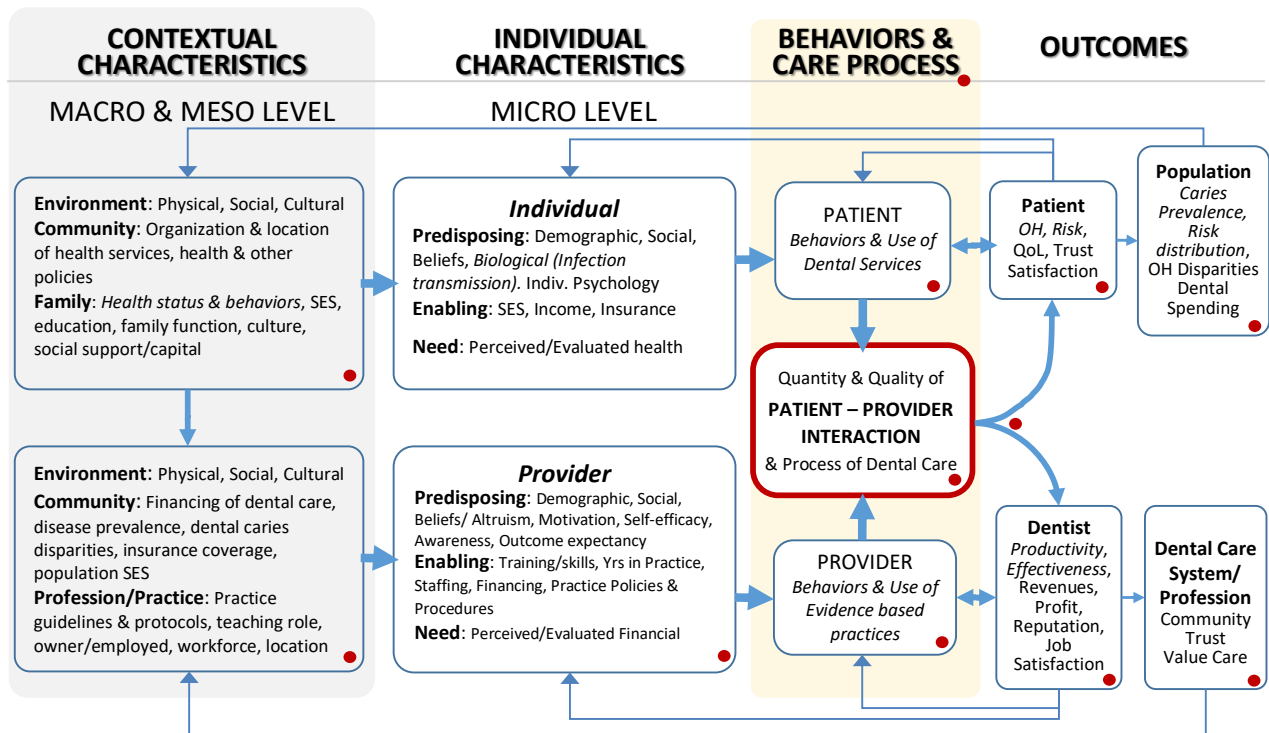

Figure 7. Adaptation and expansion of behavioral model of health service used to emphasize the influence of health system and provider factors on provider behaviors and process of care, and resulting outcomes for both providers and patient populations. Red Dots signify additions or modifications.

take a broader system view of resistance to change to create a supportive context and structure for change. The role of cognitive habits in determining the behaviors of professionals suggests the need to look upstream to where those habits are initiated and reinforced.

Reductionist vs. complex adaptive system thinking/systems theory

I have discussed various ways in which we have conceptualized health and oral health within the context of various social structures and population characteristics. In addition, faced with the challenges of representing multiple levels of influences, researchers often focus on the independent associations between factors. This is often referred to as a “reductionist” view of the system, one that does not account for the dynamic reciprocal nature of health care and relationships between patients and providers. This less effective approaches tends to focus on the individual, often suggesting simple direct relationships between knowledge and behavior typical of early health behavior change models (Kahan et al., 2014).

Turning to System Science to Capture Complexity

“The practice of dynamic systems modelling, as discussed herein, is the art and science of linking system structure to behavior for the purpose of changing structure to improve behavior. A useful computer model creates a knowledge repository and a virtual library for internally consistent exploration of alternative assumptions. Among the benefits of systems modelling are iterative practice, participatory potential and possibility thinking.” (Northridge & Metcalf, 2016)

System Thinking

System science offers both a way of thinking about the interconnected issues of population oral health and dental care as well as methods to study the more dynamic and complex aspects of these systems.

Donella Meadows defined a system as “an interconnected set of elements that is coherently organized in a way that achieves *something*” (Meadows, 2008). Systems thinking is the ability to see the interconnections as a way to achieve a desired purpose. All systems have a purpose, whether it is stated or not. The purpose often might not be the one we *want* the system to

achieve, or perhaps it is but we are just not willing to admit to it. Stroh (2015) suggests that one of the benefits of system thinking is to help people understand the purpose a system *is* accomplishing, which might be different from its intended or stated purpose. Stroh proposes that system thinking helps people see their responsibility in the system; if individual players can recognize how they unwittingly contribute to the problem at hand and understand their responsibility, they can start to change the part of the system they have control over — themselves. (Stroh, 2015).

He states that seeing this can prompt individuals to reflect on the difference between what they say they want (their espoused purpose) and what they are actually producing (the system's purpose). With regards to caries and dental care, this involves at least the policymakers, those who manage dental coverage programs, and dentists.

Meadows describes different leverage points in systems that can create the greatest amount of change (Meadows, 1999). She says that if you want to create change in a system, one of the least obvious things to look at is a system's *function or purpose*. Changing interconnections and relationships between a system's elements are important and usually results in changed system behavior. But "a change in purpose changes a system profoundly, even if every element and interconnection remains the same" (Meadows, 1999).

Meadows suggests the need to look beyond "the players to the rules of the game" because the rules of the game will better reflect the purpose. Though the purpose might not even be stated or expressed explicitly, it is often one of the strongest drivers of a system's behavior. The so-called elements of a system are usually the easiest parts to notice because they are often, but not always, visible, tangible things. Yet changing these usually has the least effect on the system. Even if all the elements of a system undergo a complete substitution, the system will generally

be the same as long as its interconnections and purpose remain intact. On the other hand, changing interconnections and relationships between a system's elements can greatly alter a system's behavior because it affects the flow of information leading to decisions and action points within the system.

What does this mean for dentistry and caries disease? How does this translate to the system of dental care delivery? First, it means that if we could replace all the dentists in the current system, we would still get a system that functions in a very similar way because the interconnections, the rules of the game, would not have changed. Rules like how and what dentists are paid for, standards for admission and training programs, the cost and requirements for degrees, and acceptance into the profession will continue to produce the same system behavior.

What if the dental profession had a goal more aligned with the goals of risk and disease management of caries — to preserve healthy tooth structure as much as possible, with a focus on prevention, remineralization, and minimal intervention? If this was the purpose that the profession itself embraced and believed, and federal, state and local policies also endorsed, and public health services supported, the flow of information would be signaling very different behaviors in the system, with possible impacts on disparities. If value is placed on these priorities, this would shape how dentists are trained and paid, eventually changing social norms for how dentists are accessed.

Workforce issues are a favorite go-to study area for dental access issues. If we addressed all these workforce shortages with new professionals to fill in the gaps that dentists leave as they respond to market forces, would we still have oral health disparities? Most of us would agree that this would solve only a part of the problem. Health *care* is only a small determinant of health. If

dental care cannot change the underlying behaviors that contribute to risk of disease development, it will have a limited ability to affect the incidence, prevalence, and resulting disease disparities in at risk populations. We may reduce the amount of untreated decay, but not the amount of decay.

According to Weber and Sodequist, systems thinking is a way to “learn smarter” by identifying high leverage points of change (Sodequist & Weber, 2016). System thinking is a new habit of mind and language. It is not just a matter of considering the broader system when decisions are being made; it entails understanding features of complex systems, some typical archetypes that embody these features (similar to change concepts in quality improvement), and learning to identify the dynamics. It would profit the public health professional to learn this new language because “if the systems underlying health behaviors are complex, then systems thinking must be central to how we intervene in those systems, whether the intervention is in policies, programs, or funding mechanisms” (Kahan et al., 2014, p. slide 257).

Policy resistance and bounded rationality

From a systems perspective, there are broader contextual influences on dentists’ behaviors that can affect guideline adoption. In the language of system science, this is referred to as “*fixes that fail*” or “*policy resistance*,” the tendency for interventions to be defeated by the system’s response to the intervention itself. Policy resistance is associated with the set of dynamics that help us understand a system’s response to new evidence, and can shed light on possible leverage points for intervention (see Table 2, above).

The problem of persistent disparities despite widespread efforts to provide dental care access, and of dentists not applying evidence into practice that could effectively help patients avoid disease, are examples of what complexity experts in system science call *policy resistance*

(Diez Roux, 2011; Sterman, 2006). It is an “inherent resistance of the establishment to allow changes to affect the system” (Meadows, 2008). This results in people preferring to live in a “flawed system” that is familiar, rather than to allow changes that have the risk of uncertainty and instability. Sterman warns that policy resistance can affect how we perceive our ability to change the world for the better; it breeds cynicism (Sterman, 2006).

Understanding the underlying dynamics of policy resistance can help us think about solutions that match the nature of the problem. Policy resistance suggests that important reinforcing and balancing mechanisms are likely involved and giving rise to inequalities. These types of mechanisms make systems persistently resilient to change. Understanding these mechanisms in a system can help us understand the causes of policy resistance and the “physics” of the system, which causes it to push back when you push it to change. *Behavior* is generated by *structure*; if we understand how our resources, organizations, and communities are structured, we can begin to change structures to allow for desired behaviors.

Much policy resistance comes from the *bounded rationality* of actors in a system, where actors have their own goals, often differing from each other. A term coined by Nobel Prize-winning economist Herbert Simon, bounded rationality is referred to as the “invisible foot” by World Bank economist Herman Daly (Meadows, 2008). Bounded rationality refers to the way people make very reasonable decisions based on the information they have. Yet no one has perfect information, especially about more distant parts of the system; how others in the system are behaving; or how the system as a whole responds to their decisions. Under this concept we are not omniscient, rational optimizers, but “blundering *satisficers* attempting to satisfy our needs”; we do our best to further our own interest but only taking into account what we know. Therefore, we do not foresee the impacts of our actions on the whole system, and instead find a

way to optimize our own situations, sticking to it until we are forced to change (Meadows, 2008). This concept resonates with how individual states implement financing policies for dental care programs that restrict spending, yet perpetuate the complex problems they are designed to address; or the practices of individual dentists whose decision to not accept certain patients, though rational from a business perspective, has important impacts on the welfare and oral health of the community they are dedicated to serving, and who are rarely informed about disparities in their local community.

Behavioral science, however, would hold that we often do not interpret information (albeit imperfect information) that we have. There are habits of mind we all have, protecting our mental models of the world; this means sometimes our decisions don't even optimize our own good, let alone the good of the system as a whole. These habits of mind include our tendency to overestimate the importance of recent experience and give less weight to past experience; we focus on current rather than long-term behavior. We also misperceive risk and discount the future; we do not let in information that does not fit our mental model. This concept of bounded rationality directly challenged Adam Smith's 200-year-old concept of economic theory in which *Homo economicus* acts with perfect optimality on complete information and the aggregate behavior adds up to the best possible outcome for all (Meadows, 2008).

It is important to understand this aspect of complex systems in order to uncover interventions or solutions that help change or improve the system. Being able to step back and have a whole system view can provide perspective; perspective to see feedbacks in the system, to understand the bounded rationality behind them, and think about ways to meet the goals of different participants in a way that also moves the system towards a more ideal state. Donella Meadows suggests that an effective way of dealing with policy resistance is to find a way of

aligning the various goals of subsystems by providing an overarching objective, allowing actors to break out of their bounded rationality to work towards the common goal.

System Science & Simulation Methods

Josh Epstein in his seminal article “*Why Model?*” discusses sixteen reasons to build models (Epstein, 2008). It might surprise some to not see “to predict” on the list. While prediction is possible with simulation models, usually a more important goal is to understand and explain. This reflects one of Richard Feynman’s famous quotes, “If I cannot create it, I do not understand,” which in system science has been adapted to “If you can build it, you can explain it.” Our ability to simulate a reality reflects our level of understanding of what creates that reality. Models force us to make our assumptions known and explicit. They expose our mental models. Explicit models are easier to test — both for internal consistency and external fidelity. Models can be useful when real-world experiments to inform policy choices are difficult, expensive, time consume, unethical, or impractical. They can uncover potentially unanticipated adaptive system responses a policy or intervention could trigger. They help us understand implication of heterogeneity across individuals, or contexts for the impact of a policy long term. Often the modeling process helps identify data gaps, and can therefore be used to guide data collection (Epstein, 2008; Hammond, 2015).

One of the misconceptions about models is that the purpose is solely to produce a model and results. Modeling is not just a means to an end; the modeling process itself is essential as it can generate critical insights about system structures and behavior that might not be obtained without the ability to inspect processes and interact with a simulation model in action.

Each method is particularly adept at capturing certain types of dynamics. Following is a brief introduction to each of the system science methods I will pilot as part of this dissertation: causal map diagrams, system dynamics, agent-based models and discrete event simulations. I will highlight their strengths and uses in the dental/oral health field.

System dynamics models

System dynamics (SD) is a methodology for understanding the behavior of any feedback-rich system. It involves mapping and then modeling the forces of change to better understand the influences so the overall direction of the system can be better governed (Homer & Hirsch, 2006; Milstein & Homer, 2006; Repenning & Sterman, 2001; Sterman, 2000, 2006)

It involves dividing the population into categories of states or “stocks,” mathematically representing how these accumulations interact with each other, and tracking how members of one move or “flow” to another category (El-Sayed & Galea, 2017). Key to the methodology is using these types of stocks and flows, discovering *feedback loops* in the system — they are at the heart of system dynamics — and understanding time delays. Feedback are actions that can reinforce or counteract (balance) each other. For example, X affects Y, and Y in turn affects X. One cannot predict the behavior of a system by simply studying the link between X and Y, and independently Y and X (Milstein & Homer, 2006). The feedbacks are important because they contribute to systems resisting change and for change to happen where we might not expect it. Seeing these causal feedbacks in systems gives us language to describe a vast array of interrelationships and deeper patterns of change that lie behind the events and details (Senge, 2006).

Because the complexity of our mental models vastly exceeds our capacity to understand the implications, we need computerize simulation (Milstein, 2006). Unlike time series models that

capture trends in observed events, or multivariate statistical models that clarify patterns of drivers or correlates of trends, SD models focus on the *causal structure*, out of which events and patterns emerge. With a focus on learning, SD models do not automatically exclude variables if measures are not available or imprecise, since to omit it for lack of precise measurement is equivalent to assigning it the one value we are most confident it does not have: zero (Forrester, 1980, in Milstein, 2006)).

System dynamics has a simplicity to it, making it a useful tool for involving stakeholders and policymakers in discussions leading to policy decisions. While limited in its ability to represent human interactions, SD's are computationally approachable and flexible and have demonstrated remarkable power in providing insights into the dynamics of both infectious and noninfectious diseases. What is particularly powerful about SD is that parameters like duration of infection and contact rates (representing different levels of crowding) can be changed interactively. SD is also amenable to describing more abstract concepts, like an amount of "self-efficacy."

It is the method most often applied to oral health and dentistry, as well as child oral health specifically. Levin et al. (1976) introduced a general theory of human service delivery based on interaction between service programs and its clients/patients, and negative feedbacks between them. In the era when the economics of dentistry was receiving much attention, the focus was on supply and demand constructs and dentist business, yet they also highlight the need to understand dynamics of health care delivery to understand why they might not work as intended, and how delivery directly link to oral health outcomes. Gary Hirsch, the author of the dental chapters in Levin et al. (1976), recently collaborated with Burt Edelstein at Columbia University to develop two system dynamics models simulating the effect of various interventions on early

childhood caries and costs, including fluoride varnish, intervening in white spot lesions, use of motivational interviewing, and comparing the effect of intervening early or just by risk (Edelstein, Hirsch, Frosh, & Kumar, 2015; Hirsch, Edelstein, Frosh, & Anselmo, 2012). A team working with (among other) Sara Metcalf, a systems engineer/geographer at the University of Buffalo Dept. of Geography and Mary Northridge New York University College of Dentistry, used systems dynamics to understand access to dental care for older adults. The system mapping and dynamics model enabled the team and stakeholders to build shared knowledge about the dynamics of access and to identify and consider options for future program implementation strategies.

Causal loop diagrams and system mapping

A systems approach begins with the development of a mental model, which delineates our beliefs about the network of causes and effects in system operations, along with the scope of the model (which variables are included and excluded) (Sterman, 2000). Causal Loop Diagrams (CLDs) are often the starting point for many types of simulation analysis projects, long used as an analytical tool for developing mental models for system dynamics models. They are also considered a very important part of the systems thinking toolkit.

CLDs help depict the basic causal mechanisms hypothesized to underlie a system's behavior over time, also enabling the identification of potential actions to modify the system to achieve desired goals. This is what makes them a powerful tool when working with stakeholders.

Illustrating our mental models require us to be very explicit about our underlying assumptions, and to incorporate feedbacks and dependencies (Diez Roux, 2011). Pictures help articulate dynamic hypotheses of a system arising from endogenous consequences of the feedback structure (Binder, Vox, Belyazid, & Haraldsson, 2004) because interactions are often difficult to

describe verbally (circular chains of cause and effect) (Sanches-Pereira & Gómez, 2015). A CLD consists of relevant factors, and the causal relationships between them use arrows (or links) with polarities, and delays where relevant. The polarities indicate the effect one factor has on another. The delay refers to how long it takes for an influence to happen.

While the target of the exercise can be represented as a factor or a variable, they can also be represented or conceptualized as a “stock” that increases or decreases. Thus, to convert a CLD into a quantitative SD model we have to first represent the stock as a stock-and-flow diagram, with causal links as factors affecting the stock’s “inflows” and “outflows”. We would now have what is called a structured causal loop diagram, an example of which I present later.

CLDs are an essential tool, used to:

- 1) capture the structure of a system,
- 2) provide an overview of loop configurations so as to analyze systemic development, and
- 3) highlight important feedback loops and possible leverage points for intervention (Binder et al., 2004 cited by Sanches-Pereira & Gómez, 2015) .

A model need not provide a full accounting of the system to be helpful. It can be sufficient to learn how certain posited interactions between features might contribute to the behavior of the real system, thus helping think through interaction. The modeling of a complex problem is best accomplished with a “parsimonious model” — one that has requisite complexity to offer insight to the problem being studied, while simultaneously being as simple as possible, allowing for parsing and understanding of various interactions and feedbacks in the system.

Agent-based models

Agent-Based Models (ABMs) capture the heterogeneity of individual agents, interactions between agents, and between agents and their context or environment, giving ABMs a distinct

advantage over other modeling methods. As such they can capture emergent phenomena, provide a natural, bottom-up description of a system, and are flexible (Bonabeau, 2002). The ability of ABMs to bridge individual and aggregate system levels is a very important one for this study given that oral health is dependent on individual behaviors, and that these might be affected by dentists responding to individual characteristics. The influence of important factors in human decision-making such as social norms, individual preferences, motivations for behaviors, and relationships are often left out of or are only roughly approximated in traditional system dynamics models, but can be easily incorporated into ABMs. Agent-based modeling is a particularly promising systems science approach to model complex interactions and processes such as adaptive behaviors, feedback loops, and contextual effects related to chronic health conditions (Yan Li, Lawley, Siscovick, Zhang, & Pagán, 2016)

Some models like the one use in this dissertation are indirect models, not explicitly aimed at considering policy choices. Their focus is understanding etiology, explaining relationships between system structure and individual behavior over time. However, these models do provide insight into the co-evolving relationships between individual and system-level aggregate behavior (Kaplan et al., 2017). Both levels are captured and reflected. Behaviors at the individual level can create aggregate level structures that can then constrain individual behaviors. Understanding these pathways acting cross levels of scale will have implications for policy choices, but without additional calibration would not be used to quantitatively inform policy choices directly (Hammond, 2015; Kaplan et al., 2017).

Agent-based models have had limited application in oral health or dental care historically, but more recently several teams have employed it:

- 1) A team studying how social networks and geographic information systems can be used to understand and influence patterns of communication and participation in the ElderSmile program for oral health services (Metcalf et al., 2013; Wang et al., 2016).
- 2) A group in Tehran developed a simulation of the effects of friendship networks on dental brushing behaviors in adolescents to evaluate and guide education approaches (Roudsari, Shariatpanahi, Ahmady, & Khoshnevisan, 2016; Sadeghipour, Khoshnevisan, Jafari, & Shariatpanahi, 2017)
- 3) A group at the University of Leeds, U.K., simulated the competing ecology of bacteria within dental plaque (Head, Marsh, & Devine, 2014).

See Appendix 1 for more examples of applications.

Discrete event simulations

As its name implies, discrete event simulations (DES) model a system as a process with a series of discrete events. Almost as old as system dynamics, DES has its origins in the field of operations research focusing on manufacturing, services, supply chain management, and logistics (Borshchev, 2013; Dagkakis & Heavey, 2016). This method has the greatest penetration in health service delivery organizations as it is well suited to assess efficiency of delivery systems, conduct health technology assessments, ask what-if questions related to patient flow, examine resource needs (in staffing or physical capacity), and design more effective systems based on complex relationships among different variables. It is also the least abstract of all the methods, allowing managers and planners to readily participate in their design and analysis. I was unable to find any examples of DES used in oral health or dentistry, aside from the trust hybrid model discussed below.

Hybrid models

Different system-science techniques are best suited to address different types and scales of problems and answer different types of questions; no one methodology offers a replacement for

the others. However, significant synergies can be secured by combining methodologies that exploit the competitive advantages of individual methods. Models that include a combination of two or more methodologies are referred to as hybrid models. Few models use more than one method, and in oral health more than two is almost nonexistent. Some of the above-mentioned models that incorporate SD or ABM with social networks might also be considered hybrid models.

One of the few published hybrid models in oral health came from my dissertation work. Through a collaboration with University of Saskatchewan faculty and students, and based on the conceptual work of this dissertation and initial model development, a hybrid agent-based/discrete event model with a focus on trust and oral health disparities was developed. The model was published as a chapter in a book highlighting the work of the Network on Inequality, Complexity, and Health (NICH), and their use of complex methods and simulation models in the study of health disparities (Kreuger et al., 2017). Our model depicted how a risk-based approach to preventing and managing caries could interact with and feed into constructs related to trust in the patient-dentist relationship, and thus care seeking behaviors, with impacts throughout the social network. It provides a good example of the types of interactions and feedbacks that can affect the care and oral health of low-income populations.

Other complementary methods

Other techniques are also used to complement the above methodologies. For example, social networks can be incorporated to characterize the network agent relationships and geographic distributions. Geographic information systems and maps can also be introduced at various levels to incorporate relationships with the environment and neighborhood and help stakeholders visualize movement and patterns.

Use of simulation modeling to solve health and healthcare problems

System-science methods are growing in their popularity and use in public health and health services research. As a whole, however, the health care sector has been very slow to embrace them. *Building a Better Delivery System* (Ravitz, Sapirstein, Pham, & Doyle, 2013; Reid, Compton, Grossman, & Fanjiang, 2005), a joint effort of the National Academy of Engineering (NAE) and IOM, was offered in response to the vision set forth in *Crossing the Quality Chasm*. The report identifies the critical role for system engineering tools, addresses the interrelated quality and productivity crises facing the health care system, and calls for federal support and participation by educators and others in supporting use of these tools. A 2006 issue of the *American Journal of Public Health* was dedicated to the topic of system thinking and complex systems. It included a review by Trochim et al. (2006) of the challenges adopting these approaches in public health. At the center of the concept map of challenges was the need to “Show Potential of System Approaches” — this is precisely what this dissertation intends to do.

Maglio et al. recently proposed three ways modeling and simulation could provide valuable insights into population health and improve decision-making. The first is by identifying unintended consequences of a program or policy; the second is by revealing the likely dynamics in the system and how the dynamics affect variables of interest over time; the third is by exposing the individual and combined effects of program or policies (Maglio, Sepulveda, & Mabry, 2014).

Modern computing power has made it possible to rehearse deeply complicated scenarios in a highly compressed time frame. This technology enables public health and health services planners to posit a system of casual processes and mimic the behavior of a system as it evolves. This allows the results of decisions to be shown under controlled conditions, rather than relying

only on observations in the messy and slow real world. The possibility of developing better health policies through simulation studies offers numerous advantages for public health work. As Sterman puts it,

Even the best conceptual models can only be tested and improved by relying on the learning feedback through the real world...This feedback is very slow and often rendered ineffective by dynamic complexity, time delays, inadequate and ambiguous feedback, poor reasoning skills, defensive reactions, and the costs of experimentation. In these circumstances, simulation becomes the only reliable way to test a hypothesis and evaluate the likely effects of policies (Sterman, 2000).

A Functional and Theoretical Framework of Caries Disease, Dental Care, and Population Health

This system science framework has guided the approach and methodology of this dissertation.

This project applies almost all of these methods in order to pilot the utility of causal map diagrams, systems dynamics, agent-based models, and discrete event simulation. My initial approach is to create a system map of the influences or drivers in the dental care delivery system. This includes an exploration into the influences on dentists' practices and use of prevention and risk-based disease management. The goal of the exercise is to identify broader system structures influencing behaviors, and discover possible leverage points to create the greatest change with the least expended effort. I will describe the process and results in the next chapters. This process led to the development of the analytic frameworks described below. The dynamic nature of these frameworks is reflected in various feedbacks it contains.

This project is particularly interested in the system structure that relates to patient-provider interaction, process of dental care, and patient and provider behaviors and outcomes. Focusing on the specific part of interest from the conceptual model presented earlier, I developed two

theoretical/analytic frameworks (Figure 8 and Figure 9) to illustrate the functional dynamics and relationships, and hypothesized pathways leading to population oral health.

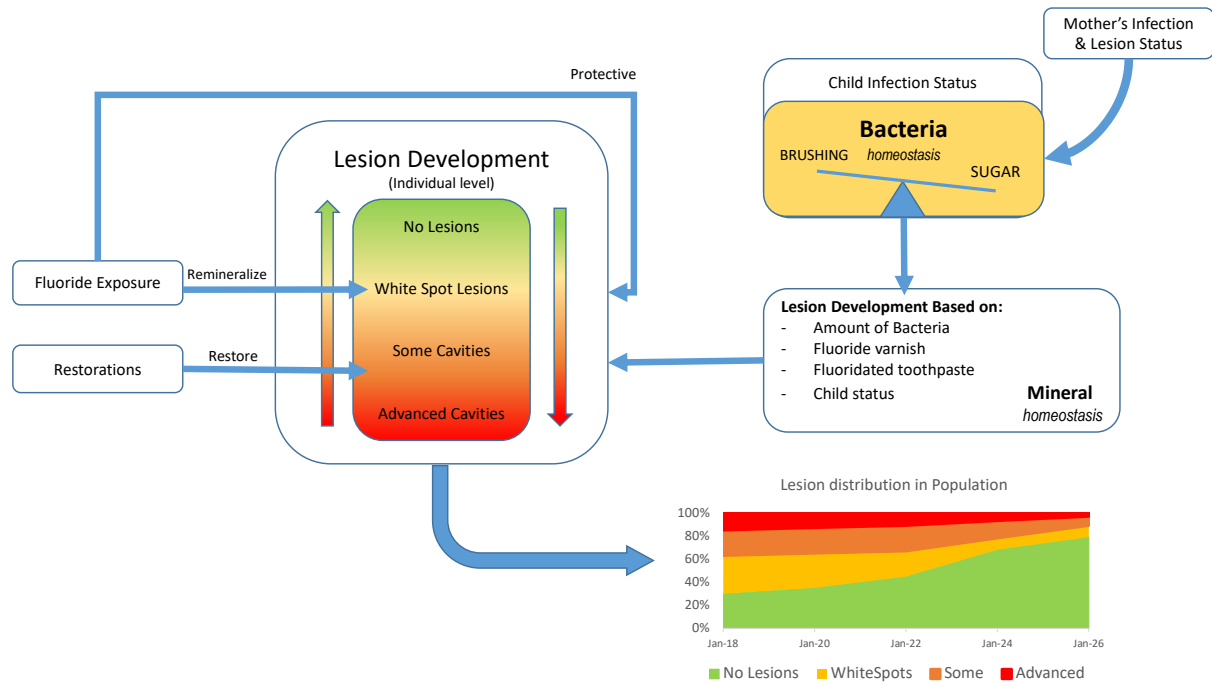

Figure 8. Agent oral health dynamics and lesion development.

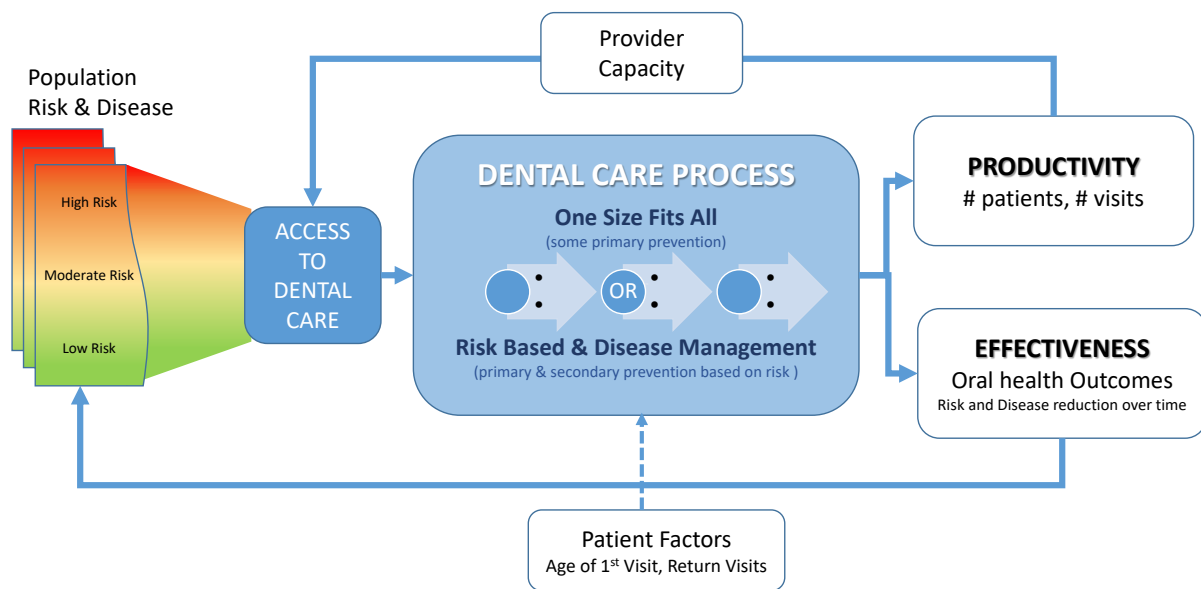

Figure 9. Feedbacks between population oral health, dental care process and approach, and provider and patient outcomes.

Figure 8 conceptualizes the factors and dynamics that contribute to the disease at the level of the individual and their mouth. The mother's infection status and level of decay affects a child's infection status. Once infected, the accumulation of bacteria is represented by a balancing mechanism of stocks and flows: the stock of bacteria grows and reproduces (sugar feeds it) or is removed (brushing removes some of it). Bacteria accumulates and forms plaque, which then contributes to demineralization of the teeth. The development of lesions is therefore influenced by the amount of bacteria, the protective effect of fluoride against the bacteria either through varnish (infrequent high concentrated), or toothpaste (frequent low concentration), and whether the agent is a child or adult. Fluoride can also be applied therapeutically to remineralize white spot lesions (left side of diagram). The enamel of primary teeth is thinner than that of permanent teeth leading to a potentially faster progression of caries.

Figure 9 depicts the patient and provider variables, and the feedbacks from and to the patient/provider interaction and across the individual and population levels. Populations with varying distributions of risk and lesions can access dental care at a dental clinic. Dental care can take on different approaches; a traditional one-size-fits-all, or one where risk is assessed and used for disease management. Based on the process, we observe productivity outcomes for the dentist and effectiveness of care outcomes for patients. These outcomes accumulate in the patient population and feed back into the presenting population. Likewise, the productivity of the provider feeds back to affect capacity and ability to provide access to care. The reasoning is that a more productive practice will have an enhanced capacity to see more patients, thereby increasing access to care for the population.

Just as dentistry may have been shaped by early demand for restoration, provider behaviors today can have an important role in shaping future social norms and beliefs about our ability to

prevent caries, and therefore when it is appropriate to seek dental care. I find that these interactions and feedbacks have received little attention, yet appear to be critical to the effectiveness of a risk-based disease management approach to change the course of caries in individuals as well as populations, and in turn to change care-seeking behaviors of patients. These things will not happen overnight, and the delays might make it difficult to observe or study changes at macros levels, hence another reason to draw on the strengths of complexity theory and system science methods.

Weber and Sodequist (2016) explain that adaptive learning is required to collectively problem solve around what they call *adaptive challenges*, also known as wicked or complex systems problems. These are intractable, messy, frustrating problems that persist despite genuine efforts of different parts of the system to correct them. The problem is that no one person or part of the system has the answer. It requires different perspectives that are shared, integrated and refined to reach effective solutions. But it also requires stakeholders to enter into an adaptive learning process, which might require them to change their own behaviors in order to create a solution. Kania and Kramer (2011) explain that collective impact is not merely encouraging or a matter of entering into more collaboration and public-private partnerships: “It requires a systemic approach to social impact that focuses on the relationships between organizations and the progress towards shared objectives.” The process of modeling a system, if appropriately harnessed and not overlooked as simply a means to an end, can lead to this type of adaptive learning. Models are tools for learning more quickly, more deeply, and more reliably, and using that learning to adapt behavior (particularly as supported by scenario evaluation with the model) (Osgood, 2018).

Causal Map — System Context for Oral Health and the Dental Delivery System

Why Take A Whole System View?

It is generally helpful to step back and take a broad scope view of a system's whole structure for finding effective solutions to dynamically complex problems. One of the reasons to do this with wicked problems that persist despite much effort directed towards eradicating them is because they are intrinsically systems problems. No one deliberately creates them, no one wants them, but they persist nonetheless. They are undesirable behaviors characteristic of the system structures that produce them. A corollary benefit of taking this perspective is that it helps avoid blaming and scapegoating, recognizing that if all the players in a system were all replaced with new people who were put in the same position, exposed to the same pressures and constraints, they too might behave in similar ways (Milstein, 2006). A system view helps us grapple with the fact that the cause of a problem might be “in here” rather than “out there” — something that psychologically and politically creates discomfort (Meadows, 2008).

Professional health care guidelines in concept support a system aimed at optimizing health, yet the practices of member professionals are not always in alignment with the recommendations, in large part because financing structures that often drive these practices are misaligned. Many of the efforts to improve population oral health fall short the goal because they often are made in piecemeal fashion and do not consider the full scope of the problem, including the interests of important stakeholders. Heirich (1998) “contends that successful reform policies must come from seeing the entire health care system as a large dynamic enterprise, complex unto itself and linked to changes occurring in the political economy of communities, the nation and the world” (Hirsch, Homer, McDonnell, & Milstein, 2005). It is also important to understand the forces that bring a health care system to its current state.

Part of the challenge of addressing the system as a whole is that it is not “one system.” It is fragmented by professions, political boundaries, administrative bodies, financing streams and incentives, and parts of the human body. Interest in the oral health of a population lies in two sectors: service delivery and public health. The service delivery is generally unequally split across private dentists (the majority) and community or federally qualified health centers. Public health departments are generally focused on the oral health of the population and access to dental care services. These departments are often the provider for disadvantaged populations, filling service provision gaps left by the service delivery.

While the effects of not intervening early with available preventive techniques may seem less important than ensuring business and professional viability, early intervention might actually be at the root of the causes and therefore also the solutions to the challenges faced by the profession (maintaining a sustaining clientele) and by public health (ensuring access to care for populations most vulnerable to the disease and its consequences). Improving the quality and productivity of dental care might seem more of a luxury that busy dental practices cannot afford; pursuing increases to Medicaid dental reimbursement rates might appear to be a simpler, more direct way to increase provider participation in Medicaid and therefore improve access to care for low-income children. However, this may be a shortsighted and limited approach that fails to appreciate the important relationships and dynamics of the system, which would not be changed.

The complexity of health and health care delivery systems poses a challenge for effecting changes that will stick. Among other things, the interdependence of elements means that while one part changes, other parts of the system maintain inertia to function as they were, often causing successful improvements to reverse, erode, and fail to sustain over time.

Most would agree that the goal of health care and public health is to enhance the quality of life of patients (health care) and populations (public health). However, the perverse incentive Ube Reinhardt alludes to is that patients “are both objects of human compassion and biological structures yielding cash flows,” and every dollar spent on care also represents someone’s income (Reinhardt, 2012). Dentists are concerned with providing care and the viability of their business, little of which concerns itself with the state of the population or community it serves; public health departments are concerned with promoting healthy behavior and ensuring that everyone can access care, but outside of country/locally run clinics they have little control or influence over the service delivery sector. Dentists want higher reimbursements for their services; they have accrued significant debt to undergo their training, so they now expect to earn incomes commensurate with their debt. But states and counties are trying to manage funds, so they limit either what they will pay for, how much, or both.

Evidence suggests that improving risk and disease management has the potential to achieve some though perhaps not all of these goals. Reducing the incidence and severity of disease can reduce the need for services dentists are paid to provide. Though slowing down the pipeline of patients maybe not be a value proposition for dentists it would be for the payers and patients. It is not clear how reimbursement rates might be affected, given that health care generally does not respond like other markets.

Chapter 3 Summary

In this chapter I introduce the features of the complex systems, such as the interaction of heterogeneous agents, that characterized by feedbacks in the system, resulting in nonlinear behavior and the emergence of often unanticipated system behavior. I discuss the relevance of

these concepts for how we think about and study complex systems such as population health and dental care delivery systems. As a way of introducing some of the dynamic features of complex systems I review three often used conceptual models of dental care and oral health to highlight features familiar to many researchers, and discuss how they are rarely a focus of study given the limitations of our methods. I also highlight the need to more fully represent the contributions of the health care system and provider characteristics and behaviors to the patient-provider interaction and dental care process in order to more fully understand those interactions, feedbacks and resulting system structures. This sets the stage to show how system science methods that are especially well suited to study feedbacks, interactions, time delays, across varying levels of influence among other things. A review of these methods (System dynamics, causal loop diagrams, agent-based models, discrete event simulations and hybrid models) and how they have been used to study issues in dentistry or oral health follows. This leads to the introduction of a dynamic and functional analytic framework of caries disease, dental care and population oral health.

Chapter 4: Methodology

Research Design

The research design for this dissertation has two parts: first a qualitative exploration using a causal loop diagram or system mapping approach, and second is a hybrid simulation model that includes an agent-based model (ABM) with a Systems Dynamics (SD) submodel and a discrete event simulation (DES). The hybrid simulation models caries disease and use of a risk and disease management approach to dental care, compared to a traditional one-size-fits-all approach. The model allows the representation of feedbacks and interactions between the dental care modality and population oral health, through its effect on practice productivity and effectiveness of care. These dynamics may influence the effectiveness of the new approach and help us understand how implementation factors might influence outcomes at the dentist and population levels.

Causal Loop Diagrams or System Maps of Influences on Dentists' Practice Behaviors and Caries Disease

Causal mapping is a technique to help examine the structural dynamics that govern health problems. Causal loop diagrams aid in synthesizing issues and identifying the relationships among these issues. The process of creating and analyzing these diagrams can make it possible to identify high leverage drivers with system-wide influence. They can then be used by stakeholder and systems practitioners to communicate and contrast the hypothesized understanding of the

system's structure driving the problem, and simplify operational objectives for health action while at the same time aligning the efforts of diverse stakeholders (Milstein, 2006).

One of the aims in developing a system map is to better understand the connection between structure and behavior. Understanding feedbacks is critical to the practice of systems thinking because they show how actions can reinforce or counteract (balance) each other.

Each causal link is assigned a polarity, either positive (+) or negative (-). A positive link means that all else equal, if X increases (or decreases), then Y will increase (or decrease) above (below) what it would have been. A negative link describes an inverse relationship where more of X results in less of Y. There are two types of feedback loops underpinning a system's behavior:

- Reinforcing Loop — is one in which an action produces a result that influences more of the same action, thus resulting in accelerating growth or decline (Bellinger, 2004). A reinforcing loop results when all links in loop are positive or there is an even number of negative links (irrespective of the number of negative links). Reinforcing loops can be:
 - Positive reinforcing loops, producing virtuous cycles. If directed in an adverse direction,
 - Negative reinforcing loops produce vicious cycles.
- Balancing Loop — a stabilizing, goal-seeking, regulating loop where the balancing feedback opposes whatever direction of change is imposed on a system. It tries to keep things in balance, or in a certain state, much like a thermostat does for room temperature. These feedbacks are both sources of stability and resistance in a system.

The power of this type of diagram is in the stories it helps to tell, assisting in making explicit our assumptions about system and individual's behaviors. This process takes perspectives or hypotheses, even heuristics, out of one's head and brings them into the light of day where through dialectical exchange between stakeholders, perspectives can be compared, critiqued, refined and combined with other hypotheses thereby improving the system map. Where stakeholders are not involved, as in this instance, its utility is in helping to identify feedbacks in the system, and perhaps identify important leverage points, using it to articulate the stories it

tells, to then share it with stakeholders. As a demonstration of the utility and feasibility of the approach, it is in creating the map that one can acquire and understand the technical nuances and utility of the method, in translating concepts into causal structures.

Developing the causal loop diagrams

The purpose of the causal loop diagram was to:

- 1) describe the feedback relationships and influences that might be driving dentists' practice decisions, and
- 2) think through possible pathways affecting whether dentists embrace and adopt new evidence and best practices around risk and disease management of caries,
- 3) determine how practices affect the progression of disease in populations, and
- 4) identify leverage points within and outside of dentistry that might help move the system in the direction of value care — better care, lower cost, resulting in better population health.

Drawing causal maps can be conducted with a number of software tools; I used Vensim PLE for Windows Version 7.1, a free learning edition and part of the Ventana Simulation suite. Vensim facilitates the design and implementation of systems dynamics models, both the qualitative and quantitative aspects. Vensim has features that help in drawing the diagram to conform to generally accepted standards for systems dynamics.

Generally this is an exercise best accomplished by a team of stakeholders providing multiple perspectives on the problem (Hovmand, 2014). However, in this dissertation, I applied the theoretical knowledge of systems thinking to the problem of dental care, and instead present the set of diagrams as a first pass at a system map that can be used as a starting point to present to stakeholders. In lieu of a team, I drew on the work of several experts and leaders in the field of system thinking and dynamic: Hirsch, Homer, McDonnell, and Milstein (Hirsch et al., 2005). They developed a series of causal loop diagrams to understand the health care system as a whole to describe and provide the historical context for four categories of reform initiatives: access,

cost, quality, and health protection. The group built this prior to constructing a system dynamic model, which they later used to analyze five policy proposals (Milstein, Homer, & Hirsch, 2010). Their example provided a useful template for how to think through and communicate the multiple factors and dynamics influencing caries progression and provider practices, especially because it considered risk and disease management as a strategy to approach disease progression.

I started with a stock and flow model to represent the progression of caries disease, similar to what Milstein et al (2010) used as well as other authors, to represent progression of chronic diseases, then considered the types of factors Milstein et al. included and considered if they applied to dentistry in a similar way (several did not), and finally considered other issues more particular to dentistry.

Hybrid Simulation Modelling

A simulation model lets us do things that are difficult to do in the real world, either because of logistics, ethics, privacy, or because of the time and resources such an undertaking would require. There is a paucity of information about the specific practices of dentists and the effectiveness of them. One reason is the difficulty in capturing the data; the lack of diagnostic codes makes it challenging to assess whether a procedure improved a condition and health status, as well as the magnitude of a problem across a patient population. The slow adoption of caries risk assessment and any type of documentation of risk make it difficult to characterize population risk. The private character of dentistry in general, and the fact that a large proportion of dentists are solo practitioners, makes it difficult to observe specific processes used in practice and affects dentists' willingness to take the time to share that information. Therefore the context for

implementation of changes to practice is fairly uncertain, and many assumptions need to be made.

Research Procedures (Modeling Process)

The procedures for this research involves the use of a computer and a simulation model. However, just as important as the final model is the development process. The modeling process involves several, often iterative, steps generally encompassing the model development and implementation of simulations. Figure 10 illustrates the cycle of modelling and simulation.

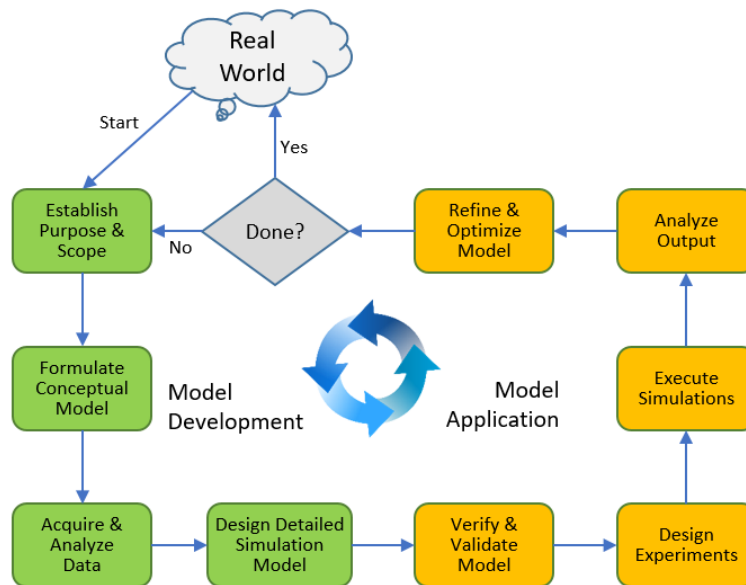

Figure 10. Modeling and simulation process (adapted from Benjamin, Patki, & Mayer, 2006 and Loper, 2015)

Figure 10 shows the basic ideas and steps through which simulation models are developed. Every model begins with an observation of the real world and defining the problem and the purpose and scope of the particular model. This leads to the next phase, which involves system

conceptualization and deciding on the level of abstraction, structure and logic of the model, including assumptions about parameters. After one acquires and distills down data to inform the model, the conceptual model is translated into a simulation structure using a programming language. At this point, we examine how the model behaves over time, whether it behaves as intended and whether the results of the model reflect the real-world phenomena being modeled. Since models often involve stochasticity, observing model response to parameter variation helps one understand which variables are the most influential in the model, as well as to give confidence in our understanding of the model and its assumptions. Verification and valuation are ongoing processes, and in some cases might be limited by the level of abstraction of the model and the existence of real-world data to compare with the model output.

Once the model is developed, we conduct experiments sensitivity analysis with scenarios to check sensitivity of the model to parameter variations. The design of these experiments must be considered during the conceptualization phase, as it will determine the level of detail needed in the model. This step also includes deciding the length of runs, the number of runs and the initial conditions for each simulation. The model is ran, tested, and observed. Output is generated and analyzed and conclusions drawn about the model, reflecting on what the results tell us about the functioning of this system that can inform alternative policies and practices and approaches for engaging the system under consideration.

In the following sections of this chapter, I will describe the modeling and simulation process for the caries and dental clinic model. As shown in Figure 10, this is an iterative process, often involving increasing levels of complexity being added to the model. An incremental approach to model development is the recommended approach. It allows for learning along the way about the role of different variables and the stochastic nature of the model. At each step one can

understand behavior patterns and interactions that emerge before adding additional features in newer versions. This can provide insights that inform further model development. It is rare to find this aspect of the model process documented in any publications on simulation models; when space is at a premium, usually only the final model is presented. Therefore, few examples are provided in the literature of the “modelling” process. I aim to be transparent about the developmental stages and iterative process of building and operationalizing the conceptual framework into a simulation model, and the decisions that were made along the way. However, given the nature of the collaboration with the programmers and modeler who assisted in the development of this model and time being at a premium, there was often limited time to observe the incremental model-building process.

Purpose and Scope

The first step is to establish the purpose and scope of the model. Defining the scope was perhaps the most challenging for me. Investing in the steep learning curve to develop a model, I wanted the resulting model to be able to answer a whole series of questions, and to have all the elements that would allow it to do that. In so doing, it slowed down the process, made it difficult to define the boundaries of the model, and increased the requirement for detail in order to allow different scenarios to be simulated. This rendered the first iterations very complex and less nimble, increased the need for technical assistance from outside modelers, and hindered my ability to understand model functioning, observe output, and learn from the iterative process. The experience confirmed the importance of this step.

Osgood often compares models to maps. Like maps, models represent abstractions of the world around us, which allows us to simplify or omit certain details, making them more feasible and possibly useful. Like maps, models are designed for a specific purpose.

“Simulation models depict dynamic hypotheses regarding the causal structure of a system.” (Osgood, 2014). It is helpful to characterize the structure and specific pathways as well as the connectivity between the pathways across the system as a whole. Stepping back and defining the specific purpose of the model and scope helps us make decisions regarding what should and should not be included in the model.

The purpose of the hybrid agent-based discrete event simulation model is two-fold:

- 1) Simulate the development of caries disease in children.
- 2) Simulate the two different approaches to dental care delivery and its interaction with patients and the disease process.

This chapter includes:

- 1) A description of the agent-based model (ABM).
- 2) A description of the systems dynamics model.
- 3) A description of the discrete event simulation (DES).
- 4) A description of how they work together in a hybrid simulation model.
- 5) Several kinds of analysis of what the framework is set up to do.
- 6) The set-up of scenarios for sensitivity analyses.

I will describe how I operationalized various risk and protective factors in the ABM model, including bacterial infection, exposure to fluoride, tooth brushing and sugar, lesion development and risk levels. I will use the “O! PARTIES” approach to describe the outputs, parameters, actions, rules, time, interventions, environment, and state of the model (Osgood, 2013).

Problem Conceptualization

Formulating a conceptual representation of the problem, as I understand it. This includes acquiring data and analyzing descriptions of the system, operationalizing processes, determining object roles, defining boundaries, the level of abstraction or detail to be included, determining the model structure and logic — if it relates to framing the problem, it needs to be thought about and defined. This is the first step in mapping the real world to a software model, and is more of an art than a science.

The conceptual design for this multilevel simulation model involves dynamics of a few “subsystems” that comprise what one might loosely refer to as the oral health “system”, and the interaction between them:

- 1) Disease progression in individuals and the resulting oral health of the population.
- 2) The dental care process and dentists’ practices.
- 3) Changes in health behaviors and/or health status because of the interaction between patient and dentist.

Figure 11 depicts macro relationships the model will simulate: how the risk and disease of a population can affect the operations of a dental clinic, including its approach to the care of the disease and productivity, and vice versa. One of the objectives of this dissertation is to study and highlight the feedback between these two aspects, denoted by the reciprocal nature of the relationship through time.



Figure 11. Relationship between population oral health and dental clinic operations.

However, the actual interactions that can result in changes in health status for a patient happen between an individual and their dentist and team. Complexity arises when there is variation in the characteristics and health states of individuals, interacting with the practices of the dentist in response to them. Figure 12 shows relationships at the individual (micro) level.

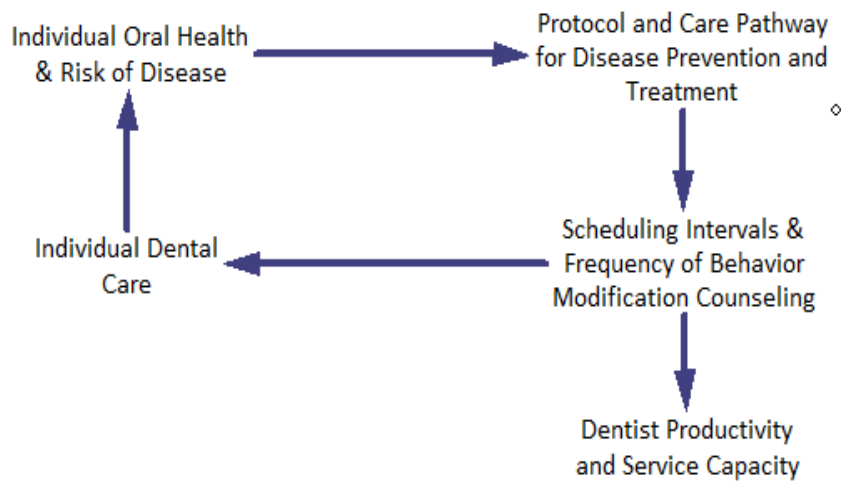

Figure 12. Micro-level relationship between individual risk and disease and dental clinic protocol and care pathways.

Each dentist has a protocol for how they practice and respond to the health and characteristics of each patient. This will determine at what point they will treat a lesion, and the level of education and counseling given to the patient.

Caries disease progression in individuals and populations

The initial step in understanding and conceptualizing the development of disease in a population is to capture how disease develops in individuals. The framework for this section of the model represents the natural history of caries disease. Caries disease is an infectious and chronic disease often resulting in cavities, so the model needs to capture aspects of disease progression; this is a key reason why I covered in great detail the history of the disease and its progression in an individual; it was essential for me to fully comprehend this in order to build an accurate model.

For purposes of this study, we have conceptualized the stages illustrated in Figure 13: no lesions, white spot lesions, some cavities, and severe cavities. Someone with no lesions can have varying levels of biological or behavioral risks.

Edelstein and Hirsch have presented two system dynamics models that capture similar aspects of the disease progression in Hirsch et al. (2012) and Edelstein et al. (2015). They differentiate treated, untreated, and symptomatic caries. Restorative treatment addresses acute consequences of the disease, cavities, but the disease is still present and chronic. At earlier stages of the disease or before symptoms can be detected, risks are present.

Since the purpose of this research is to compare a risk-based approach to care to a care model that does not account for risk, conceptualizing “risk” of caries is also an important aspect to model. Because of the multifactorial nature of this disease, it is often difficult to isolate the differential effect of single factors, many of which interact with each other. For this, I turned to the literature to understand the multiple factors that influence progression among the stages represented in Figure 13.

We know the presence of cariogenic bacteria is critical to the demineralization process that results in cavities. This cariogenic bacteria is not native to all individuals; it is often acquired through contact with an infected agent, usually the mother or main caretaker. The bacterial level and resulting oral health of this person will affect the likelihood of the child acquiring the

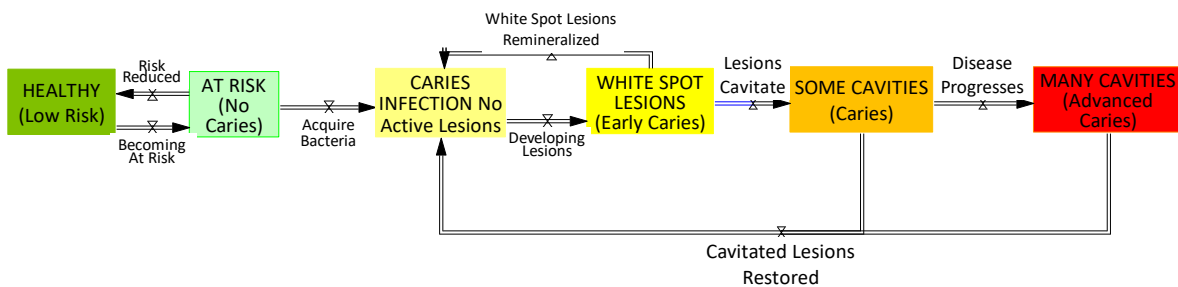

Figure 13. Stages of caries development.

cariogenic bacterial and is associated with the level of disease in the child. Though necessary for the disease, the presence of cariogenic bacteria is not sufficient for disease progression. The environment within which bacteria exists will determine whether they grow and accumulate, and this will determine if the disease progresses. Figure 14 is the conceptualization of the various factors that influence the growth and accumulation of caries-causing bacteria that lead to lesion development, and how different aspects of dental care can impact the disease process.

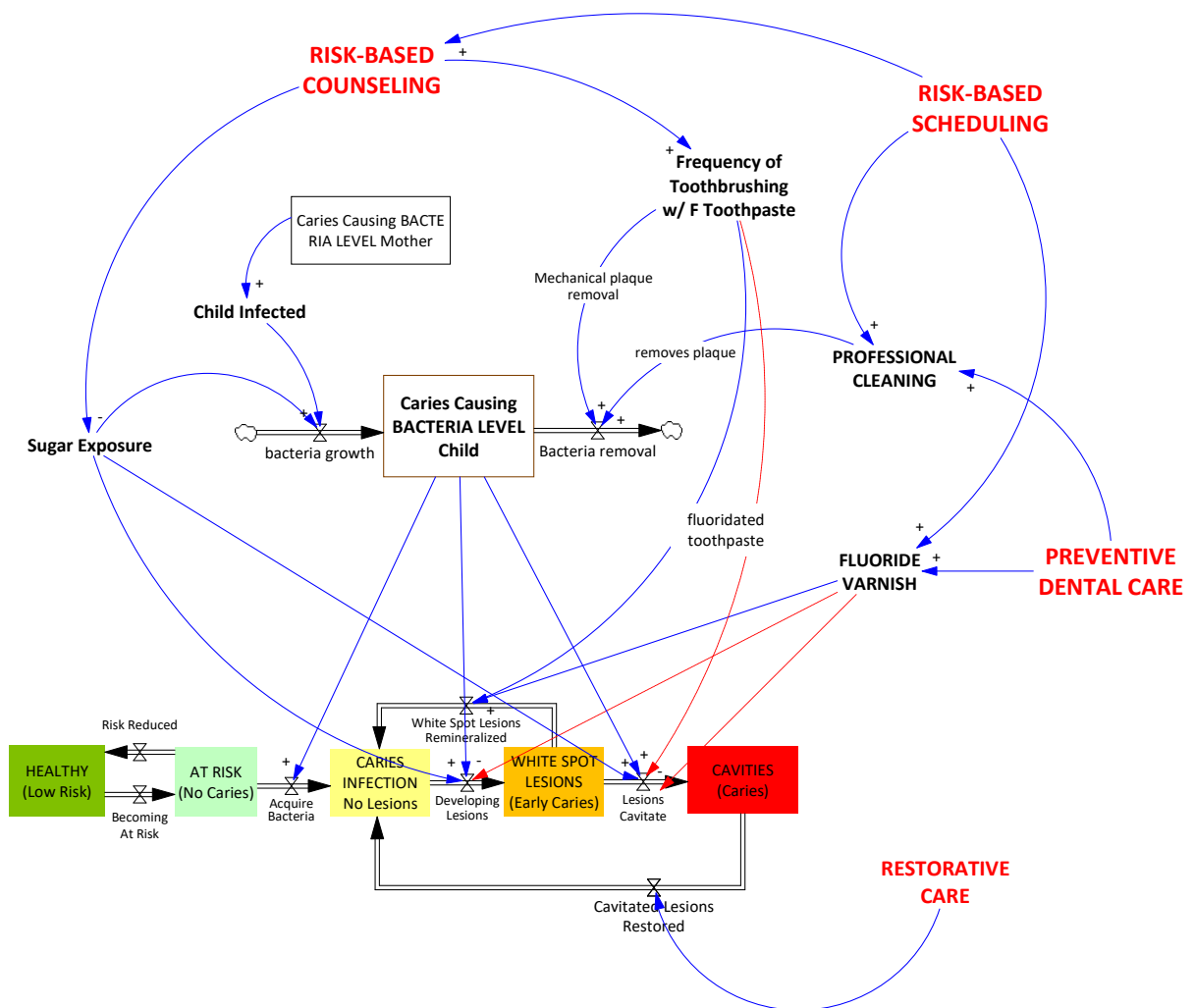

Figure 14. Influences of different aspects of dental care on caries disease process development

A dynamic process is present in the mouth that involves two main processes, a buildup and elimination of bacteria, and a constant cycle of mineralization and demineralization over the course of a day. The overall balance between the amount of toothbrushing and fluoride and sugar in the mouth will determine how the bacteria accumulates and its effect on the tooth enamel. Therefore, the frequency of tooth brushing and consumption of sugar-containing foods, especially in between meals, are important considerations represented in the model.

The dental care process and its interaction with patients

Operationalizing a risk-based approach entails considering the care delivery process at a dental clinic, how this may vary based on a patient's characteristics and the behaviors, or the characteristics and practices of the provider. Because the purpose here is to compare two different care modalities, identifying the key aspects that differentiate clinic pathways is an important step in conceptualizing the problem. Thus, two care pathways were defined: one for the traditional approach and one for the risk-based approach.

These are the principal ways the risk-based approach differs from what is traditionally practiced in dentistry:

- 1) Caries risk assessment is conducted at comprehensive and periodic exams
- 2) Behavioral counseling based on risk that would include the use of motivational interviewing and self-management goal-setting to manage risky behaviors and add protective ones.
- 3) Treatment plan includes a protocol for treating white spot lesion with topical fluoride.
- 4) Recommended intervals for return visits will be shorter for high-risk patients (e.g., three months) to receive added fluoride protection or treatment for WSLs and disease management counseling, and longer intervals for low-risk patients (e.g., 12 months). Intervals for moderate risk at six months; can be similar to the traditional approach.

Figure 15 represents how the clinic workflow and decision logic was conceptualized for each of the care modalities. Taken together, Figure 14 and Figure 15 show how dental care can intervene in the caries disease process:

- Basic preventive and restorative dental care provides cleanings that reduce the amount of bacteria present in the mouth and restores cavities.
- Risk-based dental care will do the above but also treat white spot lesions with the goal of remineralizing them and rendering them inactive.
- Risk-based counseling uses motivational interviewing techniques to activate patients and caregivers towards self-management of risk behaviors. A focus of this counseling is reducing exposure to sugar by addressing food habits and increasing exposure to fluoride through use of fluoridated toothpaste and water.
- Risk-based scheduling has a more global effect by implementing tiered exposure to needed care so that the frequency of fluoride applications and behavioral counseling are higher for those at high risk and lower for those at low risk.

Acquiring Data for Model Inputs and Outputs

A key challenge is obtaining reliable data on health behaviors at an individual level, and in the form that is needed to inform the model. Most data are reported as group averages. Some studies reported survival curves based on different characteristics, which gives an indication of those particular characteristics or behaviors. But it becomes more complex when trying to obtain data regarding combinations of characteristics, and how they interact with each other. Given the difficulty in obtaining specific individual-level data to inform parameters, in this first iteration of the simulation model, at times I used placeholders, or relative values, that would allow the model to run, and to see the behavior of the model in relative terms, even though not specific terms. The next steps in the model development is to better define those parameters.

The literature provides information of population distributions of behaviors that help calibrate the initial state of the model. Other data can help calibrate the model with regards to the outputs. Is what we are seeing coming out of the model similar to what we would see in the real world? Does it have any face validity?

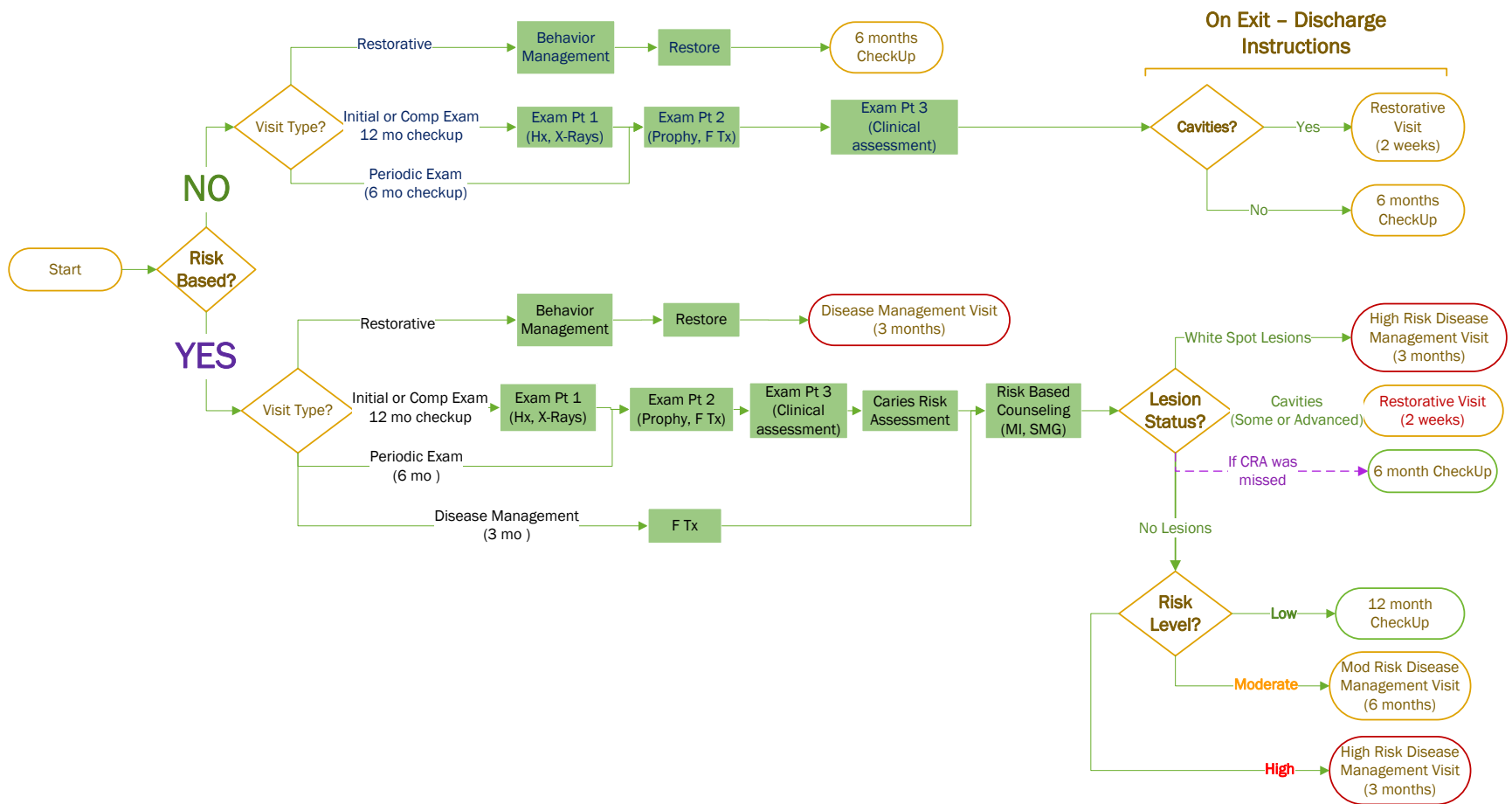

Figure 15. Clinic Workflow and Decision Logic

Developing Simulation Model

Object roles, boundaries and level of detail

The decision about what to include and exclude from the model initially was approached with the hopes that the model would have wide application. However, I quickly learned this would require a much heavier investment in development. I had to settle for certain levels of abstraction that, while less realistic, would still allow us to observe structure and behavior. I made decisions about the levels of detail to include about the following:

Caries disease Caries outcomes are generally reported as the number of decayed, missing, or filled teeth or tooth surfaces. (DMFT/dmft, DMFS/dmfs, or dmf). The caries disease progression process can occur concurrently in several teeth at a time and at different rates. There is literature on rates of decay, and what quadrants of the mouth are most likely to be affected first. However, this would have involved a level of complexity — tracking the disease process on each tooth or tooth surface, in each child — that at this point I did not deem necessary. Therefore, I represented caries disease at a fairly abstracted level: an individual can be only in one state of disease at a time. It could be considered the most advanced state observed. It was important that it be possible to identify a child with white spot lesions in order to detect differences between intervening or letting the initial lesion progress to a cavity. Often in longitudinal dental studies a specific tooth is selected to track and report on; we could imagine that we are tracking the state of such a tooth (Llena & Calabuig, 2017; Peyron, Matsson, & Birkhed, 1992).

Clinic operations and resource use In order to detect the effect of risk and disease changes on the productivity of the dentist, some relevant details of the care process needed to be specified, including time for procedures (such as counseling or conducting a caries risk

assessment) and space use. Because this model is not concerned about efficiency and production inputs (dentists, DAs, etc.) as much as outputs, as long as service blocks have time assignments, that is expected to be a sufficient level of detail. In this model, the patient behaviors during the care process are not included — only what the dental clinic does in response to the patient’s condition. We omitted space and staff resources in this iteration of the model as well as constraints on scheduling. Table 3 lists the set of assumptions made about the disease process and clinic operations.

Table 3. List of model assumptions

Caries Disease related	Dental Care related
<ol style="list-style-type: none"> 1. There is a high prevalence of the bacteria in the population — estimated at 90% 2. Child agents inherit their mother’s level of sugar exposure and toothbrushing frequency 3. Agents brush their teeth with fluoridated toothpaste 4. Toothbrushing with fluoridated toothpaste has two effects: <ol style="list-style-type: none"> a. A mechanical effect of removing bacteria (in the SD model) b. A chemical protection from the fluoride in toothpaste that protects teeth from the effects of plaque (in the lesion development hazard) 5. The protective effect of toothbrushing is less than the harm of sugar in growing the amount of bacteria 6. Bacteria levels reach a maximum of 10,000,000, at which point 10% will be eliminated to maintain bacteria stock within a range. 7. The effectiveness of risk-based counseling (~40%) is not cumulative across visits, probabilities are independent. 8. Disease will progress faster in children with primary teeth than in agents with permanent teeth (ChildAge cutoff) 	<ol style="list-style-type: none"> 1. Agents always have an appointment 2. Agents attend their appointment (missed appointment probability =0) 3. Agents attend either a risk-based clinic or a traditional one, and never change 4. Adult agents will change from a pediatric to an adult clinic when they reach the maximum age for a pediatric clinic, but they will attend the same type of clinic they were assigned to as a child (risk-based or traditional) 5. Caries risk assessment is only conducted at comprehensive or periodic exams, not disease management visits (i.e.: 12- and 6-month checkups) 6. Services are reliably provided at every visit. <ol style="list-style-type: none"> a. A CRA is performed 100% of the time for visits that include a CRA. It is never missed. b. Restorative care is always completed within a visit 7. Restorative care for younger children can take longer (behavior management) 8. This is a closed system — the population equals the patient panel.

The sequence of services that are part of the care processes at dental clinics can vary from what might occur in the real world; but they were ordered in a way to accommodate the logic of the visit, relative to other visits. In this model the sequence is important only for determining decision points and sensitivity tests.

Determining model structure and logic

Model structure and logic refer to how I have characterized the relations between activities in the model. Activities represent dynamic behaviors that result when objects interact with each other. The structure refers to the characterization of this dynamic behavior. This includes both the flow logic of objects through the system and the decision logic used to determine transitions between states. A description of this logic is incorporated into the description in the next section.

Simulation model formulation

The formulation of the model involves translating the conceptual model into computer code and then into an executable. This involves selecting the most appropriate simulation methodology and an appropriate computer language or software. As discussed above, I selected an agent-based model to simulate individual characteristics and behaviors leading to health trajectories, and then a discrete event simulation to represent the dental care process. An SD model was added during the development process to better represent the accumulation of bacteria in an agent's mouth in response to their health habits (see Table 4).

Table 4. Simulation methods used to model caries disease and dental care

METHOD	APPLICATION	MAIN VARIABLES/PROCESSES
Agent-Based Model (ABM)	To model the progression of disease in individual agents based on their individual risk and protective factors and dental care.	<ul style="list-style-type: none"> • Lesion Status • Infection status • Risk Status • Fluoride treatments • Toothbrushing frequency • Care seeking
System Dynamics (SD)	To model the accumulation of caries causing bacteria in the mouth of an individual as a result of being inoculated with the <i>Streptococcus mutans</i> and behaviors	<ul style="list-style-type: none"> • Infection status • SM Bacteria • Sugar exposure Frequency • Toothbrushing Frequency
Discrete Event Simulation (DES)	To model the dental care process differentiating: <ul style="list-style-type: none"> • A traditional one size fits all approach • A risk and disease management approach 	<ul style="list-style-type: none"> • Care based on Lesion and/or Risk • Appt. scheduling based on risk • Visits by type and risk

I implemented the hybrid model using AnyLogic 8.2.3 software, Professional and Personal Learning Editions (PLE). AnyLogic uses object-oriented language and is the only software that supports integrated multimethod modeling of discrete event, agent-based simulation, and system dynamics (AnyLogic, 2015; Borshchev & Filippov, 2004). It uses Java code for its modeling language and is able to handle both continuous and discrete time events in the same simulation, unlike other software like NetLogo that uses discrete steps. AnyLogic has a user-friendly and rich graphical interface that allows even a novice modeler like me to interact with the software and reason through output. I received technical assistance from several computer science doctoral students at the University of Saskatchewan studying under Professor Nathaniel Osgood.⁶ They provided support for translating the conceptual design into programming

6. Kurt Kreuger and Winchell Qian helped with the initial conceptualization of the model as teaching assistants for the ABM Bootcamp at the University of Saskatchewan. Krueger and Alex Dumais provided support for

language, and as the model developed to finalize and refine the model, debug and produce outputs. At the end, I worked most closely with Alex Dumais, a recent graduate of the University of Saskatchewan computer science program in a virtual collaboration using Zoom. I would define the logic and model structure and outputs and Alex provided the programming expertise and would build the pieces in real time with me, troubleshooting offline as needed.

Agent-based models and ABM hybrid models are often described using a framework referred to as “O! PARTIES” proposed by Professor Osgood in his ABM Bootcamp trainings (Osgood, 2013). This framework, which I will follow to describe how I operationalized the concept into the simulation model, outlines the important elements to include when describing the model formulation:

- OUTPUTS
- PARAMETERS (A pre-specified assumption)
- ACTIONS (Things that cause a change in state)
- RULES (Governing actions)
- TIME (What are the characteristics of time? Time horizon? Continuous vs. discrete?)
- INTERVENTIONS
- ENVIRONMENT (Network? Geographic? Continuous spatial non-geographic? Gridded space?)
- STATE (What aspects of the status of the model/agents/context need to evolve over time?)

Outputs of the model

The outputs for this hybrid model are listed below. They are two pronged;

Figure 16 depicts where in the model they come from. Of note is that most of these outcomes are generated over time and can also be analyzed at various points in time, or at the end point.

translating the conceptual design into programming language, and provided the bulk of programming assistance to finalize and refine the model, debug, and produce outputs. Allen McLean provided limited assistance with the discrete event simulation.

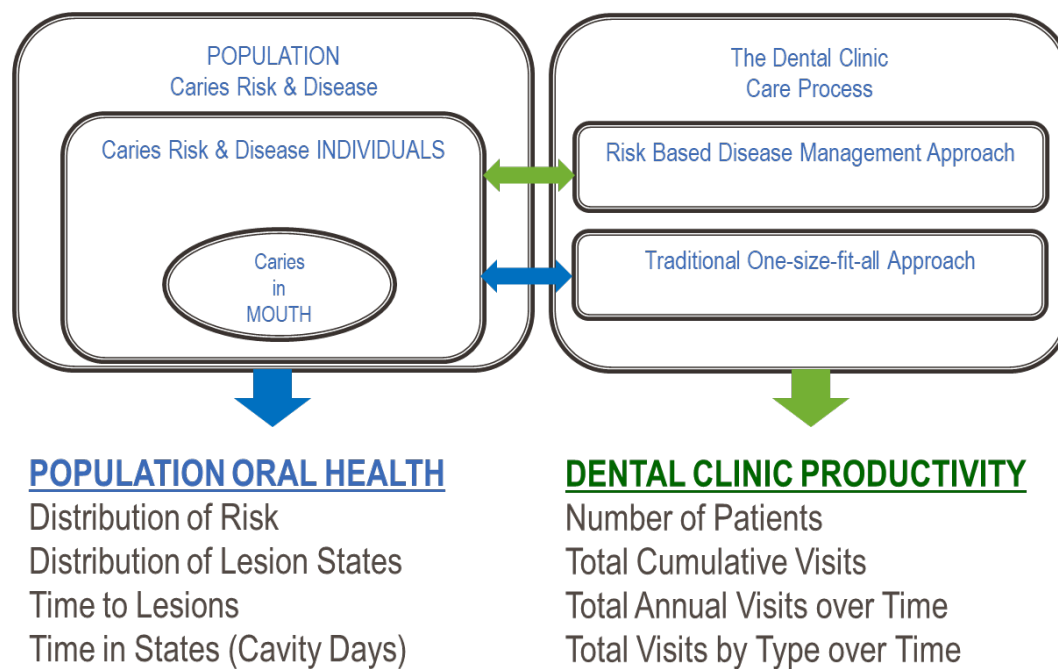

Figure 16. Model Outputs from different parts of the model

Parameters – agents and entity characteristics

ABM Agents & Properties

There are two types of agent in this model: persons and clinics. The dynamics of clinics are characterized in the discrete event simulation. Persons are the agents in the agent-based model.

Parameters and variables

AnyLogic makes use of parameters and variables to define agent or model characteristics and transitions. Parameters are generally used for defining a characteristic statically. In a given simulation they are usually a set value changed only at particular points in time if needed to adjust model behavior, for example, initial conditions or effectiveness of an intervention. I also used parameters for aspects where data is not readily available so that if stakeholder argue their values they can be modified as part of experiment set-up conditions.

Variables can store the results of model simulation or can model some characteristic of objects that may change continuously during simulation, such as age or time in a risk category. AnyLogic also uses functions that are types of algorithms that call up actions. These actions can involve any of the elements in the model, mathematical, logical, or statistical operations; for example, they can look up values and compare them to help an agent decide whether to move states.

Agent characteristics that are captured variables, parameters and functions include:

- Age/birth time
- Connection between mother and child dyads, mother/child status
- History of lesions
- History of topical fluoride applications
- A first appointment, age at first appointment
- Visit history
- Type of clinic assigned to: risk-based or traditional

DES and resources

There are four types of clinics defined by the age of patients and the approach to care: pediatric or adult clinics, traditional or risk-based. There is an age threshold after which children will no longer be seen at the pediatric clinic (age 12 in these experiments) and will then go to an adult clinic. This can be changed in the experiment setup, and the data will be reported separately for a pediatric population. This was done in order to focus on the effects at the pediatric clinic without mixing with other, adult patients.

The next category is whether a clinic is a traditional one-size-fit-all clinic or a risk-based clinic that includes risk and disease management in its protocol. Once at the clinic, the process for a visit is differentiated based on the type of visit: a comprehensive exam, a periodic exam, a disease management visit or a restorative visit. Each type of visit includes service blocks for the types of services included; each service is associated with an amount of time and has not yet but

could be associated with resources such as staff and space required to complete the action. Also still to be added are limits on the time the clinic is open and closed.





Actions & rules

ABM states, transitions and pathways

AnyLogic uses statecharts as a visual construct that enables the definition of event- and time-driven behavior of agents.

Statecharts and transitions

A *statechart* is a visual construct that defines behaviors based on *states* and *transitions* between states. An agent can, at any moment, be in exactly one alternative or simple state (Borshchev, 2013). Movement between the different states is defined by transitions, each of which contains a *trigger*, which can be triggered by the following:

- a message being sent, depicted by the icon 
- a condition being met, depicted by 
- a simple timeout, depicted by  i.e., after a specified amount of time
- a rate, depicted by ; the rate is drawn from an exponential distribution parameterized with the given rate.

Once the transition is triggered, changes are instantaneous, and a new set of reactions may come into play related to the new state. Other actions can be associated with transitions when entering or exiting states. These states are part of an agent's history, and a set of events that will influence its future as well. The model keeps track of each agent's biography concerning the various states, parameters, or variables. When the model runs, the *Person level* view of AnyLogic (Figure 21 on page 191) highlights the active states of statecharts as well as the transitions that are scheduled to be fired or have just fired. This allows us to view and track an individual across time and states.

In an execution mode, this feature can help with debugging of statecharts and transitions and to observe model behavior. These transitions embody the decision framework for the model, and it is where factors are either endogenously or exogenously determined — based on factors within the model or external to it.

Table 5 below summarizes the various states and the rules governing how an agent would transition between states that determine when an agent is born, how their oral hygiene and sugar-eating habits are represented, how they get infected and have bacteria loads grow, how they seek care and receive fluoride treatment and counseling, and how all of these are combined to determine disease progression and level of risk. I will elaborate on two of the aspects that are central to the model: the bacteria level and lesion development. For a more detailed description of the other statecharts and transitions, see Appendix 2.

In the initial phase of model development, I was overwhelmed by all the interactions of risk and protective factors, and it was difficult to design a logic that contained so many interactions. Then I came across the article that identified the disease as the result of two homeostatic processes, one process leading to bacterial growth, the result of which is the second process, a dynamic imbalance between remineralization and demineralization. The first represented in the SD model, the second in the ABM. This helped to organize and order the effects of the multiple factors in order to translate it into something the computer could understand. Developing this type of simulation model forces one to think deeply about and understand the process being modeled in order to represent the mechanisms in an explicit manner. Appendix 3 shows a series of questions I had to iterate through in this process, some of which I could answer better than others.

The main challenge in this part of the model is to define the relative weights of various parameters at the individual level to set rules that determine when and how someone will progress from one lesion state to the next.

Table 5. Summary of Statecharts, states and transition rules

Statechart	States	Transition Rules
1. Childbearing	<ul style="list-style-type: none"> • Prechildbearing Age • Childbearing Age <ul style="list-style-type: none"> ◦ Not pregnant ◦ Pregnant • Post Childbearing Age • Death 	<p>To childbearing — condition based on age Not pregnant to pregnant — Rate (1.0/5)) Pregnant to not pregnant — Timeout (9 months) To postchildbearing — Timeout based on age (35years) Timeout — At age 35 years</p>
2. Sugar exposure	<ul style="list-style-type: none"> • Low Sugar • Moderate Sugar • High Sugar 	<p>Down — Rate of protective behavior habit decay Up — reduction based on effectiveness of MI and message from clinic</p>
3. Toothbrushing	<ul style="list-style-type: none"> • Twice Daily • Once Daily • Less than Daily 	<p>Down — Rate of possible protective behavior decay Up — increase based on effectiveness of MI and message from clinic</p>
4. Infection status	<ul style="list-style-type: none"> • Not infected • Infected 	<p>Down — Rate based on probability of infection associated with mother's infection and lesion status Up — Reversal is not possible</p>
5. Bacteria level — (SD submodel)	<ul style="list-style-type: none"> • System Dynamics • Stock of bacteria count 	<p>Bacterial growth by increased sugar Bacterial reduction by brushing</p>
6. Care seeking	<ul style="list-style-type: none"> • Have Appointment • Under Care (in DES) 	<p>Timeout to appointment Exited Care message from clinic</p>
7. Fluoride protection level	<ul style="list-style-type: none"> • No fluoride • Protected by 1 Tx • Protected by 2 Tx • Protected by 3 Tx • Protected by 4 Tx 	<p>Down — Message from clinic Up — Timeout decay rate of 3 months</p>
8. Lesion development	<ul style="list-style-type: none"> • No Lesions • White Spot Lesions • Some Cavities • Advanced Cavities 	<p>Down (disease progression) — Rate determined by the infection status, the lesion development hazard rate, and their current state multiplier. Up (treatment of disease) — WSL to No Lesions (message of WSL healed), Some cavities or Advanced cavities to No Lesions (message — cavities restored)</p>
9. Risk status	<ul style="list-style-type: none"> • Low Risk • Moderate Risk • High Risk 	<p>Down (increased risk) — message based on assessment of - Lesion Status or restorations - Sugar frequency - Brushing frequency - Fluoride varnish protection Up (reduced risk) — possible based on a timeout from last restoration, but checks other factors to confirm'</p>

Bacteria level – a systems dynamics submodel

The bacterial process starts with a vertical transmission from the mother. Mothers with a higher count of bacteria are likely to have more advanced lesions, and vice versa. Therefore, I reasoned that children with mothers with more disease would acquire the infection at a higher rate. Once a child is infected, the bacteria grows based on how much sugar they are exposed to and how frequently they brush their teeth. Since research shows that children tend to have habits that closely align with those of their parents, children are started out with the same habits as their mother.

Studies have utilized a scale referred to as the Berkowitz scale of *S. mutans* that have been associated with varying levels of disease in children and adults. Initially I had developed a nested statechart that mapped to the Berkowitz levels of SM. However, with a greater understanding of the centrality of the level of bacteria, we decided to approach this more dynamically, in a way that situates the opposing effects of sugar exposure and toothbrushing frequency on the stock of bacteria (see Figure 17).

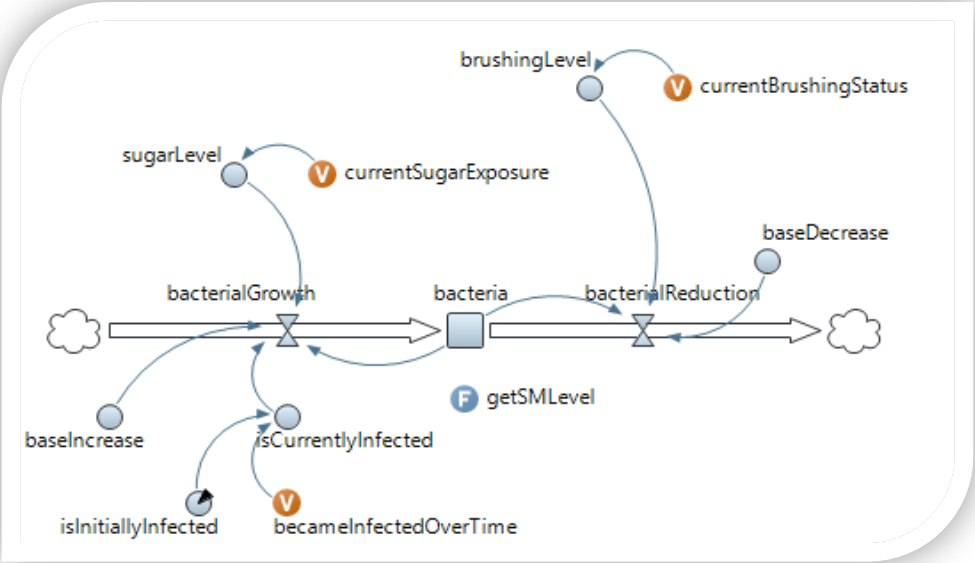

Figure 17. System Dynamics submodel of bacterial CFU/ml.

This model centers on a continuous stock of bacteria, and a flow in resulting from bacterial growth, and a flow out resulting from efforts to reduce bacteria. Sugar exposure will promote the growth of bacteria, and the mechanical removal by toothbrushing will reduce the amount of bacteria in the mouth. As the model runs, one can see the stock growing or not based on behaviors.

Lesion development

With the various states discussed thus far, we have covered the part that presents the bacterial homeostasis (or lack thereof). Now we can represent the mineral homeostasis, the de- and remineralizing process that determines the disease state or “lesion status” of an agent. The lesion status statechart represents one of the main model outcomes of interest: oral health status and distribution of disease in the population. It also will influence the dentist’s decisions and actions during a care visit.

A child will normally end up with 20 primary teeth, each of which has five surfaces that could be affected. Primary teeth will start shedding from around age 6 to 12, eventually transitioning to 32 permanent teeth in adults. However, in this somewhat stylized model I have chosen to represent lesions not at the level of the tooth but the individual. Hence I abstracted and simplified the combination of degree and severity into four lesion states that an agent could be in representing the condition of the tooth (or teeth) with the worst state of decay in that agent: no lesions, white spot lesions or initial lesions, some cavities, or advanced or severe cavities.

- ***No lesions*** include agents who have never had lesions as well as those that do not have any “active” lesions. Once cavities (either some or advanced) are restored, an individual returns to a “no lesions” state, but the history of lesions is preserved.
- ***White spot lesions*** are the initial, shallow lesions that affect the enamel, and can be remineralized or “healed” with proper fluoride therapy and reduction of risky behaviors.

- *Some cavities* represents a few, not severe cavities, involving a few teeth compared to *advanced cavities* that are deeper and/or involve many teeth. In very young children, restoration of these might have to be done under sedation or general anesthesia. For purposes of this model, we include a treatment complexity and behavior challenge factor that adds time to the procedures, all of which are performed onsite.

Transitions

There are several transitions to define in this statechart:

- 5) Disease Progression:
 - No lesions to white spot lesions
 - White spot lesions to some cavities
 - Some cavities to advanced cavities
- 6) Treatment of disease
 - White spot lesions to no lesions (remineralized)
 - Some or advanced cavities to no lesions (filled or restored)

Disease progression transitions are triggered by rate transitions that attempt to represent the probability of an agent progressing in disease based on their unique combination of risk and protective factors (bacteria, toothbrushing, and fluoride protection level). Transitions involving the treatment and improvements in lesion status are transitions triggered by a message received when a treatment is provided that “heals” the lesions, i.e., cavities are filled (if some are advanced cavities) or white spot

lesions receive a complete regimen of fluoride treatments.

The probability of disease progression is conceptualized as a *hazard rate*, expressed as a probability over time, of developing lesions; it accounts for several

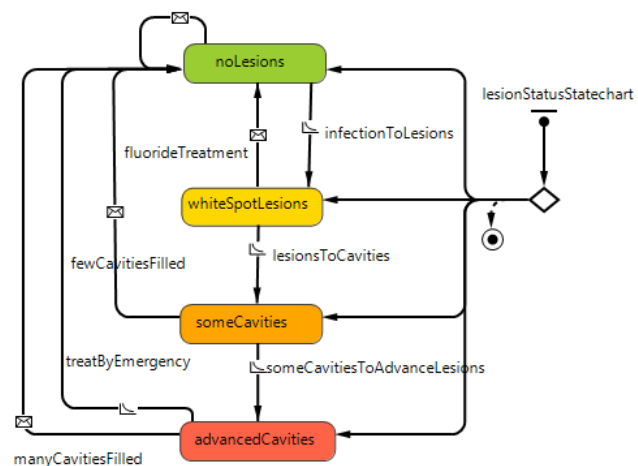

Figure 18. Lesion Status State Chart

predictors or explanatory variables. The “*lesion development hazard*” (1) is calculated as (h) where:

$$\begin{aligned}
 h = h_0 * \exp & (\beta_{SM} \times \log (\text{Bacteria Level}) \\
 & + (\beta_{Fluoride} \times \text{Relative Fluoride Level}) \\
 & + (\beta_{brushing} \times \text{Toothbrushing}) \\
 & + (\beta_{BabyTeeth|child})
 \end{aligned}
 \tag{1}$$

The hazard is calculated by a base hazard rate (h_0) that is multiplied by a coefficient based on the agent’s current lesion state, 1, 0.7, 0.5 for no lesions, white spot lesions or some cavities, to account for the different rate of progression at different stages of the disease. Terms are added for relative fluoride exposure (number of applications in a year), frequency of daily brushing with fluoridated toothpaste, and bacterial load (from the SD model stock). A final term, I_{child} , raises the hazard if the agent is a young child. Baby teeth have thinner and more porous enamel, which can demineralize faster than permanent teeth (1 for children, and 0 otherwise). The coefficient is based on the different rates of disease progression between primary teeth and permanent teeth. These factors are formulated as an exponential so that the rate will never be less than zero.

Risk was determined based on the combination of factors listed in Table 6, that include factors that a dentist can easily and readily assess during a dental visit.

Table 6. Factors associated with risk levels

LOW RISK	MODERATE RISK		HIGH RISK	
Brush 2 / day AND LOW sugar	Brush < 1 /day OR HIGH sugar	Brush < 1/day AND LOW FV(<2)	Brush < 1/day AND HIGH sugar	Brush < 1/day AND NO FV
No Lesions	No Lesions		Has Cavities or WS Lesions	

Last restorations
> 24 months ago

Last restorations
>12 months ago

Restorations
< 12 months ago

The dental care visit (DES)

When an agent enters the “UnderCare” state in the ABM they immediately enter the (nearest) clinic assigned to them (traditional or risk-based), a visit event is triggered, and the workflow process is initiated. The agent brings with it all its states and biography, and the model tracks the services the agent receives. Once the patient enters the clinic, Figure 19 on page 180 depicts the workflow and decision nodes differentiating the risk-based approach to care from the traditional surgical approach.

The dental clinic’s objective is to improve the oral health of patients. Clinics will do this based on different protocols for providing restorative and/or preventive and disease management services at varying intervals. Being able to demonstrate the feasibility of simulating the tradeoff between approaches and across many patients and time is an important contribution that can lead to a more robust examination of the tradeoffs and help bridge the mindsets of clinicians and population health advocates

To capture the interaction between the patient’s oral health status and the dentist’s actions in response, I included several factors that the dentist can influence directly or indirectly:

1. Apply fluoride varnish at more frequent intervals for patients that have lesions or are at high risk for lesions.
2. Acknowledging risky behaviors (frequency of sugar consumption, low frequency of toothbrushing), they can apply their best motivational interviewing skills and help caregivers set self-management goals to reduce their child’s risk of caries.
3. A risk-based approach would shorten the interval between visits, and
4. If cavities are observed, they can be restored

Discrete Event Simulation Elements

The typical elements of a DES model include entities, attributes, resources, events, workflows, and relationships.

Resources in this DES include only the dental clinic's time. In trying to maintain simplicity, both the staffing and physical space have not been introduced yet but are possible additions. I considered adding dental chairs and counseling rooms but decided to first pilot it without.

Events occur at specific points in time. In this model, dental visits are the main events occurring when a patient enters care. Events are triggered, similar to the triggers in the ABM moving someone to a new state. Dental visits are triggered by a message (an appointment). At each event, the patient's attributes are evaluated, their lesion status and/or risk assessed, and the care delivered is based on this information. Clinic actions include conducting an exam, history, cleaning, apply fluoride varnish, restore cavities, (for a risk-based clinic) provide risk-based counseling, and change the frequency of follow-up appointments based on risk.

I kept the clinical flows of the risk-based and traditional clinics as similar as possible, except for aspects that relate to caries risk assessment, risk-based counseling and risk-based scheduling. There are four types of visits, each with a series of services provided, and each can have different intervals:

- **A restorative visit** Restorative care does not differ across the two types of clinics. If agents have some cavities or advanced cavities at a visit, they are scheduled for a restoration visits at a visit within 2 weeks. Younger children can require additional time to manage the behavioral aspects of the visit, and their ability to sit still for the procedure; this may require sedation or other approaches. Therefore, I added a possible delay, which will vary, based on their individual behaviors between 15 to 60 additional minutes. Following restoration, patients return to a “no lesion” status and the model counts the type of lesion restoration in the agent's history.
- **A comprehensive exam / initial exam** (every 12 months), or a **periodic exam** (every 6 months) The main differences in the oral exam visits are whether a caries risk

assessment is conducted, the type of counseling or education that is provided, and whether white spot lesions are treated:

- Caries risk assessment and risk-based counseling.
 - A traditional dentist provides a generic advice and information, giving “oral health instruction” (OHI). A risk-based clinic will base the counseling on the specific risk factors of each patient, using motivational interviewing techniques to help parents/patients choose self-management goals. Counseling is can have a small influence on the probability of shifting behavior to a lower risk state of toothbrushing and sugar exposure. Some
 - At exams, checkups and disease management visits, all patients receive preventive fluoride if they have no lesions or white spot lesions
- **Treatment of white spot lesions** White spot lesions can be treated with fluoride so that the demineralization is reversed and the lesions arrested. However, a traditional clinic might take the approach of observing them. Therefore, if an agent has white spot lesions and they attend a risk-based clinic, they are assigned to a high-risk schedule to receive fluoride and counseling every three months. At a traditional clinic, the white spot lesions are not treated, and the patient would return like a patient with no lesions every six months.
- **Return visits / Risk-based scheduling** This is an important structural aspect of the approach and a way to divert increased resources and attention to higher risk patients. Risk-based clinics manage risk of disease by adjusting visit intervals based on risk instead of a standard six-month recall for everyone (i.e., one-size-fits-all-approach). Higher risk would have a shorter interval (one to three months), low risk a longer one (12 months). This allows for greater fluoride exposure as well as reinforcement of health behavior messages
- **A disease management visit** (only at a risk-based clinic) This includes fluoride varnish and risk-based counseling. This is not a typical visit offered by dentists, since most dentists will want to do an exam of some sort so they can bill for the visit; counseling is generally (at present) a billable procedure. In a value-driven environment, a short visit where fluoride is applied and self-management goals are reinforced is just what a high-risk patient needs, and there is no need to tie up more of a provider’s time.

A *workflow* is associated with a visit that includes a series of discrete *services* that are provided.

Figure 19 shows how these two processes were operationalized.

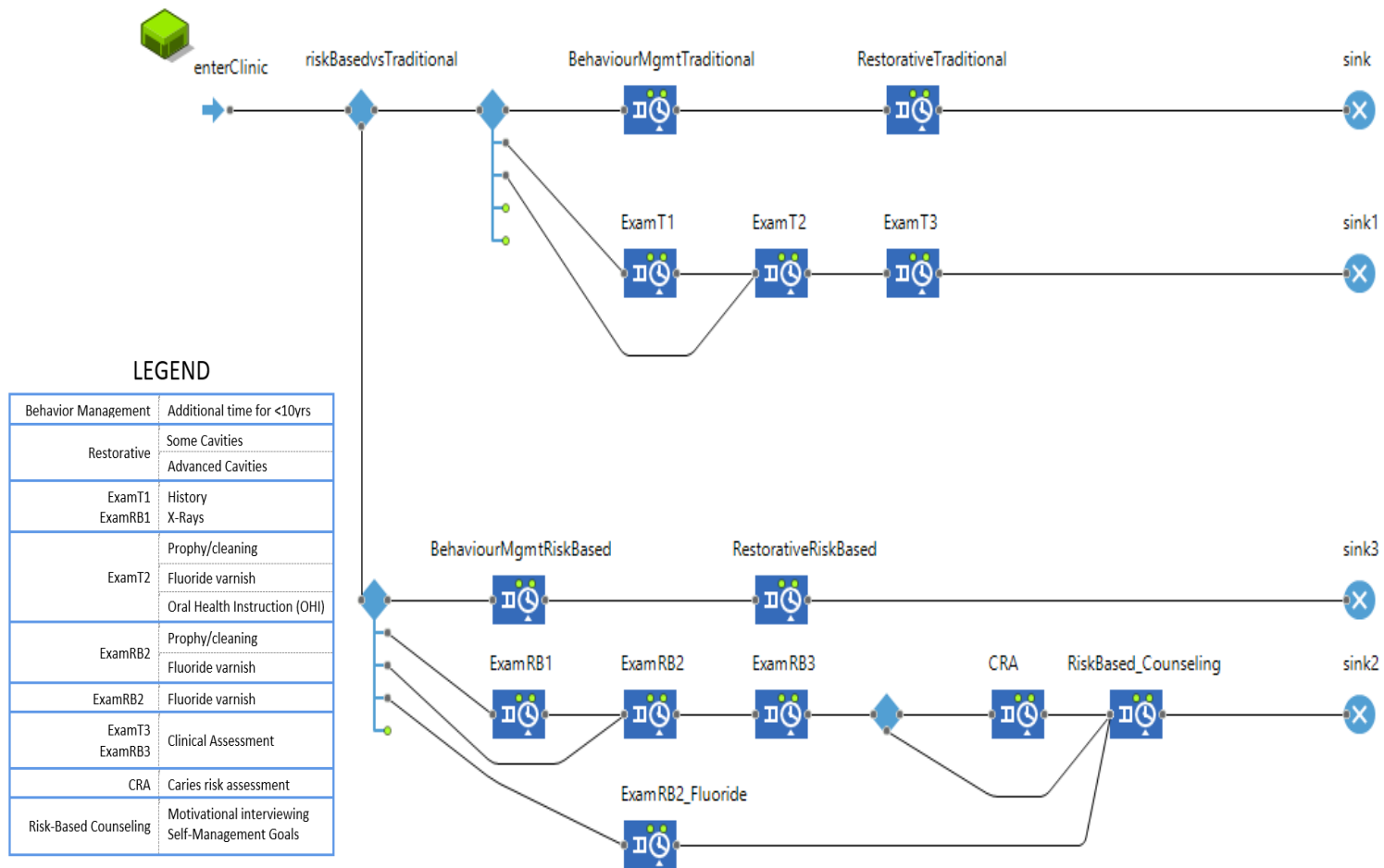

Figure 19. Discrete event simulation of the “traditional” and “risk-based” care process at a dental clinic

Time in this model is in days. The model simulates real time. Events, delays and services are all associated with an amount of time. Once a patient enters the DES process, services will take a fixed amount of time except for restoration. Time to do restorations will be impacted by the behavior management block which applies a uniform distribution of additional time needed based on the agent being a younger child. The younger the child the more involved the restoration will be, reflecting the possible need for sedation and/or behavior management.

In order to inform the time allocations of the model, I initially drew on my experience building workflow diagrams with staff from 12 federally qualified health centers in Los Angeles County as part of a quality improvement initiative. Then, I consulted with the clinic administrator at the UCLA School of Dentistry Children's Dental Center, who has over 25 years' experience running the clinic, regarding time allocations to procedures and visit types. After summarizing the steps and allocating times to them, I confirmed their validity with Dr. Ramos Gomez, Professor of Pediatric Dentistry at UCLA School of Dentistry, who runs the Infant Oral Health Clinic and has authored several publications on CAMBRA protocols. I have initially provided a generous 15 minutes for conducting the CRA and counseling, compared to only five minutes for OHI.

Table 7. Services provided by visit and clinic type, with procedure times and visit intervals

Visit Type & Services	Traditional	Risk-Based	Traditional	Risk-Based
	Time for procedure or visit		Interval to Visit	
Restorative Visit	1:15–2:30 hrs	1:15–2:30 hrs	2 weeks	2 weeks
Behavior Management (Additional time for <10yrs)	15–60 mins ⁷	15–60 mins		
Restoration for...				
Some Cavities	60.0 minutes	60.0 minutes		
Advanced Cavities	90.0 minutes	90.0 minutes		
Comprehensive Exam	30 minutes	40 minutes	12 months	12 months
ExamT1 / RB1				
History & X-Rays	10.0 minutes	10.0 minutes		
ExamT2 / ExamRB2				
Prophy/cleaning	7.0 minutes	7.0 minutes		
Fluoride varnish	3.0 minutes	3.0 minutes		
Oral Health Instruction	5.0 minutes			
ExamT3 / ExamRB3				
Clinical Assessment	5.0 minutes	5.0 minutes		
Caries risk assessment		8.0 minutes		
Risk-Based Counseling				
MI & SMGs		7.0 minutes		
Periodic Exam	20 minutes	30 minutes	6 months	(Mod–Low Risk) 6–12 months
ExamT2 / ExamRB2				
Prophy/cleaning	7.0 minutes	7.0 minutes		
Fluoride varnish	3.0 minutes	3.0 minutes		
Oral Health Instruction	5.0 minutes			
ExamT3 / ExamRB3				
Clinical Assessment	5.0 minutes	5.0 minutes		
Caries risk assessment		8.0 minutes		
Risk-Based Counseling				
MI & SMGs		7.0 minutes		
Disease Management		10 minutes		3 months (high risk)
ExamRB2_fluoride				
Fluoride varnish		3.0 minutes		
Risk-Based Counseling				
MI & SMGs		7.0 minutes		

7. The additional time is based on the following probability distribution: Triangular (15, 60, 30). A triangular distribution has the form triangular (min, max, mode) — so a minimum of 15, maximum of 60 and a most likely value of 30.

Time and schedules

The model time is in days; agent states are updated daily, provider visits occur in real time and are captured daily but are reported and tracked monthly or yearly. Population distributions for risk and lesion status are also reported per year.

When the model is initialized it starts with adults and children. There is an initial “warm in” period during which we allow the model to run until functional distributions are reached. In this model, that takes approximately one year.

Model inputs and initialization

To start a simulation model, one must decide what the initial conditions are and how to distribute agents across the states of a statechart. Table 8 lists the initial settings for the main parameters in the baseline simulation model.

Table 8. Initial parameter settings for baseline simulation

Parameter	Current value
<i>Relating to the SD Bacteria</i>	
Sugar Increase Hazard (<i>rate that behaviors may worsen</i>)	0.1
Brushing Decrease Hazard (<i>rate that behaviors may worsen</i>)	0.0
Rate of Increase per Sugar Level (multiple)	0.01 Low, 0.025 Mod, 0.035 High
Rate of Increase per Brushing Frequency (multiple)	0.03 2/day, 0.02 1/day, 0.005 <1/day
<i>Relating to the Lesion Development Hazard</i>	
Multiple based on Lesion state	1 to WSL, 0.7 to SomeCav, 0.5 to Adv Cavities
Beta Lesion Development Based on F exposure	-0.1
Beta Lesion Development Based on SM Level	0.2
Beta Lesion Development Based on Brushing Frequency	-0.05
Beta Baby Teeth Lesion Development	1.5
<i>Initial population distributions</i>	
<i>Percentage distribution</i>	
Initial lesion status	90-5-3-2 (NoLesion, WSL, Some, Advanced)
Initial brushing status	60-30-15 (x2/day, 1/day, <1/day)
Initial sugar exposure	20-50-30 (Low, Mod, High)
Initial risk distribution	65-25-10 (Low, Mod, High)
Initial appointment time	12-72 months

Table 9 describes how I arrived at the various input parameters used to inform and calibrate the distributions for the initial states as well as the transition rates.

Table 9. Input values for initial distributions, parameters related to disease progression.

Variable	Reference Information	Assumptions & Parameter Values									
Population Characteristics — Prevalence and changes over time											
Age distribution – US population by age	(U.S. Census Bureau, 2017a)	Initialized the population using a uniform distribution from 0–34 years of age									
	Age Total Age Total										
	<5 19,927,037 20–24 22,381,028										
	5-9 20,429,799 25–29 22,890,884										
	10–14 20,618,233 30–34 20,915,803										
15–19 21,129,999 35–39 19,503,572											
Infected with Strep mutans	As reported by NHANES 2011–2012(CDC, 2013), the percentage of adults that have experienced caries is: <ul style="list-style-type: none"> • 82% 20–34 age group • 94% 34–49 age group • 91% 20–64 age group We can assume anyone that has had caries is infected with <i>S. mutans</i> or other caries causing bacteria.	90% initially infected Used Berkowitz MS scale to calibrate SD bacteria stock									
		<table border="1"> <thead> <tr> <th colspan="2">MS Score & Range</th> </tr> </thead> <tbody> <tr> <td>0</td> <td><10⁴ CFU/ml saliva</td> </tr> <tr> <td>1</td> <td><10⁵ CFU/ml saliva</td> </tr> <tr> <td>2</td> <td>10⁵–10⁶ CFU/ml sal.</td> </tr> <tr> <td>3</td> <td>>10⁶ CFU/ml saliva</td> </tr> </tbody> </table>	MS Score & Range		0	<10 ⁴ CFU/ml saliva	1	<10 ⁵ CFU/ml saliva	2	10 ⁵ –10 ⁶ CFU/ml sal.	3
MS Score & Range											
0	<10 ⁴ CFU/ml saliva										
1	<10 ⁵ CFU/ml saliva										
2	10 ⁵ –10 ⁶ CFU/ml sal.										
3	>10 ⁶ CFU/ml saliva										
Toothbrushing frequency	Published rates varied significantly based on population assessed and categories used and few report on young children. Used own analysis of unpublished parent survey data collected by 6 Six Federally Qualified Health Centers in Los Angeles County over a period of 6-8 months in 2015 ⁸ . Percent of children who had their teeth brushed (0–12 years, mean age 3.35): <ul style="list-style-type: none"> • 64% — Twice or more daily • 29% — Once daily • 6% — Less than once daily 	<ul style="list-style-type: none"> • 65% Twice daily • 30% Daily • 5% Less than once daily 									

8. Part of the UCLA First 5 LA Oral Health Quality Improvement Learning Collaborative (See Crall, Pourat, Inkelas, Lampron, & Scoville, 2016).

Table 9. Input values for initial distributions, parameters related to disease progression. (continued)

Variable	Reference Information	Assumptions & Parameter Values																																																		
Sugar exposure	Peres et al. (2016) (Brazil) 6-18 year old children: <ul style="list-style-type: none"> • 20% high sugar consumers • 40% upward consumers • 40% low consumers 	A distribution for the baseline scenario that is close to Peres’s study, but a bit more aggressive where <ul style="list-style-type: none"> • 20% high • 50% moderate • 30% low levels Based on the assumption that added might be higher in the US than in Brazil.																																																		
	NHANES 2005-2008 (Ervin, 2012 cited by Marshall, 2015) reported total energy from added sugars ⁹ <ul style="list-style-type: none"> • 16.3% 2–19-year-old children • 13.5% 2–5-year-old girls • 17.5% 12–19-year-old boys Winpenney, Penney, Corder, White, & van Sluijs (2017) — high sugar intake <ul style="list-style-type: none"> • 12.8% among Australian adolescents • 17.3% in US adolescents 																																																			
Cavities	<table border="1"> <thead> <tr> <th rowspan="2">Age</th> <th colspan="2">NHANES 2011-12^φ</th> <th colspan="2">NHANES 2005-2008^δ</th> </tr> <tr> <th>History</th> <th>Untreated</th> <th>History</th> <th>Untreated</th> </tr> </thead> <tbody> <tr> <td>2–8</td> <td>36.7%</td> <td>14.3%</td> <td></td> <td></td> </tr> <tr> <td>6–11</td> <td>21.3%</td> <td>5.6%</td> <td>38.7%</td> <td>20.4%</td> </tr> <tr> <td>12–19</td> <td>58%</td> <td>15.3%</td> <td>52%</td> <td>13.3%</td> </tr> <tr> <td>20–44</td> <td></td> <td></td> <td>79.2%</td> <td>25.1%</td> </tr> <tr> <td>20–64</td> <td>90.9%</td> <td>26.6%</td> <td></td> <td></td> </tr> <tr> <td>20–34</td> <td>82%</td> <td>27.3%</td> <td></td> <td></td> </tr> <tr> <td>35–49</td> <td>93.6%</td> <td>27%</td> <td></td> <td></td> </tr> <tr> <td>50–64</td> <td>97.4%</td> <td>25.5%</td> <td></td> <td></td> </tr> </tbody> </table>		Age	NHANES 2011-12 ^φ		NHANES 2005-2008 ^δ		History	Untreated	History	Untreated	2–8	36.7%	14.3%			6–11	21.3%	5.6%	38.7%	20.4%	12–19	58%	15.3%	52%	13.3%	20–44			79.2%	25.1%	20–64	90.9%	26.6%			20–34	82%	27.3%			35–49	93.6%	27%			50–64	97.4%	25.5%			Initial distribution: <ul style="list-style-type: none"> • 15% advanced • 15% some cavities Since the distribution of agents across states represents the agent’s current state, the “untreated” state reported by NHANES might be a closer reference point.
	Age	NHANES 2011-12 ^φ		NHANES 2005-2008 ^δ																																																
		History	Untreated	History	Untreated																																															
	2–8	36.7%	14.3%																																																	
	6–11	21.3%	5.6%	38.7%	20.4%																																															
	12–19	58%	15.3%	52%	13.3%																																															
	20–44			79.2%	25.1%																																															
	20–64	90.9%	26.6%																																																	
	20–34	82%	27.3%																																																	
	35–49	93.6%	27%																																																	
50–64	97.4%	25.5%																																																		
φ Dye et al., 2015a, 2015b δ Dye et al., 2012																																																				
White Spot Lesions	Mulligan, Seirawan, Faust, & Barzaga (2011) In LA disadvantaged children: <ul style="list-style-type: none"> • 29% had WSLs • 44% had cavities 	Initial distribution <ul style="list-style-type: none"> • 20% white spot lesions • 50% no lesions 																																																		
	Most other WSL prevalence data comes from orthodontic treatment literature, ranging from 2–96% (Guzmán-Armstrong, Chalmers, & Warren, 2010) (Douglass, Tinanoff, Tang, & Altman, 2001) Arizona disadvantaged 6–36-month-olds: <ul style="list-style-type: none"> • 25% had WSL by 34–36 months • Caries developed as early as 10–12 																																																			

9. <5% of total caloric intake as added sugar is the WHO recommended level.

Table 9. Input values for initial distributions, parameters related to disease progression. (continued)

Variable	Reference Information	Assumptions & Parameter Values																												
Risk	<p>Edelstein, Hirsch, Frosh, & Kumar (2015) used NYS parental reports of the condition of their children’s teeth from the National Survey of Children’s Health 2007.</p> <ul style="list-style-type: none"> • 63% low risk reported as “excellent or very good” • 26% moderate risk reported as of “good” • 11% to high risk reported as “fair or poor” <p>Hirsch, Edelstein, Frosh, & Anselmo (2012) Used Colorado Child Health Survey on caries experience as a proxy for ECC experience and risk distributions derived from NHANES pediatric cavity experience by income brackets for Colorado 0–5-year-olds:</p> <ul style="list-style-type: none"> • 50.8% were low-risk • 17.8% were moderate-risk • 31.4% were classified as high-risk 	<p>Used Edelstein 2015 since it was a bit more conservative and it was applied to the whole population, not just children</p> <ul style="list-style-type: none"> • 60% Low • 25% Moderate • 10% High 																												
Disease Dynamics – in the SD model and Lesion Development Hazard Rate																														
Risk of Child infection based on mothers bacteria or decay status	<p>Table describes our initial reasoning on the links, and times that might be reasonable. A bit more conservative than Berkowitz’s x9 reference below. Calibrated this before we added the SD model and considered level of bacteria.</p> <table border="1"> <thead> <tr> <th>Mom’s MS Status</th> <th>Infection Hazard Coefficient (i)</th> <th>Probability of infection (i/35)</th> </tr> </thead> <tbody> <tr> <td>Not infected</td> <td>0</td> <td>0</td> </tr> <tr> <td>Inf–no Lesions</td> <td>1.8</td> <td>0.05</td> </tr> <tr> <td>Inf–WSL</td> <td>2.3</td> <td>0.07</td> </tr> <tr> <td>Inf–Some Cav</td> <td>4.0</td> <td>0.11</td> </tr> <tr> <td>Inf–Adv Cav</td> <td>6.0</td> <td>0.17</td> </tr> </tbody> </table> <p>Berkowitz, Turner, & Green (1981) reported:</p> <table border="1"> <thead> <tr> <th>MS Score & Range</th> <th>% infants infected</th> </tr> </thead> <tbody> <tr> <td>0 <10³ CFU/ml</td> <td>6%</td> </tr> <tr> <td>1 <10⁴ CFU/ml</td> <td>16%</td> </tr> <tr> <td>2 10⁴10⁵ CFU/ml</td> <td>14%</td> </tr> <tr> <td>3 >10⁵ CFU/ml saliva</td> <td>58%</td> </tr> </tbody> </table> <p>Removal of active caries, with subsequent restoration of remaining tooth structure, in the parents suppresses the MS reservoir and minimizes the transfer of MS to the infant, thereby decreasing the infant’s risk of developing ECC.</p>	Mom’s MS Status	Infection Hazard Coefficient (i)	Probability of infection (i/35)	Not infected	0	0	Inf–no Lesions	1.8	0.05	Inf–WSL	2.3	0.07	Inf–Some Cav	4.0	0.11	Inf–Adv Cav	6.0	0.17	MS Score & Range	% infants infected	0 <10 ³ CFU/ml	6%	1 <10 ⁴ CFU/ml	16%	2 10 ⁴ 10 ⁵ CFU/ml	14%	3 >10 ⁵ CFU/ml saliva	58%	<p>Used these Infection hazard coefficients derived from these calculations.</p> <p>Beta for bacterial contribution to Lesion Development hazard rate = 0.3</p>
Mom’s MS Status	Infection Hazard Coefficient (i)	Probability of infection (i/35)																												
Not infected	0	0																												
Inf–no Lesions	1.8	0.05																												
Inf–WSL	2.3	0.07																												
Inf–Some Cav	4.0	0.11																												
Inf–Adv Cav	6.0	0.17																												
MS Score & Range	% infants infected																													
0 <10 ³ CFU/ml	6%																													
1 <10 ⁴ CFU/ml	16%																													
2 10 ⁴ 10 ⁵ CFU/ml	14%																													
3 >10 ⁵ CFU/ml saliva	58%																													
Toothbrushing effect on bacteria levels or plaque	<p>Tritten & Armitage (1996) — subjects 22–59, San Francisco. Plaque removal during toothbrushing:</p> <ul style="list-style-type: none"> • 17.4% manual toothbrush • 27.2% sonic brush <p>Sandström, Cressey, & Stecksén-Blicks (2011) Toothbrushing by 6–12-year-olds:</p> <ul style="list-style-type: none"> • Plaque Removal was poor and averaged 19–30%. 	<p>Multiplier used for relative amount of bacteria removed by brushing:</p> <ul style="list-style-type: none"> • 0.005 Less than 1 daily • 0.02 Once daily • 0.03 Twice daily 																												

Table 9. Input values for initial distributions, parameters related to disease progression. (continued)

Variable	Reference Information	Assumptions & Parameter Values										
Sugar frequency on level of bacteria or plaque	<p>Skafida & Chambers (2017). Found the brushing can only in part attenuate the association between snacking and sugar exposure on dental decay. Based on this concept the coefficients for sugar were slightly higher than those for brushing so that there is a tendency to grow even if brushing.</p> <p>Also, children who snacked all day instead of having meals had a higher chance of decay: OR = 2.32</p>	<p>Multiplier used for relative amount of bacteria growth by sugar frequency:</p> <ul style="list-style-type: none"> • 0.01 Low • 0.02 Moderate • 0.03 High 										
Fluoride varnish on lesion development	<p>Meta-analysis of fluoride varnish RCTs provided an OR of .61 95% (CI .57-.66) and subgroups</p> <ul style="list-style-type: none"> • low risk (LR: <0.50 DMFS/y), • medium risk (MR: 0.50-1.29) and • high risk (HR: ≥1.3). <p>Braun et al. (2017) children receiving ≥4 FV applications by age 3 had lower ECC prevalence:</p> <ul style="list-style-type: none"> • dmfs 16% reduction (3.5-fold reduction) • ds -28% reduction (7.7-fold) 	<table border="1"> <thead> <tr> <th colspan="2">Relative F exposure</th> </tr> </thead> <tbody> <tr> <td>1/year</td> <td>2.0</td> </tr> <tr> <td>2/year</td> <td>4.0</td> </tr> <tr> <td>3/year</td> <td>6.0</td> </tr> <tr> <td>4/year</td> <td>8.0</td> </tr> </tbody> </table> <p>Beta for FV effect on Lesion Dev't = -0.15</p>	Relative F exposure		1/year	2.0	2/year	4.0	3/year	6.0	4/year	8.0
Relative F exposure												
1/year	2.0											
2/year	4.0											
3/year	6.0											
4/year	8.0											
Fluoridated toothpaste frequency on lesion development	<p>Memarpour, Fakhraei, Dadaein, & Vossoughi (2015) showed a decrease in the size of WSL's with fluoride varnish at 4, 8 and 12 months with a -.74 mean change after 3 applications.</p> <p>Reported data found shows a decrease in dmfs and caries increments with use of F toothpaste. Few connect the amount of change to the frequency of brushing.</p> <p>Skafida & Chambers (2017) found an incremental association between a decreasing frequency of toothbrushing and higher chances of dental decay (OR range from 1.39 to 2.17)</p>	<p>A regimen of 4 FV/year will remineralize a WSL. The effect of fluoride decays after 3 months.</p> <p>Beta for effect of toothbrushing with Fluoridated toothpaste on lesion development: -0.2</p> <p>Relative terms for</p> <ul style="list-style-type: none"> • 0.25 Less than 1 daily • 1.0 Once Daily • 2.0 Twice Daily 										
Difference in rate of progressions in Child vs Adult teeth	<p>Enamel and dentin are thinner in deciduous teeth than in permanent teeth. From a diagram in Fejerskov's textbook enamel in permanent teeth look to be about 1.5 times the thickness of primary teeth and the dentine twice the thickness. (Fejerskov et al., 2015)</p>	<p>Coefficient ~ 1.2-1.55</p>										
Effectiveness of Motivational Interviewing	<p>Edelstein, Hirsch, Frosh, & Kumar (2015) derived a 63% reduction in caries incidence from Weinstein, Harrison, & Benton (2004). Weinstein found that those that received MI counseling had between 37% and 57% fewer lesions. Though this does not translate directly from counseling to an equal reduction in behaviors, reasoning that they have a 40% chance of improving their behaviors is within the reason of expectations given the results achieved to date on various experiments.</p>	<p>40% effectiveness in improving frequency of toothbrushing and reducing sugar frequency. Reported data does not link MI to behaviors but caries outcomes.</p>										

There were two types of information needed to calibrate the model:

- 1) those describing the prevalence and distribution of characteristics and behaviors in the population, and
- 2) data to inform the model's disease dynamics, i.e., the rate at which the disease progresses under various conditions.

The abstraction used for the caries lesion states posed a challenge for validating input parameters because most published data used either mean dmft/dmfs, dfs, ds, or some variation thereof.

Even so, few studies actually provide percent distributions of the population that fall in various comparable categories.

A note on randomness

One of the steps in building a model is to understand the role of random variation. Randomness may be present in the initial location of the agents, how agents are connected in a network, the properties of agents, and agent behavior. Randomness can be introduced when probability distributions are used to set up parameter distributions over a population of agents (Borshchev, 2013). In addition, when a simulation experiment is run, AnyLogic allows for the programmer to select the level of randomness used with either a random seed, which will produce unique and different simulation runs, or a fixed seed, which is initially random but is reused in subsequent runs and will produce the same results every time.

In this model, agents are spatially distributed within a grid based on whether they attend a pediatric or adult clinic (y-axis), and if it is traditional or risk-based (x-axis). Within their quadrant they are randomly distributed in space, but space does not influence agent behavior or decisions in this model. However, randomness in the assignment of initial agent properties could have effects on disease progression, and therefore the model. When patients are born, they are given an

appointment based on a uniform distribution between a minimum and maximum amount; which specific number they get is random. Many of the states are based on custom distributions designed to test calibrate the model, but there is still some randomness in the individual assignments based on those distributions. Furthermore, the combinations of various characteristics based on the probabilities of each property is not predetermined (as one might have to do in a Markov chain).

This model ran with a random seed, except when preparing a run for demonstration purposes when one might want to identify specific agents whose biographies provide good examples of dynamics one wishes to present. By running the model several times, one can see whether stochastics played a significant role and produced drastically different results. This was not expected to have too much influence given the relatively deterministic nature of this model and its action rules, i.e., it does not include learning and adaptation from the agent's perspective, and when the dentist responds to the risk of the patient, it follows a rules-based protocol.

When the models are initialized, they generally have a "warm-up period," the initial time period the simulation runs before starting to collect results. This is generally necessary for the model to reach a steady state, or one that mimics the actual conditions of the system. For example, runs are usually started with empty systems, no agents, no patients in the queues. This model has about a year of warm-up, after which time the distributions for the population are roughly correct and agents settle into their correct risk status. After a year, all agents are guaranteed to have their risk status updated at least once; this allows everyone to be properly assigned to a risk state.

Several iterations of the baseline model were run in order to aggregate and present averages across all the runs. For the scenarios, only a couple of runs were performed for each. I will first present the results of simulating the effect of a risk and disease management approach to caries

on the distribution of risk and lesion states in the population and then on the provider variables — total visits, visit types, and number of patients.

Graphical interface of the model

In addition to supporting graphical depiction of much of the dynamics that drive the behavior of the model, one of the strengths of AnyLogic software is its rich graphical interface during simulation, which helps the modeler reason through what is happening. The simulation interface allows users to interact and explore the model while it is running to investigate how it works and what might be behind certain patterns of behaviors. Three screens parallel the different levels of variables in this study: “main” shows population level information, “person” shows individual’s characteristics and disease states over time, and “clinic” shows the flow of patients through the clinic and the various types of visits. Figure 21 shows how one can visually appreciate the distribution of risk and lesions in a population, and how it varies based on the dentists they attend. Right next to this are the graphs showing the population level data.

- 1) The *main* screen (Figure 20) shows the population of agents as well as graphs of the population statistics. The outline of the agents indicates their risk level, the fill indicates lesions status. Therefore, a green agent with a red outline is one that currently has no lesions but is at high risk of caries. The grid is visually segregated by those that receive care at a risk-based vs. traditional care clinic. Patients in each quadrant attend the clinic in their quadrant.
- 2) The *person* screen allows us to look at the specific characteristics and journey of each specific agent. It displays their status with regard to each of the statecharts and variables. gives an idea of how one can inspect what is happening with specific agents in real time and follow them over the simulation (a larger version is in Appendix 4).
- 3) The *clinic* screen (Figure 22) shows the flow of agents through each of the clinics, and in each type of visit. The active clinic is highlighted, showing the numbers of agents flowing through each service block and type of visit. In addition, the unique number of patients overall and in the current year are displayed.
- 4) Furthermore, there is a graphical interface to run the simulation experiments that allows for parameters to be modified to test sensitivity to these changes in the model and has a selection of predefined experiments (Figure 23).

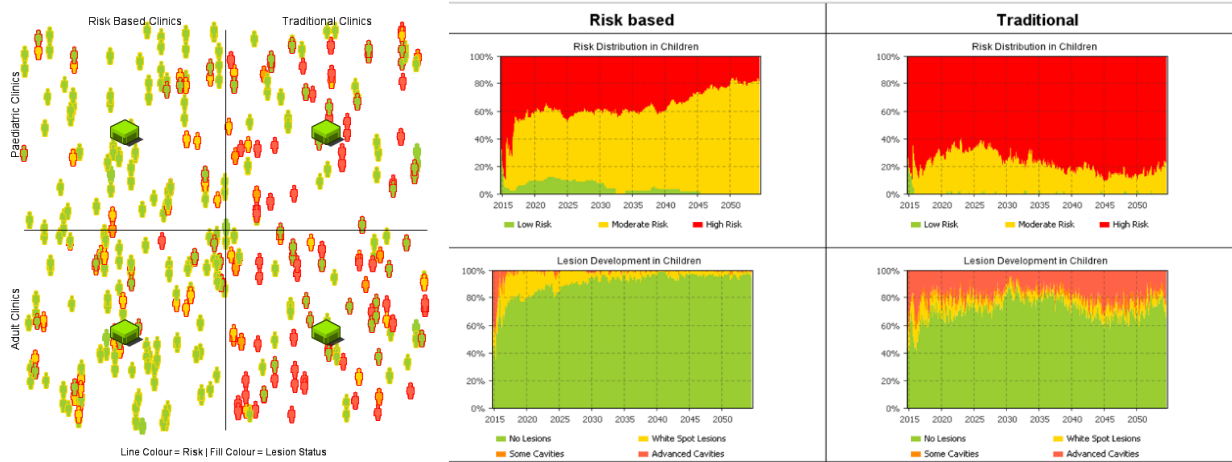

Figure 20. AnyLogic main view during simulation

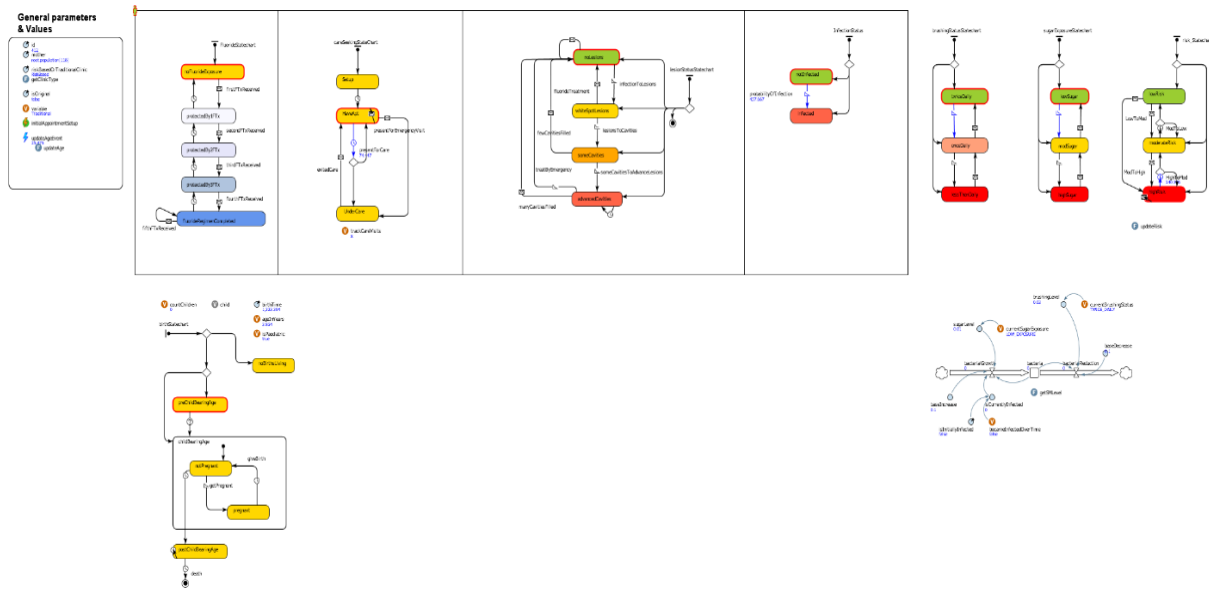

Figure 21. AnyLogic View of person screen and associated statecharts when model is running

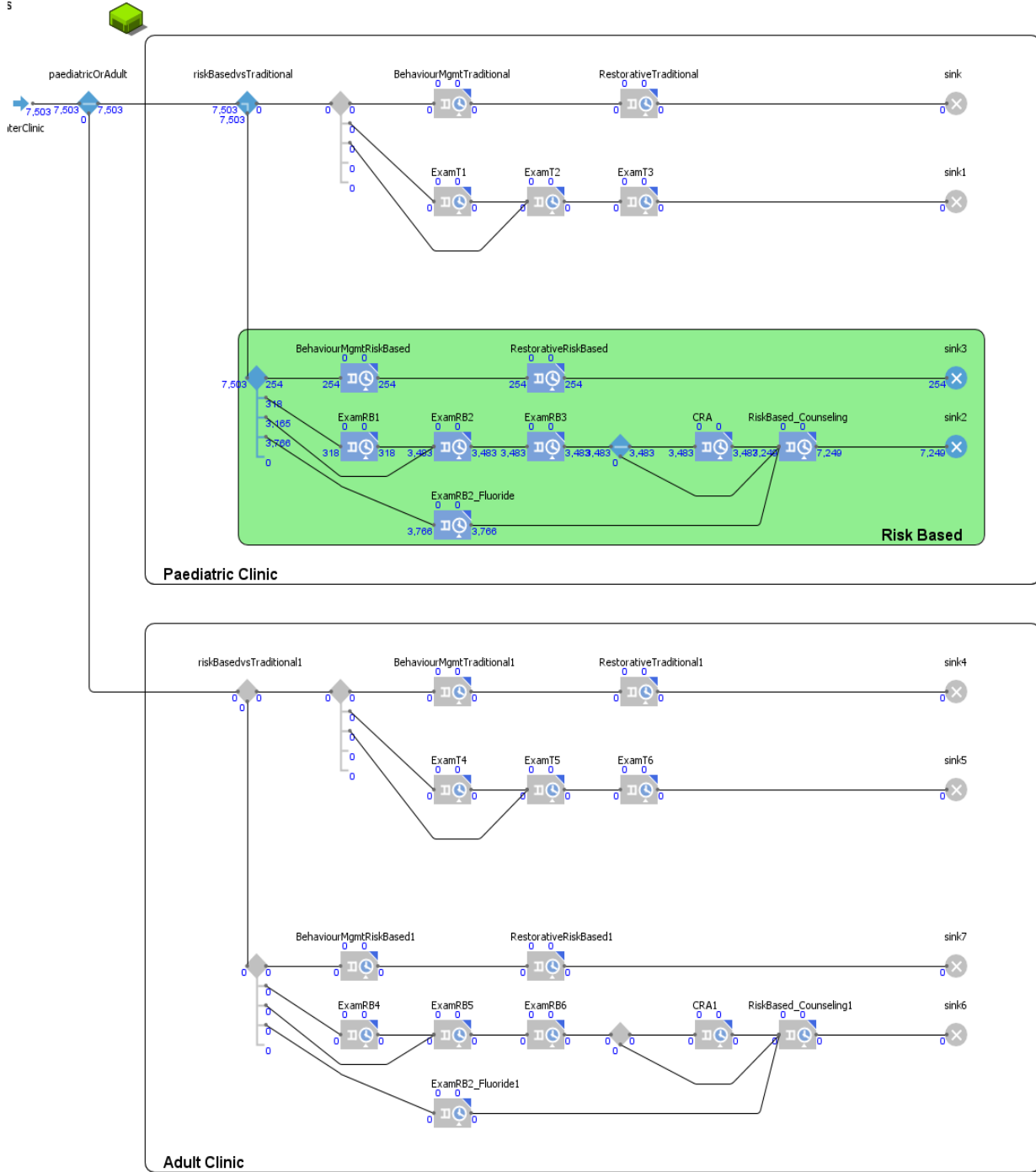

Figure 22. AnyLogic View of simulation model clinics view during simulation

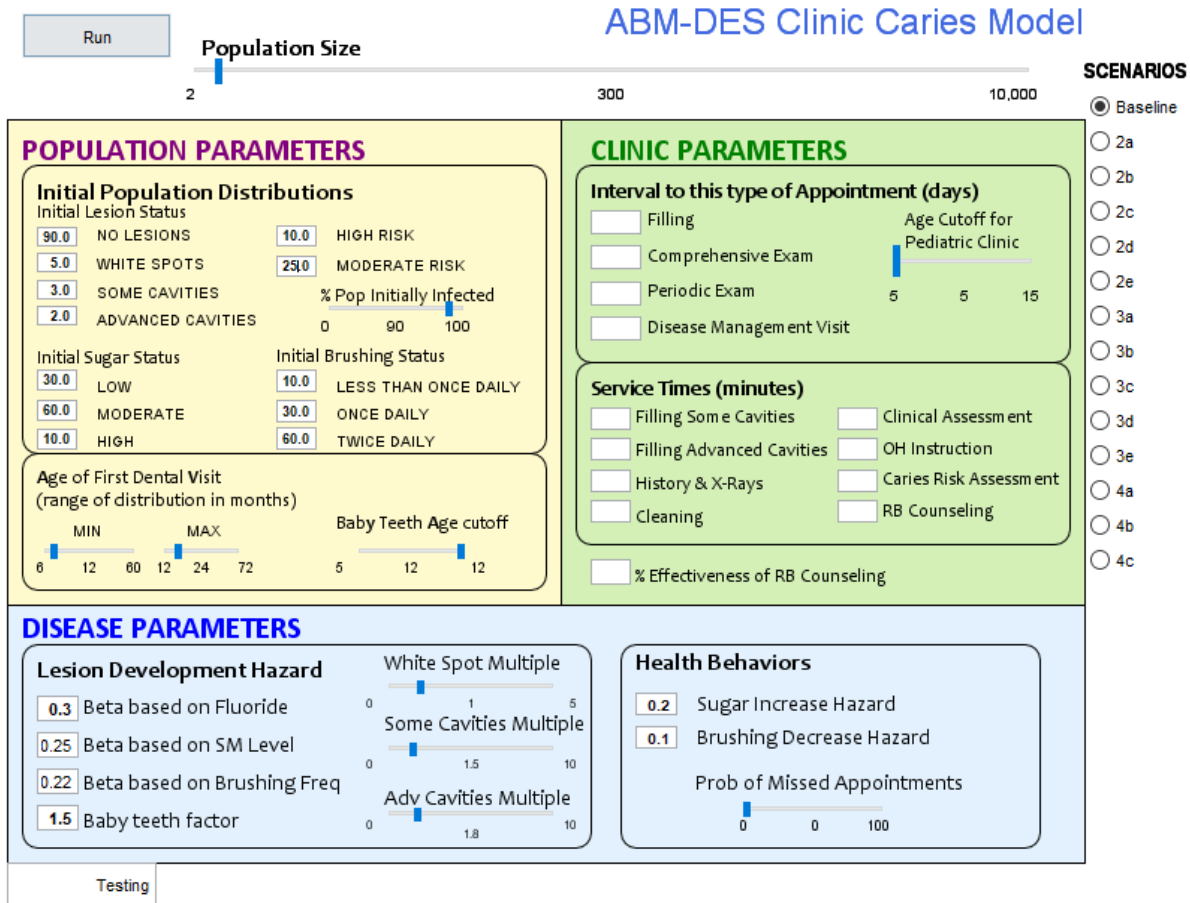

Figure 23. AnyLogic Simulation experiment screen

Model Verification, Calibration, and Validation

Simulation models can often yield unexpected or counterintuitive results. For this reason, researchers need to work to internally (verification and calibration) and externally validate the model. The process for choosing parameter values is referred to as input validation and calibration. This is not a sequential or linear process at much as an iterative process that includes verification, calibration, and validation, as illustrated in Figure 24. Verification determines whether the simulation model accurately represents the conceptual model, i.e., “Did we build the model right?” Validation, an often more challenging step, is the process of determining if the

model and associated data are an appropriate representation of the real world, given the model goals, i.e., “Did we build the right model?” (M. L. Loper, 2015)

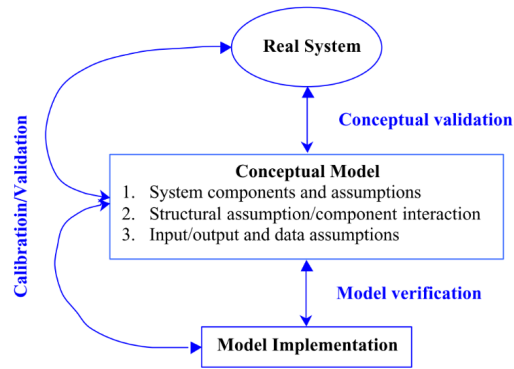

Figure 24. Illustration of verification, calibration, and validation

Verification is the process of checking that we built the model we wanted and it functions as we

expected. The iterative model building process includes exploring the behavior of the system as you build it in order to understand the structure and the system response to various assumptions and under varying conditions. For example, when we added the SD model to represent the bacteria levels and the opposing effects of sugar frequency and toothbrushing we verified that the stock of bacteria varied based on the relative amounts of sugar and brushing.

Calibration is the process of tuning model input parameter to align with basic patterns observed in the real system being modeled, also referred to as input validation (Teshfatsion, 2018). *Input validation* refers to the use of parameter values that come from external knowledge of micro-behavior, such as information about the course of disease in a single individual. The parameters of a model describe different parts of the model, including the course of the disease in a given host, the intergenerational transmission model, how risk and protective factors interact, and the effects of care and visit intervals. The aim of calibration is for either a qualitative match or a close, quantitative match (Auchincloss & Garcia, 2015).

Calibration is important in that it can increase credibility in the model’s ability to emulate real-life behaviors or its ability to study emergent behavior based on empirically accurate

dynamics. The model conceptualization explicitly articulates how the structure and decisions generate behavior in the model. A good dynamic conceptual model links observable patterns of behavior to micro-level structures and processes, and the outcome of the modeling process should be increased confidence that “the model represents the structure of the problem situation, and that the structure is responsible for the observed behavior” (Oliva, 2003). Once achieved, it is possible to proceed with the exploration of policies, interventions and scenarios.

When no calibration data exists, one can aim for a broad alignment of parameters with the literature on the topic. Quantitative matching is usually chosen when particular parameters strongly affect the model results; they are thought to have independent effects on the model and good data exists. However oftentimes the data is not available, and then we compare the results to common sense or our own heuristics, which can then be further calibrated as data becomes available.

To calibrate and understand how the lesion development hazard would respond to different betas, multipliers and input terms, and the transition times that would result from them, I used Excel and tested out different scenarios (see Table 11). For example, I started with a very high-risk scenario with high bacteria levels, but not fluoride or brushing, for a child. This would represent what we would expect to be the fastest transition times. Then we added the first level of brushing — this was also a high-risk case.

For my model, the most difficult aspects that required parameter definitions were the effects of individual behaviors related to sugar, toothbrushing, and effects of fluoride on lesion development. Although there is extensive research on fluoride, bacteria levels, sugar, and resulting dmft or dmfs states, few studies report individual trajectories relative to these factors, or combinations of factors. Also, given the level of abstraction for caries in my simulation model, it

was difficult to calibrate to studies that use the number of decayed, missing, filled teeth or tooth surfaces (dmft or dmfs). The Cariogram is one tool that has been used to predict risk (Hänsel Petersson, Åkerman, Isberg, & Ericson, 2017; Petersson & Twetman, 2015). I contacted Dr. Hänsel Petersson for information about their algorithm as an option to calibrate input or output parameters, as there have been a number of validation studies on their tool. However, while the response included a thorough explanation of the general logic of the algorithm and how it was derived, given that it includes 5 million combination of factors, they can really only be seen in the program. It therefore did not produce information helpful for calibration.

Therefore, calibration for some factors occurred at a qualitative level. This was one of the most challenging aspects of developing this model, and understanding which aspects were most critical to “get right” for the validity of study. But as is often the case, this process unveiled areas of the model for which it is difficult to extract parameters from the available empirical evidence and suggests areas for future research inquiry. It also points to another area of skill development required for simulation modeling: translating data from survival analysis, time to events, competing risks to information that can be used for calibrating coefficients determining rates of transition between stages or combination of states.

There were two parts of the model that were particularly critical and difficult to calibrate: the bacterial level SD model and the lesion development hazard. For the bacteria level there are parameters (in Main) or coefficients that translate how each level of sugar exposure or daily toothbrushing affects the “rate” of growth or reduction of bacteria respectively. See Figure 25 below. This required translating how frequency of sugar maps to bacteria levels, and what effect brushing has on removing it.

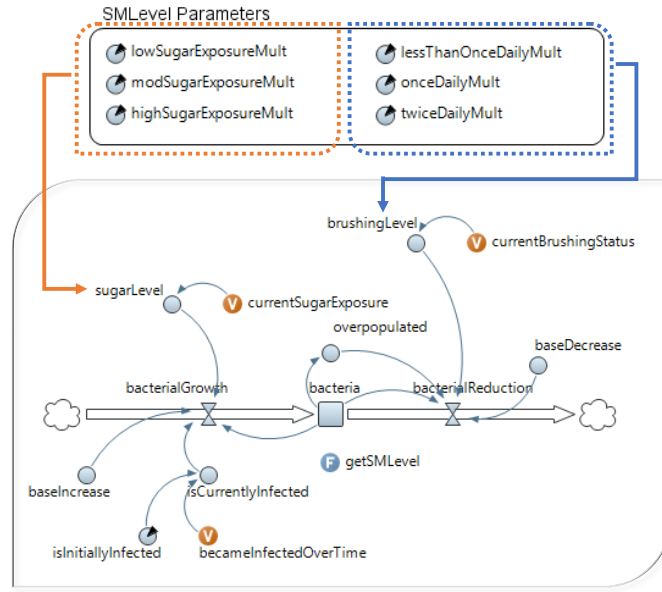

Figure 25. Parameters determining bacteria level that were calibrated

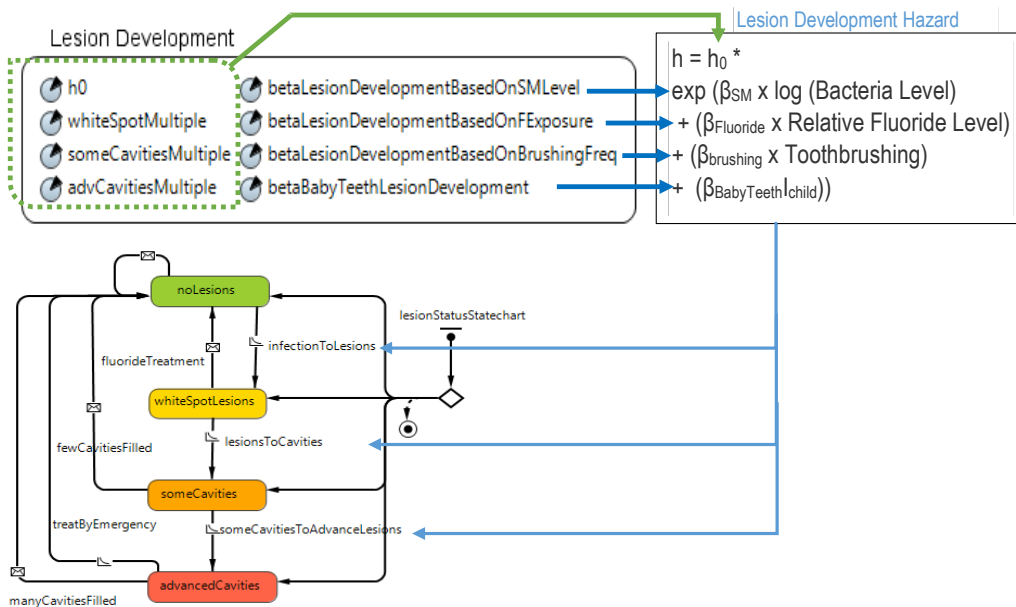

Figure 26. Parameters informing the lesion development transition rates that were calibrated

Based on Berkowitz’s levels of *S. mutans* bacteria ranging from less than 10^4 to 10^6 colony forming units/mL, I ran the model and varied these factors until the resulting amount of bacteria was within the range of these levels. This process highlighted the need to understand the relative

Table 10. Sugar exposure and toothbrushing frequency multipliers

Sugar Exposure State	Sugar Multiples	Toothbrushing State	Brushing Multiple
Low	0.01	< Once Daily	0.005
Moderate	0.025	Once Daily	0.02
High	0.35	Twice Daily	0.03

contribution of these two factors. This SD model refers to the mechanical effect of toothbrushing, and it was assumed that the effect of brushing in reducing bacteria was not equal but less than the effect sugar can have on growing bacteria. Therefore, the expectation is for example, that someone at moderate sugar and brushing once daily, will have a slow increase in the amount of bacteria. Even with these placeholder input parameters we could verify that the dynamics were being represented as conceptualized, and bacterial levels moved as expected.

The second aspect of the model that was calibrated was the lesion development hazard rate which informs the transitions in the lesion state chart (Figure 18 on page 175). The beta coefficients included in the lesion development hazard formula had to be calibrated as well as the lesion coefficients for each state. The betas can be thought of as the relative contribution of each factor towards the rate of developing lesions, and the multiples are coefficients that determine the differences in the rates of lesion progression based on an agent's current lesion state. So for example, all else being equal, it may take longer for someone that has white spot lesions to develop cavities than for someone who has no lesions to develop white spot lesions. Figure 26 (on page 197) depicts what parameters inform the lesion development hazard rate, and what transition rates this hazard rate informs in the lesion statechart.

This was calibrated to published information on transition rates (Arrow, 2007; Mejàre et al., 2015; Shwartz, Gröndahl, Pliskin, & Boffa, 1984; Tickotsky, Petel, Araki, & Moskovitz, 2017;

Warren et al., 2010). There was some but limited information about differences in transition times based on an individual's risk, but a few values was helpful to calibrate, and particularly to get a sense of the differences in progression between earlier states and later states. Initially I thought progression got faster as disease progressed, but these reports provided evidence to the contrary. Then I tested this same situation but with a low bacterial load; then the lowest risk situation: low bacteria, high fluoride, twice daily brushing, and assessed whether those transition times were realistic or in range of published transition times. Transition times were hard to come by or translate from existing studies that generally all used dmft/dmfs (or DMFT/DFMS).

Table 11. Excel table used for calibration of lesion development hazard coefficients

CHILD - high risk				
	base hazard rate coefficient by State	Transition Rates	rate in months	rate in years
From No lesion	1.2	3.996	3.0	0.3
From WSL	0.7	2.331	5.1	0.4
From Some Cavities	0.5	1.665	7.2	0.6

	Beta	input	hazard term
bacteria	0.3	10,000,000	2.10
fluoride	-0.15	0	0
brushing	-0.2	1	-0.2
primary teeth	1.2	1	1.2
Base Hazard		0.15	
Lesion Development Hazard =			3.33

AnyLogic has a more sophisticated way to do this calibration but this process was helpful to get a sense of the contribution of the various betas and factors to the process and model behavior, and how parameters translate to the rate at which agents moves between states. Additional calibration tables are listed in Appendix 5.

Blume (2015) discusses the question “What does it mean to have good parameter estimates?” and goes on to explain that since the purpose of ABMs is to study emergent behavior of a system, validation poses a tension between different ways of “getting it right.” Blume states: “An empirically successful ABM will get the micro-behaviors right, so the agents in the model approximate in some useful way the behaviors of agents in the world. The ABM will also accurately describe the macro-behaviors, the emergent properties. That is an enormous undertaking for any large-scale computational model.” He goes on to say that “in principle, one would get right both the micro-behavior and the macro-level behavior, but this may be impossible.”

Often the modeler has to make a choice. In my model, the micro-behaviors of individuals and their disease progression seemed most critical to the study, and the buy in of dentists. The macro-behaviors, the distribution of risk and disease in the population can vary across populations. In this model, I am not trying to emulate real-world distribution as much as test how different distributions impact the operations of a dental practice. The micro-behaviors, however, are how the impact is transacted, so they have to have a level of credibility. I evaluate the plausibility of input parameters that determine disease progression and agent behaviors by drawing on not just published literature, but when enough detail is not available, I also use my own heuristics, and other evidence such as case studies and practical experience of experts in the field.

Validation to external data sources for this model is appropriate for population characteristics (risk, disease, toothbrushing and sugar behaviors) as well as of the dentist’s operations. However, the important aspect of this simulation model is that it incorporates aspects of the disease and dental practice that the clinical practitioner can relate to, and at the same time

the aggregate population patterns that result are realistic enough for the epidemiologist or population health professional. In the spirit of transparency, Table 3 lists our model assumptions. Intermediate clinical outcomes of the model can be compared with those observed in experimental or observational studies (external validity). For example, what are the frequency distribution of toothbrushing, sugar frequency and bacteria levels? I can also compare “caries experience” or more accurately “cavity experience” to published prevalence data for different age groups (2–5, 6–8, 9–11). As an initial pilot not all of these validation steps were implemented but are left for future development and analyses.

In the end, however, the value of this model is to offer an initial framework with which to explore relationships and dynamics that can be calibrated. Epstein explains in his article “Why Model?” that when challenged whether he can validate his model, his response is often “Can you validate yours?” The benefit with simulation models is that assumptions have to be made explicit so that we can study what they entail, and what happens when you change them. Therefore, a model can, in principle, be calibrated with data. This is more difficult to do with implicit models where the assumptions are hidden, their internal consistency untested, and their logical consequences and relation to data unknown (Epstein, 2008).

Model testing

Model testing is an ongoing part of the modelling process. One way this was done was to trace an agent through the simulation and see if their characteristics warrant the types of outcomes. So for example I would be surprised if someone who was low risk, consumed low sugar, and brushed twice daily progressed to higher levels of lesions. If so, I would track that individual to try to understand what might have caused the lesions to develop.

Another way is to see if I can break the system. Are the lesion states consistent with risk assignments? On occasion we added “test buttons” that allowed us to force the system to check on a status more often than it would naturally check, allowing for trajectory verification. At one point, we realized agents were moving into “advanced cavities” too fast. In the debugging process we found that messages were not being sent and patients were not going back for follow-up appointments and care; they never improved their behaviors and thus lesions advanced in severity with no chance of treatment.

I ran the model with a variety of extreme scenarios to compare the outcomes with my prior expectations (internal validity) and asked, How does change in behavior (toothbrushing, sugar eating, etc.) change lesion development status? How does going through the DES change their status? Are they scheduled appropriately? How many DM visits will it take to change lesion status? Do white spot lesions get remineralized? Is risk status consistent with other states?

During the testing I noticed the model was not initializing with the risk profile given by the parameters. In examining how the model was initialized, it became apparent it was an issue of joint probability distributions and the order the system assigned the different parameters. This meant I had to make adjustments in the values for the initial distributions of risk and lesions in order to produce the desired functional distributions in the population. See Appendix 6 for the calculations used to compensate for this issue.

Design of Experiments

For all experiments, the model will produce output for both population and provider outcomes. Table 12 describes the baseline parameter settings, and the three groups of sensitivity analysis with parameter variation.

Table 12. Description of Scenarios Examined

Ref #	Scenario	Sensitivity parameters		
		Age 1st Visit	Risk Profile (%H – %M – %L)	Compliance
<i>Risk-Based vs Traditional</i>				
1	Baseline	1–6 yrs	10-25-65	100%
<i>Age of 1st Visit</i>				
2a*	1st visit, 1–2 year	1–2 yrs	10-25-65	100%
2b	1st visit, 2–3 years	2–3 yrs	10-25-65	100%
2c	1st visit, 3–4 years	3–4 yrs	10-25-65	100%
2d	1st visit, 4–5 years	4–5 yrs	10-25-65	100%
2e	1st visit, 5–6 years	5–6 yrs	10-25-65	100%
<i>Initial Population Risk</i>				
3a	Very Low	1–6 yrs	5-25-70	100%
3b*	Low Risk	1–6 yrs	10-25-65	100%
3c	Moderate	1–6 yrs	15-25-60	100%
3d	High	1–6 yrs	50-25-25	100%
3e	Very High	1–6 yrs	70-25-5	100%
<i>Patient compliance</i>				
4a	Low	1–6 yrs	10-25-65	25%
4b	Moderate	1–6 yrs	10-25-65	50%
4c	High	1–6 yrs	10-25-65	75%

*Same as Baseline settings

Scenario 1: Baseline Compares a risk-based approach to care to a traditional one-size-fits all approach in a best case scenario that includes perfect compliance with visits by patients, care is initiated between 1 and 6 years of age, and a risk distribution similar to what might be an average in the US population.

Scenario 2: Sensitivity to Age of first dental visit Lack of access to care early in life might affect the ability of dentists to apply preventive and caries control measures and prevent disease or need for surgical interventions. Therefore the assumption is that the older the child is when they access care, the more advanced the disease can be. This is expected to have a greater effect on a risk-based care operation, as it will add to the treatment, and allow disease to establish itself. Edelstein et al. found that intervening early was a more cost effective approach than interventions targeting high risk populations (Edelstein et al., 2015).

Scenario 3: Sensitivity to initial population risk This scenario is an important *raison d'être* of the model. One way to test whether efforts of a dentist to reduce disease among patients, can change how the feedback from implementing a risk-based approach to care can be assessed. Some initial categories of population risk have been selected. However, initial results of the model might inform future tests based on how the population risk changes over time. Another simulation can be tested with different population distribution.

Scenario 4: Sensitivity to patient compliance with return visits The likelihood of patients returning for their scheduled appointments is a challenge that dentists face every day, especially those serving low-income populations. It also has the potential to minimize the effectiveness of the risk-based approach, due to lack of fidelity to the protocol intervals. This measure is determined by a probability that the agent will miss their appointment. If it is missed, the model will provide another appointment of the same kind as they missed.

Simulation Execution and Data Analysis.

Analysis consisted of 10 iterations of the baseline scenario and one or two for the sensitivity tests. Data was either directly exported or manually extracted from the time stack charts in AnyLogic into in Excel 2016 for further analysis. AnyLogic produced some graphs in the simulation including the time stackcharts¹⁰ of risk and lesion distribution in the population, and line graphs on clinic productivity measures. Analysis and learning also occurs in real time while the model is running, and observations were noted about the model structure and behavior.

10. Time stackcharts are basically histograms with stacked bars; there is no space between the bars to illustrate the continuous nature of the data over time.

Chapter 5. Results

Modelling is both an explorative learning process as well as a results-driven process. As such, one of the benefits of a dynamic models is derived from the modeling process itself, not just the resulting model. From developing a system map I learned some of the language of system thinking and how to see and characterize dynamic relationships and to illustrate them with proper technique, to identify feedbacks and loops make my assumptions explicit, to take them out of my head so that others can see them, critique and add to them. From the simulation model process, I learned what the “iterative process” was of testing and calibrating the model and learning how it responds to certain parameters and conditions. While the goal here was to demonstrate the utility, we used questions to do that, and the data produced gives a good indication of how these questions could be answered. Along the way we are trying to learn about the system, test assumptions, identify erroneous logic, and understand the processes built into the model and the output patterns that emerge from it. These are skill are learned by doing, and practicing.

This chapter describes first the results of the causal loop diagram exercise and then the results of the hybrid simulation model development process, the model developed and some examples of the results it produced, along with some lessons learned. I have attempted to be explicit about the decision-making process during the model development, noting where decisions were made. Data is generated by AnyLogic during the simulation, along with time stack charts showing distribution of risk and lesions in the population, line graphs of number and types of visits, and volume of patients. As needed data was exported by AnyLogic or was manually exported to Excel 2016 for further analyses and visualizations.

Causal Loop Diagram

A series of causal loop diagrams resulted from the system mapping exercise. It captured feedback relationships and interactions I understand to have an influence on U.S. dentists' practices in the delivery of dental care and population oral health. They also illustrate relationships that might have relevance to the slow adoption of effective preventive and disease management techniques in dentistry and may offer insight into system levers to improve oral health and reduce cost. The ultimate reason for looking at what influences dentists' practices is the oral health of the population which is illustrated in the stock and flow diagram in Figure 13 of the methods section (page 158). The causal loop diagram is built around this basic structure. Five general themes emerged from the final structured causal loop diagram in Figure 28 on page 213.

- 1) The effects of risk and disease management versus restorative care on prevalence and severity of disease in a population.
- 2) Training and capacity to provide risk-based care versus restorative.
- 3) Financing of dental care.
- 4) Patient experience and demand for care.
- 5) Upstream improvements of healthy lifestyles.

This is a participatory exercise; there is a story and explanation behind each of the links depicted. I will not provide an exhaustive explanation for all the parts of the diagram, but will provide a streamlined description of the themes to demonstrate the value of system mapping.

1. Risk and disease management versus restorative care

What stands out here is how risk and disease management can reduce or reverse each inflow into more severe stages of disease while restorative care only intervenes at the final stages of disease only to return individuals to an earlier stage of disease. While restorative care does little

2. Training and capacity to provide risk-based care versus restorative

“We practice the way we’re trained” and “We train the way we practice” summarizes the set of reinforcing loops that relate to this theme. Dentists are more likely to practice the way that they have been trained, which produces a bias against change in professional practice. Furthermore, because being part of the profession entails giving back and training the next generations, practicing dentists are often part of dental school faculty supervising dental students and residents. They are likely to teach what they were taught, thereby reinforcing the importance and influence of training. This suggests several pathways whereby training is reinforced

The emerging literature on the important role of habit in clinician practices and treatment decision making suggests the context of behavior formation can affect how behavior responds to change, and that in familiar and unvarying settings, behavior tends to be guided more by habit than intention (Nilsen et al., 2012). This points to the importance of the training of dentists for how they will make decisions later in their professional career. Which loop is reinforced will determine whether the restorative or disease management one will in turn be reinforced.

3. Cost and financing of dental care

“We do what we can get paid to do, and don’t do what we can’t get paid to do” summarizes this theme. The other part is that training programs are also under financial constraints.

Insurance companies and public programs have two mechanisms to control costs: reduce reimbursement rates to providers or reduce the scope of procedures that are covered. For example, Medicaid pays dentists to apply fluoride varnish only twice a year for children; and

children are known to be at moderate to high risk for caries by the mere fact that are Medicaid recipients. Many states have reduced reimbursement rates to the point where these agencies cannot guarantee the appropriateness of the provider network.

Since complex surgical or restorative procedures require more skill and often time, they are accordingly generally reimbursed at higher rates making them more appealing for dental businesses. However reimbursement schemes in many states still do not align with professional guidelines for protocols for risk and disease management creating less of an incentive for these procedures. This is a reinforcing feedback loop in that the more we restore and do not prevent, the more disease there will be that needs to be treated; more complex treatments cost more, making less funds available for prevention. As this process reinforces, it reduces the use of risk and disease management. Furthermore there is ample evidence that reimbursements drive practice. While a school clinic is an ideal environment to engender best practices, dental school clinics are under pressure to generate revenue just as practicing dentists are and thus, as with practicing dentists, financial concerns often drive practice decisions at dental school clinics

4. Patient experiences and demand for care

Short- versus long-term rewards, benefits, and measurable outcomes of services. The observable effects of restoring a cavity are immediate and rewarding for both the dentist and the patient; outcomes and rewards of risk and disease management, on the other hand, involve delays and no one gets rewarded for preventing fires that never happen. Caries has historically not been treated as a chronic condition; but the fact that there are subsequent cavities to fill should come as no surprise to an informed practitioner, especially if they are cognizant of the patient's eating and toothbrushing habits.

The rewards are reaped over a longer time horizon, and it may be difficult to directly associate a positive outcome with anything the dentist or patient did, or even worse, with what the patient did not do. This dynamic creates a challenge for policymakers and administrators of insurance and public programs who develop the payment systems. It is much easier to assess the value of restoring a cavitated tooth than the longer-term value of preventing one. This is also true from both the dentist's and the patient's perspective. The dentist can observe the fruit of their restorative service; the patient can see what he paid for, but they are not cognizant of the counterfactual, what could have happened thereby underestimating the value of education and counseling because of the delay to outcome, or unobservable outcomes.

Supply creates Demand “How we practice trains the public on what they could or should demand” summarizes this theme. Information asymmetry emerges because patients do not have enough information to evaluate the extent and quality of the services offered; and the dentists, serving a dual role to act as patient advisor and to offer services, have considerable influence on the type and quality of services offered (Grytten, 2017). Financing, training, and capacity of providers all have an influence on norms of the profession and the potential for supply-induced demand. There is feedback between patients demand or acceptance of the services dentists offer and recommend, but also dentists response to what they perceive patients want. Though research has not fully clarified where the process starts, given the information asymmetry in dentistry, it is less likely that it starts with the patient

There is some evidence that patients' interest in prevention might influence a dentist's practices, however. Because much of the data is cross-sectional self-reported survey data the direction of influences is often not clear. Studies find the percentage of patients interested in caries prevention significantly associated with whether a practice recommends in-office fluoride

application to 50% or more of patients; other studies find that dentists' ratings of patients' preferences for preventive care are strongly related to whether they themselves provide preventive services (Yokoyama et al., 2013). What appears to be at play here is that this is likely a mutually reinforcing relationship leading to doing more of what we do.

Upstream improvements of healthy lifestyles

Trueblood (2008) has provided evidence that the families of pediatric patients are receptive to caries-related education and that parents' interest was not associated with socioeconomic status. A public-health approach of targeting the causes of disease is fundamentally better than being able to deliver the most effective and economical treatment. In concept, if we could identify those who are more prone to developing conditions, then prevention could be targeted to those most at risk, producing the best health outcomes at a lower cost (Hirsch et al., 2005).

It is helpful to view the health promotion role of public health and other community interventions in context of the disease and dental care process and their potential to intervene in health habits as well as to increase the demand for preventive and disease management services. What might be lost at this level of representation is that the effect of dentists targeting risk and disease factors at the same time public health interventions are targeting these behaviors could have more than an additive effect, i.e., there may be an important interaction when messages and practices are aligned.

For caries, efforts to improve oral hygiene habits of families, reduce frequent consumption of sugar-sweetened drinks and snacks, and eliminate the host of caries-causing bacteria that could be transmitted to vulnerable young children would help reduce the movement of people from healthy to at risk. Since social determinants of health such as education, income, better workplace policies that support families, other efforts to improve living conditions and housing,

are common to caries and other conditions, there might be cost-savers when the downstream care costs of prevented illness are taken into consideration (Hirsch et al., 2005) “However, one problem is that studies of this nature take a long time to reveal or confirm the health protection benefits of these types of efforts, and they are often dependent on context — thus efforts that work well in one area do not necessarily transfer well across regions or localities” (Hirsch et al., 2005).

Though additional input is required regarding relationships and links, following are three initial potential leverage points that emerged from the exercise:

- *Risk and Disease Management* for its ability to influence many steps in the progression of disease
- Training of dentists has potential for leverage, given the associated cascade of reinforcing feedbacks linked to it that it can influence: which procedures and practices dentists feel comfortable with and better prepared to do, and therefore how they will practice; and how they will train dental students when they become teaching faculty members
- Innovative financing strategies are needed to support and incentivize dental schools so that dentists have exposure to ways of practicing that emphasized prevention and disease management. Creating these habits can shape the practice of dentistry towards one of minimally invasive dentistry, with an emphasis on addressing the causes of caries and not just the consequences. Even if reimbursements are not aligned, practices are in place and might have other influences on the system.

Hybrid Simulation Model — Model Building

Modeling the progression of caries disease

The hybrid simulation model developed for this project models the progression of disease in a population of children and adults through endogenous biological and behavioral factors including infection, oral hygiene, sugar exposure, and care-seeking behavior. The model makes some assumptions especially about the patient's behaviors in order to control the level of complexity, and allow for initial understanding of the system. For example, individuals do not decide on their own whether they want to make an appointment to see the dentist, or whether they will go to an appointment — we decided (in the baseline) everyone gets an appointment and everyone goes to it. While the model has some deterministic aspects, its ability to illuminate system dynamics is not diminished. The model development process helped to clarify the two homeostatic processes important to the development of caries — microbial homeostasis and mineral homeostasis— and attempts to illustrate these two interrelated processes. The microbial homeostasis represented in the system dynamic model as a stock of bacteria that grows based on the amount of sugar exposure, and removed based on the amount of toothbrushing. The mineral homeostasis is captured in the lesion development hazard rate, which includes the protective effect of fluoride (both from toothpaste and fluoride varnish) working against the amount of bacteria (plaque) in the mouth and on the tooth. The ability to outline these processes helped conceptualize the various interactions that results in caries disease in order to simulate them. The number of factors used to determine the rate of lesion progression was limited to facilitate learning and calibration of a pilot model. The fluoride varnish aspect depends on care-seeking.

Ongoing calibration can be a never-ending process, but an important part to calibrate for this model were (1) the transitions characterizing the rate of infection with the cariogenic bacteria,

and (2) the rate of lesion development. The difficulty in this process was finding the right data to calibrate it to, or extrapolating rates from prevalence, incidence, or even survival data. Even when researchers used longitudinal data to answer their research questions, data is often reported at the group level at different data points, rarely providing progression rates or ranges.

Descriptive statistics from a baseline simulation are presented in Table 13. These statistics describe the rate of progression of the disease that resulted from the various parameters and initial distributions. It took on average 2.6 years for an agent to develop white spot lesions, and another 2.3 years for those lesions to develop into cavities; on average over about 5 years for a cavity to develop. This results, even though the age of initial infection is relatively early, in a mean of 5 days and a max of 17. This might be quicker than one would expect in real life, but it is conceivable that infants exposed to a mother with high loads of bacteria will acquire it at such a young age. Most agents do not develop white spot lesions before the age of 3 years, although about 17% do.

Table 13. Population health descriptive statistics from baseline simulation (in years)

	Mean	Median	Min
Time To Lesions (from No Lesions)	2.60	0.14	0-17
Time To Cavities (from WSL)	2.33	0.26	0-13
Total Time to Cavities (from No Lesions)	4.93	0.41	0-30.3
Age of Initial Infection	0.02	0.01	0-.05
Time Spent with Some Cavities	0.58	0.29	0-4
Time Spent with Advanced Cavities	11.13	0.64	0-66.9
Total Time with Cavities	11.71	0.94	0-71.1
Time in Low Risk State	0.07	0.00	0-11
Time in Moderate Risk State	6.68	0.33	0-35.5
High Time in High Risk State	12.79	11.84	0-35.5

*0.02 years = 6 days, 0.01 = 5 days, and 0.1 years = 36 days

The prevalence of white spot lesions is rarely reported in the literature, and the time it takes for them to first appear is rarely known, making it hard to compare this rate to population rates. If we consider that NHANES reports that 23% of 2–5-year-olds had caries experience (Dye et al., 2015a) (measured at the cavity stage), this rate of WSLs before age 3 appears to be in an acceptable range. On average agents spend almost 12 years with cavities over their lifetime, and almost 13 years in a high-risk state. Since most individuals experience caries in their lifetime and cavities generally progress slowly (if the individual is not a young child), this could be a reasonable amount of time for someone to have some enamel cavities and even some dentine cavities. The fact that it is half a year for some cavities but 11 for advanced, suggests the model requires some further calibration.

Modeling the dental care process at a pediatric dental clinic

The model simulates a typical or stylized dental care process at a pediatric dental clinic for both a traditional clinic and one that uses a risk and disease management approach. The differences included between a traditional and a risk-based care process are conservative in an attempt to not unduly prejudice the traditional care process; some of them are small differences designed to have an impact through the accumulation over time.

The clinic process represents services that pertain to patients and their disease, distinguishing between comprehensive (12-month) and periodic (six-month) exams, and for risk-based clinics, a disease management visit in which agents can receive fluoride and risk-based counseling. The main services that characterized these processes were included in order to simulate the parts that were similar as well as those that would change with the implementation of a risk-based protocol. The variable for time required for behavior management based on an agent's age (to account for young children's difficulty sitting and cooperating with procedures)

allows for some randomness and variation in the visit times. However, the varied scales of the model that includes time for disease to progress, as well as the small scale of a short dentist visit, sometimes makes it difficult to appreciate time use at the clinic. It does, however, reflect the scale of time individuals spend at a dental office compared to the time outside a visit where the dentist has little influence on behaviors.

The scheduling intervals were an important difference between clinics. It was expected to have significant impacts on productivity and busyness, and to the extent that resources were not accounted for, the model might not reflect the true extent of these differences. In particular, the lack of resource constraints allows the risk-based clinic to accumulate more visits than a traditional, without regard for its capacity.

Because the focus of the analysis was on children, the focus of model calibration was towards the pediatric population, sometimes at the expense of oversimplifying the adult clinic care process and disease progression calibration. The dental process for adults can involve more complex and greater variation in the types of procedures performed. In order to overcome this limitation of the model, the data is most often reported separately for pediatric and adult. A few variables such as lifetime days of cavities includes both and should be treated with that limitation.

Since this is a pilot model, during the development process the decision was made to not represent clinic resources in detail, but to first assess the effects of interval schedules and disease at the clinic level, then later elaborate by incorporating specific clinic resources such as numbers of dental assistants, dentists, chairs, or space used. In addition, in learning the extent of programming required to build a simple dental clinic schedule to constrain capacity, it was decided that adding a more realistic scheduling aspect was outside the scope of this dissertation

and left for future model enhancements. Therefore, some limitations resulted in the external validity of the productivity variables (number of visits and patients by time) and our ability to calibrate the results to real pediatric dental practice production levels. That said, the relative volume of visits, types of visits, and patients over time seen within a practice and across types of practices is more important than the specific number of visits a clinic has in a day or month. The model timeframe is in days, and appointments can happen at any time of the day.

Modeling the interaction between the dentist and the patient

The clinics (i.e., dentists) appear to be following the formulated clinical protocol for their clinic and per the characteristics of the presenting patients. Both traditional and risk-based clinics provide exams, cleanings, fluoride treatments, and restorations and document them in the agent's history. In addition, the risk-based clinics do CRAs, provide risk-based counseling using motivational interviewing and self-management goal setting; this helps agents improve their behaviors. Return appointment intervals at a risk-based clinic vary according to patient's risk and includes a shorter appointment option for disease management; at a traditional clinic, return intervals are applied equally for everyone based on a six-month recall schedule. Both types of clinics (risk-based and traditional) recall patients for restorative treatment at the same interval, in this case, two weeks.

As an example of testing and iterating during model building, earlier in the development the model stopped reflecting the care that had been received. As case in point, a patient going for a filling did not shift from a state of having cavities to one with no lesions. It was discovered that a setting had inadvertently changed, causing all messages (which update and change an agent's state) to remain unsent.

Simulating the Effect of a Risk and Disease Management Approach to Caries on Population Health

Distribution of risk in the population

Figure 29 compares the populations of a risk-based clinic and a traditional one in terms of the distribution of risk; Figure 30 compares the distribution of lesion states in the population that results across 40 years.

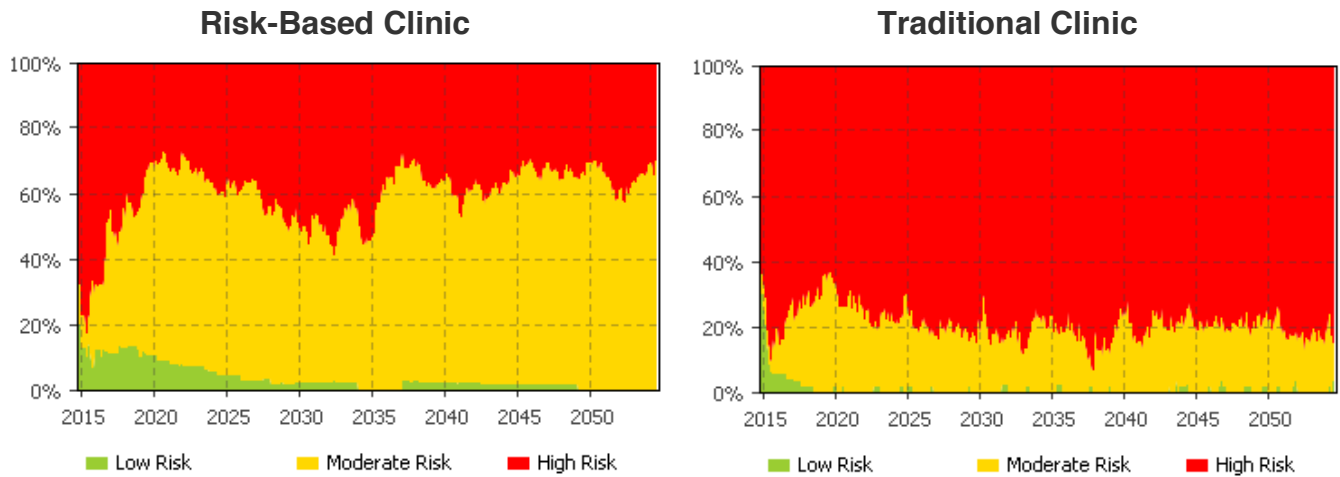

Figure 29. Distribution of risk states across a population of children (0–12). These results are from iteration 2, but all look quite similar.

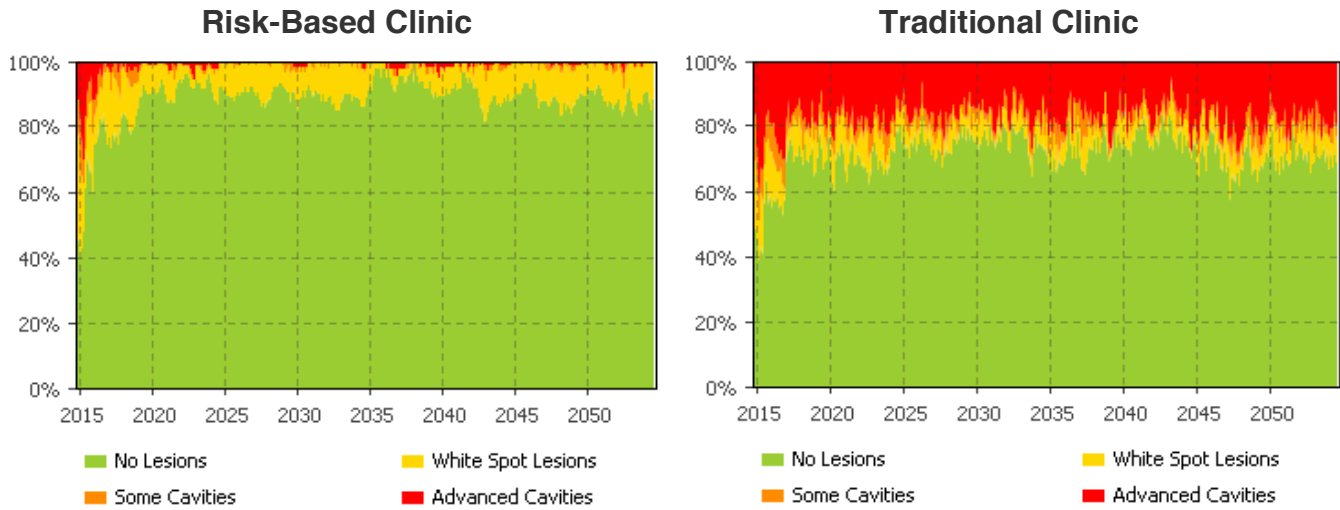

Figure 30. Distribution of lesion states across a population of children (0–12 years) attending a risk-based or traditional clinic

It is immediately apparent that the patient population attending a risk-based clinic appear to have lower levels of risk compared to a traditional clinic, where a majority of the population remains at high risk. It was surprising that so few individuals manage to be low risk and that so many are at moderate risk. This points to the need for further inquiry of the rules determining how someone changes risk states; perhaps there is a mechanism in place that causes agents to get stuck in a moderate risk state. On the other hand, perhaps it is a true reflection of risk in a population. With no objective data on population oral health risk, it is difficult to assess the validity of the distribution. However, in conjunction with the distribution of lesions, it provides a more complete picture.

The distribution of lesion states across the population shows that regardless of the dentist's approach, most of the population does not develop lesions or cavities. However, I had expected that the proportions would change over time at a risk-based clinic, with fewer agents being high risk over time, and requiring fewer visits to control the disease. Though there is a reduction in high-risk agents in the first five years, and some noise over time, the proportion of high risk versus moderate or low risk is relatively stable throughout the experiment. Additional analysis may be needed to confirm that this is indeed the case. A significant proportion of agents remain in the moderate risk category, more so in the risk-based clinic than in the traditional where agents are predominantly high risk is somewhat surprising, and deserves further investigation. This is likely a result of the action rules embedded in the model, which is making it less likely for agents to transition from moderate to low risk. Indeed this could be because the definition of moderate risk included agents who had extreme behaviors, like very low brushing and very high sugar, or no fluoride and very high sugar, and given that there are only three states from which to choose, perhaps these combinations might be fairly common.

I would also have expected the proportion of high-risk individuals to go down across generations at a risk-based clinic given that the mother's lesions are being treated as soon as she goes for a visit (and she always goes for her visit), but that is not observed. This suggests an examination of the way that individuals can inherit an infection is warranted. After correcting a code that had children getting infected even if the mother was not, the proportion of children at high risk decreased slightly over time (about 20% points over 35 years) and more were low risk, but it did little to change the shape of the distribution.

The determination of risk, however, does not account for an agent's bacteria level, because this is something that dentists generally do not assess, even if they do assess risk. The fact that about 40–50% of the agent population are still high risk in a risk-based clinic points to the need for further calibration on the model to ensure it is truly a resulting dynamic of the interaction and not a problem with the underlying rules or parameters.

Distribution of lesions in the population

The results for the distribution of lesions, however, is more in line with my hypothesis that the risk-based approach will keep more patients from advancing to later stages of disease, thereby reducing the need for future treatment. However, we also do not observe a significant trend over time. It appears to settle into a consistent pattern after the warm-up period. Figure 30 shows that few agents advance to having cavitated lesion, and instead those that have lesions (about 15–20% of the population) mostly have initial white spot lesions and a small percentage advance to some or advanced cavities. In contrast, of the agents attending a traditional clinic, up to 30–40% appear to have lesions and most of those are advanced cavities with a smaller percentage at the white spot lesion stage. In addition to preventing and reversing white spot lesions at a risk-based clinic, agents are also likely to visit more frequently so the dentist will catch cavities at an earlier stage.

The other aspect I expected to see was that by managing risk and disease, a risk-based clinic would prevent patients from advancing to later stages, thereby reducing the need for future restorative treatment. Figure 31 below shows the annual visits for the same simulation referenced in Figure 30. Risk-based clinics consistently had higher total number of visits as would be expected given a more intense scheduling for high-risk patients. Though the traditional clinic hovers around 150 patients per year and the risk-based between 150 and 200, the traditional clinic has about 40–50 more restorative visits per year than the risk-based clinic. Instead, the risk-based clinic has more disease management and six-month check visits, and restorative visits are consistently low. This does suggest that a risk and disease management approach, under perfect patient compliance, and certain assumptions about treatment effectiveness, could keep the disease in check and avoid the need for restorative care.

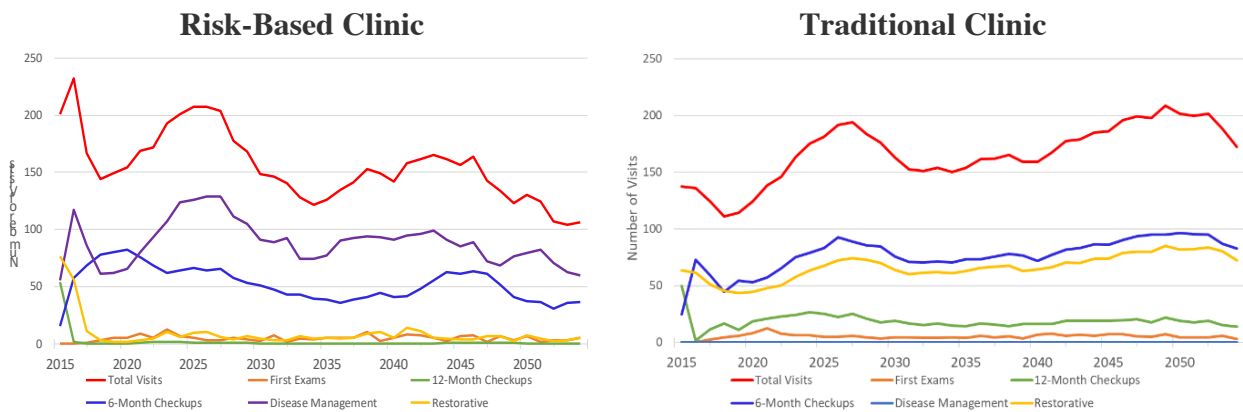

Figure 31. Annual visits at a risk-based and traditional clinic; total and by type (0–12-year-olds). These results are from iteration 2, but all look quite similar.

Simulating the Effect of a Risk and Disease Management Approach to Caries on Dentists' Productivity

Clinic visits & patients

My second research question relates to the effect of the risk-based approach to care on provider productivity in terms of number of visits and number of patients over time. As expected, a risk-based clinic had more visits per year, and slightly fewer patients than traditional clinics (Figure 32). Risk-based care incorporates a shorter interval between visits, resulting in a greater number of visits per patient over the year. After the initial settling of the model, there does not seem to be a trend in the data (other than sideways) — each clinic settles at a level and maintains that overall level over the years. Also, as expected and depicted in Figure 33, the average number of visits per patient is higher at a risk-based clinic than at a traditional one.

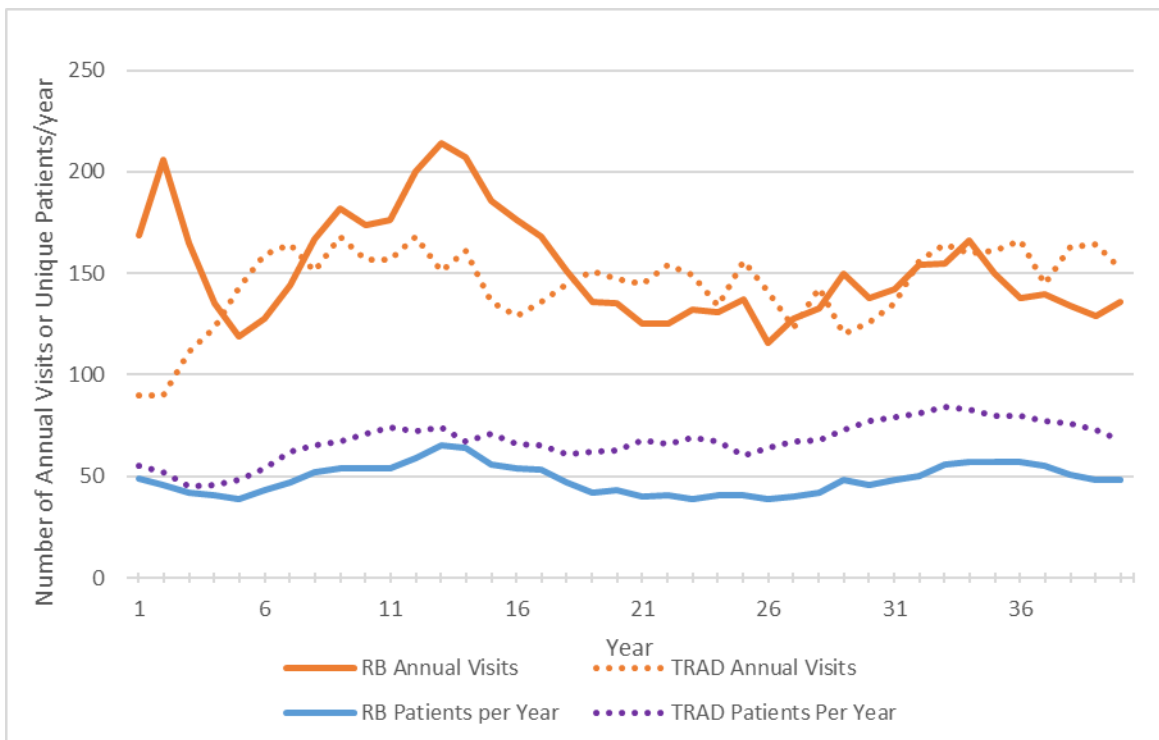

Figure 32. Total visits per year and unique patients per year for a risk-based clinic vs traditional

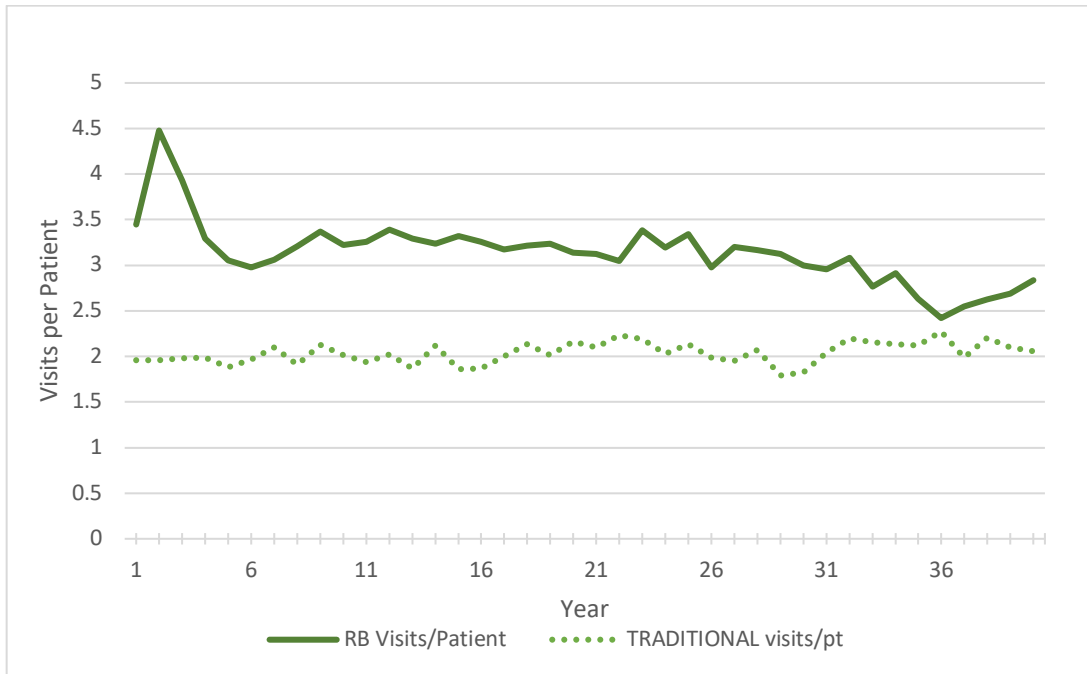

Figure 33. Average number of visits per patient per year — Risk-Based vs Traditional

Several output runs for visits, as well as for risk, show a bimodal pattern. This dynamic deserves further investigation and testing to see if it has something to do with an emergent pattern or whether it reflects rules and assumptions of the model.

Below is an example of a basic calculation of how the different distribution of visit times might translate with regards to the dentist’s productivity and capacity. In this example, we pulled data on the number of visits of each type for each clinic from year 10 of a baseline simulation run. We allocated typical times to each type of visit: 60 minutes for a first exam, 45 minutes for a 12-month and six-month visit, 10 minutes for a disease management visit, and 90 minutes for a restorative visit of a child. The only exception across the two types of clinics is that a 12-month visit at a risk-based clinic takes 60 minutes, compared to 45 minutes at a traditional one to allow time for the caries risk assessment and risk-based counseling. Under these assumptions, even though the risk-based clinic has 95 more visits than a traditional clinic, these visits account for 300 fewer minutes of the dental clinic staff time than those at the traditional clinic. If we were to

allocate only 60 minutes for restorative visits, the risk-based clinic still adds up to 130 fewer total minutes than the traditional (6,750 vs 6,620).

Table 14. Sample calculation of implications of differences in visit counts (at year 10)

Visit Type	Traditional Clinic			Risk-Based Clinic		
	Length of Visit	Visits	Total Minutes	Length of Visit	Visits	Total Minutes
First Exams	60	5	300	60	4	240
12-Month Checkups	45	40	1,800	60	5	300
6-Month Checkups	45	58	2,610	45	100	4,500
Disease Mgmt.	10	0		10	116	1,740
Restorative	90	34	3,060	90	7	630
Total		137	7,770		232	7,410

Sensitivity of Risk and Disease Management to Patient Factors

One of the advantages of building explicit models that can simulate a system or process is the ability to probe its sensitivity to varying parameters. This allows one to identify salient uncertainties and important thresholds, and reveal tradeoffs and sensitivities to particular variables or parameters. To translate knowledge into real-world practices, it is important to first understand the nature and behavior of the system within which changes would be implemented. This can help to anticipate unintended consequences or reactions and pushback from the system that can undermine implementation of effective improvement strategies. Being able to explain how a system might respond to programmatic or policy changes can help us develop more effective policies and processes, and increase their adoption.

As a proof of concept approach, the sensitivity analyses were limited to three aspects that could be of concern to a dentist considering this approach: the age at which children first visit the dentist, their compliance with return visits, and the effect of the risk of the community within

which they practice. Also, given the scope of this dissertation, the range of parameters to be tested in each of these sensitivity analyses was limited. Even so, these tests give insight into emerging patterns and the functioning of the system, and provide direction for further exploration. Table 15 describes the scenarios tested and parameters that were modified.

Table 15. Description of Scenarios Examined

Ref #	Scenario	Sensitivity parameters		
		Age 1st Visit	Risk Profile (%H – %M – %L)	Compliance
<i>Risk-Based vs Traditional</i>				
1	Baseline	1–6 yrs	10-25-65	100%
<i>Age of 1st Visit</i>				
2a	1st visit, 1–2 year	1–2 yrs	10-25-65	100%
2b	1st visit, 2–3 years	2–3 yrs	10-25-65	100%
2c	1st visit, 3–4 years	3–4 yrs	10-25-65	100%
2d	1st visit, 4–5 years	4–5 yrs	10-25-65	100%
2e	1st visit, 5–6 years	5–6 yrs	10-25-65	100%
<i>Initial Population Risk</i>				
3a	Very Low	1–6 yrs	5-25-70	100%
3b	Low Risk	1–6 yrs	10-25-65	100%
3c	Moderate	1–6 yrs	15-25-60	100%
3d	High	1–6 yrs	50-25-25	100%
3e	Very High	1–6 yrs	70-25-5	100%
<i>Patient compliance</i>				
4a	Low	1–6 yrs	10-25-65	25%
4b	Moderate	1–6 yrs	10-25-65	50%
4c	High	1–6 yrs	10-25-65	75%

Scenario 1 – Age of first visit

Guidelines recommend that the first dental visit be within six months of the first tooth erupting, or not later than one year of age. Evidence suggests that when care is initiated early, it decreases the need for later restorative care. There is also an added benefit of having a first visit for a young child that is fun and not painful for the patient, parent and dentist. This minor point may not be so minor when it comes to general dentists’ willingness to attend to young children. Presumably, if children at risk for caries disease delay care, they would be more likely to present at the dental visit with signs of disease, or needing immediate treatment. Also, my expectation

was that when care starts at an older age, especially for high-risk children, more days will be spent with lesions. With the disease well established, it reduces the dentists' ability to prevent and manage the disease early.

Therefore, this analysis was proposed to test how influential the age of initiating dental care can be on future experience of caries disease, i.e.: how much time an individual spends with cavities (either some or advanced). This sensitivity test adjusts the age at which the initial appointments are given to infants using the range between the maximum and minimum of a uniform probability distribution. The 2D histogram (Figure 34), was generated by the simulation that uniformly gave appointments between 12 months and 6 years of age. It shows greater density of people spending more years with cavities, especially when care is initiated between 4 and 5.5 years of age (1,200–2,000 days).

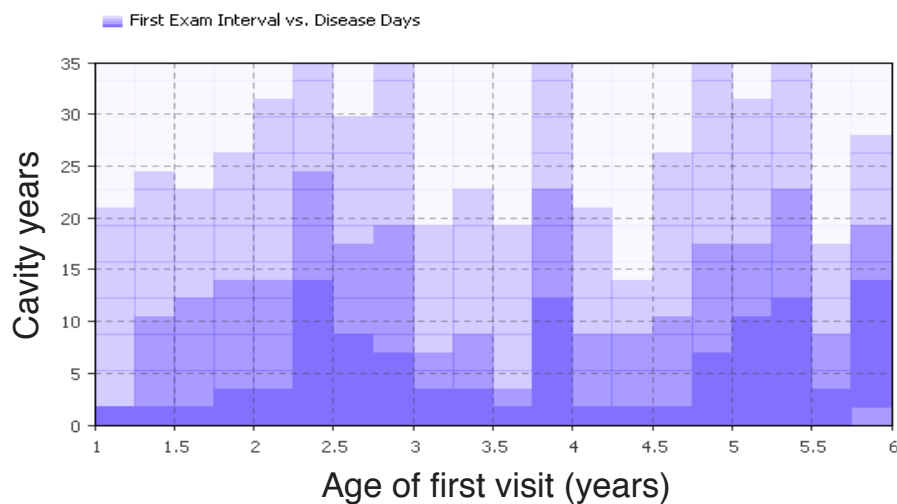

Figure 34. A 2D histogram of age of first dental visit by cavity years.

A 2D histogram is like a classic histogram, except it uses bins with length and width, so the color density indicates the relative frequency of data points in that bin.

Sometimes it is difficult to appreciate the dimensionality of a 2D histogram, so a 3D histogram was developed to demonstrate how the same data from the 2D histogram looks using a 3D histogram (Figure 35 and Figure 36). Furthermore, I was interested in how this dynamic would play out across the two types of clinics. Figure 36 provides an example of a 3D histogram using the average of 5 simulation runs for “cavity years” by age of initiating dental care, for the whole population, and then compares those who attend a traditional with those attending a risk-based clinic. The caries morbidity of agents attending a traditional clinic show what is likely the experience of many people who live with cavities for long time. At a risk-based clinic, we do see a slight an increase in morbidity when care is started later, but almost all agents do not experience caries. This figure, reveals a possible link between not just the age of first visit and future morbidity, but also points to possibly interactions between delayed care seeking and clinic schedules and practice, with life course implications, especially for high risk patients.

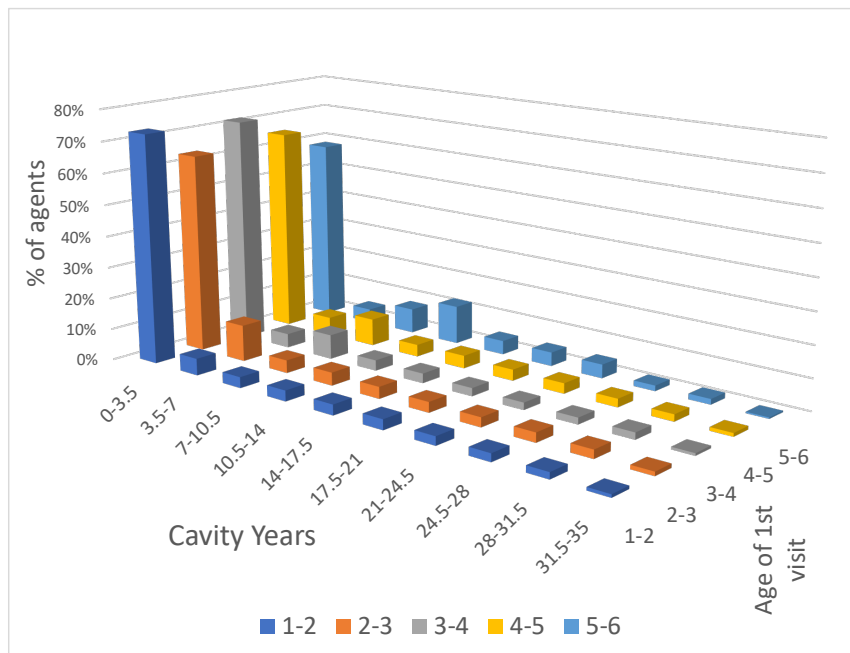
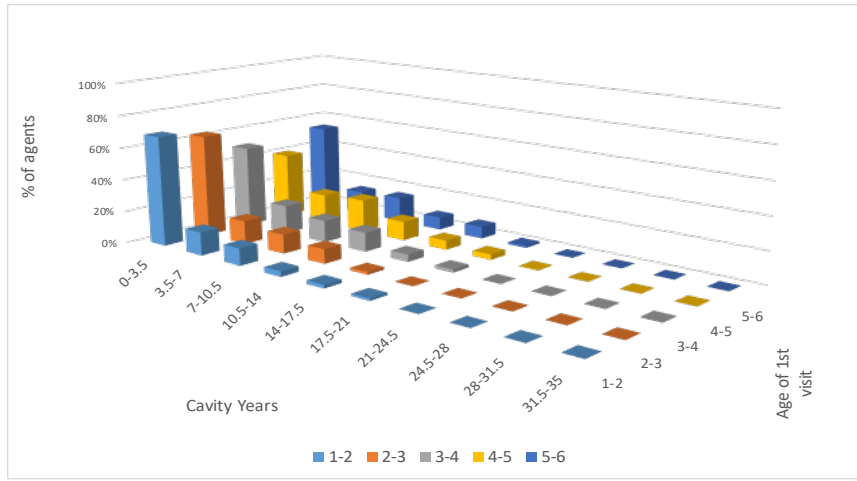
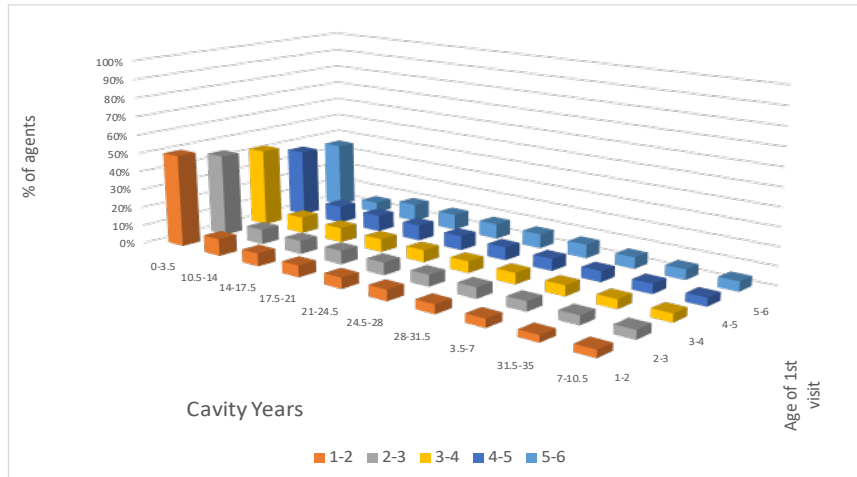

Figure 35. A 3D Histogram of percent population by age of first dental visit and time with cavities (cavity years)

AVERAGE OF TRADITIONAL AND RISK-BASED



TRADITIONAL CLINIC



RISK-BASED CLINIC

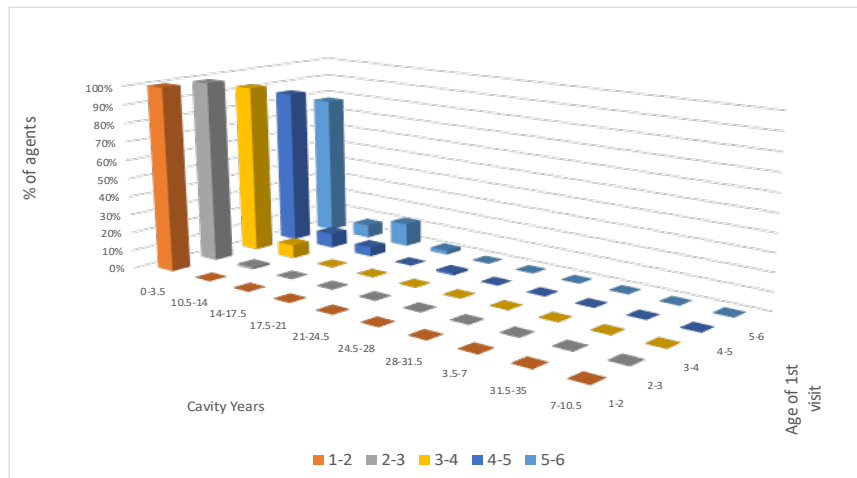

Figure 36. Age of first dental visit by cavity years, by clinic type; average of 5 runs

Figure 37 shows the resulting distribution in risk and lesion states for scenario 2, as first visits are changed to occur at an older age.

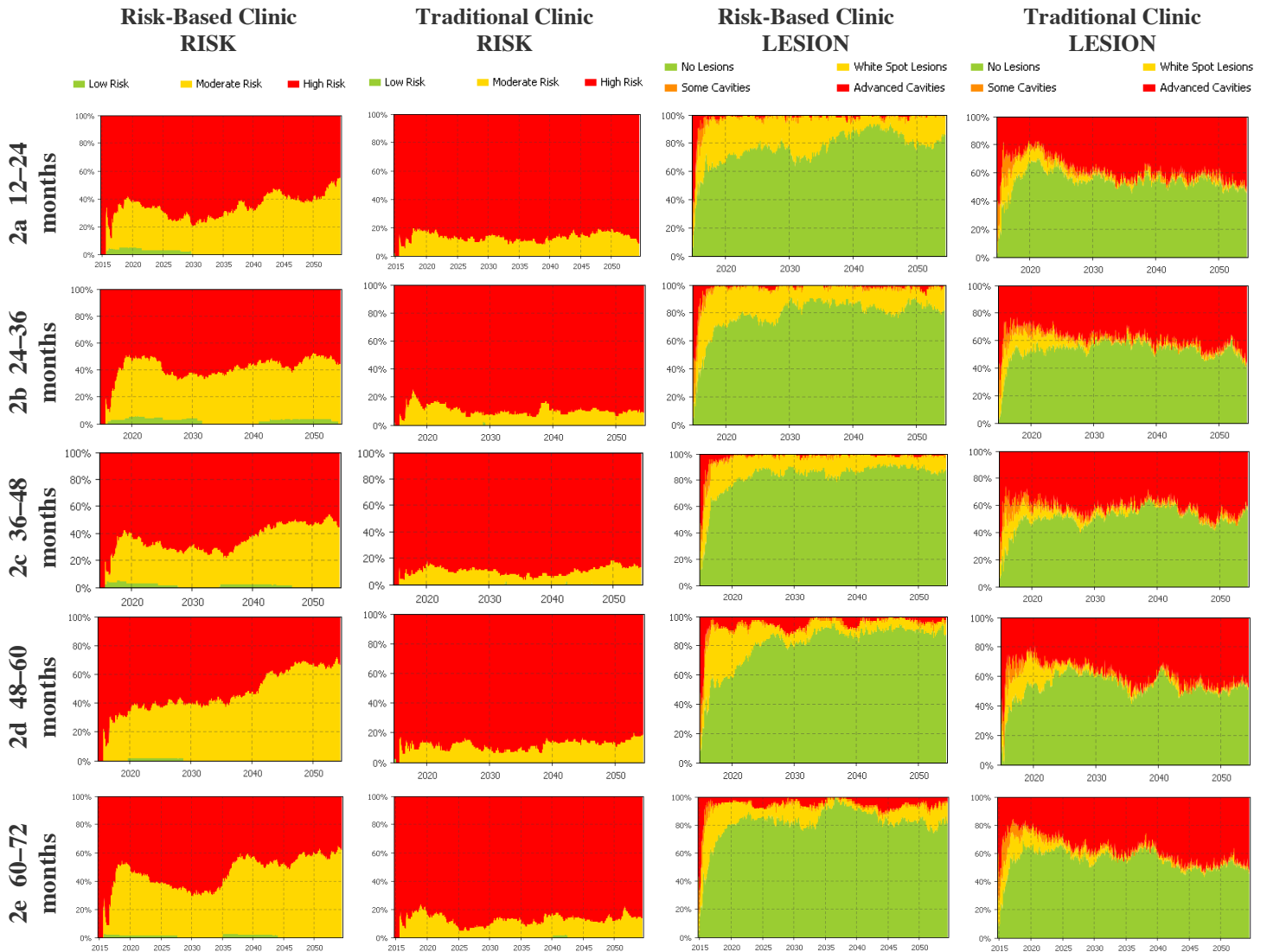

Figure 37. Results of sensitivity analysis 1; age of first dental visit. Effect on risk and lesion distributions by type of clinic. (Results from run #2)

The changes are very slight, less than expected. However, even small percentages in changes could have significant impacts on cost of care across a population. The most notable difference of starting care at an older age is that more agents develop lesions. Especially at a risk-based clinic, there is a slow increase from what is barely noticeable to 5–10% with advanced cavities

(the red strip at the top becomes more apparent). There is also a slight increase in volume of high-risk agents and those with cavities at a traditional clinic. A surprising result is that at the traditional clinic, more agents appear low risk than they did when everyone attended by 12–24 months.

Scenario 2 – Risk profile of the population

There is not much data on risk distribution in populations because this is not something that dentists regularly assess and document in a way that can be aggregated and studied across patient panels, let alone communities. Neither is this the kind of data collected in population surveys or dental plans. In their system dynamics model, Edelstein et al. used as a proxy for risk the responses to a National Survey of Children question about how a parent rated the oral health of their child (Edelstein et al., 2015). Using this method a risk distribution for New York resulted 62.3% rated as low risk (excellent or very good), 25.8% moderate risk (good), and 11.3% high risk (fair or poor) (Edelstein et al., 2015). I decided to use a similar distribution for my baseline, and to vary the high and low percentages while keeping the moderate population the same at 25% across all scenarios. This allows testing a few extreme situations without needing to have more combinations of the three categories. There is population data that suggests higher and lower disease levels, especially when comparing with Scandinavian countries, but data was not found with regards to the risk of a panel of patients, or a community served by a dentist. Though it seems high, I expect that there exist communities where 70% of patients would be considered high risk.

Figure 38 illustrates the differences in total visits and types of visits that result under different risk distributions of the population (denoted as H, M, L for high, moderate and low). A dentist practicing in a high-risk community is likely to have more patients with advanced disease, requiring restorations.

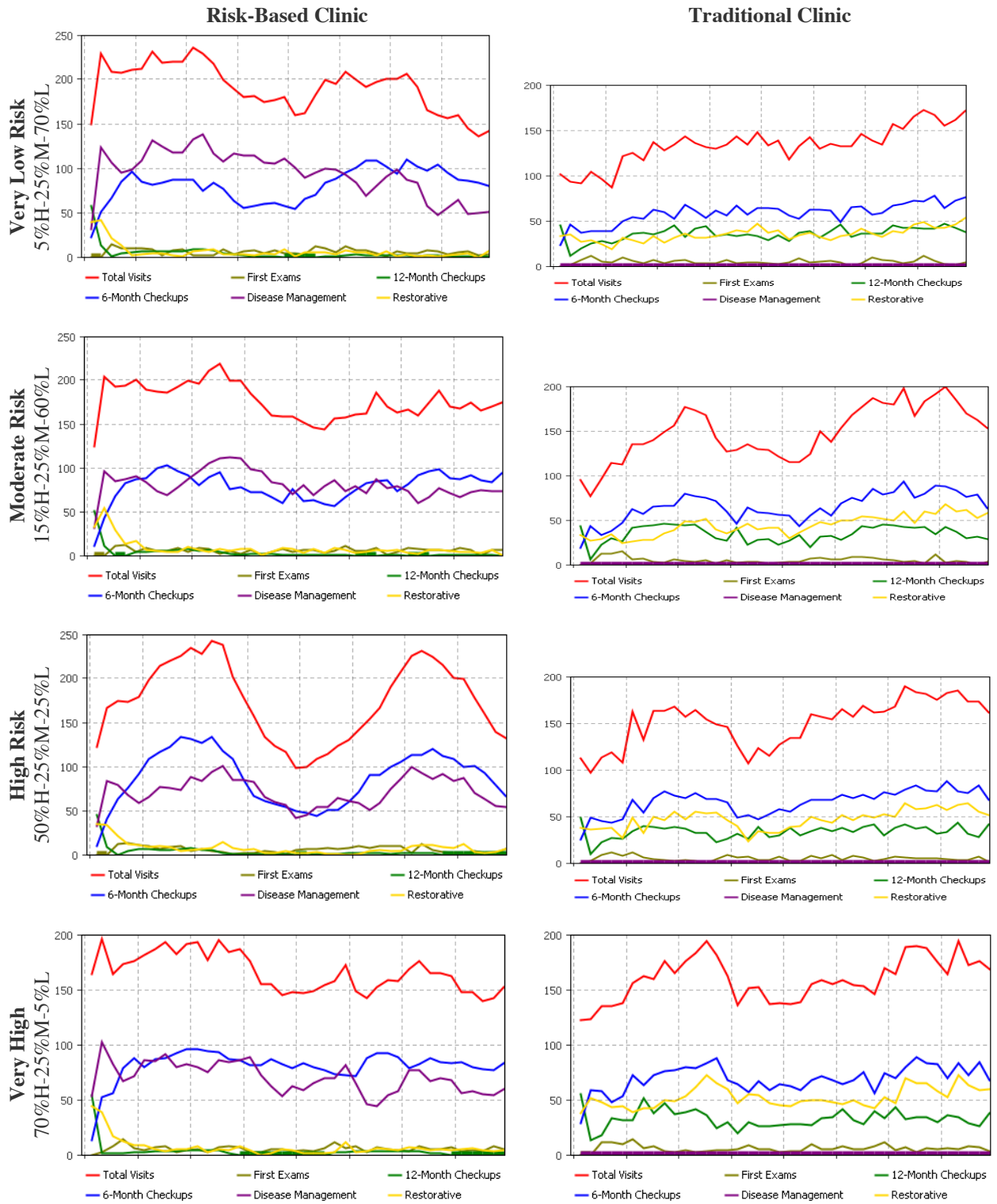

Figure 38. Results sensitivity analysis 2; Population risk profile on the volume and type of visits by type of clinic)

Scenario 3 – Missed appointments

Implementing the level of missed appointments posed some operational challenges and led to several decisions. If an agent missed their appointment, how were they to be rescheduled? This question initially helped inform the design of the next appointment in the DES: The exit appointment was linked to the current appointment for which they came into the clinic. For example, a high-risk patient that came in for a three-month disease management visit would be scheduled at the exit for what is normally a six-month periodic exam, but within three months, given that they are high risk. In the end, this was operationalized in the care-seeking state chart as follows: each individual has a probability of missing their appointment; if they miss it, they are rescheduled with another appointment like the one they missed, with a similar interval starting from the current day. In addition, a graph on the simulation interface displays the number of missed appointments at any given clinic.

We compare the effect of having a 25% probability of missing an appointment (Figure 39) to a 75% probability on the risk and lesion states in the patient population (Figure 40). Then we compare the effect on the number and types of visits (Figure 41, Figure 42, and Figure 43).

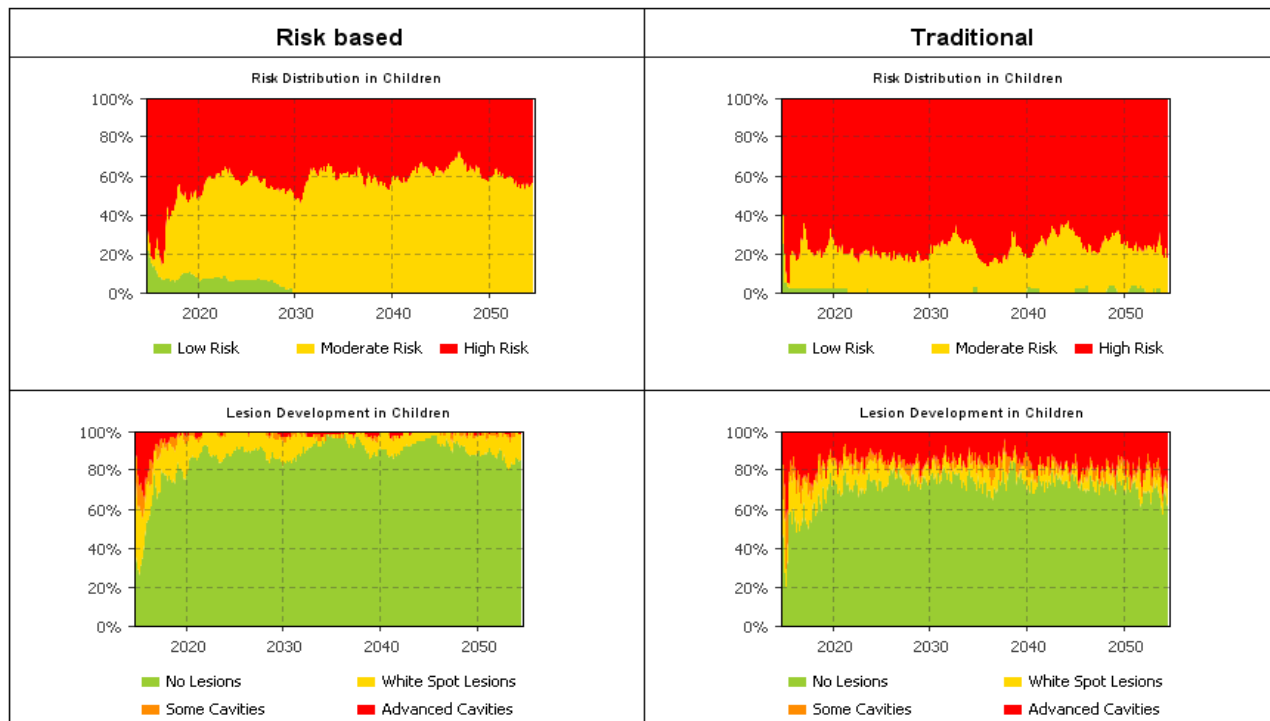

Figure 39. Agent probability of missed appointments (25%) on risk and lesion status

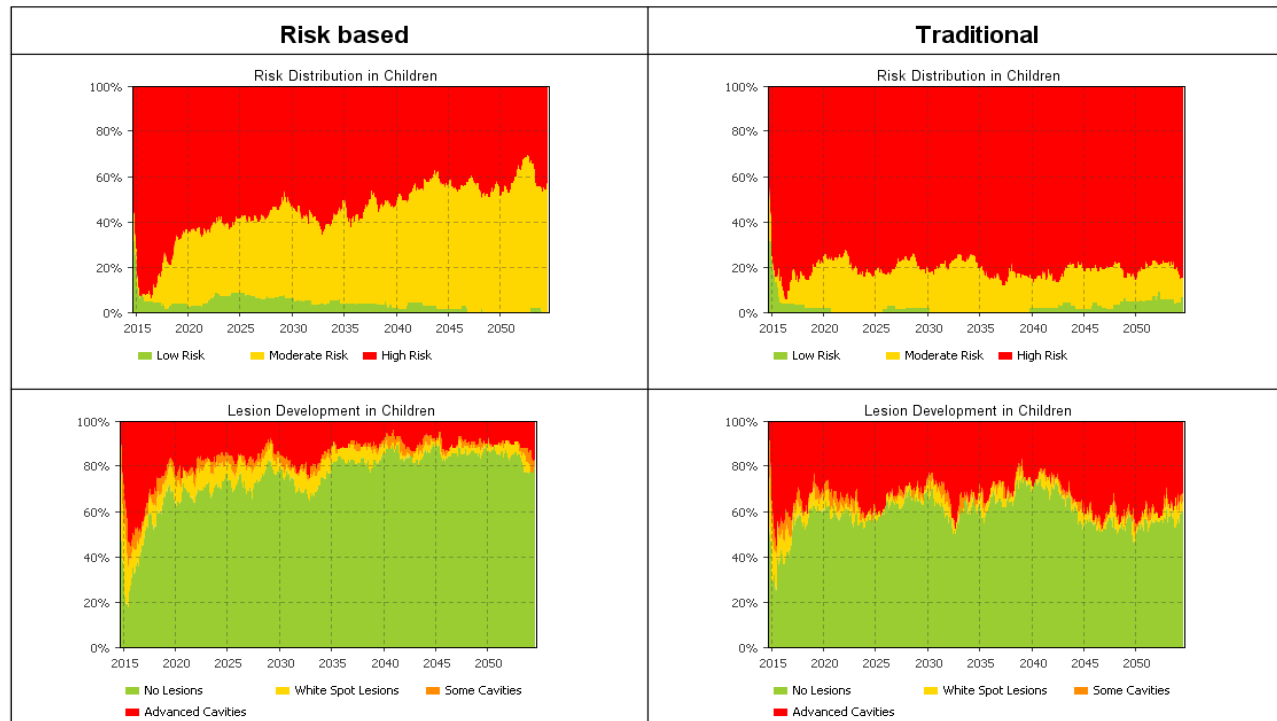

Figure 40. Agent probability of missed appointments (75%) on risk and lesion status

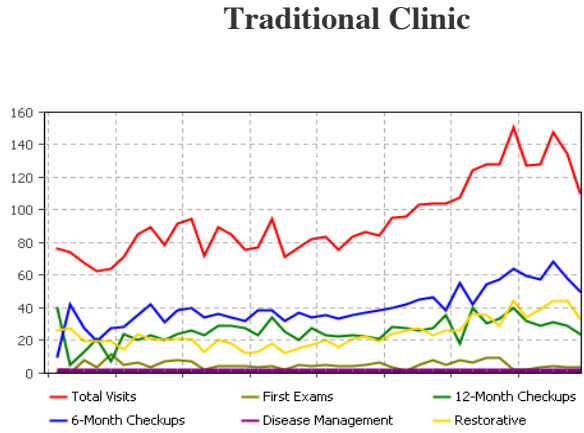
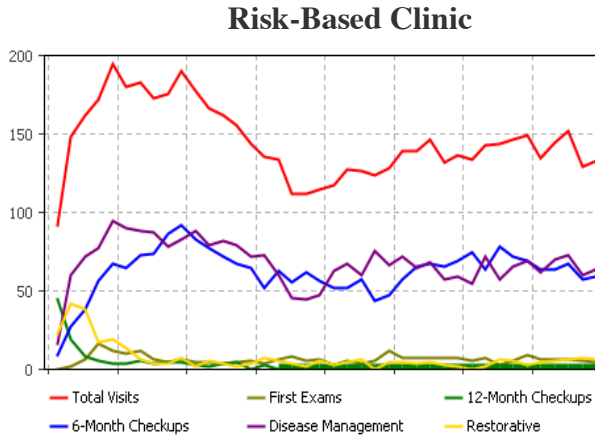

Figure 41. Agent probability of missed appointments (25%) on total Visits and types of visits (years 2015-2055)

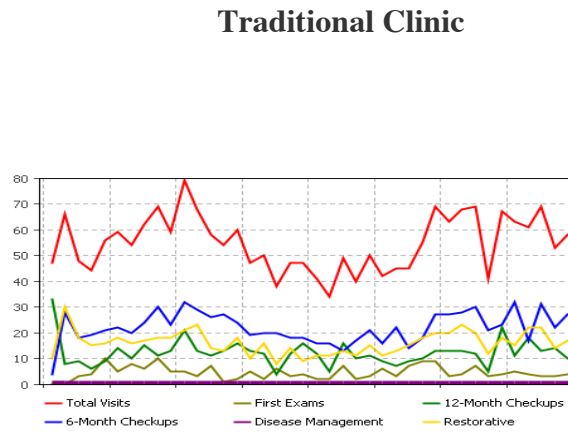
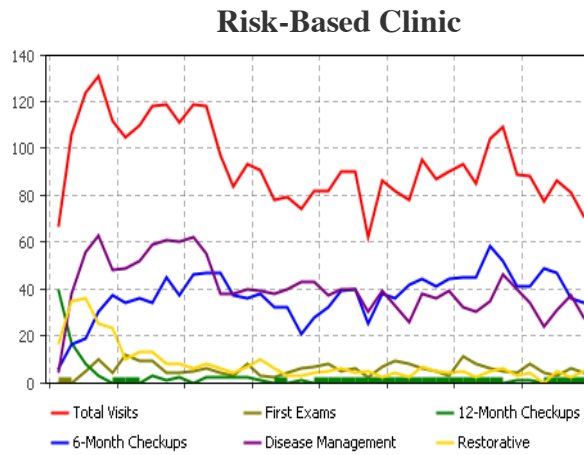

Figure 42. Agent probability of missed appointments (50%) on total visits and types of visits (years 2015-2055)

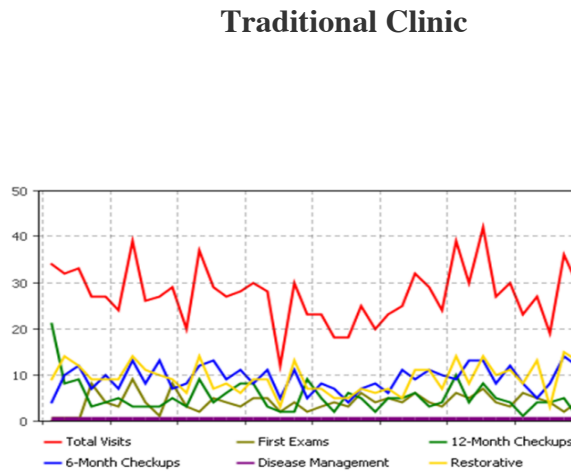
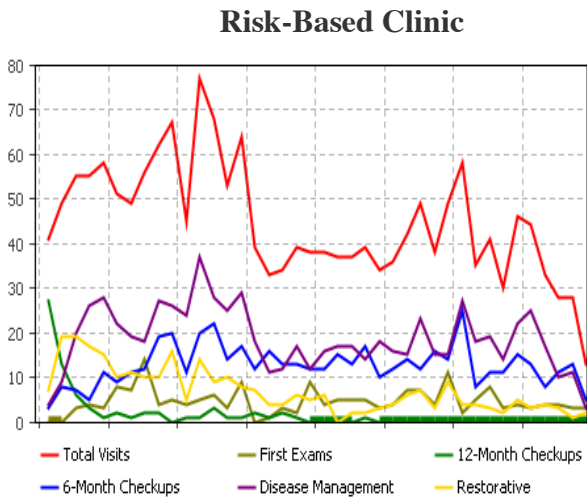

Figure 43. Agent probability of missed appointments (75%) on total visits and types of visits (years 2015-2055)

As would be expected, missed appointments affects both the proportion of the population at high risk and the percent of the population with cavities. The effect on the proportion at high risk appears to be greater at a risk-based clinic: There are many more agents at high risk when there is a 75% probability of missing an appointment than if it is only 25%. At a traditional clinic, on the other hand, missing appointments has little effect on the proportion of high risk in the population. However, the probability of missing appointments has a noticeable effect on the proportion of the population presenting with cavities at both clinics. At 25% level, the proportion with cavities is not noticeably different than at 0% at either clinic. However, increasing to 50% and 75% shows a progressively greater proportion of agents with cavities, and the traditional clinic having at the end almost four times the proportion of children with cavities than a risk-based clinic. The risk-based clinic does also show a trend of fewer agents with lesions over time — both white spots and cavitated, which the traditional clinic does not.

The effect on the visits at the clinic shows an inverse relationship between the probability of missing and the overall number of visits, i.e. as the chance of missing appointments increases, the overall volume of annual visits decreases (note the decreasing scale of the graphs in Figure 39, Figure 40, and Figure 43).

Two other results stand out from this analysis. First, given the effect on the disease in the population, higher rates of missed appointments result in higher number of restorative visits at a risk-based clinic, but has little impact on the proportion at a traditional clinic, likely only decreasing proportionally to the overall decline in visits. Second, and this perhaps a result of small numbers, is that more missed appointments results in greater variability in the volume of visits across years.

In summary, the results of this hybrid simulation model (ABM-DES) suggests that a risk and disease management approach to caries can positively affect the oral health of a population by intervening earlier in the disease and promoting healthy behaviors to slow the progression of risk and disease. Though dental clinics using this approach may have higher volume of total visits for fewer patients, the resulting improvement in oral health may provide a worthy tradeoff. Furthermore, in the graphs of visits, visits all appear to have the same weight, while in reality a two-hour restorative visit for a young child takes many more resources than a 10–15 minute disease management visit. One of the tradeoffs we observe in the patterns of visits is that risk-based clinics have more disease management visits, and traditional clinics have more restorative visits. Table 14 (on page 225) provides a basic sample of what these differences in types of visits could mean for the operations of the dental practice. This can help visualize how production output and effectiveness of care can work together to create value in dental care. This suggests a viable option for how dentists might “work smarter” rather than “work harder” to achieve improved oral health in a population.

Results also suggest that patient factors could affect the effectiveness of the risk-based approach to care, and should be considered in the design of policies or implementation programs. Missed appointments, in particular at rates higher than 25–50%, can undermine a dentist’s ability to prevent disease, resulting in more cavities and the need for more restorative care. The age of first dental visit can expose a child to longer periods of decay. The risk profile of the population merits further exploration as the relationships with the varying distributions of risk are not immediately appreciable in the graphs.

Chapter 6. Synthesis and Implications

Causal Loop Diagram

Feedbacks help us see patterns of change and structures behind events and details. This feedback perspective on systems helps us understand how we share responsibility for problems generated by a system and counteract the instinct to find scapegoats, blaming others or external forces.

Senge (2006) refers to it as “a particularly alluring pastime [of] individualistic cultures such as ours.” Berwick (1989) refers to this phenomenon as the “theory of bad apples,” trying to find the one responsible for the breakdown of the process.

Lessons Learned from the Modeling Process

Although it is more common to find publications mentioning system science and using complex systems methods today than even five years ago, there is not a wide saturation or experience in the field to provide examples with enough detail for one to emulate the process for learning how to build models, and interpret and apply the findings. One often has to draw from examples outside public health and health care. However, it was immensely helpful to find a hands-on bootcamp/workshop in simulation modeling in health and health care. There are people who understood modeling but do not understand population health or health care; and there are people who understand health services and population health but do not grasp the power of simulation modeling — and this not as a predictive tool but as a mode of inquiry into the systems that surround us and what we study. This is an important space for public health practitioners to learn to navigate, to contribute the body of examples and applications to solve public health dilemmas.

Furthermore, the ability to bridge simulation models with traditional statistical and epidemiologic approaches is another important skill to pursue. They are not competing, but rather complementary approaches.

Undertaking the development of a model to understand a system and illuminate some core dynamics provided experience in several important practical aspects of the modeling process:

1. *Choosing a modeling method* — ABM is optimal for models that require interaction between heterogeneous agents or between agents and the environment; where there is individual-level (and particularly longitudinal) data or interest in dynamics within and across levels of aggregation. SD is particularly useful when there are issues concerning accumulation, and aggregate-level and feedback data is available. DES is particularly useful for representing processes with discrete steps that may need to consider resources constraints such as staff, physical space, and time, and where queue length and time are of interest.
2. *Choosing a software platform* — Hybrid models that combine two or more methods are not common, and few tools have the ability to seamlessly link the different methods as AnyLogic does. Realizing that an ABM-DES combination was what I needed, along with a source of support for learning it, helped make AnyLogic the choice of software. It is also notable that the flexibility of the package further supported seamlessly adding an SD model for representing bacterial dynamics during learning about the model
3. *Acquiring the technical skills* — Skills take time to develop. Having a community within which to learn these skills is optimal. However, working in partnership with a programmer or modeler who already has the necessary skills may be a more practical model for public health practitioners.
4. *Learning to work with a programmer and defining roles.* It is important to be able to articulate the specifications of a model to the person providing technical assistance. Any experience one can acquire in model-building will help provide insight into the type of information a programmer will need, and all the levels of planning for model development.
5. *Modeling is best done in collaboration.* Whether it be with a technical partner or other stakeholders, having insights from different perspectives provides for richer models. Having to explain one's reasoning and consider alternate ones is helpful in building theories. Trying them out is part of iteratively learning and an important aspect of modeling. When it is discovered that the model does not match some empirical data, it is not a failure of the model, but a success of the learning process. Modeling is best used as a learning journey, with the model as a learning tool (a learning prosthesis) to help us reason more deeply, reliably and quickly about the world, and what evidence implies about our hypotheses for "what's going on out there."

6. *Defining model boundaries.* What level of information is necessary to answer your questions, and what questions are important to answer, are essential parts of discover, and change during the course of research and investigation. Iterating during the modeling process often helps answer these.
7. *Acquiring or adapting data to inform the model.* With an emphasis on traditional statistical methods, collecting or reporting data about the processes underlying the constructs studied does not always seem relevant, especially since we have lacked ways of productively using the information. However, a lack of data should not limit what we study or try to understand. It is valuable to applying logic and reasoning using available data and making explicit our assumptions about the world where data is not, in order to build models that can in turn inform what types of data we should be collecting and reporting. Modeling and agent-based models in particular, use a combination of inductive and deductive reasoning.

The Hybrid Simulation Model (ABM(SD) – DES)

The problem chosen for this pilot simulation is one that exists in a space between the disciplines of dentistry and public health. Steven Spears speaks of two reasons why health care often does not “get it right”: it is organized by discipline, without process ownership, and training is organized almost exclusively around the discipline itself without regard to systems training (Spears, 2008). This is also true of dentistry where dentist receive limited training in systems thinking or population health. In turn, public health professionals have limited exposure to population oral health problems, or the intricacies of the dental care delivery system, workforce and payment mechanisms.

The findings from the simulation model provided a useful demonstration of the capacity of these types of simulations in terms of the type of data they can generate, and the dynamics and non-linear behaviors they can shed light on. Though this was a fairly stylized model and inputs can benefit from further calibration, it does give a sense of how certain behaviors and practices at the individual level can ripple through the system and result in undesirable population health patterns. Our bounded rationality often interferes with us seeing how our small actions can result

in important reactions or patterns at the system level. An example of this is the effect that minor changes to scheduling intervals can potentially have on disease and visit patterns. Or individuals missing appointments but not realizing the impact that this has on the dentists operations, and their own health.

The above results are based on several significant assumptions about the rate of disease progression and particularly important, patients' compliance with care-seeking. In other words, they capture how this approach would play out under the best of circumstances, which is not a luxury that a dentist can usually count on. However, in planning an intervention, or thinking through how guidelines are to be implemented, it is useful to start with an understanding of how an approach is intended to work in order to assess the impact of various threats to the fidelity of its implementation. The sensitivity analysis provided a way to probe the system and do exactly this.

Though this model is not designed to predict, it does build trust in the model's structure when the results align with what others have found. The first sensitivity test I conducted showed that those that started care later suffered greater caries-related morbidity throughout their life. This aligns with what Savage et al. (Savage, 2004) found, that dental-related expenditures increased with an increased age at dental first visit, presumably because of higher morbidity. This gives a sense that the model might be capturing some of the endogenously determined pathways that result in people with past caries experience being at higher risk for future decay. The difference between the two types of clinics also provided supportive evidence that the model may be capturing some important differences. When we looked at the population distribution of risk or lesions, not much difference was detected, but the 2D and 3D histograms using individual level longitudinal data showed appreciable differences.

The population risk sensitivity analysis had its technical challenges, but it also provided a way to think into the relationship between risk and lesion status and showed how systems can often reach equilibrium, a characteristic of the model. The results suggest that lesion status might be a more sensitivity measure to test against in future simulations.

As expected, patient compliance with appointments had an impact on visit volume and resulted in more patients with lesions, even more so in the traditional clinic. As a demonstration I used limited parameter values for the test. The results suggest that there might be some kind of tipping point at higher levels of missed appointments, but given the limited range it cannot be detected. This indicates a link between structure and behavior is playing out, and understanding the vulnerabilities of our structures is important. In other words, there is something about a traditional approach that resulted in worse outcomes when people miss appointments. Given that high-risk patients, and Medicaid patients in particular, are reported to have higher rates of missed appointments (Iben, Kanellis, & Warren, 2000), this would be an important consideration for program managers and dentists to understand.

Implications of Findings

Given that this was a demonstration of the methodology applied to a dental care and population health problem, the results need to be handled carefully. While we cannot use the results to derive specific implications for dental care practices or policies related to population health or dental care, we can draw some implications for our approach to health services research and even public health practices more generally. The methods piloted in this dissertation demonstrated utility in handling different types of data and processes within and across levels of aggregation. This has implications for how we understand and learn about systems of care and population

health. The type of models used here could inform and facilitate conversations between policymakers and dentists. Furthermore, simulation models can be used as a tool to support quality improvement efforts that are more complex and require change at various levels of an organization. Testing ideas out *in silico* could save time and money.

Though not a direct finding of the model, the process of obtaining data for the model unveiled the limited amount of information available on patient panel or population management in the dental space. One would be hard-pressed to find literature, academic or otherwise, on population or patient panel management in dentistry. However, ample information is offered on “practice” management and how to manage the business of a dental practice. This is perhaps a reflection of the predominance of solo practitioners in dentistry, with limited scope for undertaking outreach or panel management.

A simulation model as well as a causal loop diagram can be used as a communication tool to work with stakeholders to develop better policies and more successful programs. It can help clinicians appreciate and visualize the effect of clinical protocols and practice management practices on a group of patients, or how their efforts contribute to the health of the populations they serve. Several studies have noted that a concrete and structured personality style predominates among dentists (Clayton, 2016; Needleman et al., 2011). Being able to simulate practices in a concrete way like this might provide a proxy for direct experiences, allowing the dentists to observe things that are generally unobservable in the real world, or for them to see their responsibility in the system at both an individual or corporate/professional level.

Health care utilization research has focused much attention on patient factors influencing use of services; and perhaps because providers have limited influence on structural, predisposing, or enabling factors, recommendations for addressing inequalities have often focused on long-

term social policies to intervene in upstream causal factors and determinants of health. While these changes are possible, the feasibility for meaningful changes in the short term may be limited (Hibbard et al., 2008). Furthermore, surveys of dentists indicate that services provided are more often related to characteristics of the provider than of the patient, except for the patient's insurance status (Gilbert et al., 2015; Pourat & Marcus, 2011). Rasanathan et al. (2011) holds that primary care services that do not consciously address social determinants actually “exacerbate health inequities”, this points to structural connected to behaviors relevant to my simulation model. When services designed for low risk individuals are offered to high risk individuals, the high-risk individuals end up worse off because they need *more* services. This is what Starfield (2011) refers to as vertical inequity — those with greater needs do not receive greater services.

It is for this reason that in this project we study the behavior of the dentists and their role in contributing to the system and pattern of behaviors it produces — both in the short and long term.

According to Sterman (2002), system thinking capability requires several things:

- the ability to understand complexity, and its characteristic dynamics (feedbacks, time delays, nonlinearities, etc.);
- the use of formal models and simulations;
- commitment to highest standards of scientific method along with
- the inquiry skills to expose our hidden assumptions and biases;
- that we listen to others with empathy and respect;
- that we remain curious and keep asking “why” questions; and
- that we have the humility to learn and the courage to lead, “even when all our maps are wrong.”

This is not a list one can just check off — it reveals a lifelong journey of development and growth to aspire to.

Chapter 7: Conclusions & Research Directions

In reading how Sterman defines requisite skills for capable systems thinking, it became clear that this project is just the beginning of establishing those skills — they need to be honed and exercised. Establishing a foundation for what Epstein refers to as “habits of mind” is essential to lead, collaborate, and bring to the field a methodology that promotes a scientific mode of inquiry and collaborative pursuit of solutions.

Many of my expectations about this project were fulfilled through its course, with some bonuses. I not only learned a whole new language associated with a broad field dedicated to thinking about system; I also tested and demonstrated the utility and feasibility of several tools in the system science toolbox. Both sets of primary tools revealed new and useful ways of thinking about and studying complex systems. Additionally, piloting a hybrid simulation model using not two but three of the most common methods provided practical and theoretical experience of applying systems science to a complex public health problem, as well as introducing the hybrid approach to the field of dentistry.

Part of the value of models is that you can create a reasonable model and design scenarios where currently no data exists, and “see what happens” and refine our understanding through experimentation. Researchers often avoid studying issues where data is lacking or difficult to produce; we no longer have to do that. In some sense, the paucity of individual level data is why we turn to models; if we had perfect data we might not need them. Osgood often quotes Francis Bacon who, many centuries ago, said “truth emerges quicker from error than from confusion” — i.e. fail early, fail often. Try something, make explicit your assumptions and biases, allow observations to be critiqued, refine, try again.

People unfamiliar with systems science and its methods might shy away from them, concluding that it is simply a case of GIGO (garbage in, garbage out). System scientists would

argue that the validity of models is in making them explicit. Everyone has models; in most cases they reside mostly or entirely inside one's head, never seeing the light of day. Systems science offers a method to draw those models out and make them explicit. The nature of how computers require information force us to make the relationships inside simulation models by adding action rules that govern a system very concrete. This helps draw out our assumptions. Once these are out of our heads, they can be scrutinized, critiqued, corrected, advanced, or revised, moving us to a new place of understanding. This level of transparency is not typical in health care, or more generally in academia. Epstein (2008) sustains that modeling democratizes knowledge in that it enforces habits of mind essential to freedom — freedom to doubt and ask why. Modeling, like quality improvement, can level the playing field where even the lowliest person can challenge a leader because they may have insight into the system from the front lines that the leaders do not.

System thinking tools and simulation models hold great potential to provide insight into the mechanisms that drive disparities and help identify and test solutions for population health and health care problems. They can also help us see our responsibility and contribution to system problems, they foster collaboration, communication and a learning process open for others to participate. For these reasons, systems thinking and systems science methods are an invaluable set of tools for public health practitioners and complement to traditional methods.

Need for Training

There is a need for more curricula both of the language of systems and its application, so that as with a language, with practice one starts to think in it. Like language, having the vocabulary of systems becomes an instrument of thought giving us a unique way of structuring the world around us, and making certain perspectives available to us and our thought process (Asoulin, 2016). The findings of this project, from building the system map to the simulation model, has made apparent

the need to develop system thinking capabilities throughout public health training. It is not something to be learned in one course. Developing systems thinking capability should not only be a focused series of courses for those planning to practice where these skills can be established and developed but should be woven into core courses throughout the course of study.

Limitations of the Research

The model presented in this dissertation generated some useful insights. However, these insights must be placed in context of the model limitations. George Box has famously said that “All models are wrong, but some are useful” (Box, 1979). The expectation of a model is that it provides a useful approximation to the real world, but because no model embodies the whole truth, the important question is whether the model is illuminating and useful. Epstein says that “all the best models are wrong”, but they can still capture qualitative behaviors of overarching interests, and thus be “fruitfully” wrong (Epstein, 2008). The hybrid simulation model (ABM-SD-DES) includes numerous simplifications and assumptions about human behavior, disease, dental care process, and time (described in the methodology chapter). The simulation model was purposefully stylized and not intended for precise prediction purposes, but to generate insight about overall dynamics and system behavior.

Limitations in the causal loop diagram

Although causal loop or structure diagrams can provide useful insight and understanding of relationships between identified system elements, the overall net effect of all these loops cannot be determined merely by inspecting the diagram. This requires a quantitative SD simulation. While a good mapping process can help us expand our mental model and see previously unrecognized feedbacks, qualitative models alone expose us to one of the important limitations

of our human cognition that drives us to simulate in the first place: Our inability to simulate mentally the dynamics of complex nonlinear systems (Sterman, 2002).

Communicating these maps can pose additional challenges. Some people are not visual thinkers and may have difficulty following or accepting the insights, and it can be difficult communicating to someone who has not had exposure to the approach. The stories around the maps are critical, and if removed from the discussion, system maps can appear abstract and impersonal. Moreover, they can challenge people to take more responsibility for the current system than they are prepared to or deem necessary (Stroh, 2015).

Limitations in the ABM

ABMs are inherently bottom-up and decentralized, and its main advantage is its ability to capture emergence, and link individual behavior to system level behaviors. However, there is often a lack of individual-level data to inform the model and characterize the relevant processes, or the data require more advanced mathematical/statistical skills to convert existing data to distributions and proportions or to extract data from survey data. Useful Data is often in a side comment in an article that pertains to an exception. This poses a problem for building models grounded in the literature or real world situations, and can require a very time consuming process to resolve. And yet initial conditions can have important influence on model behavior and provide validation of the representation it provides. My limited experience in the field suggests that some people are still looking to ABMs for prediction, and are less enamored with their use as “thinking prostheses”, with a focus on the modeling process rather than just the outcomes.

Limitations in the DES

There are few limitations of the DES models when applied to systems like the dental care process. Intended for industrial production, it works well for this purpose. As it is most used in

industry, software is often expensive and technical. In my model, several aspects of the representation of the caries process have been simplified for modeling purposes, and likely limit the application of the results. This includes use of a single care protocol (fluoride varnish) rather than multiple protocols. How much fluoride is needed to remineralize a lesion will vary from patient to patient; we standardized this to four visits. A silver diamine protocol requires only one or two applications; introducing an alternate protocol may substantially alter results.

Directions for Future Research

Modeling is about learning, and when our predictions are shown to be incorrect, we can go back and study our model in detail and make improvements, continually enhancing and enriching our understanding. ABMs are extremely flexible. Though it can at times be a disadvantage — one can spend inordinate time refining the model structure — it is beneficial when it comes to extending the model utility for future research. This model was especially designed with this in mind, allowing adaptation to explore new questions. With some enhancements to the care process (resources, time constraints, etc.) and further calibration of the disease process (perhaps using dmft/dmfs), the model could be adapted to several related areas of interest to the dental and public health fields.

The dental field is keen on finding more efficient and cost-controlling delivery models that minimize capital expenses (use of the workforce) while maximizing oral health outcomes. This might include different staffing models within dental practices (number of DAs, DHs, or use of spaces/chairs). Extending this model to account for procedure and staffing costs, revenues, and profits would give providers, payers, and policymakers a better appreciation for the effects of workforce, clinical approach, and its interaction with payment mechanisms. Inter-professional

strategies between medical and dental, general dentist and pediatric dentist, dentist and community programs could be explored.

Another application is around disparities and behaviors surrounding oral health and dental care. Right now many of the actions of patients and providers are determined exogenously, following either a protocol or schedule. Making care-seeking endogenous to the agents would allow for a more nuanced and realistic model to account for factors motivating care seeking such as trust and social network influences (as suggested in (Kreuger et al., 2017), cost, or a person's internal resources to cope with challenging life situations("levers and filters" principle proposed by Harris et al. 2017). Similarly incorporating provider decision making and learning would. This would help broaden our understanding of the mechanisms and structures involved.

Finally, there may be opportunities to collaborate with public health officials to adapt the model to explore areas of particular interest to either county, or state, or health services agencies, particularly for other chronic conditions. This might also make data generally not available to inform various levels of the model. All of these extensions have the potential to further improve our understanding of the systems in our world and give possible ways to navigate policy making through evidence-based research and findings.

System science breeds habit of mind that can lead to more transparent and open discussions of the causes and consequences of complex problems. It allows us to capture the dynamic aspects of complex system structures that influence behaviors at various levels of aggregation, with feedbacks and interactions that change over time. It can be an effective communication tool providing visual representation of processes and outputs in order to communicate with experts and stakeholders alike. It will also foster interdisciplinary collaboration and discussion of complex policy problems.

Appendix 1: Complex System Methods and Examples

System dynamics models

System dynamics has a simplicity to it that makes it a good tool to involve stakeholders and policymakers in discussions leading to policy decisions. There are two major assumptions of system dynamics models. The first is random mixing within populations (and often across the entire population, i.e., everyone mixes with everyone). In reality, people assort non-randomly, based on demographics, social connections and geographic proximity. But this assumption is generally acceptable in large-scale models. The other assumption is that they take place in large populations where the role of randomness and particular events can be ignored. Models can therefore be deterministic if they ignore randomness, or models can take into account a degree of randomness, and are referred to as stochastic models (El-Sayed & Galea, 2017). While limited in its ability to represent human interactions, SD's are computationally approachable and flexible and have demonstrated remarkable power in providing insights into the dynamics of both infectious and noninfectious diseases. What is particularly powerful about SD is that parameters like duration of infection and contact rates (to represent different levels of crowding) can be changed interactively. SD is also amenable to describing more abstract concepts, like an amount of "self-efficacy."

Some examples of the health problems that system dynamics has been used to study include (from Milstein & Homer, 2006) the following:

- cardiovascular disease (Hirsch and Wils, 1984; Homer, Hirsch, Minniti, et.al., 2004; Luginbuhl and Hirsch, 1981)
- cervical cancer (Royston, Dost, Townshend, et.al., 1999)
- chlamydia (Royston, Dost, Townshend, et.al., 1999; Townshend and Turner, 2000)
- cocaine addiction (Homer, 1993)
- coastal waters (Brinks et al., 2008; Turbow, Osgood, & Jiang, 2003)
- dengue fever (Ritchie-Dunham and Mendez Galvan, 1999)
- diabetes (Homer, Hirsch, Minniti, et.al., 2004; Homer, Jones, Seville, et.al., 2004; Jones, Homer, Murphy, et.al., 2006); and (Osgood, Dyck, & Grassmann, 2011; Zhang, Osgood, Grassmann, & Dyck, n.d.)
- dental care (Hirsch and Killingsworth, 1975; Levin and Roberts, 1976)
- drug-resistant pneumococcal infections (Homer, Ritchie-Dunham, Rabbino, et.al., 2000)
- health care reform (Hirsch, Homer, McDonnell, et.al., 2005)
- heroin addiction (Levin, Roberts, Hirsch, 1975)
- H1N1 influenza (Hashemian, Stanley, & Osgood, 2012; Safarishahrbijari et al., 2015)
- HIV/AIDS (Dangerfield, Fang, Roberts, 2001; Homer and St. Clair, 1991; Roberts and Dangerfield, 1990)
- HMO planning (Hirsch and Miller, 1974)
- mammography (Fett, 2001)
- mental health (Levin and Roberts, 1976; Smith, Wolstenholme, McKelvie, et.al., 2004)

- obesity (Abdel-Hamid, 2002, 2003; Homer, Milstein, Dietz, et.al., 2006); (Dyck, Osgood, Gao, & Stang, 2012; Sabounchi, Hovmand, Osgood, Dyck, & Jungheim, 2014)
- patient flows (Lane, Monfeldt, Rosenhead, 2000; Wolstenholme, 1996, 1999)
- performance assessment (McDonnell, Heffernan, Faulkner, 2004)
- public health emergencies (Hirsch, 2004; Hoard, Homer, Manley, et al., 2005)
- public health planning (Hirsch and Immediato, 1999; Hirsch and Immediato, 1998; Homer and Milstein, 2004; Innovation Associates and New England Health Care Assembly, 1997)
- tobacco addiction (National Cancer Institute, 2005; Roberts, Homer, Kasabian, et.al., 1982; Tengs, Ahmad, Savage, et.al., 2005; Tengs, Osgood, Chen, 2001; Tengs, Osgood, Lin, 2001); and control
- syndemics (Homer and Milstein, 2002, 2003b, 2004)

Agent-based models

The main benefits and utility of ABMs is that they capture emergent phenomena, provide a natural description of a system, and are flexible. Agent-based modeling is a particularly promising systems science approach to model complex interactions and processes related to chronic health conditions, such as adaptive behaviors, feedback loops, and contextual effects. (Li, 2016). Hammond (2015) outlines three categories of models that are used to inform policy and decision-making: prospective, retrospective, and indirect policy models. Prospective models help to inform the design of policies or interventions by bringing to light their potential effects. Retrospective models help researchers understand the underlying reasons for the success or failure of a policy/intervention already in place. The indirect models are not explicitly aimed at considering policy choices, but their focus on understanding etiology, and explaining relationships between system structure and individual behavior over time, as well as pathways that cross levels of scale, have important implications for policy choices (Hammond, 2015; Kaplan et al., 2017). The model developed in this dissertation falls in this last category.

Some of the problems ABM has been use to study in health and health care include the following:

- Obesity prevention, Income inequalities in diet and residential segregation (Auchincloss & Garcia, 2015; Auchincloss, Riolo, Brown, Cook, & Diez Roux, 2011)
- Diabetes epemiology (Dyck et al., 2012; Osgood, Dyck, et al., 2011)
- Diabetic retinopathy (Day, Ravi, Xian, & Brugh, 2013)
- Tobacco regulation (Wallace, Geller, & Ayano, 2015) (Wallace 2015) and smoling behavior
- Improving quality of care (Kanagarajah 2010)
- Place effects on health (Auchincloss & Diez Roux, 2008)
- Clinical systems (Keykum, 2012)
- Vaccination coverage
- Hospitals and emergency department workflow (Wi, 2009)
- Noncommunicable diseases (Nianogo & Arah, 2015)
- Tuberculosis and contact tracing (Osgood, Mahamoud, et al., 2011; Tian & Osgood, n.d.)

Discrete event simulations

A systematic review of health-care simulation by Fone et al. (Fone et al., 2003) revealed that most models were conducted at a micro level versus whole-system models, i.e., detailed aspects of a hospital such as emergency departments, operating theaters, outpatient departments or inpatient wards, and intensive care units. A review by Jun et al. (Jun, Jacobson, & Swisher, 1999) categorized models published in the three decades until 1999 into those that focused on scheduling and patient flow, sizing and planning of beds, rooms and staff, and a discussion of future research areas.

DES vs. Markov models For those unfamiliar with DES model, they might appear quite similar to its better known cousin, the Markov chain model. Indeed they share some features, but differ in their ability to capture more complex and dynamic processes. While Markov models require fewer resources with regards to input data and model development, DES models have some advantages in its ability to build more complex and dynamic representations of the system being modeled. Some of the main differences are as follows (L. B. Standfield, Comans, & Scuffham, 2017; L. Standfield, Comans, & Scuffham, 2014):

- A DES model is triggered by the occurrence of an event, at which point the model asks what is and when is the next event for a patient, whereas a Markov process asks what events are occurring at regular intervals.
- The ability to keep track of individual biographies and histories: The Markov principle requires the next state to be linked only to the current state, and independent of previous states. In dynamic models and human systems, both biological and social, this is rarely the case.
- The ability to accommodate complexity and uncertainty and represent interdependencies: In Markov models, states are independent— one cannot be in more than one state at a time. Therefore, in order to consider these conditions, one must think a priori of all the combination of possible states and transitions, sometimes making for massive decision trees.
- DES can model competing risk whereas this is most difficult in Markov models.
- Changing parameters and probabilities. Markov models are more static, and are not set up to test changes in parameters and probabilities.
- Representing time flexibly: DES has the ability to model delays and queues and differences in times between events, which in Markov models is invariant.
- DES has the ability to model queuing for limited resources, while Markov models cannot (L. Standfield et al., 2014). Often consideration of the length and waiting time for such queues is of central interest in Markov models.

Applications of discrete event simulations include the following:

- Medical decision modeling (Jahn, Theurl, Siebert, & Pfeiffer, 2010)
- HIV (Simpson, Strassburger, Jones, Dietz, & Rajagopalan, 2009)
- Resource tasks (Baril, Gascon, Miller, & Bounhol, 2017)
- Caries process – finite absorbing Markov chains (Lu, 1966)
- Access time outpatient departments (Elkhuizen, Das, Bakker, & Hontelez, 2007)
- Resource allocation (Bayer, 2014)
- Human behavior in HC systems (Brailsford & Schmidt, 2003)

- Physician clinic environment (Swisher, Jacobson, Jun, & Balci, 2000)
- Health economic evaluation (Caro, Möller, & Getsios, 2010)
- Emergency department efficiency (Bair, Song, Chen, & Morris, 2010), process improvement (Choon, Dali, Beng, & Magdalene, 2014) and patient experience (Abo-Hamad & Arisha, 2013)
- Surgery patient flow and communication (Taaffe, Fredendall, Huynh, & Franklin, 2015) (Taaffe 2015), preoperative hospital environment (Pearce, Hosseini, Taaffe, Huynh, & Harris, 2010)
- Clinic flow (Swisher, Jacobson, Jun, & Balci, 2001)

Hybrid Models are less common in the literature, but they maximize the strengths of each of the methods they use. Here are some examples:

- Diabetic retinopathy screening (Day, Ravi, Xian, & Brugh, 2014)
- Chlamydia (Vickers & Osgood, 2014; Vickers, Zhang, & Osgood, 2009)
- Diabetic end stage renal disease (Gao et al., 2014; Gao, Osgood, Jiang, & Dyck, 2017)
- Oral health disparities and dental care (Kreuger et al., 2017)

Appendix 2: State Charts

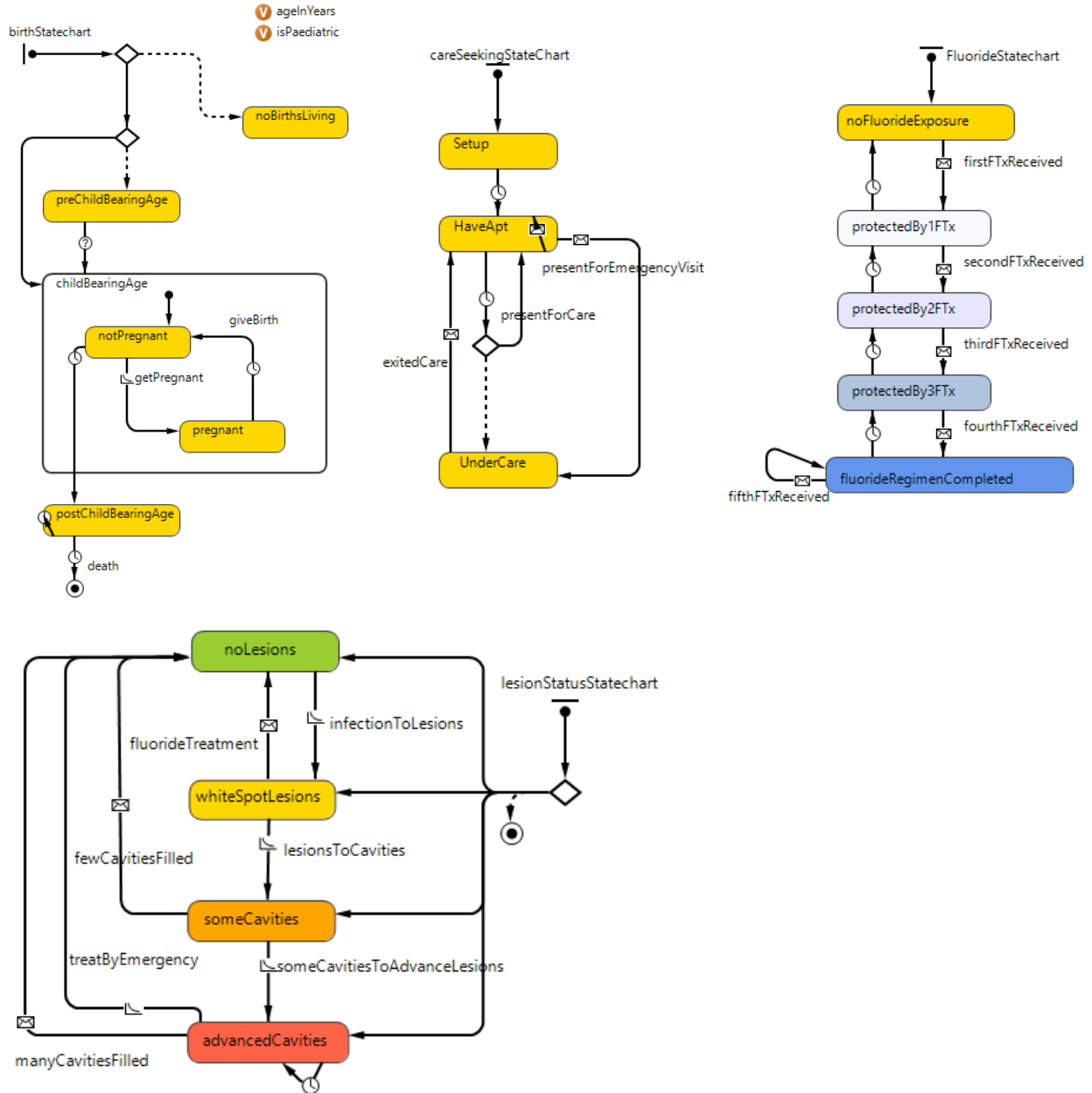

Care seeking, Fluoride and Lesion Development

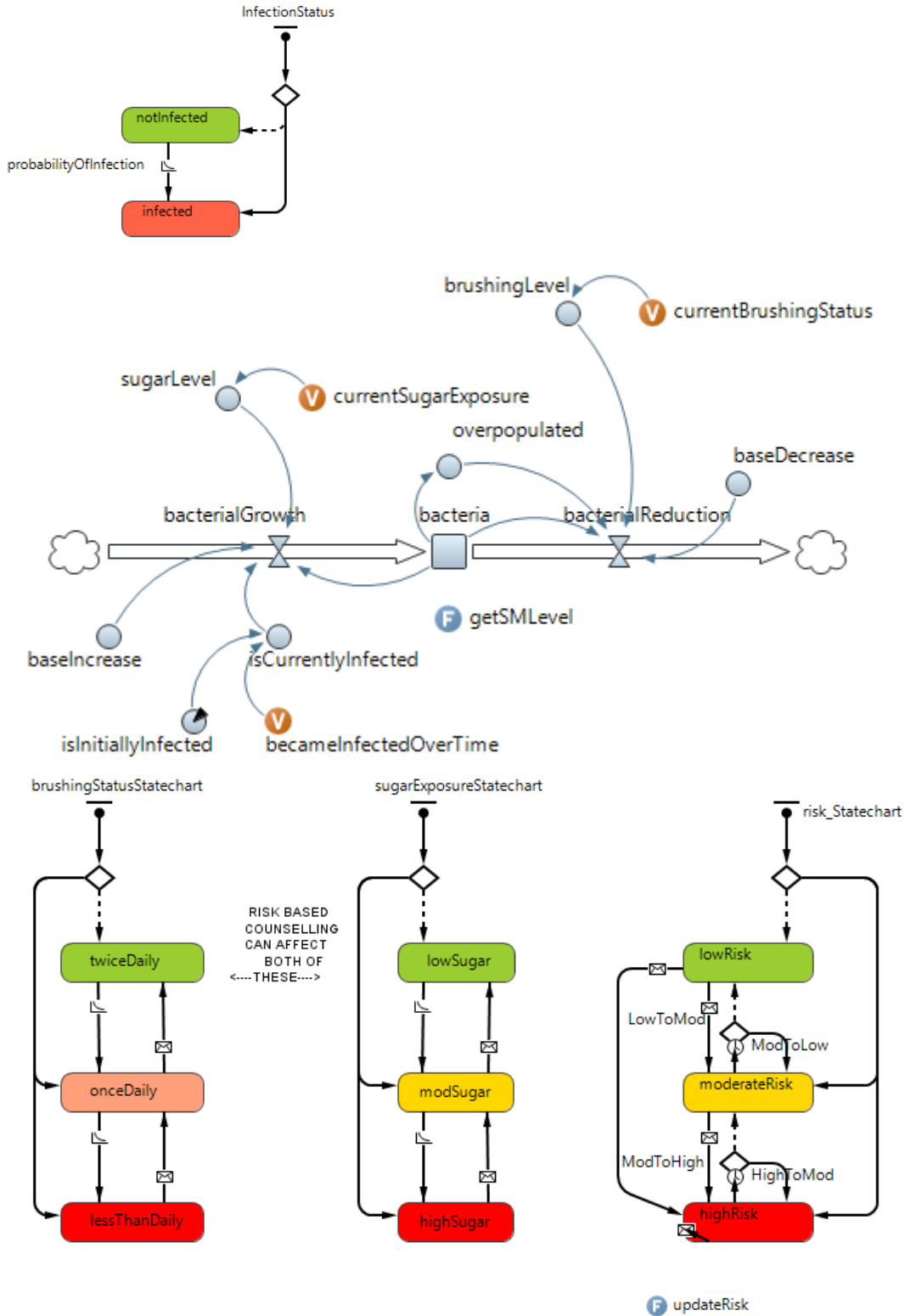

Bacteria SD Model

Appendix 3: Questions That Aided and Informed the Model Development

- What is the etiology of caries? Multifactorial, bacterial, transmissible, chronic
- What initiates it? Where does it come from?
- Vertical transmission of mutans streptococci (MS) bacteria from mother to infant
- What circumstances affects the probability of this vertical transmission?
- Higher coliform counts of caries causing bacteria in the mother increase the likelihood of the child acquiring the bacteria. Thresholds of 10^6 CFU/ml have been found to pose significant risk to the child.
- What disease states are associated with these high levels of caries causing bacteria?
- More and more severe cavities.
- White spot lesions are the first indication but fewer statistics exist on the prevalence of these lesions.
- What drives the caries process? Once the child is inoculated with the bacteria, what causes them to grow, develop and cause lesions on the teeth?
- Sugar exposure. Sugar doesn't just feed the bacteria it also provides the substrate for the production of glycans and glycoproteins which provide the mechanism for the formation of plaque and its adherence to the tooth. The frequency and the type of exposure are also important.
- Low pH. SM thrive in an acidic environment
- Plaque build up
- What can minimize bacteria growth and/or protect teeth? And how?
- Toothbrushing and dental cleanings remove plaque buildup which demineralizes the tooth
- Fluoride strengthens the tooth enamel by remineralizing and counteracting the effects of the plaque. This can be in the form of toothpaste or varnish.
- Calcium phosphate helps reduce demineralization as well
- How much is needed?
- Toothbrushing — recommendation is at least twice a day with fluoridated toothpaste. Studies show a link between frequency and disease.
- Fluoride/Ca PO_4 depends on the level of risk and behaviors
- Cleaning — depends on level of plaque buildup
- How does dental care interact with this disease process?
- Cleanings will remove plaque and reduce the amount of bacteria in the mouth
- Restorations also remove buildup of bacteria and scope out plaque housed within the structure of tooth
- Bacteria in the mouth is not eliminated but is reduced
 - Behaviors that caused buildup of bacteria and plaque can be influenced but are not automatically affected by a dental visit.

Appendix 4: AnyLogic Model Screens

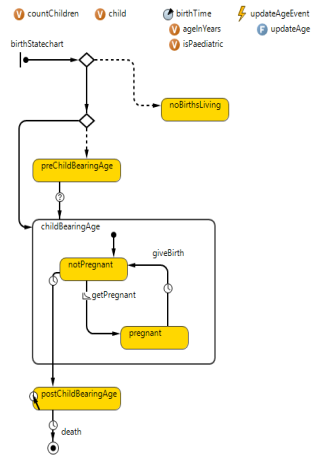
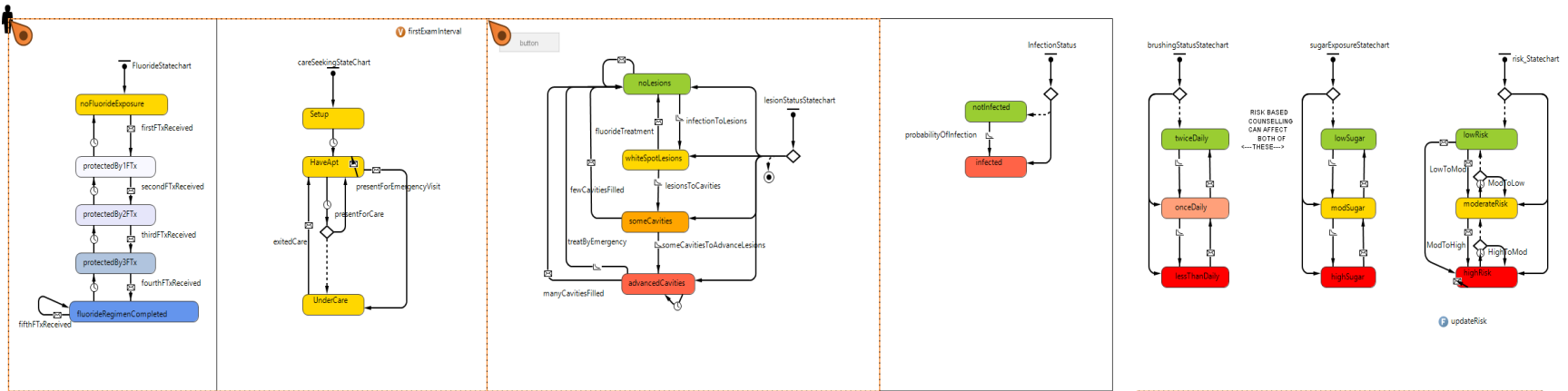

General parameters & Values

- id
- mother
- riskBasedOrTraditionalClinic
- getClinicType

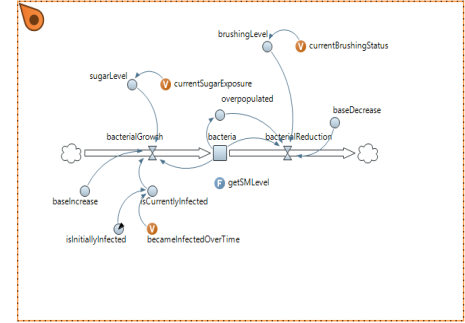

Appendix 5: Calibration of the Lesion Development Hazard

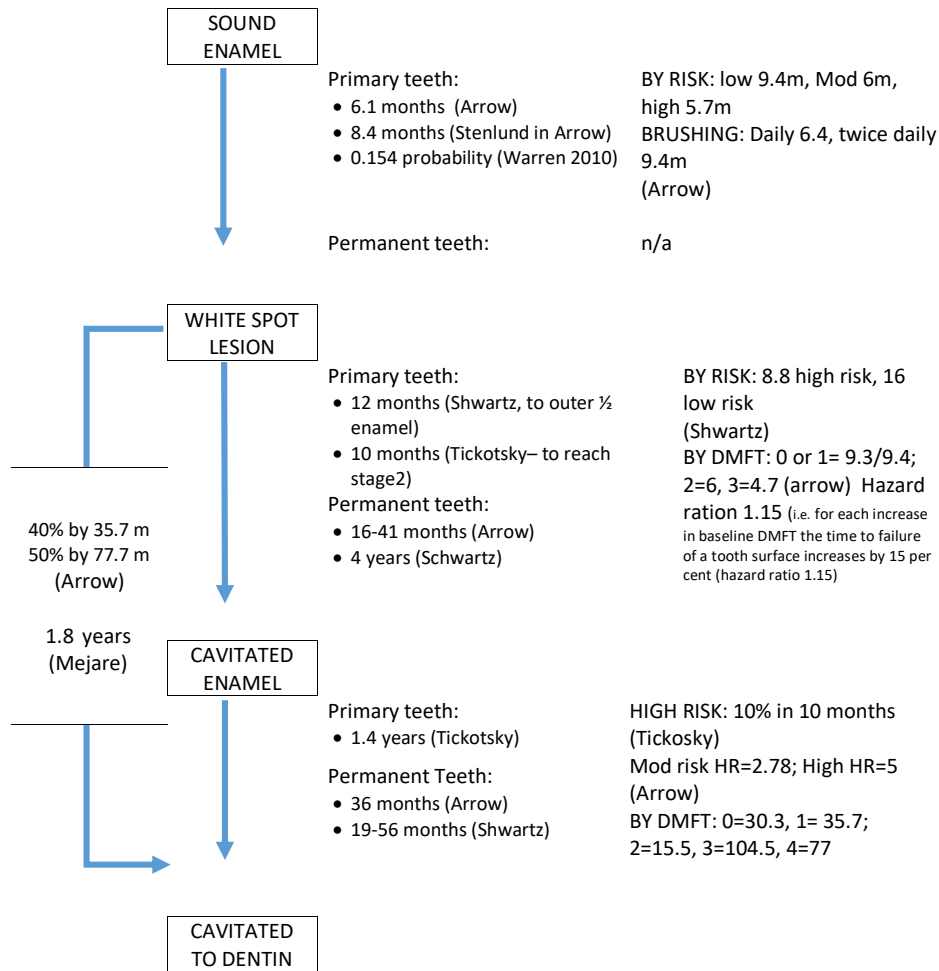

Information used to calibrate transitions between lesion states (Arrow, 2007; Mejàre et al., 2015; Shwartz et al., 1984; Tickotsky et al., 2017)

$$h = h_0 * \exp(\beta_{SM} \times \log(\text{BacterialLevel})) + (\beta_{Fluoride} \times \text{RelativeFluorideLevel}) + (\beta_{brushing} \times \text{Toothbrushing}) + 1.5 \text{ (child)}$$

CHILD - VERY high risk

base hazard rate coefficient by State	Transition Rates	rate in months	rate in years
From No lesion	1.2	4.880	2.5
From WSL	0.7	2.847	4.2
From Some Cavities	0.5	2.033	5.9

HIGH RISK

Transition Rates	rate in months	rate in years
3.996	3.0	0.3
2.331	5.1	0.4
1.665	7.2	0.6

MODERATE

Transition Rates	rate in months	rate in years
0.985	12.2	1.0
0.575	20.9	1.7
0.411	29.2	2.4

LOW RISK

Transition Rates	rate in months	rate in years
0.660	18.2	1.5
0.385	31.1	2.6
0.275	43.6	3.6

VERY LOW RISK

Transition Rates	rate in months	rate in years
0.297	40.4	3.4
0.173	69.3	5.8
0.124	97.0	8.1

Beta	input	hazard term
bacteria	0.3	10,000,000
fluoride	-0.15	0
brushing	-0.2	0
primary teeth	1.2	1
Base Hazard	0.15	1.2

Lesion Development Hazard = **4.07**

Beta	input	hazard term
0.3	10,000,000	2.10
-0.15	0	0
-0.2	1	-0.2
1.2	1	1.2
0.15	0.15	0.15

Lesion Development Hazard = **3.33**

Beta	input	hazard term
0.3	100,000	1.50
-0.15	4	-0.6
-0.2	2	-0.4
1.2	1	1.2
0.15	0.15	0.15

Lesion Development Hazard = **0.82**

Beta	input	hazard term
0.3	1,000	0.90
-0.15	4	-0.6
-0.2	1	-0.2
1.2	1	1.2
0.15	0.15	0.15

Lesion Development Hazard = **0.55**

Beta	input	hazard term
0.3	1,000	0.90
-0.15	8	-1.2
-0.2	2	-0.4
1.2	1	1.2
0.15	0.15	0.15

Lesion Development Hazard = **0.25**

ADULT - VERY high risk

Transition Rates	rate in months	rate in years
1.470	8.2	0.7
0.857	14.0	1.2
0.612	19.6	1.6

HIGH RISK

Transition Rates	rate in months	rate in years
1.036	11.6	1.0
0.604	19.9	1.7
0.432	27.8	2.3

MODERATE

Transition Rates	rate in months	rate in years
0.297	40.4	3.4
0.173	69.3	5.8
0.124	97.0	8.1

LOW RISK

Transition Rates	rate in months	rate in years
0.199	60.3	5.0
0.116	103.4	8.6
0.083	144.8	12.1

VERY LOW RISK

Transition Rates	rate in months	rate in years
0.089	134.3	11.2
0.052	230.1	19.2
0.037	322.2	26.9

Beta	input	hazard term
0.3	10,000,000	2.10
-0.15	0	0
-0.2	0	0
1.2	0	0
0.15	0.15	0.15

Lesion Development Hazard = **1.22**

Beta	input	hazard term
0.3	10,000,000	2.10
-0.15	1	-0.15
-0.2	1	-0.2
1.2	0	0
0.15	0.15	0.15

Lesion Development Hazard = **0.86**

Beta	input	hazard term
0.3	100,000	1.50
-0.15	4	-0.6
-0.2	2	-0.4
1.2	0	0
0.15	0.15	0.15

Lesion Development Hazard = **0.25**

Beta	input	hazard term
0.3	1,000	0.90
-0.15	4	-0.6
-0.2	1	-0.2
1.2	0	0
0.15	0.15	0.15

Lesion Development Hazard = **0.17**

Beta	input	hazard term
0.3	1,000	0.90
-0.15	8	-1.2
-0.2	2	-0.4
1.2	0	0
0.15	0.15	0.15

Lesion Development Hazard = **0.07**

INPUT TERMS

BRUSHING

- Less than Once 0.25
- Once Daily 1
- Twice Daily 2

FLUORIDE

- no fluoride 0
- 1 F Tx 2
- 2 F Tx 4
- 3 F Tx 6
- 4 F Tx 8

Appendix 6: Calculation of Functional Risk Distributions Simulation Model

The target for the initial risk distribution is 65% low risk, 25% moderate and 10% high risk. The model was not initializing with that distribution. The figures below explain the logic and mathematical calculations that instead resulted in a functional distribution of 49.5% high risk, 11.25% moderate and 39.25 % low risk.

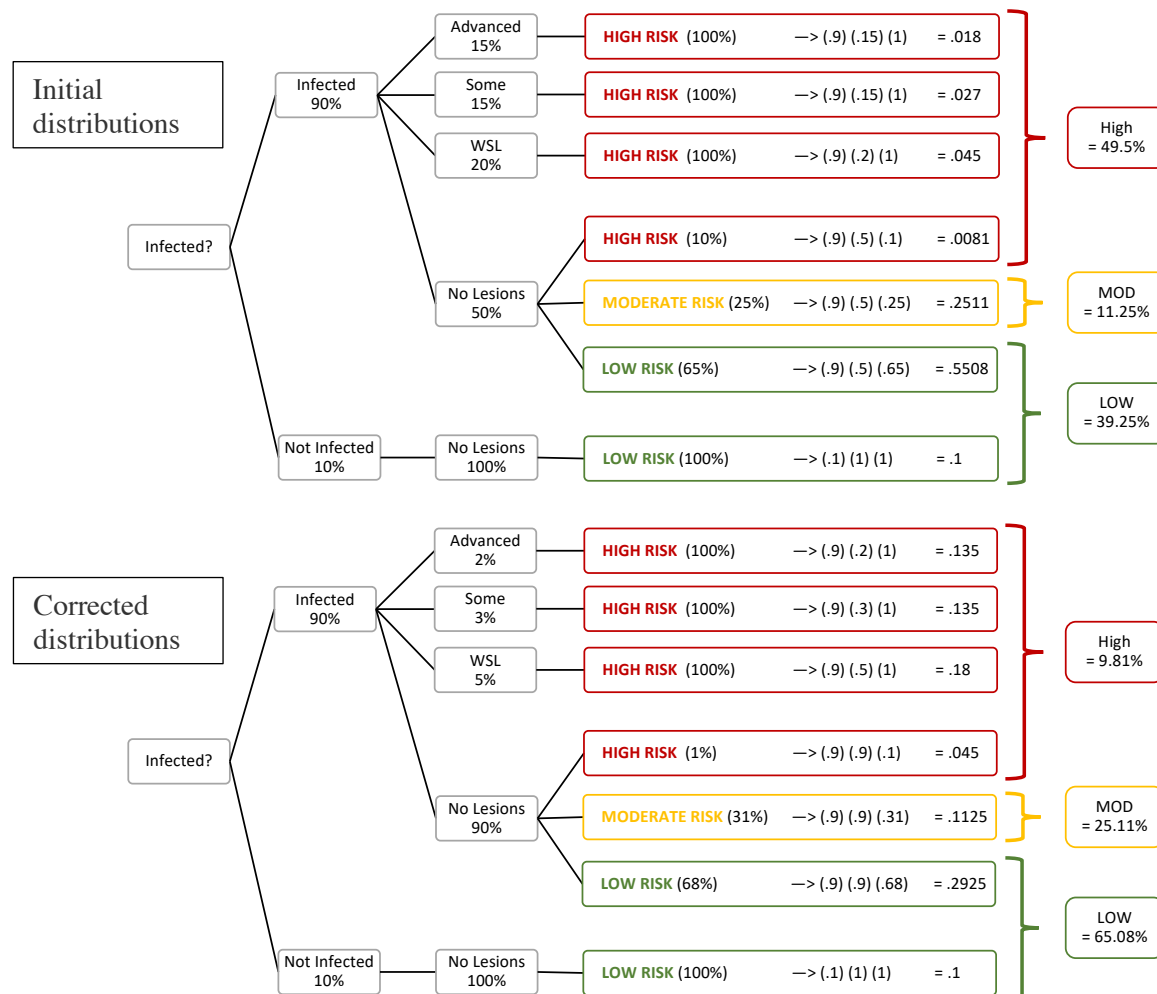

AnyLogic has to assign characteristics in an order, and in this case assigns them in this order:

1. Determine percent infected, then of those that are infected,
2. A distribution of lesion states applies. Anyone with lesions will be high risk.
3. Those that do not have lesions can be in any risk status — AnyLogic uses the risk distribution to categorize this group.

Thus I had to adjust the percentages for the initial distribution of risk and lesion states in order to obtain the desired functional distribution. Figure B shows how a distribution of lesion states to 90% for no lesions, 5% WS Lesions, 3% Some Cavities, and 2% advanced cavities, combined with a risk distribution of 68% low, 31% moderate and 1% high; this yields a final risk distribution of 65%-25%-10%, for low, moderate and high risk respectively.

References

- Aas, J. A., Paster, B. J., Stokes, L. N., Olsen, I., & Dewhirst, F. E. (2005). Defining the normal bacterial flora of the oral cavity. *Journal of Clinical Microbiology*, 43(11), 5721–32. <http://doi.org/10.1128/JCM.43.11.5721-5732.2005>
- Abanto, J., Celiberti, P., Braga, M. M., Vidigal, E. A., Cordeschi, T., Haddad, A. E., & Bönecker, M. (2015). Effectiveness of a preventive program based on caries risk assessment and recall intervals on the incidence and regression of initial caries lesions in children. *International Journal of Paediatric Dentistry*, 25(4), 291–299. <http://doi.org/10.1111/ipd.12144>
- Abo-Hamad, W., & Arisha, A. (2013). Simulation-based framework to improve patient experience in an emergency department. *European Journal of Operational Research*, 224(1), 154–166. <http://doi.org/10.1016/j.ejor.2012.07.028>
- Abreu, L. G., Elyasi, M., Badri, P., Paiva, S. M., Flores-Mir, C., & Amin, M. (2015). Factors associated with the development of dental caries in children and adolescents in studies employing the life course approach: a systematic review. *European Journal of Oral Sciences*, 123(5), 305–311. <http://doi.org/10.1111/eos.12206>
- ADA. (2012). 2012 Survey of Dental Practice Pediatric Dentists in Private Practice CHARACTERISTICS REPORT. Retrieved from <http://www.aapd.org/assets/1/7/SurveyofDentalPracticeReport.pdf>
- ADA Council on Scientific Affairs. (2006). Professionally applied topical fluoride Evidence-based clinical recommendations. *JADA*, 137. Retrieved from http://www.ada.org/~media/ADA/Science and Research/Files/report_fluoride.ashx
- ADA Health Policy Institute. (2015). *Dental Benefits Coverage in the U.S.* Retrieved from https://www.ada.org/~media/ADA/Science and Research/HPI/Files/HPIgraphic_1117_3.pdf?la=en
- ADA Health Policy Institute. (2017a). *Dental Care Utilization in the U.S.* Retrieved from https://www.ada.org/~media/ADA/Science and Research/HPI/Files/HPIgraphic_1117_2.pdf?la=en
- ADA Health Policy Institute. (2017b). Emergency Department Visits for Dental Conditions – A Snapshot (Infographic). Retrieved from http://www.ada.org/~media/ADA/Science and Research/HPI/Files/HPIgraphic_0617_3.pdf?la=en
- ADA Health Policy Institute. (2017c). *Racial and Ethnic Diversity among Dentists in the U.S.* Retrieved from https://www.ada.org/~media/ADA/Science and Research/HPI/Files/HPIgraphic_1117_6.pdf?la=en
- ADA Health Policy Institute. (2017d). *Untreated Caries Rates Falling Among Low-Income Children.* Retrieved from http://www.ada.org/~media/ADA/Science and Research/HPI/Files/HPIgraphic_0617_2.pdf?la=en
- ADA Health Policy Institute. (2018). *Dentist Participation in Medicaid or CHIP.* Retrieved from https://www.ada.org/~media/ADA/Science and Research/HPI/Files/HPIgraphic_0318_1.pdf?la=en
- ADA HPI. (2017). *Supply of Dentists in the U.S.: 2001-2016.* Retrieved from <http://www.ada.org/en/science-research/health-policy-institute/data-center/supply-of-dentists>
- Adair, P. M., Pine, C. M., Burnside, G., Nicoll, A. D., Gillett, A., Anwar, S., ... Freeman, R. (2004). Familial and cultural perceptions and beliefs of oral hygiene and dietary practices among ethnically and socio-economically diverse groups. *Community Dental Health*, 21, 102–111. Retrieved from

http://www.who.int/oral_health/media/en/orh_cdh_0304_08_familial.pdf

- Alaluusua, S., & Renkonen, O. V. (1983). Streptococcus mutans establishment and dental caries experience in children from 2 to 4 years old. *Scandinavian Journal of Dental Research*, 91(6), 453–7. Retrieved from <http://www.ncbi.nlm.nih.gov/pubmed/6581521>
- Allareddy, V., Nalliah, R. P., Haque, M., Johnson, H., Rampa, S. B., & Lee, M. K. (2014). Hospital-based Emergency Department Visits with Dental Conditions among Children in the United States: Nationwide Epidemiological Data. *Pediatric Dentistry*, 36(5), 393–399. Retrieved from <http://www.ingentaconnect.com/content/aapd/pd/2014/00000036/00000005/art00006>
- Allareddy, V. V., Rampa, S., Lee, M. K., Allareddy, V. V., P.Nalliah, R., & Nalliah, R. P. (2014). Hospital-based emergency department visits involving dental conditions: Profile and predictors of poor outcomes and resource utilization. *The Journal of the American Dental Association*, 145(4), 331–337. <http://doi.org/10.14219/JADA.2014.7>
- American Academy of Pediatric Dentistry. (2008). Definition of Early Childhood Caries (ECC). Retrieved from http://www.aapd.org/assets/1/7/D_ECC.pdf
- American Academy of Pediatric Dentistry (AAPD). (n.d.). *Early Childhood Caries (ECC)*. Retrieved from <http://www.mychildrensteeth.org/assets/2/7/ECCstats.pdf>
- American Academy of Pediatric Dentistry (2017). *Use of Silver Diamine Fluoride for Dental Caries Management in Children and Adolescents, Including Those with Special Health Care Needs*. Retrieved from http://www.aapd.org/media/Policies_Guidelines/G_SDF.pdf
- American Academy of Pediatric Dentistry). (2015a). Guideline on Caries-risk Assessment and Management for Infants, Children, and Adolescents. *Clinical Guidelines, Reference Manual 2015-2016*, 37(6), 132–139. Retrieved from http://www.aapd.org/media/policies_guidelines/g_cariesriskassessment.pdf
- American Academy of Pediatric Dentistry (AAPD). (2015b). Guideline on Periodicity of Examination, Preventive Dental Services, Anticipatory Guidance/Counseling, and Oral Treatment for Infants, Children, and Adolescents. *Clinical Guidelines, Reference Manual 2015-2016*, 37(6), 123–130. Retrieved from http://www.aapd.org/media/Policies_Guidelines/BP_Periodicity.pdf
- American Academy of Pediatric Dentistry (AAPD). (2015). Policy on the dental home. *Pediatric Dentistry*, 30(7 Suppl), 22–23. Retrieved from http://www.aapd.org/media/policies_guidelines/p_dentalhome.pdf
- American Academy of Pediatrics. (2003). Policy Statement. Oral Health Risk Assessment Timing and Establishment of the Dental Home. *Pediatrics*, 111(2), 426–435. <http://doi.org/10.1542/peds.2005-1877>
- American Academy of Pediatrics. (2014). Policy Statement Maintaining and Improving the Oral Health of Young Children. *Pediatrics*, 134, 1224–1229. <http://doi.org/10.1542/peds.2014-2984>
- American Association of Public Health Dentistry. (2004). First Oral Health Assessment Policy. Retrieved March 31, 2018, from <http://www.aaphd.org/oral-health-assessment-policy>
- American Dental Association. (2000). Statement on Early Childhood Caries. Retrieved March 31, 2018, from <https://www.ada.org/en/about-the-ada/ada-positions-policies-and-statements/statement-on-early-childhood-caries>
- American Dental Association. (2014). Taking care of your child’s smile. *JADA*, 145(5), 504. Retrieved from <https://www.ada.org/~media/ADA/Publications/Files/ForthePatient-0514.pdf?la=en>
- American Dental Association. (2016). *Quality Measurement in Dentistry - A Guidebook*. Retrieved from

[http://www.ada.org/~media/ADA/Science and Research/Files/DQA_2016_Quality_Measurement_in_Dentistry_Guidebook.pdf?la=en](http://www.ada.org/~media/ADA/Science_and_Research/Files/DQA_2016_Quality_Measurement_in_Dentistry_Guidebook.pdf?la=en)

American Dental Association (ADA). (2018). *Supply of Dentists in the U.S. 2001-2017. HPI File.*

American Dental Association Council on Dental Therapeutics. (1960). Evaluation of Crest toothpaste. *JADA*, *61*, 272–274.

American Dental Education Association. (2017). Dental Student Debt. Retrieved April 3, 2018, from http://www.adea.org/GoDental/Money_Matters/Educational_Debt.aspx

Andersen, R. M. (1995). Revisiting the Behavioral Model and Access to Medical Care: Does it Matter? *Journal of Health and Social Behavior*, *36*(1), 1–10. <http://doi.org/10.2307/2137284>

Andersen, R. M. (2008). National health surveys and the behavioral model of health services use. *Medical Care*, *46*(7), 647–653. Retrieved from http://journals.lww.com/lww-medicalcare/Abstract/2008/07000/National_Health_Surveys_and_the_Behavioral_Model.2.aspx

Andersen, R. M., & Davidson, P. L. (2007). Improving Access to Care in America: Individual and Contextual Indicators. In & G. F. K. R. M. Andersen, T. H. Rice (Ed.), *Changing the U.S. health care system: Key issues in health services policy and management* (3rd ed., pp. 3–31). Sam Francisco, CA. Retrieved from <http://psycnet.apa.org/record/2007-01621-001>

Andersen, R. M., & Davidson, P. P. L. (1997). Ethnicity, Aging, and Oral Health Outcomes: A Conceptual Framework. *Advances in Dental Research*, *11*(2), 203–209. <http://doi.org/10.1177/08959374970110020201>

Anderson, K. L., Self, T. L., & Carlson, B. N. (2017). Interprofessional Collaboration of Dental Hygiene and Communication Sciences & Disorders Students to Meet Oral Health Needs of Children with Autism. *Journal of Allied Health*, *46*(4), e97–e101. Retrieved from <http://www.ncbi.nlm.nih.gov/pubmed/29202172>

Andrews, M. (2015). Adults With Insurance Often Still Have Unmet Dental Needs, Survey Finds | Kaiser Health News. Retrieved April 8, 2018, from <https://khn.org/news/adults-with-insurance-often-still-have-unmet-dental-needs-survey-finds/>

AnyLogic. (2015). *Simulation Software Comparison*. Retrieved from <https://www.anylogic.com/upload/iblock/fd4/fd4d353e5afbbdf421ff4efea586373c.pdf>

Arevalo, O., Saman, D. M., & Rohall, V. (2011). Measuring clinical productivity in community-based dental education programs. *Journal of Dental Education*, *75*(9), 1200–7. Retrieved from <http://www.ncbi.nlm.nih.gov/pubmed/21890849>

Arrow, P. (2007). Incidence and progression of approximal carious lesions among school children in Western Australia. *Australian Dental Journal*, *52*(3), 216–226. Retrieved from <https://onlinelibrary.wiley.com/doi/pdf/10.1111/j.1834-7819.2007.tb00492.x>

Arvidsson, L., Birkhed, D., Hunsberger, M., Lanfer, A., Lissner, L., Mehlig, K., ... McGovern, P. (2016). BMI, eating habits and sleep in relation to salivary counts of mutans streptococci in children – the IDEFICS Sweden study. *Public Health Nutrition*, *19*(06), 1088–1092. <http://doi.org/10.1017/S1368980015002347>

Asoulin, E. (2016). Language as an instrument of thought. *Glossa: A Journal of General Linguistics*, *1*(1), 1–23. <http://doi.org/10.5334/gjgl.34>

Auchincloss, A. H., & Diez Roux, A. V. (2008). A new tool for epidemiology: The usefulness of dynamic-agent models in understanding place effects on health. *American Journal of Epidemiology*. <http://doi.org/10.1093/aje/kwn118>

- Auchincloss, A. H., & Garcia, L. M. T. (2015). Brief introductory guide to agent-based modeling and an illustration from urban health research. *Cadernos de Saúde Pública*, *31*(suppl 1), 65–78. <http://doi.org/10.1590/0102-311X00051615>
- Auchincloss, A. H., Riolo, R. L., Brown, D. G., Cook, J., & Diez Roux, A. V. (2011). An agent-based model of income inequalities in diet in the context of residential segregation. *American Journal of Preventive Medicine*, *40*(3), 303–311. <http://doi.org/10.1016/j.amepre.2010.10.033>
- Autio-Gold, J. T. S., & Courts, F. (2001). Assessing the effect of fluoride varnish on early enamel carious lesions in the primary dentition. *The Journal of the American Dental Association*, *132*, 1247–1253. <http://doi.org/10.14219/jada.archive.2001.0367>
- Babitsch, B., Gohl, D., & von Lengerke, T. (2012). Re-revisiting Andersen’s Behavioral Model of Health Services Use: a systematic review of studies from 1998-2011. *GMS Psycho-Social Medicine*, *9*(11), 1–15. <http://doi.org/10.3205/psm000089>
- Bader, J. D. (2009). Challenges in quality assessment of dental care. *Journal of the American Dental Association*, *140*(12), 1456–64. <http://doi.org/10.14219/JADA.ARCHIVE.2009.0084>
- Bailit, H. L., & Beazoglou, T. (2008). Financing Dental Care: Trends in Public and Private Expenditures for Dental Services. *Dental Clinics of North America*, *52*(2), 281–95, v. <http://doi.org/10.1016/j.cden.2007.11.004>
- Bailit, H. L., Beazoglou, T. J., DeVitto, J., McGowan, T., & Myne-Joslin, V. (2012). Impact of dental therapists on productivity and finances: I. Literature review. *Journal of Dental Education*, *76*(8), 1061–7. Retrieved from <http://www.ncbi.nlm.nih.gov/pubmed/22855592>
- Bair, A. E., Song, W. T., Chen, Y.-C., & Morris, B. A. (2010). The Impact of Inpatient Boarding on ED Efficiency: A Discrete-Event Simulation Study. *Journal of Medical Systems*, *34*(5), 919–929. <http://doi.org/10.1007/s10916-009-9307-4>
- Baker, S. R. (2009). Applying Andersen’s behavioural model to oral health: what are the contextual factors shaping perceived oral health outcomes? *Community Dentistry and Oral Epidemiology*, *37*(6), 485–494. <http://doi.org/10.1111/j.1600-0528.2009.00495.x>
- Balakrishnan, M., Simmonds, R. S., & Tagg, J. R. (2000). Dental caries is a preventable infectious disease. *Australian Dental Journal*, *45*(4), 235–245. <http://doi.org/10.1111/j.1834-7819.2000.tb00257.x>
- Banas, J. A. (2013). Delaying Streptococcus mutans Colonization in Children Leads to Reduced Caries Experience. *Journal of Evidence Based Dental Practice*, *13*(2), 67–69. <http://doi.org/10.1016/J.JEBDP.2013.04.007>
- Bar-Yam, Y. (2004). *Making Things Work: Solving complex problems in a complex world*. London: Knowledge Industry.
- Bar-Yam, Y. (2006). Improving the effectiveness of health care and public health: a multiscale complex systems analysis. *American Journal of Public Health*, *96*(3), 459–466. Retrieved from <http://ajph.aphapublications.org/doi/abs/10.2105/AJPH.2005.064444>
- Baril, C., Gascon, V., Miller, J., & Bounhol, C. (2017). The importance of considering resource’s tasks when modeling healthcare services with discrete-event simulation: an approach using work sampling method. *Journal of Simulation*, *11*(2), 103–114. <http://doi.org/10.1057/jos.2016.6>
- Bayer, S. (2014). Simulation modelling and resource allocation in complex services. *BMJ Qual Saf*, *23*, 353–355. <http://doi.org/10.1136/bmjqs-2013-002742>
- Beazoglou, T. J., Bailit, H. L., DeVitto, J., McGowan, T., & Myne-Joslin, V. (2012). Impact of dental therapists on

- productivity and finances: II. Federally Qualified Health Centers. *Journal of Dental Education*, 76(8), 1068–76. Retrieved from <http://www.ncbi.nlm.nih.gov/pubmed/22855593>
- Bellinger, G. (2004). Reinforcing Loop. Retrieved April 5, 2018, from <http://www.systems-thinking.org/theWay/sre/re.htm>
- Benjamin, P., Patki, M., & Mayer, R. (2006). Using Ontologies in Simulation Modeling. In L. F. Perrone, F. P. Wieland, D. M. N. J. Liu, B. G. Lawson, & R. M. Fujimoto (Eds.), *Proceedings of the 2006 Winter Simulation Conference* (pp. 1151–1159). Retrieved from <http://citeseerx.ist.psu.edu/viewdoc/download?doi=10.1.1.450.5611&rep=rep1&type=pdf>
- Berkowitz, R. J. (2003). Acquisition and transmission of mutans streptococci. *Journal of the California Dental Association*, 31(2), 135–138.
- Berkowitz, R. J. (2006). Mutans Streptococci: Acquisition and Transmission. *Pediatric Dentistry*, 28(2), 106–109. Retrieved from <http://www.ingentaconnect.com/search/download?pub=infobike://aapd/pd/2006/00000028/00000002/art00004&mimetype=application/pdf>
- Berkowitz, R. J., Jordan, H. V., & White, G. (1975). The early establishment of *Streptococcus mutans* in the mouths of infants. *Archives of Oral Biology*, 20(3), 171–4. Retrieved from <http://www.ncbi.nlm.nih.gov/pubmed/1054976>
- Berkowitz, R. J., Turner, J., & Green, P. (1980). Primary oral infection of infants with *Streptococcus mutans*. *Archives of Oral Biology*, 25(4), 221–224. Retrieved from <http://www.sciencedirect.com/science/article/pii/0003996980900266>
- Berkowitz, R. J., Turner, J., & Green, P. (1981). Maternal salivary levels of *Streptococcus mutans* and primary oral infection of infants. *Archives of Oral Biology*, 26(2), 147–149. [http://doi.org/10.1016/0003-9969\(81\)90086-8](http://doi.org/10.1016/0003-9969(81)90086-8)
- Berwick, D. M. (1989). Continuous Improvement as an Ideal in Health Care. *New England Journal of Medicine*, 320(1), 53–56. <http://doi.org/10.1056/NEJM198901053200110>
- Binder, T., Vox, A., Belyazid, S., & Haraldsson, O. (2004). Developing system dynamics models from causal loop diagrams. In *Proceedings of the 22nd International Conference of the System Dynamics Society, July 25–29*. Oxford, UK: System Dynamics Society. Retrieved from <https://pdfs.semanticscholar.org/cf00/b9084b05ba357bf0c5fa7a5b9cc1b5695015.pdf>
- Blackman, T., Hunter, D. J., Mckee, L., & Williams, G. (2006). PERFORMANCE ASSESSMENT AND WICKED PROBLEMS: THE CASE OF HEALTH INEQUALITIES. *Public Policy and Administration, August*. <http://doi.org/10.1177/095207670602100206>
- Blume L. (2015). Agent-Based Models for Policy Analysis. In Board on Population Health and Public HealthPractice, Institute of Medicine, R. Wallace, A. Geller, & V. Ogawa (Eds.), *Committee on the Assessment of Agent-Based Models to Inform Tobacco Product Regulation*. Washington (DC): National Academies Press (US). Retrieved from <https://www.ncbi.nlm.nih.gov/books/NBK305903/>
- Bonabeau, E. (2002). Agent-based modeling: methods and techniques for simulating human systems. *Proceedings of the National Academy of Sciences of the United States of America*, 99 Suppl 3(suppl 3), 7280–7. <http://doi.org/10.1073/pnas.082080899>
- Borchgrevink, A., Snyder, A., & Gehshan, S. (2008). The Effects of Medicaid Reimbursement Rates on Access to Dental Care. Retrieved from http://www.nashp.org/sites/default/files/CHCF_dental_rates.pdf
- Borrelli, B., Tooley, E. M., & Scott-Sheldon, L. A. J. (2015). Motivational Interviewing for Parent-child Health

- Interventions: A Systematic Review and Meta-Analysis. *Pediatric Dentistry*, 37(3), 254–265(12). Retrieved from <http://www.ingentaconnect.com/contentone/aapd/pd/2015/00000037/00000003/art00006>
- Borshchev, A. (2013). *The Big Book of Simulation Modeling - Multimethod Modeling with AnyLogic 6*. AnyLogic North America.
- Borshchev, A., & Filippov, A. (2004). From System Dynamics to Agent Based Modeling. *Simulation*, 66(11), 25–29. Retrieved from <http://www.econ.iastate.edu/tesfatsi/systemdyndiscreteeventabmcompared.borshchevfilippov04.pdf>
- Box, G. E. P. (1979). Robustness in the Strategy of Scientific Model Building. In *Robustness in Statistics* (pp. 201–236). Elsevier. <http://doi.org/10.1016/B978-0-12-438150-6.50018-2>
- Brailsford, S., & Schmidt, B. (2003). Towards incorporating human behaviour in models of health care systems: An approach using discrete event simulation. *European Journal of Operational Research*, 150(1), 19–31. [http://doi.org/10.1016/S0377-2217\(02\)00778-6](http://doi.org/10.1016/S0377-2217(02)00778-6)
- Bratthall, D., Hänsel-Petersson, G., & Sundberg, H. (1996). Reasons for the caries decline: what do the experts believe? *European Journal of Oral Sciences*, 104(4), 416–422. <http://doi.org/10.1111/j.1600-0722.1996.tb00104.x>
- Braun, P. A., Widmer-Racich, K., Sevick, C., Starzyk, E. J., Mauritsen, K., & Hambidge, S. J. (2017). Effectiveness on Early Childhood Caries of an Oral Health Promotion Program for Medical Providers. *Am J Public Health*, 107, 97–103. <http://doi.org/10.2105/AJPH.2017.303817>
- Brickhouse, T. H., Unkel, J. H., Kancitis, I., Best, A. M., & Davis, R. D. (2005). Infant oral health care: a survey of general dentists, pediatric dentists, and pediatricians in Virginia. *Pediatric Dentistry*, 30(2), 147–153. Retrieved from <http://docserver.ingentaconnect.com/deliver/connect/aapd/01641263/v30n2/s10.pdf?expires=1522614340&id=0000&titleid=75004753&checksum=3254A0CBA0C405E4B3F56892DC9B0480>
- Brinks, M. V., Dwight, R. H., Osgood, N. D., Sharavanakumar, G., Turbow, D. J., El-Gohary, M., ... Semenza, J. C. (2008). Health Risk of Bathing in Southern California Coastal Waters. *Archives of Environmental & Occupational Health*, 63(3), 123–135. <http://doi.org/10.3200/AEOH.63.3.123-135>
- Broadbent, J. M., Thomson, W. M., & Poulton, R. (2008). Trajectory Patterns of Dental Caries Experience in the Permanent Dentition to the Fourth Decade of Life. *Journal of Dental Research*, 87(1), 69–72. <http://doi.org/10.1177/154405910808700112>
- Brocklehurst, P., Mertz, E. A., Jerkovic-Cosic, K., Littlewood, A., & Tickle, M. (2014). Direct access to midlevel dental providers: An evidence synthesis. *Journal of Public Health Dentistry*, 74(4), 326–335. <http://doi.org/10.1111/jphd.12062>
- Brocklehurst, P. R., Ashley, J. R., & Tickle, M. (2011). Patient assessment in general dental practice - risk assessment or clinical monitoring? *British Dental Journal*, 210(8), 351–354. <http://doi.org/10.1038/sj.bdj.2011.284>
- Burgess, D. J., Fu, S. S., & Ryn, M. (2004). Why do providers contribute to disparities and what can be done about it? *Journal of General Internal Medicine*, 19(11), 1154–1159. <http://doi.org/10.1111/j.1525-1497.2004.30227.x>
- Capurro, D. A., Iafolla, T., Kingman, A., Chattopadhyay, A., & Garcia, I. (2015). Trends in income-related inequality in untreated caries among children in the United States: findings from NHANES I, NHANES III, and NHANES 1999-2004. *Community Dentistry and Oral Epidemiology*, 43(6), 500–510. <http://doi.org/10.1111/cdoe.12174>

- Caro, J. J., Möller, J., & Getsios, D. (2010). Discrete event simulation: The preferred technique for health economic evaluations? *Value in Health, 13*(8), 1056–1060. <http://doi.org/10.1111/j.1524-4733.2010.00775.x>
- Carol, L. (2016). Mom seeks answers after toddler dies in dental procedure. *2TODAY.Com*, p. April 1.
- Casamassimo, P. S., Lee, J. Y., Marazita, M. L., Milgrom, P., Chi, D. L., & Divaris, K. (2014). Improving Children's Oral Health: An Interdisciplinary Research Framework. *Journal of Dental Research, 93*(10), 938–942. <http://doi.org/10.1177/0022034514547273>
- Casamassimo, P. S., & Seale, N. S. (2014). Educating general dentists to care for U.S. children: how well are we doing and what can we do better? *Journal of the California Dental Association, 42*(11), 779–783. Retrieved from <http://search.ebscohost.com/login.aspx?direct=true&db=rzh&AN=107809282&site=ehost-live&scope=site>
- Casamassimo, P. S., Thikkurissy, S., Edelstein, B. L., & Maiorini, E. (2009). Beyond the dmft: The Human and Economic Cost of Early Childhood Caries. *The Journal of the American Dental Association, 140*(6), 650–657. <http://doi.org/10.14219/jada.archive.2009.0250>
- Castilho, A. R. F. de, Mialhe, F. L., Barbosa, T. de S., & Puppim-Rontani, R. M. (2013). Influence of family environment on children's oral health: a systematic review. *Jornal de Pediatria, 89*(2), 116–123. <http://doi.org/10.1016/J.JPED.2013.03.014>
- Caufield, P. W., Cutter, G. R., & Dasanayake, A. P. (1993). Initial acquisition of mutans streptococci by infants: evidence for a discrete window of infectivity. *Journal of Dental Research, 72*(1), 37–45. Retrieved from <http://jdr.sagepub.com/content/72/1/37.short>
- Center for Disease Control and Prevention (CDC). (2013). NHANES 2011-2012. Retrieved June 3, 2018, from <https://www.cdc.gov/nchs/nhanes/ContinuousNhanes/Default.aspx?BeginYear=2011>
- Center for Disease Control and Prevention (CDC). (2012). Water Fluoridation Statistics. Retrieved May 20, 2018, from <http://www.cdc.gov/fluoridation/statistics/2012stats.htm>
- Center for Disease Control and Prevention (CDC). (1999). Achievements in Public Health , 1900-1999 : Fluoridation of Drinking Water to Prevent Dental. *MMWR, 48*(41), 933–940. Retrieved from <https://www.cdc.gov/mmwr/preview/mmwrhtml/mm4841a1.htm>
- Centers for Medicare & Medicaid Services (CMS). (2016). *National health expenditures by type of service and source of funds: Calendar years 1960 to 2016*. Retrieved from <https://www.cms.gov/Research-Statistics-Data-and-Systems/Statistics-Trends-and-Reports/NationalHealthExpendData/NationalHealthAccountsHistorical.html>
- Centers for Medicare & Medicaid Services (CMS). (2017). *National Health Expenditures 2016 Highlights*. Retrieved from <https://www.cms.gov/Research-Statistics-Data-and-Systems/Statistics-Trends-and-Reports/NationalHealthExpendData/Downloads/highlights.pdf>
- Center for Scientific Information, ADA Science Institute. (2017). Caries Risk Assessment and Management. Retrieved May 9, 2018, from <https://www.ada.org/en/member-center/oral-health-topics/caries-risk-assessment-and-management>
- Chace, R. (1964). Reclassification of Crest Toothpaste; Council on Dental Therapeutics. *The Journal of the American Dental Association, 69*(2), 195–196. <http://doi.org/10.14219/JADA.ARCHIVE.1964.0247>
- Chaffee, B. W., Gansky, S. A., Weintraub, J. A., Featherstone, J. D. B., & Ramos-Gomez, F. J. (2014). Maternal Oral Bacterial Levels Predict Early Childhood Caries Development. *Journal of Dental Research, 93*(3), 238–244. <http://doi.org/10.1177/0022034513517713>

- Chalmers, N. I., Wislar, J. S., Boynes, S. G., Doherty, M., & Nový, B. B. (2017). Improving health in the United States: Oral health is key to overall health. *The Journal of the American Dental Association*. <http://doi.org/10.1016/j.adaj.2017.04.031>
- Cheng, J., Chaffee, B. W., Cheng, N. F., Gansky, S. A., & Featherstone, J. D. B. (2015). Understanding Treatment Effect Mechanisms of the CAMBRA Randomized Trial in Reducing Caries Increment. *Journal of Dental Research*, *94*(1), 44–51. <http://doi.org/10.1177/0022034514555365>
- Chestnutt, I. G., Schäfer, F., Jacobson, A. P. M., & Stephen, K. W. (1998). The influence of toothbrushing frequency and post-brushing rinsing on caries experience in a caries clinical trial. *Community Dentistry and Oral Epidemiology*, *26*(6), 406–411. <http://doi.org/10.1111/j.1600-0528.1998.tb01979.x>
- Choon, O. H., Dali, Z., Beng, P. T., & Magdalene, C. P. Y. (2014). Uncovering effective process improvement strategies in an emergency department using discrete event simulation. *Health Systems*, *3*(2), 93–104. <http://doi.org/10.1057/hs.2014.2>
- Christensen, G. J. (2001). The credibility of dentists. *Journal of the American Dental Association (1939)*, *132*(8), 1163–5. <http://doi.org/10.14219/JADA.ARCHIVE.2001.0344>
- Christy. (n.d.). Tip-Don't Let Kids Brush Their Teeth Solo Until They Can Tie Their Shoes. Retrieved May 4, 2018, from <http://harvardhomemaker.com/kids-brush-their-own-teeth-when-they-can-tie-shoes/>
- Churchill, S. S., Williams, B. J., & Villareale, N. L. (2007). Characteristics of Publicly Insured Children with High Dental Expenses. *Journal of Public Health Dentistry*, *67*(4), 199–207. <http://doi.org/10.1111/j.1752-7325.2007.00046.x>
- Clayton, B. (2016). Personality Types of Dentists. Retrieved April 24, 2018, from <http://digitalenamel.com/personality-types-of-dentists/>
- CMS-416. (2017). Retrieved from <https://www.cms.gov/Regulations-and-Guidance/Legislation/PaperworkReductionActof1995/PRA-Listing-Items/CMS-416.html>
- CMS. (n.d.). Early and Periodic Screening, Diagnostic, and Treatment. Retrieved June 3, 2018, from <https://www.medicaid.gov/medicaid/benefits/epsdt/index.html>
- CMS. (2004). *Guide to Children's Dental Care in Medicaid*. Retrieved from <https://www.medicaid.gov/medicaid/benefits/downloads/child-dental-guide.pdf>
- Cohen, L. A., Bonito, A. J., Akin, D. R., Manski, R. J., Macek, M. D., Edwards, R. R., & Cornelius, L. J. (2008). Toothache pain: a comparison of visits to physicians, emergency departments and dentists. *The Journal of the American Dental Association*, *139*(9), 1205–1216. Retrieved from <http://www.sciencedirect.com/science/article/pii/S0002817714619292>
- Compton, R. (2015). Business Barriers and Opportunities for Transforming to Preventive Care to Treat Early Childhood Caries. *Pediatric Dentistry*, *37*(3 (May/June)), 288–293. Retrieved from <http://www.ingentaconnect.com/content/aapd/pd/2015/00000037/00000003/art00010>
- Conrad, D. A., Lee, R. S.-Y., Milgrom, P., & Huebner, C. E. (2010). Estimating determinants of dentist productivity: new evidence. *Journal of Public Health Dentistry*, *70*(4), 262–268. <http://doi.org/10.1111/j.1752-7325.2010.00180.x>
- Crall, J. J. (2005). Development and Integration of Oral Health Services for Preschool-age Children. *Pediatric Dentistry*, *27*(4), 323–330. Retrieved from <http://www.ingentaconnect.com/search/download?pub=infobike://aapd/pd/2005/00000027/00000004/art00010&mimetype=application/pdf>

- Crall, J. J., & Forrest, C. B. (2018). A Life Course Health Development Perspective on Oral Health. In N. Halfon, C. B. Forrest, R. M. Lerner, & E. M. Faustman (Eds.), *Handbook of Life Course Health Development* (pp. 299–320). Cham: Springer International Publishing. http://doi.org/10.1007/978-3-319-47143-3_13
- Crall, J. J., Pourat, N., Inkelas, M., Lampron, C., & Scoville, R. (2016). Improving The Oral Health Care Capacity Of Federally Qualified Health Centers. *Health Affairs*, 35(12), 2216–2223. <http://doi.org/10.1377/hlthaff.2016.0880>
- Crall, J. J., Szlyk, C. I., & Schneider, D. A. (1999). Pediatric Oral Health Performance Measurement: Current Capabilities and Future Directions. *Journal of Public Health Dentistry*, 59(3), 136–141. <http://doi.org/10.1111/j.1752-7325.1999.tb03262.x>
- Creeth, J. E., Gallagher, A., Sowinski, J., Bowman, J., Barrett, K., Lowe, S., ... Bosma, M. L. (2009). The effect of brushing time and dentifrice on dental plaque removal in vivo. *Journal of Dental Hygiene : JDH / American Dental Hygienists' Association*, 83(3), 111–116.
- Cury, J. A., Do Amaral, R. C., Tenuta, L. M. A., Del Bel Cury, A. A., & Tabchoury, C. P. M. (2010). Low-fluoride toothpaste and deciduous enamel demineralization under biofilm accumulation and sucrose exposure. *European Journal of Oral Sciences*, 118(4), 370–375. <http://doi.org/10.1111/j.1600-0722.2010.00745.x>
- D'Anna, L. H., Hansen, M., Mull, B., Canjura, C., Lee, E., & Sumstine, S. (2018). Social Discrimination and Health Care: A Multidimensional Framework of Experiences among a Low-Income Multiethnic Sample. *Social Work in Public Health*, 33(3), 187–201. <http://doi.org/10.1080/19371918.2018.1434584>
- Dagkakis, G., & Heavey, C. (2016). A review of open source discrete event simulation software for operations research. *Journal of Simulation*, 10(3), 193–206. <http://doi.org/10.1057/jos.2015.9>
- Davies, R. M., Davies, G. M., Ellwood, R. P., & Kay, E. J. (2003). Prevention. Part 4: Toothbrushing: What advice should be given to patients? *British Dental Journal*, 195(3), 135–141. <http://doi.org/10.1038/sj.bdj.4810396>
- Davis, E. E., Deinard, A. S., & Maïga, E. W. H. (2010). Doctor, my tooth hurts: the costs of incomplete dental care in the emergency room. *Journal of Public Health Dentistry*, 70(3), 205–210. <http://doi.org/10.1111/j.1752-7325.2010.00166.x>
- Dawes, C. (2003). What Is the Critical pH and Why Does a Tooth Dissolve in Acid? *J Can Dent Assoc*, 69(11), 722–724. Retrieved from http://www.cda-adc.ca/jcda/vol-69/issue-11/vol69_issue11.pdf#page=22
- Day, T. E., Ravi, N., Xian, H., & Brugh, A. (2013). An Agent-Based Modeling Template for a Cohort of Veterans with Diabetic Retinopathy. *PLoS ONE*, 8(6), e66812. <http://doi.org/10.1371/journal.pone.0066812>
- Day, T. E., Ravi, N., Xian, H., & Brugh, A. (2014). Sensitivity of diabetic retinopathy associated vision loss to screening interval in an agent-based/discrete event simulation model. *Computers in Biology and Medicine*, 47(1), 7–12. <http://doi.org/10.1016/j.combiomed.2014.01.007>
- Debarys, N. (2017). *Understanding interactions in complex systems : toward a science of interaction*. (S. C. Nicolas Debarys, Cem Ertur, François Nemo, G. P. Déborah Nourrit-Lucas, & Christel Vrain, Eds.).
- Dental Quality Alliance. (2017). *DQA Measure Specifications: Administrative Claims-Based Measures* (No. DQA Measure CRD-CH-A). Retrieved from https://www.ada.org/~media/ADA/Science_and_Research/Files/DQA_Risk_Documentation_in_Children.pdf?la=en
- Dhar, V. (2016). Evidence-based dentistry: An overview. *Contemporary Clinical Dentistry*, 7(3), 293–4. <http://doi.org/10.4103/0976-237X.188539>
- Dias, K. R., Andrade, C. B. de, Wait, T. T. de A., Chamon, R. C., dos Santos, K. R. N., Soviero, V. M., ... Fonseca-

- Gonçalves, A. (2017). Influence of the microbiological component of Cariogram® for evaluating the risk of caries in children. *Acta Odontologica Scandinavica*, 75(6), 446–452. <http://doi.org/10.1080/00016357.2017.1334960>
- Diez Roux, A. V. (2011). Complex Systems Thinking and Current Impasses in Health Disparities Research. *American Journal of Public Health*, 101(9), 1627–1634. <http://doi.org/10.2105/AJPH.2011.300149>
- Diringer, J., Phipps, K., & Carsel, B. (2013). *CRITICAL TRENDS AFFECTING THE FUTURE OF DENTISTRY: Assessing the Shifting Landscape*. San Luis Obispo, CA. Retrieved from http://www.ada.org/~media/ADA/Member_Center/Files/Escan2013_Diringer_Full.ashx
- Dolan, T. A. (2015). Preparing the oral health workforce to effectively address public health challenges. *Journal of Public Health Dentistry*, 72, 51–53. Retrieved from <https://onlinelibrary.wiley.com/doi/pdf/10.1111/jphd.12132>
- dos Santos Noronha, M., Andrade Romão, D., Aparecido Cury, J., & Pereira Machado Tabchoury, C. (2016). Effect of fluoride concentration on reduction of enamel demineralization according to the cariogenic challenge. *Brazilian Dental Journal*, 27(4), 393–398. <http://doi.org/10.1590/0103-6440201600831>
- Douglass, J. M., Tinanoff, N., Tang, J. M. W., & Altman, D. S. (2001). Dental caries patterns and oral health behaviors in Arizona infants and toddlers. *Community Dentistry and Oral Epidemiology*, 29(1), 14–22. <http://doi.org/10.1034/j.1600-0528.2001.00004.x>
- Drury, T. F., Horowitz, A. M., Ismail, A. I., Maertens, M. P., Rozier, R. G., & Selwitz, R. H. (1999a). Diagnosing and Reporting Early Childhood Caries for Research Purposes: A Report of a Workshop Sponsored by the National Institute of Dental and Craniofacial Research, the Health Resources and Services Administration, and the Health Care Financing Administration. *Journal of Public Health Dentistry*, 59(3), 192–197. <http://doi.org/10.1111/j.1752-7325.1999.tb03268.x>
- Drury, T. F., Horowitz, A. M., Ismail, A. I., Maertens, M. P., Rozier, R. G., & Selwitz, R. H. (1999b). Diagnosing and reporting early childhood caries for research purposes. A report of a workshop sponsored by the National Institute of Dental and Craniofacial Research, the Health Resources and Services Administration, and the Health Care Financing Administ. *Journal of Public Health Dentistry*, 59(3), 192–7. <http://doi.org/10.1111/j.1752-7325.1999.tb03268.x>
- Dufour, Y., & Steane, P. (2013). Implementing Disruptive Innovation : A Wicked Problem for Health Care Managers? *Management & Avenir Santé*, N° 1(1), 33. <http://doi.org/10.3917/mavs.001.0033>
- Duhigg, C. (2012). *The power of habit : why we do what we do in life and business*. Random House. Retrieved from https://books.google.com/books?id=O1MInVXd_a0C&dq=power+of+habit+charles+duhigg&lr=&source=gbs_navlinks_s
- Duijster, D., Verrips, G. H. W., & van Loveren, C. (2014). The role of family functioning in childhood dental caries. *Community Dentistry and Oral Epidemiology*, 42(3), 193–205. <http://doi.org/10.1111/cdoe.12079>
- Dukes, N. (2014). Are you CAMBRA ready? - Dental Economics. Retrieved April 23, 2018, from <https://www.dentaleconomics.com/articles/print/volume-104/issue-4/features/are-you-cambra-ready.html>
- Dyck, R., Osgood, N., Gao, A., & Stang, M. R. (2012). The Epidemiology of Diabetes Mellitus among First Nations and non-First Nations Children in Saskatchewan. *Canadian Journal of Diabetes*, 36(1), 19–24. <http://doi.org/10.1016/j.jcjd.2011.11.001>
- Dye, B. A., Li, X., Beltrán-Aguilar, E. D., & others. (2012). *Selected oral health indicators in the United States, 2005-2008. NCHS Data Brief*. Retrieved from http://www.aapd.org/assets/1/7/May_2012_-_2005-2006_oral_health_indicators.pdf

- Dye, B. A., Tan, S., Smith, V., Lewis, B., Barker, L., Thornton-Evans, G., ... Center, R. (2007). *Trends in oral health status: United States, 1988-1994 and 1999-2004. ital and Health Statistics* (Vol. 11). Retrieved from https://www.cdc.gov/nchs/data/series/sr_11/sr11_248.pdf
- Dye, B. A., Thornton-Evans, G., Li, X., & Iafolla, T. J. (2015a). Dental Caries and Sealant Prevalence in Children and Adolescents in the United States, 2011 – 2012. *NCHS Data Brief*, (191), 1–8. Retrieved from <http://www.cdc.gov/nchs/data/databriefs/db191.htm>
- Dye, B. A., Thornton-Evans, G., Li, X., & Iafolla, T. J. (2015b). Dental Caries and Tooth Loss in Adults in the United States, 2011–2012. *NCHS Data Brief*, (197), 1–8. <http://doi.org/10.1080/713604647>
- Dye, B. A., Vargas, C. M., Lee, J. Y., Magder, L., & Tinanoff, N. (2011). Assessing the relationship between children’s oral health status and that of their mothers. *The Journal of the American Dental Association*, *142*(2), 173–183. Retrieved from <http://www.sciencedirect.com/science/article/pii/S0002817714614987>
- Dye BA, Li X, Thornton-Evans G. Oral health disparities as determined by selected Healthy People 2020 oral health objectives for the United States, 2009–2010. NCHS - Google Scholar. (n.d.). Retrieved May 22, 2015, from https://scholar.google.com/scholar?hl=en&q=Dye+BA%2C+Li+X%2C+Thornton-Evans+G.+Oral+health+disparities+as+determined++by+selected+Healthy+People+2020+oral+health+objectives+for+the+United+States%2C++2009–2010.+NCHS+&btnG=&as_sdt=1%2C5&as_sdtp=
- Edelstein, B. L. (2002). Disparities in Oral Health and Access to Care: Findings of National Surveys. *Ambulatory Pediatrics*, *2*(2).
- Edelstein, B. L., & Chinn, C. H. (2009). Update on Disparities in Oral Health and Access to Dental Care for America’s Children. *Academic Pediatrics*, *9*(6), 415–419. <http://doi.org/10.1016/j.acap.2009.09.010>
- Edelstein, B. L., Hirsch, G. B., Frosh, M., & Kumar, J. (2015). Reducing early childhood caries in a Medicaid population - A System Model Analysis. *The Journal of the American Dental Association*, *146*(4), 224–232. <http://doi.org/10.1016/j.adaj.2014.12.024>
- Eklund, S. a, Pittman, J. L., & Clark, S. J. (2003). Michigan Medicaid’s Healthy Kids Dental program: an assessment of the first 12 months. *Journal of the American Dental Association* (1939), *134*(11), 1509–1515.
- El-Sayed, A. M., & Galea, S. (Eds.). (2017). *System Science and Population Health*. Oxford University Press, New York.
- Elkhuizen, S. G., Das, S. F., Bakker, J. M., & Hontelez, M. (2007). Using computer simulation to reduce access time for outpatient departments. *Qual Saf Health Care*, *16*, 382–386. <http://doi.org/10.1136/qshc.2006.021568>
- Emanuelsson, I. R., Li, Y., & Bratthall, D. (1998). Genotyping shows different strains of mutans streptococci between father and child and within parental pairs in Swedish families. *Oral Microbiology and Immunology*, *13*(5), 271–277. <http://doi.org/10.1111/j.1399-302X.1998.tb00707.x>
- Epstein, J. M. (2008, October). Why Model? Retrieved May 24, 2015, from <http://jasss.soc.surrey.ac.uk/11/4/12.html>
- Ericson, D., Kidd, E., McComb, D., Mjor, I., & Noack, M. J. (2003). Minimally Invasive Dentistry - Concepts and Techniques in Cariology. *Oral Health & Preventive Dentistry*, *1*(1), 59–72. Retrieved from https://www.researchgate.net/profile/Michael_Noack2/publication/8087159_Minimally_Invasive_Dentistry_-_concepts_and_techniques_in_cariology/links/569d034208ae03384dd04031/Minimally-Invasive-Dentistry-concepts-and-techniques-in-cariology.pdf
- EzEldeen, M., Gizani, S., & Declerck, D. (2015). Long-term outcome of oral health in patients with early childhood caries treated under general anaesthesia. *European Archives of Paediatric Dentistry*, *16*(4), 333–340.

<http://doi.org/10.1007/s40368-014-0167-3>

- Featherstone, J. D. B. (2000). The Science and Practice of Caries Prevention. *The Journal of the American Dental Association*, 131(7), 887–899. <http://doi.org/10.14219/jada.archive.2000.0307>
- Featherstone, J. D. B. (2003). Cariology in the New World Order: Moving from Restoration Toward Prevention. *Journal of the California Dental Association*, 31(2), 123–124.
- Featherstone, J. D. B. (2006). Caries prevention and reversal based on the caries balance. *Pediatric Dentistry*, 28(2), 128–132. Retrieved from <http://www.ingentaconnect.com/search/download?pub=infobike://aapd/pd/2006/00000028/00000002/art00007&mimetype=application/pdf>
- Featherstone, J. D. B., & Chaffee, B. W. (2018). The Evidence for Caries Management by Risk Assessment (CAMBRA®). *Advances in Dental Research*, 29(1), 9–14. <http://doi.org/10.1177/0022034517736500>
- Featherstone, J. D. B., White, J. M., Hoover, C. I., Rapozo-Hilo, M., Weintraub, J. A., Wilson, R. S., ... Gansky, S. A. (2012). A Randomized Clinical Trial of Anticaries Therapies Targeted according to Risk Assessment (Caries Management by Risk Assessment). *Caries Research*, 46(2), 118–129. <http://doi.org/10.1159/000337241>
- Fejerskov, O., Nyvad, B., & Kidd, E. A. M. (2015). *Dental caries : the disease and its clinical management*. (O. Fejerskov, B. Nyvad, & E. A. M. Kidd, Eds.) (3rd ed.). Oxford: Wiley Balckwell. Retrieved from <https://www.wiley.com/en-us/Dental+Caries%3A+The+Disease+and+its+Clinical+Management%2C+3rd+Edition-p-9781118935828>
- Ferreira-Nóbilo, N. de P., Sousa, M. da L. R. de, Cury, J. A., Ferreira-Nóbilo, N. de P., Sousa, M. da L. R. de, & Cury, J. A. (2014). Conceptualization of Dental Caries by Undergraduate Dental Students from the First to the Last Year. *Brazilian Dental Journal*, 25(1), 59–52. <http://doi.org/10.1590/0103-6440201302359>
- Finlayson, T. L., Gupta, A., & Ramos-Gomez, F. J. (2017). Prenatal Maternal Factors, Intergenerational Transmission of Disease, and Child Oral Health Outcomes. *Dental Clinics of North America*, 61(3), 483–518. <http://doi.org/10.1016/J.CDEN.2017.02.001>
- Finlayson, T. L., Siefert, K., Ismail, A. I., & Sohn, W. (2007a). Maternal self-efficacy and 1-5-year-old children's brushing habits. *Community Dentistry and Oral Epidemiology*, 35(4), 272–281. <http://doi.org/10.1111/j.1600-0528.2007.00313.x>
- Finlayson, T. L., Siefert, K., Ismail, A. I., & Sohn, W. (2007b). Psychosocial factors and early childhood caries among low-income African-American children in Detroit. *Community Dentistry and Oral Epidemiology*, 35(6), 439–448. <http://doi.org/10.1111/j.1600-0528.2006.00352.x>
- Fisher-Owens, S. A. (2014). Broadening Perspectives on Pediatric Oral Health Care Provision: Social Determinants of Health and Behavioral Management. *Pediatric Dentistry*, 36(2), 115–120. Retrieved from <http://www.ingentaconnect.com/search/download?pub=infobike://aapd/pd/2014/00000036/00000002/art00004&mimetype=application/pdf>
- Fisher-Owens, S. A., Gansky, S. A., Platt, L. J., Weintraub, J. A., Soobader, M.-J., Bramlett, M. D., & Newacheck, P. W. (2007). Influences on Children's Oral Health: A Conceptual Model. *PEDIATRICS*, 120(3), e510–e520. <http://doi.org/10.1542/peds.2006-3084>
- Fone, D., Hollinghurst, S., Temple, M., Round, A., Lester, N., Weightman, A., ... Palmer, S. (2003). Systematic review of the use and value of computer simulation modelling in population health and health care delivery. *Journal of Public Health Medicine*, 25(4), 325–335. <http://doi.org/10.1093/pubmed/fgd075>

- Fried, J. (2013). Interprofessional collaboration: if not now, when? *Journal of Dental Hygiene : JDH*, 87 Suppl 1(suppl 1), 41–3. Retrieved from <http://www.ncbi.nlm.nih.gov/pubmed/24046341>
- Fryer, A. (2005). Dental problems hurting soldiers' readiness. *The Seattle Times*.
- Gao, A., Osgood, N. D., An, W., Dyck, R. F., Gao, A., Osgood, N. D., ... Dyck, R. F. (2014). A tripartite hybrid model architecture for investigating health and cost impacts and intervention tradeoffs for diabetic end-stage renal disease. *Proceedings of the 2014 Winter Simulation Conference*. IEEE Press. Retrieved from <https://dl.acm.org/citation.cfm?id=2694061>
- Gao, A., Osgood, N. D., Jiang, Y., & Dyck, R. F. (2017). Projecting prevalence, costs and evaluating simulated interventions for diabetic end stage renal disease in a Canadian population of aboriginal and non-aboriginal people: an agent based approach. *BMC Nephrology*, 18(1), 283. <http://doi.org/10.1186/s12882-017-0699-y>
- Gao, S. S., Zhang, S., Mei, M. L., Lo, E. C.-M., & Chu, C.-H. (2016). Caries remineralisation and arresting effect in children by professionally applied fluoride treatment - a systematic review. *BMC Oral Health*, 16(1). <http://doi.org/10.1186/s12903-016-0171-6>
- Garcia, R. I., Inge, R. E., Niessen, L., & Depaola, D. P. (2010). Envisioning success: The future of the oral health care delivery system in the United States. *Journal of Public Health Dentistry*. <http://doi.org/10.1111/j.1752-7325.2010.00185.x>
- Gardner, B. (2015). A review and analysis of the use of 'habit' in understanding, predicting and influencing health-related behaviour. *Health Psychology Review*, 9(3), 277–295. <http://doi.org/10.1080/17437199.2013.876238>
- Garg, N., Anandakrishna, L., & Chandra, P. (2012). Is there an Association between Oral Health Status and School Performance? A Preliminary Study. *Int J Clin Pediatr Dent*, 5(2), 132–135. <http://doi.org/10.5005/jp-journals-10005-1150>
- Garg, S., Rubin, T., Jasek, J., Weinstein, J., Helburn, L., & Kaye, K. (2013). How willing are dentists to treat young children? A survey of dentists affiliated with Medicaid managed care in New York City, 2010. *The Journal of the American Dental Association*, 144(4), 416–425. <http://doi.org/10.14219/JADA.ARCHIVE.2013.0135>
- Gawande, A. (2012). Something Wicked This Way Comes | The New Yorker. *The New Yorker*, 1–5. Retrieved from <https://www.newyorker.com/news/daily-comment/something-wicked-this-way-comes>
- Gerberding, J. L. (2005). Protecting Health—The New Research Imperative. *JAMA*, 294(11), 1403. <http://doi.org/10.1001/jama.294.11.1403>
- Gift, H. C. (1997). A Look at Oral Health within the Context of Diverse Populations: Foreword. *Advances in Dental Research*, 11(2), 200–202. <http://doi.org/10.1177/08959374970110020101>
- Gilbert, G. H., Gordan, V. V., Korelitz, J. J., Fellows, J. L., Meyerowitz, C., Oates, T. W., ... National Dental PBRN Collaborative Group. (2015). Provision of specific dental procedures by general dentists in the National Dental Practice-Based Research Network: questionnaire findings. *BMC Oral Health*, 15(1), 11. <http://doi.org/10.1186/1472-6831-15-11>
- Godin, G., Bélanger-Gravel, A., Eccles, M., & Grimshaw, J. (2008). Healthcare professionals' intentions and behaviours: A systematic review of studies based on social cognitive theories. *Implementation Science*, 3(1), 36. <http://doi.org/10.1186/1748-5908-3-36>
- Gonçalves, J. D. A., Moreira, E. A. M., Rauen, M. S., Rossi, A., & Borgatto, A. F. (2016). Associations Between Caries Experience, Nutritional Status, Oral Hygiene, and Diet in a Multigenerational Cohort. *Pediatric Dentistry*, 38(3).

- Grembowski, D., Andersen, R. M., & Chen, M. -s. M. (1989). A Public Health Model of the Dental Care Process. *Medical Care Review*, *46*(4), 439–496. <http://doi.org/10.1177/107755878904600405>
- Grembowski, D., Milgrom, P., & Fiset, L. (1988). Factors Influencing Dental Decision Making. *Journal of Public Health Dentistry*, *48*(3), 159–167. <http://doi.org/10.1111/j.1752-7325.1988.tb03186.x>
- Grytten, J. (2017). Payment systems and incentives in dentistry. *Community Dentistry and Oral Epidemiology*, *45*(1), 1–11. <http://doi.org/10.1111/cdoe.12267>
- Guay, A. H., Wall, T. P., Petersen, B. C., & Lazar, V. F. (2012). Evolving Trends in Size and Structure of Group Dental Practices in the United States. *Journal of Dental Education* ■, *76*(8). Retrieved from <http://www.jdentaled.org/content/76/8/1036.full.pdf>
- Gurses, A. P., Marsteller, J. A., Ozok, A. A., Xiao, Y., Owens, S., & Pronovost, P. J. (2010). Using an interdisciplinary approach to identify factors that affect clinicians' compliance with evidence-based guidelines. *Critical Care Medicine*, *38*(8), S282–S291. <http://doi.org/10.1097/CCM.0b013e3181e69e02>
- Gustafsson, B. E., Quensel, C.-E., Lanke, L. S., Lundqvist, C., Grahnén, H., Bonow, B. E., & Krasse, B. (1953). The Effect of Different Levels of Carbohydrate Intake on Caries Activity in 436 Individuals Observed for Five Years. *Acta Odontologica Scandinavica*, *11*(3–4), 232–364. <http://doi.org/10.3109/00016355308993925>
- Gutacker, N., Harris, A., Brennan, D., & Hollingsworth, B. (2015). The determinants of dentists' productivity and the measurement of output. *Social Science & Medicine*, *124*, 76–84. <http://doi.org/10.1016/j.socscimed.2014.11.020>
- Guzmán-Armstrong, S., Chalmers, J., & Warren, J. J. (2010). White spot lesions: Prevention and treatment. *American Journal of Orthodontics and Dentofacial Orthopedics*, *138*, 690–696. <http://doi.org/10.1016/j.ajodo.2010.07.007>
- Haber, J. (2014). BUILDING A CULTURE OF COLLABORATION: INTERPROFESSIONAL EDUCATION AND PRACTICE. *JADE, Spring*. Retrieved from https://dental.nyu.edu/content/dam/nyudental/documents/jade/vol2/jade_v2_haber.pdf
- Hameş-Kocabaş, E. E., Uçar, F., Kocataş Ersin, N., Uzel, A., & Alpöz, A. R. (2008). Colonization and vertical transmission of *Streptococcus mutans* in Turkish children. *Microbiological Research*, *163*(2), 168–172. <http://doi.org/10.1016/J.MICRES.2006.03.016>
- Hammond, R. A. (2015). Appendix A: Considerations and best practices in agent-based modeling to inform policy. In Committee on the Assessment of Agent-Based Models to Inform Tobacco Product Regulation; Board on Population Health and Public Health Practice; Institute of Medicine, Wallace R, Geller A, & Ogawa VA (Eds.), *Assessing the Use of Agent-Based Models for Tobacco Regulation* (pp. 1–28). Washington, DC: National Academies Press (US). Retrieved from <https://www.ncbi.nlm.nih.gov/books/NBK305917/>
- Hänsel Petersson, G., Åkerman, S., Isberg, P.-E., & Ericson, D. (2017). Comparison of risk assessment based on clinical judgement and Cariogram in addition to patient perceived treatment need. *BMC Oral Health*, *17*(1), 13. <http://doi.org/10.1186/s12903-016-0238-4>
- Harris, R. (1963). Biology of the Children of Hopewood House, Bowral, Australia. 4. Observations on Dental-Caries Experience Extending over Five Years (1957-61). *Journal of Dental Research*, November-December, 1387–1399. Retrieved from <http://journals.sagepub.com/doi/pdf/10.1177/00220345630420061601>
- Harris, R., Nicoll, A. D., Adair, P. M., Pine, C. M., & Harris, R. V. (2004). Risk factors for dental caries in young children: a systematic review of the literature. *Community Dental Health*, *21*, 71–85. Retrieved from http://www.who.int/oral_health/media/en/orh_cdh_0304_05_risk_factors.pdf

- Harris, R. V., Pennington, A., & Whitehead, M. (2017). Preventive dental visiting: a critical interpretive synthesis of theory explaining how inequalities arise. *Community Dentistry and Oral Epidemiology*, 45(2), 120–134. <http://doi.org/10.1111/cdoe.12268>
- Hart, J. T. (1971). The Inverse Care Law. *The Lancet*, 1, 405–412. Retrieved from http://ac.els-cdn.com/S014067367192410X/1-s2.0-S014067367192410X-main.pdf?_tid=bfac6c20-e753-11e6-98b4-00000aacb361&acdnat=1485825936_8bf9f51685f1b00dbb91a1b70955e4e5
- Hashemian, M., Stanley, K., & Osgood, N. D. (2012). Leveraging H1N1 infection transmission modeling with proximity sensor microdata. *BMC Medical Informatics and Decision Making*, 12(1), 35. <http://doi.org/10.1186/1472-6947-12-35>
- Head, D. A., Marsh, P. D., & Devine, D. A. (2014). Non-Lethal Control of the Cariogenic Potential of an Agent-Based Model for Dental Plaque. *PLoS ONE*, 9(8), e105012. <http://doi.org/10.1371/journal.pone.0105012>
- Heirich, M. (1998). *Rethinking Health Care - Innovation and Change in America*. Boulder, CO: Westview Press.
- Hibbard, J. H., Greene, J., Becker, E. R., Roblin, D., Painter, M. W., Perez, D. J., ... Tusler, M. (2008). Racial/Ethnic Disparities And Consumer Activation In Health. *Health Affairs*, 27(5), 1442–1453. <http://doi.org/10.1377/hlthaff.27.5.1442>
- Hirsch, G. B., Edelstein, B. B. L., Frosh, M., & Anselmo, T. (2012). A Simulation Model for Designing Effective Interventions in Early Childhood Caries. *Preventing Chronic Disease*, 9(1), 1–9. <http://doi.org/10.5888/pcd9.110219>
- Hirsch, G. B., Homer, J. B., McDonnell, G., & Milstein, B. (2005). Achieving Health Care Reform in the United States: Toward a Whole-System Understanding. *Proceedings of the 23rd International Conference of the System Dynamics Society*, 81. Retrieved from http://s3.amazonaws.com/academia.edu.documents/43374720/Achieving_health_care_reform_in_the_Unit20160304-20854-1ot8e3p.pdf?AWSAccessKeyId=AKIAIWOWYYGZ2Y53UL3A&Expires=1490824745&Signature=MV2dfnOb%2B6jje5VkhfJYaNui2LM%3D&response-content-disposition=inlin
- Hoekstra, K. (2016). Arizona lawmakers ponder dental therapy to address shortage | Alaska | watchdog.org. Retrieved April 1, 2018, from https://www.watchdog.org/alaska/arizona-lawmakers-ponder-dental-therapy-to-address-shortage/article_6159daba-7789-5e7c-82c9-e2d5644556ff.html
- Homer, J. B., & Hirsch, G. B. (2006). System Dynamics Modeling for Public Health: Background and Opportunities. *American Journal of Public Health* *Am J Public Health*, 96(3), 452–458. <http://doi.org/10.2105/AJPH.2005>
- Hovmand, P. S. (2014). *Community Based System Dynamics*. New York: Springer. Retrieved from <https://link.springer.com/content/pdf/10.1007%2F978-1-4614-8763-0.pdf>
- Hummel J, Phillips KE, Holt B, H. C. (2015). Oral Health: An Essential Component of Primary Care. Retrieved from <http://www.safetynetmedicalhome.org/sites/default/files/White-Paper-Oral-Health-Primary-Care.pdf>
- Hurlbutt, M., & Young, D. A. (2014). A Best Practices Approach to Caries Management. *Journal of Evidence Based Dental Practice*, 14 Suppl, 77–86. <http://doi.org/10.1016/j.jebdp.2014.03.006>
- Hussey, P., Bankowitz, R., Dinneen, M., Kelleher, D., Matsuoka, K., Mccannon, J., ... Saunders, R. (2013). From Pilots to Practice: Speeding the Movement of Successful Pilots to Effective Practice. Retrieved from <http://nam.edu/wp-content/uploads/2015/06/Pilots.pdf>
- Iben, P., Kanellis, M. J., & Warren, J. (2000). Appointment-keeping behavior of Medicaid-enrolled pediatric dental

- patients in eastern Iowa. *Pediatric Dentistry*, 22(6), 325–329.
- Iheozor-Ejiogor, Z., Worthington, H. V., Walsh, T., O'Malley, L., Clarkson, J. E., Macey, R., ... Glenny, A. M. (2015). Water fluoridation for the prevention of dental caries. *The Cochrane Database of Systematic Reviews*, 6. <http://doi.org/10.1002/14651858.CD010856.pub2>
- Institute of Medicine (IOM). (2011). *Advancing Oral Health in America*. Washington, DC. Retrieved from <http://www.hrsa.gov/publichealth/clinical/oralhealth/advancingoralhealth.pdf>
- Institute of Medicine (IOM), & Committee on Understanding and Eliminating Racial and Ethnic Disparities in HealthCare. (2003). *Unequal Treatment: Confronting Racial and Ethnic Disparities in Health Care*. (Brian D. Smedley, Adrienne Y. Stith, and Alan R. Nelson, Ed.). Washington, D.C.: The National Academies Press.
- Institute of Medicine and National Research Council. (2011). *Improving Access to Oral Health Care for Vulnerable and Underserved Populations*. Washington, D.C.: National Academies Press. <http://doi.org/10.17226/13116>
- Institute of Medicine, & Harris, T. A. (Rapporteur. (2009). *The U.S. Oral Health Workforce in the Coming Decade: Workshop Summary - Institute of Medicine, Board on Health Care Services*. National Academy of Sciences. Retrieved from <https://books.google.com/books?hl=en&lr=&id=-H9jAgAAQBAJ&oi=fnd&pg=PP1&dq=alternate+dental+workforce+models&ots=JzBJFYAUHo&sig=16wqBRIQ4RA9y-YIZ68vWNGtsY0#v=onepage&q=alternate+dental+workforce+models&f=false>
- Ismail, A. I., Bader, J. D., ADA Council on Scientific Affairs and Division of Science, & Journal of the American Dental Association. (2004). Evidence-based dentistry in clinical practice. *Journal of the American Dental Association (1939)*, 135(1), 78–83. Retrieved from <http://www.ncbi.nlm.nih.gov/pubmed/14959878>
- Ismail, A. I., Tellez, M., Pitts, N. B., Ekstrand, K. R., Ricketts, D., Longbottom, C., ... Zandona, A. (2013). Caries management pathways preserve dental tissues and promote oral health. *Community Dentistry and Oral Epidemiology*, 41(1), e12–e40. <http://doi.org/10.1111/cdoe.12024>
- Isong, I. A., Soobader, M.-J., Fisher-Owens, S. A., Weintraub, J. A., Gansky, S. A., Platt, L. J., & Newacheck, P. W. (2012). Racial Disparity Trends in Children's Dental Visits: US National Health Interview Survey, 1964–2010. *Pediatrics*, 130(2). <http://doi.org/10.1542/peds.2011-0838>
- Jahn, B., Theurl, E., Siebert, U., & Pfeiffer, K. P. (2010). Tutorial in medical decision modeling incorporating waiting lines and queues using discrete event simulation. *Value in Health*. <http://doi.org/10.1111/j.1524-4733.2010.00707.x>
- Jessee, S. (2008). Fulfilling the Promise of the Medicaid Act: Why the Equal Access Clause Creates Privately Enforceable Rights. *Emory Law Journal*, 58. Retrieved from <https://heinonline.org/HOL/Page?handle=hein.journals/emlj58&id=801&div=35&collection=journals>
- Jokela, J., & Pienihäkkinen, K. (2003). Economic evaluation of a risk-based caries prevention program in preschool children. *Acta Odontologica Scandinavica*, 61(2), 110–114. <http://doi.org/10.1080/00016350310002450>
- Jun, J. B., Jacobson, S. H., & Swisher, J. R. (1999). Application of Discrete-Event Simulation in Health Care Clinics: A Survey. *The Journal of the Operational Research Society*, 50(2), 109–123. <http://doi.org/10.2307/3010560>
- Jurasic, M. M., Gibson, G., Rich, S., O'Toole, T. G., Bestgen, S., Arola, P. E., & Jones, J. A. (2013). Leading determinants of efficient dental care delivery. *Journal of Public Health Dentistry*, 73(3), 195–203. <http://doi.org/10.1111/jphd.12013>
- Kahan, S., Gielen, A. C., Fagan, P. J., & Green, L. W. (Eds.). (2014). *Health Behavior Change in Populations*. John Hopkins University Press. Retrieved from <https://jhupbooks.press.jhu.edu/content/health-behavior-change->

populations

- Kaiser Commission on Medicaid and the Uninsured. (2012). *Oral Health in the US: Key Facts*. Retrieved from <https://kaiserfamilyfoundation.files.wordpress.com/2013/01/8324.pdf>
- Kakudate, N., Sumida, F., Matsumoto, Y., Yokoyama, Y., Riley, J. L., Gilbert, G. H., ... Gordan, V. V. (2015). Dentists' decisions to conduct caries risk assessment in a Dental Practice-Based Research Network. *Community Dentistry and Oral Epidemiology*, *43*(2), 128–34. <http://doi.org/10.1111/cdoe.12127>
- Kanellis, M. J., Damiano, P. C., & Momany, E. T. (2007). Medicaid Costs Associated with the Hospitalization of Young Children for Restorative Dental Treatment Under General Anesthesia. *Journal of Public Health Dentistry*, *60*(1), 28–32. <http://doi.org/10.1111/j.1752-7325.2000.tb03288.x>
- Kania, J., & Kramer, M. (2011). Collective Impact. *Stanford Social Innovation Review*. Retrieved from https://ssir.org/articles/entry/collective_impact
- Kao, R. T. (2006). The Challenges of Transferring Evidence-Based Dentistry into Practice. *Journal of Evidence Based Dental Practice*, *6*(1), 125–128. <http://doi.org/10.1016/j.jebdp.2005.12.011>
- Kaplan, G. A., Diez Roux, A. V., Simon, C. P., & Galea, S. (Eds.). (2017). *Growing inequality - bridging complex systems, population health, and health disparities*. Washington, D.C.: Westphalia Press.
- Kaste, L. M., Selwitz, R. H., Oldakowski, R. J., Brunelle, J. A., Winn, D. M., & Brown, L. J. (1996). Coronal Caries in the Primary and Permanent Dentition of Children and Adolescents 1–17 Years of Age: United States, 1988–1991. *Journal of Dental Research*, *75*(2_suppl), 631–641. <http://doi.org/10.1177/002203459607502S03>
- Keyes, P. H. P. (1962). Recent advances in dental caries research bacteriology. Bacteriological findings and biological implications. *International Dental Journal*, *12*, 443–464.
- Klinke, T., Urban, M., Lück, C., Hannig, C., Kuhn, M., & Krüger, N. (2014). Changes in *Candida* spp., mutans streptococci and lactobacilli following treatment of early childhood caries: A 1-year follow-up. *Caries Research*, *48*(1), 24–31. <http://doi.org/10.1159/000351673>
- Koczwara, B., Birken, S. A., Perry, C. K., Cragun, D., Zullig, L. L., Ginossar, T., ... Brownson, R. C. (2016). How Context Matters: A Dissemination and Implementation Primer for Global Oncologists. *Journal of Global Oncology*, *2*(2), 51–55. <http://doi.org/10.1200/JGO.2015.001438>
- Köhler, B., & Andréen, I. (2012). Mutans Streptococci and Caries Prevalence in Children after Early Maternal Caries Prevention: A Follow-Up at 19 Years of Age. *Caries Res*, *46*, 474–480. <http://doi.org/10.1159/000339665>
- Köhler, B., Andréen, I., & Jonsson, B. (1988). The earlier the colonization by mutans streptococci, the higher the caries prevalence at 4 years of age. *Oral Microbiology and Immunology*, *3*(1), 14–17. <http://doi.org/10.1111/j.1399-302X.1988.tb00598.x>
- Koppelman, J. (2016). States Expand the Use of Dental Therapy - Access to care increases when dentists are authorized to hire midlevel providers. Retrieved February 20, 2018, from <http://www.pewtrusts.org/en/research-and-analysis/analysis/2016/09/28/states-expand-the-use-of-dental-therapy>
- Kozai, K., Nakayama, R., Tedjosongko, U., Kuwahara, S., Suzuki, J., Okada, M., & Nagasaka, N. (1999). Intrafamilial Distribution of Mutans Streptococci in Japanese Families and Possibility of Father-to-Child Transmission. *Microbiology and Immunology*, *43*(2), 99–106. <http://doi.org/10.1111/j.1348-0421.1999.tb02380.x>

- Krasse, B. (2001). The Vipeholm Dental Caries Study: Recollections and Reflections 50 Years Later. *Journal of Dental Research*, 80(9), 1785–1788. <http://doi.org/10.1177/00220345010800090201>
- Kressin, N. R. (2005). Racial/Ethnic Disparities in Health Care: Lessons from Medicine for Dentistry. *Journal of Dental Education*, 69(9), 998–1002. Retrieved from <http://www.ncbi.nlm.nih.gov/pubmed/16141086>
- Kreuger, K., Flint MacBride, R., & Osgood, N. D. (2017). Beyond drill and fill: Modeling the impacts of risk-based care on oral health disparities. In G. A. Kaplan, A. Diez Roux, C. Simon, & S. Galea (Eds.), *Growing inequality: bridging complex systems, population health, and health disparities* (pp. 229–254). Washington, DC: Westphalia Press.
- Kwak, D.-Y., Kim, N.-Y., Kim, H.-J., Yang, S.-Y., Yoon, J.-E., Hyun, I.-A., & Nam, S.-H. (2017). Changes in the oral environment after tooth brushing and oral gargling. *Biomedical Research*, 28(16). Retrieved from <http://www.alliedacademies.org/articles/changes-in-the-oral-environment-after-tooth-brushing-and-oral-gargling-8220.html>
- Lapirattanakul, J., Nakano, K., Nomura, R., Hamada, S., Nakagawa, I., & Ooshima, T. (2008). Demonstration of Mother-to-Child Transmission of Streptococcus Using Multilocus Sequence Typing. *Caries Research*, 42(6), 466–474. <http://doi.org/10.1159/000170588>
- Law, V., Seow, W., & Townsend, G. (2007). Factors influencing oral colonization of mutans streptococci in young children. *Australian Dental Journal*, 52, 93–100. Retrieved from https://s3.amazonaws.com/objects.readcube.com/articles/downloaded/wiley/48bcfac832cf8abcd54d39047194001d60f003220fd7043f0ab0c07aeecd74f8.pdf?X-Amz-Algorithm=AWS4-HMAC-SHA256&X-Amz-Credential=AKIAIS5LBPCM5JPOCDGQ%2F20171112%2Fus-east-1%2Fs3%2Faws4_request&
- Lee, H. H., Milgrom, P., Starks, H., & Burke, W. (2013). Trends in death associated with pediatric dental sedation and general anesthesia. *Pediatric Anesthesia*, 23(8), 741–746. <http://doi.org/10.1111/pan.12210>
- Lee, J. Y., & Divaris, K. (2014). The Ethical Imperative of Addressing Oral Health Disparities: A Unifying Framework. *Journal of Dental Research*, 93(3), 224–230. <http://doi.org/10.1177/0022034513511821>
- Leischow, S. J., Best, A., Trochim, W. M., Clark, P. I., Gallagher, R. S., Marcus, S. E., & Matthews, E. (2008). Systems Thinking to Improve the Public's Health. *American Journal of Preventive Medicine*, 35(2), S196–S203. <http://doi.org/10.1016/j.amepre.2008.05.014>
- Leischow, S. J., & Milstein, B. (2006). Systems Thinking and Modeling for Public Health Practice. *American Journal of Public Health*, 96(3), 403–405. <http://doi.org/10.2105/AJPH.2005.082842>
- Levin, G., Roberts, E. B., Hirsch, G. B., Kligler, D. S., Roberts, N. H., & Wilder, J. F. (1976). *The Dynamics of Human Service Delivery*. (G. Levin & E. B. Roberts, Eds.). Cambridge, Mass: Ballinger Pub. Co.
- Lewis, C., Teeple, E., Robertson, A., & Williams, A. (2009). Preventive dental care for young, Medicaid-insured children in Washington state. *Pediatrics*, 124(1), e120-7. <http://doi.org/10.1542/peds.2008-3089>
- Lewis, V. A., Frazee, T., Fisher, E. S., Shortell, S. M., & Colla, C. H. (2017). ACOs Serving High Proportions Of Racial And Ethnic Minorities Lag In Quality Performance. *Health Affairs*, 36(1), 57–66. <http://doi.org/10.1377/hlthaff.2016.0626>
- Li, Y., & Caufield, P. W. (1995). The fidelity of initial acquisition of mutans streptococci by infants from their mothers. *Journal of Dental Research*, 74(2), 681–685. Retrieved from <http://jdr.sagepub.com/content/74/2/681.short>
- Li, Y., Lawley, M. A., Siscovick, D. S., Zhang, D., & Pagán, J. A. (2016). Agent-Based Modeling of Chronic Diseases: A Narrative Review and Future Research Directions. *Preventing Chronic Disease*, 13, E69.

<http://doi.org/10.5888/pcd13.150561>

- Li, Y., & Wang, W. (2002a). Predicting caries in permanent teeth from caries in primary teeth: an eight-year cohort study. *Journal of Dental Research*, *81*(8), 561–566. Retrieved from <http://jdr.sagepub.com/content/81/8/561.short>
- Li, Y., & Wang, W. (2002b). Predicting Caries in Permanent Teeth from Caries in Primary Teeth: An Eight-year Cohort Study. *Journal of Dental Research*, *81*(8), 561–566. <http://doi.org/10.1177/154405910208100812>
- Lingström, P., Holm, A., Mejåre, I., Twetman, S., Söder, B., Norlund, A., ... Källestål, C. (2003). Dietary factors in the prevention of dental caries: a systematic review. *Acta Odontologica Scandinavica*, *61*(6), 331–340. <http://doi.org/10.1080/00016350310007798>
- Lipscomb, J., & Scheffler, R. M. (1975). Impact of expanded-duty assistants on cost and productivity in dental care delivery. *Health Services Research*, *10*(1), 14–35. Retrieved from <http://www.ncbi.nlm.nih.gov/pubmed/812848>
- Liu, J., Probst, J. C., Martin, A. B., Wang, J.-Y., & Salinas, C. F. (2007). Disparities in dental insurance coverage and dental care among US children: the National Survey of Children's Health. *Pediatrics*, *119* Suppl 1(Supplement 1), S12-21. <http://doi.org/10.1542/peds.2006-2089D>
- Llena, C., & Calabuig, E. (2017). Risk factors associated with new caries lesions in permanent first molars in children: a 5-year historical cohort follow-up study. *Clinical Oral Investigations*, 1–8. <http://doi.org/10.1007/s00784-017-2253-5>
- Logan, H. L., Guo, Y., Dodd, V. J., Seleski, C. E., & Catalanotto, F. (2014). Demographic and practice characteristics of Medicaid-participating dentists. *Journal of Public Health Dentistry*, *74*, 139–146. <http://doi.org/10.1111/jphd.12037>
- Loper, M. L. (2015). The Modeling and Simulation Life Cycle Process. In M. Loper (Ed.), *Modeling and Simulation in the Systems Engineering Life Cycle - Core Concepts and Accompanying Lectures* (pp. 17–28). Atlanta, GA: Springer. Retrieved from <https://link.springer.com/content/pdf/10.1007%2F978-1-4471-5634-5.pdf>
- Lu, K. H. (1966). An Analysis of the Caries Process by Finite Absorbing Markov Chains. *Journal of Dental Research*, *45*(4), 998–1015. Retrieved from <http://journals.sagepub.com/doi/pdf/10.1177/00220345660450045501>
- Lutz, A. (2008). Who Joins the Military?: A Look at Race, Class, and Immigration Status. *Journal of Political and Military Sociology*, *36*(2), 167–188. Retrieved from <http://surface.syr.edu/soc>
- Mabry, P. L., & Kaplan, R. M. (2013). Systems Science. *Health Education & Behavior*, *40*(1_suppl), 9S–12S. <http://doi.org/10.1177/1090198113503469>
- Mabry, P. L., Milstein, B., Abraido-Lanza, A. F., Livingood, W. C., & Allegrante, J. P. (2013). Opening a Window on Systems Science Research in Health Promotion and Public Health. *Health Education & Behavior*, *40*(1 suppl), 5S–8S. <http://doi.org/10.1177/1090198113503343>
- Mabry, P. L., Olster, D. H., Morgan, G. D., & Abrams, D. B. (2008). Interdisciplinarity and Systems Science to Improve Population Health: A View from the NIH Office of Behavioral and Social Sciences Research. *American Journal of Preventive Medicine*, *35*(2, Supplement), S211-24. <http://doi.org/10.1016/j.amepre.2008.05.018>
- Maglio, P. P., Sepulveda, M.-J., & Mabry, P. L. (2014). Mainstreaming Modeling and Simulation to Accelerate Public Health Innovation. *American Journal of Public Health*, *104*(7), 1181–1186. <http://doi.org/10.2105/AJPH.2014.301873>

- Manice, M. P. (2013). *Exploring the relationship between parental shared decision-making practices and acute asthma exacerbations among children ages 0-17 - ProQuest*. Icahn School of Medicine at Mount Sinai. Retrieved from <https://search.proquest.com/docview/1430498337/abstract/69CE93A60C1A46C9PQ/1?accountid=14512>
- Manski, R. J., & Brown Jr, E. (2007). Chartbook# 17: Dental Use, Expenses, Dental Coverage, and Changes, 1996 and 2004. Retrieved from http://www.meps.ahrq.gov/data_files/publications/cb17/cb17.shtml
- Manski, R. J., & Rohde, F. (2017). *Dental Services: Use, Expenses, Source of Payment, Coverage and Procedure Type 1996-2015: (Research Findings No. 38)*. Rockville, MD. Retrieved from <http://www.meps.ahrq.gov/>
- Marinho, V. C. (2008). Evidence-based Effectiveness of Topical Fluorides. *Advances in Dental Research*, 20(1), 3–7. <http://doi.org/10.1177/154407370802000102>
- Marinho, V. C. (2009). Cochrane reviews of randomized trials of fluoride therapies for preventing dental caries. *European Archives of Paediatric Dentistry : Official Journal of the European Academy of Paediatric Dentistry*, 10(3), 183–191. <http://doi.org/10.1007/BF03262681>
- Marinho, V. C., Higgins, J. P., Logan, S., & Sheiham, A. (2002). Fluoride varnishes for preventing dental caries in children and adolescents. *Cochrane Database of Systematic Reviews*, 3(7), Art.No.:CD002279. <http://doi.org/10.1002/14651858.CD002278>
- Marinho, V. C., Higgins, J. P., Logan, S., & Sheiham, A. (2003). Fluoride toothpastes for preventing dental caries in children and adolescents. *Cochrane Database of Systematic Reviews*, 3(1), Art.No.:CD002278. <http://doi.org/10.1002/14651858.CD002278>
- Marinho, V. C., Higgins, J. P., Sheiham, A., & Logan, S. (2004a). Combinations of topical fluoride (toothpastes, mouthrinses, gels, varnishes) versus single topical fluoride for preventing dental caries in children and adolescents. *Cochrane Database of Systematic Reviews*. <http://doi.org/10.1002/14651858.CD002781.pub2>
- Marinho, V. C., Higgins, J. P., Sheiham, A., & Logan, S. (2004b). One topical fluoride (toothpastes, or mouthrinses, or gels, or varnishes) versus another for preventing dental caries in children and adolescents. *Cochrane Database of Systematic Reviews*. <http://doi.org/10.1002/14651858.CD002780.pub2>
- Marinho, V. C., Worthington, H. V., Walsh, T., & Clarkson, J. E. (2013). Fluoride varnishes for preventing dental caries in children and adolescents. *The Cochrane Database of Systematic Reviews*, (7), CD002279. <http://doi.org/10.1002/14651858.CD002279.pub2>
- Marshall, T. A. (2015). Nomenclature, characteristics, and dietary intakes of sugars. *Journal of the American Dental Association (1939)*, 146(1), 61–4. <http://doi.org/10.1016/j.adaj.2014.11.007>
- Marshman, Z., Ahern, S. M., McEachan, R. R. C., Rogers, H. J., Gray-Burrows, K. A., & Day, P. F. (2016). Parents' Experiences of Toothbrushing with Children. *JDR Clinical & Translational Research*, 1(2), 122–130. <http://doi.org/10.1177/2380084416647727>
- Martins, R. K., & McNeil, D. W. (2009). Review of Motivational Interviewing in promoting health behaviors. *Clinical Psychology Review*, 29(4), 283–293. <http://doi.org/10.1016/j.cpr.2009.02.001>
- Mattila, M. L., Rautava, P., Sillanpaa, M., & Paunio, P. (2000). Caries in five-year-old children and associations with family-related factors. *Journal of Dental Research*, 79(3), 875–881.
- Mattos-Graner, R. O., Li, Y., Caufield, P. W., Duncan, M., & Smith, D. J. (2001). Genotypic diversity of mutans streptococci in Brazilian nursery children suggests horizontal transmission. *Journal of Clinical Microbiology*, 39(6), 2313–6. <http://doi.org/10.1128/JCM.39.6.2313-2316.2001>

- May, C. R., Johnson, M., & Finch, T. (2016). Implementation, context and complexity. *Implementation Science*, 11(1), 141. <http://doi.org/10.1186/s13012-016-0506-3>
- Mayer, M. L., Stearns, S. C., Norton, E. C., & Rozier, R. G. (2000). The effects of Medicaid expansions and reimbursement increases on dentists' participation. *Inquiry : A Journal of Medical Care Organization, Provision and Financing*, 37(1), 33–44. Retrieved from <http://www.ncbi.nlm.nih.gov/pubmed/10892356>
- McGlone, P., Watt, R. G., & Sheiham, A. (2001). Evidence-based dentistry: an overview of the challenges in changing professional practice. *British Dental Journal*, 190(12), 636–639. <http://doi.org/10.1038/sj.bdj.4801062>
- Mckinnon, M., Luke, G., Bresch, J., Moss, M., Valachovic, R. W., & Mckinnon, M. M. (2007). Emerging Allied Dental Workforce Models: Considerations for Academic Dental Institutions. *Journal of Dental Education* ■, 71(11). Retrieved from <http://citeseerx.ist.psu.edu/viewdoc/download?doi=10.1.1.505.2363&rep=rep1&type=pdf>
- McPhee-Knowles, S. (2014). *THE COMPLEX PROBLEM OF FOOD SAFETY: APPLYING AGENT-BASED MODELING TO THE POLICY PROCESS*. University of Saskatchewan.
- Meadows, D. H. (1999). *Leverage Points Places to Intervene in a System*. Retrieved from http://donellameadows.org/wp-content/userfiles/Leverage_Points.pdf
- Meadows, D. H. (2008). *Thinking in Systems: A Primer*. (D. Wright, Ed.). White River Junction, Vt: Chelsea Green Publishing. Retrieved from <http://www.amazon.com/Thinking-Systems-Donella-H-Meadows/dp/1603580557>
- Mejare, I. A., Klingberg, G., Mowafi, F. K., Stecksén-Blicks, C., Twetman, S. H. A., & Tranæus, S. H. (2015). A Systematic Map of Systematic Reviews in Pediatric Dentistry—What Do We Really Know? *PLOS ONE*, 10(2), e0117537. <http://doi.org/10.1371/journal.pone.0117537>
- Memarpour, M., Fakhraei, E., Dadaein, S., & Vossoughi, M. (2015). Efficacy of fluoride varnish and casein phosphopeptide-amorphous calcium phosphate for remineralization of primary teeth: a randomized clinical trial. *Medical Principles and Practice : International Journal of the Kuwait University, Health Science Centre*, 24(3), 231–7. <http://doi.org/10.1159/000379750>
- Mertz, E. A. (2016). The dental-medical divide. *Health Affairs*, 35(12), 2168–2175. <http://doi.org/10.1377/hlthaff.2016.0886>
- Mertz, E. A., & Finocchio, L. (2010). Improving oral healthcare delivery systems through workforce innovations: an introduction. *Journal of Public Health Dentistry*, 70 Suppl 1(Suppl 1), S1-5. Retrieved from <http://www.ncbi.nlm.nih.gov/pubmed/20806470>
- Mertz, E. A., & Glassman, P. (2011). Alternative practice dental hygiene in California: past, present, and future. *Journal of the California Dental Association*, 39(1), 37–46. Retrieved from <http://www.ncbi.nlm.nih.gov/pubmed/21337961>
- Mertz, E. A., & O'Neil, E. (2002). The growing challenge of providing oral health care services to all Americans. *Health Affairs (Project Hope)*, 21(5), 65–77. <http://doi.org/10.1377/HLTHAFF.21.5.65>
- Mertz, E. A., Wides, C. D., Kottek, A. M., Calvo, J. M., & Gates, P. E. (2016). Underrepresented Minority Dentists: Quantifying Their Numbers And Characterizing The Communities They Serve. *Health Affairs*, 35(12), 2190–2199. <http://doi.org/10.1377/hlthaff.2016.1122>
- Metcalf, S. S., Northridge, M. E., Widener, M. J., Chakraborty, B., Marshall, S. E., & Lamster, I. B. (2013). Modeling Social Dimensions of Oral Health Among Older Adults in Urban Environments. *Health Education & Behavior*, 40(1 suppl), 63S–73S. <http://doi.org/10.1177/1090198113493781>

- Meyer, B. D., Lee, J. Y., Lampiris, L. N., Mihas, P., Vossers, S., & Divaris, K. (2017). "They Told Me to Take Him Somewhere Else": Caregivers' Experiences Seeking Emergency Dental Care for Their Children. *Pediatric Dentistry*, 39(3), 209–214. Retrieved from <http://www.ingentaconnect.com/contentone/aapd/pd/2017/00000039/00000003/art00007>
- Milgrom, P., Lee, R. S.-Y., Huebner, C. E., & Conrad, D. A. (2010). Medicaid reforms in Oregon and suboptimal utilization of dental care by women of childbearing age. *Journal of the American Dental Association (1939)*, 141(6), 688–95. <http://doi.org/10.14219/JADA.ARCHIVE.2010.0259>
- Milgrom, P., Mancl, L., King, B., Weinstein, P., Wells, N., & Jeffcott, E. (1998). An Explanatory Model of the Dental Care Utilization of Low-Income Children. *Source: Medical Care*, 36(4), 554–566. Retrieved from <http://www.jstor.org/stable/3767141>
- Military Health System Communications Office. (2017). Poor dental health leading cause of readiness issues | Health.mil. Retrieved January 28, 2018, from <https://health.mil/News/Articles/2017/02/24/Poor-dental-health-leading-cause-of-readiness-issues>
- Milstein, B. (2006). *Hygeia's Constellation: Navigating Health Futures in a Dynamic and Democratic World*. Union Institute & University. Retrieved from <http://search.proquest.com/pqdtglobal/docview/304914196/fulltextPDF/5C548A275A164F93PQ/1?accountid=14512>
- Milstein, B., & Homer, J. (2006). Background on System Dynamics Simulation Modeling With a Summary of Major Public Health Studies. *Systemswiki.Org*. Retrieved from [http://www.systemswiki.org/images/f/f5/SD_background_for_public_health_\(4.11.05\).pdf](http://www.systemswiki.org/images/f/f5/SD_background_for_public_health_(4.11.05).pdf)
- Milstein, B., Homer, J., & Hirsch, G. B. (2010). Analyzing National Health Reform Strategies With a Dynamic Simulation Model. *American Journal of Public Health*, 100(5), 811–819. <http://doi.org/10.2105/AJPH.2009.174490>
- Mitchell, S. T., Funkhouser, E., Gordan, V. V., Riley Iii, J. L., Makhija, S. K., Litaker, M. S., & Gilbert, G. H. (2017). Satisfaction with dental care among patients who receive invasive or non- invasive treatment for non-cavitated early dental caries: findings from one region of the National Dental PBRN. *BMC Oral Health*, 17. <http://doi.org/10.1186/s12903-017-0363-8>
- Mofidi, M., Rozier, R. G., & King, R. S. (2002). Problems With Access to Dental Care for Medicaid-Insured Children: What Caregivers Think. *American Journal of Public Health*, 92(1), 53–58. Retrieved from <http://www.ncbi.nlm.nih.gov/pmc/articles/PMC1447388/>
- Mouradian, W. E., & Corbin, S. B. (n.d.). Addressing Health Disparities Through Dental-Medical Collaborations, Part II. Cross-Cutting Themes in the Care of Special Populations. *Journal of Dental Education* ■, 67(12). Retrieved from <https://pdfs.semanticscholar.org/8675/d32ca666dea11b4d1d88318e28a27c70d9d6.pdf>
- Moynihan, P. J., & Kelly, S. A. M. (2014). Effect on Caries of Restricting Sugars Intake: Systematic Review to Inform WHO Guidelines. *Journal of Dental Research*, 93(1), 8–18. <http://doi.org/10.1177/0022034513508954>
- Mulligan, R., Seirawan, H., Faust, S., & Barzaga, C. (2011). Dental Caries in Underprivileged Children of Los Angeles. *Journal of Health Care for the Poor and Underserved*, 22(2), 648–662. <http://doi.org/10.1353/hpu.2011.0063>
- Murdoch-Kinch, C. A., & McLean, M. E. (2003). Minimally invasive dentistry. *Journal of the American Dental Association*, 134(1), 87–95. <http://doi.org/10.1038/bdj.2007.1191>
- Nagarkar, S. R., Kumar, J. V., & Moss, M. E. (2012). Early childhood caries-related visits to emergency departments and ambulatory surgery facilities and associated charges in New York state. *The Journal of the*

- American Dental Association*, 143(1), 59–65. <http://doi.org/10.14219/jada.archive.2012.0021>
- Nalliah, R. P., Allareddy, V., Elangovan, S., Karimbux, N., & Allareddy, V. (2010). Hospital Based Emergency Department Visits Attributed To Dental Caries in the United States in 2006. *Journal of Evidence Based Dental Practice*, 10(4), 212–222. <http://doi.org/10.1016/j.jebdp.2010.09.013>
- Nasseh, K., Vujicic, M., & O'Dell, A. (2013). Affordable Care Act expands dental benefits for children but does not address critical access to dental care issues. *Health Policy Resources Center Research Brief. American Dental Association*. Retrieved from https://pserprd.ada.org/sections/professionalResources/pdfs/HPRCBrief_0413_3.pdf
- National Institute of Dental and Craniofacial Research. (2018). The Story of Fluoridation. Retrieved June 3, 2018, from <https://www.nidcr.nih.gov/health-info/fluoride/the-story-of-fluoridation>
- National Institutes of Health (NIH). (2001). Diagnosis and Management of Dental Caries Throughout Life. *The National Institutes of Health (NIH) Consensus Statement Online*, 18(1), 1–24. Retrieved from <https://consensus.nih.gov/2001/2001dentalcaries115html.htm>
- Needleman, H. L., Bang, S., Zhou, J., Johnson, J. R., Mcpeek, B., & Graham, D. (2011). Personality Types of Pediatric Dentists: Comparative Analysis and Associated Factors. *Pediatric Dentistry*, 33(1), 37–45. Retrieved from <http://docserver.ingentaconnect.com/deliver/connect/aapd/01641263/v33n1/s7.pdf?expires=1524788854&id=0000&titleid=75004753&checksum=AD0803B6E2E883E1943C18EEFDE78832>
- Nelson, S., Whitsel, L., Khavjou, O., Phelps, D., & Leib, A. (2016). *Projections of Cardiovascular Disease Prevalence and Costs: 2015–2035 Technical Report*. Washington, DC. Retrieved from <https://healthmetrics.heart.org/wp-content/uploads/2017/10/Projections-of-Cardiovascular-Disease.pdf>
- Ng, M. W., Torresyap, G., White, A., Melvin, P., Graham, D., Kane, D., ... Ohiomoba, H. (2012). Disease Management of Early Childhood Caries: Results of a Pilot Quality Improvement Project. *Journal of Health Care for the Poor and Underserved*, 23(3A), 193–209. <http://doi.org/10.1353/hpu.2012.0122>
- Nianogo, R. A., & Arah, O. A. (2015). Agent-based modeling of noncommunicable diseases: a systematic review. *American Journal of Public Health*, 105(3), e20–31. <http://doi.org/10.2105/AJPH.2014.302426>
- Nilsen, P., Roback, K., Broström, A., & Ellström, P.-E. (2012). Creatures of habit: accounting for the role of habit in implementation research on clinical behaviour change. *Implementation Science*, 7(1), 53. <http://doi.org/10.1186/1748-5908-7-53>
- Northridge, M. E., & Metcalf, S. S. (2016). Enhancing implementation science by applying best principles of systems science. *Health Research Policy and Systems*, 14(1), 74. <http://doi.org/10.1186/s12961-016-0146-8>
- Nowjack-Raymer, R. E., & Sheiham, A. (2003). Association of Edentulism and Diet and Nutrition in US Adults. *Journal of Dental Research*, 82(2), 123–126. <http://doi.org/10.1177/154405910308200209>
- O'Neil, E., & Ngai, S. (2011). An opportunity for reform and oral health service. *Am j Public Health*, 101(10), E1–e3. Retrieved from <https://www.ncbi.nlm.nih.gov/pmc/articles/PMC3222363/>
- Oliva, R. (2003). Model calibration as a testing strategy for system dynamics models. *European Journal of Operational Research*, 151, 552–568. [http://doi.org/10.1016/S0377-2217\(02\)00622-7](http://doi.org/10.1016/S0377-2217(02)00622-7)
- Osgood, N. D. (2013). Overview of the Modeling Process. Retrieved from <https://pdfs.semanticscholar.org/presentation/0076/3573c1f1721c776c80f595d2e8183ff4961d.pdf>
- Osgood, N. D. (2014). Saskatoon ABM Bootcamp and Incubator 2014. Retrieved May 29, 2018, from

https://www.youtube.com/playlist?list=PLcAxwev2PmV-GxQIXNqgeW3xy7_-cUFSM

- Osgood, N. D. (2018). Why Simulation Modeling for Health in 10 min. *YouTube Channel*. Retrieved from <https://youtu.be/5m8a5cSaR10>
- Osgood, N. D., Dyck, R. F., & Grassmann, W. K. (2011). The inter- and intragenerational impact of gestational diabetes on the epidemic of type 2 diabetes. *American Journal of Public Health, 101*(1), 173–9. <http://doi.org/10.2105/AJPH.2009.186890>
- Osgood, N. D., Mahamoud, A., Lich, K. H., Tian, Y., Al-Azem, A., & Hoepfner, V. (2011). Estimating the Relative Impact of Early-Life Infection Exposure on Later-Life Tuberculosis Outcomes in a Canadian Sample. *Research in Human Development, 8*(1), 26–47. <http://doi.org/10.1080/15427609.2011.549692>
- Otto, M. (2007, February 28). For Want of a Dentist. *Washington Post*. Retrieved from www.washingtonpost.com/wp-dyn/content/article/2007/02/27/AR2007022702116.html
- Overstreet, Q. A., Dilworth, J. B., & Legler, D. W. (1978). Productivity and economic implication of a simulated practice using expanded duty dental assistants. *Community Dentistry and Oral Epidemiology, 6*(5), 233–239. <http://doi.org/10.1111/j.1600-0528.1978.tb01157.x>
- Pannu, P., Chawla, H.-S., Tewari, A., Gauba, K., Sujlana, A., Gambhir, R.-S., & Sagar, G. (2014). Correlation between mutans streptococci counts of parents and their children residing in Chandigarh, India. *J Clin Exp Dent, 6*(3), e250–4. <http://doi.org/10.4317/jced.51372>
- Patel, S. B., Curtis Bay, R., & Glick DMD, M. (2010). A Systematic Review of Dental Recall Intervals and Incidence of Dental Caries. *The Journal of the American Dental Association, 141*, 527–539. <http://doi.org/10.14219/jada.archive.2010.0225>
- Patrick, D. L., Shuk, R., Lee, Y., Nucci, M., Grembowski, D., Jolles, C. Z., ... Milgrom, P. (2006). Reducing Oral Health Disparities: A Focus on Social and Cultural Determinants. *BMC Oral Health, 6*(Suppl 4), 1–17. <http://doi.org/10.1186/1472-6831-6-S1-S4>
- Pearce, B., Hosseini, N., Taaffe, K., Huynh, N., & Harris, S. (2010). Modeling interruptions and patient flow in a preoperative hospital environment. In *Proceedings of the 2010 Winter Simulation Conference* (pp. 2261–2270). IEEE. <http://doi.org/10.1109/WSC.2010.5678924>
- Peres, M. A., Latorre, M. do R. D. de O., Sheiham, A., Peres, K. G., Barros, F. C., Hernandez, P. G., ... Victora, C. G. (2005). Social and biological early life influences on severity of dental caries in children aged 6 years. *Community Dentistry and Oral Epidemiology, 33*(1), 53–63. <http://doi.org/10.1111/j.1600-0528.2004.00197.x>
- Peres, M. A., Sheiham, A., Liu, P., Demarco, F. F., Silva, A. E. R., Assunção, M. C., ... Peres, K. G. (2016). Sugar Consumption and Changes in Dental Caries from Childhood to Adolescence. *Journal of Dental Research, 95*(4), 388–394. <http://doi.org/10.1177/0022034515625907>
- Pettersson, G., & Twetman, S. (2015). Caries risk assessment in young adults: a 3 year validation of the Cariogram model. *BMC Oral Health, 15*(1), 17. <http://doi.org/10.1186/1472-6831-15-17>
- Peyron, M., Matsson, L., & Birkhed, D. (1992). Progression of approximal caries in primary molars and the effect of Duraphat treatment. *European Journal of Oral Sciences, 100*(6), 314–318. <http://doi.org/10.1111/j.1600-0722.1992.tb01078.x>
- Phillips, K. A., Morrison, K. R., Andersen, R. M., & Aday, L. A. (1998). Understanding the Context of Healthcare Utilization: Assessing Environmental and Provider-Related Variables in the Behavioral Model of Utilization. *Health Services Research, 33*(3), 571–596. Retrieved from <https://www.ncbi.nlm.nih.gov/pmc/articles/PMC1070277/pdf/hsresearch00027-0142.pdf>

- Pienihäkkinen, K., & Jokela, J. (2002). Clinical outcomes of risk-based caries prevention in preschool-aged children. *Community Dentistry and Oral Epidemiology*, 30(2), 143–150. <http://doi.org/10.1034/j.1600-0528.2002.300208.x>
- Pienihäkkinen, K., Jokela, J., & Alanen, P. (2005). Risk-based early prevention in comparison with routine prevention of dental caries: a 7-year follow-up of a controlled clinical trial; clinical and economic aspects. *BMC Oral Health*, 5(2), 1–7. <http://doi.org/10.1186/1472-6831-5-2>
- Plsek, P. E. (2001). Redesigning Health Care with Insights from the Science of Complex Adaptive Systems. *Crossing the Quality Chasm*, 309–322. http://doi.org/10.1300/J022v19n03_03
- Plsek, P. E., & Greenhalgh, T. (2001). Complexity science: The challenge of complexity in health care. *BMJ (Clinical Research Ed.)*, 323(7313), 625–628. <http://doi.org/10.1136/bmj.323.7313.625>
- Pourat, N., & Marcus, M. (2011). Variations in self-reported provision of services by general dentists in private practice. *Journal of the American Dental Association (1939)*, 142(9), 1050–60. Retrieved from <http://www.ncbi.nlm.nih.gov/pubmed/21881073>
- Pourat, N., & Nicholson, G. (2009). *Unaffordable Dental Care Is Linked to Frequent School Absences*. Los Angeles, CA. Retrieved from [http://healthpolicy.ucla.edu/publications/Documents/PDF/Unaffordable Dental Care Is Linked to Frequent School Absences.pdf](http://healthpolicy.ucla.edu/publications/Documents/PDF/Unaffordable%20Dental%20Care%20Is%20Linked%20to%20Frequent%20School%20Absences.pdf)
- Pyle, M. A., & Stoller, E. P. (2003). Oral health disparities among the elderly: interdisciplinary challenges for the future. *Journal of Dental Education*, 67(12), 1327–36. Retrieved from <http://www.ncbi.nlm.nih.gov/pubmed/14733265>
- Ramazani, N. (2016). Different Aspects of General Anesthesia in Pediatric Dentistry: A Review. *Iranian Journal of Pediatrics*, 26(2), e2613. <http://doi.org/10.5812/ijp.2613>
- Ramirez de Arellano, A., Wolfe, S., & Public Citizen Health Research Group. (2011). *Unsettling Scores: A Ranking of State Medicaid Programs*. 2007.
- Ramos-Gomez, F. J. (2014). A Model for Community-Based Pediatric Oral Health: Implementation of an Infant Oral Care Program. *International Journal of Dentistry*, 2014, e156821. <http://doi.org/10.1155/2014/156821>
- Ramos-Gomez, F. J., Crystal, Y. O., Ng, M. W., Crall, J. J., & Featherstone, J. D. (2010). Pediatric Dental Care: Prevention and Management Protocols Based on Caries Risk Assessment. *Journal - California Dental Association*, 38(10), 746–761.
- Ramos-Gomez, F. J., & Ng, M.-W. (2000). Six Step Protocol for a Successful Infant Oral Care Visit. *Pediatric Dentistry Today*, November, 38–41.
- Rampa, S., Wilson, F. A., & Allareddy, V. (2016). Trends in dental-related emergency department visits in the State of California from 2005 to 2011. *Oral and Maxillofacial Surgery*, 122(4), 426–433. <http://doi.org/10.1016/J.OOOO.2016.05.003>
- Ramraj, C., Azarpazhooh, A., Dempster, L., Ravaghi, V., & Quiñonez, C. (2012). Dental treatment needs in the Canadian population: analysis of a nationwide cross-sectional survey. *BMC Oral Health*, 12, 46. <http://doi.org/10.1186/1472-6831-12-46>
- Rasanathan, K., Montesinos, E. V., Matheson, D., Etienne, C., & Evans, T. (2011). Primary health care and the social determinants of health: essential and complementary approaches for reducing inequities in health. *Journal of Epidemiology and Community Health*, 65(8), 656–60. <http://doi.org/10.1136/jech.2009.093914>
- Rashewsky, S., Parameswaran, A., Sloane, C., Ferguson, F., & Epstein, R. (2012). Time and cost analysis: pediatric

- dental rehabilitation with general anesthesia in the office and the hospital settings. *Anesthesia Progress*, 59(4), 147–53. <http://doi.org/10.2344/0003-3006-59.4.147>
- Ravitz, A. D., Sapirstein, A., Pham, J. C., & Doyle, P. A. (2013). Systems Approach and Systems Engineering Applied to Health Care: Improving Patient Safety and Health Care Delivery. *Johns Hopkins APL Technical Digest (Applied Physics Laboratory)*, 31(4), 354–365. Retrieved from http://www.jhuapl.edu/techdigest/TD/td3104/31_04-Ravitz.pdf
- Rechmann, P., Jue, B., Santo, W., Rechmann, B. M. T., & Featherstone, J. D. B. (2018). Calibration of dentists for Caries Management by Risk Assessment Research in a Practice Based Research Network - CAMBRA PBRN. *BMC Oral Health*, 18(1), 2. <http://doi.org/10.1186/s12903-017-0457-3>
- Reid, P. P., Compton, W. D., Grossman, J. H., & Fanjiang, G. (2005). *Building a Better Delivery System: A New Engineering/Health Care Partnership*. Retrieved from <http://www.nationalacademies.org/onpi/030909643X.pdf>
- Reilly, R. F. (2016). Medical and surgical care during the American Civil War, 1861-1865. *Proceedings (Baylor University. Medical Center)*, 29(2), 138–42. <http://doi.org/10.1080/08998280.2016.11929390>
- Reinhardt, U. (2012). Divide et impera: protecting the growth of health care incomes (COSTS). *Health Economics*, 21(1), 41–54. <http://doi.org/10.1002/hec.1813>
- Reisine, S. T., & Bailit, H. L. (1980). History and organization of pretreatment review, a dental utilization review system. *Public Health Reports (Washington, D.C. : 1974)*, 95(3), 282–90. Retrieved from <http://www.ncbi.nlm.nih.gov/pubmed/7384414>
- Reisine, S. T., & Douglass, J. M. (1998). Psychosocial and behavioral issues in early childhood caries. *Community Dentistry and Oral Epidemiology*, 26, 32–44.
- Repenning, N. P., & Serman, J. D. (2001). Nobody Ever Gets Credit for Fixing Problems that Never Happened: Creating and Sustaining Process Improvement. *California Management Review*, 43(4). <http://doi.org/10.2307/41166101>
- Rhodes, K. V., & Bisgaier, J. (2011). Limitations in Access to Dental and Medical Specialty Care for Publicly Insured Children. Retrieved from http://repository.upenn.edu/ldi_issuebriefs
- Rich III, J. P., Straffon, L., Inglehart, M. R., & Rohr Inglehart, M. (2006). Critical Issues in Dental Education General Dentists and Pediatric Dental Patients: The Role of Dental Education. *Journal of Dental Education* ■, 70(12), 1308–1315. Retrieved from <http://www.jdentaled.org/content/jde/70/12/1308.full.pdf>
- Robert Weyant, A. J., Tracy, S. L., Anselmo, T. T., Beltrán-Aguilar, E. D., Donly, K. J., Frese, W. A., ... Agents, A. D. A. C. on S. A. E. P. on T. F. C. P. (2013). Topical fluoride for caries prevention: Executive summary of the updated clinical recommendations and supporting systematic review. *The Journal of the American Dental Association*, 144(11), 1279–91. Retrieved from <http://www.ncbi.nlm.nih.gov/pubmed/24177407>
- Rogers, E. M. (1995). Lessons for Guidelines from the Diffusion of Innovations. *The Joint Commission Journal on Quality Improvement*, 21(7), 324–328. [http://doi.org/10.1016/S1070-3241\(16\)30155-9](http://doi.org/10.1016/S1070-3241(16)30155-9)
- Rosema, N. A. M., Slot, D. E., van Palenstein Helderma, W. H., Wiggelinkhuizen, L., & Van der Weijden, G. A. (2016). The efficacy of powered toothbrushes following a brushing exercise: A systematic review. *International Journal of Dental Hygiene*, 14(1), 29–41. <http://doi.org/10.1111/idh.12115>
- Roudsari, M. S., Shariatpanahi, S. P., Ahmady, A. E., & Khoshnevisan, M. H. (2016). Agent-Based Modeling: An Innovative Opportunity for Population-Based Oral Health Promotion. *Journal of Dentistry (Tehran, Iran)*, 13(2), 73–76. Retrieved from <http://www.ncbi.nlm.nih.gov/pubmed/27928234>

- Rowland, S., Leider, J. P., Davidson, C., Brady, J., & Knudson, A. (2016). Impact of a Community Dental Access Program on Emergency Dental Admissions in Rural Maryland. *American Journal of Public Health, 106*(12), 2165–2170. <http://doi.org/10.2105/AJPH.2016.303467>
- Rozier, R. G., White, B. A., & Slade, G. D. (2017). Trends in Oral Diseases in the U.S. Population. *Journal of Dental Education, 81*(8), eS97–eS109. <http://doi.org/10.21815/JDE.017.016>
- Sabounchi, N. S., Hovmand, P. S., Osgood, N. D., Dyck, R. F., & Jungheim, E. S. (2014). A novel system dynamics model of female obesity and fertility. *American Journal of Public Health, 104*(7), 1240–6. <http://doi.org/10.2105/AJPH.2014.301898>
- Sadeghipour, M., Khoshnevisan, M. H., Jafari, A., & Shariatpanahi, S. P. (2017). Friendship Network and Dental Brushing Behavior among Middle School Students: An Agent Based Modeling Approach. *PLoS One, 12*(1), e0169236. <http://doi.org/10.1371/journal.pone.0169236>
- Safarishahrbiari, A., Lawrence, T., Lomotey, R., Liu, J., Waldner, C., & Osgood, N. (2015). Particle filtering in a SEIRV simulation model of H1N1 influenza. In *2015 Winter Simulation Conference (WSC)* (pp. 1240–1251). IEEE. <http://doi.org/10.1109/WSC.2015.7408249>
- Sanches-Pereira, A., & Gómez, M. F. (2015). The dynamics of the Swedish biofuel system toward a vehicle fleet independent of fossil fuels. *Journal of Cleaner Production, 96*, 452–466. <http://doi.org/10.1016/J.JCLEPRO.2014.03.019>
- Sandström, A., Cressey, J., & Stecksén-Blicks, C. (2011). Tooth-brushing behaviour in 6-12 year olds. *International Journal of Paediatric Dentistry, 21*(1), 43–49. <http://doi.org/10.1111/j.1365-263X.2010.01080.x>
- Santos, C. L., & Douglass, J. M. (2008). Practices and Opinions of Pediatric and General Dentists in Connecticut Regarding the Age 1 Dental Visit and Dental Care for Children Younger Than 3 Years Old. *Pediatric Dentistry, 30*(4), 348–351. Retrieved from http://www.ingentaconnect.com/content/aapd/pd/2008/00000030/00000004/art00012?utm_source=TrendMD&utm_medium=cpc&utm_campaign=Pediatric_Dentistry_TrendMD_0
- Satcher, D. S. (2000). Surgeon General's report on oral health. *Public Health Reports, 115*(5), 489. Retrieved from <http://www.ncbi.nlm.nih.gov/pmc/articles/pmc1308610/>
- Savage, M. F. (2004). Early Preventive Dental Visits: Effects on Subsequent Utilization and Costs. *PEDIATRICS, 114*(4), e418–e423. <http://doi.org/10.1542/peds.2003-0469-F>
- Sbaraini, A., Carter, S. M., & Evans, R. W. (2011). How do dentists understand evidence and adopt it in practice? *Health Education Journal, 71*(2), 195–204. <http://doi.org/10.1177/0017896911434427>
- Scheffler, R. M. ., & Kushman, J. E. . (1977). A Production Function for Dental Services : Estimation and Economic Implications. *Southern Economic Journal, 44*(1), 25–35.
- Schuster, G. S. (1999). Oral flora and pathogenic organisms. *Infectious Disease Clinics of North America, 13*(4), 757–74, v. [http://doi.org/10.1016/S0891-5520\(05\)70107-0](http://doi.org/10.1016/S0891-5520(05)70107-0)
- Seale, N. S., & Casamassimo, P. S. (2003). Access to dental care for children in the United States - A survey of general practitioners. *The Journal of the American Dental Association, 134*(12), 1630–1640. <http://doi.org/10.14219/jada.archive.2003.0110>
- Senge, P. (2006). *The fifth discipline: The art and practice of the learning organization*. Doubleday. Retrieved from https://books.google.com/books?hl=en&lr=&id=OtyLDQAAQBAJ&oi=fnd&pg=PR11&ots=HpaD6HHNVA&sig=GfVM4o_7Ix9zuyvEi1A7ByWaPWs

- Shartzter, A., & Kenney, G. M. (2015). QuickTake: The Forgotten Health Care Need: Gaps in Dental Care for Insured Adults Remain under ACA | Health Reform Monitoring Survey. Retrieved April 8, 2018, from <http://hrms.urban.org/quicktakes/Gaps-in-Dental-Care-for-Insured-Adults-Remain-under-ACA.html>
- Sheiham, A., & James, W. P. T. (2014). A reappraisal of the quantitative relationship between sugar intake and dental caries: the need for new criteria for developing goals for sugar intake. *BMC Public Health*, *14*, 863. <http://doi.org/10.1186/1471-2458-14-863>
- Sheiham, A., & Watt, R. G. (2000). The Common Risk Factor Approach: a rational basis for promoting oral health. *Community Dentistry and Oral Epidemiology*, *28*(6), 399–406. <http://doi.org/10.1034/j.1600-0528.2000.028006399.x>
- Shimpi, N., Schroeder, D., Kilsdonk, J., Chyou, P.-H., Glurich, I., Penniman, E., & Acharya, A. (2016). MEDICAL PROVIDERS' ORAL HEALTH KNOWLEDGEABILITY, ATTITUDES, AND PRACTICE BEHAVIORS: AN OPPORTUNITY FOR INTERPROFESSIONAL COLLABORATION. *J Evid Base Dent Pract*, 19–29. <http://doi.org/10.1016/j.jebdp.2016.01.002>
- Shwartz, M., Gröndahl, H.-G., Pliskin, J. S., & Boffa, J. (1984). A Longitudinal Analysis from Bite-Wing Radiographs of the rate of Progression of Approximal Carious Lesions Through Human Dental Enamel. *Archs Oral Bid*, *29*(7), 529–536. Retrieved from https://ac.els-cdn.com/0003996984900748/1-s2.0-0003996984900748-main.pdf?_tid=3669682b-f8d2-48c1-a200-7ee80f8b4538&acdnat=1523514441_821358fc963526653a25d410abd1d7ed
- Simpson, K. N., Strassburger, A., Jones, W. J., Dietz, B., & Rajagopalan, R. (2009). Comparison of Markov Model and Discrete-Event Simulation Techniques for HIV. *PharmacoEconomics*, *27*(2), 159–165. <http://doi.org/10.2165/00019053-200927020-00006>
- Skaflida, V., & Chambers, S. (2017). Positive association between sugar consumption and dental decay prevalence independent of oral hygiene in pre-school children: a longitudinal prospective study. *Journal Of Public Health*. <http://doi.org/10.1093/pubmed/fox184>
- Skillman, S. M., Holly, M. C., Andrilla, A., Alves-Dunkerson, J. A., Mouradian, W. E., Comenduley, M., ... Doescher, M. P. (2009). *Washington State's Oral Health Workforce* (No. Final Report # 130). Retrieved from [http://depts.washington.edu/uwrhrc/uploads/CHWS FR130 Skillman 12-2-09.pdf](http://depts.washington.edu/uwrhrc/uploads/CHWS_FR130_Skillman_12-2-09.pdf)
- Sköld-Larsson, K., Modéer, T., & Twetman, S. (2000). Fluoride concentration in plaque in adolescents after topical application of different fluoride varnishes. *Clinical Oral Investigations*, *4*(1), 31–34. <http://doi.org/10.1007/s007840050110>
- Sladek, R. M., Phillips, P. A., & Bond, M. J. (2006). Implementation science: a role for parallel dual processing models of reasoning? *Implementation Science*, *1*(1), 12. <http://doi.org/10.1186/1748-5908-1-12>
- Slayton, R. L. (2015). Future directions. In *Early Childhood Oral Health* (pp. 317–328). Hoboken, NJ: John Wiley & Sons, Inc. <http://doi.org/10.1002/9781119101741.ch16>
- Sodequist, C., & Weber, C. (2016). Adaptive Learning - A Pivotal Competence for Collective Impact. Retrieved March 25, 2018, from <http://www.tamarackcommunity.ca/latest/adaptive-learning-a-pivotal-competence-for-collective-impact>
- Sognaes, R. F. (1948). ANALYSIS OF WARTIME REDUCTION OF DENTAL CARIES IN EUROPEAN CHILDREN: With Special Regard to Observations in Norway. *American Journal of Diseases of Children*, *75*(6), 792–821.
- Soni, A. Children's Dental Care: Advice and Checkups, Ages 2-17, 2008, Pub. L. No. #326 (2011). Rockville, MD. Retrieved from https://meps.ahrq.gov/data_files/publications/st326/stat326.pdf

- Spear, S. J. (2008). Chasing the Rabbit - Creating High Velocity Health Care Organizations. In *Scribd (Presentation)*. Institute for Healthcare Improvement. Retrieved from <https://www.scribd.com/document/161091042/Steven-Spear-Fixing-Healthcare>
- Standfield, L. B., Comans, T. A., & Scuffham, P. A. (2017). An empirical comparison of Markov cohort modeling and discrete event simulation in a capacity-constrained health care setting. *The European Journal of Health Economics, 18*(1), 33–47. <http://doi.org/10.1007/s10198-015-0756-z>
- Standfield, L., Comans, T., & Scuffham, P. (2014). MARKOV MODELING AND DISCRETE EVENT SIMULATION IN HEALTH CARE: A SYSTEMATIC COMPARISON. *International Journal of Technology Assessment in Health Care, 30*(02), 165–172. <http://doi.org/10.1017/S0266462314000117>
- Starfield, B. (2011). The hidden inequity in health care. *International Journal for Equity in Health, 10*(1), 15. <http://doi.org/10.1186/1475-9276-10-15>
- Sterman, J. D. (2000). *Business dynamics : systems thinking and modeling for a complex world*. Irwin/McGraw-Hill. Retrieved from https://books.google.com/books/about/Business_Dynamics.html?id=CCKCQgAACAAJ
- Sterman, J. D. (2002). All models are wrong: reflections on becoming a systems scientist. *System Dynamics Review, 18*(4), 501–531. <http://doi.org/10.1002/sdr.261>
- Sterman, J. D. (2006). Learning from evidence in a complex world. *American Journal of Public Health, 96*(3), 505–514. <http://doi.org/10.2105/AJPH.2005.066043>
- Stroh, D. P. (2015). *Systems Thinking For Social Change: A Practical Guide to Solving Complex Problems, Avoiding Unintended Consequences, and Achieving Lasting Results*. White River Junction, VT: Chelsea Green Publishing. Retrieved from https://books.google.com/books?hl=en&lr=&id=N1uZCgAAQBAJ&oi=fnd&pg=PA1&dq=stroh+population+and+system+thinking&ots=u_yDVM1jJy&sig=cslhHPXxyq34jekF8dIf_XQFXvY#v=onepage&q=stroh+population+and+system+thinking&f=false
- Sun, X., Bernabé, E., Liu, X., Gallagher, J. E., & Zheng, S. (2017). Early life factors and dental caries in 5-year-old children in China. *Journal of Dentistry, 64*, 73–79. <http://doi.org/10.1016/J.JDENT.2017.06.007>
- Swisher, J. R., Jacobson, S. H., Jun, J. B., & Balci, O. (2000). Modeling and analyzing a physician clinic environment using discrete-event (visual) simulation. *Computers and Operations Research, 27*(1), 1–14. [http://doi.org/10.1016/S0305-0548\(99\)00093-3](http://doi.org/10.1016/S0305-0548(99)00093-3)
- Swisher, J. R., Jacobson, S. H., Jun, J. B., & Balci, O. (2001). Modeling and analyzing a physician clinic environment using discrete-event (visual) simulation. *Computers & Operations Research, 28*(2), 105–125. Retrieved from <http://www.sciencedirect.com/science/article/pii/S0305054899000933>
- Taaffe, K., Fredendall, L., Huynh, N., & Franklin, J. (2015). Computer Simulation Shows the Effect of Communication on Day of Surgery Patient Flow. *AORN Journal, 102*(1), 60.e1-60.e14. <http://doi.org/10.1016/j.aorn.2015.05.005>
- Takeuchi, M. (1961). Epidemiological study on dental caries in Japanese children before, during and after World War II. *Int. Dent. J., 11*, 443–457. Retrieved from <https://ci.nii.ac.jp/naid/10010342481/>
- ten Cate, J. M., & Featherstone, J. D. B. (1991). Mechanistic Aspects of the Interactions Between Fluoride and Dental Enamel. *Critical Reviews in Oral Biology & Medicine, 2*(3), 283–296. <http://doi.org/10.1177/10454411910020030101>
- Tesfatsion, L. (2018). Verification and empirical validation of agent-based computational models. Retrieved from <http://www2.econ.iastate.edu/tesfatsi/empvalid.htm>

- Texas Medicaid & Healthcare Partnership. (2014). *Caries Risk Assessment Informational Procedure Codes*. Retrieved from [http://www.tmhp.com/News_Items/2014/01-Jan/01-17-14 Caries Risk Assessment Informational Procedure Codes Implemented January 1, 2014.pdf](http://www.tmhp.com/News_Items/2014/01-Jan/01-17-14_Caries_Risk_Assessment_Informational_Procedure_Codes_Implemented_January_1,_2014.pdf)
- The American Cancer Society. (2018). Economic Impact of Cancer. Retrieved January 30, 2018, from <https://www.cancer.org/cancer/cancer-basics/economic-impact-of-cancer.html>
- The Health Foundation. (2010). *Evidence Scan - Complex adaptive systems*. Retrieved from <https://www.health.org.uk/sites/health/files/ComplexAdaptiveSystems.pdf>
- Thomson, W. M., Poulton, R., Milne, B. J., Caspi, A., Broughton, J. R., & Ayers, K. M. S. (2004). Socioeconomic inequalities in oral health in childhood and adulthood in a birth cohort. *Community Dentistry and Oral Epidemiology*, *32*(5), 345–353. <http://doi.org/10.1111/j.1600-0528.2004.00173.x>
- Tian, Y., & Osgood, N. (n.d.). Comparison between Individual-based and Aggregate Models in the context of Tuberculosis Transmission. Retrieved from <https://www.anylogic.com/upload/iblock/969/969cb074de8ee57416f9f5556b11e450.pdf>
- Tickle, M., Blinkhorn, A. S., & Milsom, K. M. (2008). The Occurrence of Dental Pain and Extractions over a 3-Year Period in a Cohort of Children Aged 3-6 Years. *Journal of Public Health Dentistry*, *68*(2), 63–69. <http://doi.org/10.1111/j.1752-7325.2007.00048.x>
- Tickotsky, N., Petel, R., Araki, R., & Moskovitz, M. (2017). Caries Progression Rate in Primary Teeth: A Retrospective Study. *Journal of Clinical Pediatric Dentistry*, *41*(5), 358–361. <http://doi.org/10.17796/1053-4628-41.5.358>
- Tomoaia-Cotisel, A., Scammon, D. L., Waitzman, N. J., Cronholm, P. F., Halladay, J. R., Driscoll, D. L., ... Stange, K. C. (2013). Context matters: the experience of 14 research teams in systematically reporting contextual factors important for practice change. *Annals of Family Medicine*, *11 Suppl 1*(Suppl 1), S115-23. <http://doi.org/10.1370/afm.1549>
- Toverud, G. (1957). The Influence of War and Post-War Conditions on the Teeth of Norwegian School Children. II. Caries in the Permanent Teeth of Children Aged 7-8 and 12-13 Years. *The Milbank Memorial Fund Quarterly*, *35*(2), 127. <http://doi.org/10.2307/3348364>
- Tritten, C. B., & Armitage, G. C. (1996). Comparison of a sonic and a manual toothbrush for efficacy in supragingival plaque removal and reduction of gingivitis. *Journal of Clinical Periodontology*, *23*(7), 641–648. <http://doi.org/10.1111/j.1600-051X.1996.tb00588.x>
- Trochim, W. M., Cabrera, D. A., Milstein, B., Gallagher, R. S., & Leischow, S. J. (2006). Practical Challenges of Systems Thinking and Modeling in Public Health. *American Journal of Public Health*, *96*(3), 538–546. <http://doi.org/10.2105/AJPH.2005.066001>
- Trubey, R. J., Moore, S. C., & Chestnutt, I. G. (2015). Children's toothbrushing frequency: the influence of parents' rationale for brushing, habits and family routines. *Caries Research*, *49*(2), 157–64. <http://doi.org/10.1159/000365152>
- Trueblood, R., Kerins, C. A., & Seale, S. N. (2008). Caries Risk Assessment Practices Among Texas Pediatric Dentists. *Pediatric Dentistry*, *30*(1), 49–53(5). Retrieved from <http://www.ingentaconnect.com/content/aapd/pd/2008/00000030/00000001/art00010>
- Tsai, C., Wides, C., & Mertz, E. A. (2014). Dental workforce capacity and California's expanding pediatric Medicaid population. *J Calif Dent Assoc*, *42*(11), 757–764,766.
- Tsakos, G., Watt, R. G., Rouxel, P. L., de Oliveira, C., & Demakakos, P. (2015). Tooth Loss Associated with

- Physical and Cognitive Decline in Older Adults. *Journal of the American Geriatrics Society*, 63(1), 91–99.
<http://doi.org/10.1111/jgs.13190>
- Turbow, D. J., Osgood, N. D., & Jiang, S. C. (2003). Evaluation of recreational health risk in coastal waters based on enterococcus densities and bathing patterns. *Environmental Health Perspectives*, 111(4), 598–603.
 Retrieved from <http://www.ncbi.nlm.nih.gov/pubmed/12676622>
- Twetman, S. (2009). Caries prevention w F toothpaste in children. *European Archives of Paediatric Dentistry*, 10(3), 162–167.
- U.S. Census Bureau. (2017a). American FactFinder - Results. Retrieved from
<https://factfinder.census.gov/faces/tableservices/jsf/pages/productview.xhtml?src=bkmk>
- U.S. Census Bureau. (2017b). U.S. Census Bureau QuickFacts: UNITED STATES. Retrieved April 3, 2018, from
<https://www.census.gov/quickfacts/fact/table/DC,CA,FL,US/PST045217>
- U.S. Department of Health and Human Services. (2003). *A National Call to Action to Promote Oral Health* (No. NIH Publication No. 03-5303). Rockville, MD. Retrieved from
<http://www.ncbi.nlm.nih.gov/books/NBK47479/?report=printable>
- U.S. General Accounting Office (GAO). (2000). *Oral Health - Dental Disease is a Chronic Problem Among Low-Income Populations* (No. GAO/HEHS-00-72). *Report to Congressional Requesters*. Retrieved from
<http://www.gao.gov/new.items/he00072.pdf>
- U.S. Government Accountability Office (GAO). (2009, October 7). Medicaid: State and Federal Actions Have Been Taken to Improve Children’s Access to Dental Services, but More Can Be Done. Retrieved from
<https://www.gao.gov/products/GAO-10-112T>
- U.S. Government Accountability Office (GAO). (2008). *Medicaid: Extent of Dental Disease in Children Has Not Decreased* (No. GAO-08-1176T). Retrieved from <https://www.gao.gov/products/GAO-08-1176T>
- U.S. Department of Health and Human Services (DHHS). (2000). *Oral Health in America: A Report of the Surgeon General*. Rockville, MD. Retrieved from <http://www.nidcr.nih.gov/datastatistics/surgeongeneral/sgr/home.htm>
- Usha, C., & Sathyanarayanan, R. (2009). Dental caries - A complete changeover (Part I). *Journal of Conservative Dentistry : JCD*, 12(2), 46–54. <http://doi.org/10.4103/0972-0707.55617>
- van der Sanden, W. J. M., Mettes, D. G., Plasschaert, A. J. M., van’t Hof, M. A., Grol, R. P. T. M., & Verdonschot, E. H. (2003). Clinical practice guidelines in dentistry: opinions of dental practitioners on their contribution to the quality of dental care. *Quality & Safety in Health Care*, 12(2), 107–11.
<http://doi.org/10.1136/QHC.12.2.107>
- van Loveren, C., & Lingstöm, P. (2015). Diet and dental caries. In O. Fejerskov, B. Nyvad, & E. Kidd (Eds.), *Dental caries : the disease and its clinical management* (3rd ed., pp. 133–154). Oxford: Wiley Balckwell.
- van Ryn, M., & Fu, S. S. (2003). Paved with good intentions: Do public health and human service providers contribute to racial/ethnic disparities in health? *American Journal of Public Health*, 93(2), 248–255.
<http://doi.org/10.2105/AJPH.93.2.248>
- Vargas, C. M., Crall, J. J., & Schneider, D. A. (1998). Sociodemographic distribution of pediatric dental caries: NHANES III, 1988-1994. *Journal of the American Dental Association*, 129(9), 1229–38.
<http://doi.org/10.14219/jada.archive.1998.0420>
- Vargas, C. M., & Ronzio, C. R. (2002). Relationship between children’s dental needs and dental care utilization: United States, 1988-1994. *American Journal of Public Health*, 92(11), 1816–21.

<http://doi.org/10.2105/AJPH.92.11.1816>

- Vickers, D. M., & Osgood, N. D. (2014). The arrested immunity hypothesis in an immunoepidemiological model of Chlamydia transmission. *Theoretical Population Biology*, *93*, 52–62. <http://doi.org/10.1016/J.TPB.2014.01.005>
- Vickers, D. M., Zhang, Q., & Osgood, N. D. (2009). Immunobiological Outcomes of Repeated Chlamydial Infection from Two Models of Within-Host Population Dynamics. *PLoS ONE*, *4*(9), e6886. <http://doi.org/10.1371/journal.pone.0006886>
- Wall, Thomas P., & Vujicic, M. (2015). *Emergency Department Use for Dental Conditions Continues to Increase*. Retrieved from http://www.ada.org/~media/ADA/Science and Research/HPI/Files/HPIBrief_0415_2.ashx
- Wall, T. P., & Jackson Brown, L. (2007). The urban and rural distribution of dentists, 2000. *JADA*, *138*(7), 1003–11. <http://doi.org/10.14219/jada.archive.2007.0298>
- Wall, T. P., & Vujicic, M. (2015). Emergency Department Use for Dental Conditions Continues to Increase. *ADA Health Policy Institute*. Retrieved from http://www.ada.org/~media/ADA/Science and Research/HPI/Files/HPIBrief_0415_2.pdf?la=en
- Wallace, R., Geller, A., & Ayano, V. (2015). *Assessing the Use of Agent-Based Models for Tobacco Regulation*. Washington, DC. Retrieved from http://www.nap.edu/catalog.php?record_id=19018
- Walsh, T., Worthington, H. V., Glenny, A.-M., Appelbe, P., Marinho, V. C., & Shi, X. (2010). Fluoride toothpastes of different concentrations for preventing dental caries in children and adolescents. *Cochrane Database of Systematic Reviews*, (1), CD007868. <http://doi.org/10.1002/14651858.CD007868.pub2>
- Wan, A. K. L., Seow, W. K., Purdie, D. M., Bird, P. S., Walsh, L. J., & Tudehope, D. I. (2001). Oral Colonization of *Streptococcus mutans* in Six-month-old Predentate Infants. *Journal of Dental Research*, *80*(12), 2060–2065. <http://doi.org/10.1177/00220345010800120701>
- Wan, A. K. L., Seow, W. K., Walsh, L. J., Bird, P., Tudehope, D. I., & Purdie, D. M. (2001). Association of streptococcus mutans infection and oral developmental nodules in pre-dentate infants. *Journal of Dental Research*, *80*(10), 1945–1948. <http://doi.org/10.1177/00220345010800101601>
- Wang, H., Northridge, M. E., Kunzel, C., Zhang, Q., Kum, S. S., Gilbert, J. L., ... Metcalf, S. S. (2016). Modeling Social Capital as Dynamic Networks to Promote Access to Oral Healthcare. *Social, Cultural, and Behavioral Modeling*, *9708*, 117–130. Retrieved from <http://www.ncbi.nlm.nih.gov/pubmed/27668298>
- Wanyonyi, K. L., Radford, D. R., Harper, P. R., & Gallagher, J. E. (2015). Alternative scenarios: harnessing mid-level providers and evidence-based practice in primary dental care in England through operational research. *Human Resources for Health*, *13*(1), 78. <http://doi.org/10.1186/s12960-015-0072-9>
- Warren, E., Pollicino, C., Curtis, B., Evans, W., Sbaraini, A., & Schwarz, E. (2010). Modeling the long-term cost-effectiveness of the caries management system in an Australian population. *Value in Health*, *13*(6), 750–760. <http://doi.org/10.1111/j.1524-4733.2010.00759.x>
- Watt, R. G., McGlone, P., Evans, D., Boulton, S., Jacobs, J., Graham, S., ... Sheiham, A. (2004). The facilitating factors and barriers influencing change in dental practice in a sample of English general dental practitioners. *British Dental Journal*, *197*(8), 485–489. <http://doi.org/10.1038/sj.bdj.4811748>
- Watt, R. G., & Sheiham, A. (2012). Integrating the common risk factor approach into a social determinants framework. *Community Dentistry and Oral Epidemiology*, *40*(4), 289–296. <http://doi.org/10.1111/j.1600-0528.2012.00680.x>

- Weinstein, P. (2011). Motivational interviewing concepts and the relationship to risk management and patient counseling. *Journal of the California Dental Association*, 39(10), 742–745. Retrieved from <http://ovidsp.ovid.com/ovidweb.cgi?T=JS&CSC=Y&NEWS=N&PAGE=fulltext&D=emed11&AN=22132586%5Cnhttp://sfxeu08.hosted.exlibrisgroup.com/sgul?sid=OVID:embase&id=pmid:22132586&id=doi:&issn=1043-2256&isbn=&volume=39&issue=10&spage=742&pages=742-745&date=2011&titl>
- Weinstein, P., Harrison, R., & Benton, T. (2004). Motivating parents to prevent caries in their young children - One-year findings. *The Journal of the American Dental Association*, 135(6), 731–738. <http://doi.org/10.14219/jada.archive.2004.0299>
- Weintraub, J. A., Ramos-Gomez, F. J., Jue, B., Shain, S., Hoover, C. I., Featherstone, J. D. B., & Gansky, S. A. (2006). Fluoride Varnish Efficacy in Preventing Early Childhood Caries. *Journal of Dental Research*, 85(2), 172–176. <http://doi.org/10.1177/154405910608500211>
- Wen, A., Goldberg, D., Marrs, C. F., Weyant, R. J., Marazita, M. L., Srinivasan, U., ... Foxman, B. (2012). Caries resistance as a function of age in an initially caries-free population. *Journal of Dental Research*, 91(7), 671–675. <http://doi.org/10.1177/0022034512450174>
- Wilder, R. S. (2013). Dental hygienists and interprofessional collaboration: thoughts from 1927. *Journal of Dental Hygiene : JDH*, 87(3), 108–9. Retrieved from <http://www.ncbi.nlm.nih.gov/pubmed/23986326>
- Winpenny, E. M., Penney, T. L., Corder, K., White, M., & van Sluijs, E. M. F. (2017). Changes in consumption of added sugars from age 13 to 30 years: a systematic review and meta-analysis of longitudinal studies. *Obesity Reviews*, 18(11), 1336–1349. <http://doi.org/10.1111/obr.12588>
- Wolfe, J. D., Weber-Gasparoni, K., Kanellis, M. J., & Qian, F. (2006). Survey of Iowa General Dentists Regarding the Age 1 Dental Visit. *Pediatric Dentistry*, 28(4), 325–331. Retrieved from http://www.ingentaconnect.com/content/aapd/pd/2006/00000028/00000004/art00004?utm_source=TrendMD&utm_medium=cpc&utm_campaign=Pediatric_Dentistry_TrendMD_0
- Yarbrough, C., Nasseh, K., & Vujicic, M. (2014). Key Differences in Dental Care Seeking Behavior between Medicaid and Non-Medicaid Adults and Children. Retrieved from http://www.ada.org/~media/ADA/Science_and_Research/HPI/Files/HPIBrief_0814_4.pdf?la=en
- Yokoyama, Y., Kakudate, N., Sumida, F., Matsumoto, Y., Gilbert, G. H., & Gordan, V. V. (2013). Dentists' Dietary Perception and Practice Patterns in a Dental Practice-Based Research Network. *PLoS ONE*, 8(3), e59615. <http://doi.org/10.1371/journal.pone.0059615>
- Yokoyama, Y., Kakudate, N., Sumida, F., Matsumoto, Y., Gilbert, G. H., & Gordan, V. V. (2016). Evidence-practice gap for in-office fluoride application in a dental practice-based research network. *Journal of Public Health Dentistry*, 76(2), 91–97. <http://doi.org/10.1111/jphd.12114>
- York, A. K., Moss, D. L., & Martin, G. (2008). A Longitudinal Study of Dental Experience during the First Four Years of Military Experience. *Military Medicine*, 173(Supplement_1), 38–41. http://doi.org/10.7205/MILMED.173.Supplement_1.38
- Young, D. A., & Featherstone, J. D. B. (2013). Caries management by risk assessment. *Community Dentistry and Oral Epidemiology*, 41(1), e53–e63. <http://doi.org/10.1111/cdoe.12031>
- Zhang, J., Osgood, N., Grassmann, W., & Dyck, R. (n.d.). A System Simulation Model for Type 2 Diabetes in the Saskatoon Health Region. Retrieved from <https://pdfs.semanticscholar.org/0687/fcff6b8fd56faaf7f1efaf40d801e011fe28.pdf>
- Zimmerman, F. J. (2013). Habit, custom, and power: A multi-level theory of population health. *Social Science & Medicine*, 80, 47–56. <http://doi.org/10.1016/J.SOCSCIMED.2012.12.029>