

Lawrence Berkeley National Laboratory

Recent Work

Title

SUPERCONDUCTING PULSED DIPOLES FOR FUTURE ACCELERATORS

Permalink

<https://escholarship.org/uc/item/0zt6x38z>

Author

Gilbert, William S.

Publication Date

1972-09-01

Presented at the International Conference
on Magnet Technology, BNL, Upton, Long
Island, N. Y., Sept. 19-22, 1972

LBL-924

RECEIVED
LAWRENCE
RADIATION LABORATORY

LIBRARY AND
DOCUMENTS SECTION

**SUPERCONDUCTING PULSED DIPOLES FOR
FUTURE ACCELERATORS**

William S. Gilbert, Robert B. Meuser,
and Fred L. Toby

September 1972

AEC Contract No. W-7405-eng-48

For Reference

Not to be taken from this room



LBL-924

DISCLAIMER

This document was prepared as an account of work sponsored by the United States Government. While this document is believed to contain correct information, neither the United States Government nor any agency thereof, nor the Regents of the University of California, nor any of their employees, makes any warranty, express or implied, or assumes any legal responsibility for the accuracy, completeness, or usefulness of any information, apparatus, product, or process disclosed, or represents that its use would not infringe privately owned rights. Reference herein to any specific commercial product, process, or service by its trade name, trademark, manufacturer, or otherwise, does not necessarily constitute or imply its endorsement, recommendation, or favoring by the United States Government or any agency thereof, or the Regents of the University of California. The views and opinions of authors expressed herein do not necessarily state or reflect those of the United States Government or any agency thereof or the Regents of the University of California.

SUPERCONDUCTING PULSED DIPOLES FOR FUTURE ACCELERATORS

William S. Gilbert, Robert B. Meuser, Fred L. Toby
Lawrence Berkeley Laboratory
Berkeley, California

Abstract

Dipole No. 8 (inside diameter of winding, 3 in.; winding length, 18 in.; thickness of cold iron yoke, 2.2 in.) achieved short-sample performance: central field, 39.2 kG; maximum field in the conductor, 45 kG; current, 1920 A. That performance was maintained for a B of 5 kG/sec, corresponding to the voltage limit of the power supply. A higher-voltage power supply having a current limit of 1720 A was used to pulse the magnet to a maximum field of 35 kG at 1 Hz with a B of 70 kG/sec. The energy loss per cycle increased by a factor of 1.7 as B increased from zero to 70 kG/sec; much of this increase occurred in the iron. The loss in the coil is 40 watts at a peak central field of 35 kG and a frequency of 1 Hz, which for 10 μ diameter niobium titanium filaments corresponds to that calculated from the theory. After being pulsed 4600 cycles -- zero to 35 kG to zero -- the power loss and transition current were unchanged.

The iron-wire flux return yoke is being replaced with a thicker one of laminated electrical steel sheet, and a new magnet is being constructed by an improved method.

Introduction

We have been developing pulsed superconducting dipole magnets for use in future accelerators. The advantage of high field, low electrical power consumption, field constancy with time in the persistent mode, small physical size, and potential economy all combine to make slowly pulsed storage rings and boosters attractive systems for the inclusion of superconducting magnets. Rapidly pulsed synchrotrons can benefit even more from superconductivity when the more difficult developmental problems are solved.

Results of tests on our first six dipoles were reported previously, together with construction details and information about the superconductors used.¹

A seventh dipole, without an iron return yoke, using compacted cable is described in the above report. An improved eighth dipole with a thin iron yoke is the major subject of this report.

Dipole No. 8 DescriptionGeneral Configuration

Figure 1 shows the two-current-block con-

figuration used. A canted end shape results in a simplified winding method as well as a relatively low end-field rise (approximately 15%). The iron yoke is wound from rectangular soft iron wire 0.050 by 0.100 in. bonded with epoxy. Helium coolant channels are provided at the inside and outside of the coils, and the coils are permeable to helium.

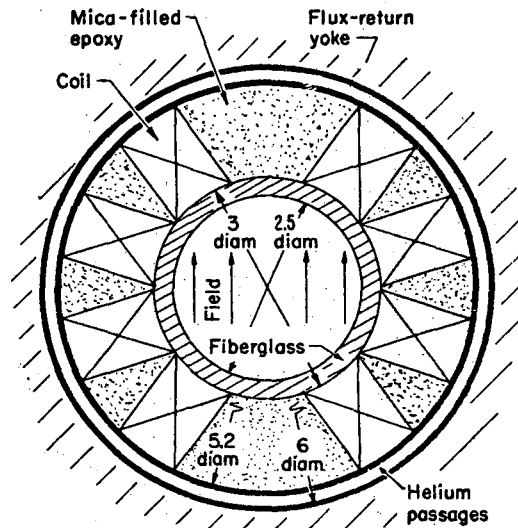

Figure 1. Coil cross section, Dipoles No. 8 and 8A. There are 72 turns in each of the coils nearest the horizontal axis, 54 in each of the other two. Angles of coil centers from the horizontal axis are 18 and 54 degrees. Dimensions are in inches.

Superconducting Cable

Superconducting NbTi-copper composite supplied by Cryomagnetics, Inc. was used in this magnet. The overall wire diameter is 0.008 in.; copper-to-superconductor ratio, 1.25; twist rate, 12 turns/in.; 211 filaments each about 10 μ diameter; insulation, silver-tin solder. One hundred thirty-three such wires were then cabled, 19 strands of 7 wires each, and subsequently compacted to a rectangular cross section.

Dipole No. 8 Performance

Figure 2 shows the load lines and conductor short-sample data for Dipoles No. 8, No. 8A, and No. 9. The central field of Dipole No. 8 was measured with a calibrated Hall probe. The departure of the excitation curve from linearity is due to the thinness of the iron wire yoke. Considerable training was required to reach the maximum current of 1920 A, which is close to 100% of material capability. At this current the maximum field in the end region of the coil is 45 kG, and the central bore field is 39.2 kG. The first transition, however, occurred at only some 80% of the maximum current achieved. We attribute the slow training to the relaxation of the epoxy-bonded structure.

Pulsed loss measurements were made with our new digital multiplier integrator technique that operates with the voltage and current signals from the magnets.² The magnet was pulsed to the limit of the voltage capability of the two power

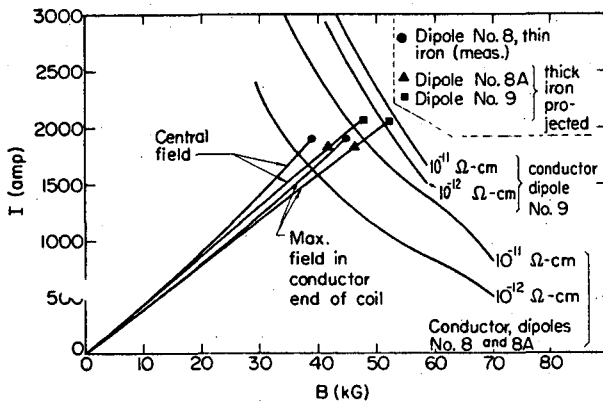

Figure 2. Load lines and short-sample data, Dipole No. 8, 8A, and 9.

supplies. Losses were determined at various currents in the frequency range 0.02 to 1 Hz. The increase in cycle loss with frequency is rather modest, with the hysteresis loss being equaled by the copper and iron eddy current losses at a B of 70 to 90 kG/sec. Figure 3 shows the hysteresis loss (for B = 0) as a function of maximum central field. The cyclic loss in the superconductor is estimated from solenoid tests with the same conductor; the iron loss is obtained by subtraction. At a B₀ of 35 kG, a frequency of 1 Hz, and a B of 70 kG/sec, the total power loss is some 70 W, with an estimated 40 W dissipation in the coil structure.

A short endurance test of several days was run with B₀ = 35 kG, f = 0.1 Hz; this rate was chosen to roughly match the helium liquefaction rate of our 500 Inc. Model 1200 refrigerator. 4600 cycles were logged, and the magnet was then transitioned at 1920 A; the same value as before. Table 1 shows some of the test results for Dipole No. 8, together with that for some earlier magnets.

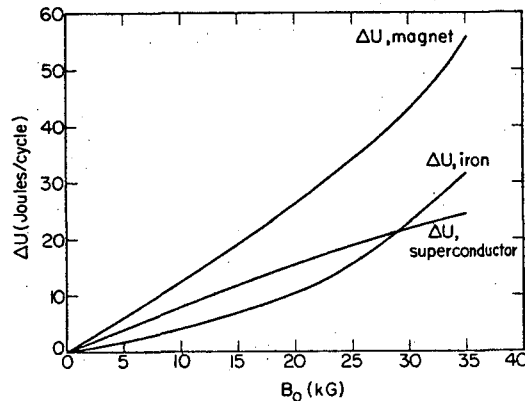

Figure 3. Energy loss measurements, Dipole No. 8.

Table 1 Summary of Magnet Characteristics

Dipole Number	Wire and Cable	Description	B _{max} (kG)			Space Factor Metal Volume Total Coil Volume	Coil Current Density (kA/cm ²)
			Central Field	End Field	% Short Sample		
4	49 Wire Cable (7x7), not compacted. 7μ filaments. Formvar insulation. Iron wire yoke	Winding fairly loose. Cable movement observed. Iron wire yoke	23	32	70	0.25	11.6
5	Same as in #4 above except silver-tin metallic insulation.	Winding loose No iron yoke	27	38	100	0.28	19.5
6	Same as #5 except some damaged cable was used.	Thicker insulation than Magnet #5. No iron	26	29	80	0.21	13.0
7	49 cable (7x7) Compacted to square, 10μ filaments, silver-tin insulation.	Epoxy fiberglass insulation. Solid structure - no observed wire movement.	27	29	90	0.32	17.4
8	133 cable (19x7). Compacted to rectangle. 10μ filaments. Silver-tin insulation.	Structure as Magnet #7. Iron wire yoke.	39	45	100	0.47	21.1

Dipole No. 8 -- Construction

The cable is passed through a non-powered turk's-head, reducing its cross-section from 0.120-in. diam. to a 0.078 by 0.114-in. rectangle, measured just as the cable leaves the turk's-head. After the cable is passed through straightening rolls, to eliminate the twist introduced by the compaction, and with no tension applied, the cable measured 0.082 by 0.117 in.

Subsequently, the cable is wrapped with 0.125-in.-wide Dacron woven tape which is impregnated with a thinned epoxy resin. The epoxy dries, but does not cure, immediately after the wrapping.

An epoxy-fiberglass tube, over which the coils are installed, is grooved longitudinally and circumferentially to provide passages for liquid helium. A thick-walled cylinder of mica-filled epoxy is cast; its inside diameter matches the outside diameter of the epoxy fiberglass tube, and its outside diameter matches the outside diameter of the winding. Channels are milled into the cylinder where the conductors are to be placed, separating the cylinder into five pieces, some of which are sawn into smaller pieces to facilitate assembly. The pieces are secured to the fiberglass cylinder with bronze screws at appropriate stages of the assembly.

The milling operation forms the ends of the pieces over which the coils are wound to only a rough approximation of the desired shape. That shape is one taken by a simply-curved thin flat strip laid in place of the first layer of the winding, in the manner of the early Brookhaven niobium-tin dipole magnets. Conductors subsequently laid along such a surface exhibit no tendency to move toward either edge under the influence of the tension in the cable. All turns of a layer have the same length: a necessary but not sufficient condition for neutral stability. A strip of metal, bent to represent the inside of the first layer of conductor, is used to mold a thin layer of polyester-base auto-body putty onto the end of the milled winding form to the final shape.

Winding proceeds from inside to outside on one layer, outside to inside on the next, and so forth. Small wedges of bakelite are placed to fill the voids left when the cable crosses over from one layer to the next. The cross-overs occur in the straight-section of the coil.

Each of the four coils is made separately, clamped to confine the coil to the desired shape, and baked to set the epoxy resin in the Dacron wrapping. The space finally occupied by each turn is a rectangle 0.102 by 0.139; the final space factor (metal area \div coil window area) is 0.47. (Figure 4)

The two sets of windings are assembled over the fiberglass tube along with all of the remaining filler pieces machined from the mica-epoxy tube. (Figure 5) Dacron string is wrapped around

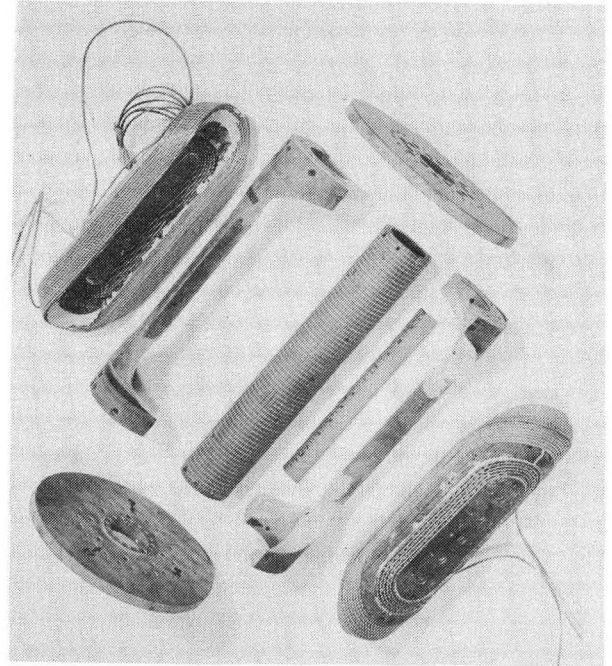

Figure 4. Parts for Dipole No. 8 and 8A.

the outside to form circumferential helium passages. Strips of bakelite secured over the string by a second winding of string form longitudinal passages. A polyester sheet barrier is taped to the outside.

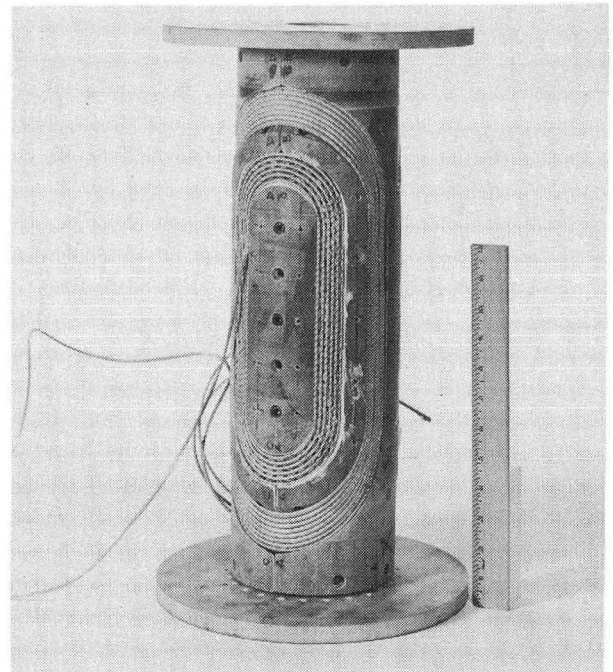

Figure 5. Dipole No. 8 and 8A prior to adding outer helium channels and flux-return yoke.

The iron yoke, made of soft iron wire of .050 x .100-in. cross section, is wound on the outside while epoxy resin is painted on, and finally the magnet is barbecued under heat lamps to set the resin.

Dipole No. 8A

The thin iron-wire yoke of Dipole No. 8 is being replaced with one made of electrical steel sheet laminations (Grade M-19, 24 ga.) Figure 6 shows both the new and the old yokes. This is expected to result in reduced eddy current and hysteresis losses, and a slight increase in field strength. Extensive magnetic measurements are planned.

Dipole No. 9

Experiments on a new winding technique have been completed, and tooling has been built to apply the new technique to the construction of Dipole No. 9. An experimental coil made by the new method is shown in Figure 7. The cross-section of the magnet will be similar to that of Dipole No. 8 except that it will have three current blocks per pole instead of two. The block centers will be at angles of $1/7$, $3/7$, and $5/7$ of a right angle from the horizontal, and the turns-per-block will approximate the ratios 1:0.802:0.445 prescribed by Beth.³ The laminated flux-return yoke from Magnet No. 8A will be used.

References

1. William S. Gilbert, Robert B. Meuser, and Ferdinand Voelker, Test Results -- Pulsed Superconducting Synchrotron-Type Dipole Magnets, in Proceedings of the 8th International Conference on High-Energy Acceleration, Geneva, CERN, 1971.
2. W. Gilbert, F. Voelker, R. Acker, J. Kaugerts, Coupling in Superconducting Braids and Cables, in Proceedings of the 1972 Applied Superconductivity Conference, Annapolis, Md. (to be published.)
3. Richard A. Beth, Analytical Design of Superconducting Multipolar Magnets, in Proceedings of the 1968 Summer Study on Superconducting Devices and Accelerators, Brookhaven National Lab., BNL50155(C-55).

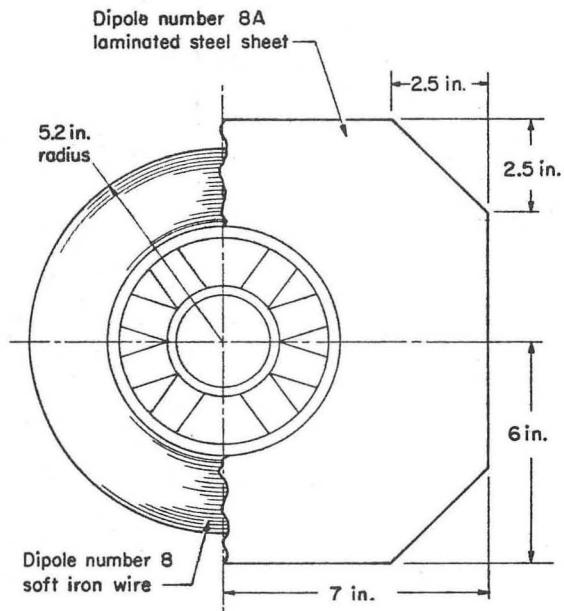

Figure 6. Flux-return yokes for Dipoles No. 8 and 8A.

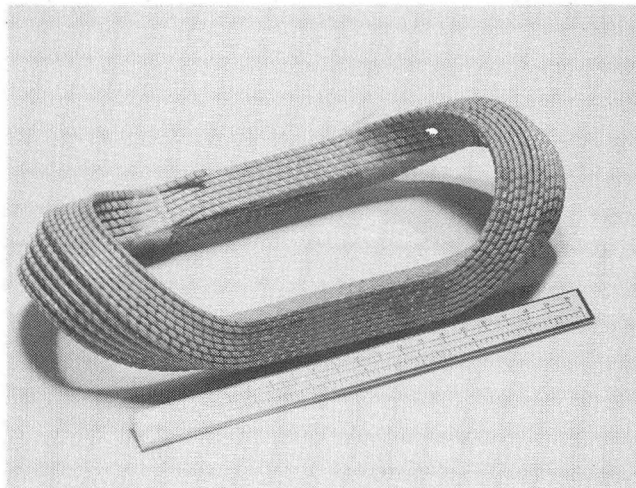

Figure 7. Experimental coil for Dipole No. 9 made by a new method.

This work performed under the auspices of the Atomic Energy Commission.

LEGAL NOTICE

This report was prepared as an account of work sponsored by the United States Government. Neither the United States nor the United States Atomic Energy Commission, nor any of their employees, nor any of their contractors, subcontractors, or their employees, makes any warranty, express or implied, or assumes any legal liability or responsibility for the accuracy, completeness or usefulness of any information, apparatus, product or process disclosed, or represents that its use would not infringe privately owned rights.

TECHNICAL INFORMATION DIVISION
LAWRENCE BERKELEY LABORATORY
UNIVERSITY OF CALIFORNIA
BERKELEY, CALIFORNIA 94720