

Lawrence Berkeley National Laboratory

Lawrence Berkeley National Laboratory

Title

Development of a High-Brightness VHF Electron Source at LBNL

Permalink

<https://escholarship.org/uc/item/0zr8x766>

Authors

Lidia, Steven M.
Sannibale, Fernando
Staples, John W.
et al.

Publication Date

2008-05-09

DEVELOPMENT OF A HIGH-BRIGHTNESS VHF ELECTRON SOURCE AT LBNL*

S. Lidia[#], F. Sannibale, J. Staples, S. Virostek, R. Wells, LBNL, Berkeley, CA, USA

Abstract

Currently proposed ERL and high average power FEL projects require electron beam sources that can generate $\sim 1\text{nC}$ bunch charges at high repetition rates. Many proposed sources are based around either high voltage DC or microwave RF guns, each with its particular set of technological limits and system complications. We propose a novel solution that greatly diminishes high voltage breakdown issues while also decreasing peak RF power requirements in a warm copper device, and that has the benefit of mapping the rf oscillation period much more closely to the required beam repetition rate. We present the initial RF and mechanical design for a 750kV electron source and beam injection system utilizing a gun resonant in the VHF band. Beam dynamics simulations demonstrate excellent beam quality preservation and transport.

INTRODUCTION

Current projects in linac and ERL soft-xray-VUV FELs require injection of $\sim 100\text{pC}$ - 1nC electron bunches at repetition rates from kHz to GHz [1]. After acceleration to only 1- GeV, lasing requires the beam's normalized emittance to be significantly lower than $\sim 1\text{mm-mrad}$. This places additional burdens on the cathode, gun and injector systems. Limiting early emittance growth requires minimum (unloaded) accelerating gradients in the gun of $\sim 20\text{MV/m}$ and gun voltages of $\sim 500\text{kV}$ or higher.

Maintaining these fields in a DC gun can require heroic effort to prevent insulator breakdown. In high-frequency (L- to S-band) normal-conducting rf guns, average power loading in the cavity structure limits the practical repetition rate to the kHz range. Superconducting, high-frequency cavities are likely candidates photoinjectors, but are prevented by flux exclusion from easily placing a solenoid magnetic field to thread flux through the cathode for emittance manipulation techniques [2].

Many experiments utilizing single-pulse pump-probe techniques only require pulses to arrive at repetition rates in the 100kHz – 1MHz range. A low-frequency (VHF or ~ 100 's MHz) may be an attractive technological alternative. High quality beam may be generated at $\sim 1\text{MHz}$ rates and used to drive multiple FEL beamlines at $\sim 100\text{kHz}$ rates.

Currently, the only operational VHF band photoinjector is used to drive the ELSA 19MeV linac [3]. This experiment has been in operation since 1992. The

144MHz photoinjector gun has shown to produce 1nC , 60ps bunches with normalized, transverse emittances of $\sim 1\text{mm mrad}$ at the linac exit. Even though the duty cycle of the is limited to $150\mu\text{s}$ macropulses at 10Hz repetition rates, this system nonetheless has demonstrated high brightness beam production with reasonable bunch charges in a low frequency rf photoinjector system.

QUARTER-WAVE COAXIAL VHF GUN

The quarter-wave coaxial gun is shown schematically in Figure 1 below. The photoinjector gun uses a re-entrant cavity structure, requiring less than 100kW CW, with a peak wall power density less than 10W/cm^2 [4]. RF power sources may be based on commercially available broadcast tubes.

The normal-conducting structure may be fabricated from copper-plated aluminum. The cavity will support a vacuum down to 10picoTorr, with a load-lock mechanism for easy replacement of photocathodes. The large anode wall is slightly curved to provide greater stiffness against deflection under high vacuum. An all-metal structure is suitable for bake-out procedures, and the large outer diameter provides excellent accessibility for ion-, cryo-, and getter- pumps.

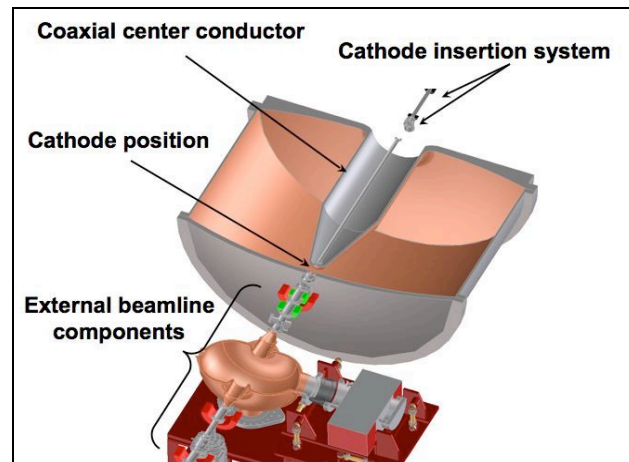

Figure 1: Schematic of a quarter-wave coaxial VHF gun.

The cathode may be embedded in a solenoid magnetic field to provide correlations in the emitted beam phase space that are useful for emittance exchange.

A nose-mounted magnetic solenoid has been designed to run in a 'bucking' configuration to either nullify the on-axis magnetic flux, or to provide up to $\sim 700\text{Gauss}$ at the cathode plane (Figure 2).

*Work supported by the Office of Science, U.S. Department of Energy, under Contract No. DE-AC02-05CH11231.
[#]smlidia@lbl.gov

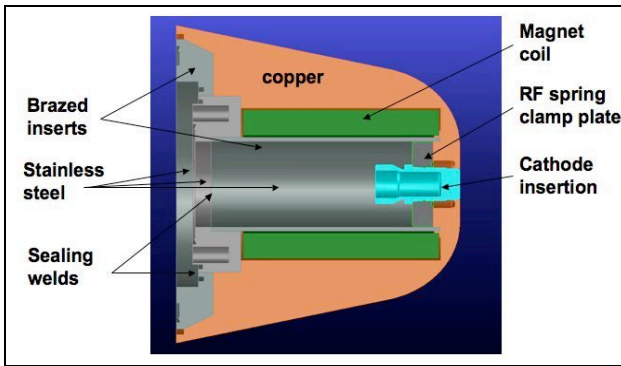

Figure 2: Gun nose assembly schematic.

INJECTOR BEAM DYNAMICS

The VHF gun is designed to provide long pulse (several 10s picoseconds) electron beams to an injection system for additional acceleration, velocity bunch compression, and emittance compensation/manipulation prior to further acceleration up to $\sim 1\text{-}2\text{GeV}$ and injection into FEL undulators [1]. We are in the process of designing a test beamline for the low energy photoinjector.

Advanced Photoinjector Experiment (APEX)

The APEX beamline concept addresses fundamental issues in high average current, high brightness beam production for soft x-ray FEL applications. These include studies of photocathode quantum efficiency, charge production, pulse shaping, and cathode lifetime; emittance manipulation, including pulse compression, emittance compensation, and emittance exchange; beam transport and high current instabilities in superconducting linac structures; and beam measurements and diagnostic development for ultra-low emittance beams.

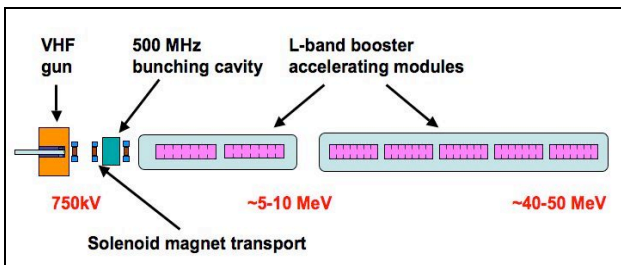

Figure 3: APEX photoinjector beamline.

The beamline is shown schematically in Figure XXX above. The main components of the injector are the 750kV VHF gun, a UHF single-cell bunching cavity ($\sim 500\text{-}800\text{MHz}$), and an L-band pre-booster linac to $\sim 10\text{MeV}$ followed by another L-band booster for acceleration up to $\sim 100\text{MeV}$. Solenoid magnets provide transverse focusing and beam transport between the RF elements. The bunching cavity introduces an energy chirp sufficient to allow compression of the beam to 2mm RMS length ($\sim 6.7\text{ps}$ RMS). The pre-booster takes the beam from a mildly relativistic energy ($\sim 750\text{kV}$) to a highly

relativistic energy ($\sim 10\text{MeV}$) while completing the longitudinal compression and matching the transverse beam parameters to allow for complete emittance compensation in the final injector linac module.

Beam Dynamics Simulations

ASTRA [5] simulations are used to model the performance of the RF gun and beamline during the design and optimization process. The beam parameters at the photocathode are given in Table 1. The thermal emittance of the emitted beam is taken to be very small to better study the effects of the space charge and the low frequency RF components on the evolution of beam quality in the photoinjector beamline. More realistic values may be used that are dependent upon the actual photocathode material and drive laser wavelength, once the optimized beamline design produces beams that achieve the thermal emittance limit after emittance compensation is complete at higher beam energies.

Table 1: Beam parameters at emission.

Bunch charge	500	pC
Long. distribution	Flattop	
Bunch length (FWHM)	75	ps
RMS energy spread	0.1	eV
Transverse profile	Parabolic	
Spot size (RMS)	0.5	mm
Thermal emittance	0.05	mm-mrad

The evolution of the main beam parameters are shown in Figure 4 from generation at the photocathode ($z=0\text{m}$) to beyond the exit of the second linac module ($z=15\text{m}$). At this point the beam has an average energy of $\sim 45\text{MeV}$, bunch length (duration) of 2mm ($\sim 6.7\text{ps}$ RMS) with peak current $\sim 32\text{Amperes}$. Emittance compensation has been carried out, with the final projected, normalized emittance $\sim 0.5\text{mm-mrad}$.

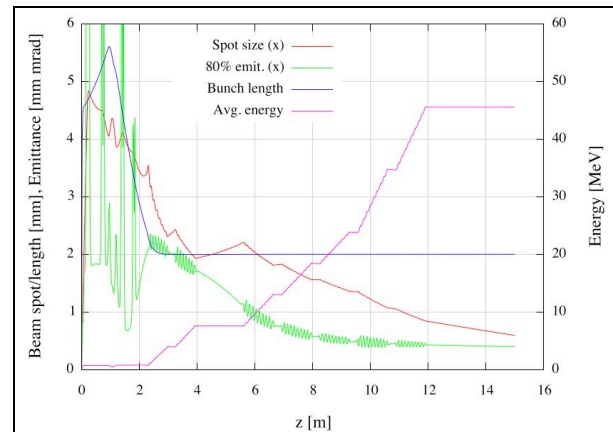

Figure 4: Evolution of beam quality in the photoinjector.

The variation of the slice current and normalized emittance at the injector exit ($z=15\text{m}$) is shown in Figure

5. After compression, the longitudinal profile takes on a skewed, pseudo-Gaussian distribution. The average value of the slice emittance (weighted by slice charge) is $\sim 0.35\text{mm-mrad}$.

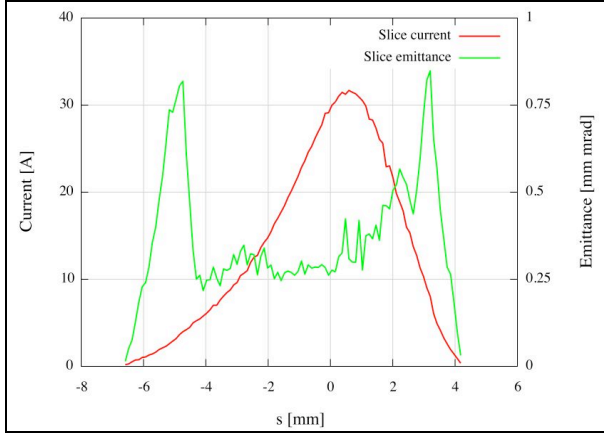

Figure 5: Slice current and emittance at the photoinjector exit ($z=15\text{m}$).

GUN GEOMETRY OPTIMIZATION STUDIES

We have performed a number of optimization studies to the VHF gun cavity geometry to minimize stored energy, peak thermal surface loading and cooling requirements, the required RF power, multipacting region area, while maximizing beam quality at the injector exit. The RF behavior, and thermal and structural analysis of the structure is discussed elsewhere [4]. Here, we discuss issues of the cavity geometry that impact beam quality.

With a resonant frequency between 50-200MHz, gap voltage of 750kV over 4cm, and beam pulse length $<100\text{ps}$, the beam subtends a very small fraction of the RF period. Hence, the already optimized solutions of DC photoinjectors may be applied to the design of the VHF gun, at least in terms of single bunch beam dynamics. We are interested, then, in studying what effects exist on the ultimate beam quality at the high-energy exit of the injector due to variations in the geometry of the electrodes that comprise the accelerating gap, and to variations of the cavity resonant frequency over the $\sim 50\text{-}200\text{MHz}$ band.

Gap design and variations

We have produced cavity geometries at a fixed resonant frequency (65MHz) but with varying amounts of curvature in the cathode electrode. A flat cathode geometry will maximize the voltage gradient at the cathode surface, while increasing curvature will increase the radial (focusing) component of the electric field at the expense of the longitudinal (accelerating) component. Figure 6 displays the longitudinal electric field along the beam axis in the gap region for various cathode

geometries. As seen, there are several distinct classes of geometry: (i) no focusing, flat cathode; (ii) weak focusing, with moderate curvature of the cathode surface; (iii) strong focusing, with greater curvature; and (iv) longer anode-cathode (AK) gap.

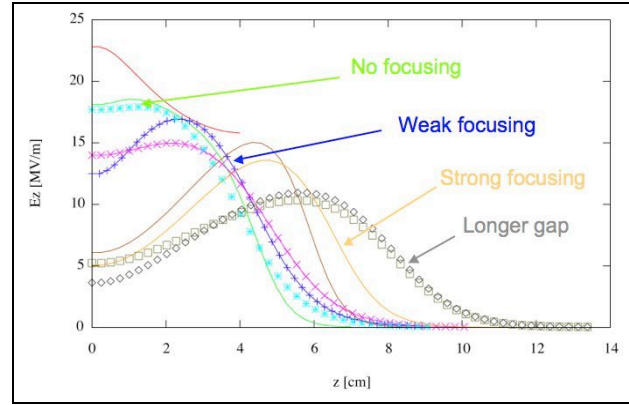

Figure 6: Accelerating field profile variation for 65MHz resonant frequency.

For each of the four cases considered, the initial beam parameters and beamline component properties (voltages, phases, peak solenoid fields) were re-optimized for minimum projected transverse emittance at the injector exit. The variation in slice average for the emittance along the bunch for the four cases is shown in Figure 7. For all cases, the optimized slice average for the emittance is $\sim 0.36\text{mm-mrad}$. For the beams under consideration here, the overall beam quality after longitudinal compression and emittance compensation is largely independent of the details of the gap geometry. A flat cathode with maximum accelerating gradient is thus favored over more complicated geometries.

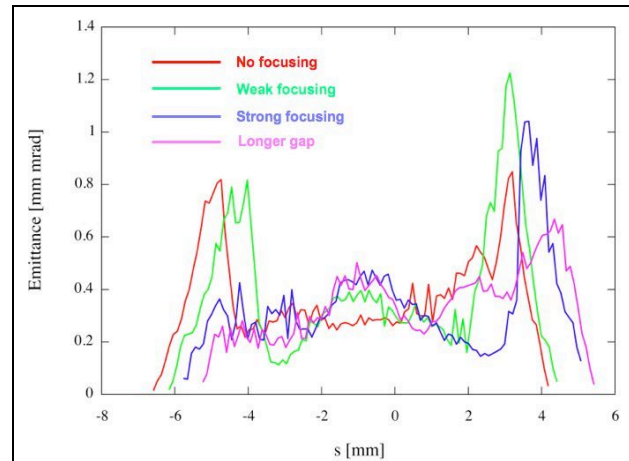

Figure 7: Variation of slice emittance for differing gap geometry. Bunch charge is 0.5nC .

Varying the resonant frequency

We have produced cavity designs with resonant frequency at 65MHz, 100MHz, 150MHz, and 200MHz.

In all cases, the accelerating gap region geometry has been kept constant with a 4cm gap holding off 750kV. However, the details of the remainder of the cavity have changed considerably with variations in frequency, in order to minimize stored energy and RF power requirements. Figure 8 shows the results of beam dynamics simulations with re-optimized beamlines and initial beam parameters for the cases with VHF guns with resonant frequency of 65MHz and 200MHz. Again, after compression and emittance compensation, the average of the bunch-averaged slice emittance is ~ 0.35 mm-mrad, independent of frequency in this band.

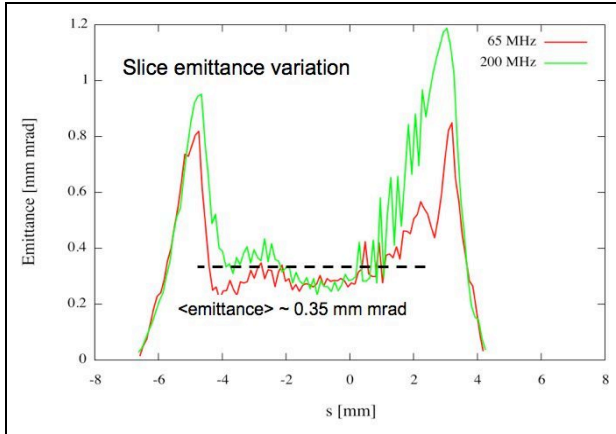

Figure 8: Slice emittance variation over the bunch with different cavity resonant frequencies.

Nearly optimized cavity geometry at 100 MHz

A resonant frequency of 100MHz has been initially chosen due to the availability of commercial broadcast industry tubes as RF power sources, ease of mechanical handling and vacuum maintenance, and creation of suitable accelerating gradients with reasonable amounts of stored energy. A candidate cavity geometry is shown in Figure 9. The field lines indicate the optimization process has moved away from a purely coaxial line resonator to a more reentrant pillbox resonator configuration. The cavity RF parameters are shown in Table 2.

REFERENCES

- [1] J. Corlett, *et. al.*, “A high repetition rate VUV-soft x-ray FEL concept”, Proceedings of the 2007 Particle Accelerator Conference, Albuquerque, June 2007.
- [2] P. Emma, *et. al.*, Phys. Rev. ST-AB, **9**, 100702 (2006).

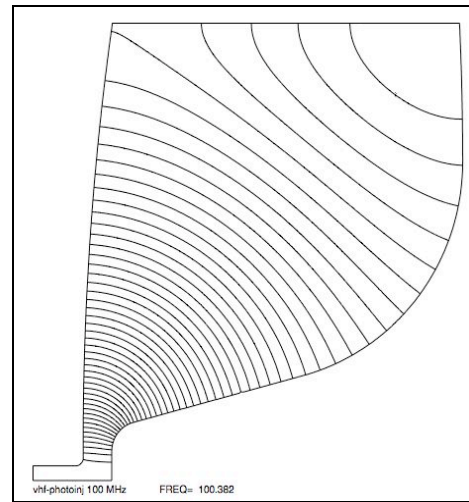

Figure 9: 100MHz cavity geometry.

Table 2: 100 MHz cavity design specifications.

Frequency	100.38	MHz
Q_0	37400	
$E_{\text{cath}}/E_{\text{max}}$	0.79	
Gap Voltage	750	kV
E_{cath}	17.7	MV/m
E_{max}	17.7	MV/m
H_{max}	7816	A/m
P_{total}	65.7	kW
$P_{\text{density, peak}}$	7.9	W/cm ²
Stored energy	3.9	J

CONCLUSIONS

We have presented a design for a high repetition rate RF photoinjector driven by a VHF band gun. This gun may present an attractive alternative to DC and SRF guns for some applications. We have demonstrated for bunch charges ~ 0.5 -1nC, that the beam dynamics and beamline optimization is largely unaffected by the RF gun frequency in the 50-200MHz band, and that final beam quality is also insensitive to the details of gap geometry.

- [3] J.-G. Marmouget, *et. al.*, “Present Performance of the Low-Emittance, High-Bunch Charge ELSA Photo-Injected LINAC”, Proceedings of EPAC 2002, Paris, France.
- [4] J. Staples, *et. al.*, “Design of a VHF-Band RF Photoinjector with Megahertz Beam Repetition Rate”, Proceedings of the 2007 Particle Accelerator Conference, Albuquerque.
- [5] http://www.desy.de/~mpyflo/Astra_dokumentation