

# UC Irvine

## UC Irvine Previously Published Works

### Title

Transposition of the yeast retroviruslike element Ty3 is dependent on the cell cycle.

### Permalink

<https://escholarship.org/uc/item/0rr7b0gp>

### Journal

Molecular and Cellular Biology, 14(12)

### ISSN

0270-7306

### Authors

Menees, TM  
Sandmeyer, SB

### Publication Date

1994-12-01

### DOI

10.1128/mcb.14.12.8229

### Copyright Information

This work is made available under the terms of a Creative Commons Attribution License, available at <https://creativecommons.org/licenses/by/4.0/>

Peer reviewed

## Transposition of the Yeast Retroviruslike Element Ty3 Is Dependent on the Cell Cycle

THOMAS M. MENEES AND SUZANNE B. SANDMEYER\*

*Department of Microbiology and Molecular Genetics, University of California,  
Irvine, Irvine, California 92717*

Received 1 April 1994/Returned for modification 26 May 1994/Accepted 28 August 1994

**Host cell cycle genes provide important functions to retroviruses and retroviruslike elements. To define some of these functions, the cell cycle dependence of transposition of the yeast retroviruslike element Ty3 was examined. Ty3 is unique among retroviruslike elements because of its integration, which occurs upstream of genes transcribed by RNA polymerase III. A physical assay for Ty3 transposition which takes advantage of this position-specific integration was developed. The assay uses PCR to amplify a product of Ty3 integration into a target plasmid that carries a modified tRNA gene. By using the *GALI* upstream activating sequence to regulate expression of Ty3, transposition was detected within one generation of cell growth after Ty3 transcription was initiated. This physical assay was used to show that Ty3 did not transpose when yeast cells were arrested in G<sub>1</sub> during treatment with the mating pheromone  $\alpha$ -factor. The restriction of transposition was not due to changes in transcription of either Ty3 or tRNA genes or to aspects of the mating pheromone response unrelated to cell cycle arrest. The block of the Ty3 life cycle was reversed when cells were released from G<sub>1</sub> arrest. Examination of Ty3 intermediates during G<sub>1</sub> arrest indicated that Ty3 viruslike particles were present but that reverse transcription of the Ty3 genomic RNA into double-stranded DNA had not occurred. In G<sub>1</sub>, the Ty3 life cycle is blocked after particle assembly but before the completion of reverse transcription.**

Retroviruses and long terminal repeat (LTR)-containing retrotransposons have similar structures and transposition cycles (58). The common steps of replication and integration for these elements, henceforth referred to collectively as retroviruslike elements, are (i) transcription of an integrated DNA copy of the element into RNA, (ii) translation of the RNA followed by assembly of particles composed of the RNA as well as the proteins encoded by the element, (iii) reverse transcription of the RNA into DNA, and (iv) integration of this DNA copy into the host cell genome. Retrotransposons are competent for transposition in the cell within which they reside, while retroviruses infect other cells.

Retroviruslike elements have genomes of between 2 and 8 kbp which include LTRs of a few hundred base pairs and code for both major structural proteins of the viral particles and enzymes necessary for transposition. The LTRs contain information for initiating transcription of the element and for terminating and processing transcripts. The genes of retroviruses are generally classified as *gag*, *pol*, and *env*. The *gag* gene products include the capsid protein (CA), which is the main structural component of the retroviruslike element particle; the nucleocapsid protein (NC), which binds the genomic RNA of the element; and, in some cases, the protease (PR), which processes the polyprotein translation products of *gag* and *pol*. In other retroviruses, PR is encoded by the *pol* gene. The other *pol* gene products are the reverse transcriptase (RT), which copies the genomic RNA into DNA, and the integrase (IN), which catalyzes insertion of this DNA into the host genome. Most LTR retrotransposons have open reading frames which encode proteins that perform functions similar to those of the *gag*- and *pol*-encoded proteins. Only retroviruses carry *env*

genes, which encode integral membrane proteins present in the extracellular, mature virus.

Retroviruslike elements depend on their hosts to propagate. Host cell cycle factors have been known to play a role in the retroviral life cycle since Rubin and Temin (49) reported that Rous sarcoma virus (RSV) does not productively infect non-dividing chicken embryo fibroblasts. Spleen necrosis virus (SNV) (54) and murine leukemia virus (MLV) (26) do not productively infect quiescent avian and mouse cells, respectively. Human immunodeficiency virus (HIV) does not infect quiescent human T lymphocytes (40) but does infect quiescent macrophages (18, 23). In cases in which productive infection of quiescent cells is impeded (16, 17, 22, 59, 62), reverse transcription of genomic RNA is deficient. Viral reverse transcriptases may require modification by cellular enzymes that are inactive in quiescent cells for DNA synthesis to proceed. Alternatively, substrates for reverse transcription may be limiting.

Restrictions of retroviral infections can also occur when proliferating host cells are arrested in their cell cycle. Experiments with synchronized cells suggest that MLV infection is blocked during G<sub>1</sub> (48) and also shows restriction in S (47, 48) and G<sub>2</sub> (48) phases. RSV cannot productively infect cells arrested in S phase (25). Reverse transcription of both MLV and RSV genomic RNAs occurs during these cell cycle arrests, but integration does not. MLV DNA is excluded from the nucleus until the cell has completed M phase (48), but for RSV it is not known how integration is affected.

In all the cases cited, a productive infection ensues once the host cell resumes division. Since different aspects of the retroviral life cycle are blocked in cells arrested at different points in the cell cycle, multiple retroviral processes are potentially affected by host cell cycle factors. Determining the nature of these examples of host cell dependency has been difficult by using retroviral systems because of the genetic intractability of the host cells.

\* Corresponding author. Phone: (714) 856-7571. Fax: (714) 856-8598. Electronic mail address: sbsandme@uci.edu.

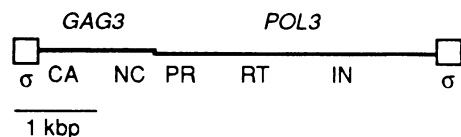

FIG. 1. Structure of the yeast Ty3 element. LTRs are designated by  $\sigma$ . The *GAG3* gene encodes the major structural proteins CA and NC. The *POL3* gene encodes the enzymes PR, RT, and IN.

Ty3, a retrotransposon found in the yeast *Saccharomyces cerevisiae*, belongs to a group of retroviruslike elements that are similar in structure to the *gypsy* element of *Drosophila melanogaster* (20). *S. cerevisiae* harbors four other types of retrotransposons (Ty1, Ty2, Ty4, and Ty5) that are similar to the *cop* element of *D. melanogaster* (6). Host cell cycle factors may play a role in Ty transposition since Ty1 does not transpose when yeast cells are arrested in G<sub>1</sub> with the mating pheromone  $\alpha$ -factor (60). However, unlike the retroviral examples cited above, Ty1 has not been shown to complete transposition once the host cell resumes division.

The entire Ty3 element (shown in Fig. 1) is 5.4 kbp long and has two open reading frames, *GAG3* and *POL3*, which are equivalent to the *gag* and *pol* genes, respectively, discussed above (14, 20, 21). Ty3 LTRs (called sigma elements) are 340 bp long. The *GAG3* gene products (and their apparent molecular masses) are CA (26 kDa) and NC (9 kDa); the *POL3* gene products are PR (16 kDa), RT (55 kDa), and IN (58 and 61 kDa). These gene products have been identified by immunoblot analysis, and NC, PR, RT, and IN are homologous and functionally equivalent to their retroviral counterparts (19, 21, 32). Ty3 transcription is low in haploid cells and is induced 20- to 50-fold with mating pheromones (4, 14, 57). Ty3 transcription is repressed by mating type regulation in nonmating diploid cells (4).

A high-copy-number plasmid carrying the *GAL1* upstream activating sequence (UAS) fused upstream of the presumed Ty3 TATA element provides a regulated system for studying Ty3 transposition (20). Yeast strains carrying this plasmid display elevated levels of transposition when grown on a galactose-containing medium. Viruslike particles (VLPs) equivalent to retroviral core particles can be isolated from these cells, and VLP fractions contain all of the distinguishable Ty3 components described above, including the genomic RNA and the double-stranded DNA (dsDNA) product of reverse transcription. VLPs have also been visualized in these cells by electron microscopy and immunofluorescence (19).

Unlike other retroviruslike elements, Ty3 manifests the striking property of integration specificity. In the genome, existing or de novo insertions of Ty3 have only been found upstream of tRNA genes (6, 10). Using a plasmid target assay, Chalker and Sandmeyer (11) have shown that Ty3 integrates near the transcriptional start sites of genes transcribed by RNA polymerase III (genes for tRNAs, U6 RNA, and 5S RNA). Because these integration sites are in the same position relative to the start site of transcription by RNA polymerase III and because mutations in promoter elements block transposition, it is hypothesized that the transcription complex itself is recognized by the integration factors.

Because of the structural relationship of Ty3 to animal retroviruses, it was of interest to determine whether Ty3 would resemble retroviruses with respect to cell cycle dependence of replication or integration. In this study we examined the relationship between Ty3 and host cell cycle factors by determining the effect of cell cycle arrest on Ty3 transposition. Cells

were arrested in G<sub>1</sub> with the yeast mating pheromone  $\alpha$ -factor because this arrest point has been well characterized (52) and a high efficiency of arrest can be achieved. Ty3 expression was regulated by the *GAL1* UAS, and Ty3 integration was assayed during cell cycle arrest by amplification of specific integration products by PCR (42).

## MATERIALS AND METHODS

**Strains, media, plasmids, and general procedures.** *Escherichia coli* HB101 was used in all plasmid amplifications and purifications. The *S. cerevisiae* strain used for these studies is yTM443 (*MATa ura3-52 trp1-H3 his3- $\Delta$ 200 ade2-101 lys2-1 leu1-12 can1-100 bar1::hisG* Ty3 null), which was created from yVB110 (*MATa ura3-52 trp1- $\Delta$ 901 his3- $\Delta$ 200 ade2-101 lys2-1 leu1-12 can1-100 gal3* Ty3 null) in several steps. The purpose of the modifications of yVB110 was to make a strain that was (i) sensitive to the yeast mating pheromone  $\alpha$ -factor for prolonged periods of time and (ii) rapidly inducible for galactose-regulated gene expression. Strain yTM444 (Gal<sup>+</sup> Trp<sup>+</sup>) was created by transforming yVB110 with pT1 (55) digested with *PvuII* and *SalI* and selecting for Trp<sup>+</sup> colonies. Plasmid pT1 carries a fragment of yeast genomic DNA containing *GAL3* and *TRP1*, which are near one another on chromosome IX. yTM441, a Trp<sup>-</sup> derivative of yTM444, was made in two steps. The yTM444 strain was transformed to Ura<sup>+</sup> with pL328 (30) digested with *XbaI*. Plasmid L328 carries a mutant *trp1* gene (*trp1-H3*, created by filling in the *HindIII* site in *TRP1*) as an 857-bp *EcoRI*-*BglII* fragment cloned into YIp5 (46), which carries *URA3* as a selectable marker. Transformants have the chromosomal and plasmid-borne copies of *TRP1* flanking YIp5 sequences at the *TRP1* locus. Derivatives of these transformants resistant to 5-fluoroorotic acid (5-FOA) (5) were screened for Trp<sup>-</sup> isolates. 5-FOA selects for loss of YIp5 sequences by selecting against the *URA3* gene. Loss of YIp5 sequences occurs primarily by recombination between the *TRP1* sequences, leaving behind one of the *TRP1* alleles (*TRP1* or *trp1-H3*). One isolate carrying *trp1-H3* was designated yTM441. A mutation was introduced into the *BARI* gene of yTM441 to increase its sensitivity to the yeast mating pheromone  $\alpha$ -factor. *BARI* encodes a protease which is secreted and degrades the mating pheromone in the surrounding medium, causing reduced responsiveness to pheromone-induced effects (39). The plasmid used to introduce the mutation, pTM47, was constructed from pZV9 (38), which contains a 2,750-bp *XbaI*-*XhoI* fragment encoding the *BARI* gene on pUC13. A 3.8-kbp *BamHI*-*BglII* fragment from pNKY51 (2) containing repeats of *hisG* from *Salmonella typhimurium* flanking the *URA3* gene from *S. cerevisiae* was ligated into the *BglII* site within the *BARI* gene of pZV9 to create pTM47. First, yTM441 was made Bar<sup>-</sup> by transformation to Ura<sup>+</sup> with an *XbaI* digest of pTM47. The yTM443 strain is a 5-FOA<sup>R</sup> derivative of one of these yTM441 transformants in which the *BARI* gene is interrupted with *Salmonella hisG*. The yTM446 strain is a *far1* derivative of yTM443 created by transforming yTM443 with a *NotI* digest of pFC13 (13).

A Ty3 element under control of the *GAL1* UAS is carried on pTM45, a low-copy-number (*ARS CEN*) plasmid marked genetically with *TRP1*. Plasmid pTM45 is similar to pJK311AC (33), except that instead of a *BamHI* site at position 296 of Ty3, as for pJK311AC, there is a *BamHI* site between the *GAL1* UAS and the partial sigma element at the 5' end of Ty3. Plasmid pKO211 (44), marked genetically with *URA3*, carries a Ty3-*lacZ* fusion under the control of the *GAL1* UAS and was used to monitor expression of the galactose-regulated Ty3. On pKO211 *lacZ* is fused in frame to *GAG3* and replaces most of

the *GAG3* and *POL3* sequences. Plasmid pDLC374 (11) (pDLC373 plus a *box4* promoter element) carries a modified allele of the tRNA<sup>Tyr</sup> gene *SUP2* and served as a target for Ty3 integration. Plasmid pDLC356 (11), similar to pDLC374 except that the tRNA<sup>Tyr</sup> gene is intact and a *Bst*EII site has been engineered into the intron sequences, was used for primer extension analysis of tRNA gene expression.

The synthetic complete medium has been described by Sherman et al. (50). SCR medium (synthetic complete raffinose), lacking the appropriate amino acids, contained 2% raffinose, 2% glycerol, and 3% lactic acid as carbon sources.

Cells were arrested in the G<sub>1</sub> stage of the cell cycle with  $\alpha$ -factor (G<sub>1</sub> arrest).  $\alpha$ -Factor (Sigma Chemical Co.) was used at a final concentration of 0.35  $\mu$ M. Arrest was monitored by microscopic examination. G<sub>1</sub> arrest induced by  $\alpha$ -factor is indicated by an accumulation of unbudded cells without and with projections (shmoos). With increased time of arrest, the percentage of shmoos rises.

**$\beta$ -Galactosidase assays.** Expression of Ty3 from a *GALI*-UAS-Ty3 promoter fusion was measured by  $\beta$ -galactosidase assays of extracts from cells carrying pKO211. Duplicate culture samples (10 ml each) were harvested by centrifugation, and the pellets were stored at  $-70^{\circ}\text{C}$ . The protein content of each sample was determined by the method of Bradford (7), and  $\beta$ -galactosidase assays were performed as described by Coney and Roeder (15).

**Physical assay for Ty3 transposition.** Liquid cultures of yTM443 transformed with the Ty3 plasmid pTM45 and the tRNA gene target plasmid pDLC374 were monitored for transposition by using a physical assay. Culture samples (10 ml) were harvested by centrifugation, and the pellets were stored at  $-70^{\circ}\text{C}$ . DNA was extracted by either the spheroplast or glass bead method (3, 50), and the DNA concentration was determined fluorometrically in the presence of the DNA-specific dye Hoechst 33258 (Calbiochem), using a Mini TKO 100 DNA Fluorometer (Hoefer Scientific Instruments). Between 5 and 25 ng of total yeast DNA was used in the PCRs described below.

Primers 278 and 279 were used in PCRs to amplify Ty3 integrants in pDLC374. Primer 278 is complementary to Ty3 nucleotides (nt) 444 to 418 on the plus strand and has the sequence 5'-CCTCCTGGGATTTGATCCATAAAGCTC-3'. The 5'-most 30 nt of primer 279 are complementary to the modified tRNA<sup>Tyr</sup> gene on plasmid pDLC374 at nt +25 to -5 on the plus strand, where position +1 corresponds to the major start site of transcription of this gene. The 3'-most 2 nt of primer 279 are complementary to Ty3 nt 1 and 2 on the minus strand. The sequence of primer 279 is 5'-CTTGGCTATGTTCTTATAATTAATATCAATG-3'. PCRs were set up with two different mixtures per reaction, one containing the primers and the other containing the cellular DNA and the *Taq* polymerase. In order to prevent mispriming, the two mixtures remained separated by a wax barrier (PCR Gem 100 wax beads; Perkin-Elmer) until the first denaturation step. All reactions were done in GeneAmp Thin-Walled Reaction Tubes (Perkin-Elmer). The 25- $\mu$ l lower mixture contained 1 $\times$  PCR buffer (50 mM KCl, 10 mM Tris-HCl, pH 8.3); 3 mM MgCl<sub>2</sub>; a 0.4 mM concentration of an equimolar mixture of dATP, dCTP, dGTP, and dTTP; and a 0.4  $\mu$ M concentration each of primers 278 and 279. This mixture was incubated for 10 min at 80 $^{\circ}\text{C}$  with a PCR Gem 100 wax bead and cooled to room temperature. The upper mixture was then placed on top of the solid wax surface covering the lower mixture. The 50- $\mu$ l upper mixture contained DNA in 1.25 $\times$  PCR buffer and 2.5 U of AmpliTaq DNA polymerase (Perkin-Elmer). PCR was carried out in a Perkin-Elmer DNA Thermal Cycler 480 following an

initial incubation at 95 $^{\circ}\text{C}$  for 2.5 min. Forty cycles, consisting of 45 s at 94 $^{\circ}\text{C}$ , 30 s at 55 $^{\circ}\text{C}$ , and 30 s at 72 $^{\circ}\text{C}$ , were run. Samples in which reactions were complete were stored at 4 $^{\circ}\text{C}$  until they were analyzed by polyacrylamide gel electrophoresis (PAGE) on 8% gels. PCR products were visualized by transillumination of gels with UV light after the DNA was stained with ethidium bromide.

Primers 284 and 285 (see Fig. 3) were used in PCR to amplify a region of the *HIS3* gene on pDLC374. Primer 284 is complementary to *HIS3* nt positions 961 to 980 of the GenBank sequence on the minus strand and has the sequence 5'-CAAAGGGAGAAAGTAGGAGA-3'. Primer 285 is complementary to *HIS3* nt positions 1200 to 1181 on the plus strand and has the sequence 5'-TTTAAATAATCGGTGTC ACT-3'. PCR was carried out as described above except that 20 cycles were run with primers 284 and 285.

**Primer extension.** The transcriptional activity of the tRNA gene present on pDLC356 (12) was measured indirectly by primer extension as described by Chalker and Sandmeyer (12). A <sup>32</sup>P-end-labeled oligonucleotide primer that anneals specifically to the intron of transcripts generated from the modified *sup2* tRNA gene on pDLC356 was used in the reaction mixtures. Primers bound to template RNAs (20  $\mu$ g per reaction mixture) were extended by reverse transcriptase (Life Sciences, Inc.). A DNA sequence ladder was also synthesized by using this primer and pDLC356 as a template and was visualized along with the primer extension reactions by electrophoresis in an 8% polyacrylamide (acrylamide-bisacrylamide, 20:1)-7 M urea gel and subsequent autoradiography.

**Antibodies.** Antibodies were raised against Ty3 CA and IN proteins and a peptide corresponding to a region of the Ty3 RT protein. The peptide, designated RT2, was designed from the RT domain of *POL3* (20, 32) and synthesized by Multiple Peptide Systems. The sequence of RT2 corresponds to Ty3-1 *POL3* deduced amino acid residues 322 to 336 (NH<sub>3</sub>-LQPY HVTEKNEQEINC-COOH). The carboxyl-terminal residue is not encoded by Ty3 but was used to couple the peptide to ovalbumin with the bifunctional reagent *m*-maleimidobenzoyl-*N*-hydroxysuccinimide ester (34, 36). Ty3 CA was isolated by preparation of Ty3 VLPs, sodium dodecyl sulfate (SDS)-PAGE, and excision of the 26-kDa band from the stained gel (24). Ty3 IN was expressed in *E. coli* and then isolated by SDS-PAGE (3) of cell extracts and excision of the 61-kDa band from the stained gel (24). The RT2 peptide and purified CA and IN were sent to the Berkeley Antibody Company for production of antibodies in rabbits. Sera from these rabbits were collected, and immunoglobulin G proteins were purified by affinity chromatography over *Staphylococcus aureus* protein A columns as described previously (19). Antiserum to the RT2 peptide was further purified by using the RT2 peptide linked to a column as described previously for other Ty3 antipeptide antisera (19). All preimmune and immune sera were tested on immunoblots to evaluate specificities of the sera for Ty3 proteins.

**Analysis of Ty3 VLP preparations and WCE.** Ty3 VLPs were prepared as described previously (19). Briefly, yTM443 transformants carrying pTM45 and pDLC374 were grown to early log phase as 1-liter cultures in SCR-His-Trp medium with vigorous shaking at 30 $^{\circ}\text{C}$ . For arrested cells,  $\alpha$ -factor was added and incubation was continued for 3 h until the cells were arrested (>99%) in G<sub>1</sub>, as determined by microscopic examination. Galactose was added to the cultures to a final concentration of 2% (after G<sub>1</sub> arrest for  $\alpha$ -factor-treated cultures), and incubation continued for 6 h. Cells were harvested by centrifugation, washed, and treated with Zymolyase for 30 min at 30 $^{\circ}\text{C}$ . Spheroplasts produced in this manner were harvested

by centrifugation, washed, and then broken open by being vortexed in the presence of glass beads. The cell debris was pelleted by centrifugation, and the extracts were loaded onto sucrose step gradients (70, 30, and 20% steps of 5, 5, and 16 ml, respectively). Gradients were centrifuged in a SW28 rotor at 25,000 rpm at 4°C for 3 h. The bottom 3.5 ml of the 30% step, containing the majority of the VLPs, was split into two portions. One portion was extracted with phenol-chloroform, and nucleic acids were precipitated with ethanol. The other portion was loaded over 20% sucrose and spun in a Ti50 rotor at 38,000 rpm at 4°C for 1 h to concentrate the VLP proteins, which were resuspended in 100  $\mu$ l of VLP buffer B (+Mg) (20). For cells arrested in G<sub>1</sub>,  $\alpha$ -factor was added to particle preparations up to the point of cell breakage. DNA (1  $\mu$ g) from VLPs was analyzed by Southern blot hybridization, using standard methods (3). Concentrated proteins from VLPs were fractionated by SDS-PAGE, transferred to nitrocellulose membranes (Hybond ECL, Amersham), and probed with antibodies to CA, IN, and the RT2 peptide. Secondary antibodies to rabbit immunoglobulin G were detected by the ECL system (Amersham).

Whole-cell extracts (WCEs) were prepared from 20-ml aliquots of cultures. Cells were harvested, washed with WCE buffer (2% Triton X-100, 1% SDS, 100 mM NaCl, 10 mM Tris-HCl [pH 8], 1 mM EDTA, 10% glycerol), and resuspended in 0.6 ml of WCE buffer containing 10  $\mu$ g of aprotinin per ml and 1 mM dithiothreitol. Suspensions were transferred to microcentrifuge tubes, 0.7 g of chilled glass beads was added to each tube, and the tubes were set on ice. Tubes were vortexed at maximum speed for 15 s and then plunged into ice for 15 s. This was repeated five times. After the liquid from each tube was transferred to a new tube, 0.4 ml of cold WCE buffer containing 10  $\mu$ g of aprotinin per ml and 1 mM dithiothreitol was added to each microcentrifuge tube containing the glass beads. These tubes were vortexed for 15 s, and the liquid was pooled with the corresponding first extraction liquid. The tubes containing the pooled extracts were spun for 5 min in a microcentrifuge, and the supernatants were transferred to new tubes and frozen at -70°C. The protein contents were determined by the bicinchoninic acid method (51) or the Bradford method (7). Twenty micrograms of protein per sample was analyzed by immunoblot as described for the VLP preparations.

## RESULTS

**Expression of Ty3 is regulated by the *GAL1* UAS.** A version of Ty3 that is regulated by the UAS of the yeast *GAL1* gene (29) was used so that expression of the Ty3 element could be controlled. A portion of the 5' LTR of Ty3 was replaced by the *GAL1* UAS (20). Transcription directed by the UAS is dependent on the presence of galactose and the absence of a repressing carbon source such as glucose (28). Transcription initiates and terminates in the upstream and downstream LTRs, respectively. An additional feature of the control of genes by the *GAL1* UAS is inhibition of transcription within minutes of glucose addition (1, 53).

Because the kinetics of Ty3 transposition were to be monitored over a relatively short time course, the Ty3 null strain yVB110 (4) was modified to allow rapid induction of transcription from the *GAL1*-Ty3 promoter fusion. The yVB110 strain carries the *trp1- $\Delta$ 901* allele, a deletion of the *TRP1* locus that includes two UAS elements from the upstream region of the adjacent gene, *GAL3*. The *GAL3* gene product is required for rapid transcriptional induction of genes necessary for utilization of galactose. Deletion of the two UAS elements decreases

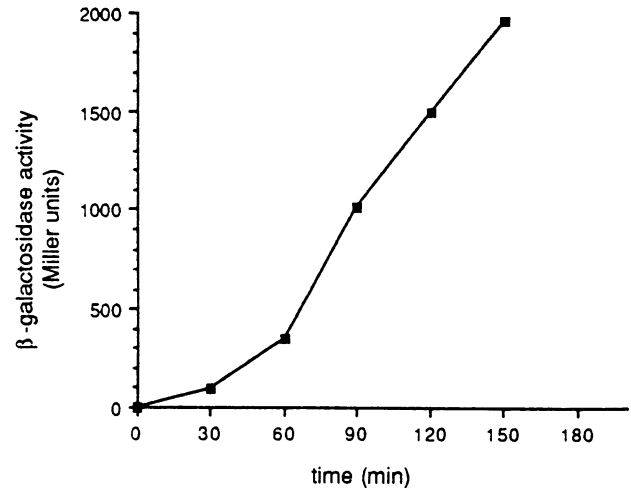

FIG. 2. Induction of Ty3 expression by galactose.  $\beta$ -Galactosidase activity was generated from a Ty3-*lacZ* fusion under the control of the *GAL1* UAS and was measured in samples of a yTM443 transformant carrying pKO211. Miller units are defined as nanomoles of *o*-nitrophenol formed per milligram of protein (41). Ten-milliliter samples were analyzed from a transformant grown in SCR-Ura (0 min) and at various times after galactose was added to 2% (30 to 150 min).

*GAL3* expression, allowing only long-term adaptation to galactose (55; reviewed in reference 27). Although *gal3* mutants are Gal<sup>+</sup>, rather than initiating a high level of expression of genes necessary for utilization of galactose within minutes of exposure to galactose, they require 24 to 48 h to achieve maximal expression.

Strain yTM443 was constructed from yVB110 (see Materials and Methods) and contains a wild-type *GAL3* gene. Expression of the Ty3 element under control of the *GAL1* UAS was measured in both yVB110 and yTM443 by measuring  $\beta$ -galactosidase activity generated from pKO211. This plasmid carries a Ty3 element, under control of the *GAL1* UAS, fused to the *E. coli lacZ* gene. yTM443 and yVB110 transformants containing pKO211 were grown in SCR medium (containing the nonrepressing, noninducing carbon source raffinose) lacking uracil to mid-log phase, and galactose was added to a final concentration of 2%. Immediately before the addition of galactose and at three 1-h intervals thereafter, two 10-ml samples were withdrawn. These samples were assayed for  $\beta$ -galactosidase activity as described in Materials and Methods. By 1 h after the addition of galactose to cells, 70-fold-more  $\beta$ -galactosidase activity was detected in yTM443 transformants than in yVB110 transformants (data not shown). After 24 h in galactose, yTM443 transformants still had 10-fold-higher  $\beta$ -galactosidase activity than yVB110 transformants. The induction of Ty3 expression following the addition of galactose to cells transformed with pKO211 is shown in Fig. 2. Within 1 h after the addition of galactose, a high level of  $\beta$ -galactosidase was detected, indicating that Ty3 expression was rapidly induced. The *GAL1* UAS allows the induction of naturally regulated genes within 8 min after the addition of galactose to medium containing a nonrepressing carbon source (1), and the Ty3 element used for these studies also appeared to be rapidly inducible.

**Ty3 transposition is detectable by PCR.** In order to detect Ty3 transposition during cell cycle arrest, a physical assay for transposition which takes advantage of the position specificity of Ty3 integration was designed. A plasmid carrying a modified tRNA gene (pDLC374) (11) served as a target for Ty3

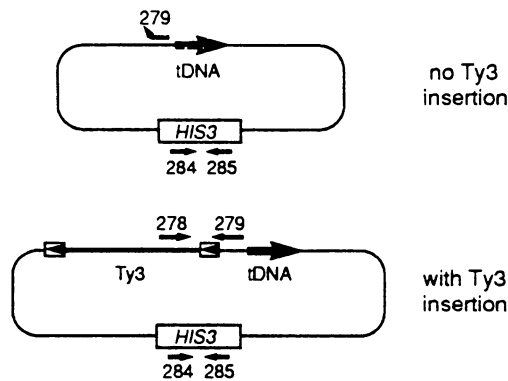

FIG. 3. Plasmids and primers for PCR assay of Ty3 transposition. pDLC374 is shown without and with a Ty3 insertion at the major start site for transcription of the tRNA gene (+1 position). The positions where the PCR primers anneal are indicated by arrows and the corresponding primer numbers.

integration (Fig. 3). A pair of primers (primers 278 and 279) was designed for use in PCR to amplify the product of Ty3 insertion at the -6 position relative to the major start site for transcription of this tRNA gene (+1 position) in the orientation in which Ty3 transcription is divergent to tRNA gene transcription. Chalker and Sandmeyer (11) have shown that this site is the target of the majority of Ty3 integration events in vivo. In the absence of Ty3 integration, only primer 279 anneals to the target plasmid. However, the two nucleotides at the 3' end of primer 279 are not complementary to the plasmid unless a Ty3 element is present at the -6 position and in the divergent orientation. Primer 278 hybridizes to the plasmid carrying the Ty3 element (pTM45) and to the target plasmid with a Ty3 insertion. The class of insertions described above can serve as a template for the formation of a 474-bp PCR product, which is diagnostic for Ty3 integration.

A second primer set (primers 284 and 285) was designed to amplify a 240-bp portion of the *HIS3* gene. This gene is the selectable marker on the target plasmid pDLC374. The yeast strain used in this study (yTM443) has a deletion of the chromosomal copy of the *HIS3* gene, so generation of this PCR product serves as an internal control for the amount of target plasmid in the DNA samples assayed for Ty3 insertions.

To determine whether this scheme worked, PCR was performed by using both primer sets separately on pDLC374 and a pDLC374 derivative, pTM42, containing an appropriate Ty3 insertion. As shown in Fig. 4, use of primers 278 and 279 resulted in a PCR product 474 bp in length from pTM42 but not pDLC374. Use of primers 284 and 285 resulted in a PCR product 240 bp in length from pTM42 and from pDLC374. The PCR was performed under conditions in which the amount of product was proportional to the amount of input plasmid.

To determine whether Ty3 transposition in vivo can be detected by using this assay, strain yTM443 transformed with the Ty3 plasmid pTM45 and the tRNA gene target plasmid pDLC374 was grown in SCR medium to early log phase ( $A_{600} = 0.2$ ), and galactose was added to a final concentration of 2% to induce transcription of the Ty3 element on pTM45. Ten-milliliter samples were removed from the culture immediately before and at five 1-h intervals after the addition of galactose. Following extraction of DNA, Ty3 integration and *HIS3* DNA levels were assayed by PCR as shown in Fig. 5. By 3 h after the addition of galactose, Ty3 integration into the tRNA gene target plasmid was detectable. The control, raffinose-grown

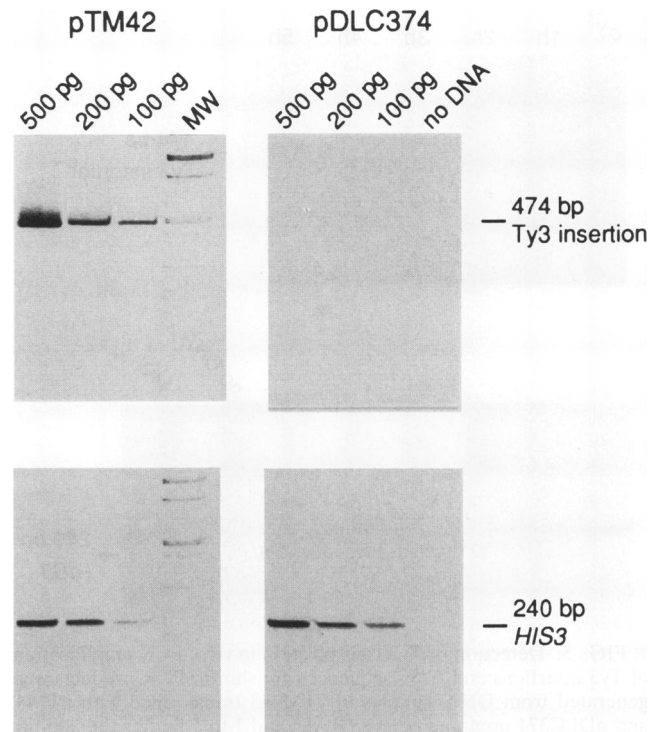

FIG. 4. PCR products from control assays of tDNA target plasmids. Ty3 insertions and *HIS3* sequences from pTM42, which contains a Ty3 insertion, and pDLC374, which does not contain a Ty3 insertion, are shown. The amounts of plasmid DNA used in the PCRs are indicated above each lane. Lanes marked "no DNA" represent control reactions (no template DNA); lanes marked "MW" represent molecular weight markers ( $\lambda$  DNA digested with *Pst*I). The indicated sizes of the PCR products generated from Ty3 insertions and *HIS3* sequences are 474 and 240 bp, respectively.

culture did not undergo Ty3 transposition. The *HIS3* PCR results showed that approximately equivalent amounts of DNA were used in all the assays. This and all subsequent PCRs were performed under conditions in which the amount of product was proportional to the amount of input plasmid.

**Ty3 does not transpose in cells arrested in  $G_1$  with  $\alpha$ -factor.** In order to assess the role of the host cell cycle in transposition, Ty3 transposition was measured in cells induced for Ty3 expression but arrested in  $G_1$ . yTM443 is a *bar1* mutant, so the cells are sensitive to lower amounts of  $\alpha$ -factor than are wild-type cells. Addition of 0.35  $\mu$ M  $\alpha$ -factor (versus 3.5  $\mu$ M for the wild type) results in  $G_1$  arrest (unbudded cells, as assessed by microscopic examination) in >99% of yTM443 cells after 3 h. A yTM443 transformant containing the Ty3 and tRNA gene plasmids was grown to early log phase in SCR medium lacking histidine and tryptophan. The culture was divided into two equal portions, and  $\alpha$ -factor was added to one portion at a final concentration of 0.35  $\mu$ M. After 3 h of shaking at 30°C, galactose was added to both portions at final concentrations of 2%, and incubation continued an additional 6 h. Samples were taken just prior to the addition of  $\alpha$ -factor, after the 3-h incubations with and without  $\alpha$ -factor, and from both portions treated with galactose for 6 h. DNA was prepared from the samples and used for PCR. As shown in Fig. 6A, Ty3 did not transposition in cells arrested in  $G_1$  with  $\alpha$ -factor.

**The effect of  $\alpha$ -factor treatment on Ty3 transposition is due to arrest of cells in  $G_1$ .** The mating pheromone response

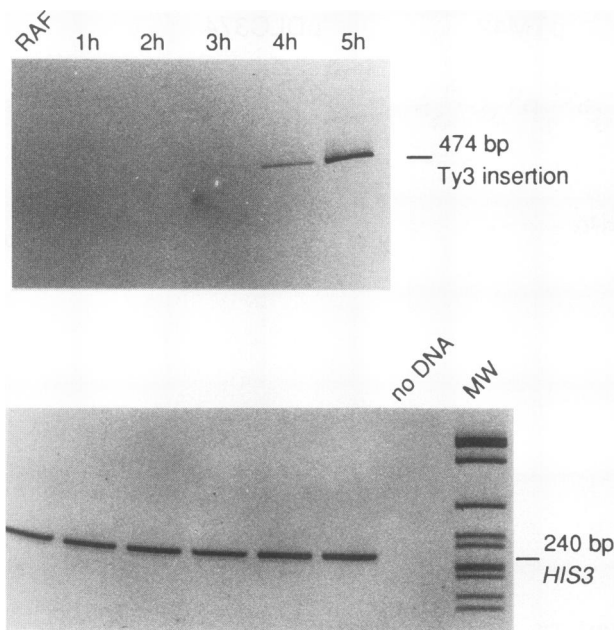

FIG. 5. Detection of Ty3 transposition in vivo. PCR amplifications of Ty3 insertions and *HIS3* sequences are shown. PCR products were generated from DNA samples of yTM443 transformed with pTM45 and pDLC374 prepared before (RAF) and 1 to 5 h after the addition of galactose to a SCR-His-Trp culture.

pathway elicited by  $\alpha$ -factor has two branches, one leading to cell cycle arrest in  $G_1$  and another leading to transcriptional activation of genes required for mating (Fig. 7). To determine whether the effect of  $\alpha$ -factor is due to  $G_1$  arrest or mating-type-specific transcriptional regulation, Ty3 transposition was measured during  $\alpha$ -factor treatment of a *far1* strain. *FAR1* acts in the  $G_1$  arrest branch of the mating pheromone response pathway (13). One of its functions is to inactivate the Cln2 protein, a  $G_1$ -specific cyclin which associates with the Cdc28 protein kinase that controls the  $G_1/S$  transition. The *far1* mutant does not arrest upon exposure to  $\alpha$ -factor, but the transcriptional regulation branch of the pheromone response pathway still functions. A transformant of yTM446, a *far1* derivative of yTM443, carrying the Ty3 and tRNA gene plasmids was grown to early log phase in SCR medium lacking histidine and tryptophan in parallel with the yTM443 transformant described in the preceding section. As for the yTM443 transformant, the culture of the yTM446 transformant was divided into two portions, and  $\alpha$ -factor was added to one portion at a final concentration of 0.35  $\mu$ M. After 3 h of shaking at 30°C, galactose was added to both portions at final concentrations of 2%, and incubation continued an additional 6 h. By microscopic examination after 3 h of  $\alpha$ -factor treatment, the yTM446 transformant displayed the phenotype characteristic of a *far1* mutant treated with  $\alpha$ -factor (13). Cells were elongated (shmoo), having formed projections associated with exposure to mating pheromone. However, unlike yTM443 transformants, yTM446 transformants continued to bud, indicating that cell cycle arrest had not occurred. As indicated in the preceding section, cell cycle arrest was determined to be >99% for the parallel culture of the yTM443 transformant after the 3-h incubation in  $\alpha$ -factor. Samples were taken just prior to the addition of  $\alpha$ -factor, after the 3-h incubations with and without  $\alpha$ -factor, and from both portions treated with galactose for 6 h. DNA was prepared from the

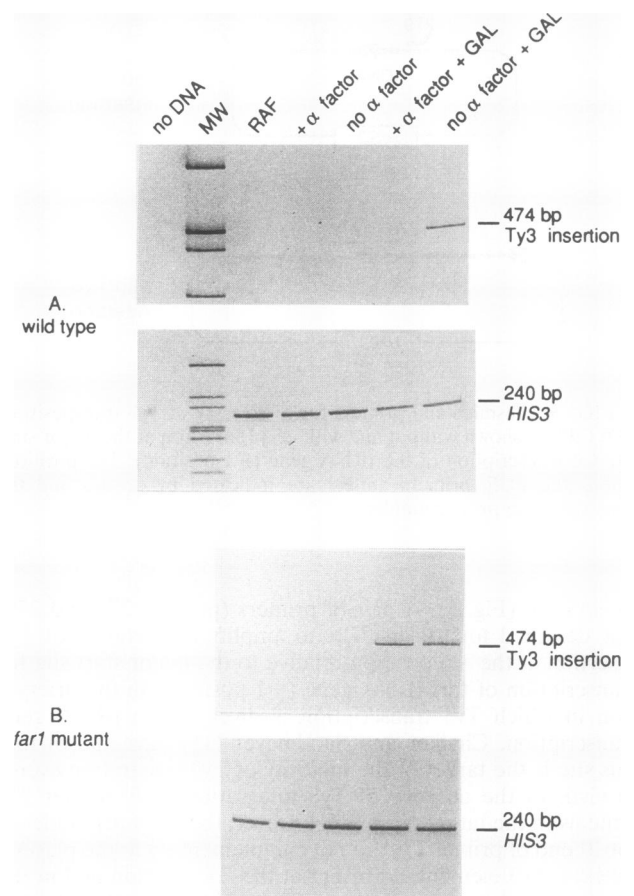

FIG. 6. Transposition of Ty3 in wild-type and *far1* mutant cells. (A) PCR products generated from DNA samples taken from yTM443 (wild type) transformed with pTM45 and pDLC374. Lanes: RAF, Ty3 insertions and *HIS3* sequences in cells taken from SCR-His-Trp cultures; + $\alpha$  factor, Ty3 insertions and *HIS3* sequences in cells taken after 3 h of  $\alpha$ -factor exposure; no  $\alpha$  factor, Ty3 insertions and *HIS3* sequences in cells taken from parallel cultures grown for 3 h without  $\alpha$ -factor; + $\alpha$  factor + GAL, Ty3 insertions and *HIS3* sequences in cells taken after 6 h of additional  $\alpha$ -factor exposure in 2% galactose; no  $\alpha$  factor + GAL, Ty3 insertions and *HIS3* sequences in cells taken after 6 h of exposure to 2% galactose without  $\alpha$ -factor. (B) Corresponding PCR products generated from DNA samples taken from yTM446 (*far1* mutant) transformed with pTM45 and pDLC374. Lanes: no DNA and MW (panel A only), control PCRs (no template DNA) for reactions presented in panels A and B and molecular weight markers ( $\lambda$  DNA digested with *Pst*I), respectively.

samples and used for PCR. As shown in Fig. 6B, Ty3 transposition occurred in the *far1* mutant treated with  $\alpha$ -factor at levels equivalent to those measured in both *far1* and wild-type cells not treated with  $\alpha$ -factor. These results indicate that it was the  $G_1$  arrest associated with  $\alpha$ -factor treatment that blocked Ty3 transposition in wild-type cells.

One possible reason that Ty3 transposition was restricted during  $G_1$  is that galactose-regulated Ty3 expression could have been low. To test this, a transformant of yTM443 carrying pKO211, a plasmid carrying a Ty3-*lacZ* fusion under control of the *GAL1* UAS, was grown in SCR medium lacking uracil to early log phase, and 0.35  $\mu$ M  $\alpha$ -factor was added. After 3 h of  $\alpha$ -factor treatment, cell cycle arrest was complete (>99% of cells in  $G_1$ ), as determined by microscopic examination. The culture was divided into three portions. The  $\alpha$ -factor was



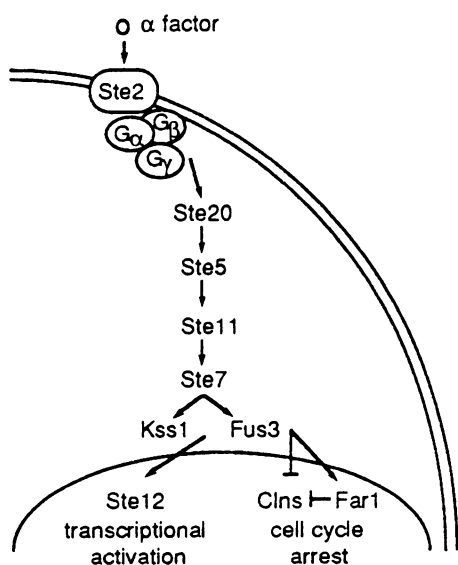

FIG. 7. Signal transduction elicited by mating pheromone in *MATa* cells. The curved double line represents the plasma membrane, which contains the  $\alpha$ -factor receptor (Ste2). The components of the heterotrimeric G protein ( $G_\alpha$ ,  $G_\beta$ , and  $G_\gamma$ ) which interact with the receptor are shown, as are the known components of the mitogen-activated protein kinase-like cascade (Ste20, Ste5, Ste11, Ste7, Kss1, and Fus3). The single curved line represents the nuclear envelope and shows the targets of the cascade (Ste12, Far1, and Clns), as well as the effects on the cell (transcriptional activation and cell cycle arrest).

removed from two of the portions. These two portions were resuspended in fresh SCR medium lacking uracil, and galactose was added to one of these portions to a final concentration of 2%, but not to the other. These cultures represented the positive and negative controls, respectively. Galactose was also added to the portion of the culture that still contained  $\alpha$ -factor. Samples were taken just before the addition of  $\alpha$ -factor, after the  $\alpha$ -factor incubation, and at 3-h intervals after treatment of the individual portions and were then analyzed for  $\beta$ -galactosidase activity. As shown in Fig. 8, the level of Ty3 expression was not affected by  $G_1$  arrest.

A second possible reason that Ty3 transposition was restricted during  $G_1$  is that transcription of the tRNA gene on the target plasmid could have been low. Chalker and Sandmeyer (11) have shown that the ability to bind transcription factors is required for a tRNA gene to serve as a target for Ty3 integration. The yTM443 strain transformed with pDLC356, a plasmid containing a marked tRNA<sup>Tyr</sup> gene, was grown to early log phase in SCR medium lacking histidine. The culture was divided into two portions. One portion was left untreated while the other portion was treated with  $\alpha$ -factor (0.35  $\mu$ M) to block the cell cycle. After 3 h of exposure to  $\alpha$ -factor, cell cycle arrest was complete (>99%) as determined by microscopic examination. After an additional 3 h at 30°C with shaking, samples (10 ml) were withdrawn from the cycling and arrested cultures, total RNA was extracted, and primer extension analysis was performed with a primer which anneals to the intron of the pre-tRNA<sup>Tyr</sup> expressed from pDLC356. The primer extension analysis detects two forms of the transient, unspliced pre-tRNA (forms with unprocessed and processed 5' ends) and provides an estimate of the transcription level at the sampling time. As shown in Fig. 9, the level of pre-tRNA during  $\alpha$ -factor arrest is not dramatically different from the level observed for cycling cells. This indicates that tRNA genes

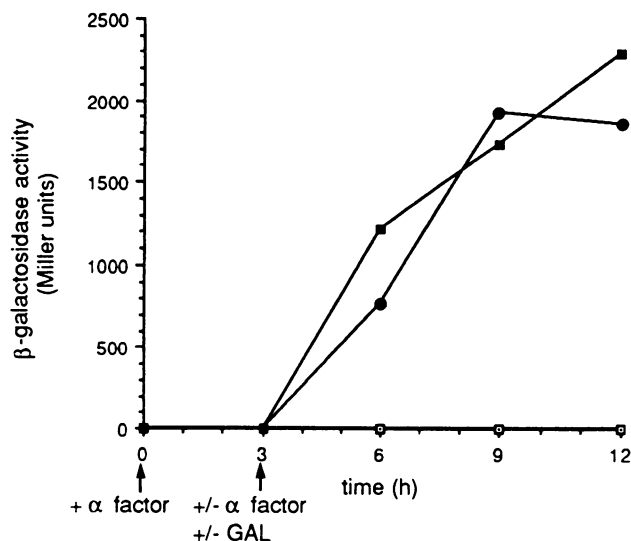

FIG. 8. Expression of Ty3 during  $G_1$  arrest.  $\beta$ -Galactosidase activity was generated from a Ty3-*lacZ* fusion under the control of the *GAL1* UAS. yTM443 transformed with pKO211 was treated with  $\alpha$ -factor (+ $\alpha$  factor) for 3 h to induce cell cycle arrest. Arrest was either maintained (solid squares) or not (solid circles and open squares). Following the initial 3 h of  $\alpha$ -factor treatment, galactose was added to 2% to the arrested culture (solid squares) and one of the cultures released from arrest (solid circles). The culture to which galactose was not added served as a negative control (open squares). Ten-milliliter samples were taken at the times indicated (0, 3, 6, 9, and 12 h) and used to assay  $\beta$ -galactosidase activity. The points show a representative set of samples.

are competent to serve as targets for Ty3 integration during  $G_1$  arrest.

**Ty3 intermediates formed during  $G_1$  arrest are able to complete transposition upon the removal of  $\alpha$ -factor.** The reversibility of the mating-pheromone-induced block of Ty3 transposition was investigated to determine the relationship of the Ty3 block to the block of retroviral infections in nondividing animal cells and to probe the relationship between the natural pheromone induction of Ty3 transcription and transposition. A yTM443 transformant containing the Ty3 and tRNA gene plasmids was grown to early log phase in SCR medium lacking histidine and tryptophan. After cells were arrested in  $G_1$  following treatment with  $\alpha$ -factor for 3 h, the culture was divided into three portions. In two portions, cells were collected by centrifugation and washed twice with water to remove the  $\alpha$ -factor. These two portions were resuspended in fresh SCR medium lacking histidine and tryptophan to allow resumption of cell division. Galactose was added to one of these portions to a final concentration of 2% to induce transcription of Ty3. These portions of the original culture were reincubated at 30°C with shaking and served as negative (no GAL) and positive (+GAL) controls for Ty3 transposition.  $\alpha$ -Factor was left in the third portion of the culture to maintain  $G_1$  arrest, and Ty3 transcription was induced by the addition of galactose to a final concentration of 2% (+ $\alpha$ -factor +GAL). Samples (20 ml) were taken from each portion after 6 h of further incubation at 30°C with shaking. Transcription of Ty3 was then repressed in the + $\alpha$ -factor +GAL portion by the addition of glucose to a final concentration of 2%. After 30 min, galactose and  $\alpha$ -factor were removed from this portion to maintain tight repression of Ty3 transcription and also to release cells from  $G_1$  arrest. Cells were harvested by centrifu-



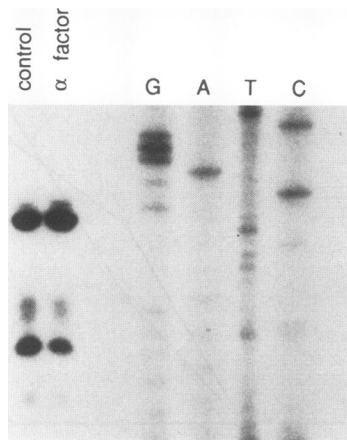

FIG. 9. Transcription of tRNA genes in cycling and arrested cells. SCR-His-Trp cultures of yTM443 transformed with pDLC356 were arrested in  $G_1$  or allowed to continue cycling.  $^{32}\text{P}$ -labeled primer extension products (generated from 20  $\mu\text{g}$  of total RNA for each sample) represent transcripts of the modified *SUP2* gene on pDLC356 from cells arrested in  $G_1$  with  $\alpha$ -factor and in cycling cells (control). The larger primer extension products represent transcripts unprocessed at the 5' end, while the smaller products represent processed transcripts. A sequence ladder (lanes G, A, T, and C) was generated from pDLC356 DNA with the same primer used for the primer extension reactions to show the positions of the transcripts on the DNA template.

gation, washed twice in SCR medium containing 2% glucose, and resuspended in SCR medium containing 2% glucose. Samples were taken 1.5 and 3 h after incubation in glucose-containing medium at 30°C with shaking. DNA was extracted from all the samples and quantitated. Ty3 transposition was assayed by PCR with 25 ng of total DNA. As shown in Fig. 10A, Ty3 transposition did not occur during  $G_1$  arrest (+ $\alpha$ -factor +GAL) but did occur by 1.5 h after the removal of  $\alpha$ -factor from the medium. This transposition occurred in the absence of new Ty3 transcription but with faster kinetics (1.5 versus 3 to 4 h) than seen following new transcription. This pattern is consistent with the existence of a Ty3 transposition intermediate formed during  $G_1$  arrest that completes transposition once  $G_1$  arrest is alleviated. The Ty3 block is similar to blocks of retroviral infections in nondividing cells, which are also reversible once those cells are stimulated to divide. In addition, reversibility of the  $G_1$  block indicates how transposition can occur under physiological conditions following the induction of Ty3 transcription by mating pheromones.

**Ty3 VLPs with unreplicated DNA accumulate during  $G_1$  arrest.** WCEs and VLP preparations from cells in  $G_1$  arrest and after release from arrest were analyzed for Ty3 proteins and DNA. WCEs were prepared from yTM443 transformants expressing Ty3 during  $G_1$  arrest and 1.5 and 3 h after release from arrest in the absence of Ty3 transcription, as described above. Immunoblot analysis, probing for Ty3 major structural proteins encoded by *GAG3*, was carried out. *GAG3*-encoded proteins, including the 26-kDa mature CA, were detected in cells arrested in  $G_1$  (Fig. 10B). The additional species were not reproducibly detected and may be degradation products. By analogy to retroviruses (37), processing of Ty3 proteins is believed to occur when they are associated in a VLP. If this assumption is correct, these data indicate that Ty3 VLPs formed during  $G_1$  arrest.

Samples of DNA from WCEs which were duplicates of those used in the PCRs described above were analyzed by Southern

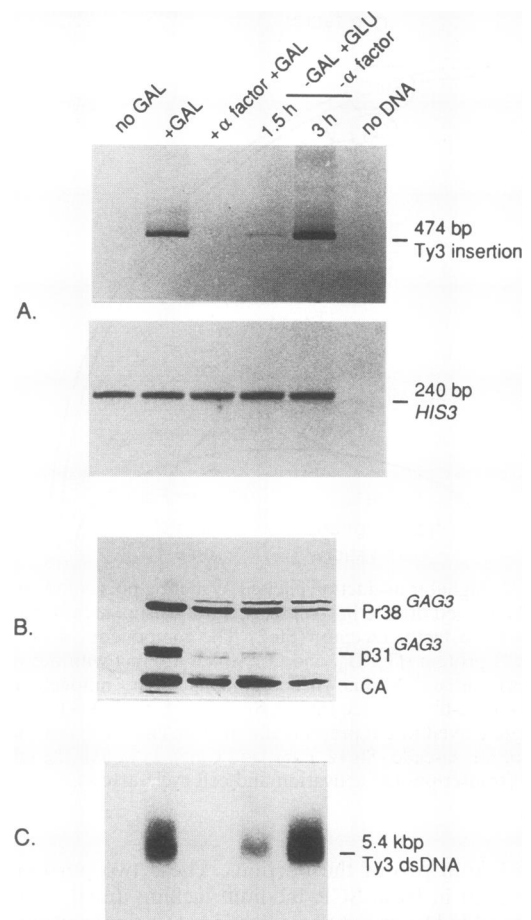

FIG. 10. Effects of  $G_1$  arrest on Ty3. (A) PCR products generated from DNA samples prepared from yTM443 transformed with pTM45 and pDLC374. Lanes: no GAL, Ty3 insertions and *HIS3* sequences in cells treated with  $\alpha$ -factor for 3 h to arrest cells in  $G_1$ , washed to remove  $\alpha$ -factor, and incubated in SCR-His-Trp for 6 h; +GAL, Ty3 insertions and *HIS3* sequences in cells arrested as described above but transferred to medium containing 2% galactose for 6 h; + $\alpha$  factor +GAL, Ty3 insertions and *HIS3* sequences in cells arrested for 9 h but incubated in medium containing 2% galactose after the first 3 h; 1.5 h and 3 h (which are both -Gal, +Glu, and - $\alpha$ -factor), Ty3 insertions and *HIS3* sequences in cells described for lanes + $\alpha$  factor +GAL at 1.5 and 3 h, respectively, after glucose was added and galactose and  $\alpha$ -factor were removed. (A) Lanes marked "no DNA" represent control PCRs (no template DNA). Sizes of the PCR products and their identities are indicated at the right. (B) Immunoblot of WCEs prepared from the same cultures as in panel A probed with anti-CA antibodies. The Pr38<sup>GAG3</sup> protein is the 38-kDa primary translation product of *GAG3* and is the precursor to CA and NC, the p31<sup>GAG3</sup> protein is a 31-kDa *GAG3* gene product that is proteolytically processed from a larger precursor, and CA is the 26-kDa mature capsid protein. (C) Southern blot of DNA samples equivalent to those used for the PCRs shown in panel A hybridized with a probe for Ty3 DNA. As indicated, the size of full-length Ty3 dsDNA is 5.4 kbp.

blot to test for the presence of the 5.4-kbp dsDNA reverse transcription product of Ty3 replication. Ty3 dsDNA was present at a very low level when Ty3 was expressed during  $G_1$  arrest compared with the level in cycling cells (Fig. 10C). WCEs were also analyzed for the presence of Ty3 DNA and proteins following the release of cells from  $G_1$  arrest. Within 1.5 h after  $\alpha$ -factor removal, Ty3 dsDNA was detectable, and by 3 h the level reached that found in cycling cells (Fig. 10C).

In this experiment, Ty3 transposition was detectable by PCR 1.5 h after the release of cells from G<sub>1</sub> arrest (Fig. 10A). Thus, full-length Ty3 DNA was not detectable during the arrest, but the genomic DNA accumulated in cells after the block to transposition was removed.

Particle assembly is a distinctive stage of the Ty3 life cycle. Since VLP preparations constitute a particulate fraction of the cellular contents, the presence of Ty3 components in such preparations can be used as a measure of particle assembly. VLP preparations were made to confirm that VLPs did form when Ty3 was expressed during G<sub>1</sub> arrest and to examine Ty3 proteins within the VLPs. For VLP preparations, three separate 1-liter cultures of yTM443 transformed with pTM45 and pDLC374 were grown to early log phase in SCR medium lacking histidine and tryptophan. The  $\alpha$ -factor was added to one culture at a final concentration of 0.35  $\mu$ M and culture incubation continued for 3 h, at which point cell cycle arrest (>99%) was confirmed by microscopic examination. Galactose was added at a final concentration of 2% to this culture and to one of the cultures not treated with  $\alpha$ -factor to induce transcription of Ty3. After 6 h of further incubation at 30°C with shaking, the cultures were harvested and VLPs were prepared as described in Materials and Methods. VLP preparations from uninduced cells and from induced cells arrested or not arrested with  $\alpha$ -factor were analyzed for the presence of Ty3 proteins by immunoblots, using antibodies to Ty3 CA, RT, and IN proteins. Proteins encoded by *GAG3* and *POL3* were detected in VLP preparations from cells arrested in G<sub>1</sub> (Fig. 11A). The level of Ty3 proteins recovered from arrested cells was reduced compared with the level recovered from cycling cells. Determination of whether this decrease was actually due to increased turnover of Ty3 proteins during arrest was complicated by the variability of recovery of VLP proteins in treated compared with untreated cells. In addition, VLP preparations were analyzed for the presence of Ty3 dsDNA by Southern blot hybridization. Ty3 dsDNA was undetectable in VLP preparations from cells arrested in G<sub>1</sub> (Fig. 11B). Thus, in G<sub>1</sub>, the Ty3 life cycle is blocked after particle assembly but before the completion of reverse transcription.

## DISCUSSION

To study the effect of cell cycle arrest on Ty3 transposition it was necessary to (i) efficiently arrest cells at a particular point in the cell cycle, (ii) control expression of the Ty3 element so that it could be activated during cell cycle arrest, and (iii) assay Ty3 transposition during cell cycle arrest. The yeast mating pheromone  $\alpha$ -factor was used because cell cycle arrest can be achieved with a high degree of efficiency. Small amounts of pheromone induce and maintain G<sub>1</sub> arrest in >99% of *bar1* mutant cells in culture. Furthermore, the role of  $\alpha$ -factor in cell cycle arrest and other processes is well characterized (for a review, see reference 52), and the  $\alpha$ -factor signal transduction cascade is the natural mechanism of induction of Ty3 transcription and transposition. Many components of the signal transduction pathway elicited by  $\alpha$ -factor have been identified. Activation of signal transduction begins when  $\alpha$ -factor interacts with a cell surface receptor that is coupled to a cytoplasmic, heterotrimeric G protein. Activation causes the G <sub>$\alpha$</sub>  subunit of the G protein to separate from the G <sub>$\beta$</sub>  and G <sub>$\gamma$</sub>  subunits, which activate a serine/threonine protein kinase cascade similar to the mammalian mitogen-activated protein kinase cascade activated in response to growth factors. The cascade results in two genetically separable processes: transcriptional activation of mating-type-specific genes and cell cycle arrest in G<sub>1</sub>. G<sub>1</sub> arrest results from inhibition of the G<sub>1</sub>

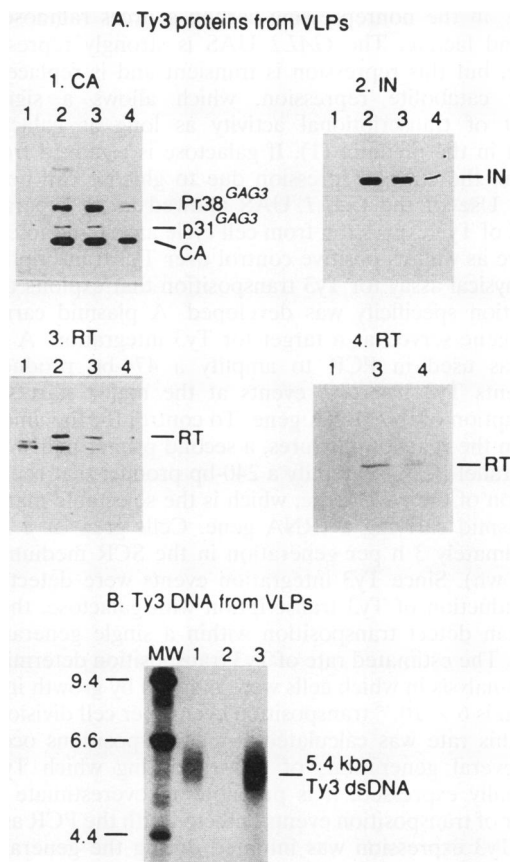

FIG. 11. Composition of Ty3 VLPs formed during G<sub>1</sub> arrest. Ty3 proteins and DNA were from VLP preparations of arrested and cycling yTM443 cells transformed with pTM45 and pDLC374. (A) Western blots (immunoblots) probed with antibodies to CA, IN, and RT. Lanes 1, sample taken from cycling cells growing in SCR-His-Trp; lanes 2 and 3, samples taken from two different cultures of cycling cells growing in SCR-His-Trp that were incubated in 2% galactose for 6 h; lane 4, sample taken from cells arrested with  $\alpha$ -factor for 3 h and then incubated in 2% galactose for 6 h. The sizes of CA, IN, and RT are 26, 61 and 58, and 55 kDa, respectively. The sizes of the other two *GAG3* gene products are 38 and 31 kDa, as indicated by their names. Western blot 4 contains 0.25  $\mu$ g of VLP protein in each lane; Western blot 1 contains 0.25  $\mu$ g of VLP protein in lanes 1 and 3 and 1.25  $\mu$ g of VLP protein in lane 4. (B) Southern blot of DNA samples hybridized with a probe for Ty3 DNA. Lane 1, DNA sample from cycling cells incubated in 2% galactose for 6 h; lane 2, DNA sample from cells arrested with  $\alpha$ -factor for 3 h and then incubated in 2% galactose for 6 h; lane 3, positive control for Ty3 full-length dsDNA. Each lane contains 1  $\mu$ g of nucleic acid. Size markers are  $\lambda$  DNA digested with *Hind*III and are in kilobase pairs. The size of full-length Ty3 dsDNA is 5.4 kbp and is indicated at the right.

cyclins that are essential components of the Cdc28 protein kinase important for the G<sub>1</sub>/S transition. Transcription from the Ty3 promoter present in the LTR is induced 20- to 50-fold by yeast mating pheromones. Since Ty3 expression is greatest during exposure to mating pheromones, the cell cycle arrest they induce is of direct relevance to the Ty3 life cycle.

Transcription of the Ty3 element used in these experiments was under the control of the *GAL1* UAS. All chromosomal copies of the Ty3 element had been deleted in the yeast strain used for these studies so that no Ty3 expression occurs in the absence of galactose induction. Expression of the Ty3 element was induced rapidly by the addition of galactose to cells

growing in the nonrepressing carbon sources raffinose, glycerol, and lactate. The *GAL1* UAS is strongly repressed by glucose, but this repression is transient and is replaced by a weaker catabolite repression, which allows a significant amount of transcriptional activity as long as galactose is present in the medium (1). If galactose is removed from the medium, the strong repression due to glucose can be maintained. Use of the *GAL1* UAS allowed us to separate the control of Ty3 expression from cell cycle arrest and to exercise negative as well as positive control over Ty3 transcription.

A physical assay for Ty3 transposition that exploits the Ty3 integration specificity was developed. A plasmid carrying a tRNA gene served as a target for Ty3 integration. A primer pair was used in PCR to amplify a 474-bp product that represents Ty3 insertion events at the major start site for transcription of this tRNA gene. To control for the amount of DNA in the reaction mixtures, a second primer pair was used in a parallel PCR to amplify a 240-bp product that represents a portion of the *HIS3* gene, which is the selectable marker on the plasmid carrying a tRNA gene. Cells grew at a rate of approximately 3 h per generation in the SCR medium (data not shown). Since Ty3 integration events were detected 3 h after induction of Ty3 transcription with galactose, the PCR assay can detect transposition within a single generation of growth. The estimated rate of Ty3 transposition determined by a  $P(0)$  analysis in which cells were induced by growth in liquid medium is  $6 \times 10^{-3}$  transposition events per cell division (31). Since this rate was calculated from transpositions occurring over several generations of growth during which Ty3 was continually expressed, it is probably an overestimate of the number of transposition events detected with the PCR assay, in which Ty3 expression was initiated during the generation in which transposition was measured.

Ty3 did not transpose when cells were arrested in  $G_1$  with  $\alpha$ -factor. Restriction of Ty3 transposition was not due to reduced transcription of Ty3 during  $G_1$ , because expression of a Ty3-*lacZ* fusion was similar in arrested and cycling cells. Nor was restriction of Ty3 transposition due to reduced transcription of tRNA genes, because primer extension of a transient pre-tRNA indicated that similar levels of this transcript were present in arrested and cycling cells. Since the mating pheromone response pathway leads to both cell cycle arrest in  $G_1$  and transcription of mating-type-specific genes, it was necessary to distinguish which effect caused restriction of Ty3 transposition. *FAR1* (13) acts in the  $G_1$  arrest branch of the mating pheromone response pathway since *far1* mutants do not arrest upon exposure to  $\alpha$ -factor but still undergo mating-specific transcriptional activation. Since Ty3 transposition occurred in a *far1* mutant treated with  $\alpha$ -factor, the restriction of transposition observed in wild-type cells must be due to cell cycle arrest.

Ty3 intermediates formed during  $G_1$  completed transposition when cells were released from  $\alpha$ -factor arrest. VLPs were present during  $G_1$  arrest, but they did not contain Ty3 dsDNA. The reversibility of the block in Ty3 DNA synthesis argues strongly (albeit indirectly) for the presence of Ty3 genomic RNA in VLPs during  $G_1$  arrest. Furthermore, the rapid kinetics of Ty3 DNA synthesis and transposition following release of cells from  $G_1$  arrest suggest that preformed rather than newly made particles are involved in these events. Direct assessment of particle-associated RNA is difficult for Ty3 in that no method that allows one to clearly distinguish RNA that is specifically packaged from RNA that is nonspecifically associated with VLPs has been developed (45). Thus, in  $G_1$ , the Ty3 life cycle appears to be blocked at the stage after particle assembly and before the completion of reverse tran-

scription. The block may have one of three causes: (i) modification of the RT enzyme or some other component of Ty3 VLPs may be necessary to proceed, (ii) a particular subcellular localization of VLPs may be necessary to proceed, or (iii) substrates for reverse transcription may not be available in sufficient quantities during  $G_1$ . An activator or repressor of protein modification could be cell cycle regulated, although preliminary experiments have not demonstrated differences in modification of Ty3 proteins (e.g., phosphorylation) during  $G_1$  arrest (data not shown). Alternatively, a change in particle localization might not occur during  $G_1$  arrest. This could either block particle modification or keep the RT enzyme from substrates necessary for reverse transcription. There are several examples of nuclear protein localization being regulated by cell cycle factors (43, 61). In addition, nuclear transport of DNA or particles must occur in the Ty3 life cycle, since the nuclear envelope does not break down during the yeast cell cycle. Determination of Ty3 RT activity *in vitro*, using VLPs isolated from cells arrested in  $G_1$  with  $\alpha$ -factor, will distinguish among some of these possibilities. VLP proteins appear to be less efficiently recovered from WCEs of  $G_1$  cells than from cycling cells, suggesting that VLPs present during  $G_1$  arrest may have an altered structure or be sequestered at a particular cellular location, alternatives which are consistent with the first two hypotheses above. In addition, turnover of VLPs may occur at an elevated rate during  $G_1$  arrest.

Transposition of the yeast Ty1 retrotransposon is greatly diminished by treatment of cells with mating pheromones (60). As for Ty3, VLPs form, but reverse transcription does not occur. Genetic assays of transposition of Ty1 elements induced during  $\alpha$ -factor arrest failed to detect transposition at levels similar to those observed in control cells, and biochemical assays reflected decreased levels of intermediates in arrested cells. It is not clear, however, how much of the transposition seen in treated cells occurred during pheromone treatment and how much occurred (by transposition of intermediates) following the removal of pheromone. Thus, whether the transposition block observed for Ty1, which did not appear to be reversible, is comparable to the block observed in our experiments cannot be determined from those data.

Infections by many retroviruses are blocked by arresting the host cell cycle. The results presented for Ty3 in  $G_1$  are similar to those for RSV, SNV, MLV, and HIV in  $G_0$ : in all cases reverse transcription is deficient. When cells resume division, Ty3 and these retroviruses resume their life cycles. For HIV, reverse transcription actually initiates in quiescent T cells but only reaches completion when those cells are stimulated to divide. We have not yet determined whether Ty3 initiates reverse transcription during  $G_1$  arrest.

Differences do exist, however, among retroviruses with respect to their abilities to infect cells in different stages of the division cycle. The oncogenic retroviruses mentioned above (e.g., MLV, RSV, and SNV) appear to require host cell division in order to establish a productive infection. For MLV, passage of the host cell through mitosis is required for integration of the viral DNA into the host's genome (48). It is believed that breakdown of the nuclear envelope is necessary for the viral integration complex to gain access to the nucleus. Lentiviruses (e.g., HIV and Visna virus), on the other hand, have the ability to infect different types of nondividing cells (8, 9, 18, 23, 35, 56). Although HIV is unable to establish a productive infection of quiescent T cells, this virus is able to infect terminally differentiated macrophages (18, 23) and CD4<sup>+</sup> HeLa cells arrested in  $G_2$  (35), as well as T cells arrested at the  $G_1/S$  boundary (8, 9). A nuclear localization signal in the HIV matrix protein allows uptake of preintegration complexes

into the nuclei of some cells, which is required for HIV infection of cells not in M phase (9). HIV preintegration complexes are not taken up by the nuclei of quiescent T cells (9), which may be missing a transport factor. As mentioned above, nuclear entry is a requirement for integration of Ty3 DNA, and our results could be explained by a nuclear transport deficiency during G<sub>1</sub> arrest if DNA synthesis is coupled to transport. The nuclear localization signal for the Ty3 preintegration complex as well as the composition of the complex is unknown.

Yeast mating pheromones increase the activity of the native Ty3 promoter contained within the sigma element 20- to 50-fold. Kinsey and Sandmeyer (31) have shown that the amount of Ty3 transcription that occurs during a yeast mating reaction is sufficient to result in transposition. In order to reconcile those results with the restriction of Ty3 transposition we observed during G<sub>1</sub> arrest, we propose that during a mating reaction, Ty3 VLPs form but do not undergo DNA synthesis. Once a zygote is formed and exits G<sub>1</sub>, these particles complete the Ty3 life cycle. Therefore, although high levels of Ty3 transcription occur only during a particular phase of the yeast life cycle (the mating reaction), there is a further restriction on the transposition process for this element. This model is consistent with the observation of Kinsey and Sandmeyer (31) that a target plasmid present in cells of one mating type could be used by Ty3 which is expressed in cells of the opposite mating type during the mating reaction. It is also consistent with the apparent reversibility observed in our experiments.

Identification of points in the cell cycle when transposition does not occur, coupled with the tractability of *S. cerevisiae* as an experimental organism, will allow a thorough analysis of the blockage and, eventually, identification of the cellular factors involved. Our next step is to identify factors that are involved in this cell cycle regulation of Ty3 transposition by isolating cellular genes that are able to override the block of the Ty3 life cycle during G<sub>1</sub> arrest. Analysis of these genes, combined with more detailed knowledge of the Ty3 intermediate present during G<sub>1</sub> arrest, will allow determination of the cause of Ty3 restriction in G<sub>1</sub> and might also uncover previously unknown aspects of the Ty3 life cycle. This information will be useful in understanding the relationship of retroviruslike elements to their hosts' cell cycles. Such studies may uncover general aspects of the life cycle of retroviruslike elements that are related to the state of the host cell cycle.

#### ACKNOWLEDGMENTS

We thank J. Hopper, S. Roeder, I. Herskowitz, and V. MacKay for gifts of plasmids. We thank J. Hofmann and J. Gu for work on CA and IN antibodies.

This work was supported by a Public Health Service training grant from the National Cancer Institute (T.M.M.), a postdoctoral fellowship from the American Cancer Society (T.M.M.), and American Cancer Society grant VM10 (S.B.S.).

#### REFERENCES

- Adams, B. G. 1972. Induction of galactokinase in *Saccharomyces cerevisiae*: kinetics of induction and glucose effects. *J. Bacteriol.* **111**:308-315.
- Alani, E., L. Cao, and N. Kleckner. 1987. A method for gene disruption that allows repeated use of *URA3* selection in the construction of multiply disrupted yeast strains. *Genetics* **116**:541-545.
- Ausubel, F. M., R. Brent, R. E. Kingston, D. D. Moore, J. G. Seidman, J. A. Smith, and K. Struhl (ed.). 1994. Current protocols in molecular biology. Current Protocols Inc., Brooklyn, N.Y.
- Bilanchone, V. W., J. A. Claypool, P. T. Kinsey, and S. B. Sandmeyer. 1993. Positive and negative regulatory elements control expression of the yeast retrotransposon Ty3. *Genetics* **134**:685-700.
- Boeke, J. D., F. Lacroute, and G. R. Fink. 1984. A positive selection for mutants lacking orotidine-5'-phosphate decarboxylase activity in yeast: 5-fluoro-orotic acid resistance. *Mol. Gen. Genet.* **197**:345-346.
- Boeke, J. D., and S. B. Sandmeyer. 1991. Yeast transposable elements, p. 193-261. In J. R. Broach, E. W. Jones, and J. Pringle (ed.), *The molecular biology of the yeast Saccharomyces*. Cold Spring Harbor Laboratory Press, Cold Spring Harbor, N.Y.
- Bradford, M. M. 1976. A rapid and sensitive method for the quantitation of microgram quantities of protein utilizing the principle of protein-dye binding. *Anal. Biochem.* **72**:248-254.
- Bukrinsky, M. I., S. Haggerty, M. P. Dempsey, N. Sharova, A. Adzhubel, L. Spitz, P. Lewis, D. Goldfarb, M. Emerman, and M. Stevenson. 1993. A nuclear localization signal within HIV-1 matrix protein that governs infection of non-dividing cells. *Nature (London)* **365**:666-669.
- Bukrinsky, M. I., N. Sharova, M. P. Dempsey, T. L. Stanwick, A. G. Bukrinskaya, S. Haggerty, and M. Stevenson. 1992. Active nuclear import of human immunodeficiency virus type 1 preintegration complexes. *Proc. Natl. Acad. Sci. USA* **89**:6580-6584.
- Chalker, D. L., and S. B. Sandmeyer. 1990. Transfer RNA genes are genomic targets for *de novo* transposition of the yeast retrotransposon Ty3. *Genetics* **126**:837-850.
- Chalker, D. L., and S. B. Sandmeyer. 1992. Ty3 integrates within the region of RNA polymerase III transcription initiation. *Genes Dev.* **6**:117-128.
- Chalker, D. L., and S. B. Sandmeyer. 1993. Sites of RNA polymerase III transcription initiation and Ty3 integration at the U6 gene are positioned by the TATA box. *Proc. Natl. Acad. Sci. USA* **90**:4927-4931.
- Chang, F., and I. Herskowitz. 1990. Identification of a gene necessary for cell cycle arrest by a negative growth factor of yeast: *FARI* is an inhibitor of a G1 cyclin, *CLN2*. *Cell* **63**:999-1011.
- Clark, D. J., V. W. Bilanchone, L. J. Haywood, S. L. Dildine, and S. B. Sandmeyer. 1988. A yeast sigma composite element, Ty3, has properties of a retrotransposon. *J. Biol. Chem.* **263**:1413-1423.
- Coney, L. R., and G. S. Roeder. 1988. Control of yeast gene expression by transposable elements: maximum expression requires a functional Ty activator sequence and a defective Ty promoter. *Mol. Cell. Biol.* **8**:4009-4017.
- Fritsch, E., and H. M. Temin. 1977. Inhibition of viral DNA synthesis in stationary chicken embryo fibroblasts infected with avian retroviruses. *J. Virol.* **24**:461-469.
- Fritsch, E., and H. M. Temin. 1977. Formation and structure of infectious DNA of spleen necrosis virus. *J. Virol.* **21**:119-130.
- Gartner, S., P. Markovits, D. M. Markovitz, M. H. Kaplan, R. C. Gallo, and M. Popovic. 1986. The role of mononuclear phagocytes in HTLV-III/LAV infection. *Science* **233**:215-219.
- Hansen, L. J., D. L. Chalker, K. J. Orlinsky, and S. B. Sandmeyer. 1992. Ty3 *GAG3* and *POL3* genes encode the components of intracellular particles. *J. Virol.* **66**:1414-1424.
- Hansen, L. J., D. L. Chalker, and S. B. Sandmeyer. 1988. Ty3, a yeast retrotransposon associated with tRNA genes, has homology to animal retroviruses. *Mol. Cell. Biol.* **8**:5245-5256.
- Hansen, L. J., and S. B. Sandmeyer. 1990. Characterization of a transpositionally active Ty3 element and identification of the Ty3 integrase protein. *J. Virol.* **64**:2599-2607.
- Harel, J., E. Rassart, and P. Jolicœur. 1981. Cell cycle dependence of synthesis of unintegrated viral DNA in mouse cells newly infected with murine leukemia virus. *Virology* **110**:202-207.
- Ho, D. D., T. R. Rota, and M. S. Hirsch. 1986. Infection of monocyte/macrophages by human T lymphotropic virus type III. *J. Clin. Invest.* **77**:1712-1715.
- Hofmann, J. Personal communication.
- Hsu, T. W., and J. M. Taylor. 1982. Effect of aphidicolin on avian sarcoma virus replication. *J. Virol.* **44**:493-498.
- Ihle, J. N., F. T. Kenney, and R. W. Tennant. 1974. Evidence for a stable intermediate in leukemia virus activation in AKR mouse embryo cells. *J. Virol.* **14**:451-456.

27. Johnston, M. 1987. A model fungal gene regulatory mechanism: the *GAL* genes of *Saccharomyces cerevisiae*. *Microbiol. Rev.* **51**: 458–476.
28. Johnston, M., and M. Carlson. 1992. Regulation of carbon and phosphate utilization, p. 193–281. *In* J. R. Broach, E. W. Jones, and J. Pringle (ed.), *The molecular biology of the yeast Saccharomyces*. Cold Spring Harbor Laboratory Press, Cold Spring Harbor, N.Y.
29. Johnston, M., and R. W. Davis. 1984. Sequences that regulate the divergent *GAL1-GAL10* promoter in *Saccharomyces cerevisiae*. *Mol. Cell. Biol.* **4**:1440–1448.
30. Keil, R. L., and G. S. Roeder. 1984. Cis-acting recombination-stimulating activity in a fragment of the ribosomal DNA of *S. cerevisiae*. *Cell* **39**:377–386.
31. Kinsey, P. K., and S. B. Sandmeyer. Genetics, in press.
32. Kirchner, J., and S. Sandmeyer. 1993. Proteolytic processing of Ty3 proteins is required for transposition. *J. Virol.* **67**:19–28.
33. Kirchner, J., S. B. Sandmeyer, and D. B. Forrest. 1992. Transposition of a Ty3 *GAG3-POL3* fusion mutant is limited by availability of capsid protein. *J. Virol.* **66**:6081–6092.
34. Kitagawa, T., and T. Aikawa. 1976. Enzyme coupled immunoassay of insulin using a novel coupling reagent. *J. Biochem.* **79**:233–236.
35. Lewis, P., M. Hensel, and M. Emerman. 1992. Human immunodeficiency virus infection of cells arrested in the cell cycle. *EMBO J.* **11**:3053–3058.
36. Liu, F.-T., M. Zinnecker, T. Hamaoka, and D. H. Katz. 1979. New procedures for preparation and isolation of conjugates of proteins and a synthetic copolymer of D-amino acids and immunochemical characterization of such conjugates. *Biochemistry* **18**: 690–697.
37. Luciw, P. A., and N. J. Leung. 1992. Mechanisms of retrovirus replication, p. 159–298. *In* J. A. Levy (ed.), *The retroviridae*, vol. 1. Plenum Press, New York.
38. MacKay, V. L. Personal communication.
39. MacKay, V. L., S. K. Welch, M. Y. Insley, T. R. Manney, J. Holly, G. C. Saari, and M. L. Parker. 1988. The *Saccharomyces cerevisiae* *BARI* gene encodes an exported protein with homology to pepsin. *Proc. Natl. Acad. Sci. USA* **85**:55–59.
40. McDougal, J. S., A. Mawle, S. P. Cort, J. K. A. Nicholson, G. D. Cross, J. A. Scheppler-Campbell, D. Hicks, and J. Sligh. 1985. Cellular tropism of the human retrovirus HTLV-III/LAV. I. Role of T cell activation and expression of the T4 antigen. *J. Immunol.* **135**:3151–3161.
41. Miller, J. H. 1972. *Bacterial genetics*. Cold Spring Harbor Laboratory Press, Cold Spring Harbor, N.Y.
42. Mullis, K. B., and F. A. Faloona. 1987. Specific synthesis of DNA *in vitro* via a polymerase-catalyzed chain reaction. *Methods Enzymol.* **155**:335–350.
43. Nasmyth, K. 1993. Regulating the HO endonuclease in yeast. *Curr. Opin. Genet. Dev.* **3**:286–294.
44. Orlinsky, K. J. Personal communication.
45. Orlinsky, K. J., and S. B. Sandmeyer. Unpublished data.
46. Parent, S. A., C. M. Fenimore, and K. A. Bostian. 1985. Vector systems for the expression, analysis and cloning of DNA sequences in *S. cerevisiae*. *Yeast* **1**:83–138.
47. Richter, A., H. L. Ozer, L. DesGroseillers, and P. Jolicoeur. 1984. An X-linked gene affecting mouse cell DNA synthesis also affects production of unintegrated linear and supercoiled DNA of murine leukemia virus. *Mol. Cell. Biol.* **4**:151–159.
48. Roe, T. Y., T. C. Reynolds, G. Yu, and P. O. Brown. 1993. Integration of murine leukemia virus DNA depends on mitosis. *EMBO J.* **12**:2099–2108.
49. Rubin, H., and H. M. Temin. 1959. A radiological study of cell-virus interaction in the Rous sarcoma. *Virology* **7**:75–94.
50. Sherman, F., G. R. Fink, and J. B. Hicks. 1986. *Methods in yeast genetics*. Cold Spring Harbor Laboratory Press, Cold Spring Harbor, N.Y.
51. Smith, P. K., R. I. Krohn, G. T. Hermanson, A. K. Mallia, F. H. Gartner, M. D. Provenzano, E. K. Fujimoto, N. M. Goeke, B. J. Olson, and D. C. Klenk. 1985. Measurement of protein using bicinchoninic acid. *Anal. Biochem.* **150**:76–85.
52. Sprague, G. R., and J. W. Thorner. 1992. Pheromone response and signal transduction during the mating process of *Saccharomyces cerevisiae*, p. 657–744. *In* J. R. Broach, E. W. Jones, and J. Pringle (ed.), *The molecular biology of the yeast Saccharomyces*. Cold Spring Harbor Laboratory Press, Cold Spring Harbor, N.Y.
53. St. John, T. P., and R. W. Davis. 1981. The organization and transcription of the galactose gene cluster of *Saccharomyces*. *J. Mol. Biol.* **152**:285–318.
54. Temin, H., and V. K. Kassner. 1974. Replication of reticuloendotheliosis virus in cell culture: acute infection. *J. Virol.* **13**:291–297.
55. Torchia, T. E., and J. E. Hopper. 1986. Genetic and molecular analysis of the *GAL3* gene in the expression of the galactose/melibiose regulon of *Saccharomyces cerevisiae*. *Genetics* **113**:229–246.
56. Trowbridge, R. S., J. Lehman, C. Torchio, and P. Brophy. 1980. Visna virus synthesized in absence of host-cell division and DNA synthesis. *Microbios* **29**:71–80.
57. Van Arsdell, S. W., G. L. Stetler, and J. Thorner. 1987. The yeast repeated element sigma contains a hormone-inducible promoter. *Mol. Cell. Biol.* **7**:749–759.
58. Varmus, H., and P. Brown. 1989. Retroviruses, p. 53–108. *In* D. E. Berg and M. M. Howe (ed.), *Mobile DNA*. American Society for Microbiology, Washington, D.C.
59. Varmus, H. E., T. Padgett, S. Heasley, G. Simon, and J. M. Bishop. 1977. Cellular functions are required for the synthesis and integration of avian sarcoma virus-specific DNA. *Cell* **11**:307–319.
60. Xu, H., and J. D. Boeke. 1991. Inhibition of Ty1 transposition by mating pheromones in *Saccharomyces cerevisiae*. *Mol. Cell. Biol.* **11**:2736–2743.
61. Yeh, C.-T., S. W. Wong, Y.-K. Fung, and J.-H. Ou. 1993. Cell cycle regulation of nuclear localization of hepatitis B virus core protein. *Proc. Natl. Acad. Sci. USA* **90**:6459–6463.
62. Zack, J. A., S. J. Arrigo, S. R. Weitsman, A. S. Go, A. Haislip, and I. S. Y. Chen. 1990. HIV-1 entry into quiescent primary lymphocytes: molecular analysis reveals a labile, latent viral structure. *Cell* **61**:213–222.