

Lawrence Berkeley National Laboratory

Recent Work

Title

ELECTRON DETACHMENT FROM 20-MeV D- IONS BY A MAGNETIC FIELD

Permalink

<https://escholarship.org/uc/item/0q65w8k4>

Authors

Kaplan, Selig N.
Paulikas, George A.
Pyle, Robert V.

Publication Date

1963-04-19

University of California
Ernest O. Lawrence
Radiation Laboratory

ELECTRON DETACHMENT FROM 20-MeV D^+ IONS
BY A MAGNETIC FIELD

TWO-WEEK LOAN COPY

*This is a Library Circulating Copy
which may be borrowed for two weeks.
For a personal retention copy, call
Tech. Info. Division, Ext. 5545*

Berkeley, California

DISCLAIMER

This document was prepared as an account of work sponsored by the United States Government. While this document is believed to contain correct information, neither the United States Government nor any agency thereof, nor the Regents of the University of California, nor any of their employees, makes any warranty, express or implied, or assumes any legal responsibility for the accuracy, completeness, or usefulness of any information, apparatus, product, or process disclosed, or represents that its use would not infringe privately owned rights. Reference herein to any specific commercial product, process, or service by its trade name, trademark, manufacturer, or otherwise, does not necessarily constitute or imply its endorsement, recommendation, or favoring by the United States Government or any agency thereof, or the Regents of the University of California. The views and opinions of authors expressed herein do not necessarily state or reflect those of the United States Government or any agency thereof or the Regents of the University of California.

UNIVERSITY OF CALIFORNIA
Lawrence Radiation Laboratory
Berkeley, California

Contract No. W-7405-eng-48

ELECTRON DETACHMENT FROM 20-MeV D^- IONS
BY A MAGNETIC FIELD

Selig N. Kaplan, George A. Paulikas, and Robert V. Pyle

April 19, 1963

Electron Detachment from 20-MeV D^- Ions
by a Magnetic Field

Selig N. Kaplan, George A. Paulikas, and Robert V. Pyle

Lawrence Radiation Laboratory
University of California
Berkeley, California

April 19, 1963

ABSTRACT

The probability of electron detachment from 20-MeV D^- ions by the Lorentz force of a magnetic field has been measured as a function of field strength. For a transit time through the magnetic field of $\approx 5 \times 10^{-10}$ sec, the detachment process becomes important at an equivalent electric field, $\underline{E} = \gamma(\underline{v}/c) \times \underline{B}$, of about 3.2×10^6 V/cm and is essentially complete at 4.2×10^6 V/cm. The results are in agreement with calculations by Hiskes and Khoe.

Electron Detachment from 20-MeV D^- Ions
by a Magnetic Field

Selig N. Kaplan, George A. Paulikas, and Robert V. Pyle

Lawrence Radiation Laboratory
University of California
Berkeley, California

April 19, 1963

I. INTRODUCTION

A particle traversing a magnetic field \underline{B} with a velocity \underline{v} experiences an electric field $\underline{E} = \gamma(\underline{v}/c) \times \underline{B}$, where $\gamma = (1 - v^2/c^2)^{-1/2}$. If the electric field in the rest frame is sufficiently strong, one or more electrons may be detached from an atom or ion.¹ The present paper describes a measurement of the detachment probability for negative hydrogen ions, in our case D^- .

Accelerator designers have discussed the desirability of accelerating negative hydrogen beams because of the relative ease of extraction from circular accelerators after stripping to neutral or positive ions.^{2,3,4} The loss of ions within the cyclotron or synchrotron through collisions with the background gas has also been considered^{1,4} and found to be a real but probably manageable problem. A more serious limitation to the development of high-energy negative hydrogen beams was suggested in 1956 by Khuri,¹ who showed that the $\gamma(\underline{v}/c) \times \underline{B}$ equivalent electric field of a typical circular accelerator would detach an electron from a negative hydrogen ion by the time that it reached a kinetic energy of perhaps 30 MeV.

The high-field short-lifetime experiments described here were undertaken as a check on the Khuri theory; at the same time Hiskes⁵ refined Khuri's calculations. The recent demonstration that a high-quality, if low-energy, proton beam could be extracted from an H^- cyclotron⁶ has renewed interest in the practical implications of electron detachment by the Lorentz force of a magnetic field. These implications for cyclotrons and synchrocyclotrons have been discussed by Judd.⁷

We note in passing that the detachment of electrons from negative helium ions in a static electric field has been measured by Riviere and Sweetman⁸ and the detachment of electrons from neutral hydrogen atoms by static electric or $\underline{v}/c \times \underline{B}$ fields has been calculated⁹ or measured^{10, 11, 12} by several groups.

II. THEORY

In this section we will outline Khuri's intentionally rough, one-dimensional WKB calculation to demonstrate the physical process, and present the results of Lykes' more precise calculations for comparison with the experiment.

Khuri assumed that the effective potential energy of the extra electron in the H^- ion is given by

$$V(x) = - \frac{Ze^2}{x} - e \mathcal{E} x, \quad (1)$$

where $\mathcal{E} = \gamma(\underline{v}/c) \times \underline{B}$, and x is the displacement of the electron from the center of mass. The first term is a Coulomb potential in which Z is assigned the value $Z = 0.24$ (instead of $Z = 1$) to make the binding energy of the extra electron equal to 0.76 eV. The potential energy is sketched in Fig. 1. The top curve is for the case in which there is no external field and the detachment lifetime τ is infinite. The bottom curve is for the maximum energy in the Princeton-Pennsylvania proton synchrotron (3 BeV in a 14-kG field); the second electron is not bound at all. The central curve is an example of a case in which the second electron is classically bound but can escape with a mean life τ by barrier penetration. In the absence of a good estimate of the H^- polarizability Khuri obtained a lower limit for τ from the barrier penetration probability formula

$$P = \exp \left(- \int_{x_1}^{x_2} \left\{ \frac{8m}{\hbar^2} [V(x) - E] \right\}^{1/2} dx \right)$$

and a vibration frequency for the electron of 10^{14} sec^{-1} . Thus $\tau \approx 1/(10^{14} P)$. A curve of lifetime vs electric field calculated according to the above model is labeled K in Fig. 2.¹³

Hiskes⁵ has made a three-dimensional WKB calculation using a value of $2.5 \times 10^{15} \text{ sec}^{-1}$ for the orbital frequency and correcting for the effective solid angle for barrier penetration (one-tenth of the total solid angle, for the conditions of our experiment). He obtained curve C of Fig. 1 in reference 7 and Fig. 2 in this paper by using a shielded potential,

$$V(r) = -\frac{e^2}{a_0} \left(1 + \frac{a_0}{r}\right)^{-2r/a_0} + \frac{1}{2} a_{H^-} \mathcal{E}^2 - e\mathcal{E}r \quad (2)$$

(a_0 = Bohr radius),

and recent calculations¹⁴ of the electron binding energy, 0.755 eV, and polarizability¹⁵ of the H^- ion, $a_{H^-} = 212 a_0^3$. Curves U and L represent the estimated limits of uncertainty of this calculation (a factor of three in τ). It is also possible to include a term in $V(r)$ to account for the polarization of the neutral core of the H^- ion by the second electron, $-1/2 a_H (e^2/r)^2$, where $a_H = 9/4 a_0^3$. The effect of this term would be to reduce by a small amount the electric field required for detachment in a given time.

Also shown in Fig. 2 is a recent unpublished calculation by Khoe,¹⁶ who used a square-well potential.

III. EXPERIMENTAL PROCEDURE

The experiment was performed in a pulsed magnetic field, with nuclear emulsions as particle detectors. The 20-MeV D^- beam¹⁷ of the Berkeley heavy-ion linear accelerator (Hilac) was bent through a 15-deg angle to remove the products of gas stripping in the accelerator and the beam transport system. Single beam pulses with a full width of 50 μ sec were obtained by adjusting the timing of the pulsed source and the rf excitation of the Hilac. The negative ions entered the 430- μ sec quarter-cycle-time magnetic field at its peak; the magnetic field was, therefore, constant in time to within 1% during the beam pulse.

The magnet¹⁸ is a high-field coil of Bitter design, potted in an epoxy resin so that it could be operated in a vacuum ($\approx 10^{-5}$ mm Hg), and is powered by a small capacitor bank (4000 μ F, 5000 V). The magnetic field obtainable in the original 5-cm-diam bore was sufficient to cause detachment according to the first estimates, but no breakup was observed. We therefore inserted a flux concentrator with a bore 2.5 cm in diameter into the magnet, thus raising the maximum field to 160 kG.

The beam entered the magnet perpendicular to the field through a hole 1.2-cm high and 1.9-cm wide. Data were recorded with 50- μ C-2 nuclear emulsions that followed the contour of the magnet bore (Fig. 3). A 1-mm-wide slit, parallel to the magnetic axis, collimated the beam at the beginning of the high-field region. External to the Bitter magnet was a movable set of slits that collimated the beam parallel to the magnetic field.

Before each exposure a pair of fiducial marks was put on the emulsion by pulsing the beam with zero magnetic field. A single deflected pulse was then recorded at high magnetic field, giving the appearance shown schematically in Fig. 4. The strength of the field during each pulse was monitored by integrating

the output of a single-turn loop which was solidly attached to the flux concentrator. The beam pulse (monitored by a plastic scintillator) and the magnetic field pulse were simultaneously displayed on separate sweeps of an oscilloscope.

A small calibrated search coil was used to map the magnitude and shape of the field before, during, and after the accelerator run.¹⁹ The field was flat to within 1% over a 1-cm path at the center of the magnet and dropped to 90% of the central value at a radius of 1.1 cm (Fig. 5). (From Fig. 2 we see that a 10% change in field is approximately equal to a factor of two change in the detachment lifetime.)

A semiquantitative measurement of the electron detachment as a function of magnetic field was obtained by scanning the emulsions with a low-power microscope.²⁰ In this way we estimated that clear-cut evidence of stripping was observed at 82 ± 4 kG, and that the breakup was complete at 100 ± 5 kG. We interpolated that the D^- beam would be reduced by a factor of e at a magnetic field of perhaps 94 kG, which is equivalent to an electric field of 4.2×10^6 V/cm (1 kG is equivalent to 4.44×10^4 V/cm in this experiment). This rather imprecisely determined point falls on Hiskes' curve C, Fig. 2.

The emulsions were then scanned at higher power and the tracks were individually counted. A typical profile is shown in Fig. 6. Detachment probabilities (Fig. 7) were obtained by dividing the track-density profiles into charged and neutral components. The vertical bars represent estimated limits on the uncertainty of the method of analysis; the horizontal bars give the estimated uncertainty in the absolute calibration of the magnetic field. Both kinds of errors are chiefly systematic rather than statistical.

For comparing the experimental results with theory the equivalent electric field, \mathcal{E} , in the bore was approximated by (cf. Fig. 5):

$$0 \leq r \leq \frac{R}{2}, \quad \mathcal{E} = 0.9 \mathcal{E}_0 + 0.1 \mathcal{E}_0 \sin \frac{r}{R} \pi,$$

$$\frac{R}{2} \leq r \leq \frac{3}{2} R, \quad \mathcal{E} = \mathcal{E}_0, \quad (3)$$

$$\frac{3}{2} R \leq r \leq 2 R, \quad \mathcal{E} = 0.9 \mathcal{E}_0 - 0.1 \mathcal{E}_0 \sin \frac{r}{R} \pi,$$

where R is the bore radius. The mean life, τ was approximated by an analytical form suggested by Hiskes:⁵

$$\tau = \frac{a}{\mathcal{E}^2} \exp\left(\frac{\beta}{\mathcal{E}}\right), \quad (4)$$

where a and β were obtained by a least-squares fit to points on Hiskes' lifetime curve, C in Fig. 2. The equation obtained was

$$\tau_C = \frac{1.05 \times 10^{-14}}{\mathcal{E}} \exp \frac{49.25}{\mathcal{E}} \quad (5)$$

(τ_L and τ_U are obtained from their defined relationship to τ_C , $3\tau_L = \tau_C = \tau_U/3$).

Checking of the position and shape of the observed emulsion profile (Fig. 6) required several other considerations. Due to the fringing field the beam emerged from the thin slit into the main field region (Fig. 3) with an angular displacement γ . (It should be noted that this effect prevented us from using the beam position in the emulsion to obtain an absolute value for the peak field B_0 . We instead used the independently measured field values to obtain γ .)

If we designate the ion path by l then the probability of stripping in a distance dl at l is

$$P(l) dl = \exp\left(-\int_0^l \frac{1}{\tau v} dl'\right) \frac{dl}{\tau v}.$$

We related l to the emulsion track displacement y by the small-angle approximation

$$l = 2R - (4R^2 + 4pR\gamma - 2p\gamma)^{1/2},$$

where ρ is the radius of curvature due to the average field. Taking $a = 0.30 \times 10^{-14}$ [Eqs. (4) and (5)] and integrating over the effective slit width (0.07 cm) gave the solid-line curve of Fig. 6.

The curves in Fig. 7 show the fractional detachment as would be predicted by Hiskes. As in Fig. 2, curves U and L are considered to be the limits of uncertainty in the calculation. The curves were obtained by using the relationships of Eqs. (3) and (5) to integrate numerically the expression

$$\text{Fractional detachment} = 1 - \exp \left(- \int_0^{2R} \frac{1}{\tau v} dl \right) .$$

These curves are approximately equivalent to those for fractional detachment by a uniform field in 5×10^{-10} sec.

A comparison of these curves with the measured results leads us to conclude that experiment and theory are in agreement, within the uncertainties of each, with the best agreement in the direction of Hiskes' lower estimates for the lifetimes at a given field. ²¹

ACKNOWLEDGMENTS

The authors wish to express their appreciation to Dr. Chester M. Van Atta for supporting and encouraging this research. One of us (S. N. K.) gratefully acknowledges the support of Professor Burton J. Moyer, which enabled him to participate in this work.

We also wish to thank Klaus H. Berkner, Vincent J. Honey, Henry F. Rugge, and J. Warren Stearns for much help in the preparation and execution of the experiment; and Barbara S. Levine, who provided invaluable assistance with the numerical calculations. All of the members of the Hilac staff were extremely cooperative. Very special thanks are due Dr. John R. Hiskes for allowing us to use his unpublished calculations, and for many discussions.

FOOTNOTE AND REFERENCES

1. N. N. Khuri, Palmer Physical Laboratory, Princeton University Report PPAD 124, July 1956 (unpublished).
2. J. H. Fremlin and V. M. Spiers, Proc. Phys. Soc. (London) A 68, 398 (1955).
3. G. K. O'Neill, in Proceedings of the CERN Symposium on High Energy Accelerators and Pion Physics, Geneva, 1, 64 (1956).
4. B. T. Wright, Arch. Math. Naturvid. (Oslo) 54, 8 (1957).
5. John R. Hiskes (Lawrence Radiation Laboratory, Livermore, California), private communication.
6. M. E. Rickey and W. R. Smythe, Nucl. Instr. Methods 18, 19, 66 (1962).
7. David L. Judd, Nucl. Instr. Methods 18, 19, 70 (1962).
8. A. C. Riviere and D. R. Sweetman, Phys. Rev. Letters 5, 560 (1960).
9. John R. Hiskes, Nucl. Fusion 2, 38 (1962).
10. A. C. Riviere and D. R. Sweetman, in Proceedings of the Fifth International Conference on Ionization Phenomena in Gases, Munich, 1961 (North-Holland Publishing Company, Amsterdam, 1962) Vol. II, p.1236.
11. S. N. Kaplan, G. A. Paulikas, and R. V. Pyle, Phys. Rev. Letters 9, 348 (1962).
12. A. H. Futch and C. C. Damm, Lorentz Ionization Experiment, in Controlled Thermonuclear Research Semiannual Report, July through December 1962, Lawrence Radiation Laboratory Report UCRL-10607, Jan. 16, 1963, p.30 (unpublished).
13. The curve labeled K in Fig. 1 of reference 7 is apparently based on other numbers than those that were used by Khuri.¹
14. C. L. Pekeris, Phys. Rev. 112, 1649 (1958).

15. C. L. Schwartz, unpublished, quoted in reference 7.
16. T. K. Khoe, Argonne National Laboratory Report ANLAD-72, September 1962 (unpublished).
17. The experiment was carried out with D^- rather than with H^- ions because the Hilac rf stability is poor at low gradients.
18. We are very grateful to Harold P. Furth for lending us the basic magnet structure.
19. We wish to thank Mr. Joseph H. Dorst and members of his magnet testing group for the calibration of our search coil.
20. R. V. Pyle, S. N. Kaplan, and G. A. Paulikas, Bull. Am. Phys. Soc. Ser. II, 7, 487 (1962).
21. Preliminary results of an internal-beam cyclotron experiment at UCLA indicate breakup at equivalent electric fields smaller than Hiskes' curve L; Byron T. Wright (University of California, Los Angeles), private communication.

FIGURE CAPTIONS

- Fig. 1. The potential energy of the second electron vs its displacement from the center of the H^- ion, according to Khuri's model,¹ for equivalent electric field values of 0, 3×10^6 , and 1.7×10^9 V/cm.
- Fig. 2. The mean life for detachment vs electric field. Curve K is based on Khuri's original estimate;¹ K' is a calculation by Khoe¹⁶ (see text). Curve C is Hiskes' shielded potential calculation,⁵ using Eq. (2). Curves U and L are upper and lower limits on curve C.
- Fig. 3. The experimental arrangement.
- Fig. 4. Appearance of the data on an emulsion. The shaded regions have higher densities and are primarily D^- ions.
- Fig. 5. The shape of the magnetic field in the bore of the magnet and in the hole through the flux concentrator.
- Fig. 6. Typical determination of track density vs displacement on the emulsion. The method of calculation of the solid curve is described in the text. The rectangle enclosed by dotted lines represents D^- ions; the two approximately triangular sections D^0 atoms. The experimental points represent a total of 3990 tracks.
- Fig. 7. The solid lines give the fractional detachment vs equivalent electric field calculated as described in the text. The abscissa represents the equivalent electric field at the center of the magnet.

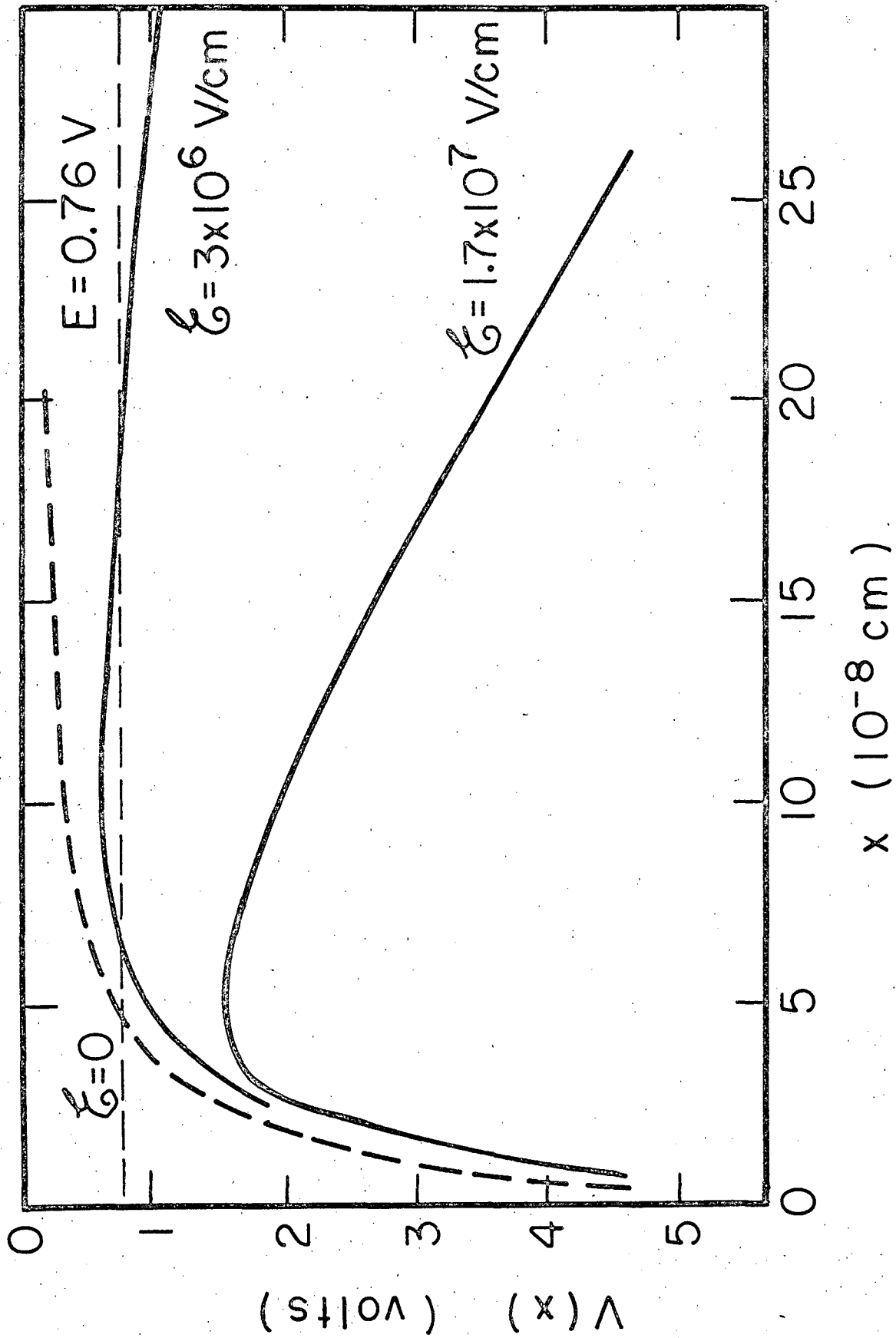

Fig. 1.

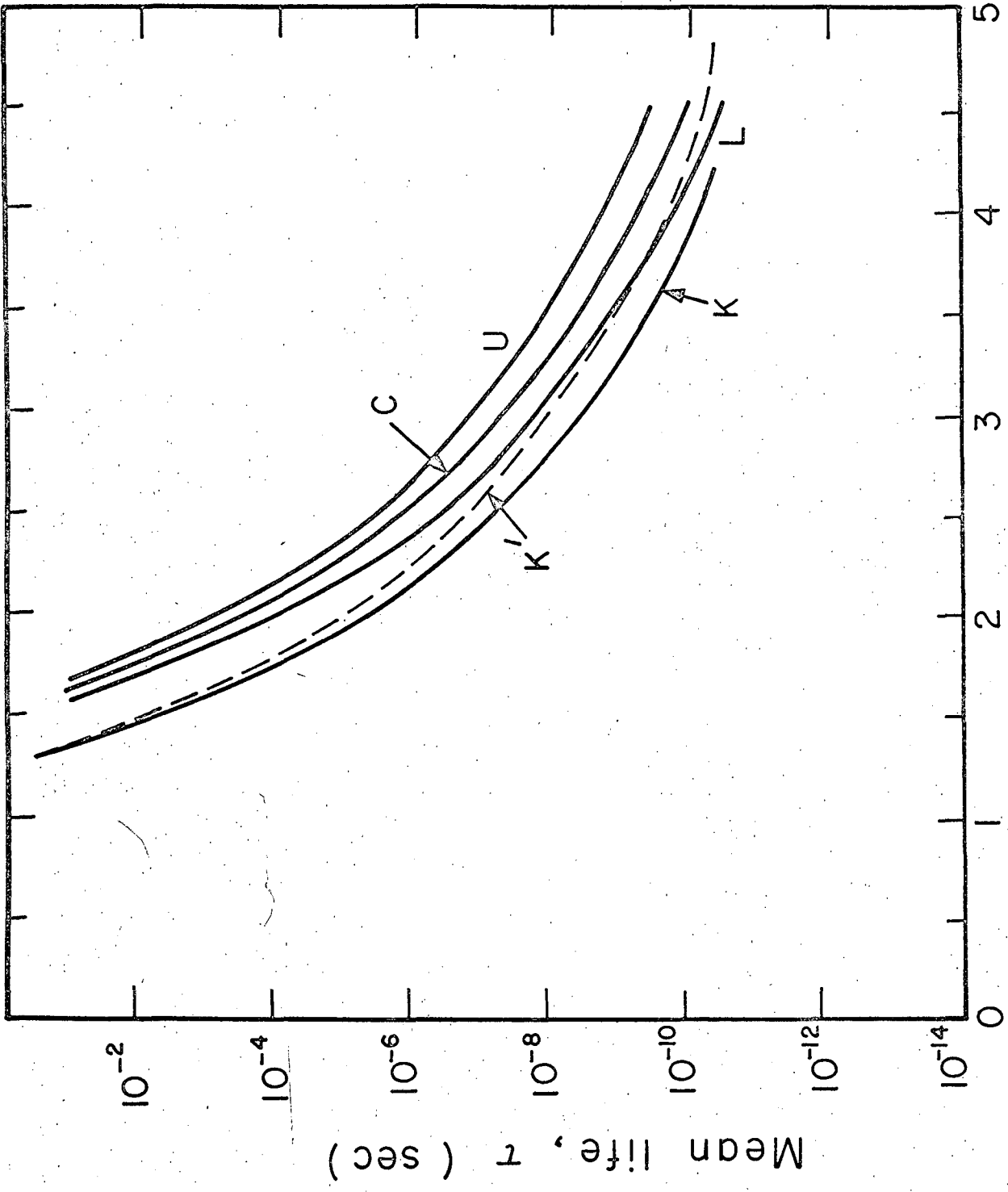

Fig. 2.

MU-27730

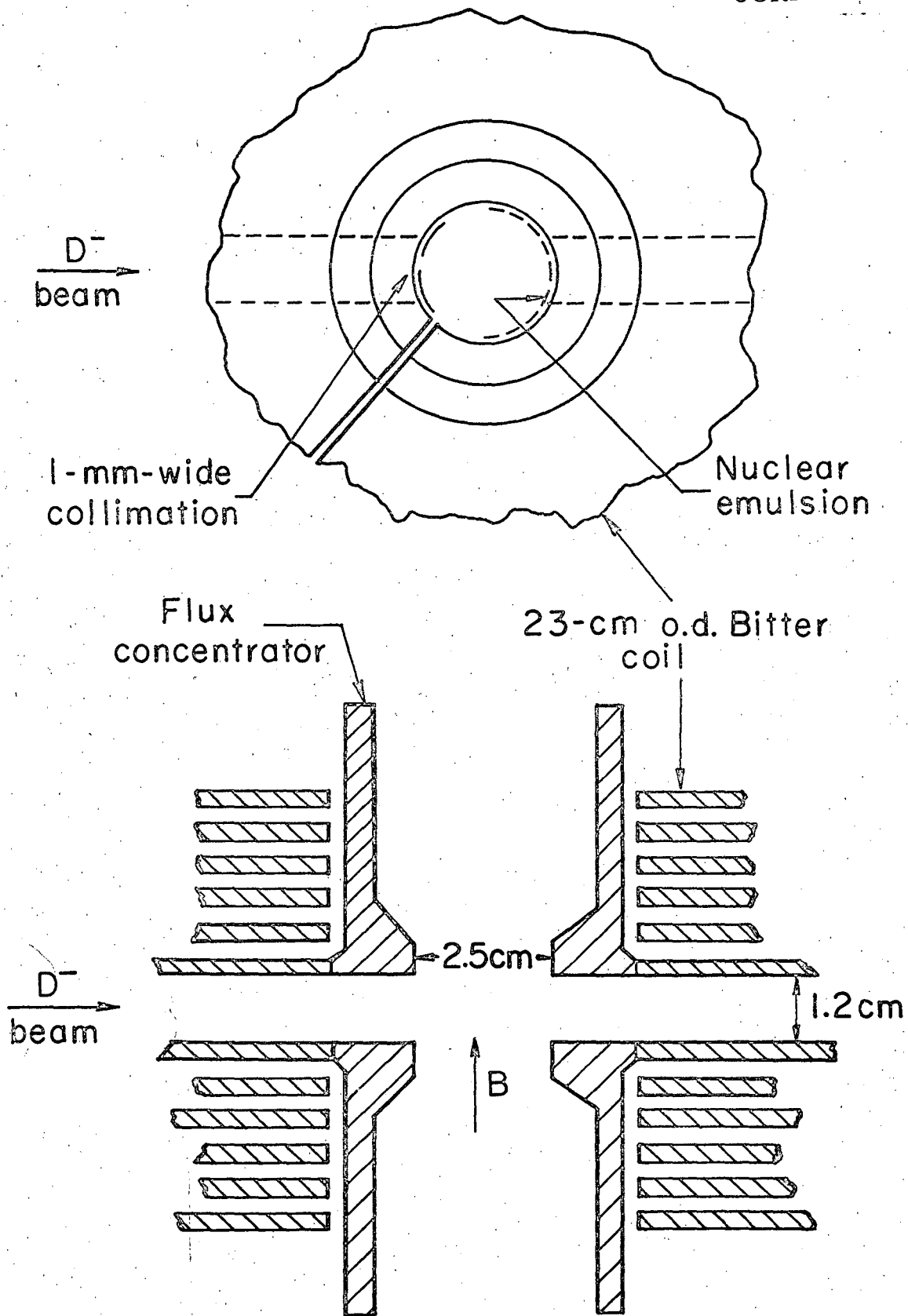

Fig. 3.

MU-27731

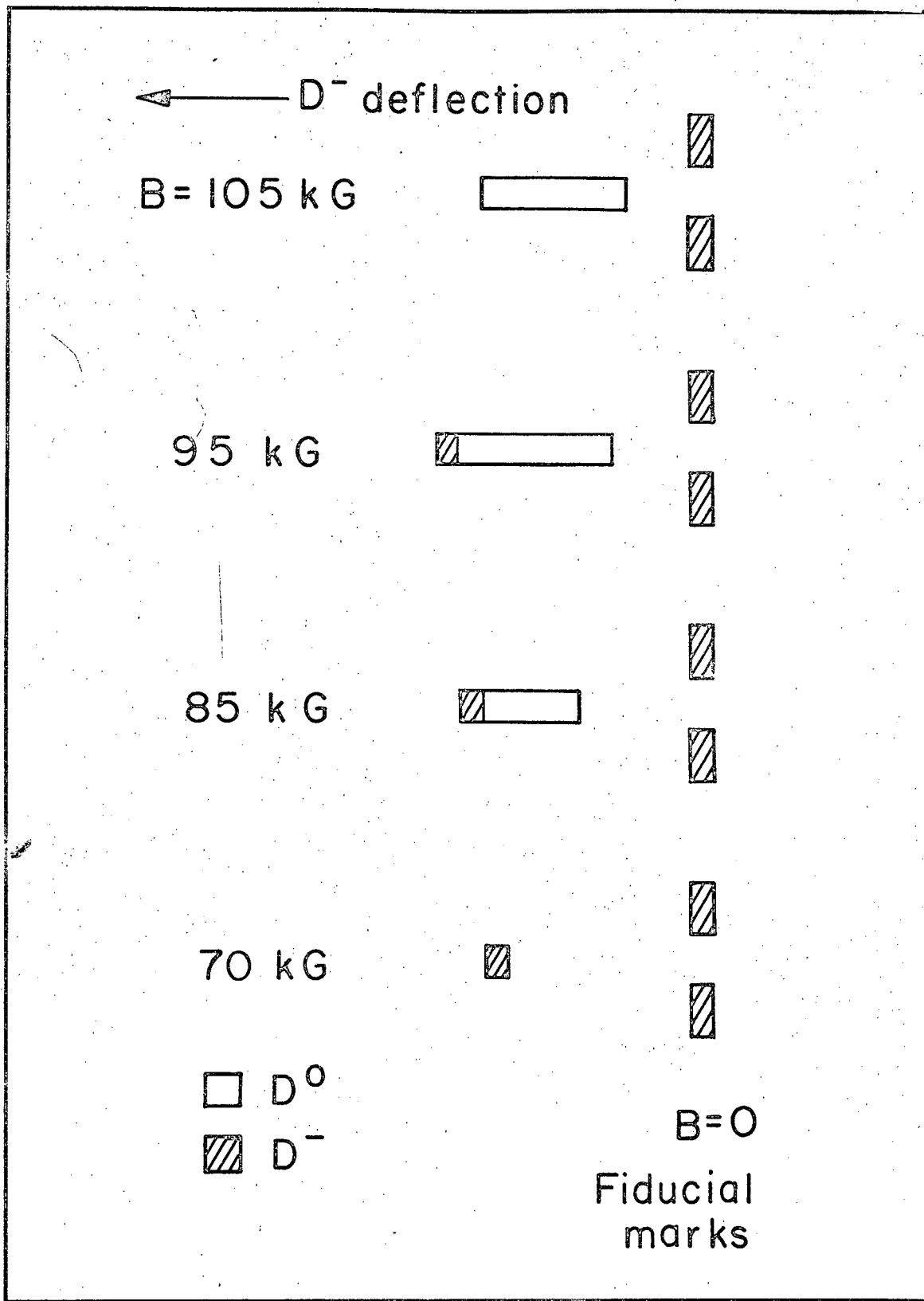

Fig. 4.

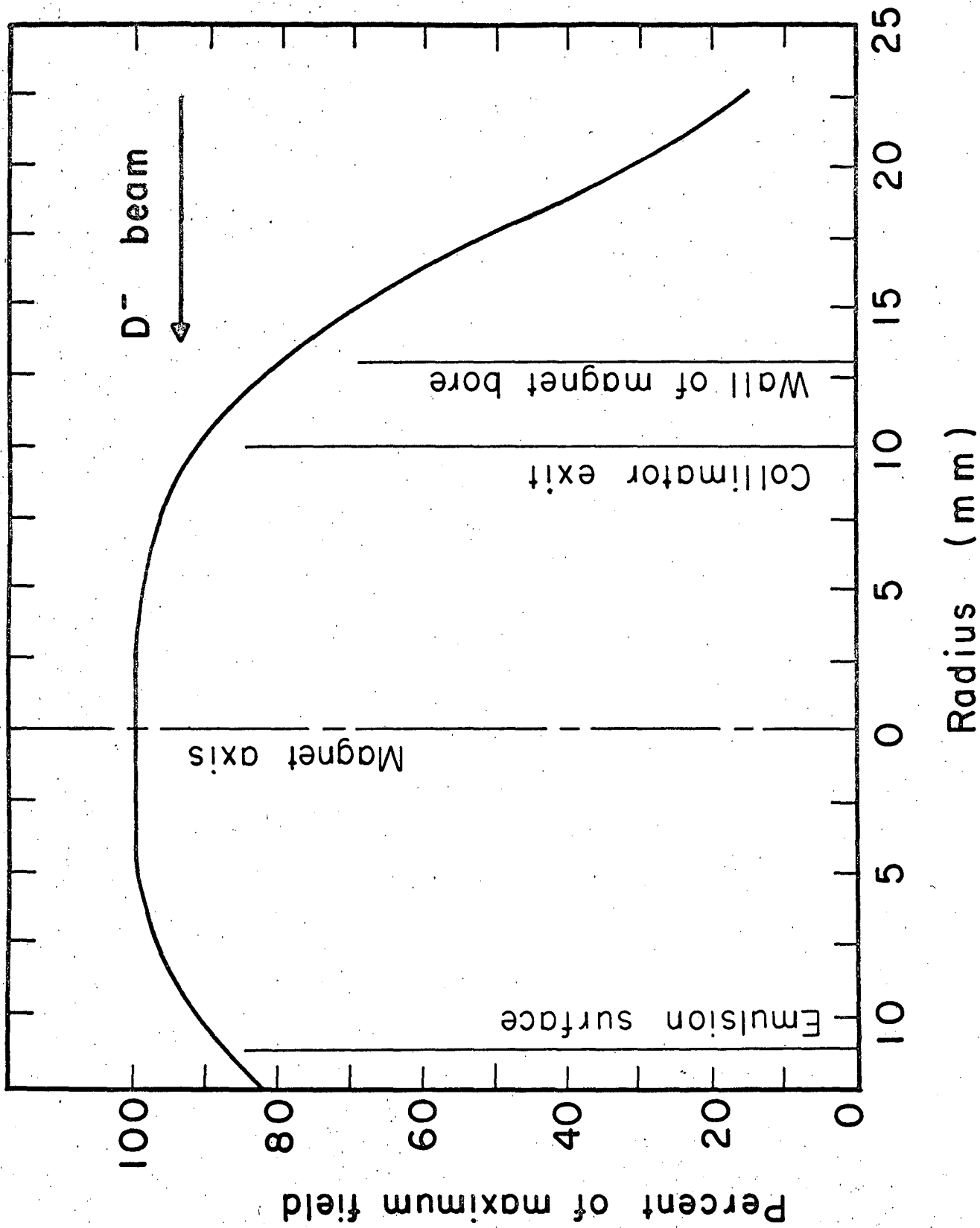

Fig. 5.

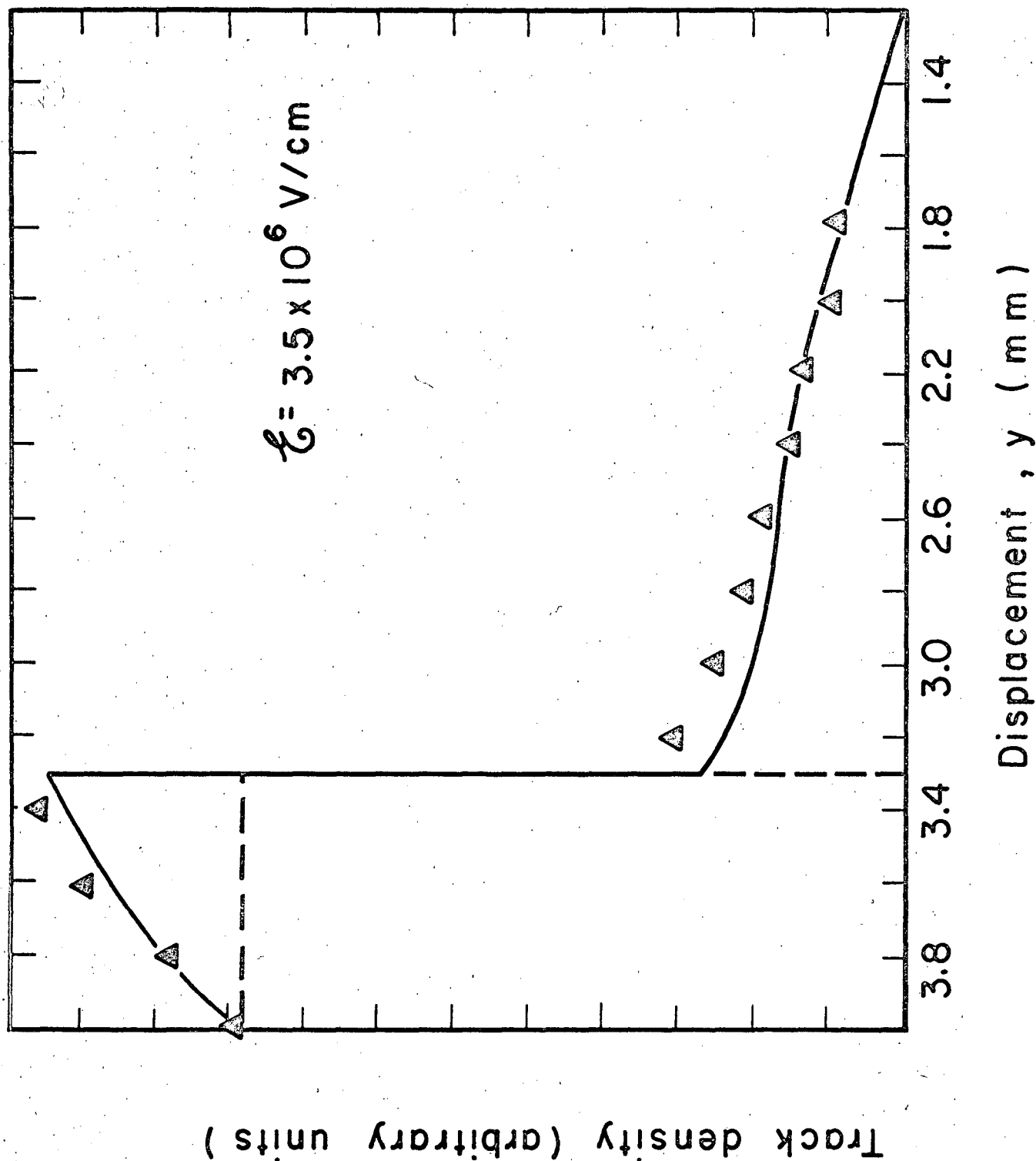

Fig. 6.

