

Lawrence Berkeley National Laboratory

LBL Publications

Title

Short Sample Testing Facility for the Superconducting Super Collider: Requirements and Development Status

Permalink

<https://escholarship.org/uc/item/0j83r7wk>

Authors

Zbasnik, J

Scanlan, R

Taylor, C

et al.

Publication Date

1989-06-01

Copyright Information

This work is made available under the terms of a Creative Commons Attribution License, available at <https://creativecommons.org/licenses/by/4.0/>



Lawrence Berkeley Laboratory

UNIVERSITY OF CALIFORNIA

Accelerator & Fusion Research Division

Presented at the 1989 Cryogenic Engineering Conference/
International Cryogenic Materials Conference (CEC/ICMC)
Los Angeles, CA, July 24-28, 1989

Short Sample Testing Facility for the Superconducting Super Collider: Requirements and Development Status

J. Zbasnik, R. Scanlan, C. Taylor, C. Peters, W. Pope,
and J. Royet

June 1989

For Reference

Not to be taken from this room

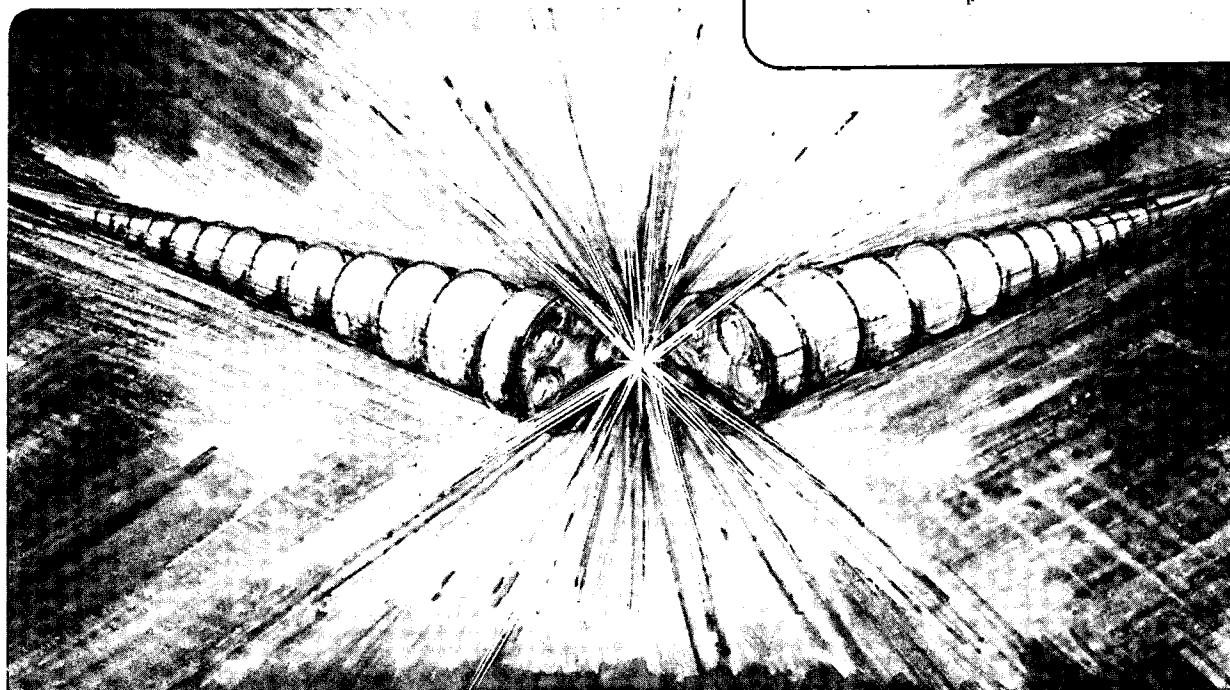

DISCLAIMER

This document was prepared as an account of work sponsored by the United States Government. While this document is believed to contain correct information, neither the United States Government nor any agency thereof, nor the Regents of the University of California, nor any of their employees, makes any warranty, express or implied, or assumes any legal responsibility for the accuracy, completeness, or usefulness of any information, apparatus, product, or process disclosed, or represents that its use would not infringe privately owned rights. Reference herein to any specific commercial product, process, or service by its trade name, trademark, manufacturer, or otherwise, does not necessarily constitute or imply its endorsement, recommendation, or favoring by the United States Government or any agency thereof, or the Regents of the University of California. The views and opinions of authors expressed herein do not necessarily state or reflect those of the United States Government or any agency thereof or the Regents of the University of California.

SSC-MAG-245
LBL-26619

**SHORT SAMPLE TESTING FACILITY FOR THE SUPERCONDUCTING
SUPER COLLIDER: REQUIREMENTS AND DEVELOPMENT STATUS***

J. Zbasnik, R. Scanlan, C. Taylor, C. Peters, W. Pope, and J. Royet

Accelerator & Fusion Research Division
Lawrence Berkeley Laboratory
1 Cyclotron Road
Berkeley, CA 94720

June 1989

*This work is supported by the Office of Energy Research, Office of High Energy and Nuclear Physics, High Energy Physics Division, Dept. of Energy under Contract No. DE-AC03-76SF00098.

SHORT SAMPLE TESTING FACILITY FOR THE SUPERCONDUCTING SUPER COLLIDER: REQUIREMENTS AND DEVELOPMENT STATUS*

J. Zbasnik, R. Scanlan, C. Taylor, C. Peters, W. Pope, and J. Royet

Lawrence Berkeley Laboratory
1 Cyclotron Road
Berkeley, CA 94720

INTRODUCTION

In this paper we present the system requirements of the apparatus for measuring the short sample critical current of the cable for the Superconducting Super Collider (SSC), and the current status of our development work. Key features of the system presented here are: (1) a sample holder which clamps the samples sufficiently well such that no training quenches are required to perform critical current measurements and another which may allow for faster sample mounting; (2) voltage tap boards using a printed-circuit technique which eliminates the necessity of soldering wires for the voltage measurements; (3) a 1-m long, 5-cm-bore dipole magnet with close-in iron designed to produce 7.5 T with a 6000 A excitation current; and (4) an air-lock system that allows repeated sample changes without the magnet chamber being contaminated with air and other impurities.

REQUIREMENTS

A central testing facility for measuring the short sample critical current of production cable for the SSC (1) must keep pace with the peak anticipated magnet production schedule of 2800 magnets/year. The sampling frequency presently under consideration requires a measurement of the critical current at the start and finish of each cable run. Assuming no breakage, each cable run will furnish conductor for 6 coils, or 1.5 dipole magnets, so we would have to measure 3750 samples/year, or about 15 samples/day for a 255-day-year. Cable breakage during manufacturing will require additional testing, since short sample measurements will have to be made on each end of the resulting segments. If we assume that 20 % of the time there will be one break in the 6 coil length and 10 % of the lengths will have 2 breaks, the peak testing rate will be 5320 samples/year or about 20 samples/day for the 255-day-year.

We intend to base our system on the Brookhaven National Laboratory (BNL)-type system, in which 1-m-long straight samples are inserted in the bore of a superconducting dipole which provides a transverse ambient magnetic field. The 1m length is a minimum in order to have a signal level of a few μV at a resistivity of $5 \times 10^{-15} \Omega\text{-m}$.

*This work is supported by the Office of Energy Research, Office of High Energy and Nuclear Physics, High Energy Physics Division, Dept. of Energy under Contract No. DE-AC03-76SF00098.

In these tests, the inner layer conductor is to be subjected to an ambient magnetic field of approximately 7 T and a temperature of 4.35 K and the current through the sample ramped until an effective resistivity of about $1 \times 10^{-13} \Omega\cdot\text{m}$ is reached. The critical current density J_C is determined at a value of $10^{-14} \Omega\cdot\text{m}$. For the outer layer cable, a field of 5.6 T will be required. The specification value of the critical current values for these conductors is 7860A, so we make provision for a 10 kA capability to allow testing at reduced field values. Based on testing done at BNL, the SSC cable specification⁽²⁾ requires that ambient magnetic field be perpendicular to the wide face of the conductor, with the sample current polarity chosen such that the peak field, considering self field, is at the narrow edge of the keystoneed cable. This ensures that any degradation due to compaction of the thin-edge will be detected.

As a check on the absolute accuracy of the system, the measured critical currents of this facility must agree with those measured in the BNL test system to within $\pm 5\%$. Repeat tests on "standard cable samples" in the SSC facility will periodically performed to ensure a systematic agreement of $\pm 2.5\%$.

SAMPLE HOLDER

Based on a study of the steps involved in preparing and testing samples, we conclude that in order to test 20 samples/day we must use a sample holder that will allow us to test at least 4 samples per entry into the cryogenic environment. In this study, the time allotted to mount the samples in the holder was 50 minutes.⁽³⁾

A further necessity in achieving the desired testing rate is that the samples be clamped securely enough such that premature quenches, or training are eliminated. According to BNL tests on the effect of clamping pressure on training⁽⁴⁾, the transverse clamping pressure should be on the order of 70 MPa (10 ksi) to minimize training.

There should be sufficient cooling to allow stable voltage measurements at an effective resistivity of $1 \times 10^{-13} \Omega\cdot\text{m}$, wherein approximately 0.5 W are generated in the 1-m-long sample.

A cross sectional view of our first sample holder is illustrated in Figure 1. The stack of 4 cables to be tested are inserted in the brass channel, separated by insulators or voltage tap boards as required and insulated with a spiral wrap of .25 mm thick Kevlar braid. The axial and transverse cooling passages in the metallic parts connect with the spiral passage formed by the Kevlar wrap. Clamping pressure is provided by a system of Type 7075 aluminum rings with a tapered surface and Type 304 stainless steel wedges which are installed with a hydraulic press. The rings are 25.4 mm long, so the entire assembly requires that 48 rings be installed.

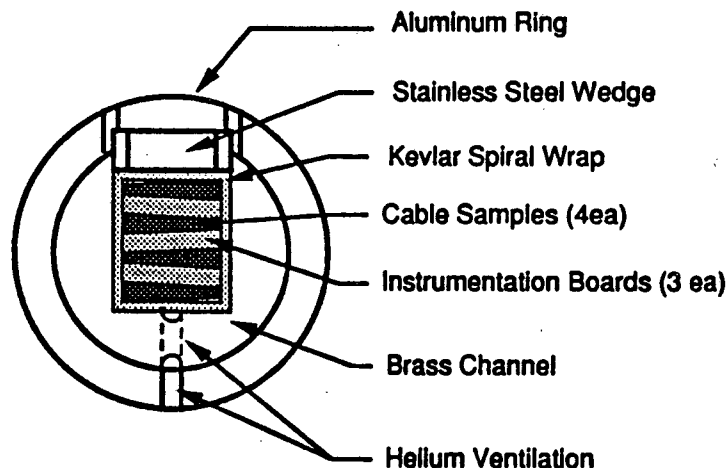

Fig. 1 Cross Sectional View of the Ring and Wedge Sample Holder.

In order to provide sufficient torsional rigidity to resist the 135 N·m (100 lb-ft) torque generated by the interaction of the sample in the magnetic field, we inserted the ring and channel assembly into a 44.5 mm outer diameter x 4.75mm thick stainless steel tube and used conical point set screws which engaged the aluminum rings to transfer the torque.

This holder was used to remeasure some difficult-to-train cables at BNL, with the result that critical current measurements were made with no training quenches. The critical currents agreed with the previous measurements to better than 1%.

Although the "ring and wedge" holder yielded satisfactory critical current results, we have started work on a second type of sample holder since we feared that the process of installing the series of rings and the necessity of removing them would be a time-consuming and tedious chore for full-speed production testing.

In this new version, the stack of samples and the requisite insulation strips and voltage taps are inserted into an aluminum tube with a square cavity. The assembly is then pulled through a die which sinks the aluminum tube around the samples. Since the pack of conductors and their insulators have a lower modulus of elasticity than the tube, the samples emerge from the die under compression. The resulting package can have sufficient torsional rigidity since it is a continuous tube. The materials are inexpensive compared to the labor saved, and the samples can be easily archived in this protective jacket.

Initial tests have been performed in which a load cell having a stiffness comparable to a stack of 4 cables was compressed in an aluminum tube 19 mm square with a 3.2 mm-thick wall, which for this purpose is relatively thin. Nonetheless, by varying the interference between the load cell and the tube we were able to apply a rather considerable load: for a 6063 Al tube in the T52 condition the maximum load was equivalent to a sample pressure of 42 Mpa (6000 psi). We repeated the test using a tube heat treated to the T6 condition and obtained a 30 % increase in residual compressive load.

Although the results were encouraging, such a thin-wall tube is not acceptable as a sample holder because there is considerable overpressure in the drawing operation (approximately double) and no possibility of reasonable helium ventilation. We have designed a more robust tube shown in Figure 2 with an octagonal outer shape and thick walls. The cross section also incorporates helium cooling channels and spaces for eventual placement of additional superconductor cross section which allows us to shunt each cable to ensure that cables with degraded critical current will not jeopardize the testing of the other samples in the assembly⁽⁵⁾. We are in the process of fabricating prototype tubes of extruded Al alloy. We will first study the ability of the tube to load the samples in compression, and then mount a set of cables with the proper insulation pieces for testing at BNL.

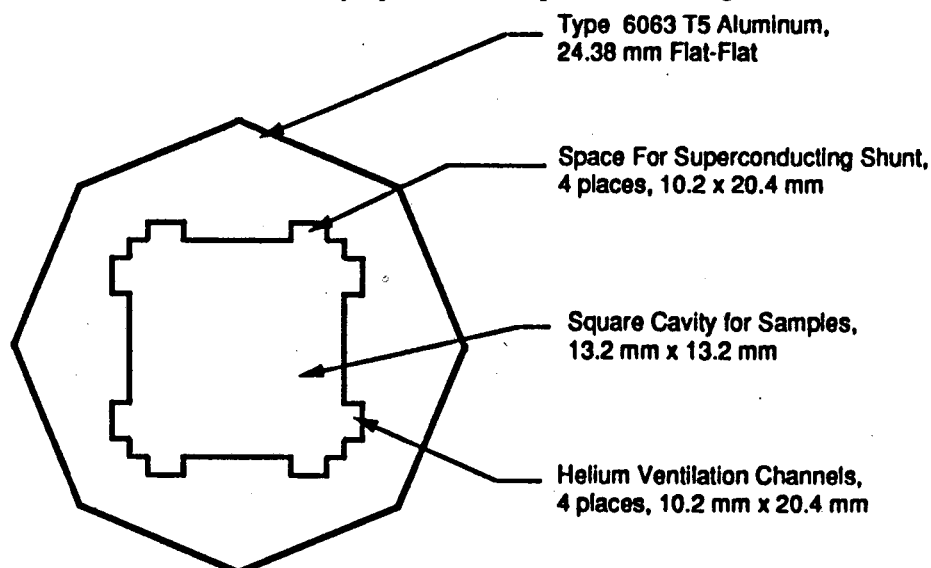

Fig. 2 Cross Sectional View of the Extruded Octagonal tube Sample Holder.

VOLTAGE TAPS

The concept of a drawn-tube sample holder requires an easily installed, inexpensive, disposable voltage tap. We have produced a voltage tap using conventional printed circuit processing, depicted in Figure 3 below. The starting material was NEMA G-10 fiberglass-reinforced epoxy laminate, coated on both sides with a .025 mm thick layer of copper, with the voltage tap pattern etched on each side. The faces are insulated with .090 mm thick Kapton tape, except for cut-outs around the voltage tap areas. The voltage tap areas are tinned with Pb-Sn solder such that the solder surface protrudes .13 mm above the Kapton surface. Since we use a double-sided board, only one board is needed for each pair of cables to be tested. The compression imparted to the stack of samples to prevent training causes the solder to flow into the interstices of the cable and make a good electrical contact. Test pieces were loaded to 70 MPa (10 ksi) with no problems.

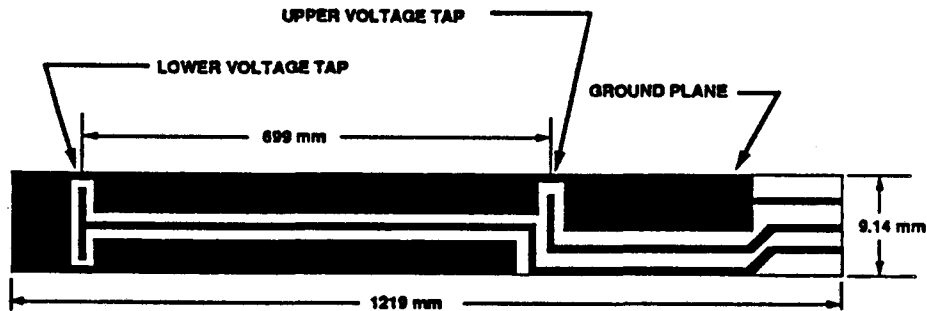

Fig. 3 Circuit Board Trace Used as a Voltage Tap.

We conducted a test, in which we loaded a stack of four 1.2-m-long cables, voltage tap boards and insulators in the 19 mm square tube described above which supplied a compression load of about 39 MPa (5500 psi). This assembly was inserted into a 1-m long SSC development dipole and cooled to 4.3 K. The voltage taps survived the loading and the cooldown. In this test, no current was passed through the cable samples, but the voltage induced in the voltage taps due to a changing magnetic field was measured. The magnet current was modulated at about 6.7 Hz with a peak-peak amplitude of 70 A, and the induced voltage recorded as a function of the angle between the field and normal to the wide face of the conductor. Figure 4 presents the results for the case in which the field is normal to the wide face. From these series of measurements we conclude that the effective flux-linking area normal to the wide face is $2.4 \times 10^{-4} \text{ m}^2$ and $4.6 \times 10^{-4} \text{ m}^2$ parallel to the wide face.

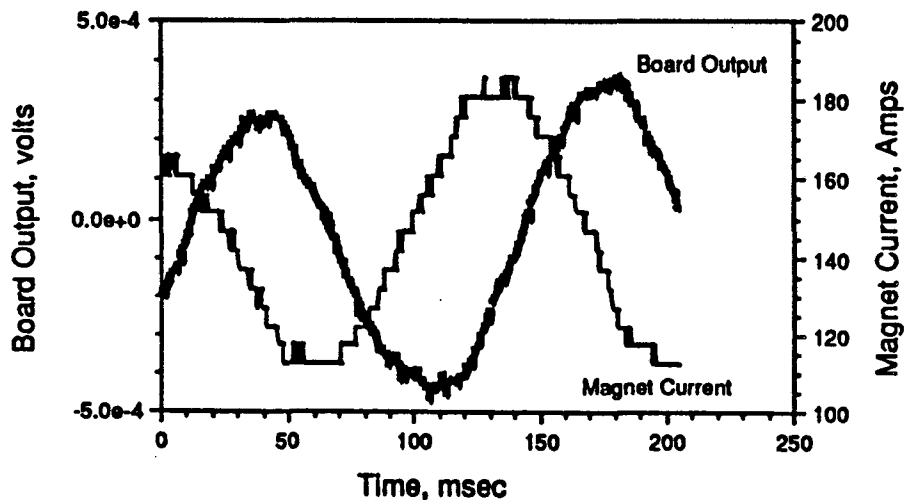

Fig. 4 Voltage Induced in the Circuit Board by a Changing Magnet Current.

MAGNET

Figure 5 shows a cross-sectional view of the magnet presently under construction for the facility which we designate as D16. The bore is 50 mm in diameter, which is large enough to accommodate the sample holder with the external torque tube and a 1.5 mm thick insulated tube. The insulated tube protects the magnet bore from mechanical scuffing as the holder is retracted and inserted and also serves to thermally isolate the magnet from the sample holder, such that sample quenches will not cause the magnet to quench.

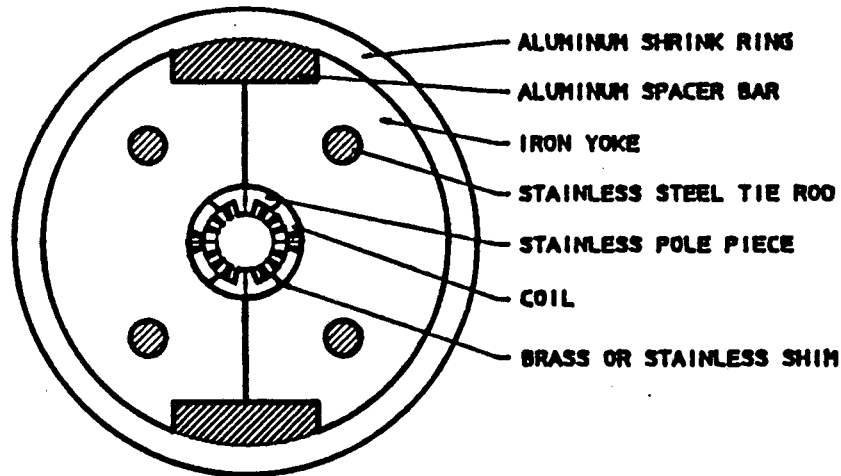

Fig. 5 Cross Sectional View of the Cable Test Facility Magnet.

This magnet features several unique aspects which will be mentioned here and discussed in a later report in detail. The inner cable is made up of 28 strands of the inner layer SSC material, and the outer cable is 36 strands of outer layer SSC material.

These cables have lower keystone angles than their SSC counterparts, since the edge thicknesses are the same as the SSC case but the widths are increased in proportion to the number of strands. The inner layer cable is 11.33 mm wide and the outer has a width of 11.68 mm.

Secondly, in order to attain the highest field possible, the iron yoke is placed in close proximity to the coils. The design field of the magnet is 7.5 T at a current of 6470 A. The short-sample limit at 4.35 K is calculated to be 7.68 T at 6625 A. Therefore, a generous margin of safety is obtained for the normal operating point of 7 T (6000 A). The coils can be replaced at a later date with a lower current winding with more turns (~2500A). Preliminary calculations⁽⁶⁾ indicate that the sextupole field component is on the order of 0.12 % of the central dipole field, which is quite adequate for this purpose.

The mechanical features of this magnet use some ideas from an earlier conceptual design of a high-field magnet⁽⁷⁾. The iron has a vertical split and the coils are prestressed by the aluminum shrink ring surrounding the iron. The ring is installed by preheating it to 180C. The size of the aluminum spacer bars, along with a gap in the iron at room temperature determines the room temperature prestress. On cooldown, the aluminum spacer bars match the coil contraction so the coil prestress is approximately maintained and the iron gap closes and is loaded by the contraction of the aluminum ring. The loading on the gap results in a structure that resists the Lorentz forces when the magnet is energized.

The aluminum spacer bars extend the full length of the magnet so they also act as locating keys for the iron yoke and aluminum ring segments which are 5.08 mm thick. The stainless steel rods are used to preload the magnet ends.

CRYOSTAT

Figure 6 is a sketch of the Cable Test Facility. The magnet is suspended vertically in the dewar, which is located in a pit for convenience. The gate valve on top of the dewar allows the sample holder to be evacuated and backfilled with boiloff helium gas in the purge lock prior to insertion to ensure that contamination of the magnet chamber is minimized.

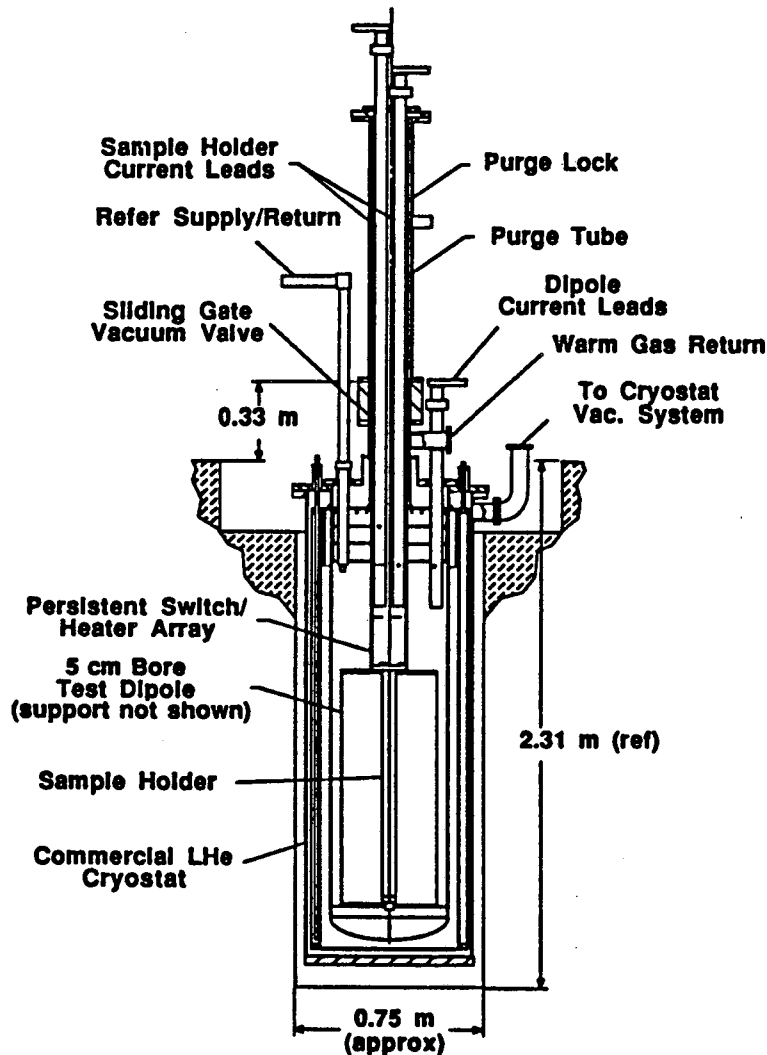

Fig. 6 Conceptual View of the Cable Test Facility Cryostat.

This arrangement requires a pair of 2-m long 10 kA current leads to power the cable samples for testing. Our leads have a design IL/A of 210 kA/cm and are based on a series of stacked flat ETP copper strips with parallel plate gas passages between them.

The estimated heat leak for the case of full power in both magnet and sample circuits is 35 W. If both the sample and magnet circuits are unpowered (standby), the heat input is about 25 W. With the sample holder removed, the heat input is on the order of 12 W.

REFERENCES

1. R.M. Scanlan, Development of Superconducting Strand and Cable with Improved Properties for use in SSC Magnets, to be published in Proc. of First International Industrial Symposium on the Super Collider, New Orleans, Feb. 1989.
2. R.M.Scanlan, NbTi Superconductor Cable for SSC Dipole Magnets, SSC-MAG-M-4142, SSC Laboratory Report, 1989.
3. C. Taylor, SSC Cable Test Facility Proposal, SSC-MAG-234, Lawrence Berkeley Laboratory Report, March 1989.
4. A.K.Ghosh, M. Garber, K.E. Robbins, and W.B. Sampson, Training in Test Samples of Superconducting Cables for Accelerator Magnets, IEEE Trans. Mag. 25:1831 (1989).
5. P. Fabbriatore, R. Parodi, and R. Vaccarone, Self Field Effects in the Critical Current Measurements of HERA Cables, private communication.
6. S. Caspi, High Field Dipole for a Short Sample Test Facility - Magnet D16A1, SSC-MAG-240, Lawrence Berkeley Laboratory Report, June 1989.
7. C.E. Taylor and S. Caspi, Design of a 9T 5 cm Bore Dipole, LBL-26005, Lawrence Berkeley Laboratory Report, July 1988.

LAWRENCE BERKELEY LABORATORY
TECHNICAL INFORMATION DEPARTMENT
1 CYCLOTRON ROAD
BERKELEY, CALIFORNIA 94720