

Lawrence Berkeley National Laboratory

Recent Work

Title

TRANSFER AND BREAKUP REACTIONS AT INTERMEDIATE ENERGIES

Permalink

<https://escholarship.org/uc/item/0h35x181>

Author

Stokstad, R.G.

Publication Date

1986-04-01

ca



Lawrence Berkeley Laboratory

UNIVERSITY OF CALIFORNIA

RECEIVED
LAWRENCE
BERKELEY LABORATORY

JUL 2 1986

LIBRARY AND
DOCUMENTS SECTION

Presented at the International Symposium on
Nuclear Fission and Heavy-Ion Induced Reactions,
Rochester, NY, April 20-22, 1986

TRANSFER AND BREAKUP REACTIONS
AT INTERMEDIATE ENERGIES

R.G. Stokstad

April 1986

TWO-WEEK LOAN COPY

*This is a Library Circulating Copy
-which may be borrowed for two weeks*

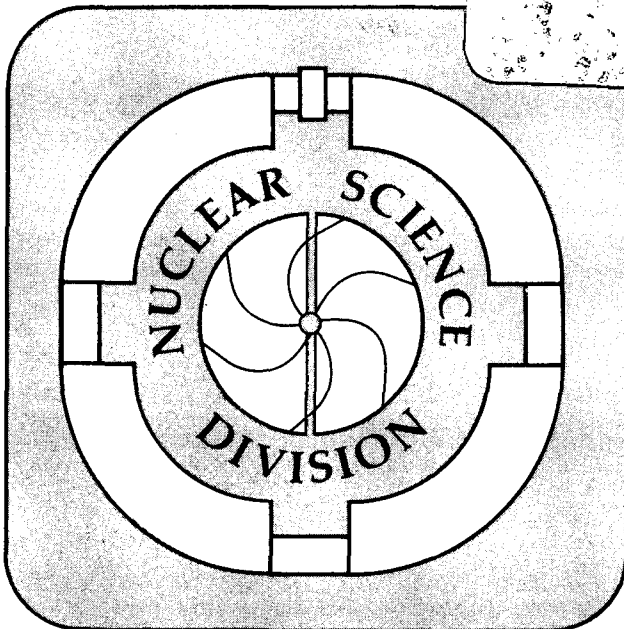

LBL-21580
ca

DISCLAIMER

This document was prepared as an account of work sponsored by the United States Government. While this document is believed to contain correct information, neither the United States Government nor any agency thereof, nor the Regents of the University of California, nor any of their employees, makes any warranty, express or implied, or assumes any legal responsibility for the accuracy, completeness, or usefulness of any information, apparatus, product, or process disclosed, or represents that its use would not infringe privately owned rights. Reference herein to any specific commercial product, process, or service by its trade name, trademark, manufacturer, or otherwise, does not necessarily constitute or imply its endorsement, recommendation, or favoring by the United States Government or any agency thereof, or the Regents of the University of California. The views and opinions of authors expressed herein do not necessarily state or reflect those of the United States Government or any agency thereof or the Regents of the University of California.

TRANSFER AND BREAKUP REACTIONS AT INTERMEDIATE ENERGIES*

ROBERT G. STOKSTAD

Nuclear Science Division
Lawrence Berkeley Laboratory
University of California
Berkeley, California 94720

April 1986

*This work was supported by the Director, Office of Energy Research, Division of Nuclear Physics of the Office of High Energy and Nuclear Physics of the U.S. Department of Energy under Contract DE-AC03-76SF00098.

TRANSFER AND BREAKUP REACTIONS AT INTERMEDIATE ENERGIES

ROBERT G. STOKSTAD
Lawrence Berkeley Laboratory, Berkeley, CA 94720

Abstract The origin of the quasi-elastic peak in peripheral heavy-ion reactions is discussed in terms of inelastic scattering and transfer reactions to unbound states of the primary projectile-like fragment. The situation is analogous to the use of reverse kinematics in fusion reactions, a technique in which the object of study is moving with nearly the beam velocity. It appears that several important features of the quasi-elastic peak may be explained by this approach. Projectile-breakup reactions have attractive features for the study of nuclear structure. They may also be used to determine the partition of excitation energy in peripheral reactions. At intermediate energies, neutron-pickup reactions leading to four-body final states become important. Examples of experiments are presented that illustrate these points.

I. INTRODUCTION AND PERSPECTIVE

Peripheral heavy-ion reactions are characterized by fragments emitted in the forward direction (or along a grazing trajectory) having velocities close to that of the projectile. The mechanisms producing the quasi-elastic peak in an inclusive energy spectrum of these fragments have been actively investigated for many years. A brief review of this subject, with particular reference to the momentum width of the projectile

R. G. STOKSTAD

fragments, is given in Ref. 1. Today, I would like to introduce the subject in a different manner, one which I hope will put the experiments in a perspective that makes many of the results seem quite natural and, indeed, predictable.

Let us begin with inelastic scattering, a peripheral process that is reasonably well understood and is well known from light ion induced reactions. A representative example is given in Fig. 1b, which shows an inclusive energy spectrum of alpha particles scattered by an ^{16}O target.²⁾ The bombarding energy is about 40 MeV per nucleon, a respectable

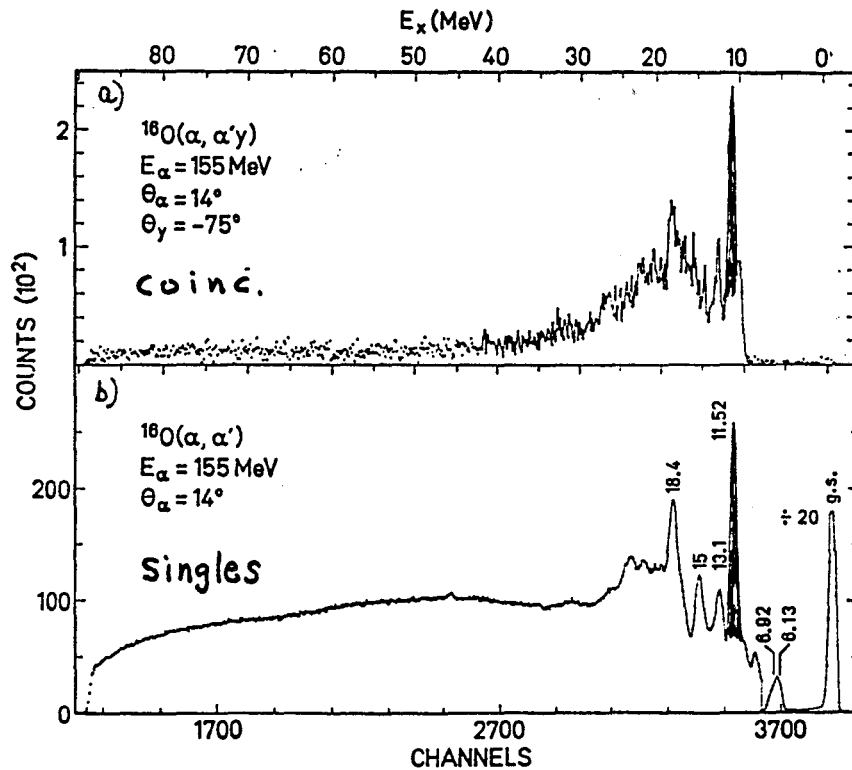

FIGURE 1. Experimental results for inelastic scattering of α particles by ^{16}O , in normal kinematics (Ref. 2) at 39 MeV/A.

R. G. STOKSTAD

"intermediate" energy, and the energy levels of ^{16}O are prominent features. In order to further study the structure of the levels in ^{16}O (or in whichever target nucleus is being bombarded), one may also wish to detect a decay product of the excited target nucleus. The coincidence spectrum resulting when charged particles are detected at 75° is shown in Fig. 1a. Of course, the particle-bound levels of ^{16}O and any other levels that decay exclusively by neutron or gamma emission are absent. Most of the structure in the region of 9-20 MeV excitation seen in the singles spectrum remains, however. Figure 2 is a schematic illustration of the

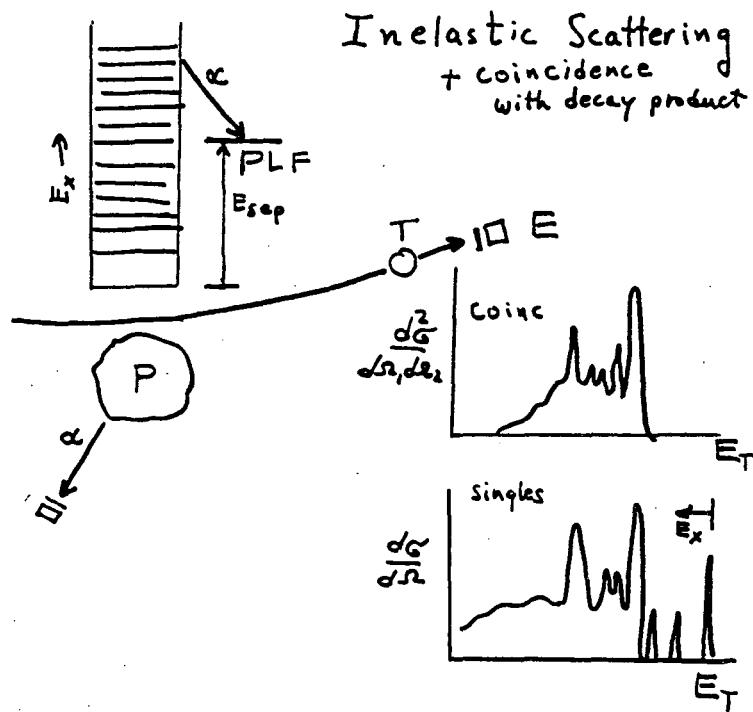

FIGURE 2. Schematic diagram of inelastic scattering spectra for a projectile T scattered by a target nucleus P. Nucleus P is excited to an unbound state that decays by α -particle emission leaving a residue nucleus, PLF.

R. G. STOKSTAD

experiment that produced the results in Fig. 1, with the participating nuclei (target, projectile) appropriately labelled for the following discussion.

If we want to do this coincidence experiment more efficiently, we may reverse the kinematics and bombard a helium target with 40 MeV per nucleon oxygen ions. The charged particles emitted by the excited ^{16}O nuclei will now be kinematically focused in the forward direction. The spectrum of excitation in ^{16}O will be determined, not by measuring the (very low) energy of the recoiling helium target nuclei but by measuring the relative kinetic energy of the charged particle and the decay product. In this way, the same spectrum as in Fig. 1a will be recovered. This is illustrated schematically in Fig. 3a. Note: The important feature is that the object whose decay we wish to study is moving with the projectile velocity in the laboratory system, and this is what we mean by "reverse kinematics". While this situation occurs, even for fusion reactions, when the projectile is much heavier than the target, it can also occur when the target is much heavier than the projectile. Thus, we use the term "reverse kinematics" quite generally here.

States in ^{16}O decay predominantly by α -particle emission. Thus, the residue of the decay is a ^{12}C nucleus that will be moving, on average, with approximately the beam velocity. The velocities of the individual ^{12}C nuclei, however, will be distributed about the average in a manner determined by the recoil imparted to them by emission of the alpha particle from the parent $^{16}\text{O}^*$ nucleus, i.e., by the population

R. G. STOKSTAD

spectrum of states excited by the inelastic scattering process. This is illustrated in Fig. 3b. Thus, the energy spectrum of ^{12}C nuclei (integrated over all α -emission angles and energies) will resemble the quasi-elastic peak of the ^{12}C projectile-like fragments seen in an inclusive spectrum. Indeed, this could be the major component of the quasi-elastic peak!

Several other observed features of projectile fragmentation or projectile breakup (the more generic

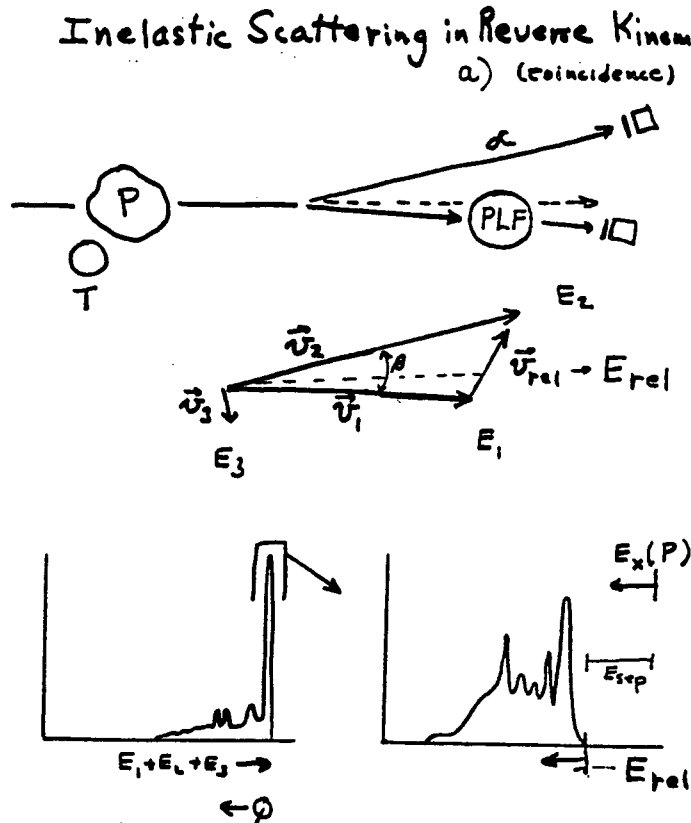

FIGURE 3a. The coincidence measurement in Fig. 2 done in reverse kinematics. The velocity diagram defines the relative kinetic energy, E_{rel} . Placing a gate on the full-energy peak yields a spectrum in E_{rel} that is equivalent to the coincidence spectrum sketched in Fig. 2.

Inelastic Scattering in Reverse Kinematics b) (Singles)

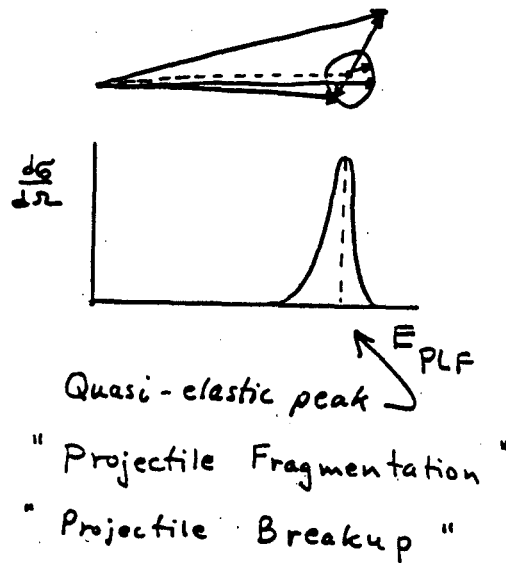

FIGURE 3b. The singles, or inclusive, spectrum of the projectile-like fragment, PLF, is recovered by integrating over all angles of emission of the α -particle. It resembles and may comprise a major fraction of the quasi-elastic peak.

term) can be understood, at least qualitatively, in terms of known characteristics of the inelastic scattering process. (i) The features of breakup are not strongly dependent on the choice of target; this is equivalent to the general insensitivity of inelastic-scattering cross sections to the type of projectile used, so long as it is strongly absorbed. ii) Breakup cross sections, relative yields and spectral features change only slowly with bombarding energy; this is because cross sections for inelastic

R. G. STOKSTAD

scattering change slowly with bombarding energy. For example, one may compare the spectrum in Fig. 1b with those in Ref. 3. obtained at 25 MeV per nucleon.

We could repeat the above illustration for transfer reactions as well, (${}^4\text{He}, t$), (${}^4\text{He}, {}^3\text{He}$), (d, α) etc., taking coincidences with the particle decay of excited target-like nuclei formed in such reactions. It follows that, in the reversed-kinematics reaction, we will have contributions to the quasi-elastic peak in which the projectile picked up nucleons from (or lost them to) the target before the excited fragment decayed by particle emission.

Thus, our experience with inelastic scattering and transfer reactions induced by light and heavy ions in normal kinematics tells us that the same processes must be contributing to what has come to be called projectile breakup and the quasi-elastic peak. This crucial point is the burden of this introduction.

Of course, even the casual reader will recognize the wisdom of hindsight--experiments with high resolution in the relative kinetic energy, sufficient to reveal the spectrum of excited states in the parent fragment, had to be performed before this perspective could be gained. When these experiments were done, one then spoke of resonant or sequential decay of the projectile rather than fragmentation. Sequential decay is now observed so frequently that it makes sense to introduce the subject of breakup from this point of view rather than to present it as a conclusion at the end of a paper.

More importantly, it should be possible to use

R. G. STOKSTAD

this perspective and to go beyond hindsight to explain, in a quantitative way, some of the existing systematics and to predict the outcome of future experiments. I will come back to this point later.

In the following, I would like to present some examples of experiments that exploit the kinematic properties of breakup reactions to study nuclear structure or to shed light on the mechanisms of peripheral heavy-ion reactions. In this limited space, it is impossible to be representative of the wide variety of experiments that have been made in many laboratories throughout the world (see Ref. 1). The following examples are experiments that were all done at LBL and, with one exception, in our group at the 88-Inch Cyclotron.

II. NUCLEAR STRUCTURE STUDIES

There are three advantages in using projectile-breakup reactions to study nuclear structure. (1) High efficiency: the decay products are focused in the forward direction. (2) High resolution: the resolution in relative kinetic energy depends on the measurement of an opening angle and, hence, can be enhanced by accurate measurement of the positions of particles as well as their energies. (3) Selectivity: in association with pickup and stripping, the particular decay channel can be used to emphasize cluster structure and/or angular momentum.

Position-sensitive detectors are the key element in the experiments.⁴⁾ They simultaneously permit high efficiency and high resolution. Such an apparatus is

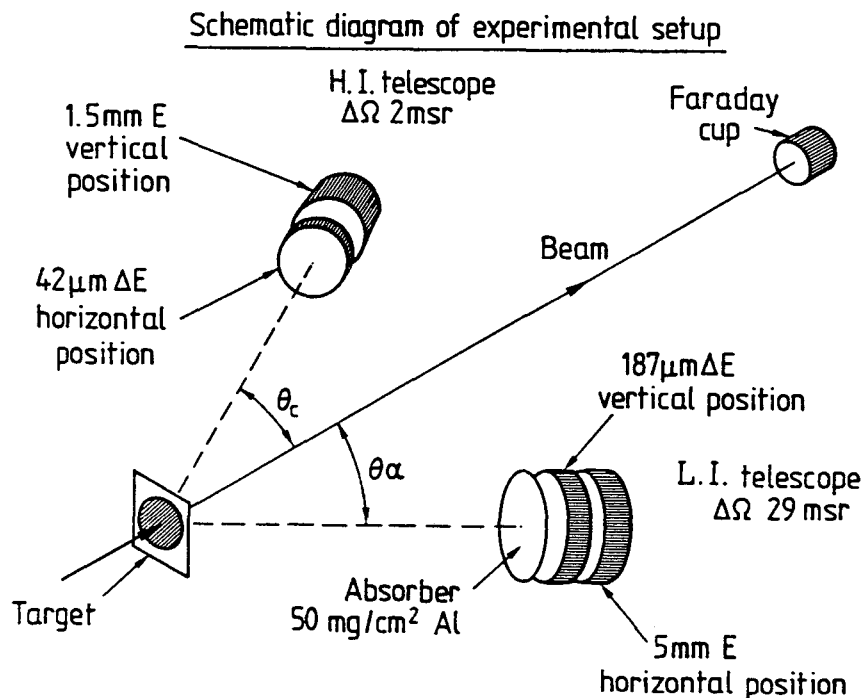

FIGURE 4. An experimental arrangement for studying breakup that incorporates position-sensitive detectors (Ref. 4).

sketched in Fig. 4, and employs ΔE -E counter telescopes that are position sensitive in both x and y coordinates. W. D. Rae, et al., used this configuration to study the reactions of ^{16}O on ^{12}C , ^{13}C and ^{28}Si targets.⁵⁾ The measurement of the positions and energies of two of the three bodies determines the total kinetic energy in the exit channel, which in turn permits one to select collisions in which all three of the reaction products are in their ground state. The spectrum of relative kinetic energy, shown in Fig. 5, is for such events ($Q_3 = Q_{\text{ggg}}$). Here one can clearly see the excited states in the parent ^{16}O nucleus.

R. G. STOKSTAD

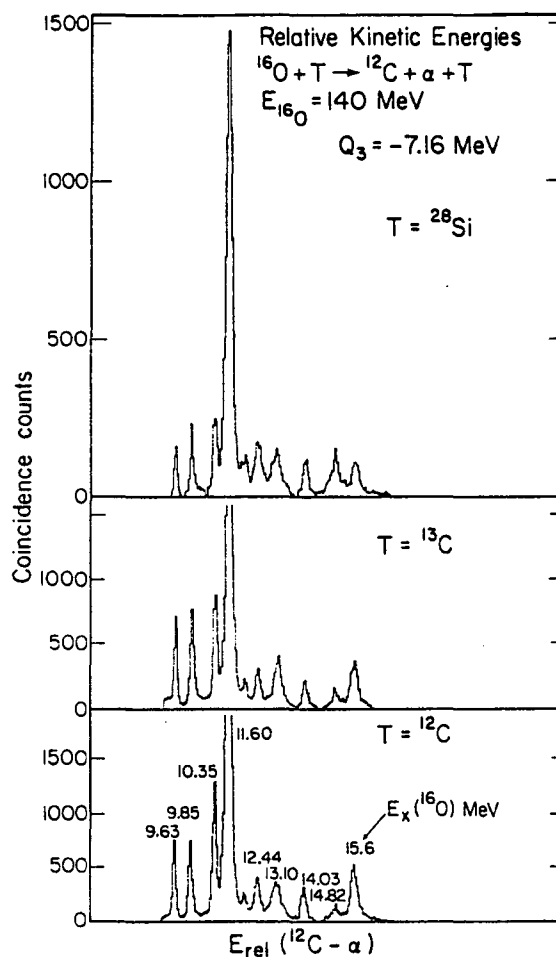

FIGURE 5. Relative kinetic energy spectra for 9 MeV/A ^{16}O on several targets (Ref. 5). The strong peak at $E^* = 11.60 \text{ MeV}$ is the same one that appears in Fig. 1.

Note that, as in Fig. 1, the 11.6 MeV state is strongly excited. The spectra in Fig. 5 correspond to those in Fig. 1b except that, instead of exciting ^{16}O with 40 MeV/A α particles, one is using 9 MeV/A ^{12}C , ^{13}C and ^{28}Si nuclei. Further examples are given in ref. 4 that illustrate, as well as inelastic scattering, triton pickup and α -particle pickup by the projectile before decaying to $^{15}\text{N} + \alpha$ and $^{16}\text{O} + \alpha$, respectively.

R. G. STOKSTAD

A recent example of using projectile breakup to study exotic nuclear structure is the $^{12}\text{C}(^{24}\text{Mg}, ^{12}\text{C}+^{12}\text{C})^{12}\text{C}$ reaction.⁶⁾ In this case we used an experimental arrangement that was similar to the one in Fig. 4 except that the ΔE detectors were positioned closer to the target and only the E detectors provided position sensitivity. The minimum and maximum opening angles between the two ^{12}C nuclei were 15° and 25° , respectively. The combined energy resolution was quite sufficient to resolve the 4.44 MeV first excited state of ^{12}C in the total-energy spectrum (Fig. 6). The bombarding energy was 15 MeV per nucleon, and the beam was ^{24}Mg in the 9^+ charge state, produced by our new ECR high-charge-state ion source.

The decay of ^{24}Mg into two ^{12}C nuclei in their ground states is an infrequent process, and this is evident in Fig. 6. Nevertheless, sufficient statistics were obtained in this one experiment to observe structure in the relative kinetic energy spectrum (Fig. 7) and to either determine or place limits on the angular momenta of the states in ^{24}Mg (Fig. 8). This is because, with ^{24}Mg as the projectile rather than the target,⁷⁾ the ^{12}C products appear in a relatively narrow angular cone in the laboratory system.

The purpose of this experiment was to populate states in ^{24}Mg via inelastic hadron scattering because such states could be expected to have a large structural overlap with the ground state of ^{24}Mg , but they would not be limited to states of spin 0 or 2, as is the case with excitation (or decay) via electromagnetic

processes. In spite of this, only states of spin 0 or 2 were found to be populated and to decay into two ground-state ^{12}C nuclei. The strongest state, at $E_x = 21.9$ MeV, was found to coincide in energy and spin with a strong state seen in the radiative capture⁸⁾ of

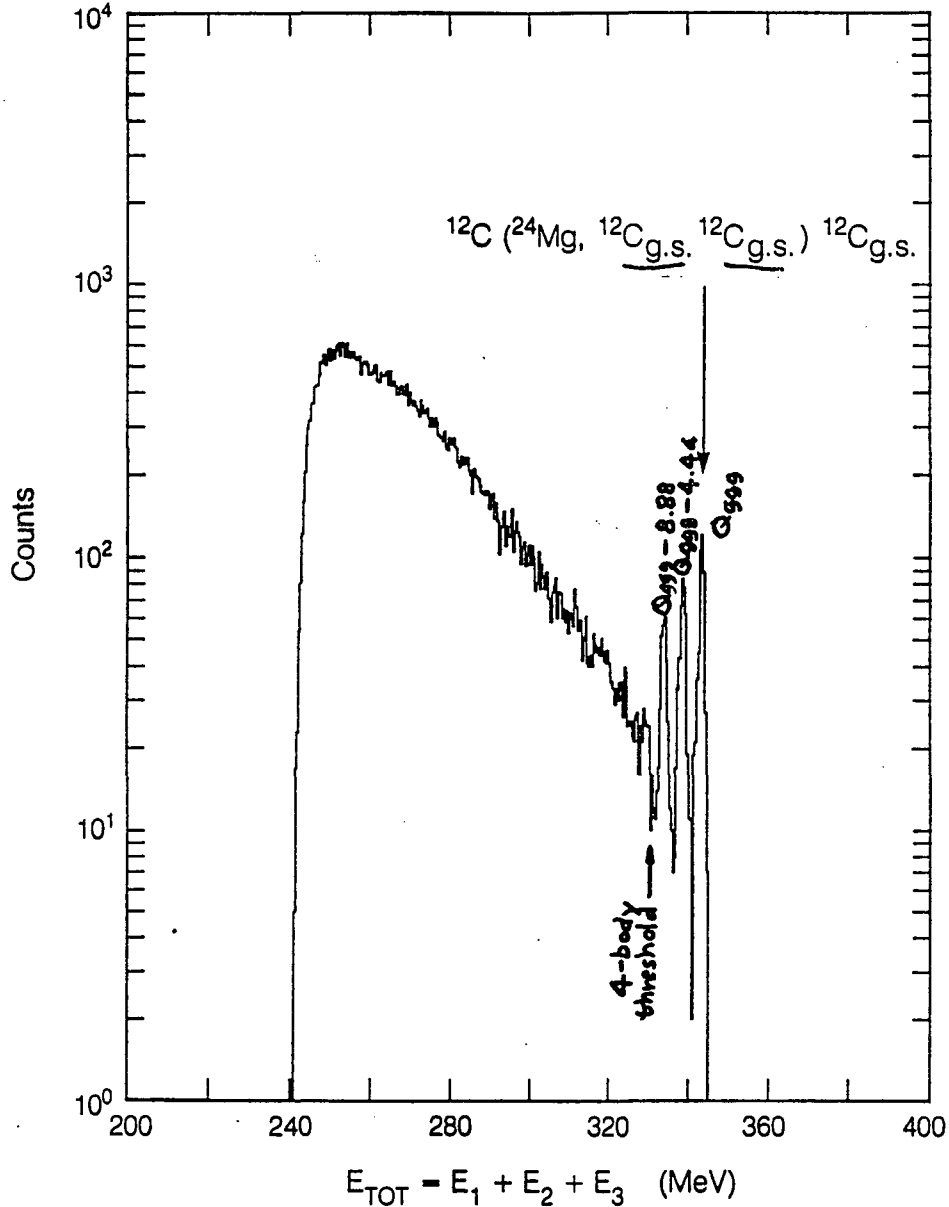

FIGURE 6. The total-energy spectrum for 15 MeV/A ^{24}Mg breaking up into two ^{12}C nuclei (Ref. 6).

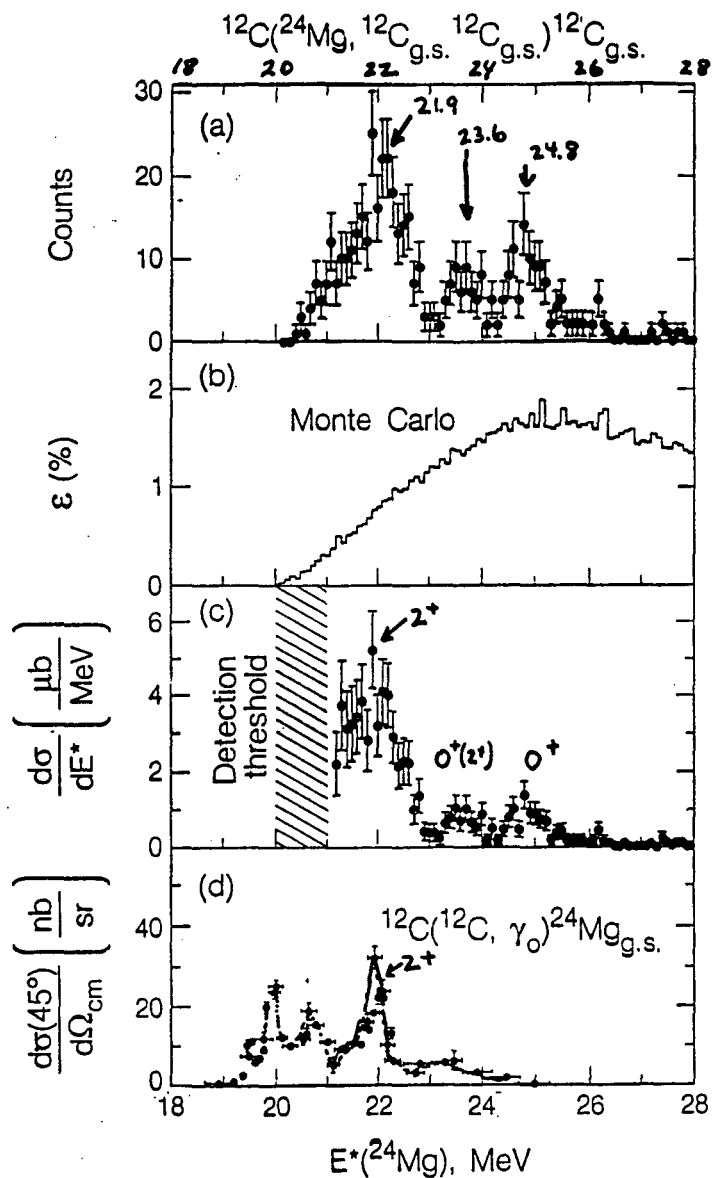

FIGURE 7. (a) Spectrum of the $^{12}\text{C}(^{24}\text{Mg}, ^{12}\text{C}_{\text{g.s.}})^{12}\text{C}_{\text{g.s.}}$ reaction as a function of the excitation energy of ^{24}Mg ; (b) Detection efficiency, ϵ , calculated with the Monte Carlo method; (c) Spectrum of Fig. 2a corrected for the energy dependence of the efficiency, ϵ ; (d) Spectrum of the radiative-capture reaction $^{12}\text{C}(^{12}\text{C}, \gamma_0)^{24}\text{Mg}_{\text{g.s.}}$, redrawn from Ref. 8.

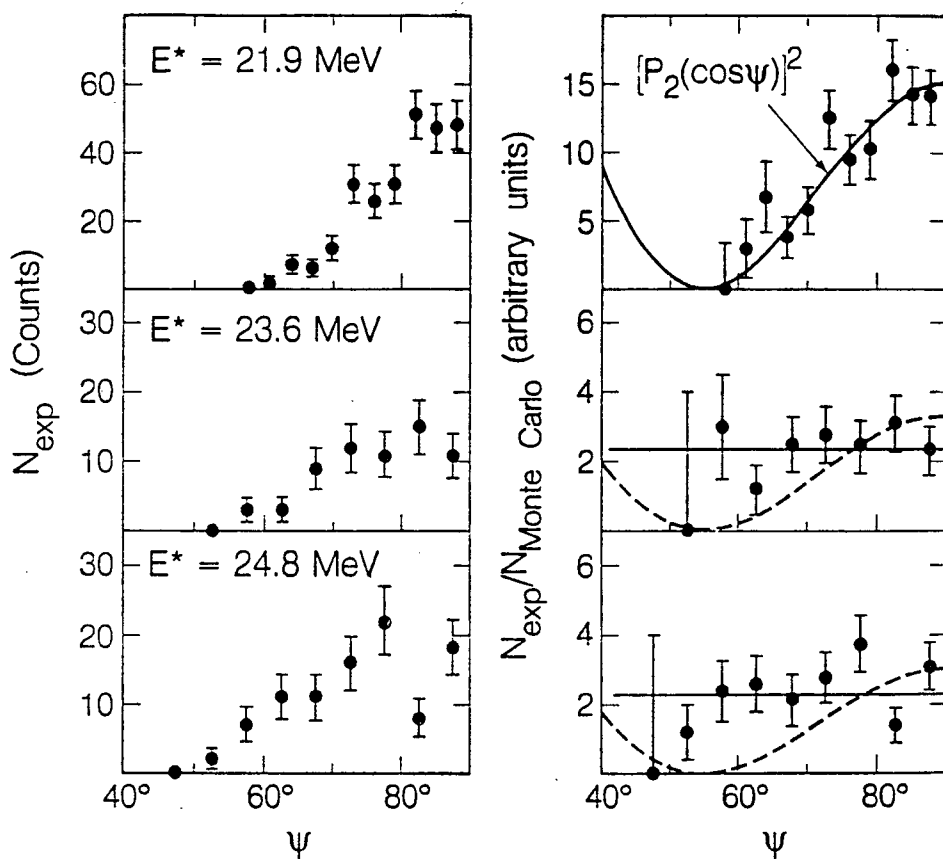

FIGURE 8. Angular distributions of the $^{12}\text{C}+^{12}\text{C}$ decay in the rest frame of $^{24}\text{Mg}^*$ for the resonance at $E^*=21.9, 23.6$ and 24.8 MeV (left). On the right hand side, the angular distributions are corrected for the dependence of the detection efficiency (calculated with the Monte Carlo method) on the decay angle ψ . The least-squares fits of the $[P_J(\cos \psi)]^2$ dependence are shown.

^{12}C by ^{12}C (Fig. 7d). The other states we see at 23.6 and 24.8 MeV excitation are either not populated, or populated only very weakly, by electromagnetic processes. The nature of these special states in ^{24}Mg is still an interesting and much discussed question.

III. REACTION MECHANISM STUDIES

The foregoing study of a projectile breaking up into two identical pieces assumed the reaction mechanism was known (inelastic scattering, sequential decay) and was undertaken to learn something about nuclear structure. In the following, we concentrate on learning more about the reaction mechanism, and take as the first example the case of ^{12}C disintegrating into two ^6Li nuclei or three alpha particles.⁹⁾ The relative

Breakup of ^{12}C by CH_2

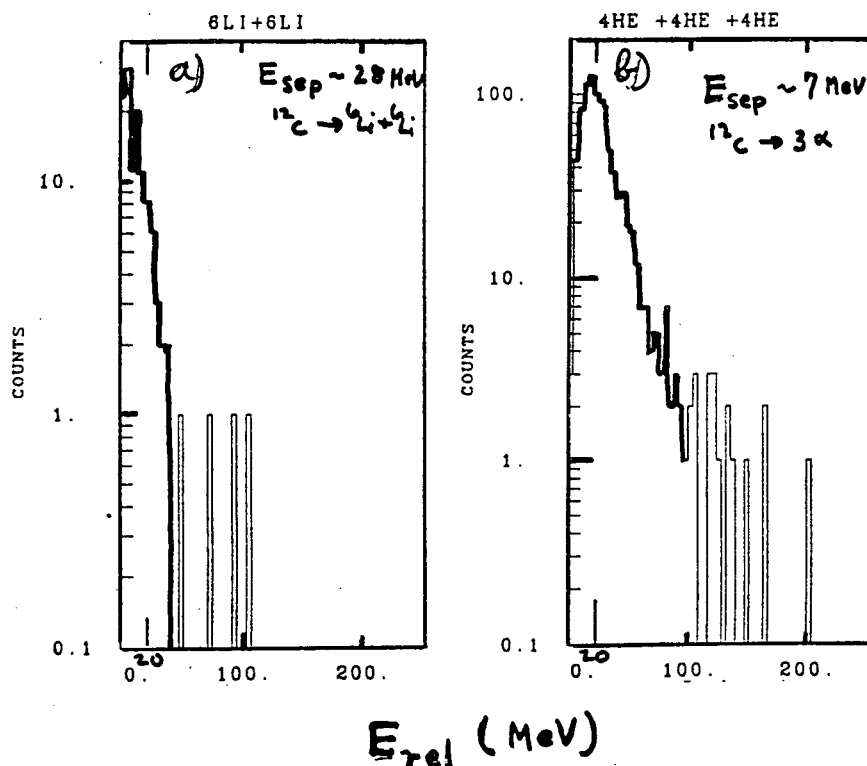

FIGURE 9. Spectra of relative kinetic energy for ^{12}C breaking into $^6\text{Li}+^6\text{Li}$ or $\alpha+\alpha+\alpha$ (Ref. 9). The excitation energies $E^* = E_{rel} + E_{sep}$ are characteristic of inelastic scattering; the bombarding energy is 2100 MeV/A.

R. G. STOKSTAD

kinetic energy of the lithium nuclei or the three alpha particles is shown in Fig. 9. In order to obtain excitation energy in ^{12}C , one must add the separation energy (28 MeV for $^6\text{Li} + ^6\text{Li}$ and 7 MeV for $\alpha + \alpha + \alpha$). The most probable excitation energies are thus of the order of 25–30 MeV, which is not that different from the other cases we have considered where we know that inelastic scattering is responsible. What is remarkable is that the projectile energy in this study was 2100 MeV per nucleon. The measurements were made at the Bevalac using the HISS (Heavy Ion Superconducting Spectrometer) facility. The target was CH_2 , and no restriction was placed on the fate of the target nucleus. However, the events were restricted to those in which all 12 nucleons in the projectile were observed to be moving forward with beam velocity (i.e., the collision was peripheral).

These results, impressive (experimentally) and surprising as they may be, are nevertheless understandable in the perspective of inelastic scattering. High-resolution studies of inelastic proton scattering¹⁰⁾ at 0.8 GeV on ^{12}C show the excitation of states in this energy region, and they will decay with some finite probability by α -particle or ^6Li emission. Of course, I do not wish to imply that this is all that happens in peripheral relativistic heavy-ion reactions. One knows the contrary. What is clear is that these high-energy peripheral reactions are producing excitation energies in the parent nucleus that are characteristic of inelastic scattering, and that one may know these characteristic energies from measurements of the inelastic scattering in the usual way, i.e. with

R. G. STOKSTAD

normal kinematics.

The same experiment that enables the measurement of the excitation energy in the object with beam velocity permits a determination of the excitation energy in the target-like, or slow moving, object. One may in this way study the partition of excitation energy in peripheral reactions. For example, if ^{20}Ne is the projectile and one observes ^{16}O in coincidence with a beam-velocity α particle, the relative energy gives the excitation energy in ^{20}Ne and the three-body Q-value (obtained from measuring the total kinetic energy in final state) determines the excitation energy in the target-like fragment. (In Figs. 5 and 7, one used this to select out those events in which this latter excitation was zero.) That is the basic idea, and it works providing one is dealing with a 3-body and not a 4- (or more) body reaction and that one knows that the projectile-like fragment (PLF), ^{16}O in our example, is in its ground state. In practice, these restrictions are satisfied approximately provided the bombarding energy is not too high and that unobserved neutron decay of the beam-velocity fragment is minimal.

Such an experiment is illustrated in Fig. 10. A segmented, position-sensitive plastic phoswich detector¹¹⁾ is used to identify protons and alpha particles, and measure their energies and positions. The PLF is detected by a solid-state telescope placed centrally and just in front of the plastic array. The reaction was 11 MeV/A ^{20}Ne on a ^{197}Au target. The right-hand panel shows the position distribution of α -particles in coincidence with ^{16}O ions in the

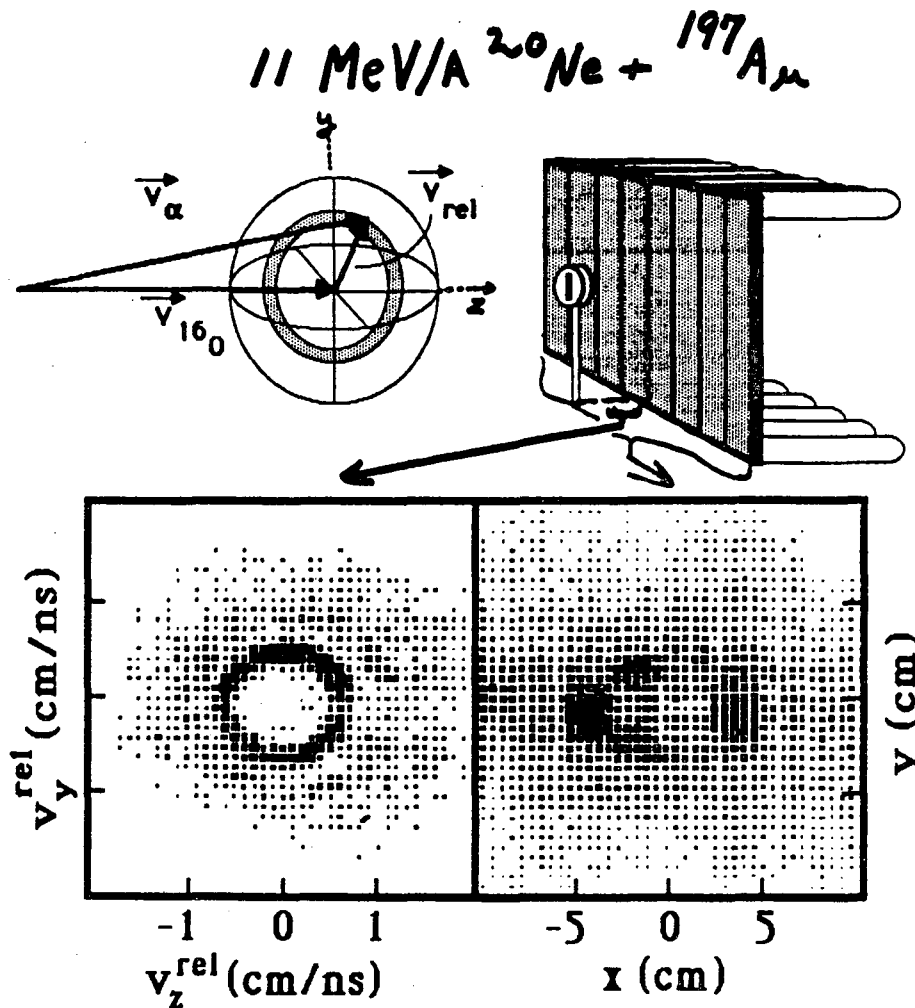

FIGURE 10. Schematic diagram of the apparatus used to study the partition of kinetic energy in peripheral reactions. The two-dimensional spectra are for coincidences between α -particles and 160 ions.

telescope, for all eight plastic slices. The velocity diagram illustrates the relationship between the relative velocity of the α -particle and 160 ion for excitation of a low-lying state in ^{20}Ne . If we take a cut through the y - z plane, the locus of points should form a ring. Experimentally, this is done by looking at coincident α -particles in a slice just behind the

detector. The data plotted in the left-hand panel show an intense ring corresponding to collective states at ~ 5.8 MeV excitation ^{20}Ne . A second ring is just visible and corresponds to states at 7 MeV excitation.

The determination of excitation energy for a primary fragment that is not the projectile is shown in Fig. 11. Here one sees the spectrum of excitation in

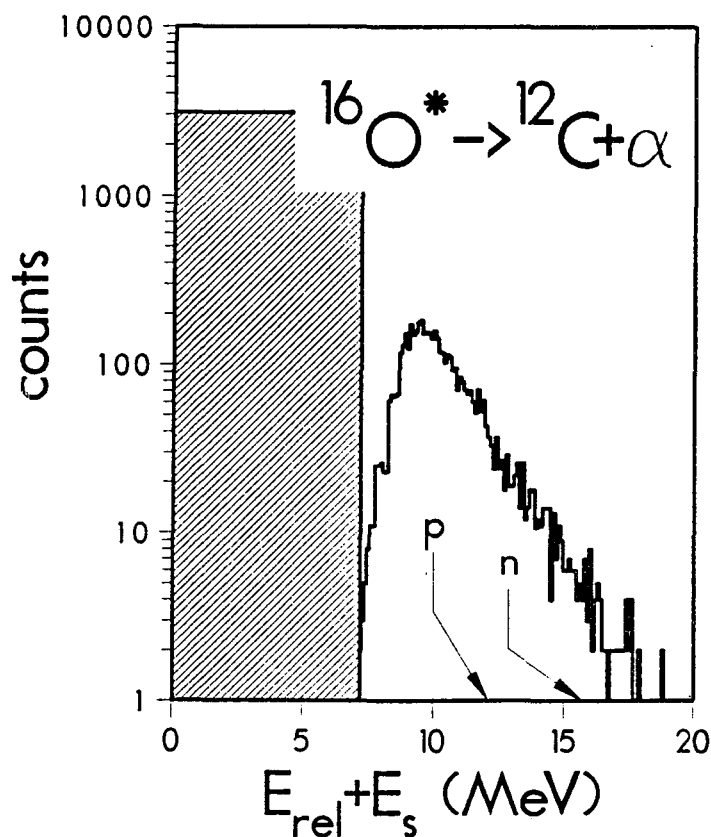

FIGURE 11. Excitation energy in the primary fragment $^{16}\text{O}^*$. The hatched area represents the yield to bound states. Note the logarithmic ordinate. No gate has been placed on the total energy.

R. G. STOKSTAD

^{16}O . The first states that α decay are at about 9 MeV excitation. The proton and neutron thresholds are indicated. Note that, even before the proton threshold is reached, the population of $^{16}\text{O}^*$ is dropping rapidly with increasing excitation. The total population of bound states is given approximately by the area of the shaded histogram. This represents the yield of ^{16}O that is in anti-coincidence with any charged particle. We can determine this because the solid angle of the light-charged-particle detector is large, and we have checked this by comparing with measurements made with our 4π detector, the plastic box.¹²⁾ The message of Fig. 11 is that the average excitation of $^{16}\text{O}^*$ is low, at or below the α -particle threshold.

The excitation energy in the target-like fragment (TLF) (again, under the assumption that the detected PLF is in its ground state) is shown in Fig. 12 for three cases. They correspond to proton pickup by the projectile, proton capture by the target, and alpha particle capture. Note how the excitation energy caused by proton capture is on the average higher than that caused by proton removal. The excitation energy in the target produced by removal of one or two neutrons is also quite low. The lower panel illustrates that the capture of an alpha particle produces much more excitation energy than capture of a proton. In these reactions (Figs. 11 and 12) no restrictions are placed on the total kinetic energy of the final products.

Thus, excitation energy is produced mainly by the capture of nucleons rather than by their removal. This is one of the important assumptions made in the

R. G. STOKSTAD

kinematic models used to predict the optimum Q-value, e.g., the model of Siemens, et al.¹⁴⁾ In Fig. 13 we compare the predictions of this model to the measured, most-probable excitation energies in the target. The trend of the experimental data is followed quite well.

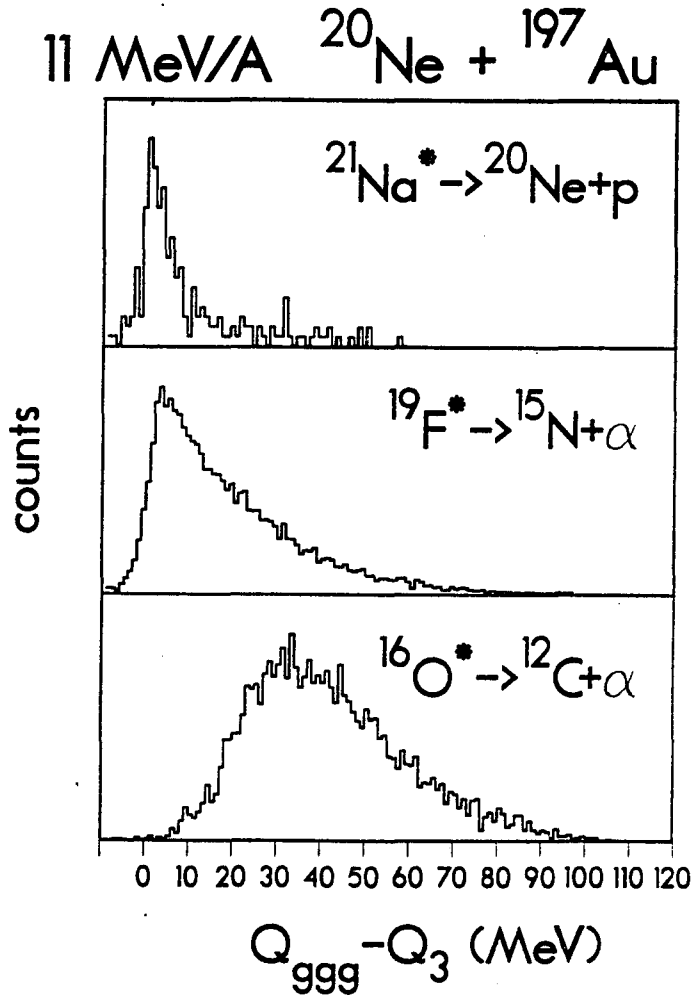

FIGURE 12. Excitation energy in the target-like fragment for proton removal, proton capture and α -particle capture.

The open circles assume that the mass transfer is in one direction only and represents the mass missing from the

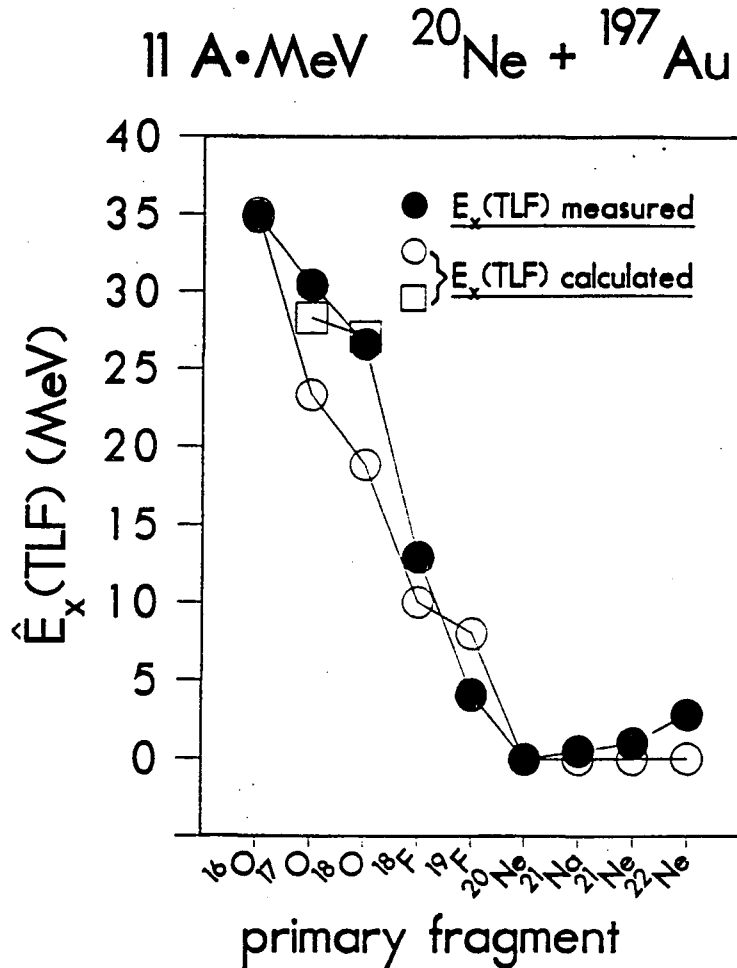

FIGURE 13. The most-probable excitation energy in the target-like fragment. Mass transfer is determined from the mass of the primary fragment. The open circles are calculated using the model of Ref. 14.

projectile. This need not be the case, as mass can be transferred in both directions. The open squares are values calculated assuming an α -capture by the target and one- or two-neutron pickup by the projectile. We have obtained qualitatively similar results at 17 MeV per nucleon.¹⁵⁾

The new ECR source at the 88-Inch Cyclotron has

R. G. STOKSTAD

enabled us to extend significantly the maximum bombarding energy for ^{16}O ions. Previously we were limited to 20 MeV/A. We have now been able to do experiments with 27 MeV/A ($^{16}\text{O}^{7+}$) and 32.5 MeV/A ($^{16}\text{O}^{8+}$), and have used a variation of the apparatus shown in Fig. 10. Here again, one sees the same type of patterns as in Fig. 10, which indicate inelastic scattering to low-lying unbound levels. However, a new feature emerges at these higher energies and it is seen in the total-energy spectrum. Figure 14 shows the Q-value spectra for $^{12}\text{C}+\alpha$ and $^{13}\text{C}+\alpha$ coincidences. Each spectrum shows a strong peak at $Q_3 = Q_{\text{ggg}}$ corresponding to all three bodies having either little or no excitation (sometimes referred to as "elastic breakup"). However, the other portions of the spectra are strikingly different. To make a long story short, the strong, broad peak in the top panel is the result of the sequential process $^{16}\text{O} \rightarrow ^{17}\text{O}^* \rightarrow n + ^{12}\text{C} + \alpha$ in which the neutron is unobserved. In the reaction $^{16}\text{O} \rightarrow ^{17}\text{O}^* \rightarrow ^{13}\text{C} + \alpha$, there is no missing energy. The broad peak also shows up in the $^{15}\text{N} + p$ coincidence channel, and it moves to higher "excitation" when the experiment is done at 32.5 MeV/A.

This type of pickup and decay process has become well known to workers attempting to study giant resonances with heavy ions. Here, it appears as a 4-body process. What is particularly interesting is that neutron pickup appears to be so strong compared to inelastic scattering of ^{16}O . Therefore, we are now studying the gross features of the single- and few-nucleon transfers (both to and from the projectile)

R. G. STOKSTAD

2.7 MeV/A $^{16}\text{O} + ^{197}\text{Au}$
(ECR source, 0^{7+})

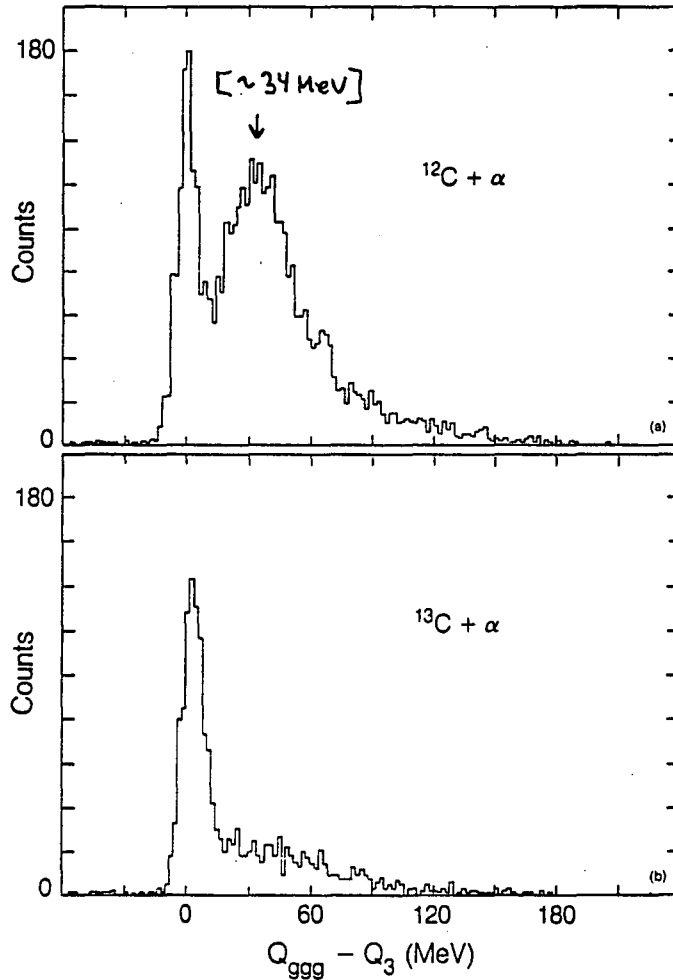

FIGURE 14. Q-value spectra for $^{12}\text{C} + \alpha$ and $^{13}\text{C} + \alpha$ coincidences at 90° . The large bump at ~ 34 MeV excitation arises from a 4-body process, neutron pickup and decay to excited states of ^{16}O , which further decay to $^{12}\text{C} + \alpha$.

as the bombarding energy approaches the Fermi energy of almost 35 MeV/A.

R. G. STOKSTAD

In summary, projectile fragmentation or breakup reactions with heavy ions can be viewed as inelastic scattering (or transfer reactions) performed in reverse kinematics. As a spectroscopic tool, it offers high resolution, efficiency and selectivity. In terms of the reaction mechanism, this process must contribute to the quasi-elastic peak observed in inclusive spectra. The only question is how much it contributes. The evidence suggests that for products within one or two α -particles removed from projectiles with $A < 20$, it is quite significant and probably dominates. It would therefore seem reasonable to attempt a description of the systematic behavior of momentum width (of the quasi-elastic peak) vs. bombarding energy in terms of this mechanism. One would incorporate all one knows from experiment (measurements of inelastic scattering in normal kinematics) and theory (DWBA, for example) and see whether this can account for the rapid rise in width between 10 MeV/A and 100 MeV/A bombarding energy.

I would like to acknowledge the significant contributions of several present and former colleagues at LBL to the experiments described here. William Rae (high-resolution spectroscopy with position sensitive detectors), Janusz and Krystyna Wilczynski(a) (the ^{24}Mg experiment), Michael Bantel (phoswich detector development), Stuart Gazes and Rudi Schmidt (excitation-energy partition) and Yuen-dat Chan (for many things). Many other people have contributed as well and I have tried to indicate this by listing all names in each of the references. I thank the members of the HISS group for permission to show their results.

R. G. STOKSTAD

It has been a pleasure as well as an honor to participate in this symposium dedicated to John Huizenga on the occasion of his 65th birthday. I hope that our science and all the people who enjoy doing it will continue to benefit from John Huizenga's scientific insight and fine human qualities for many years to come. And finally, I wish John many happy years ahead.

This work was supported by the Director, Office of Energy Research, Division of Nuclear Physics of the Office of High Energy and Nuclear Physics of the U.S. Department of Energy under Contract DE-AC03-76SF00098.

REFERENCES

1. R. G. Stokstad, Comments Nucl. Part. Phys. 13, 231 (1984).
2. T. Bauer, H. Breuer, A. Kiss, K. T. Knopfle, C. Meyer-Borricke, P. Paul, M. Rogge, and G. J. Wagner. KFA-IKP 10/76 (Julich), Ann. Report, 17 (1975).
3. M. N., Harakeh, A. R. Arends, M. J. A. deVoight, A. G. Drentje, S. Y. Van der werf, and A. Van der Woude, Nucl. Phys. A265, 189 (1986).
4. W. D. Rae, A. J. Cole, A. Dacal, R. Legrain, B. G. Harvey, J. Mahoney, M. J. Murphy, R. G. Stokstad and I. Tserruya, Phys. Lett. 105B, 417 (1981)
5. W. D. M. Rae, A. J. Cole, B. G. Harvey and R. G. Stokstad, Phys. Rev. C30, 158 (1984).
6. J. Wilczynski, K. Siwek-Wilczynska, Y. Chan, E. Chavez, S. B. Gazes and R. G. Stokstad, LBL preprint 21415.
7. J. Wilczynski, K. Van der Borg, H. T. Fortune, J. van Popta, R. H. Siemsen, K. Siwek-Wilczynska, S. Y. Van der Werf and A. van der Woude, Nucl. Phys. A334, 317 (1980).
8. A. M. Nathan, A. M. Sandorfi, and T. J. Bowles, Phys. Rev. C24, 932 (1981).
9. H. J. Crawford, J. Engelage, I. Flores, M. Baumgartner, E. Beleal, F. Bieser, M. Bronson, D. Greiner, L. Greiner, P. T. Lindstrom, C. P. Mc Parland, D. L. Olson, J. Porter, R. Wada, M. L. Webb, Bull. Am. Phys. Soc. 31, 888 (1986); P. J. Lindstrom, et al., *ibid.*

R. G. STOKSTAD

10. K. W. Jones, et al., Phys. Lett. 128B, 281 (1983); Phys Rev. C33, 17 (1986)
11. M. Bantel, R. G. Stokstad, Y. D. Chan, S. Wald and P. J. Countryman, Nucl. Inst. Meth. 226, 394 (1984); H. R. Schmidt, M. Bantel, Y. Chan, S. B. Gazes, S. Wald and R. G. Stokstad, Nucl. Inst. Meth. A242, 111 (1985).
12. H. R. Schmidt, S. B. Gazes, Y. Chan, R. Kamermans, and R. G. Stokstad, Bull. Am. Phys. Soc. 30, 1246,1280 (1985), and to be published.
13. S. Wald, S. B. Gazes, C. R. Albiston, Y. Chan, B. G. Harvey, M. J. Murphy, I. Tserruya, R. G. Stokstad, P. J. Countryman, K. Van Bibber and H. Homeyer, Phys. Rev. C32, 894 (1985).
14. P. J. Siemens, J. P. Bondorf, D. H. E. Gross, and F. Dickman, Phys. Lett. 36B, 24 (1971).
15. S. B. Gazes, E. Chavez, Y. Chan, A. Dacal, M. E. Ortiz, H. R. Schmidt, K. Siwek-Wilczynska, J. Wilczynski, and R. G. Stokstad, in preparation.

This report was done with support from the Department of Energy. Any conclusions or opinions expressed in this report represent solely those of the author(s) and not necessarily those of The Regents of the University of California, the Lawrence Berkeley Laboratory or the Department of Energy.

Reference to a company or product name does not imply approval or recommendation of the product by the University of California or the U.S. Department of Energy to the exclusion of others that may be suitable.

*LAWRENCE BERKELEY LABORATORY
TECHNICAL INFORMATION DEPARTMENT
UNIVERSITY OF CALIFORNIA
BERKELEY, CALIFORNIA 94720*