

Lawrence Berkeley National Laboratory

LBL Publications

Title

Wellbore Models GWELL, GWNACL, and HOLA User's Guide

Permalink

<https://escholarship.org/uc/item/0d09m4vz>

Authors

Aunzo, Z P

Bjornsson, G

Bodvarsson, G S

Publication Date

1991-10-01



Lawrence Berkeley Laboratory

UNIVERSITY OF CALIFORNIA

EARTH SCIENCES DIVISION

Wellbore Models GWELL, GWNACL, and HOLA

User's Guide

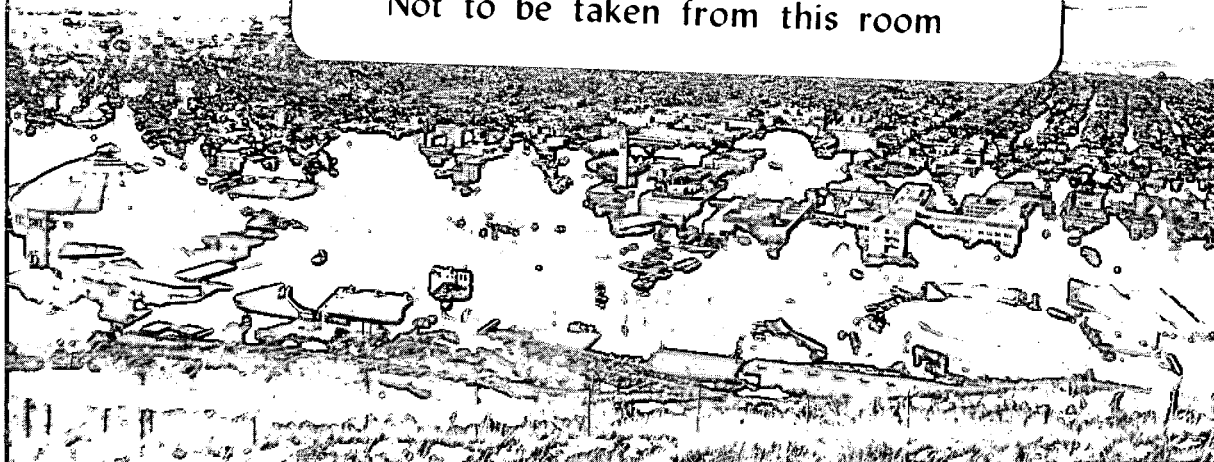
Z.P. Aunzo, G. Bjornsson, and G.S. Bodvarsson

October 1991

U. C. Lawrence Berkeley Laboratory
Library, Berkeley

FOR REFERENCE

Not to be taken from this room



DISCLAIMER

This document was prepared as an account of work sponsored by the United States Government. Neither the United States Government nor any agency thereof, nor The Regents of the University of California, nor any of their employees, makes any warranty, express or implied, or assumes any legal liability or responsibility for the accuracy, completeness, or usefulness of any information, apparatus, product, or process disclosed, or represents that its use would not infringe privately owned rights. Reference herein to any specific commercial product, process, or service by its trade name, trademark, manufacturer, or otherwise, does not necessarily constitute or imply its endorsement, recommendation, or favoring by the United States Government or any agency thereof, or The Regents of the University of California. The views and opinions of authors expressed herein do not necessarily state or reflect those of the United States Government or any agency thereof or The Regents of the University of California and shall not be used for advertising or product endorsement purposes.

This report has been reproduced directly
from the best available copy.

Available to DOE and DOE Contractors
from the Office of Scientific and Technical Information
P.O. Box 62, Oak Ridge, TN 37831
Prices available from (615) 576-8401, FTS 626-8401

Available to the public from the
National Technical Information Service
U.S. Department of Commerce
5285 Port Royal Road, Springfield, VA 22161

Lawrence Berkeley Laboratory is an equal opportunity employer.

DISCLAIMER

This document was prepared as an account of work sponsored by the United States Government. While this document is believed to contain correct information, neither the United States Government nor any agency thereof, nor the Regents of the University of California, nor any of their employees, makes any warranty, express or implied, or assumes any legal responsibility for the accuracy, completeness, or usefulness of any information, apparatus, product, or process disclosed, or represents that its use would not infringe privately owned rights. Reference herein to any specific commercial product, process, or service by its trade name, trademark, manufacturer, or otherwise, does not necessarily constitute or imply its endorsement, recommendation, or favoring by the United States Government or any agency thereof, or the Regents of the University of California. The views and opinions of authors expressed herein do not necessarily state or reflect those of the United States Government or any agency thereof or the Regents of the University of California.

Wellbore Models GWELL, GWNACL, and HOLA

User's Guide

Zosimo P. Aunzo, Grimur Bjornsson,† and
Gudmundur S. Bodvarsson‡*

*PNOC-EDC Geothermal Division, Reservoir Engineering Department
Merritt Road, Ft. Bonifacio, Metro Manila, Philippines

†National Energy Authority, Grensasvegi 9
108 Reykjavik, Iceland

‡Earth Sciences Division, Lawrence Berkeley Laboratory
University of California, Berkeley, California 94720

October 1991

This work was supported in part by the Assistant Secretary for Conservation and Renewable Energy, Office of Renewable Energy Technologies, Geothermal Technology Division, of the U.S. Department of Energy under Contract No. DE-AC03-76SF00098.



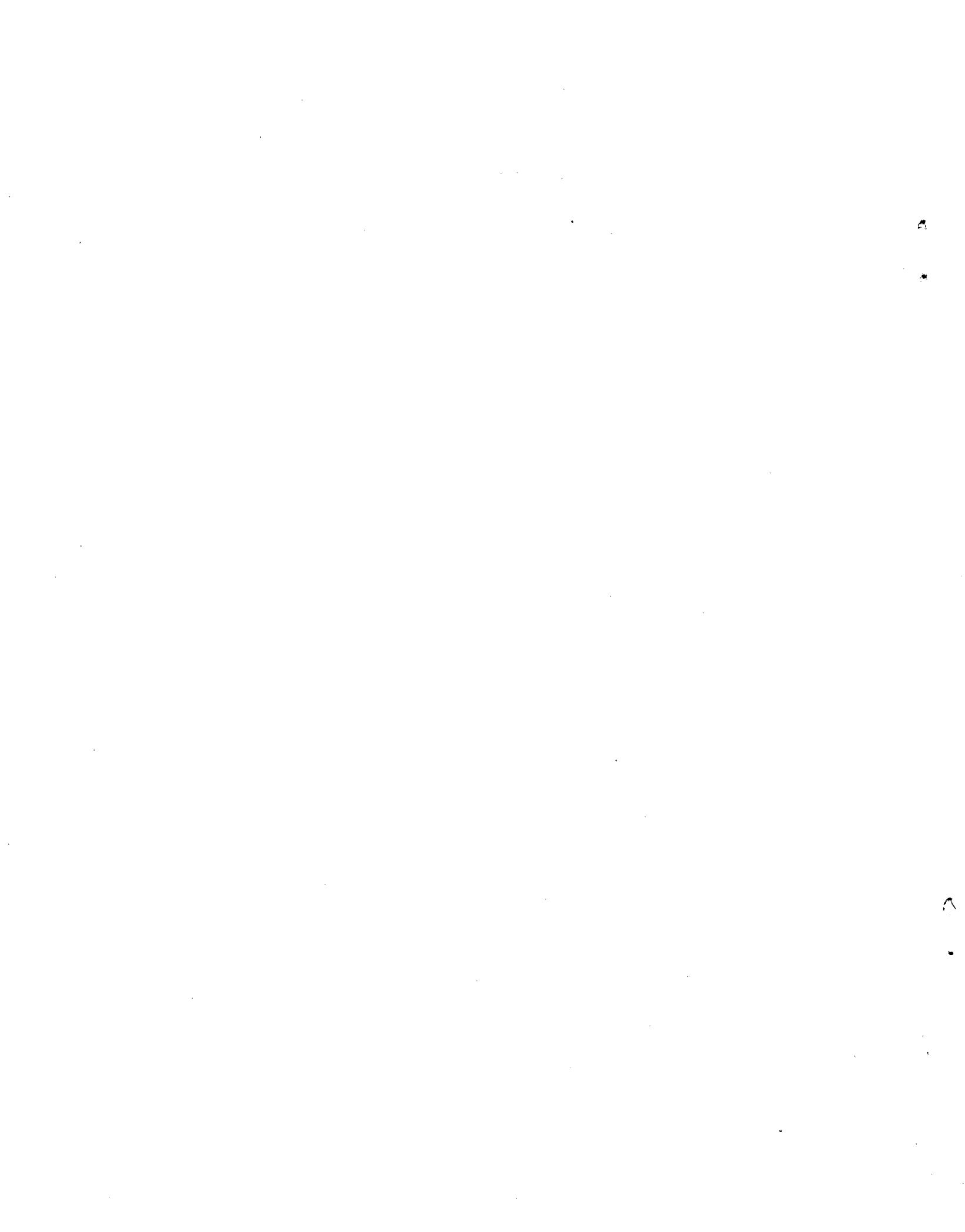
Table of Contents

List of Figures	v
List of Tables	vii
Nomenclature	ix
Acknowledgements	xiii
1.0 INTRODUCTION	1
2.0 GOVERNING EQUATIONS	2
2.1 Flow between Feedzones	2
2.2 Mass and Energy Balances at the Feedzones	5
3.0 Numerical Representations	7
3.1 Between Feedzones	7
3.2 At Feedzones	9
4.0 THEORY OF TWO-PHASE FLOW IN VERTICAL AND INCLINED PIPES	10
4.1 Introduction	10
4.2 Single Phase Flow	10
4.3 Two-Phase Flow	11
4.3.1 Basic Definitions	11
4.3.2 Description and Determination of Flow Regimes	12
4.3.3 Pressure Drop due to Friction	15
4.3.3.1 Vertical Pipes	15
4.3.3.2 Inclined Pipes	17
4.3.4 Velocities of Individual Phases	17
4.3.4.1 Armand Correlation	18
4.3.4.2 Orkiszewski Correlation	18
5.0 Equations of State	21
5.1 Water-Carbon Dioxide System (CO ₂ -H ₂ O)	21
5.1.1 Criteria for Determining the State of the Fluid	22
5.1.1.1 All-Liquid Solution of CO ₂ and H ₂ O	21
5.1.1.3 All-Gas	22
5.1.2 Partitioning of CO ₂ between Liquid and Gas Phase	22

5.1.2.1 Solubility of CO ₂ in Water	22
5.1.2.2 Mass Fraction CO ₂ in Gas	23
5.1.3 Density	24
5.1.3.1 Carbon Dioxide (CO ₂)	24
5.1.3.2 Mixtures	25
5.1.3.2.1 Liquid	25
5.1.3.2.2 Gas	26
5.1.4 Enthalpy	26
5.1.4.1 Carbon Dioxide (CO ₂)	26
5.1.4.2 Heat of Solution	27
5.1.4.3 Enthalpy of the Mixture	27
5.1.5 Viscosity	28
5.1.5.1 Carbon Dioxide (CO ₂)	28
5.1.5.2 Mixture	28
5.1.6 Surface Tension	28
5.2 Water-Sodium Chloride System (H ₂ O-NACL)	29
5.2.1 Criteria for Determining the State of the Fluid	30
5.2.1.1 Single-Phase Liquid	30
5.2.1.2 Two-Phase	30
5.2.1.3 Single-Phase Gas	30
5.2.2 Solubility of NACL in Water	30
5.2.3 Saturation Temperature	31
5.2.4 Saturation Pressure	31
5.2.5 Density	32
5.2.6 Enthalpy	34
5.2.7 Viscosity	34
5.2.8 Surface Tension	35
6.0 DESCRIPTION OF THE SIMULATOR	38
6.1 Overview of Program Structure and Execution	38
6.2 Input Data	42
6.3 Output	42
6.4 Additional Notes on Running the Program	43
References	48
Figures	54
Appendix A (Sample Runs for GWELL)	62
Appendix B (Sample Runs for GWNACL)	74
Appendix C (Sample Runs for HOLA)	86

List of Figures

Figure	Description	Page No.
2.1	Possible flow configurations that can occur at a feedzone (modified after Bjornsson, 1987)	55
4.1	Illustration of the different flow regimes (after Orkiszewski, 1967)	56
5.1	Saturation curve for H ₂ O (after Pritchett et al., 1981)	57
5.2	Saturation curve for H ₂ O-CO ₂ system with 1% CO ₂ (after Pritchett et al., 1981)	58
5.3	Effect of CO ₂ on the surface tension of H ₂ O at different temperatures	59
5.4	Saturation curve for H ₂ O-NaCl system (after Haas, 1976)	60
6.1	Simplified flowchart	61



List of Tables

Figure	Description	Page No.
4.1	Flow Regimes and Criteria	15
4.2	Values of B_s for Smooth Pipes	17
4.3	Equations for the Armand Coefficient	19
5.1	Values of Coefficients for Calculation of CO_2 Solubility	23
5.2	Values of Coefficients for Calculation of CO_2 Density	25
5.3	Values of Coefficients for Calculation of CO_2 Viscosity	29
5.4	Values of AA Coefficients for Calculation of Brine Enthalpy	36
5.5	Values of BB Coefficients for Calculation of Vapor Enthalpy	36-37
6.1	Description of the Subroutines	38-39
6.2	Option 1 Input Deck	44
6.3	Option 2 Input Deck	45
6.4	Description of the Input Variables	46-47

NOMENCLATURE

A	=	cross-sectional area, m ²
B _R	=	semi-empirical coefficient for calculating the two-phase multiplier
B _s	=	semi-empirical coefficient for calculating the two-phase multiplier
D	=	depth of node, m
C _A	=	Armand coefficient
C _{Ah}	=	Armand coefficient for horizontal pipes
C _{Av}	=	Armand coefficient for vertical pipes
E _t	=	total energy flux, J/s
f	=	friction factor
F ₁	=	non-linear function 1 in variable y = (y ₁ , y ₂)
F ₂	=	non-linear function 2 in variable y = (y ₁ , y ₂)
G	=	mass flux, kg/m ² -s
g	=	gravity constant, m/s ²
H	=	enthalpy, kJ/kg
k	=	intrinsic permeability, m ²
k _r	=	liquid relative permeability, m ²
k _{rV}	=	gas relative permeability, m ²
k	=	fluid incompressibility, Pa
K	=	gas to liquid velocity ratio
L	=	depth coordinate, m
L _B	=	empirical variable described in Table 4.1
L _M	=	empirical variable described in Table 4.1
L _s	=	empirical variable described in Table 4.1
L _w	=	total length of the well, m
m	=	mass flow, kg/s

\vec{m}	=	mass flow vector, kg/s
M	=	Jacobian matrix
MW	=	molecular weight
n	=	Blasius exponent
\mathbf{p}	=	vector (P_1, P_2) which makes $F_1(\mathbf{p}) = F_2(\mathbf{p}) = 0$
ρ	=	density, kg/m ³
P	=	pressure, Pa-abs
P_b	=	pressure, Bar-abs
P_r	=	reservoir pressure, Pa-abs
$P_s(T)$	=	saturation pressure for pure water at a given temperature (Pa)
P_w	=	flowing well pressure, Pa-abs
q	=	mass flow from Darcy's Law, kg/s
Q	=	volumetric flow rate, m ³ /s
Q_t	=	ambient heat flux, W/m
r	=	radius, m
r_w	=	well radius, m
R	=	universal gas constant, erg/g-°K
Re	=	Reynold's number
S	=	gas saturation
t	=	time, s
T	=	temperature, °C
T_K	=	temperature, °K
\bar{T}_r	=	mean reservoir temperature, °C
\bar{T}_w	=	mean fluid temperature, °C
u	=	average velocity, m/s
u_b	=	bubble velocity, m/s

u_{CH}	=	choked velocity, m/s
u_H	=	homogeneous velocity, m/s
u_T	=	Taylor bubble (slug) velocity, m/s
v	=	specific volume, cm^3/g
v_c	=	specific volume of water at the critical point, cm^3/g
\bar{v}_o	=	specific volume of pure water, cm^3/g
v_{gD}	=	empirical variable described in Table 4.1
x	=	mass fraction of gas
$z(P_b, T_K)$	=	CO_2 compressibility factor
$\left[\frac{dP}{dL} \right]_{acc}$	=	pressure drop component due to acceleration, Pa/m
$\left[\frac{dP}{dL} \right]_{fri}$	=	pressure drop component due to friction, Pa/m
$\left[\frac{dP}{dL} \right]_{pot}$	=	pressure drop component due to gravity, Pa/m
$\left[\frac{dP}{dL} \right]_{GO}$	=	pressure drop component if fluid flows as liquid only, Pa/m
$\left[\frac{dP}{dL} \right]_{LO}$	=	pressure drop component if fluid flows as gas only, Pa/m
α	=	mass fraction of component 2 (i.e. CO_2 , NaCl)
μ	=	dynamic viscosity, kg/m-s
ϕ_{FLO}	=	two-phase multiplier
σ	=	surface tension, N/m
β	=	gas volumetric flow rate ratio
ϵ	=	pipe roughness, m
η	=	Euler's constant

τ	=	rock thermal conductivity
Θ	=	inclination angle from horizontal, °
Ω	=	thermal diffusivity, m ² /s
Ω	=	thermal conductance, W/m-°C
Σ	=	productivity index, m ³
Γ	=	physical property parameter (see Equation 4.25)
Δ	=	finite difference

Subscripts

CO ₂	=	Carbon Dioxide (CO ₂)
f	=	feedzone
g	=	gas
H ₂ O	=	water
i	=	lower grid node
i-1	=	upper grid node
l	=	liquid
lCO ₂	=	CO ₂ in liquid
m	=	mixture
mnacl	=	molal salt concentration
nacl	=	salt (NaCl)
r	=	reservoir
s	=	steam
soln	=	solution
v	=	vapor
vCO ₂	=	CO ₂ in vapor (gas)
w	=	well
y	=	component (total, H ₂ O, CO ₂ , NaCl)

ACKNOWLEDGEMENTS

The primary author wishes to thank the management of PNOC-EDC for the support extended throughout the course of this project and especially during the final preparation of this report. Special thanks are due to the whole Reservoir Engineering Staff of PNOC-EDC who helped with the debugging and validation of the codes. Technical review of this work by M. J. Lippmann and C. H. Lai is appreciated. This work was partially supported by the Assistant Secretary of Conservation and Renewable Energy, Office of Renewable Energy Technologies, Geothermal Technology Division, of the U.S. Department of Energy under Contract No. DE-AC03-76SF00098.

1.0 INTRODUCTION

This report describes three multi-component, multi-feedzone geothermal wellbore simulators developed. These simulators reproduce the measured flowing temperature and pressure profiles in flowing wells and determine the relative contribution, fluid properties (e.g. enthalpy, temperature) and fluid composition (e.g. CO₂, NaCl) of each feedzone for a given discharge condition.

The three related wellbore simulators that will be discussed here are HOLA, GWELL and GWNACL. HOLA is a multi-feedzone geothermal wellbore simulator for pure water, modified after the wellbore simulator developed by Bjornsson, 1987 and can now handle deviated wells. The other two simulators GWELL (see also Aunzo, 1990) and GWNACL are modified versions of HOLA that can handle H₂O-CO₂ and H₂O-NaCl systems, respectively.

These simulators can handle both single and two-phase flows in vertical and inclined pipes and calculate the flowing temperature and pressure profiles in the well. The simulators solve numerically the differential equations that describe the steady-state energy, mass and momentum flow in a pipe. The codes allow for multiple feedzones, variable grid spacing and well radius. These codes were developed using FORTRAN language on the UNIX system.

2.0 GOVERNING EQUATIONS

The flow of fluid in a geothermal well can be represented mathematically by two sets of equations. Between the feedzones, the flow can be represented by one-dimensional steady-state momentum, energy and mass flux balances. When a feedzone is encountered, mass and energy balances between the fluid in the well and the feedzone are performed. The solutions of these equations require fully defined flow conditions at one end of the system (inlet condition), and fully defined boundaries (wellbore geometry, lateral mass and heat flow). The governing equations are then solved in small finite steps along the pipe. Whenever a feedzone is encountered, the mass and energy of inflow (or outflow) are given and mass and energy balances are performed, allowing the calculation to continue farther in the well.

2.1 FLOW BETWEEN FEEDZONES

The governing equations describing the flow characteristics of fluid inside a pipe can be described as follows,

Mass Balance

$$\frac{d\dot{m}_y}{dL} = 0, \quad y = \text{total, CO}_2, \text{ H}_2\text{O, NaCl} \quad (2.1)$$

where,

\dot{m} = mass flow

L = length of pipe

Momentum Balance

The total pressure gradient is the sum of the friction gradient, acceleration gradient and potential gradient (head). This can be expressed as,

$$\frac{dP}{dL} - \left[\frac{dP}{dL} \right]_{\text{fri}} - \left[\frac{dP}{dL} \right]_{\text{acc}} - \left[\frac{dP}{dL} \right]_{\text{pot}} = 0 \quad (2.2)$$

where,

$$\begin{aligned} \left[\frac{dP}{dL} \right]_{\text{fri}} &= \phi_{\text{FLO}}^2 \left[-\frac{dP}{dL} \right]_{\text{LO}} \\ \left[\frac{dP}{dL} \right]_{\text{acc}} &= \frac{d(Gu_m)}{dL} \\ \left[\frac{dP}{dL} \right]_{\text{pot}} &= \rho g \sin\Theta \end{aligned}$$

$\left[\frac{dP}{dL} \right]_{\text{LO}}$ is the pressure drop for a flowing single-phase liquid and ϕ_{FLO}^2 is the two-phase multiplier, both of which are defined in Chapter 4. G is the mass velocity, u_m is the average fluid velocity, g is the acceleration constant and Θ is the well deviation angle from horizontal, and ρ is the fluid density. The calculations of the individual components of the pressure drop equation are discussed in Chapter 4.

Energy Balance

$$\frac{dE_t}{dL} \pm Q_t = 0 \quad (2.3)$$

where,

$$\begin{aligned} E_t &= \text{total energy flux in the well} \\ Q_t &= \text{ambient heat loss/gain over a unit distance} \end{aligned}$$

The total heat flux gradient, $\frac{dE_t}{dL}$ is the sum of the discharges in the heat content of the fluid, kinetic and potential energy. This can be expressed as,

$$\frac{dE_t}{dL} = \dot{m} \frac{d}{dL} \left[h_m + 0.5u_m^2 + g(L_w - D) \right] \quad (2.4)$$

where,

$$\begin{aligned} \dot{m} &= \text{total mass flow} \\ h_m &= \text{enthalpy of the mixture} \\ u_m &= \text{average fluid velocity} \\ g &= \text{acceleration constant} \\ L_w &= \text{total measured length of the well} \\ D &= \text{measured depth} \end{aligned}$$

The ambient heat flux, Q_t in Equation (2.3) is calculated from the heat conduction equation, representing heat exchange with the rocks surrounding the well,

$$\frac{1}{r} \frac{\delta}{\delta r} \left[r \frac{\delta T}{\delta r} \right] = \frac{1}{\rho} \frac{\delta T}{\delta t} \quad (2.5)$$

where,

- T = temperature
- r = radial distance from the well
- ρ = rock thermal diffusivity
- t = time

The above equation is evaluated assuming that at the well, r_w , the temperature is equal to the wellbore fluid temperature, T_w , and far from the well, the temperature is equal to the reservoir temperature, T_∞ , such that,

$$\begin{aligned} T(r_w, t) &= T_w \\ T(r, 0) &= T_\infty \\ T(\infty, t) &= T_\infty \end{aligned}$$

An approximate solution can be obtained which is valid when the term $\rho t / r_w^2 \gg 1$ (Carslaw and Jaeger, 1959).

$$Q_t \approx 4\tau\pi(T_w - T_r) \left[\ln \left[\frac{4\rho t}{r_w^2} - 2\eta \right] \right]^{-1} \quad (2.6)$$

where,

- η = 0.577216... (Euler's constant)
- τ = rock thermal conductivity
- ρ = rock thermal diffusivity

Equation (2.6) is only an approximate solution and does not take into account transient changes in temperature when the well is discharging. Additional heat losses due to convection in the vicinity of the wellbore are also neglected. However, the term $\frac{dE}{dt}$ in Equation (2.4) is usually much larger than Q_t , and therefore the approximate solution is reasonable.

2.2 MASS AND ENERGY BALANCES AT THE FEEDZONES

Assuming that instantaneous mixing occurs between the fluid inside the wellbore and the feedzone fluid, and that mixing occurs at the wellbore pressure, then the mass and energy balances can be expressed as,

Mass Balance

(a) Total Mass

$$\dot{m}_m = \dot{m}_w - \dot{m}_f \quad (2.7)$$

(b) Component 1 (H₂O)

$$\dot{m}_m(1-\alpha_m) = \dot{m}_w(1-\alpha_w) - \dot{m}_f(1-\alpha_f) \quad (2.8)$$

(c) Component 2 (CO₂ or NaCl)

$$\dot{m}_m\alpha_m = \dot{m}_w\alpha_w - \dot{m}_f\alpha_f \quad (2.9)$$

where,

\dot{m} = massflow (vectors are used since flow can assume two directions)

α = total mass fraction of component 2

subscripts m, w and f stand for mixture, well and feedzone, respectively.

The flow from the feedzone can be specified by the user either as input parameter or the code can compute the flowrate using productivity indices for each feedzone. In the latter case, the feedzone flowrate can be calculated using Darcy's Law,

$$q = kA \left[\frac{k_{r1} P_1}{\mu_1} + \frac{k_{rv} P_v}{\mu_v} \right] \left[\frac{dP}{dr} \right] \quad (2.10)$$

where,

q = mass flow

A = area for flow

k = intrinsic permeability

k_{r1} = relative permeability to liquid

- k_{rv} = relative permeability to vapor
- μ_l = viscosity of liquid
- μ_v = viscosity of vapor
- ρ_l = density of liquid
- ρ_v = density of vapor
- $\frac{dP}{dr}$ = pressure gradient

and,

$$k_{rv} = S \quad (2.11)$$

$$k_{rl} = 1 - S \quad (2.12)$$

where,

$$S = \text{saturation}$$

Energy Balance

$$\dot{m}_m H_m = \dot{m}_w H_w - \dot{m}_f H_f \quad (2.13)$$

where, H = fluid enthalpy as described in Chapter 4

The mass flow in the well can have two possible directions: upward (when the well is producing) and downward (when the well is under injection). Similarly, the flow from the feedzone has two possible directions: towards the well (producing) and towards the reservoir (injecting). Thus, there are six possible flow configurations that can occur in the well. These six possible configurations are shown schematically in Figure 2.1.

3.0 NUMERICAL REPRESENTATIONS

The governing differential equations shown in Chapter 2.0 can be solved numerically by discretizing the well into finite size grid blocks. The numerical representations of these equations are given below.

3.1 BETWEEN FEEDZONES

The total pressure drop can be expressed as:

$$\frac{P_i - P_{i-1}}{\Delta L} - \left[\frac{\Delta P}{\Delta L} \right]_{fri} - \left[\frac{\Delta P}{\Delta L} \right]_{acc} - \left[\frac{\Delta P}{\Delta L} \right]_{pot} = 0 \quad (3.1)$$

and

$$\frac{E_{ti} - E_{ti-1}}{\Delta L} \pm Q_t = 0 \quad (3.2)$$

The subscripts i and $i-1$ refer to the lower and upper grid nodes, respectively, at a distance L apart. The components of the total pressure drop can be expressed as,

$$\left[\frac{\Delta P}{\Delta L} \right]_{acc} = \frac{(Gu_m)_{i-1} - (Gu_m)_i}{\Delta L} \quad (3.3)$$

$$\left[\frac{\Delta P}{\Delta L} \right]_{pot} = \frac{(P_{mi-1} \sin\theta_{i-1} + P_{mi} \sin\theta_i) g}{2} \quad (3.4)$$

$$\left[\frac{\Delta P}{\Delta L} \right]_{fri} = \frac{\left[\frac{\Delta P}{\Delta L} \right]_{i-1} + \left[\frac{\Delta P}{\Delta L} \right]_i}{2} \quad (3.5)$$

The total energy flux at any cross-section in the well is the sum of the heat content of the fluid, the kinetic energy and potential energy.

$$E_{ti} = \dot{m}_i [H_m + 0.5 (xu_v^2 + (1-x)u_1^2 + g(L_w - D)]_i \quad (3.6)$$

Equations (3.1) and (3.2) give two non-linear equations in terms of two independent variables. In the single-phase region, for all the three simulators, the primary variables chosen are temperature and pressure. However, in the two-phase region, pressure and mass fraction of vapor (gas), x , are chosen as the primary variables for the simulators HOLA and GWNACL. However, unlike for pure water

where the two-phase region falls on a single saturation curve, the two-phase region in the H₂O-CO₂ system is bounded by a P_{max} and P_{min} (see Figure 5.2). In this case, using temperature and pressure instead of pressure and mass fraction of vapor (gas), x , is computationally more efficient for the simulator GWELL.

Consider Equations (3.1) and (3.2) as twice differentiable and continuous functions $F_1(y)$ and $F_2(y)$ for two variables P_1 and P_2 . A solution $P=(P_1, P_2)$ which makes $F_1(P)=F_2(P)=0$ can be obtained by first guessing $y = y^* = y(y_1^*, y_2^*)$. A new iterative value of y is given by,

$$\begin{bmatrix} y_1 \\ y_2 \end{bmatrix} = \begin{bmatrix} y_1^* \\ y_2^* \end{bmatrix} - M^{-1} \begin{bmatrix} F_1(y^*) \\ F_2(y^*) \end{bmatrix} \quad (3.7)$$

where M is the Jacobian matrix:

$$M = \begin{bmatrix} \frac{\delta F_1(y^*)}{\delta y_1} & \frac{\delta F_1(y^*)}{\delta y_2} \\ \frac{\delta F_2(y^*)}{\delta y_1} & \frac{\delta F_2(y^*)}{\delta y_2} \end{bmatrix} \quad (3.8)$$

If a solution P exists and all the first and second derivatives of F_1 and F_2 are bounded, then y will converge quadratically to P .

The derivatives inside the Jacobian matrix are discretized as follows,

$$\frac{\delta F_1(y_1^*, y_2^*)}{\delta y_1} = \frac{F_1(y_1^* + y_1, y_2^*) - F_1(y_1^*, y_2^*)}{y_1} \quad (3.9)$$

where,

$$y_1 = \text{a small fraction of } y_1^*$$

Also, the thermal conductance for each node is calculated as,

$$\Omega = 4\tau\pi \left[\ln \left[\frac{4\eta t}{r_w^2} - 2\eta \right] \right]^{-1} \quad (3.10)$$

The heat loss, Q , can then be computed as,

$$Q = \Omega (\bar{T}_w - \bar{T}_r) \quad (3.11)$$

where,

\bar{T}_w = mean fluid temperature between two adjacent nodes

\bar{T}_r = mean reservoir temperature between two adjacent nodes

3.2 AT FEEDZONES

If a feedzone exists at, say node i , the thermodynamic properties of the mixture are calculated assuming an imaginary node, m , where mixing occurs simultaneously at a pressure equal to the pressure of node i . The mass flow, enthalpy and composition of the mixture are then evaluated using Equations (2.7), (2.8) and (2.9) (see Chapter 2.0).

Flow from or into the feedzone can be evaluated by expressing Equation (2.10) as follows,

$$\dot{m}_f = \frac{kA}{r} \left[\frac{k_{r1} P_1}{\mu_1} + \frac{k_{rv} P_v}{\mu_v} \right] (P_r - P_w) \quad (3.12)$$

P_r and P_w are the pressures in the reservoir and well, respectively, and r is the distance to the reservoir at P_r . The parameter kA/r can be lumped together to form a group called the *Productivity Index*, Σ . The Equation (2.23) can be expressed as,

$$\dot{m}_f = \Sigma \left[\frac{k_{r1} P_1}{\mu_1} + \frac{k_{rv} P_v}{\mu_v} \right] (P_r - P_w) \quad (3.13)$$

It should be noted that the above definition of the Productivity Index, Σ , is not the same as that used in the petroleum industry.

4.0 THEORY OF TWO-PHASE FLOW IN VERTICAL AND INCLINED PIPES

4.1 INTRODUCTION

The problem of accurately predicting pressure drop in two-phase flow is difficult since, two-phase flows are complex and difficult to analyze even for limited conditions studied. Under some conditions, the gas moves at a much higher velocity than the liquid. Also, the liquid velocity along the pipe wall can vary appreciably over a short distance and result in a variable friction loss. Under other conditions, the liquid is almost completely entrained in the gas and has very little effect on the wall friction loss. The difference in velocity and the geometry of the two phases strongly influence pressure drop. These factors provide the basis for categorizing two-phase flows (Orkiszewski, 1967).

In two-phase flows, it is customary to treat the flow of liquid and gas separately using the well established theory of single-phase flow. These equations are then extended for two-phase flows using empirical correlations. Here, these empirical equations are taken from Chisholm (1983). The notations used and the presentation of the equations are patterned after Bjornsson (1987).

4.2 SINGLE PHASE FLOW

The flow of single-phase fluid in pipes is treated extensively in fluid mechanics literature. The flow calculations are carried out using linear equations assuming that the fluid properties remain relatively constant. The components of the total pressure drop (pressure drop due to friction, potential and acceleration) can be expressed as,

$$\left[\frac{dP}{dL} \right]_{fri} = \frac{fG^2}{4r_w P} \quad (4.1)$$

$$\left[\frac{dP}{dL} \right]_{pot} = \rho g \sin \theta \quad (4.2)$$

$$\left[\frac{dP}{dL} \right]_{acc} = \frac{d(Gu)}{dL} \quad (4.3)$$

where,

- f = friction factor
- G = mass velocity

- r_w = well radius
- ρ = density of fluid
- g = gravity constant
- θ = deviation angle from horizontal
- u = average fluid velocity

Note that all parameters (symbols) and their units are given in the Nomenclature.

The friction factor f , is given by White (1979),

If $Re < 2400$:

$$f = \frac{64}{Re} \quad (4.4)$$

If $Re > 2400$:

$$\frac{1}{f} = -2.0 \log_{10} \left[\frac{\frac{\epsilon}{2r_w}}{3.7} + \frac{2.51}{Re f^{0.5}} \right] \quad (4.5)$$

where,

- Re = Reynolds number
- ϵ = pipe roughness

4.3 TWO-PHASE FLOW

4.3.1 Basic Definitions

This section introduces the important expressions and ratios used for two-phase flow. These formula are taken after Chisholm (1983) and presented in the same form as that expressed by Bjornsson (1987).

Mass Fraction

$$x = \frac{\dot{m}_v}{\dot{m}} = \frac{\dot{m}_v}{\dot{m}_v + \dot{m}_l} \quad (4.6)$$

where,

\dot{m} = mass flow rate
subscripts v and l stand for gas and liquid, respectively.

Mass Velocity

$$G = \frac{\dot{m}_v + \dot{m}_l}{A_v + A_l} \quad (4.7)$$

where,

A = cross-sectional area
 A_v = cross-sectional area occupied by the gas
 A_l = cross-sectional area occupied by the liquid

Velocity Ratio

$$K = \frac{u_v}{u_l} \quad (4.8)$$

where,

u = velocity

Continuity Equation

$$\dot{m}_v = u_v \rho_v A_v = u_v \rho_v S A \quad (4.9)$$

$$\dot{m}_l = u_l \rho_l A_l = u_l \rho_l S A \quad (4.10)$$

Gas Saturation

$$S = \frac{A_v}{A} = \frac{A_v}{A_v + A_l} \quad (4.11)$$

From Equations (4.6) to (4.11), S can also be expressed in terms of K and x.

$$S = \left[1 + K \frac{(1-x) \rho_v}{x \rho_l} \right]^{-1} \quad (4.12)$$

Gas, Liquid and Homogeneous Velocities

Combining Equations (4.6) to (4.11), the following relations can be derived,

$$u_v = G \left[\frac{x}{P_v} + \frac{K(1-x)}{P_1} \right] \quad (4.13)$$

$$u_1 = \frac{G}{K} \left[\frac{x}{P_v} + \frac{K(1-x)}{P_1} \right] \quad (4.14)$$

When the velocity ratio, K , is unity, the phase velocities are the same. This velocity is known as the homogeneous velocity, u_H .

$$u_H = G \left[\frac{x}{P_v} + \frac{(1-x)}{P_1} \right] \quad (4.15)$$

Volumetric Flow Rates

$$Q_v = A_v u_v = \frac{x G A}{P_v} \quad (4.16)$$

$$Q_1 = A_1 u_1 = \frac{x G A}{P_1} \quad (4.17)$$

Gas Volumetric Flowrate Ratio

$$\beta = \frac{Q_v}{Q_v + Q_1} = \left[1 + \frac{1-x}{x} \frac{P_v}{P_1} \right] \quad (4.18)$$

Density of Mixture

$$P_m = S P_v + (1-S) P_1 \quad (4.19)$$

An alternative expression for the mixture density can be obtained as a function of the mass fraction, x , and velocity ratio, K . By combining Equations (4.12) and (4.19), P_m can be expressed as,

$$P_m = \frac{x + K(1-x)}{\left[\frac{x}{P_v} + \frac{K(1-x)}{P_1} \right]} \quad (4.20)$$

Choked Flow

Choked flow occurs when the maximum possible flowrate through a pipe is achieved. This occurs when the total pressure gradient is required to overcome the changes in momentum flux. The choke velocity in two-phase flow is estimated to be (Kjaraan and Eliasson, 1983),

$$u_{CH} = \left[\frac{k_m}{P_m} \right] \quad (4.21)$$

and,

$$\frac{1}{k_m} = \frac{S}{k_v} + \frac{(1-S)}{k_l} \quad (4.22)$$

where,

$$k = \text{fluid incompressibility} = \frac{p}{\rho} \frac{d\rho}{dp}$$

subscripts m, v, and l stand for mean, gas and liquid respectively.

The flow is assumed choked when $u_{CH} > u_H$, the homogeneous fluid velocity.

4.3.2 Description and Determination of Flow Regimes

Generally for a flowing geothermal well, one encounters different flow regimes along its entire length. Any correlation developed specifically for any one of these conditions would be inadequate to describe the flow behavior in the entire well. Thus, an accurate description of the flow behavior in a pipe entails identifying the different flow regimes. In this work, the definitions used by Orkiszewski (1967) are used to describe the different two-phase flow regimes. These are: bubble, slug, transition (slug-annular) and annular-mist (see Figure 4.1).

Orkiszewski (1967) developed a correlation used to identify the different flow regimes. He based his correlations by analysing pressure data from 148 oil wells. The criteria are tabulated in Table 4.1.

TABLE 4.1

FLOW REGIMES AND CRITERIA (after Bjornsson, 1987)

FLOW REGIME	CRITERIA
Bubble	$\beta < L_B$
Slug	$\beta > L_B$ and $v_{gD} < L_B$
Transition	$L_B < v_{gD} < L_M$
Mist	$L_M < v_{gD}$

where,

$$v_{gD} = \frac{xG}{P_v} \left[\frac{P_1}{g\sigma} \right]^{0.25} \quad (\sigma = \text{surface tension})$$

$$v_t = G \left[\frac{x}{P_v} + \frac{(1-x)}{P_1} \right]$$

$$L_B = 1.071 - 0.676 \frac{v_t^2}{2r_w} \quad \text{and } L_B > 0.13$$

$$L_S = 50 + 36 v_{gD} \frac{Q_1}{Q_v}$$

$$L_M = 50 + 36 \left[v_{gD} \frac{Q_1}{Q_v} \right]^{0.75}$$

$$\beta = \frac{Q_v}{Q_v + Q_1}$$

4.3.3 Pressure Drop due to Friction

4.3.3.1 Vertical Pipes

The pressure drop for two-phase flow can be evaluated using the concept of "two-phase multiplier" (Martinelli and Nelson, 1948).

$$\left[\frac{dP}{dL} \right]_{2p} = \phi_{FLO}^2 \left[\frac{dP}{dL} \right]_{LO} \quad (4.23)$$

where,

ϕ_{FLO}^2 = two-phase multiplier

$\left[\frac{dP}{dL} \right]_{2p}$ = two-phase frictional pressure drop

$\left[\frac{dP}{dL} \right]_{LO}$ = single-phase liquid frictional pressure drop (Equation 4.1)

A generalized correlation of the two-phase multiplier has been presented by Chisholm (1983), independent of flow regime. It has the following form,

$$\phi_{FLO}^2 = 1 + (\Gamma^2 - 1) [B_s x^{(2-n)/n} (1-x)^{(2-n)/n} + x^{(2-n)}] \quad (4.24)$$

where,

Γ^2 = physical property parameter

B_s = semi-empirical coefficient

n = Blasius exponent; 0.25 for smooth pipes; 0 for fully rough flow (geothermal wells)

Γ^2 is defined as the ratio of the pressure drop if the fluid is single-phase gas to the pressure drop if the fluid is single-phase liquid. This can be expressed as,

$$\Gamma^2 = \frac{\left[\frac{dP}{dL} \right]_{GO}}{\left[\frac{dP}{dL} \right]_{LO}} = \left[\frac{\mu_v}{\mu_l} \right]^n \left[\frac{P_l}{P_v} \right] \quad (4.25)$$

where,

μ = viscosity

P = density

n = Blasius exponent

subscripts LO, GO, v and l stand for liquid only, gas only, gas and liquid respectively.

The coefficient B_s is evaluated using Table 4.2. To correct for the surface roughness of the pipe, Chisholm suggested the relationship,

$$\frac{B_r}{B_s} = \left[0.5 \left[1 + \left[\frac{\mu_v}{\mu_l} \right]^2 + 10^{(-300\epsilon/r_w)} \right] \right]^{(0.25-n)/n} \quad (4.26)$$

where,

ϵ = pipe roughness

r_w = pipe radius

Then for geothermal wells ($n=0$), Equation (4.24) above can be simplified to,

$$\phi_{FLO}^2 = 1 + (\Gamma^2 - 1) [B_R x(1 - x) + x^2] \quad (4.27)$$

TABLE 4.2

VALUES OF B_S FOR SMOOTH PIPES (from Chisholm, 1983)

Γ	G (kg/m ² s)	B_s
≤ 9.5	≤ 500	4.8
	$500 \leq G \leq 1900$	2400/G
	≥ 1900	$55/G^{1/2}$
$9.5 < \Gamma < 28$	≤ 600	$520/(\Gamma G^{1/2})$
	> 600	$21/\Gamma$
≥ 28		$15000/(\Gamma^2 G^{1/2})$

4.3.3.2 Inclined Pipes

For steam-water mixtures Haywood et. al. (1961) obtained a large amount of data for both horizontal and vertical pipes and found that no significant influence of pipe inclination was observed.

At present time, no available methods have been found to predict the effect of inclination angle in frictional pressure drop (Chisholm, 1983). Therefore, in this study, the correlation for vertical pipes was used for inclined pipes.

4.3.4 Velocities of Individual Phases

Two methods are presented here to evaluate the velocities of gas and liquid phases used in the evaluation of the momentum flux and energy equations. These methods are based on empirical correlations.

4.3.4.1 Armand Correlation

Armand (1946) correlated data for the saturation, S , during air/water flow in pipes. He proposed the relationship,

$$S = C_A \beta \quad (4.28)$$

where,

β = gas volumetric flowrate ratio, evaluated using Equation (4.18)

C_A = Armand Coefficient

Chisholm (1983) reviewed Armand's approach and correlated it with the results from the work done by Beggs (1972) to include effects of pipe inclination. He recommended several equations for calculating C_A for horizontal, vertical and inclined pipes. These equations are tabulated in Table 4.3.

4.3.4.2 Orkiszewski Correlation

The phase velocities can also be calculated using the correlations developed based on the flow regimes as defined by Orkiszewski (1967). The general equation for the calculation of gas phase velocity is,

$$u_v = u_H + \begin{cases} u_b \\ \text{or} \\ u_T \end{cases} \quad (4.29)$$

Bubble Flow

For this regime, the bubble velocity is evaluated from the correlation given by Govier and Aziz (1972).

$$u_b = 1.53 \left[\frac{g \sigma (P_v - P_1)}{P_1^2} \right]^{1/4} \quad (4.30)$$

Slug Flow

$$u_T = 0.35 \left[2r_w g \left[1 - \frac{P_v}{P_1} \right] \right]^{1/2} \quad (4.31)$$

TABLE 4.3

EQUATIONS FOR THE ARMAND COEFFICIENT (after Chisholm, 1983)

β	θ	EQUATIONS
<0.9	Horizontal (0°)	$\frac{1}{C_{Ah}} = 0.7 + \frac{0.3}{[1 - 0.7(1 - v_l/v_v)]^{1/2}}$
	Vertical (90°)	<p><u>For:</u></p> $u_H < \frac{u_{WD}}{(1/C_{Ah})-1} ; C_{Av} = C_{Ah}$ <hr/> <p><u>For:</u></p> $u_H > \frac{u_{WD}}{(1/C_{Ah})-1} ; w = 14 \left[\frac{v_v}{v_l} \right]^{0.2} \left[1 - \frac{v}{v_v} \right]^5$ <p><u>If,</u></p> $D > 19 \left[\frac{\sigma v_l}{g(1-v_l/v_v)} \right]^{1/2} ,$ $\frac{1}{C_{Av}} = 1 \pm \frac{1.53w}{u_H} \left[\frac{g(v_v - v_l)v_v \sigma}{v_v} \right]^{1/2}$ <p><u>If,</u></p> $D < 19 \left[\frac{\sigma v_l}{g(1-v_l/v_v)} \right]^{1/2} ,$ $\frac{1}{C_{Av}} = 1 \pm \frac{0.35w}{u_H} \left[\frac{g(v_v - v_l)v_v \sigma}{v_v} \right]^{1/2}$ <p><i>Negative sign for downflow</i></p>
		All
>0.9	All	$\frac{1}{C_A} = 1 + \frac{23}{u_H} \left[\frac{\mu_l \mu_v v_v}{D} \right]^{1/2} \left[1 - \frac{v_l}{v_v} \right]$

Mist Flow

In the mist flow, velocities of both phases are assumed to be equal (homogeneous) and thus,

$$u_v = u_l = u_H \tag{4.32}$$

Transition Flow

In the transition regime, a linear interpolation between bubble velocity in slug and mist flow regimes is used. This is expressed as follows,

$$u_b = \left[\frac{L_M - v_{GD}}{L_M - L_S} \right] u_T \quad (4.33)$$

where,

u_H = homogeneous velocity as defined by Equation (4.15)

u_b = bubble velocity

u_T = slug velocity

L_M , v_{GD} and L_S are empirical variables defined in Table 4.1.

Also by combining Equations (4.6), (4.7), (4.9) and (4.0), the expression for the liquid phase velocity can be derived. The value of u_l can be evaluated by solving simultaneously Equations (4.34) and (4.35) to yield:

$$u_l = \frac{G - u_v P_v S}{P_l (1-S)} \quad (4.34)$$

$$S = \frac{G x}{u_v P_v} \quad (4.35)$$

5.0 EQUATIONS OF STATE

5.1 WATER-CARBON DIOXIDE SYSTEM (CO₂-H₂O)

The mixture CO₂-H₂O is of great interest in the analysis of geothermal systems, since geothermal water often contains a significant amount of CO₂. Several workers have looked into the effects of CO₂ on the thermodynamics of geothermal fluids. Sutton (1976) and Sutton and McNabb (1977) have conducted studies on the effect of CO₂ on the boiling curves at Broadlands geothermal field New Zealand. Pritchett et al. (1981) also looked into the effects of CO₂ on the Baca Geothermal Reservoir, New Mexico. Gaulke (1986) demonstrated the use of CO₂ in the evaluation of geothermal reservoirs.

For pure water, the two-phase region is defined by the loci of points known as the saturation curve. This is shown in Figure 5.1. If the actual fluid pressure is below the saturated pressure for a given temperature, then the fluid exists as a single phase steam. If the fluid pressure is above the saturated pressure at the given temperature, then the fluid can only exist as liquid water. All two-phase conditions are confined to lie on the saturation curve.

When CO₂ is present, two effects have been found to occur on the region of the saturation curve (Pritchett et al., 1981). First, the boiling point pressure (pressure at which two-phase starts to form) for a fixed temperature increases. This means that if a system consisting of pure water in the compressed-liquid state undergoes pressure decrease, the fluid will turn two-phase as the saturation pressure is reached. If a certain amount of CO₂ is present, the pressure at which two-phase starts to form (P_{min}) will be greater than the saturation pressure for pure water. As more CO₂ is added, the pressure difference becomes higher. On the other hand, if a fluid consisting of water and CO₂ initially at the gaseous state is compressed, liquid water will start to form at a particular pressure (P_{max}) in the absence of CO₂, this will occur at the saturation pressure. In the presence of CO₂, the pressure at which liquid starts to form was found to be only slightly greater than for pure water. Consequently, with the presence of CO₂, the boiling pressure will exceed the condensation pressure (the pressure at which a gaseous mixture condenses). Both pressures will exceed the saturation pressure for pure water shown as dashed line in Figure 5.2. Figure 5.2 shows a pressure vs. temperature plot for system containing 1% total mass fracture CO₂. The width of the two-phase region, shown as a shaded area in Figure 5.2 will increase with increasing CO₂.

5.1.1 CRITERIA FOR DETERMINING THE STATE OF THE FLUID

Depending upon the value of total pressure, temperature and the total mass fraction of CO_2 , the fluid can exist as: (1) an all-liquid solution of CO_2 in water, (2) a mixture of liquid solution and gas, or (3) an all-gas solution of CO_2 in steam.

5.1.1.1 All-Liquid Solution of CO_2 and H_2O

If the total pressure is greater than the saturation pressure of pure water at the given temperature and the solubility of CO_2 in water is greater than the given total mass fraction of CO_2 , then the fluid is in the liquid state.

5.1.1.2 Two-Phase

If the total pressure is greater than the saturation pressure of pure water at the given temperature but the solubility of CO_2 in water is less than the given mass fraction of CO_2 , then a corresponding gas phase will exist. The fluid then exists in a two-phase condition.

5.1.1.3 All-Gas

If the total pressure is less than or equal to the saturation pressure of pure water at the given temperature and mass fraction of CO_2 , then the fluid can only exist as an all-gas state.

5.1.2 PARTITIONING OF CO_2 BETWEEN LIQUID AND GAS PHASE

Extensive experimental work on the solubility of CO_2 in water has been done by Takenouchi and Kennedy (1964). Ellis and Golding (1963) also investigated the solubility of CO_2 in water and in NaCl solutions of up to 2 molal.

5.1.2.1 Solubility of CO_2 in Water

A fit on the data by Takenouchi and Kennedy (1964) was shown by Pritchett et al. (1981) to obey the following relationship,

$$\alpha_{1\text{CO}_2} = \frac{P_{\text{CO}_2}}{A + BP_{\text{CO}_2}} \quad (5.1)$$

where,

- $\alpha_{1\text{CO}_2}$ = mass fraction of CO_2 in liquid
- P_{CO_2} = the partial pressure of CO_2 in the coexisting gas phase
- A and B are constants evaluated as functions of temperature.

The partial pressure of CO_2 is evaluated as follows,

$$P_{\text{CO}_2} = P - P_g(T) \quad (5.2)$$

where,

- $P_g(T)$ = saturation pressure for H_2O at a given temperature.

The functions A and B are calculated by polynomials of the form

$$A_0 + A_1T + A_2T^2 \quad (5.3)$$

where,

- T = temperature in $^{\circ}\text{C}$

The values of the coefficients are tabulated in Table 5.1.

TABLE 5.1

VALUES OF COEFFICIENTS FOR CALCULATION OF CO_2 SOLUBILITY

SUBSCRIPT	A	B
0	1.03549E+03	2.04465E+01
1	1.60369E+01	-1.07449E-01
2	-4.83594E-02	1.44701E-04

5.1.2.2 Mass Fraction CO_2 in Gas

For states of geothermal interest, the mass fraction of CO_2 in gas which is in equilibrium with the liquid fits the experimental data of Takenouchi and Kennedy (1964) according to the relation,

$$\alpha_{\text{vCO}_2} = \frac{P_{\text{CO}_2}}{P} \quad (5.5)$$

where,

- α_{vCO_2} = mass fraction CO_2 in gas phase
- P_{CO_2} = partial pressure of CO_2 as expressed by Equation (5.2)
- P = the total pressure

For cases of dry gas (all gas state), the above relation becomes,

$$\alpha_{CO_2} = \frac{P_{CO_2}}{P} \quad (5.6)$$

where,

- α_{CO_2} = total mass fraction of CO_2

Equations 5.5 and 5.6 above fit the experimental data better than Dalton's Law, which states that the mole fraction of the component gas is proportional to its partial pressure.

5.1.3 DENSITY

5.1.3.1 Carbon Dioxide (CO_2)

The density of CO_2 is calculated from the expression obtained from Pritchett et al. (1981).

$$P_{CO_2} = \frac{P_b}{z(P_b, T_K) R T_K} \times 10^9 \quad (5.7)$$

where,

- P_{CO_2} = density of CO_2 in kg/m^3
- R = the gas constant, $1.88919E6$ erg/g-°K
- T_K = temperature in °K
- P_b = pressure in bars
- $z(P_b, T_K)$ = gas compressibility factor evaluated using an analytical fit of the data by Vargaftik (1975).

For pressures less than 300 bars,

$$z(P_b, T_K) = A + B(P_b - 300) + C(P_b - 300)^2 + D(P_b - 300)^3 + E(P_b - 300)^4 \quad (5.8)$$

For pressures greater than 300 bars,

$$z(P_b, T_K) = A + B(P_b - 300) + F(P_b - 300)^2 \quad (5.9)$$

where,

P_b = the pressure in bars

T_K = the temperature in °K

The temperature dependent coefficients are evaluated from,

$$A = A_0 + A_1 T_K + A_2 T_K^2 + A_3 T_K^3 + A_4 T_K^4 \quad (5.10)$$

$$B = B_0 + B_1 T_K + B_2 T_K^2 + B_3 T_K^3 + B_4 T_K^4 \quad (5.11)$$

$$C = C_0 + C_1 T_K + C_2 T_K^2 + C_3 T_K^3 + C_4 T_K^4 \quad (5.12)$$

$$D = D_0 + D_1 T_K + D_2 T_K^2 + D_3 T_K^3 + D_4 T_K^4 \quad (5.13)$$

$$E = \frac{1 - A + 300B - 300^2 C + 300^3 D}{300^4} \quad (5.14)$$

$$F = F_0 + F_1 T_K + F_2 T_K^2 + F_3 T_K^3 + F_4 T_K^4 \quad (5.15)$$

The values of the coefficients given in Table 5.2 give a satisfactory fit to the experimental data between 77 to 350°C.

TABLE 5.2

VALUES OF COEFFICIENTS FOR CALCULATION OF CO₂ DENSITY

	A	B	C	D	F
0	8.09759	-3.62183E-02	-3.43992E-03	-2.10949E-05	6.82528E-05
1	-7.10670E-02	3.73836E-04	2.77555E-05	1.66021E-07	-6.70714E-07
2	2.38501E-04	-1.32285E-06	-8.30370E-08	-4.86891E-10	2.37181E-09
3	-3.36774E-07	1.97631E-09	1.09429E-10	6.31079E-13	-3.57746E-12
4	1.72976E-10	-1.06781E-12	-5.36712E-14	-3.05175E-16	1.95665E-15

5.1.3.2 Mixtures

5.1.3.2.1 Liquid

Since the amount of CO₂ dissolved in the liquid phase is small (low solubility of CO₂ in water), it is assumed that the density of the liquid is equal to the density of pure water at the same temperature. So,

$$P_1 \approx P_{H_2O} \quad (5.16)$$

where,

$$\begin{aligned} P_1 &= \text{the density of mixture} \\ P_{H_2O} &= \text{the density of pure water} \end{aligned}$$

5.1.3.2.2 Gas

For the gas mixture, the same expression used by Sutton (1976) and Pritchett et al. (1981) is used.

$$P_g = P_s + P_{CO_2} \quad (5.17)$$

where,

$$\begin{aligned} P_s &= \text{the density of steam} \\ P_{CO_2} &= \text{the density of } CO_2 \end{aligned}$$

Both values of density are evaluated at the given temperature and corresponding partial pressures.

5.1.4 ENTHALPY

5.1.4.1 Carbon Dioxide (CO₂)

The enthalpy of CO₂ is evaluated using the formula given by Sweigert et al. (1946).

$$\begin{aligned} H_{CO_2} = & 1688 + 1.542T_K - 794.8 \text{LOG}_{10}(T_K) - \frac{4.135E+04}{T_K} \\ & - \frac{3.571E-04 P_{CO_2}}{(T_K/100)^{10/3}} (1 + 7.576E-08P_{CO_2}) \end{aligned} \quad (5.18)$$

where,

$$\begin{aligned} H_{CO_2} &= \text{the enthalpy of } CO_2 \text{ in kJ/kg} \\ P_{CO_2} &= \text{the partial pressure of } CO_2 \text{ in Pa} \\ T_K &= \text{the temperature in } ^\circ K \end{aligned}$$

5.1.4.2 Heat of Solution

The heat of solution of a gas is the change in enthalpy brought about by the dissolution of the gas in water. The equation of the heat of solution is calculated using a polynomial fit to the experimental data obtained by Ellis and Golding (1963) and is valid for temperatures in the range 100-300°C.

$$H_{\text{soln}} = -71.33 - 6.0198T + 0.07438T^2 - 2.9244E-04T^3 + 4.4522E-07T^4 \quad (5.19)$$

where,

$$\begin{aligned} H_{\text{soln}} &= \text{the heat of solution in kJ/kg} \\ T &= \text{temperature in } ^\circ\text{C} \end{aligned}$$

5.1.4.3 Enthalpy of the Mixture

The enthalpy of the mixture is evaluated using,

$$H_m = xH_v + (1 - x)H_l \quad (5.20)$$

where,

$$\begin{aligned} x &= \text{mass fraction of gas phase} \\ H_v &= \text{enthalpy of the gas phase in kJ/kg} \\ H_l &= \text{enthalpy of the liquid phase in kJ/kg} \end{aligned}$$

The liquid and gas phase enthalpies are evaluated as average enthalpies of the different components weighted by their individual mass fractions.

$$H_l = (1 - \alpha_{\text{lCO}_2})H_w + \alpha_{\text{vCO}_2}(H_{\text{CO}_2} + H_{\text{soln}}) \quad (5.21)$$

and,

$$H_v = (1 - \alpha_{\text{vCO}_2})H_s + \alpha_{\text{vCO}_2} H_{\text{CO}_2} \quad (5.22)$$

where,

$$\begin{aligned} \alpha &= \text{mass fraction CO}_2 \\ H &= \text{enthalpy, kJ/kg} \end{aligned}$$

The subscripts l, v, w, s, lCO₂, vCO₂ and soln stand for liquid phase, gas phase, water, steam, CO₂ in liquid phase, CO₂ in gas phase and solution respectively.

The total mass fraction of the gas phase, x , is calculated using a mass balance on CO_2 .

$$x = \frac{\alpha_{\text{CO}_2} - \alpha_{1\text{CO}_2}}{\alpha_{\text{vCO}_2} - \alpha_{1\text{CO}_2}} \quad (5.23)$$

5.1.5 VISCOSITY

5.1.5.1 Carbon Dioxide (CO_2)

Fits to the viscosity of CO_2 as a function of pressure and temperature are based on the data tabulated by Vargaftik (1975). For the viscosity, μ_{CO_2} , in poise,

$$\mu_{\text{CO}_2} = (A + BT + CT^2 + DT^3 + ET^4) \times 10^{-8} \quad (5.24)$$

where,

$$T = \text{temperature in } ^\circ\text{C}$$

The pressure dependent coefficients are found from the linear interpolation between the tabulated values in Table 5.3.

5.1.5.2 Mixture

The viscosity of the liquid phase is assumed to be approximately equal to the viscosity of pure water since the amount of dissolved CO_2 is small. For the gas phase, a weighted average is used.

$$\mu_l \approx \mu_{\text{H}_2\text{O}} \quad (5.25)$$

$$\mu_v = \alpha_{\text{vCO}_2} \mu_{\text{CO}_2} + (1 - \alpha_{\text{vCO}_2}) \mu_s \quad (5.26)$$

5.1.6 SURFACE TENSION

The effect of CO_2 on the surface tension of water has been studied by Heuer (1957) as part of his Ph.D. dissertation. He measured the interfacial tension of $\text{H}_2\text{O}-\text{CO}_2$ at different temperatures and partial pressures of CO_2 (P_{CO_2}). The results are shown in Figure 5.3.

TABLE 5.3

VALUES OF COEFFICIENTS FOR CALCULATION OF CO₂ VISCOSITY

P (bars)	A	B	C	D	E
0	1357.8	4.9227	-2.96610E-03	2.85290E-06	-2.18290E-09
100	3918.9	-35.984	2.58250E-01	-7.11780E-04	6.95780E-07
150	9660.7	-135.479	9.00870E-01	-2.47270E-03	2.41560E-06
200	13156.6	-179.352	1.12474	-2.98864E-03	2.85911E-06
300	14796.8	-160.731	8.50257E-01	-1.99076E-03	1.73423E-06
400	15758.3	-144.887	6.73731E-01	-1.41990E-03	1.13548E-06
500	16171.6	-125.341	5.00750E-01	-9.04721E-04	6.19087E-07
600	16839.4	-115.700	4.08927E-01	-6.35032E-04	3.53981E-07

Although the results showed that interfacial tension decreases with increasing P_{CO₂}, partial pressures greater than 10 bars at the wellhead rarely occur in geothermal well discharge fluids. At P_{CO₂} lower than 10 bars, the decrease in surface tension is less than 15%. Therefore in this study, the interfacial tension of H₂O-CO₂ is assumed to be approximately the same as that for pure water.

$$\sigma_m \approx \sigma_{H_2O} \quad (5.27)$$

where,

$$\begin{aligned} \sigma_m &= \text{surface tension of mixture} \\ \sigma_{H_2O} &= \text{surface tension of water} \end{aligned}$$

5.2 WATER-SODIUM CHLORIDE SYSTEM (H₂O-NACL)

The total dissolved solids in geothermal brines varies from that of ordinary well water up to concentrated solutions as high as 40% by weight. Sodium chloride (NaCl) is typically 70 to 80% of the total dissolved solids. The other most abundant components are potassium chloride (KCl), calcium chloride (CaCl₂) and silica (SiO₂). The silica concentration in geothermal brines is usually between 200 and 600 ppm (Wahl, 1977). Since NaCl is the major component of the total dissolved solids, the geothermal brine can be treated as a solution of NaCl in water to evaluate its fluid properties. The principal effects of dissolved solids are boiling point elevation, increased viscosity, increased density, increased surface tension and decreased specific heat.

5.2.1 CRITERIA FOR DETERMINING THE STATE OF THE FLUID

At a constant pressure, the boiling point temperature of the solution increases as the salt concentration increases. This is shown in Figure 5.4. Depending upon these saturation curves, the fluid can exist as single-phase liquid, single-phase gas or two-phase fluid.

5.2.1.1 Single-Phase Liquid

If the total pressure is greater than the saturation pressure at a given temperature and salt concentration in brine, the fluid is in the liquid state.

5.2.1.2 Two-Phase

If the total pressure is equal to the saturation pressure at a given temperature and salt concentration in brine, then the fluid is in two-phase condition.

5.2.1.3 Single-Phase Gas

The other remaining case is for single-phase steam. This occurs if the total pressure is less than the saturation pressure at the given temperature and salt concentration.

5.2.2 SOLUBILITY OF NaCl IN WATER

The solubility of NaCl in water as a function of temperature is obtained from a polynomial fit of the data presented by Haas, 1976. The equation is valid for temperature between 80 to 325°C.

$$S = 26.218166 + 7.199079E-03 T + 1.060020E-04 T^2 \quad (5.28)$$

where,

S = solubility in wt%
T = temperature in °C.

5.2.3 SATURATION TEMPERATURE

The boiling point of brine at a given pressure and salt concentration can be evaluated from the expression given by Haas, 1976. This expression is a fit of the experimental data between -11 to 300 °C.

$$\ln T_o = \frac{\ln T_{sat}}{a + bT_{sat}} \quad (5.29)$$

where,

T_o = saturation temperature of pure water pressure, °K.

T_{sat} = saturation temperature of brine solution, °K.

a,b are the coefficients from the polynomial fit.

The coefficients, a and b, are functions of the salt concentration and can be evaluated using the expression below:

$$a = 1 + a1(\alpha_{mnacl}) + a2(\alpha_{mnacl})^2 + a3(\alpha_{mnacl})^3 \quad (5.30)$$

$$b = b1(\alpha_{mnacl}) + b2(\alpha_{mnacl})^2 + b3(\alpha_{mnacl})^3 + b4(\alpha_{mnacl})^4 + b5(\alpha_{mnacl})^5 \quad (5.31)$$

where,

α_{mnacl} = salt concentration

a1 = 5.93582E-06

a2 = -5.19386E-05

a3 = 1.23156E-05

b1 = 1.15420E-06

b2 = 1.41254E-07

b3 = -1.92476E-08

b4 = -1.70717E-09

b5 = 1.05390E-10

5.2.4 SATURATION PRESSURE

The vapor pressure of the brine P_{sat} at a given brine temperature T can be calculated from (Haas, 1976)

$$\ln P_{\text{sat}} = e_0 + \frac{e_1}{z} + \frac{e_2}{z} (10^{e_3 w^2} - 1.0) + e_4 10^{(e_5 y^{1.25})} \quad (5.32)$$

where,

$$\begin{aligned} P_{\text{sat}} &= \text{saturation pressure, bars} \\ e_0 &= 12.50849 \\ e_1 &= -4.616913\text{E}+03 \\ e_2 &= 3.193455\text{E}-04 \\ e_3 &= 1.1965\text{E}-11 \\ e_4 &= -1.013137\text{E}-02 \\ e_5 &= -5.7148\text{E}-03 \\ e_6 &= 2.9370\text{E}+05 \\ y &= 647.27 - T_o \\ z &= T_o + 0.01 \\ w &= z^2 - e_6 \end{aligned}$$

T_o is the equivalent temperature of pure water and can be evaluated from Equation 5.29 by setting T_{sat} equal to the brine temperature, T .

5.2.5 DENSITY

The density of vapor-saturated brine solution is evaluated using the formula given by Haas, 1976. For compressed liquid, the expression presented by Phillips et al., 1981 is used. For single phase vapor condition, the density is calculated equal to the density of pure steam at the given temperature and pressure.

Liquid Brine

(a) Vapor-Saturated

$$P_1 = \frac{1000 + \alpha_{\text{mnacl}} \text{MW}_{\text{nacl}}}{1000 \bar{v}_{P_o} + \alpha_{\text{mnacl}} v_{\text{nacl}}} \quad (5.33)$$

where,

$$\begin{aligned} \text{MW}_{\text{nacl}} &= \text{molecular weight of NaCl} \\ \alpha_{\text{mnacl}} &= \text{NaCl concentration, molal} \\ \bar{v}_o &= \text{specific volume of pure water, cm}^3/\text{g} \\ v_{\text{nacl}} &= \text{apparent molal volume of NaCl in water, cm}^3/\text{mol} \end{aligned}$$

The apparent molal volume, v_{nacl} , can be calculated using the expression:

$$v_{\text{nacl}} = v_{\text{nacl}}^* + kk (\alpha_{\text{nacl}})^{1/2} \quad (5.34)$$

where,

$$v_{\text{nacl}}^* = c_0 + c_1 \bar{v}_o + c_2 \bar{v}_o^2 \quad (5.35)$$

$$kk = (c_3 + c_4 \bar{v}_o) \left[\frac{\bar{v}_o}{v_c - \bar{v}_o} \right] \quad (5.36)$$

and,

$$\bar{v}_o = \frac{v_c + c_5 T_d^{1/3} + c_6 T_d + c_7 T_d^4}{1 + c_8 T_d^{1/3} + c_9 T_d} \quad (5.37)$$

where,

v_c	=	specific volume of water at critical point (3.1975 cm ³ /g)
c_0	=	-167.219
c_1	=	448.55
c_2	=	-261.07
c_3	=	-13.644
c_4	=	13.97
c_5	=	-0.315154
c_6	=	-1.203374E-03
c_7	=	7.48908E-13
c_8	=	0.1342489
c_9	=	-3.946263E-03
T_d	=	temperature difference between water at critical point and brine temperature both expressed in °K
	=	(647.27 - T)

(b) Compressed Liquid

$$P_1 = -3.033405 + 10.128163 XX - 8.750567 XX^2 + 2.663107 XX^3 \quad (5.38)$$

and,

$$XX = -9.9559e^{(-4.539E-03\alpha_{\text{mnacl}})} + 7.0845e^{(-1.638E-04T)} + 3.9093 e^{(2.551E-05P_b)} \quad (5.39)$$

where,

$$\begin{aligned} P_1 &= \text{brine density, g/cm}^3 \\ T &= \text{brine temperature, } ^\circ\text{C} \\ P_b &= \text{pressure, bars} \end{aligned}$$

Vapor

The density of the vapor is calculated equal to the density of pure steam at the given temperature and pressure.

5.2.6 ENTHALPY

The liquid and vapor enthalpies are evaluated using the polynomial fit of the data tabulated by Haas, 1976. The equations given below with the enthalpy expressed in kJ/kg are valid in the range 80-325 °C up to a salt concentration of 30%. at higher salt concentrations, the equations are valid between 170-325 °C.

$$H_1 = AA_0 + AA_1T + AA_2T^2 + AA_3T^3 + AA_4T^4 + AA_5T^5 \quad (5.40)$$

$$H_v = BB_0 + BB_1T + BB_2T^2 + BB_3T^3 + BB_4T^4 + BB_5T^5 \quad (5.41)$$

where,

$$\begin{aligned} H_1 &= \text{brine enthalpy, kJ/kg} \\ H_v &= \text{vapor enthalpy, kJ/kg} \\ T &= \text{temperature, } ^\circ\text{C} \end{aligned}$$

The values of the coefficients at different salt concentrations (in mass fractions) are tabulated in Tables 5.4 and 5.5.

5.2.7 VISCOSITY

Brine Solution

The viscosity of the brine solution decreases with increasing temperature and increases with increased salt concentration. The viscosity of the brine solution is expressed by Phillips et al., 1981 as function relative to the viscosity of pure water. The equation, given below, is valid for temperatures between 10-350°C, pressures between 0.1-50 MPa and salt concentrations of 0-5 molal.

$$\frac{\mu_1}{\mu_{H_2O}} = 1 + 0.0816\alpha_{mnac1} + 0.0122\alpha_{mnac1}^2 + 1.28E-04\alpha_{mnac1}^3 + 6.29E-04T[1 - e^{(-0.7\alpha_{mnac1})}] \quad (5.42)$$

where,

- μ_1 = viscosity of brine, kg/m-s
- μ_{H_2O} = viscosity of pure water, kg/m-s
- T = temperature, °C
- α_{mnac1} = salt concentration, molal

Vapor

Viscosity of the vapor is taken to be equal to the viscosity of pure steam at the given temperature and pressure.

5.2.8 SURFACE TENSION

In an ionic solution, the increased electrostatic forces resulting from the ions will increase the forces of attraction on the surface layers of water molecules, thus increasing the surface tension of an ionic salt solution. The surface tension of the brine solution can be calculated using the formula presented below (Wahl, 1977):

$$\sigma = 0.00757(374.15 - T)^{0.776}(1 + 0.0039w_t + 4.35E-05w_t^2) \quad (5.43)$$

where,

- σ = surface tension, dyne/cm
- T = temperature, °C
- w_t = salt concentration, wt%

TABLE 5.4

VALUES OF AA COEFFICIENTS FOR CALCULATION OF BRINE ENTHALPY

NaCl (wt%)	AA ₀	AA ₁	AA ₂	AA ₃	AA ₄	AA ₅
0	24.3283	3.4590	7.7423E-3	-3.8710E-5	9.8560E-8	-6.6832E-11
2.84	3.8978	3.9660	1.5473E-3	-1.0486E-5	4.1365E-8	-4.0272E-11
5.00	-8.6554	4.2491	-1.8147E-3	3.6084E-6	1.6307E-8	-3.5661E-11
5.52	-2.9781	4.0648	1.3506E-4	-7.0009E-6	4.3088E-8	-6.2676E-11
8.06	6.4063	3.7396	2.8065E-3	-2.1195E-5	8.1121E-8	-1.1220E-10
10.00	-7.7332	4.0169	3.4854E-4	-1.5552E-5	8.5077E-8	-1.3786E-10
10.47	-7.0980	3.9819	7.2529E-4	-1.8598E-5	9.6257E-8	-1.5404E-10
12.75	-25.1930	4.4954	-6.0681E-3	1.8814E-5	-1.4513E-9	-6.1698E-11
14.92	-21.7218	4.3128	-4.5295E-3	9.7266E-6	2.4261E-8	-9.3763E-11
15.00	-24.3103	4.4095	-5.9033E-3	1.8744E-5	-3.5968E-9	-6.1554E-11
16.98	-13.3055	4.0101	-1.9609E-3	-2.7629E-6	5.2988E-8	-1.2188E-10
18.95	-20.1016	4.1503	-4.4275E-3	1.2487E-5	8.3083E-9	-7.4095E-11
20.00	-17.9762	3.9897	-2.3208E-3	-2.1036E-6	5.4212E-8	-1.2821E-10
20.82	-26.3103	4.2246	-5.4460E-3	1.6101E-5	4.1867E-9	-7.6350E-11
22.61	-17.0245	3.8503	-2.2900E-3	2.6043E-6	2.9538E-8	-9.2192E-11
24.32	-15.2398	3.6756	-9.8531E-4	-2.5180E-6	3.7287E-8	-9.3442E-11
25.00	-17.7890	3.6737	-9.6132E-4	-3.5030E-6	4.1930E-8	-9.9377E-11
25.96	-23.8474	3.7443	-1.9361E-3	1.8178E-6	2.7380E-8	-8.2566E-11
27.53	-13.0809	3.3248	1.2043E-3	-8.0111E-6	3.5269E-8	-7.2261E-11
29.03	68.5197	1.5947	1.3268E-2	-4.5410E-5	7.9375E-8	-7.3478E-11
30.00	201.1564	0.0333	1.3960E-2	4.9802E-6	-1.3669E-7	1.9756E-10
30.47	168.2466	0.2923	1.4842E-2	-1.0985E-5	-8.0984E-8	1.3746E-10
31.86	-649.4048	9.8268	-1.2149E-2	8.1793E-5	3.7204E-7	-4.2856E-10
33.19	-1076.2268	13.5234	-2.5886E-2	-2.2676E-5	1.4012E-7	-8.6452E-11
34.47	-2232.6724	20.3039	-2.2856E-2	-6.2959E-5	8.0256E-9	3.2632E-10
35.00	397.1754	2.2554	-1.9632E-2	1.0808E-4	-1.9957E-7	1.4452E-10
35.70	1970.7611	-10.1111	1.5597E-2	1.1827E-6	1.8907E-7	-3.8994E-10
36.89	-313.7351	7.9131	-8.4302E-3	-6.8802E-5	1.8988E-7	-1.2079E-11

TABLE 5.5

VALUES OF BB COEFFICIENTS FOR CALCULATION OF VAPOR ENTHALPY

NaCl (wt%)	BB ₀	BB ₁	BB ₂	BB ₃	BB ₄	BB ₅
0	2446.2217	3.4338	-1.7216E-2	7.6865E-5	-1.9086E-7	1.2083E-10
2.84	2480.0190	2.3510	-4.2241E-3	4.0796E-6	1.6907E-9	-6.9543E-11
5.00	2434.6228	3.6958	-1.9244E-2	8.3982E-5	-2.0143E-7	1.3176E-10
5.52	2454.7854	3.1093	-1.2826E-2	5.0779E-5	-1.1951E-7	5.4818E-11
8.06	2484.1694	2.2481	-3.3417E-3	1.8000E-6	7.740E-10	-5.4977E-11
10.00	2431.6914	3.8447	-2.1670E-2	1.0180E-4	-2.5914E-7	2.0658E-10
10.47	2415.4656	4.3380	-2.7300E-2	1.3222E-4	-3.3733E-7	2.8420E-10
12.75	2461.3501	2.9921	-1.2452E-2	5.5057E-5	-1.4612E-7	1.0537E-10
14.92	2447.1401	3.4389	-1.7747E-2	8.5107E-5	-2.2691E-7	1.9117E-10
15.00	2458.7734	3.0840	-1.3672E-2	6.3005E-5	-1.6990E-7	1.3500E-10
16.98	2492.6707	1.9952	-5.5975E-4	-1.0853E-5	2.7151E-8	-6.2805E-11
18.95	2492.5652	2.0271	-1.2558E-3	-4.9829E-6	7.1859E-9	-3.6303E-11
20.00	2472.6506	2.6476	-8.5314E-3	3.5514E-5	-9.9648E-8	7.2592E-11
20.82	2505.2444	1.6385	3.2375E-3	-2.9188E-5	6.9588E-8	-9.5816E-11

TABLE 5.5 (cont.)

VALUES OF BB COEFFICIENTS FOR CALCULATION OF VAPOR ENTHALPY

NaCl (wt%)	BB ₀	BB ₁	BB ₂	BB ₃	BB ₄	BB ₅
22.61	2438.7627	3.6664	-2.0065E-2	9.7918E-5	-2.6003E-7	2.3340E-10
24.32	2428.1958	3.9949	-2.3862E-2	1.1884E-4	-3.1406E-7	2.8816E-10
25.00	2492.0708	2.0675	-1.9891E-3	1.6513E-6	-1.5052E-8	-3.6188E-12
25.96	2451.8728	3.2611	-1.5332E-2	7.2512E-5	-1.9423E-7	1.7102E-10
27.53	2453.2974	3.2404	-1.5424E-2	7.5312E-5	-2.0672E-7	1.8930E-10
29.03	2471.5308	1.6846	9.5170E-3	-8.4284E-5	2.4727E-7	-2.8731E-10
30.00	1797.5771	11.4452	-3.2958E-2	-7.3318E-5	5.6141E-7	-8.0888E-10
30.47	2962.7830	-4.1519	1.9015E-2	4.1715E-5	-3.4740E-7	4.6296E-10
31.86	5955.7783	-39.2518	1.1080E-1	3.7794E-4	-2.2914E-6	2.9113E-9
33.19	1683.0183	10.9433	-2.8603E-2	-1.8258E-5	1.9546E-7	-2.4958E-10
34.47	4599.6313	-16.6867	4.7566E-2	-4.3308E-5	1.1615E-7	-3.1449E-10
35.00	2567.8904	0.8219	5.1158E-3	-1.2072E-5	-1.3523E-8	1.7705E-11
35.70	6230.8574	-24.1874	3.7339E-2	-3.8967E-5	5.2955E-7	-1.1057E-9
36.89	-2193.3730	35.7752	-1.8214E-2	-3.6811E-4	9.0074E-7	-5.6251E-10

6.0 DESCRIPTION OF THE SIMULATOR

6.1 OVERVIEW OF PROGRAM STRUCTURE AND EXECUTION

When program execution commences, the first menu prompts for the variable MODE. There are eight options available in this menu. After selecting the option in the first menu, the program goes to the second menu and prompts for a value of the variable ANS. In the second menu, the user chooses one of the two input options. These two input options will be described in detail below. After choosing the input option, the program then goes back into the first menu. The input data can either be read from a file or the user can directly input it from the terminal. A simplified flowchart is shown in Figure 6.1. Tabulated in Table 6.1 are a short description of the subroutines.

TABLE 6.1
DESCRIPTION OF THE SUBROUTINES

FUNCTION	SUBROUTINES		
	HOLA	GWELL	GWNACL
main program	HOLA	GWELL	GWNACL
menu	VALM1, VALM2	VALM1, VALM2	VALM1, VALM2
data input	CHANGE, INFILE, INKEY, OUTFILE	CHANGE, INFILE, INKEY, OUTFILE	CHANGE, INFILE, INKEY, OUTFILE
output	OUTPUT1, OUTPUT2	OUTPUT1, OUTPUT2	OUTPUT1, OUTPUT2
mass and energy balances at the feedzone mass and energy balances in between feed- zones	FEED1, FEED2 ENERGY, MOMENTUM RESEN, RESEN2, RESMOM, RESMOM2	FEED1, FEED2 ENERGY, MOMENTUM RESEN, RESEN2, RESMOM, RESMOM2	FEED1, FEED2 ENERGY, MOMENTUM RESEN, RESEN2, RESMOM, RESMOM2
equation of state	COWAT, GENERAL, HP, SAT, SOLVE, SATURATE, SUPST, TENS, TOP, TSAT, VISS, VISW	CO2, COWAT, ENTHCO2, GENERAL HSOLN, MU, SAT, SATURATE, SOLUB, SOLVEPX, SOLVET, SUPST, TENS, TFIND, TOP, TSAT, VISCO2, VISS, VISW, VOLCO2	COWAT, DENSE, HBRINE, NAACL, PSALT, SAT, SATURATE, SOLUB, SOLVE, SUPST, SURF, TOP, TSALT, TSATN, VISC, VISS, VISW
initialization and determina- tion of grid nodes	FEEDNODE, MKGRID, NEWNODE, NEWNODE2	FEEDNODE, MKGRID, NEWNODE, NEWNODE2	FEEDNODE, MKGRID, NEWNODE, NEWNODE2

TABLE 6.1 (cont.)

DESCRIPTION OF THE SUBROUTINES

FUNCTION	SUBROUTINES		
	HOLA	GWELL	GWNACL
determination of flow regimes and flow characteristics	ARMAND, CHOKED, FRIC1, MOODY, REGIME	ARMAND, CHOKED, FRIC1, MOODY, REGIME	ARMAND, CHOKED, FRIC1, MOODY, REGIME
iteration routines	IT1, IT2, IT3, IT4, ITERATE1, ITERATE2, ITERATE3, ITERATE4, ITHAD, VINNA1, VINNA2	IT1, IT2, IT3, IT4, ITERATE1, ITERATE2, ITERATE3, ITERATE4, ITHAD, VINNA1, VINNA2	IT1, IT2, IT3, IT4, ITERATE1, ITERATE2, ITERATE3, ITERATE4, ITHAD, VINNA1, VINNA2
sorting routine for plotting	PLOTTA	PLOTTA	PLOTTA

(1) Option 1 (ANS=1)

This option needs the measured or known discharge condition at the wellhead (e.g. pressure, mass fraction CO₂, temperature and enthalpy). In addition, the flow rates and enthalpies of the feedzones are specified. Take note that for this option the last feedzone (at bottomhole) may not be specified since the program automatically calculates the condition of the last feedzone. The simulator then solves for the flowing temperature and pressure profile from the wellhead to bottomhole. The results can then be matched with the measured flowing temperature and pressure surveys to determine the relative contribution and fluid composition from the different feedzones.

(2) Option 2 (ANS=2)

In this option, the user specifies the required flowing wellhead pressure and bottomhole pressure, and the productivity indices (defined in Chapter 3), thermodynamic properties and composition of the fluid at each feedzone. The simulator then calculates for the flowing temperature and pressure from bottomhole to the wellhead and calculates the expected wellhead output (e.g. wellhead enthalpy, flowrate, pressure, temperature and fluid composition). For this option, unlike the input for option 1, all the feedzones have to be specified. This program can be used to

predict outputs of newly drilled wells using the parameters obtained from neighboring wells.

These three simulators have two major iteration subroutines that solve for the temperature and pressure in the well. Option 1 uses the subroutine VINNA1 and option 2 uses the subroutine ITHEAD.

(1) VINNA1

This subroutine calculates for the pressure, temperature and saturation profiles of a flowing well given the wellhead conditions and flowrate and enthalpy of each feedzone. The calculations proceed from the wellhead down to the bottom of the well.

(2) ITHEAD

This subroutine calculates for the flowrate and temperature at the wellhead given the required wellhead pressure. The productivity index, reservoir pressure and enthalpy (or temperature) at each feedzone have to be specified. The program will then compute for the flow contributions from each feedzone using Equation 3.13.

After the input data are read by the program, the calculations proceed using the equations as discussed in Chapter 3 and using either Orkizewski or Armand correlation. During the iteration procedure, negative temperatures or pressures are sometimes calculated if the flow is changing phase. This makes the program return to the previous node and add a new node to the grid, halfway between the previous node and the node where the unsuccessful iteration occurred.

The program execution may also be prematurely halted before the calculation reaches the bottom (or top) of the well. This happens for several reasons:

- (1) The program computes an impossible thermodynamic condition (e.g. negative temperature, pressure or mass fraction CO₂ or NaCl).
- (2) Fluid is above critical condition.
- (3) Error in iteration.
- (4) Unsuccessful iteration.
- (5) The simulator calculates velocities in the well more than twice the choke velocity.
- (6) The specified number of grid nodes is more than 400.

In all these cases, error messages will be printed on the screen and on the file called HOLA.LOG, GWELL.LOG or GWNACL.LOG depending on which simulator was used. If Option 2 is used additional messages are printed both on the screen and in the file called *.ITER (* indicates the name of the simulator used). This file contains data regarding the iteration process.

After a successful run, the program goes back to the first menu. The user can then save the results into a file. Take note that the subroutine PLOTTA (used for sorting the output for plotting) prompts for a file name, thus the user should first save the results into a file (Option 6) before sorting can be done (Option 7).

The subroutine PLOTTA creates five files. These are :

- 1 pvsz.dat - this file has two columns. The first column contains the calculated pressure in MPa-gauge and the second column contains the corresponding depth in the well in meters.
- 2 tvsz.dat - this file contains temperature in °C (first column) and the corresponding depth in meters (second column).
- 3 geom.dat - contains the casing design. The first column is the well radius in centimeters and the second column is corresponding depth in meters.
- 4 fzon.dat - contains the location of the feedzones in the well. The first column is the location of the x-axis where the point is to be plotted (set = 0). The second column is the depth in the well, in meters, where the feedzone is located.
- 5 flpt.dat - contains the location where phase change occurs in the well. The first column is the location of the x-axis where the point is to be plotted (set = 0). The second column is the depth at which a phase change occurs.

Take note that the subroutine PLOTTA is only a sorting program and can be changed or modified to tailor the output of the subroutine to a specific plotting software that the user might be using.

6.2 INPUT DATA

The input data can either be read from a file or can directly be inputted through the keyboard. In case changes in the data are needed, the user can either use the system editor to edit the file, or he can read the file and input the necessary corrections directly from the keyboard. The program also provides an option to save the edited input deck when inputting or changes were done interactively.

The structure of the input files for Options 1 and 2 are described below. The variables can be specified in either F or E format as long as the variables in a line are separated by at least a space. Samples of the input deck, output and message files (*.LOG and *.ITER) are attached in Appendix A. Positive flows at the wellhead or feedzones indicate production and negative flows indicate injection. In the well, a positive velocity or flowrate means upward flow and negative means downward flow.

For Option 1, the wellhead condition can be specified by pressure, total mass fraction CO₂ or NaCl and either temperature or enthalpy. For both Options 1 and 2, the feedzone fluid property can be specified by either fluid enthalpy or temperature. The format of the input deck, description of the variables and their corresponding units are tabulated below.

6.3 OUTPUT

Samples of the output files are given in the Appendices. The output of the codes contains the fluid condition and composition at the wellhead. Aside from this, the location of the feedzones, the flow rate, enthalpy and fluid composition are tabulated. For Option 2, additional information at the feedzone are tabulated. These are the reservoir pressure, fluid saturation and the productivity indices. The output also tabulates the calculated thermodynamic properties, flow condition and fluid composition at each feednode. These are:

Depth	-	depth in the well
Press	-	pressure in Pa
Temp	-	temperature in °C
Dryness	-	steam mass fraction
Hw	-	liquid enthalpy

Hs	-	steam enthalpy
Vw	-	liquid velocity
Vs	-	steam velocity
Dw	-	liquid density
Ds	-	steam density
H_t	-	total enthalpy of the fluid
Rad	-	well radius
Reg	-	flow regime
		Sl - slug, Bu - bubble, Tr - transition,
		Mi - mist, 1p - single phase
XCO2	-	mass fraction CO ₂ in total discharge
XNACL	-	mass fraction NaCl in total discharge

6.4 ADDITIONAL NOTES ON RUNNING THE PROGRAM

Please note that the program always interprets the last feedzone to occur at the bottom of the well. In cases where the last feedzone does not occur at the bottom of the well, specify the well geometry with an apparent well depth equal to the depth of the last feedzone.

In setting up the well grid, make sure that the length of pipe section is a multiple of the grid node size (variable DELZ). Also specify the depth of the feedzone to be located exactly at the depth of a grid node.

In cases where the user doesn't want to include wellbore conductive heat losses, set THCON = 0. During program execution, if the message "Thermal resistance not defined" appears, this means that the criterion specified to get the approximate solution for wellbore heat losses is not satisfied (see Equations 2.5 and 2.6). In this case the program proceeds calculation without considering conductive heat losses.

If temperature is specified for the condition of the fluid at the wellhead or at the feedzone, GWNACL and HOLA will compare the given temperature with the saturation temperature. If the given temperature is equal to the saturation temperature, these two codes will interpret the fluid as saturated single-phase liquid. Also, when fluid is injected into the feedzone, the program will set the thermodynamic condition of the fluid entering the feedzone equal to the thermodynamic condition of the flowing fluid inside the wellbore.

At present the code can only handle a maximum of 400 grid nodes. If the user wants to increase the number of grid nodes, change the dimension statement of the variables WELL, WELL_ST and STORE in the source codes.

TABLE 6.2

OPTION 1 INPUT DECK

LINE	VARIABLE(S)
1	TEXT1
2	TEXT2
3	TEXT3
4	PTOP
5	HTOP
6	QTOP
7	XCTOP
8	LENGTH
9	THCON
10	RHOR
11	HCAP
12	TIME
13	NUSEC
14	SECL(i), RAD(i), EPS(i), DELZ(i), DEV(i)
:	: : : : :
13+NUSEC	SECL(NUSEC), RAD(NUSEC), EPS(NUSEC), DELZ(NUSEC), DEV(NUSEC)
14+NUSEC	NUPO
15+NUSEC	T_DEPTH(i), TEMP(i)
:	: :
14+NUSEC+NUPO	T_DEPTH(NUPO), TEMP(NUPO)
15+NUSEC+NUPO	NUFEED
16+NUSEC+NUPO	F_DEPTH(i), FLOW(i), ENTH(i), XC(i)
:	: : : :
15+NUSEC+NUPO+NUFEED	F_DEPTH(NUFEED-1), FLOW(NUFEED-1), ENTH(NUFEED-1), XC(NUFEED-1)

NOTE: For simulator HOLA, leave Line 7 blank and from Line 16+NUSEC+NUPO to Line 15+NUSEC+NUPO+NUFEED omit the variable XC

TABLE 6.3

OPTION 2 INPUT DECK

LINE	VARIABLE(S)
1	TEXT1
2	TEXT2
3	TEXT3
4	PTOP
5	HTOP
6	QTOP
7	XCTOP
8	LENGTH
9	THCON
10	RHOR
11	HCAP
12	TIME
13	NUSEC
14	SECL(i), RAD(i), EPS(i), DELZ(i), DEV(i)
:	: : : : :
:	: : : : :
13+NUSEC	SECL(NUSEC), RAD(NUSEC), EPS(NUSEC), DELZ(NUSEC), DEV(NUSEC)
14+NUSEC	NUPO
15+NUSEC	T_DEPTH(i), TEMP(i)
:	: :
:	: :
14+NUSEC+NUPO	T_DEPTH(NUPO), TEMP(NUPO)
15+NUSEC+NUPO	NUFEED
16+NUSEC+NUPO	F_DEPTH(i), RESV91,i), RESV(3,i), RESV(4,i), RESV(6,i)
:	: : : :
:	: : : :
16+NUSEC+NUPO+NUFEED	F_DEPTH(NUFEED), RESV(1,NUFEED), RESV(3,NUFEED), RESV(4,NUFEED), RESV(6,NUFEED)

NOTE: For simulator HOLA, leave Line 7 blank and from Line 16+NUSEC+NUPO to Line 16+NUSEC+NUPO+NUFEED omit the variable RESV(6,i). Also, the simulators can compute for the expected fluid composition at the wellhead, the value 0 (or any value) can be entered in Line 7 for simulators GWELL and GWNACL.

The input variables and their units are tabulated below.

TABLE 6.4
DESCRIPTION OF THE INPUT VARIABLES

VARIABLE	UNIT	REMARKS
DELZ(i)	m	Distance between two adjacent grid nodes for pipe section i
DEV(i)	degree (°)	Deviation angle measured from horizontal for pipe section i
ENTH(i)	°C or J/kg	Temperature or enthalpy of fluid at feedzone i
EPS(i)	m	Pipe roughness of section i
FLOW(i)	kg/s	Flow rate at feedzone i; + means producing (For Option 1 only) - means injecting
F_DEPTH(i)	m	Depth of feedzone i
HCAP	J/kg-°C	Heat capacity
HTOP	°C or J/kg	Option 1: Wellhead fluid temperature or enthalpy Option 2: Bottomhole pressure
LENGTH	m	Well measured depth
NUFEED		Number of feedzones; max. = 10
NUPO		Number of reservoir temperature data points max. = 20
NUSEC		Number of pipe sections; max. = 50
PTOP	Pa abs	Wellhead pressure
QTOP	kg/s	Option 1: Wellhead flow rate
	Pa abs	Option 2: Max. error in wellhead pressure (difference between required and calculated wellhead pressures)
RAD(i)	m	Pipe radius
RESV(1,i)	Pa abs	Reservoir Pressure (For Option 2 only)
RESV(3,i)	°C or J/kg	Temperature or enthalpy of fluid at feedzone i (For Option 2 only)
RESV(4,i)	m ³	Productivity index of feedzone i; see Eqn. 3.13 for definition (For Option 2 only)
RESV(6,i)		Mass fraction of CO ₂ or NaCl of feedzone i
TEXT1		Character string; max. length = 80

VARIABLE	UNIT	REMARKS
TEXT2		Character string; max. length = 80
TEXT3		Character string; max. length = 80
THCON	W/m-°C	Thermal conductivity
TIME	s	Time since initial discharge
T_DEPTH(i)	m	Depth of temperature data point i
XC(i)		Mass fraction CO ₂ or NaCl of fluid at feedzone i
XCTOP		Mass fraction in total discharge of CO ₂ or NaCl at the wellhead Note that for Option 2, the fluid composition at the wellhead can be calculated. For Option 2, XCTOP may not be specified

REFERENCES

- Ahsanullah, A.K.M.; "Temperature Variation of Surface Tension of Water." Proc. Pakistan Acad. Sci., Vol. 9, No. 2, pp. 97-108, 1972.
- Ahsanullah, A.K.M.; "Temperature Variation of Surface Tension of Water-NaCl System, and Discussion of Origin of Discontinuity Observed in Pure Liquids and Solutions." Proc. Pakistan Acad. Sci., Vol. 9, No. 2, pp. 119-129, 1972.
- Aunzo, Z.P.; "GWELL: A Multi-Component Multi-Feedzone Geothermal Wellbore Simulator." M.S. Thesis, University of California at Berkeley, Berkeley, CA., USA, May, 1990.
- Barelli, A., Corsi, R., Del Pizzo, G. and Scali, C.; "A Two-Phase Flow Model for Geothermal Wells in the Presence of Non-Condensable Gas." Geothermics, Vol. 11, No. 3, pp. 175-191, 1982.
- Beggs, H.D.; "An Experimental Study of Two-Phase in Inclined Pipes." Ph.D. Dissertation, University of Tulsa, Oklahoma, USA, 1972.
- Bjornsson, G.; "A Multi-Feedzone Geothermal Wellbore Simulator." Earth Sciences Division, Lawrence Berkeley Laboratory Report LBL-23546, Berkeley, CA., USA, May 1987.
- Bodvarsson, G.S., Pruess, K. and Lippmann, M.J.; "Modelling of Geothermal Systems." Journal of Petroleum Technology, September, 1986, pp. 1007-1021.
- Buff, F.P. and Stillinger, F.H., Jr.; "Surface Tension of Ionic Solutions." The Jour. of Chem. Phys., Vol. 25, No. 2, pp. 312-318, 1956.
- Burden, L.B., Faires, J.D. and Reynolds, A.C.; "Numerical Analysis." 2nd Edition, Prindle, Weber and Schimdt, Boston, USA, 1981.
- Butler, J.N.; "Carbon Dioxide Equilibria and Their Applications." Addison-Wesley Publishing Company, Inc., 1982.

- Carslaw, H.S. and Jaeger, J.C.; "Conduction of Heat in Solids." Oxford University Press, 2nd Edition, 1959.
- Catigtig, D.C.; "Boreflow Simulation and Its Application to Geothermal Well Analysis and Reservoir Assessment." UNU Geothermal Training Programme, Report No. 1983-8, Iceland, 1983.
- Chisholm, D.; "Pressure Gradients due to Friction During the Flow of Evaporating Two-Phase Mixtures in Smooth Tubes and Channels." Int. J. Heat Mass Transfer, Vol. 16, pp. 347-358, 1973.
- Conte, S.D. and De Boor, C.; "Elementary Numerical Analysis." McGraw-Hill Book Company, 3rd, 1980.
- Dittman, G.L.; "Calculation of Brine Properties." Lawrence Livermore Laboratory Report No. UCID-17406, Livermore, CA, USA, February, 1977.
- Dittman, G.L.; "Wellflow for Geothermal Wells - Description of a Computer Program Including the Effects of Brine Composition." Lawrence Livermore Laboratory Report UCID-17473, Livermore, CA., May, 1977.
- Dorn, W.S. and McCracken, D.D.; "Numerical Methods with FORTRAN IV Case Studies." John Wiley and Sons, Inc., 1972.
- Ellis, A.J. and Golding, R.M.; "The Solubility of Carbon Dioxide Above 100°C in Water and in Sodium Chloride Solutions." American Journal of Science, Vol. 261, pp. 47-60, January, 1963.
- Engineering Science Data; "The Gravitational Component of Pressure Gradient for Two-Phase Gas or Vapour/Liquid Flow Through Straight Pipes." Engineering Science Data Item No. 77016, 1977.
- Freeston, D.H. and Hadgu, T.; "Modelling of Geothermal Wells with Multiple Feed Points: A Preliminary Study." Proc. 9th New Zealand Geothermal Workshop, 1987.

- Gaulke, S.W.; "The Effect of CO₂ on Reservoir Behavior for Geothermal Systems." Earth Sciences Division, Lawrence Berkeley Laboratory Report LBL-22720, Berkeley, CA., USA, December, 1986.
- Gittens, G.J.; "Variation of Surface Tension of Water with Temperature." Journal of Colloid and Interface Science, Vol. 30, No. 3, pp. 406-412, July, 1969.
- Gould, T.L.; "Vertical Two-Phase Steam-Water Flow in Geothermal Wells." Jour. Pet. Tech., pp. 833-842, August, 1974.
- Gould, T.L., Rasin Tek, M. and Katz, D.L.; "Two-Phase Flow Through Vertical, Inclined, or Curved Pipe." Jour. Pet. Tech., Vol. 257, pp. 915-926, August, 1974.
- Haas, J.L. Jr.; "Physical Properties of the Coexisting Phase and Thermophysical Properties of the H₂O Component in Boiling NaCl Solutions." Preliminary Steam Tables for NaCl Solutions, Geological Survey Bulletin 1421-A, United States Government Printing Office, Washington, USA, 1976.
- Hadgu, T., Freeston, D.H. and O'Sullivan, M.J.; "Studies of the Flow in the Liner of a Geothermal Well." Trans. Geothermal Resources Council, Vol. 12, pp. 461-468, October, 1988.
- Haywood, R.W., Knights, G.A., Middleton, G.F. and Thom, J.R.S.; "Experimental Study of the Flow Conditions and Pressure Drop of Steam-Water Mixtures at High Pressures in Heated and Unheated Tubes." Proc. Instn. Mech. Engrs., 175(13), pp. 669-726, 1961.
- Heuer, G.J.; "Interfacial Tension of Water Against Hydrocarbon and Other Gases and Adsorption of Methane on Solids at Reservoir Temperatures and Pressures." Ph.D. Dissertation, University of Texas, Austin, Texas, USA, June, 1957.
- Horvath, A.L.; "Handbook of Aqueous Electrolyte Solutions. Physical Properties, Estimation and Correlation Methods." Ellis Horwood Limited, England, 1985.

- Hough, E.W., Heuer, G.J. and Walker, J.W.; "An Improved Pendant Drop, Interfacial Tension Apparatus and Data for Carbon Dioxide and Water." Petroleum Transactions, AIME, Vol. 216, pp. 469-472, 1959.
- Jho, C., Nealon, D., Shogbola, S. and King, A.D., Jr.; "Effect of Pressure on the Surface Tension of Water: Adsorption of Hydrocarbon Gases and Carbon Dioxide on Water at Temperatures Between 0 and 50°C." Journal of Colloid and Interface Science, Vol. 65, No. 1, pp. 141-154, June, 1978.
- Kestin, J., Sengers, J.V., Parsi-Kamgar, B. and Levelt Sengers, J.M.H.; "Thermophysical Properties of Fluid H₂O." J. Phys. Chem. Ref. Data, Vol. 13, No. 1, pp. 175-183, 1984.
- Lombardi, C. and Ceresa, I.; "A Generalized Pressure Drop Correlation in Two-Phase Flow." Energia Nucleare, Vol. 25, No. 4, pp. 181-198, April, 1978.
- Martinelly, R.C. and Nelson, D.B.; "Prediction of Pressure Drop During Forced Circulation of Boiling Water." Trans. Amer. Soc. Mech. Engrs., 70(6), pp. 695-702, 1948.
- Miller, C.W.; "Wellbore User's Manual." Earth Sciences Division, Lawrence Berkeley Laboratory Report No. LBL-10910, Berkeley, CA., January, 1980.
- Mukherjee, H.; "An Experimental Study of Inclined Two-Phase Flow." Ph.D. Dissertation, University of Tulsa, Oklahoma, USA, 1979.
- Orkiszewski, J.; "Predicting Two-Phase Pressure Drop in Vertical Pipes." Jour. Pet. Tech., pp. 829-838, June, 1967.
- Parlactuna, M.; "Two-Phase Wellbore Simulator and Analysis of Reinjection Data from Svartsengi, Iceland." The UNU Geothermal Training Programme, Iceland, Report No. 1985-7, 1985.

- Phillips, S.L., Igbene, A., Fair, J.A., Ozbek, H. and Tavana, M.; "A Technical Databook for Geothermal Energy Utilization." Lawrence Berkeley Laboratory Report No. LBL-12810, Berkeley, CA, USA, June, 1981.
- Phillips, S.L., Ozbek, H. and Silvester, L.F.; "Density of Sodium Chloride Solutions at High Temperatures and Pressures." Lawrence Berkeley Laboratory Report LBL-16275, Berkeley, CA, USA, June, 1983.
- Pitzer, K.S.; "The Thermodynamics of Sodium Chloride Solutions in Steam." Lawrence Berkeley Laboratory Report LBL-14886, Berkeley, CA, USA, August, 1982.
- Pitzer, K.S.; "Thermodynamic Properties of Aqueous NaCl from 273 to 823 °K with Estimates for Higher Temperatures." Lawrence Berkeley Laboratory Report LBL-18183, Berkeley, CA, USA, July, 1984.
- Potter, R.W. II and Brown, D.L.; "The Volumetric Properties of Aqueous Sodium Chloride Solutions from 0° to 500°C at Pressures up to 2000 Bars Based on a Regression of Available Data in the Literature." Preliminary Steam Tables for NaCl Solutions, Geological Survey Bulletin 1421-C, United States Government Printing Office, Washington, 1976.
- Pritchett, J.W., Rice, M.H. and Riney, T.D.; "Equation-of-State for Water-Carbon Dioxide Mixtures: Implications for Baca Reservoir." DOE/ET/27163-8, 1981.
- Pruess, K.; "TOUGH User's Guide." Lawrence Berkeley Laboratory Report LBL-20700, Berkeley, CA, USA, April, 1986.
- Sourirajan, S. and Kennedy, G.C.; "The System H₂O-NaCl at Elevated Temperatures and Pressures." Amer. Jour. of Science, Vol. 260, pp. 115-141, February, 1962.
- Sutton, F.M.; "Pressure-Temperature Curves for a Two-Phase Mixture of Water and Carbon Dioxide." New Zealand Journal of Science, Vol. 19, pp. 297-301, 1976.
- Sutton, F.M. and McNabb, A.; "Boiling Curves at Broadlands Geothermal Field, New Zealand." New Zealand Journal of Science, Vol. 20, pp. 333-337, 1976.

- Sweigert, R.L., Wever, P. and Allen, R.L.; "Thermophysical Properties of Gases. Carbon Dioxide." *Industrial and Engineering Chemistry*, 38, (2), pp.185-200, 1946.
- Takenouchi, S. and Kennedy, G.C.; "The Binary System H₂O-CO₂ at High Temperatures and Pressures." *Am. J. Sci.*, Vol. 262, p. 1055, 1964.
- Unterberg, W.; "Thermophysical Properties of Aqueous Sodium Chloride Solutions." UCLA Department of Engineering Report No. 64-21, Los Angeles, CA, USA, May, 1964.
- Upadhyay, R.N., Hartz, J.D., Tomkoria, B.N. and Gulati, M.S.; "Comparison of Calculated and Observed Pressure Drops in Geothermal Wells Producing Steam-Water Mixtures." *Proc. 52nd Annual Fall Technical Conference and Exhibition of the Soc. of Pet. Engrs. of AIME*, Denver, Colorado, USA, SPE-6766, 1977.
- Vargaftik, N.B., Volkov, B.N. and Voljak, L.D.; "International Tables of the Surface Tension of Water." *J. Phys. Chem. Ref. Data*, Vol. 12, No. 3, pp. 817-820, 1983.
- Vukalovich, M.P. and Altunin, V.V.; "Thermophysical Properties of Carbon Dioxide." Collet's (Publisher) Ltd., London and Wellingborough, 1968.
- Wahl, E.F.; "Geothermal Energy Utilization." John Wiley and Sons, Inc., pp. 60-63, 1977.
- Wallis, G.B.; "One-Dimensional Two-Phase Flow." McGraw-Hill, USA, 1969.
- Weres, O., Peiper, J.C. and Pitzer, K.S.; "Documentation for Computer Code NaCl." Lawrence Berkeley Laboratory Report No. LBL-21859, Berkeley, CA, USA, February, 1987.
- White, F.M.; "Fluid Mechanics." McGraw-Hill, USA, 1979.

FIGURES

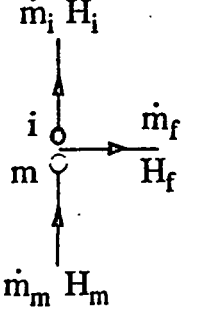
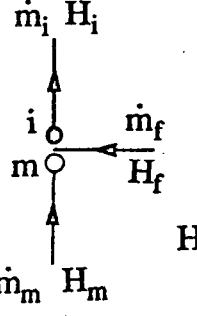
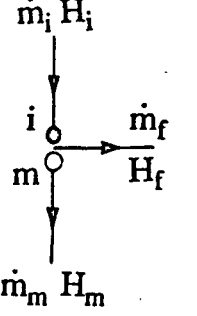
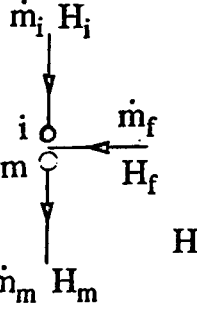
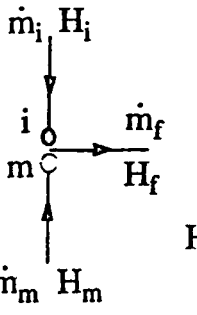
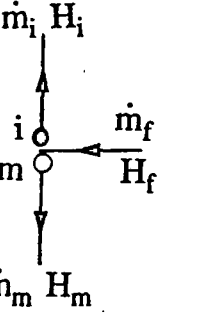
<p>Case 1 $\dot{m}_i > 0 > \dot{m}_f$</p>  <p>$\dot{m}_m = \dot{m}_i - \dot{m}_f$</p> <p>$H_m = H_i = H_f$</p>	<p>Case 4 $\dot{m}_i > \dot{m}_f > 0$</p>  <p>$\dot{m}_m = \dot{m}_i - \dot{m}_f$</p> <p>$H_m = \frac{H_i \dot{m}_i - H_f \dot{m}_f}{\dot{m}_m}$</p>
<p>Case 2 $\dot{m}_i < \dot{m}_f < 0$</p>  <p>$\dot{m}_m = \dot{m}_i - \dot{m}_f$</p> <p>$H_m = H_i = H_f$</p>	<p>Case 5 $\dot{m}_f > 0 > \dot{m}_i$</p>  <p>$\dot{m}_m = \dot{m}_i - \dot{m}_f$</p> <p>$H_m = \frac{H_i \dot{m}_i - H_f \dot{m}_f}{\dot{m}_m}$</p>
<p>Case 3 $\dot{m}_f < \dot{m}_i < 0$</p>  <p>$\dot{m}_m = \dot{m}_i - \dot{m}_f$</p> <p>$H_m = \frac{H_i \dot{m}_i - H_f \dot{m}_f}{\dot{m}_m}$</p>	<p>Case 6 $\dot{m}_f > \dot{m}_i > 0$</p>  <p>$\dot{m}_m = \dot{m}_i - \dot{m}_f$</p> <p>$H_m = H_i = H_f$</p>

Figure 2.1 Possible flow configurations that can occur at a feedzone (modified after Bjornsson, 1987).

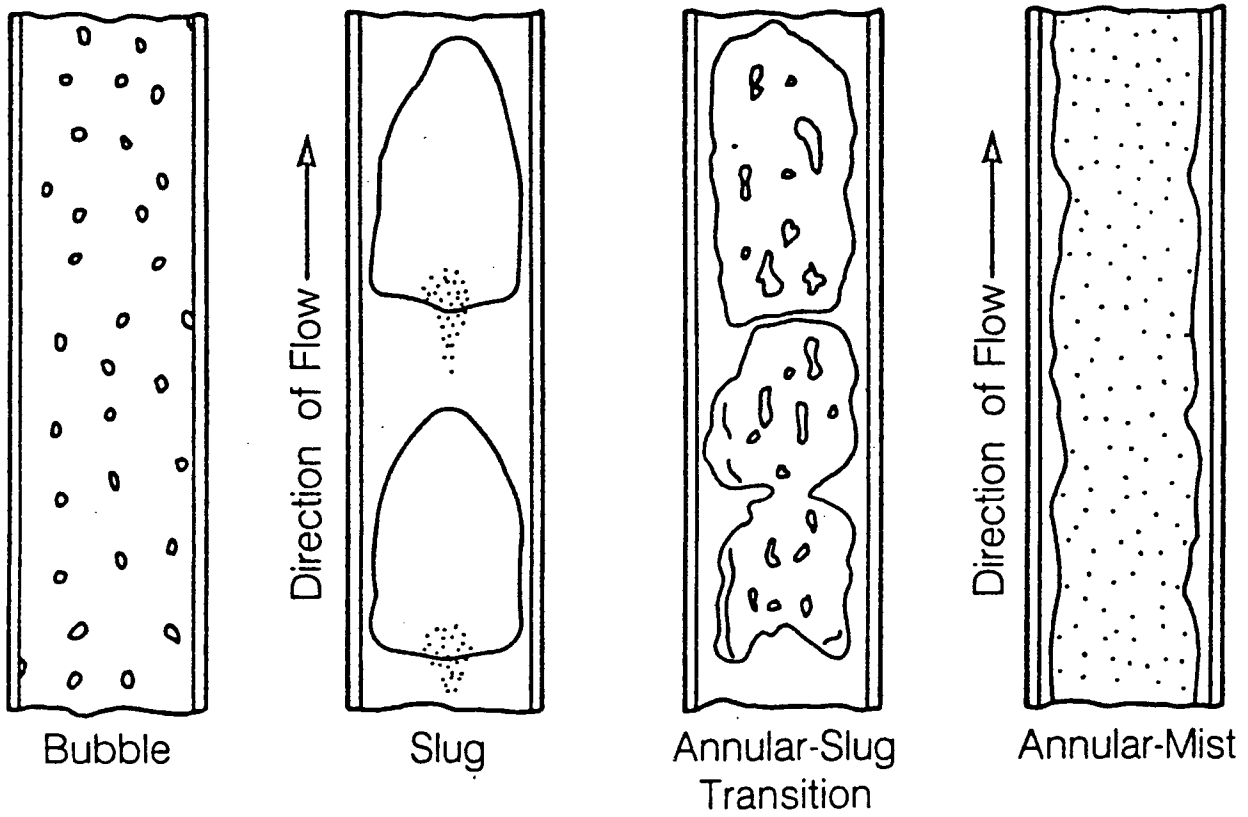


Figure 4.1 Illustration of the different flow regimes (after Orkiszewski, 1967).

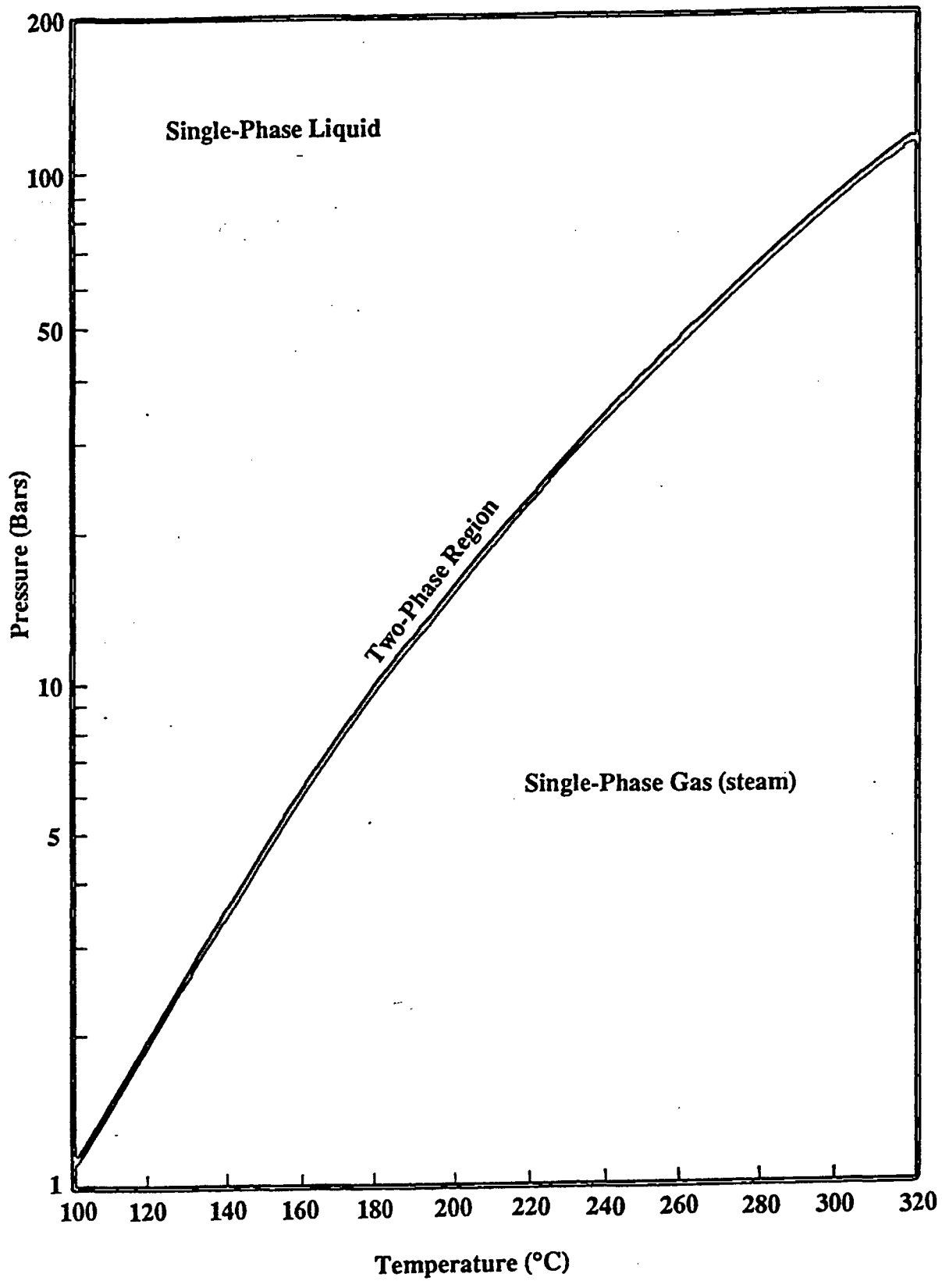


Figure 5.1 Saturation curve for H₂O (after Pritchett et al., 1981).

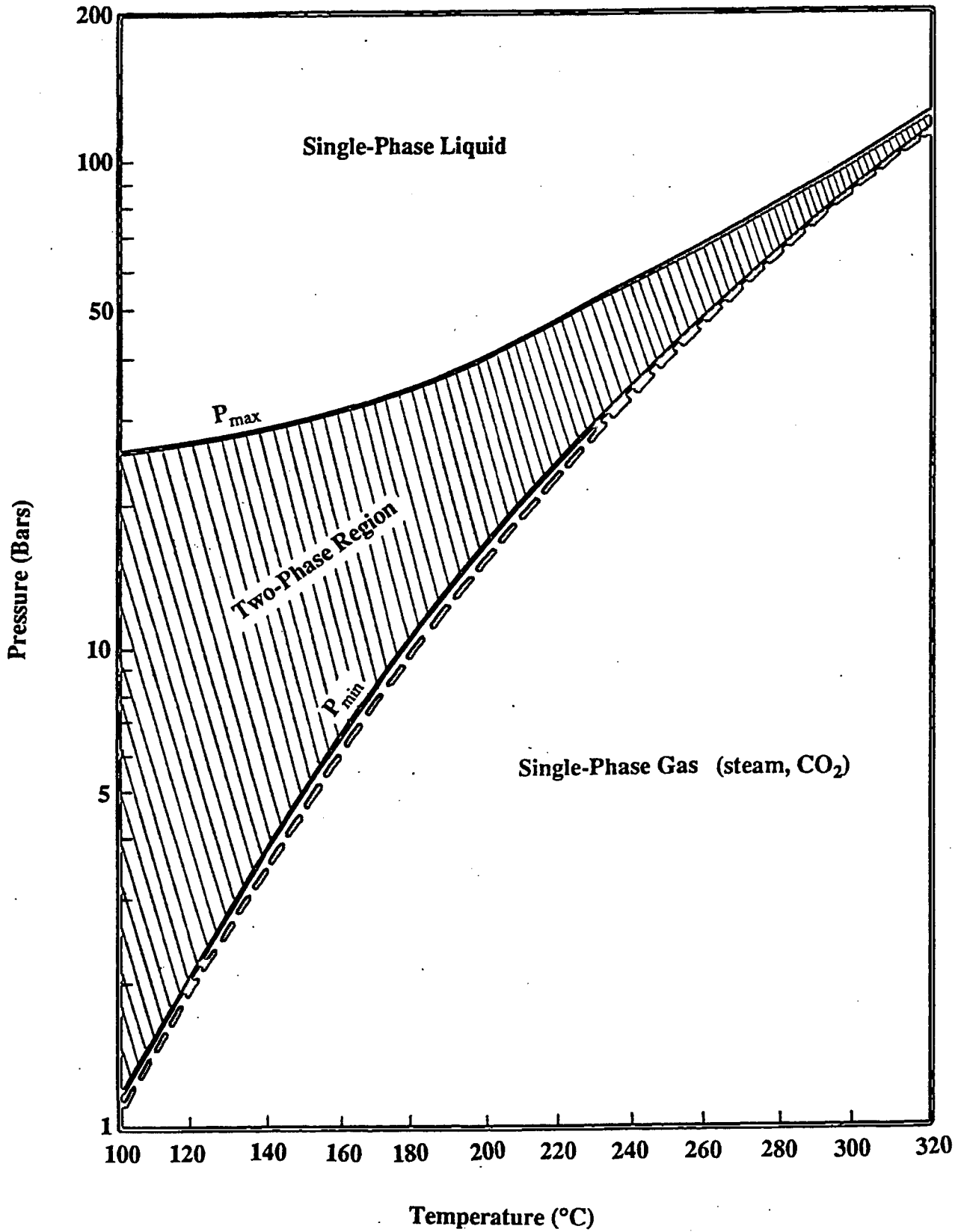


Figure 5.2 Saturation curve for H₂O-CO₂ system with 1% CO₂ (after Pritchett et al., 1981).

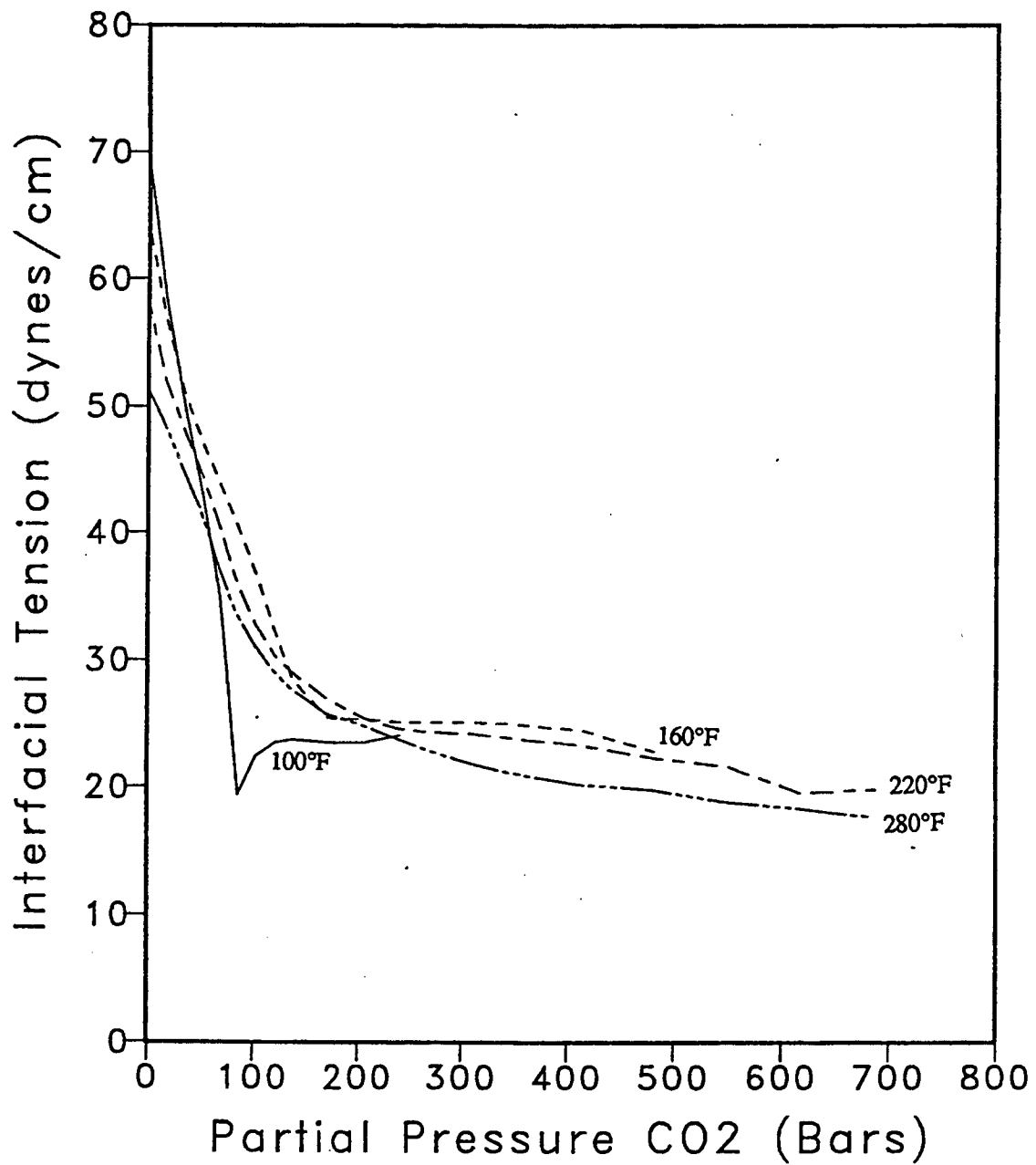


Figure 5.3 Effect of CO₂ on the surface tension of H₂O at different temperatures.

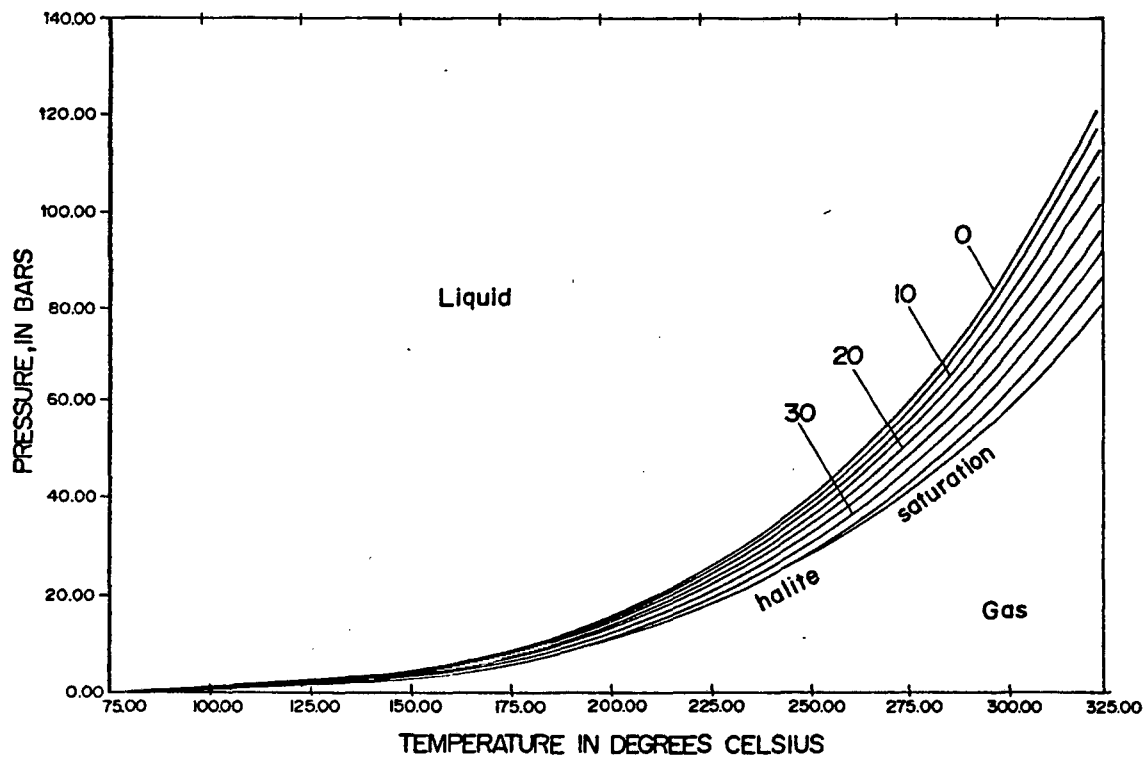


Figure 5.4 Saturation curve for H₂O-NaCl system (after Haas, 1976).

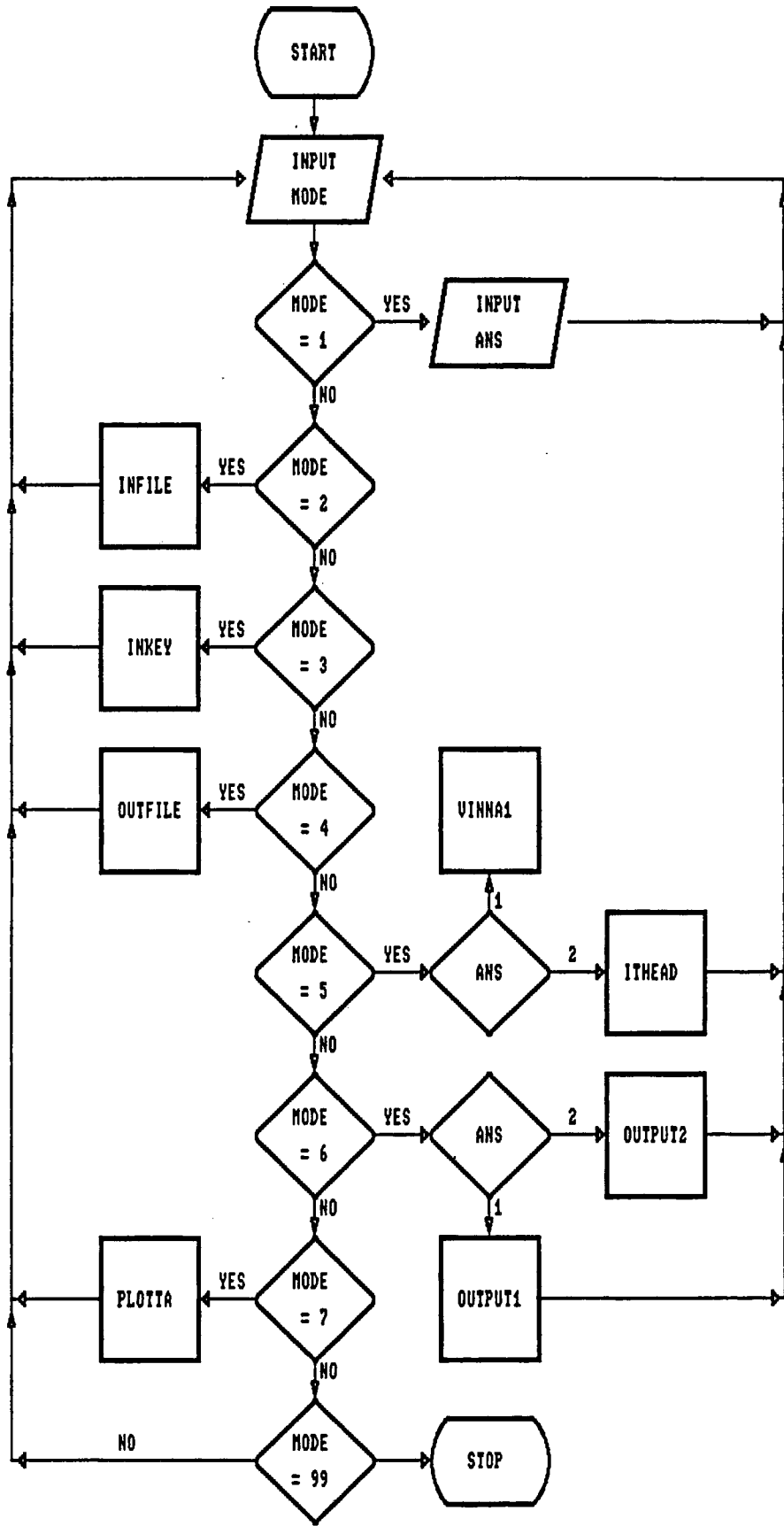


Figure 6.1 Simplified flowchart.

APPENDIX A
(SAMPLE RUNS FOR GWELL)

SAMPLE 1 INPUT FILE

```

Sample 1 for Simulator GWELL
- Option 1 used -
- The well is producing two-phase fluid at the wellhead -
0.7000E+06
161.0
100.0000
0.03
2530.000
0.000
2800.000
1000.000
6.0480E+05
20
  300.0  0.1102  4.6E-5    25.0   90.0
    30.0  0.1102  4.6E-5    15.0   88.0
    30.0  0.1102  4.6E-5    15.0   86.0
    30.0  0.1102  4.6E-5    15.0   84.0
    30.0  0.1102  4.6E-5    15.0   82.0
    30.0  0.1102  4.6E-5    15.0   80.0
    30.0  0.1102  4.6E-5    15.0   78.0
    30.0  0.1102  4.6E-5    15.0   76.0
    30.0  0.1102  4.6E-5    15.0   74.0
    30.0  0.1102  4.6E-5    15.0   72.0
    30.0  0.1102  4.6E-5    15.0   70.0
    30.0  0.1102  4.6E-5    15.0   68.0
    30.0  0.1102  4.6E-5    15.0   66.0
    30.0  0.1102  4.6E-5    15.0   64.0
    30.0  0.1102  4.6E-5    15.0   62.0
    30.0  0.1102  4.6E-5    15.0   60.0
   150.0  0.1102  4.6E-5    25.0   60.0
    10.0  0.1102  4.6E-5    10.0   60.0
  1600.0  0.0873  1.5E-5    25.0   60.0
    20.0  0.0873  1.5E-5    20.0   60.0
4
  0.0    25.00
 1000.0  260.00
 2000.0  310.00
 2500.0  330.00
3
 1110.0  20.00    1.7000E+06  0.10
 1810.0  40.00    1.2000E+06  0.02

```

SAMPLE 1 GWELL.LOG FILE

```

Two phase to water phase
Temperature      X2      Depth
0.271164E+03   -0.00095425   1310.0

```

SAMPLE 1 OUTPUT FILE

GWELL - MODEL RESULTS

Sample 1 for Simulator GWELL

- Option 1 used -

- The well is producing two-phase fluid at the wellhead -

Wellhead pressure (bar abs.) : 7.00
 Wellhead temperature (C) : 161.00
 Wellhead dryness : 0.316
 Wellhead enthalpy (kJ/kg) : 1258.92
 Wellhead total flow (kg/s) : 100.00
 Wellhead CO2 : 0.0300

64

Feedzone no:	Depth (m)	Flow (kg/s)	Enthalpy (kJ/kg)	XC02
1	1110.0	20.0000	1700.0	0.1000
2	1810.0	40.0000	1200.0	0.0200
3	2530.0	40.0000	1180.2	0.0050

Depth (m)	Press (Pa)	Temp (C)	Dryness	Hw (J/kg)	Hs (J/kg)	Vw (m/s)	Vs (m/s)	Dw (kg/m ³)	Ds (kg/m ³)	H_t (J/kg)	Rad (m)	Reg	XC02
0.0	700000.	161.00	0.31592	679670.	2513235.	165.63	202.19	906.28	4.14	1258922.	0.110	Mi	0.030
25.0	1122540.	180.21	0.28934	763764.	2510816.	102.21	118.61	886.68	6.53	1269261.	0.110	Mi	0.030
50.0	1294425.	186.34	0.27974	790886.	2507513.	87.52	100.24	880.07	7.50	1271090.	0.110	Tr	0.030
75.0	1436944.	190.94	0.27226	811325.	2504188.	77.89	88.41	874.99	8.30	1272228.	0.110	Tr	0.030
100.0	1562217.	194.68	0.26602	828030.	2500922.	70.82	79.85	870.78	9.01	1273056.	0.110	Sl	0.030
125.0	1675801.	197.87	0.26061	842301.	2497730.	65.31	73.23	867.14	9.66	1273714.	0.110	Sl	0.030
150.0	1780811.	200.66	0.25578	854842.	2494611.	60.82	67.89	863.91	10.26	1274269.	0.110	Sl	0.030
175.0	1879207.	203.16	0.25142	866083.	2491559.	57.07	63.45	860.99	10.82	1274755.	0.110	Sl	0.030
200.0	1972318.	205.42	0.24741	876308.	2488567.	53.86	59.68	858.31	11.35	1275193.	0.110	Sl	0.030
225.0	2061098.	207.50	0.24369	885715.	2485628.	51.08	56.42	855.82	11.86	1275596.	0.110	Sl	0.030

250.0	2146260.	209.43	0.24021	894447.	2482737.	48.62	53.56	853.50	12.35	1275973.	0.110	SI	0.030
275.0	2228355.	211.22	0.23694	902613.	2479888.	46.43	51.03	851.31	12.82	1276330.	0.110	SI	0.030
300.0	2307816.	212.91	0.23384	910297.	2477075.	44.46	48.75	849.24	13.28	1276671.	0.110	SI	0.030
315.0	2354364.	213.88	0.23205	914704.	2475404.	43.37	47.50	848.05	13.55	1276869.	0.110	SI	0.030
330.0	2400157.	214.81	0.23032	918973.	2473744.	42.34	46.31	846.89	13.81	1277063.	0.110	SI	0.030
345.0	2445236.	215.72	0.22863	923114.	2472094.	41.37	45.19	845.76	14.07	1277254.	0.110	SI	0.030
360.0	2489669.	216.60	0.22698	927137.	2470453.	40.44	44.13	844.66	14.33	1277441.	0.110	SI	0.030
375.0	2533473.	217.45	0.22537	931050.	2468821.	39.56	43.12	843.59	14.59	1277625.	0.110	SI	0.030
390.0	2576720.	218.28	0.22381	934860.	2467197.	38.72	42.17	842.54	14.84	1277806.	0.110	SI	0.030
405.0	2619405.	219.09	0.22227	938573.	2465581.	37.92	41.25	841.52	15.09	1277984.	0.110	SI	0.030
420.0	2661607.	219.88	0.22077	942197.	2463972.	37.15	40.38	840.52	15.33	1278160.	0.110	SI	0.030
435.0	2703299.	220.65	0.21930	945734.	2462371.	36.42	39.55	839.54	15.58	1278334.	0.110	SI	0.030
450.0	2744571.	221.40	0.21786	949193.	2460774.	35.72	38.76	838.58	15.82	1278505.	0.110	SI	0.030
465.0	2785375.	222.13	0.21645	952572.	2459186.	35.05	37.99	837.63	16.06	1278674.	0.110	SI	0.030
480.0	2825809.	222.35	0.21506	955883.	2457601.	34.40	37.26	836.71	16.29	1278842.	0.110	SI	0.030
495.0	2865808.	223.55	0.21370	959121.	2456023.	33.78	36.56	835.80	16.53	1279007.	0.110	SI	0.030
510.0	2905482.	224.24	0.21236	962299.	2454449.	33.18	35.88	834.91	16.76	1279171.	0.110	SI	0.030
525.0	2944745.	224.91	0.21104	965409.	2452881.	32.61	35.23	834.03	16.99	1279332.	0.110	SI	0.030
540.0	2983722.	225.57	0.20975	968465.	2451316.	32.05	34.61	833.17	17.22	1279493.	0.110	SI	0.030
555.0	3022305.	226.22	0.20848	971459.	2449758.	31.51	34.01	832.32	17.45	1279651.	0.110	SI	0.030
570.0	3060637.	226.86	0.20722	974403.	2448201.	31.00	33.42	831.49	17.68	1279808.	0.110	SI	0.030
585.0	3098586.	227.48	0.20599	977290.	2446651.	30.50	32.86	830.67	17.90	1279962.	0.110	SI	0.030
600.0	3136313.	228.09	0.20477	980131.	2445103.	30.01	32.32	829.86	18.12	1280116.	0.110	SI	0.030
615.0	3173665.	228.69	0.20357	982918.	2443561.	29.54	31.80	829.06	18.35	1280267.	0.110	SI	0.030
630.0	3210821.	229.28	0.20239	985664.	2442020.	29.09	31.29	828.28	18.57	1280417.	0.110	SI	0.030
645.0	3247606.	229.86	0.20123	988358.	2440486.	28.65	30.80	827.51	18.78	1280565.	0.110	SI	0.030
660.0	3284216.	230.43	0.20008	991014.	2438953.	28.23	30.32	826.74	19.00	1280712.	0.110	SI	0.030
675.0	3320455.	230.99	0.19894	993621.	2437426.	27.81	29.86	825.99	19.22	1280856.	0.110	SI	0.030
690.0	3356540.	231.54	0.19782	996193.	2435900.	27.41	29.41	825.25	19.43	1281000.	0.110	SI	0.030
705.0	3392250.	232.08	0.19672	998718.	2434382.	27.02	28.98	824.52	19.65	1281141.	0.110	SI	0.030
720.0	3427823.	232.62	0.19563	1001211.	2432863.	26.65	28.56	823.80	19.86	1281281.	0.110	SI	0.030
735.0	3463017.	233.14	0.19455	1003657.	2431352.	26.28	28.15	823.09	20.07	1281419.	0.110	SI	0.030
750.0	3498088.	233.66	0.19349	1006074.	2429841.	25.92	27.76	822.39	20.28	1281556.	0.110	SI	0.030
775.0	3556292.	234.50	0.19173	1010043.	2427319.	25.35	27.12	821.23	20.63	1281784.	0.110	SI	0.030
800.0	3614215.	235.34	0.19001	1013941.	2424793.	24.79	26.51	820.09	20.98	1282011.	0.110	SI	0.030
825.0	3777165.	237.61	0.18506	1024600.	2417288.	5.03	45.94	816.96	21.97	1282333.	0.110	SI	0.030
850.0	3985297.	240.38	0.17882	1037647.	2407309.	4.97	43.12	813.09	23.24	1282575.	0.110	SI	0.030
875.0	4197275.	243.06	0.17264	1050347.	2396872.	4.92	40.48	809.28	24.55	1282812.	0.110	SI	0.030
900.0	4413005.	245.66	0.16651	1062710.	2385972.	4.87	38.01	805.53	25.89	1283046.	0.110	SI	0.030
910.0	4500316.	246.68	0.16407	1067561.	2381482.	4.86	37.07	804.05	26.44	1283139.	0.110	SI	0.030
935.0	4704758.	248.99	0.15837	1078568.	2370585.	7.45	58.07	800.67	27.72	1283183.	0.087	SI	0.030
960.0	4981267.	251.97	0.15095	1092805.	2355698.	7.39	53.84	796.24	29.48	1283444.	0.087	SI	0.030
985.0	5259448.	254.79	0.14370	1106389.	2340267.	7.34	49.91	791.97	31.28	1283696.	0.087	SI	0.030

1010.0	5538785.	257.48	0.13661	1119334.	2324320.	7.30	46.24	787.85	33.10	1283942.	0.087	Sl	0.030
1035.0	5818600.	260.02	0.12968	1131648.	2307896.	7.27	42.81	783.89	34.95	1284182.	0.087	Sl	0.030
1060.0	6098097.	262.43	0.12293	1143332.	2291049.	7.25	39.59	780.08	36.81	1284416.	0.087	Sl	0.030
1085.0	6376409.	264.70	0.11636	1154388.	2273842.	7.24	36.58	776.44	38.70	1284647.	0.087	Sl	0.030
1110.0	6652647.	266.84	0.10999	1164817.	2256346.	7.23	33.78	772.97	40.59	1284875.	0.087	Sl	0.030
1110.0	6652647.	265.68	0.02108	1158718.	2220567.	5.45	7.62	774.85	41.06	1181106.	0.087	Sl	0.013
1135.0	6831288.	266.59	0.01776	1162962.	2196839.	5.33	6.84	773.37	42.47	1181319.	0.087	Sl	0.013
1160.0	7004521.	267.41	0.01466	1166777.	2173505.	5.21	6.18	772.03	43.86	1181533.	0.087	Sl	0.013
1185.0	7173127.	268.16	0.01176	1170218.	2150549.	5.07	5.61	770.80	45.22	1181746.	0.087	Sl	0.013
1210.0	7338836.	268.85	0.00902	1173350.	2127803.	4.92	5.18	769.67	46.58	1181959.	0.087	Bu	0.013
1235.0	7503628.	269.48	0.00640	1176231.	2105048.	4.76	4.83	768.61	47.95	1182172.	0.087	Bu	0.013
1260.0	7668261.	270.08	0.00387	1178887.	2082231.	4.60	4.51	767.63	49.34	1182385.	0.087	Bu	0.013
1285.0	7832916.	270.63	0.00144	1181334.	2059375.	4.45	4.23	766.70	50.73	1182598.	0.087	Bu	0.013
1310.0	8086022.	271.16	0.00000	1182812.	0.	4.34	0.00	769.46	0.00	1182812.	0.087	1p	0.013
1335.0	8261922.	271.22	0.00000	1183025.	0.	4.34	0.00	769.62	0.00	1183025.	0.087	1p	0.013
1360.0	8437853.	271.27	0.00000	1183237.	0.	4.34	0.00	769.78	0.00	1183237.	0.087	1p	0.013
1385.0	8613815.	271.32	0.00000	1183450.	0.	4.34	0.00	769.94	0.00	1183450.	0.087	1p	0.013
1410.0	8789808.	271.38	0.00000	1183662.	0.	4.34	0.00	770.10	0.00	1183662.	0.087	1p	0.013
1435.0	8965833.	271.43	0.00000	1183875.	0.	4.34	0.00	770.25	0.00	1183875.	0.087	1p	0.013
1460.0	9141888.	271.48	0.00000	1184087.	0.	4.34	0.00	770.41	0.00	1184087.	0.087	1p	0.013
1485.0	9317975.	271.54	0.00000	1184300.	0.	4.34	0.00	770.57	0.00	1184300.	0.087	1p	0.013
1510.0	9494092.	271.59	0.00000	1184512.	0.	4.34	0.00	770.73	0.00	1184512.	0.087	1p	0.013
1535.0	9670241.	271.64	0.00000	1184725.	0.	4.33	0.00	770.88	0.00	1184725.	0.087	1p	0.013
1560.0	9846420.	271.70	0.00000	1184937.	0.	4.33	0.00	771.04	0.00	1184937.	0.087	1p	0.013
1585.0	10022630.	271.75	0.00000	1185150.	0.	4.33	0.00	771.20	0.00	1185150.	0.087	1p	0.013
1610.0	10198871.	271.80	0.00000	1185362.	0.	4.33	0.00	771.35	0.00	1185362.	0.087	1p	0.013
1635.0	10375143.	271.86	0.00000	1185575.	0.	4.33	0.00	771.51	0.00	1185575.	0.087	1p	0.013
1660.0	10551445.	271.91	0.00000	1185787.	0.	4.33	0.00	771.67	0.00	1185787.	0.087	1p	0.013
1685.0	10727778.	271.96	0.00000	1186000.	0.	4.33	0.00	771.82	0.00	1186000.	0.087	1p	0.013
1710.0	10904142.	272.02	0.00000	1186212.	0.	4.33	0.00	771.98	0.00	1186212.	0.087	1p	0.013
1735.0	11080536.	272.07	0.00000	1186425.	0.	4.33	0.00	772.13	0.00	1186425.	0.087	1p	0.013
1760.0	11256960.	272.12	0.00000	1186637.	0.	4.33	0.00	772.29	0.00	1186637.	0.087	1p	0.013
1785.0	11433415.	272.17	0.00000	1186850.	0.	4.33	0.00	772.44	0.00	1186850.	0.087	1p	0.013
1810.0	11609900.	272.23	0.00000	1187062.	0.	4.32	0.00	772.59	0.00	1187062.	0.087	1p	0.013
1810.0	11609900.	268.74	0.00000	1174129.	0.	2.15	0.00	778.48	0.00	1174129.	0.087	1p	0.005
1835.0	11778418.	268.79	0.00000	1174341.	0.	2.15	0.00	778.62	0.00	1174341.	0.087	1p	0.005
1860.0	11946966.	268.84	0.00000	1174554.	0.	2.15	0.00	778.76	0.00	1174554.	0.087	1p	0.005
1885.0	12115542.	268.89	0.00000	1174766.	0.	2.14	0.00	778.90	0.00	1174766.	0.087	1p	0.005
1910.0	12284147.	268.94	0.00000	1174979.	0.	2.14	0.00	779.04	0.00	1174979.	0.087	1p	0.005
1935.0	12452782.	268.99	0.00000	1175191.	0.	2.14	0.00	779.18	0.00	1175191.	0.087	1p	0.005
1960.0	12621445.	269.04	0.00000	1175404.	0.	2.14	0.00	779.32	0.00	1175404.	0.087	1p	0.005
1985.0	12790138.	269.09	0.00000	1175616.	0.	2.14	0.00	779.46	0.00	1175616.	0.087	1p	0.005
2010.0	12958859.	269.14	0.00000	1175829.	0.	2.14	0.00	779.60	0.00	1175829.	0.087	1p	0.005
2035.0	13127610.	269.19	0.00000	1176041.	0.	2.14	0.00	779.74	0.00	1176041.	0.087	1p	0.005

2060.0	13296389.	269.24	0.00000	1176254.	0.	2.14	0.00	779.88	0.00	1176254.	0.087	1p	0.005
2085.0	13465197.	269.29	0.00000	1176466.	0.	2.14	0.00	780.01	0.00	1176466.	0.087	1p	0.005
2110.0	13634034.	269.34	0.00000	1176679.	0.	2.14	0.00	780.15	0.00	1176679.	0.087	1p	0.005
2135.0	13802900.	269.39	0.00000	1176891.	0.	2.14	0.00	780.29	0.00	1176891.	0.087	1p	0.005
2160.0	13971794.	269.44	0.00000	1177104.	0.	2.14	0.00	780.43	0.00	1177104.	0.087	1p	0.005
2185.0	14140717.	269.49	0.00000	1177316.	0.	2.14	0.00	780.56	0.00	1177316.	0.087	1p	0.005
2210.0	14309669.	269.54	0.00000	1177529.	0.	2.14	0.00	780.70	0.00	1177529.	0.087	1p	0.005
2235.0	14478649.	269.59	0.00000	1177741.	0.	2.14	0.00	780.84	0.00	1177741.	0.087	1p	0.005
2260.0	14647658.	269.64	0.00000	1177954.	0.	2.14	0.00	780.98	0.00	1177954.	0.087	1p	0.005
2285.0	14816695.	269.69	0.00000	1178166.	0.	2.14	0.00	781.11	0.00	1178166.	0.087	1p	0.005
2310.0	14985761.	269.74	0.00000	1178379.	0.	2.14	0.00	781.25	0.00	1178379.	0.087	1p	0.005
2335.0	15154855.	269.78	0.00000	1178591.	0.	2.14	0.00	781.39	0.00	1178591.	0.087	1p	0.005
2360.0	15323978.	269.83	0.00000	1178804.	0.	2.14	0.00	781.52	0.00	1178804.	0.087	1p	0.005
2385.0	15493129.	269.88	0.00000	1179016.	0.	2.14	0.00	781.66	0.00	1179016.	0.087	1p	0.005
2410.0	15662308.	269.93	0.00000	1179229.	0.	2.14	0.00	781.79	0.00	1179229.	0.087	1p	0.005
2435.0	15831516.	269.98	0.00000	1179441.	0.	2.14	0.00	781.93	0.00	1179441.	0.087	1p	0.005
2460.0	16000752.	270.03	0.00000	1179654.	0.	2.14	0.00	782.06	0.00	1179654.	0.087	1p	0.005
2485.0	16170016.	270.08	0.00000	1179866.	0.	2.14	0.00	782.20	0.00	1179866.	0.087	1p	0.005
2510.0	16339308.	270.13	0.00000	1180079.	0.	2.14	0.00	782.33	0.00	1180079.	0.087	1p	0.005
2530.0	16474762.	270.17	0.00000	1180249.	0.	2.14	0.00	782.44	0.00	1180249.	0.087	1p	0.005

SAMPLE 2 INPUT FILE

Sample 2 for Simulator GWELL
 - Option 2 used -

2.0000E+06
 12.40E+06
 0.100E+06
 0.00
 2530.000
 0.000
 2800.000
 1000.000
 6.0480E+05
 20

300.0	0.1102	4.6E-5	25.0	90.0
30.0	0.1102	4.6E-5	15.0	88.0
30.0	0.1102	4.6E-5	15.0	86.0
30.0	0.1102	4.6E-5	15.0	84.0
30.0	0.1102	4.6E-5	15.0	82.0
30.0	0.1102	4.6E-5	15.0	80.0
30.0	0.1102	4.6E-5	15.0	78.0
30.0	0.1102	4.6E-5	15.0	76.0
30.0	0.1102	4.6E-5	15.0	74.0
30.0	0.1102	4.6E-5	15.0	72.0
30.0	0.1102	4.6E-5	15.0	70.0
30.0	0.1102	4.6E-5	15.0	68.0
30.0	0.1102	4.6E-5	15.0	66.0
30.0	0.1102	4.6E-5	15.0	64.0
30.0	0.1102	4.6E-5	15.0	62.0
30.0	0.1102	4.6E-5	15.0	60.0
150.0	0.1102	4.6E-5	25.0	60.0
10.0	0.1102	4.6E-5	10.0	60.0
1600.0	0.0873	1.5E-5	25.0	60.0
20.0	0.0873	1.5E-5	20.0	60.0

4

0.0	25.00
1000.0	260.00
2000.0	310.00
2500.0	330.00

3

1110.0	10.00E+06	1700.0E+03	5.0E-13	0.10
2010.0	13.50E+06	250.0E+03	8.00E-13	0.02
2530.0	15.35E+06	300.0	10.0E-13	0.010

SAMPLE 2 GWELL.LOG FILE

Iteration no : 0
 It no 0- Single water to two phase flow at 2110.00 m depth
 It no 0- Change of phase at a feedzone at 2010.0 m depth.
 X before= 0.01635 X after= 0.00000
 Slow convergence at 1610.0 m depth when Q= 30.49 kg/s

SAMPLE 2 GWELL.LOG FILE (cont)

```

New node added at 1622.0 m depth
Slow convergence at 1610.0 m depth when Q=      30.49 kg/s
New node added at 1616.0 m depth
It no 0- Single water to two phase flow at 1610.00 m depth
           Iteration no : 1
It no 1- Single water to two phase flow at 2110.00 m depth
It no 1- Change of phase at a feedzone at 2010.0 m depth.
X before= 0.01645 X after= 0.00000
It no 1- Single water to two phase flow at 1610.00 m depth
           Iteration no : 2
It no 2- Single water to two phase flow at 2110.00 m depth
It no 2- Change of phase at a feedzone at 2010.0 m depth.
X before= 0.01654 X after= 0.00000
It no 2- Single water to two phase flow at 1610.00 m depth
           Iteration no : 3
It no 3- Single water to two phase flow at 2110.00 m depth
It no 3- Change of phase at a feedzone at 2010.0 m depth.
X before= 0.01664 X after= 0.00000
It no 3- Single water to two phase flow at 1610.00 m depth
           Iteration no : 4
It no 4- Single water to two phase flow at 2110.00 m depth
It no 4- Change of phase at a feedzone at 2010.0 m depth.
X before= 0.01674 X after= 0.00000
It no 4- Single water to two phase flow at 1610.00 m depth
           Iteration no : 5
It no 5- Single water to two phase flow at 2110.00 m depth
It no 5- Change of phase at a feedzone at 2010.0 m depth.
X before= 0.01684 X after= 0.00000
It no 5- Single water to two phase flow at 1610.00 m depth
    
```

SAMPLE 2 GWELL.ITER FILE

P required (bars)	Max Error (bars)	Step size (bars)	Pbott Max (bars)	Pbott min (bars)	
20.0000	1.0000	0.0200	153.4800	20.0000	

It no	P bottom (bars)	P top (bars)	Difference (bars)	Q top (kg/s)	H top (kJ/kg)
0	124.0000	21.1408	1.1408	44.170	1255.522
1	123.9800	21.1089	1.1089	44.195	1255.596
2	123.9600	21.0741	1.0741	44.221	1255.681
3	123.9400	21.0392	1.0392	44.246	1255.768
4	123.9200	21.0042	1.0042	44.272	1255.852
5	123.9000	20.9691	0.9691	44.298	1255.938

SAMPLE 2 OUTPUT FILE

GWELL - MODEL RESULTS

Sample 2 for Simulator GWELL
- Option 2 used -

```

Wellhead pressure ( bar abs. ) :    20.97
Wellhead temperature ( C )      :    206.35
Wellhead dryness                 :     0.248
Wellhead enthalpy ( kJ/kg )     :   1255.94
Wellhead total flow ( kg/s )    :     44.30
Wellhead CO2                    :     0.0395
    
```

Feedzone no:	Depth (m)	Flow (kg/s)	Enthalpy (kJ/kg)	Res.Pres (Bar)	Satur.	Prod. Ind. (m3)	XC02
1	1110.0	13.7107	1700.0	100.000	0.90	0.500000E-12	0.1000
2	2010.0	7.1739	250.0	135.000	0.00	0.800000E-12	0.0200
3	2530.0	23.4132	1332.4	153.500	0.00	0.100000E-11	0.0100

Depth (m)	Press (Pa)	Temp (C)	Dryness	Hw (J/kg)	Hs (J/kg)	Vw (m/s)	Vs (m/s)	Dw (kg/m3)	Ds (kg/m3)	H_t (J/kg)	Rad (m)	Reg	XC02
0.0	2096907.	206.35	0.24812	880267.	2394349.	20.96	24.18	857.21	12.52	1255938.	0.110	Sl	0.039
25.0	2130424.	207.09	0.24684	883616.	2392974.	20.57	23.71	856.32	12.72	1256192.	0.110	Bu	0.039
50.0	2163837.	207.82	0.24559	886913.	2391597.	20.20	23.25	855.44	12.92	1256446.	0.110	Bu	0.039
75.0	2197160.	208.53	0.24435	890162.	2390220.	19.85	22.80	854.58	13.12	1256699.	0.110	Bu	0.039
100.0	2230403.	209.24	0.24312	893365.	2388840.	19.50	22.37	853.72	13.32	1256952.	0.110	Bu	0.039
125.0	2263578.	209.94	0.24192	896524.	2387458.	19.17	21.96	852.88	13.52	1257204.	0.110	Bu	0.039
150.0	2296696.	210.62	0.24072	899641.	2386074.	18.84	21.56	852.04	13.72	1257456.	0.110	Bu	0.039
175.0	2329767.	211.30	0.23954	902719.	2384688.	18.53	21.17	851.22	13.91	1257708.	0.110	Bu	0.039
200.0	2362800.	211.97	0.23837	905759.	2383298.	18.22	20.80	850.40	14.11	1257960.	0.110	Bu	0.039
225.0	2395806.	212.63	0.23721	908763.	2381905.	17.93	20.43	849.59	14.31	1258211.	0.110	Bu	0.039
250.0	2428793.	213.28	0.23607	911733.	2380508.	17.64	20.08	848.78	14.51	1258462.	0.110	Bu	0.039

275.0	2461770.	213.93	0.23493	914671.	2379108.	17.36	19.74	847.99	14.71	1258712.	0.110	Bu	0.039
300.0	2494745.	214.57	0.23381	917577.	2377703.	17.08	19.40	847.19	14.91	1258963.	0.110	Bu	0.039
315.0	2514533.	214.95	0.23313	919307.	2376858.	16.92	19.21	846.72	15.03	1259113.	0.110	Bu	0.039
330.0	2534319.	215.32	0.23247	921026.	2376012.	16.77	19.02	846.25	15.14	1259263.	0.110	Bu	0.039
345.0	2554110.	215.70	0.23180	922734.	2375163.	16.61	18.83	845.79	15.26	1259413.	0.110	Bu	0.039
360.0	2573891.	216.07	0.23114	924432.	2374314.	16.46	18.64	845.32	15.38	1259562.	0.110	Bu	0.039
375.0	2593681.	216.44	0.23049	926119.	2373463.	16.31	18.46	844.86	15.50	1259712.	0.110	Bu	0.039
390.0	2613450.	216.80	0.22983	927795.	2372611.	16.16	18.28	844.40	15.62	1259861.	0.110	Bu	0.039
405.0	2633231.	217.17	0.22918	929462.	2371757.	16.01	18.10	843.94	15.74	1260010.	0.110	Bu	0.039
420.0	2652981.	217.53	0.22854	931116.	2370903.	15.87	17.93	843.49	15.86	1260158.	0.110	Bu	0.039
435.0	2672746.	217.89	0.22789	932761.	2370046.	15.73	17.76	843.04	15.98	1260306.	0.110	Bu	0.039
450.0	2692469.	218.25	0.22725	934394.	2369190.	15.59	17.59	842.59	16.10	1260453.	0.110	Bu	0.039
465.0	2712208.	218.60	0.22661	936018.	2368331.	15.45	17.42	842.14	16.22	1260601.	0.110	Bu	0.039
480.0	2731894.	218.95	0.22598	937629.	2367473.	15.32	17.26	841.69	16.34	1260747.	0.110	Bu	0.039
495.0	2751598.	219.30	0.22535	939231.	2366613.	15.18	17.10	841.25	16.46	1260893.	0.110	Bu	0.039
510.0	2771237.	219.65	0.22472	940820.	2365754.	15.05	16.94	840.81	16.58	1261038.	0.110	Bu	0.039
525.0	2790896.	219.99	0.22410	942401.	2364892.	14.92	16.79	840.37	16.70	1261183.	0.110	Bu	0.039
540.0	2810477.	220.34	0.22348	943967.	2364032.	14.80	16.64	839.94	16.82	1261326.	0.110	Bu	0.039
555.0	2830080.	220.68	0.22287	945526.	2363170.	14.67	16.49	839.50	16.94	1261470.	0.110	Bu	0.039
570.0	2849590.	221.01	0.22225	947068.	2362310.	14.55	16.34	839.07	17.05	1261612.	0.110	Bu	0.039
585.0	2869125.	221.35	0.22164	948605.	2361447.	14.43	16.20	838.65	17.17	1261754.	0.110	Bu	0.039
600.0	2888552.	221.68	0.22104	950125.	2360587.	14.31	16.05	838.22	17.29	1261894.	0.110	Bu	0.039
615.0	2908005.	222.01	0.22044	951638.	2359724.	14.19	15.91	837.80	17.41	1262034.	0.110	Bu	0.039
630.0	2927337.	222.33	0.21984	953134.	2358865.	14.07	15.78	837.38	17.53	1262172.	0.110	Bu	0.039
645.0	2946695.	222.66	0.21925	954624.	2358004.	13.96	15.64	836.96	17.65	1262310.	0.110	Bu	0.039
660.0	2965916.	222.97	0.21866	956095.	2357146.	13.85	15.51	836.55	17.76	1262446.	0.110	Bu	0.039
675.0	2985164.	223.29	0.21807	957561.	2356286.	13.74	15.38	836.14	17.88	1262582.	0.110	Bu	0.039
690.0	3004260.	223.61	0.21749	959008.	2355431.	13.63	15.25	835.73	18.00	1262716.	0.110	Bu	0.039
705.0	3023383.	223.92	0.21691	960450.	2354573.	13.52	15.12	835.33	18.11	1262850.	0.110	Bu	0.039
720.0	3042338.	224.23	0.21634	961871.	2353720.	13.42	15.00	834.93	18.23	1262981.	0.110	Bu	0.039
735.0	3061321.	224.54	0.21577	963288.	2352865.	13.32	14.87	834.53	18.35	1263113.	0.110	Bu	0.039
750.0	3080118.	224.84	0.21520	964683.	2352016.	13.22	14.75	834.13	18.46	1263242.	0.110	Bu	0.039
775.0	3111510.	225.34	0.21427	966998.	2350596.	13.05	14.56	833.48	18.65	1263456.	0.110	Bu	0.039
800.0	3142984.	225.84	0.21333	969301.	2349168.	12.89	14.36	832.83	18.85	1263671.	0.110	Bu	0.039
825.0	3174544.	226.33	0.21240	971591.	2347733.	12.73	14.18	832.18	19.04	1263886.	0.110	Bu	0.039
850.0	3206194.	226.83	0.21147	973869.	2346291.	12.57	13.99	831.53	19.24	1264100.	0.110	Bu	0.039
875.0	3237940.	227.32	0.21055	976135.	2344841.	12.42	13.81	830.88	19.43	1264315.	0.110	Bu	0.039
900.0	3269785.	227.80	0.20963	978391.	2343383.	12.26	13.63	830.24	19.63	1264529.	0.110	Bu	0.039
910.0	3282552.	228.00	0.20926	979290.	2342798.	12.20	13.56	829.98	19.71	1264615.	0.110	Bu	0.039
935.0	3344158.	228.92	0.20734	983550.	2339636.	19.17	21.04	828.76	20.09	1264714.	0.087	Bu	0.039
960.0	3388350.	229.57	0.20604	986584.	2337514.	18.85	20.67	827.89	20.36	1264933.	0.087	Bu	0.039
985.0	3432521.	230.22	0.20476	989584.	2335386.	18.54	20.31	827.03	20.64	1265151.	0.087	Bu	0.039
1010.0	3476683.	230.86	0.20349	992552.	2333252.	18.23	19.96	826.17	20.91	1265370.	0.087	Bu	0.039
1035.0	3520849.	231.49	0.20223	995489.	2331111.	17.94	19.62	825.32	21.19	1265588.	0.087	Bu	0.039

1060.0	3565029.	232.11	0.20097	998396.	2328963.	17.65	19.28	824.48	21.46	1265806.	0.087	Bu	0.039
1085.0	3609235.	232.73	0.19973	1001276.	2326808.	17.37	18.96	823.64	21.74	1266023.	0.087	Bu	0.039
1110.0	3653477.	233.34	0.19849	1004128.	2324644.	17.09	18.65	822.81	22.01	1266241.	0.087	Bu	0.039
1110.0	3653477.	233.44	0.05079	1004584.	2328212.	2.56	6.95	822.69	21.99	1071805.	0.087	Bu	0.012
1135.0	3817056.	235.14	0.04626	1012406.	2301115.	2.55	6.10	820.37	23.17	1072018.	0.087	Bu	0.012
1160.0	3975314.	236.66	0.04212	1019391.	2273857.	2.54	5.37	818.28	24.35	1072231.	0.087	Bu	0.012
1185.0	4128346.	238.01	0.03834	1025627.	2246620.	2.52	4.76	816.39	25.51	1072443.	0.087	Bu	0.012
1210.0	4276423.	239.23	0.03489	1031200.	2219544.	2.50	4.23	814.69	26.65	1072656.	0.087	Bu	0.012
1235.0	4419944.	240.33	0.03171	1036190.	2192725.	2.47	3.79	813.15	27.78	1072868.	0.087	Bu	0.012
1260.0	4559366.	241.31	0.02880	1040670.	2166227.	2.44	3.41	811.76	28.90	1073081.	0.087	Bu	0.012
1285.0	4695170.	242.21	0.02610	1044705.	2140089.	2.40	3.09	810.49	30.01	1073293.	0.087	Bu	0.012
1310.0	4827834.	243.02	0.02360	1048353.	2114328.	2.35	2.81	809.34	31.10	1073506.	0.087	Bu	0.012
1335.0	4961014.	243.77	0.02121	1051737.	2088303.	2.27	2.65	808.25	32.22	1073718.	0.087	Bu	0.012
1360.0	5096514.	244.49	0.01889	1054909.	2061723.	2.20	2.46	807.23	33.37	1073931.	0.087	Bu	0.012
1385.0	5232641.	245.16	0.01668	1057841.	2035010.	2.13	2.29	806.27	34.55	1074143.	0.087	Bu	0.012
1410.0	5369526.	245.78	0.01457	1060550.	2008211.	2.07	2.14	805.37	35.74	1074356.	0.087	Bu	0.012
1435.0	5507286.	246.36	0.01254	1063052.	1981375.	2.00	2.01	804.53	36.96	1074568.	0.087	Bu	0.012
1460.0	5646021.	246.90	0.01059	1065360.	1954549.	1.94	1.89	803.74	38.20	1074781.	0.087	Bu	0.012
1485.0	5785815.	247.40	0.00872	1067488.	1927778.	1.88	1.78	803.00	39.46	1074993.	0.087	Bu	0.012
1510.0	5926736.	247.87	0.00692	1069449.	1901109.	1.82	1.68	802.32	40.74	1075206.	0.087	Bu	0.012
1535.0	6068835.	248.31	0.00518	1071253.	1874582.	1.76	1.59	801.67	42.04	1075418.	0.087	Bu	0.012
1560.0	6212148.	248.72	0.00351	1072912.	1848241.	1.71	1.51	801.06	43.37	1075631.	0.087	Bu	0.012
1585.0	6356696.	249.11	0.00188	1074434.	1822123.	1.65	1.44	800.50	44.72	1075843.	0.087	Bu	0.012
1610.0	6514856.	249.49	0.00018	1075927.	1794009.	1.60	1.60	799.93	46.21	1076056.	0.087	Bu	0.012
1635.0	6686897.	249.57	0.00000	1076139.	0.	1.59	0.00	802.98	0.00	1076139.	0.087	1p	0.012
1660.0	6859280.	249.62	0.00000	1076351.	0.	1.59	0.00	803.11	0.00	1076351.	0.087	1p	0.012
1685.0	7031690.	249.66	0.00000	1076564.	0.	1.59	0.00	803.24	0.00	1076564.	0.087	1p	0.012
1710.0	7204127.	249.71	0.00000	1076776.	0.	1.59	0.00	803.36	0.00	1076776.	0.087	1p	0.012
1735.0	7376591.	249.75	0.00000	1076988.	0.	1.59	0.00	803.49	0.00	1076988.	0.087	1p	0.012
1760.0	7549081.	249.80	0.00000	1077201.	0.	1.59	0.00	803.62	0.00	1077201.	0.087	1p	0.012
1785.0	7721598.	249.84	0.00000	1077413.	0.	1.59	0.00	803.75	0.00	1077413.	0.087	1p	0.012
1810.0	7894142.	249.89	0.00000	1077625.	0.	1.59	0.00	803.87	0.00	1077625.	0.087	1p	0.012
1835.0	8066713.	249.93	0.00000	1077838.	0.	1.59	0.00	804.00	0.00	1077838.	0.087	1p	0.012
1860.0	8239310.	249.98	0.00000	1078050.	0.	1.59	0.00	804.13	0.00	1078050.	0.087	1p	0.012
1885.0	8411934.	250.02	0.00000	1078262.	0.	1.59	0.00	804.25	0.00	1078262.	0.087	1p	0.012
1910.0	8584584.	250.07	0.00000	1078475.	0.	1.59	0.00	804.38	0.00	1078475.	0.087	1p	0.012
1935.0	8757261.	250.11	0.00000	1078687.	0.	1.59	0.00	804.51	0.00	1078687.	0.087	1p	0.012
1960.0	8929965.	250.16	0.00000	1078900.	0.	1.59	0.00	804.63	0.00	1078900.	0.087	1p	0.012
1985.0	9102695.	250.20	0.00000	1079112.	0.	1.59	0.00	804.76	0.00	1079112.	0.087	1p	0.012
2010.0	9275451.	250.25	0.00000	1079324.	0.	1.59	0.00	804.88	0.00	1079324.	0.087	1p	0.012
2010.0	9275451.	295.29	0.01684	1314624.	2431317.	1.64	1.63	721.78	54.30	1333426.	0.087	Bu	0.010
2035.0	9404016.	296.00	0.01382	1318377.	2422705.	1.59	1.54	720.36	55.23	1333639.	0.087	Bu	0.010
2060.0	9533233.	296.70	0.01081	1322047.	2413864.	1.54	1.46	718.96	56.17	1333851.	0.087	Bu	0.010
2085.0	9663186.	297.38	0.00781	1325634.	2404781.	1.50	1.38	717.59	57.11	1334063.	0.087	Bu	0.010

2110.0	9801154.	298.07	0.00465	1329322.	2394901.	1.37	1.37	716.17	58.13	1334276.	0.087	Bu	0.010
2135.0	9954724.	298.51	0.00000	1329532.	2402845.	1.36	1.36	718.65	57.20	1329532.	0.087	1p	0.010
2160.0	10108580.	298.58	0.00000	1329745.	2392872.	1.36	1.36	718.83	58.22	1329745.	0.087	1p	0.010
2185.0	10262472.	298.65	0.00000	1329957.	0.	1.36	0.00	719.01	0.00	1329957.	0.087	1p	0.010
2210.0	10416403.	298.71	0.00000	1330169.	0.	1.36	0.00	719.19	0.00	1330169.	0.087	1p	0.010
2235.0	10570371.	298.78	0.00000	1330381.	0.	1.36	0.00	719.36	0.00	1330381.	0.087	1p	0.010
2260.0	10724376.	298.85	0.00000	1330593.	0.	1.36	0.00	719.54	0.00	1330593.	0.087	1p	0.010
2285.0	10878419.	298.91	0.00000	1330805.	0.	1.36	0.00	719.72	0.00	1330805.	0.087	1p	0.010
2310.0	11032499.	298.98	0.00000	1331017.	0.	1.36	0.00	719.90	0.00	1331017.	0.087	1p	0.010
2335.0	11186616.	299.05	0.00000	1331230.	0.	1.36	0.00	720.07	0.00	1331230.	0.087	1p	0.010
2360.0	11340770.	299.11	0.00000	1331442.	0.	1.36	0.00	720.25	0.00	1331442.	0.087	1p	0.010
2385.0	11494962.	299.18	0.00000	1331654.	0.	1.36	0.00	720.42	0.00	1331654.	0.087	1p	0.010
2410.0	11649190.	299.25	0.00000	1331866.	0.	1.36	0.00	720.60	0.00	1331866.	0.087	1p	0.010
2435.0	11803456.	299.31	0.00000	1332078.	0.	1.36	0.00	720.77	0.00	1332078.	0.087	1p	0.010
2460.0	11957758.	299.38	0.00000	1332290.	0.	1.36	0.00	720.95	0.00	1332290.	0.087	1p	0.010
2485.0	12112097.	299.45	0.00000	1332503.	0.	1.36	0.00	721.12	0.00	1332503.	0.087	1p	0.010
2510.0	12266473.	299.51	0.00000	1332715.	0.	1.36	0.00	721.30	0.00	1332715.	0.087	1p	0.010
2530.0	12390000.	299.57	0.00000	1332884.	0.	1.36	24.11	721.44	0.00	1332884.	0.087	1p	0.010
2530.0	12390000.	299.57	0.00000	1332884.	0.	1.36	24.11	721.44	0.00	1332884.	0.087	1p	0.010

APPENDIX B
(SAMPLE RUNS FOR GWNACL)

SAMPLE 1 INPUT FILE

```

Sample 1 for Simulator GWNACL
- Option 1 used -
- The well is producing two-phase fluid at the wellhead -
2.0000E+06
1.4000E+06
100.0000
0.008
2530.000
0.000
2800.000
1000.000
6.0480E+05
20
  300.0  0.1102  4.6E-5    25.0   90.0
    30.0  0.1102  4.6E-5    15.0   88.0
    30.0  0.1102  4.6E-5    15.0   86.0
    30.0  0.1102  4.6E-5    15.0   84.0
    30.0  0.1102  4.6E-5    15.0   82.0
    30.0  0.1102  4.6E-5    15.0   80.0
    30.0  0.1102  4.6E-5    15.0   78.0
    30.0  0.1102  4.6E-5    15.0   76.0
    30.0  0.1102  4.6E-5    15.0   74.0
    30.0  0.1102  4.6E-5    15.0   72.0
    30.0  0.1102  4.6E-5    15.0   70.0
    30.0  0.1102  4.6E-5    15.0   68.0
    30.0  0.1102  4.6E-5    15.0   66.0
    30.0  0.1102  4.6E-5    15.0   64.0
    30.0  0.1102  4.6E-5    15.0   62.0
    30.0  0.1102  4.6E-5    15.0   60.0
   150.0  0.1102  4.6E-5    25.0   60.0
    10.0  0.1102  4.6E-5    10.0   60.0
  1600.0  0.0873  1.5E-5    25.0   60.0
    20.0  0.0873  1.5E-5    20.0   60.0
4
  0.0    25.00
 1000.0  260.00
 2000.0  310.00
 2500.0  330.00
3
 1110.0  20.00    1.7000E+06  0.0001
 1810.0  40.00    1.2000E+06  0.0070

```

SAMPLE 1 GWNACL.LOG FILE

```

Two phase to water phase
Pressure      X2      Depth
0.888494E+07 -0.00088472  1185.0
Change of phase at a feedzone at 1810.0 m depth.
X before= 0.00000 X after= 0.00059
Two phase to water phase
Pressure      X2      Depth
0.131155E+08 -0.00338873  1835.0

```

SAMPLE 1 OUTPUT FILE

GWNACL - MODEL RESULTS

Sample 1 for Simulator GWNACL

- Option 1 used -

- The well is producing two-phase fluid at the wellhead -

```
Wellhead pressure ( bar abs. ) :    20.00
Wellhead temperature ( C )      :    212.70
Wellhead dryness                 :     0.263
Wellhead enthalpy ( kJ/kg )     :    1400.00
Wellhead total flow ( kg/s )    :     100.00
Wellhead NaCl                   :     0.0080
```

Feedzone no:	Depth (m)	Flow (kg/s)	Enthalpy (kJ/kg)	XNaCl
1	1110.0	20.0000	1700.0	0.0001
2	1810.0	40.0000	1200.0	0.0070
3	2530.0	40.0000	1498.9	0.0129

Depth (m)	Press (Pa)	Temp (C)	Dryness	Hw (J/kg)	Hs (J/kg)	Vw (m/s)	Vs (m/s)	Dw (kg/m ³)	Ds (kg/m ³)	H_t (J/kg)	Rad (m)	Reg	XNaCl
0.0	2000000.	212.70	0.26316	899939.	2800127.	63.96	71.30	840.44	10.03	1400000.	0.110	Sl	0.008
25.0	2105104.	215.30	0.25865	911800.	2801222.	60.18	66.83	836.95	10.55	1400501.	0.110	Sl	0.008
50.0	2204725.	217.68	0.25448	922664.	2802122.	56.92	63.01	833.73	11.04	1400954.	0.110	Sl	0.008
75.0	2299792.	219.87	0.25060	932715.	2802865.	54.07	59.68	830.74	11.51	1401370.	0.110	Sl	0.008
100.0	2391011.	221.91	0.24695	942091.	2803479.	51.55	56.75	827.95	11.96	1401759.	0.110	Sl	0.008
125.0	2478932.	223.82	0.24350	950897.	2803987.	49.29	54.13	825.31	12.39	1402126.	0.110	Sl	0.008
150.0	2563995.	225.62	0.24023	959213.	2804403.	47.26	51.78	822.81	12.82	1402477.	0.110	Sl	0.008
175.0	2646559.	227.32	0.23710	967105.	2804742.	45.41	49.66	820.43	13.23	1402814.	0.110	Sl	0.008
200.0	2726919.	228.94	0.23411	974627.	2805012.	43.72	47.71	818.15	13.63	1403140.	0.110	Sl	0.008
225.0	2805327.	230.48	0.23124	981821.	2805222.	42.16	45.93	815.97	14.02	1403456.	0.110	Sl	0.008
250.0	2881993.	231.96	0.22846	988724.	2805379.	40.72	44.29	813.87	14.40	1403765.	0.110	Sl	0.008
275.0	2957099.	233.38	0.22579	995366.	2805489.	39.38	42.77	811.85	14.77	1404067.	0.110	Sl	0.008

300.0	3030805.	234.74	0.22319	1001775.	2805556.	38.14	41.36	809.89	15.14	1404363.	0.110	SI	0.008
315.0	3074405.	235.54	0.22167	1005517.	2805577.	37.43	40.56	808.75	15.36	1404539.	0.110	SI	0.008
330.0	3117578.	236.32	0.22018	1009187.	2805585.	36.75	39.79	807.62	15.58	1404712.	0.110	SI	0.008
345.0	3160329.	237.08	0.21871	1012788.	2805581.	36.09	39.04	806.52	15.79	1404884.	0.110	SI	0.008
360.0	3202701.	237.83	0.21726	1016325.	2805564.	35.46	38.33	805.44	16.01	1405055.	0.110	SI	0.008
375.0	3244683.	238.56	0.21584	1019798.	2805537.	34.85	37.64	804.37	16.22	1405224.	0.110	SI	0.008
390.0	3286328.	239.29	0.21443	1023214.	2805498.	34.26	36.98	803.32	16.43	1405392.	0.110	SI	0.008
405.0	3327606.	239.99	0.21305	1026572.	2805450.	33.69	36.34	802.28	16.64	1405558.	0.110	SI	0.008
420.0	3368584.	240.69	0.21168	1029877.	2805391.	33.14	35.72	801.27	16.84	1405723.	0.110	SI	0.008
435.0	3409214.	241.37	0.21034	1033129.	2805323.	32.60	35.12	800.26	17.05	1405886.	0.110	SI	0.008
450.0	3449576.	242.05	0.20901	1036333.	2805246.	32.09	34.54	799.27	17.25	1406049.	0.110	SI	0.008
465.0	3489604.	242.71	0.20770	1039487.	2805161.	31.59	33.98	798.30	17.46	1406209.	0.110	SI	0.008
480.0	3529393.	243.36	0.20640	1042598.	2805067.	31.10	33.44	797.34	17.66	1406369.	0.110	SI	0.008
495.0	3568857.	244.00	0.20512	1045661.	2804966.	30.63	32.91	796.39	17.86	1406527.	0.110	SI	0.008
510.0	3608108.	244.64	0.20385	1048685.	2804856.	30.17	32.40	795.45	18.06	1406685.	0.110	SI	0.008
525.0	3647039.	245.26	0.20260	1051664.	2804740.	29.73	31.91	794.53	18.26	1406840.	0.110	SI	0.008
540.0	3685779.	245.87	0.20136	1054607.	2804616.	29.30	31.43	793.62	18.46	1406995.	0.110	SI	0.008
555.0	3724202.	246.48	0.20014	1057506.	2804486.	28.88	30.96	792.72	18.65	1407147.	0.110	SI	0.008
570.0	3762455.	247.07	0.19893	1060372.	2804349.	28.47	30.51	791.83	18.85	1407300.	0.110	SI	0.008
585.0	3800389.	247.66	0.19773	1063197.	2804207.	28.07	30.06	790.95	19.04	1407450.	0.110	SI	0.008
600.0	3838172.	248.24	0.19654	1065991.	2804058.	27.68	29.63	790.08	19.24	1407599.	0.110	SI	0.008
615.0	3875633.	248.81	0.19537	1068744.	2803903.	27.31	29.22	789.22	19.43	1407746.	0.110	SI	0.008
630.0	3912958.	249.38	0.19421	1071470.	2803743.	26.94	28.81	788.37	19.62	1407893.	0.110	SI	0.008
645.0	3949956.	249.93	0.19306	1074155.	2803577.	26.58	28.41	787.54	19.81	1408038.	0.110	SI	0.008
660.0	3986833.	250.48	0.19192	1076816.	2803406.	26.23	28.03	786.71	20.00	1408182.	0.110	SI	0.008
675.0	4023374.	251.02	0.19079	1079436.	2803231.	25.90	27.65	785.89	20.19	1408323.	0.110	SI	0.008
690.0	4059807.	251.56	0.18967	1082033.	2803050.	25.56	27.28	785.08	20.38	1408464.	0.110	SI	0.008
705.0	4176047.	253.24	0.18599	1090223.	2802436.	5.00	51.07	782.52	20.98	1408677.	0.110	SI	0.008
720.0	4311166.	255.16	0.18170	1099560.	2801653.	4.97	49.26	779.60	21.68	1408829.	0.110	SI	0.008
735.0	4446222.	257.03	0.17745	1108708.	2800799.	4.92	47.66	776.72	22.39	1408975.	0.110	SI	0.008
750.0	4583499.	258.88	0.17318	1117826.	2799862.	4.89	45.98	773.86	23.11	1409121.	0.110	SI	0.008
775.0	4816612.	261.94	0.16601	1132921.	2798122.	4.84	43.29	769.11	24.34	1409361.	0.110	SI	0.008
800.0	5055065.	264.95	0.15878	1147893.	2796161.	4.80	40.71	764.38	25.61	1409598.	0.110	SI	0.008
825.0	5298674.	267.91	0.15147	1162740.	2793984.	4.77	38.23	759.69	26.92	1409831.	0.110	SI	0.008
850.0	5547091.	270.83	0.14411	1177450.	2791596.	4.74	35.82	755.03	28.27	1410062.	0.110	SI	0.008
875.0	5799790.	273.70	0.13669	1192003.	2789007.	4.72	33.49	750.41	29.66	1410290.	0.110	SI	0.008
900.0	6056050.	276.51	0.12922	1206372.	2786229.	4.70	31.22	745.85	31.08	1410516.	0.110	SI	0.008
910.0	6159382.	277.62	0.12622	1212062.	2785067.	4.70	30.32	744.05	31.66	1410606.	0.110	SI	0.008
935.0	6405109.	280.20	0.11907	1225366.	2782215.	7.40	45.89	739.82	33.04	1410737.	0.087	SI	0.008
960.0	6702984.	283.23	0.11050	1241088.	2778598.	7.40	41.98	734.83	34.74	1410977.	0.087	SI	0.008
985.0	6998679.	286.13	0.10202	1256290.	2774845.	7.40	38.21	730.00	36.44	1411212.	0.087	SI	0.008
1010.0	7290448.	288.91	0.09367	1270924.	2770997.	7.42	34.60	725.35	38.15	1411442.	0.087	SI	0.008
1035.0	7576529.	291.55	0.08550	1284943.	2767092.	7.44	31.18	720.90	39.85	1411669.	0.087	SI	0.008

1060.0	7855282.	294.05	0.07754	1298310.	2763169.	7.46	27.95	716.65	41.52	1411892.	0.087	sl	0.008
1085.0	8125298.	296.41	0.06982	1311000.	2759266.	7.47	24.96	712.63	43.17	1412113.	0.087	sl	0.008
1110.0	8385500.	298.63	0.06236	1323001.	2755413.	7.49	22.20	708.83	44.77	1412331.	0.087	sl	0.008
1110.0	8385500.	298.70	0.01425	1319954.	2755845.	5.44	7.14	711.03	44.75	1340414.	0.087	sl	0.010
1135.0	8559767.	300.15	0.00897	1327839.	2753222.	5.24	6.08	708.52	45.84	1340628.	0.087	Bu	0.010
1160.0	8725913.	301.52	0.00394	1335271.	2750688.	4.98	5.17	706.16	46.89	1340841.	0.087	Bu	0.010
1185.0	8889907.	302.58	0.00000	1341055.	0.	4.75	0.00	703.03	0.00	1341055.	0.087	1p	0.010
1210.0	9052852.	302.62	0.00000	1341267.	0.	4.75	0.00	703.23	0.00	1341267.	0.087	1p	0.010
1235.0	9215838.	302.66	0.00000	1341480.	0.	4.75	0.00	703.43	0.00	1341480.	0.087	1p	0.010
1260.0	9378863.	302.70	0.00000	1341692.	0.	4.75	0.00	703.64	0.00	1341692.	0.087	1p	0.010
1285.0	9541927.	302.74	0.00000	1341905.	0.	4.75	0.00	703.84	0.00	1341905.	0.087	1p	0.010
1310.0	9705032.	302.78	0.00000	1342117.	0.	4.75	0.00	704.05	0.00	1342117.	0.087	1p	0.010
1335.0	9868176.	302.82	0.00000	1342329.	0.	4.74	0.00	704.25	0.00	1342329.	0.087	1p	0.010
1360.0	10031359.	302.86	0.00000	1342542.	0.	4.74	0.00	704.46	0.00	1342542.	0.087	1p	0.010
1385.0	10194583.	302.90	0.00000	1342754.	0.	4.74	0.00	704.66	0.00	1342754.	0.087	1p	0.010
1410.0	10357845.	302.94	0.00000	1342967.	0.	4.74	0.00	704.87	0.00	1342967.	0.087	1p	0.010
1435.0	10521148.	302.98	0.00000	1343179.	0.	4.74	0.00	705.07	0.00	1343179.	0.087	1p	0.010
1460.0	10684490.	303.01	0.00000	1343392.	0.	4.74	0.00	705.28	0.00	1343392.	0.087	1p	0.010
1485.0	10847872.	303.05	0.00000	1343604.	0.	4.74	0.00	705.48	0.00	1343604.	0.087	1p	0.010
1510.0	11011294.	303.09	0.00000	1343816.	0.	4.73	0.00	705.69	0.00	1343816.	0.087	1p	0.010
1535.0	11174755.	303.13	0.00000	1344029.	0.	4.73	0.00	705.89	0.00	1344029.	0.087	1p	0.010
1560.0	11338256.	303.17	0.00000	1344241.	0.	4.73	0.00	706.10	0.00	1344241.	0.087	1p	0.010
1585.0	11501797.	303.21	0.00000	1344454.	0.	4.73	0.00	706.30	0.00	1344454.	0.087	1p	0.010
1610.0	11665377.	303.25	0.00000	1344666.	0.	4.73	0.00	706.51	0.00	1344666.	0.087	1p	0.010
1635.0	11828997.	303.29	0.00000	1344878.	0.	4.73	0.00	706.71	0.00	1344878.	0.087	1p	0.010
1660.0	11992657.	303.33	0.00000	1345091.	0.	4.73	0.00	706.92	0.00	1345091.	0.087	1p	0.010
1685.0	12156357.	303.37	0.00000	1345303.	0.	4.73	0.00	707.12	0.00	1345303.	0.087	1p	0.010
1710.0	12320096.	303.41	0.00000	1345516.	0.	4.72	0.00	707.33	0.00	1345516.	0.087	1p	0.010
1735.0	12483875.	303.45	0.00000	1345728.	0.	4.72	0.00	707.53	0.00	1345728.	0.087	1p	0.010
1760.0	12647693.	303.49	0.00000	1345941.	0.	4.72	0.00	707.74	0.00	1345941.	0.087	1p	0.010
1785.0	12811551.	303.53	0.00000	1346153.	0.	4.72	0.00	707.94	0.00	1346153.	0.087	1p	0.010
1810.0	12975449.	303.57	0.00000	1346365.	0.	4.72	0.00	708.15	0.00	1346365.	0.087	1p	0.010
1810.0	12975449.	331.30	0.00059	1492034.	2678709.	2.54	2.49	659.70	77.35	1492731.	0.087	Bu	0.013
1835.0	13119065.	331.45	0.00000	1492943.	0.	2.54	0.00	657.70	0.00	1492943.	0.087	1p	0.013
1860.0	13262489.	331.49	0.00000	1493156.	0.	2.54	0.00	657.90	0.00	1493156.	0.087	1p	0.013
1885.0	13405953.	331.53	0.00000	1493368.	0.	2.54	0.00	658.09	0.00	1493368.	0.087	1p	0.013
1910.0	13549456.	331.57	0.00000	1493581.	0.	2.54	0.00	658.28	0.00	1493581.	0.087	1p	0.013
1935.0	13693000.	331.60	0.00000	1493793.	0.	2.54	0.00	658.47	0.00	1493793.	0.087	1p	0.013
1960.0	13836583.	331.64	0.00000	1494006.	0.	2.54	0.00	658.66	0.00	1494006.	0.087	1p	0.013
1985.0	13980207.	331.68	0.00000	1494219.	0.	2.54	0.00	658.86	0.00	1494219.	0.087	1p	0.013
2010.0	14123870.	331.71	0.00000	1494431.	0.	2.53	0.00	659.05	0.00	1494431.	0.087	1p	0.013
2035.0	14267573.	331.75	0.00000	1494644.	0.	2.53	0.00	659.24	0.00	1494644.	0.087	1p	0.013
2060.0	14411316.	331.79	0.00000	1494856.	0.	2.53	0.00	659.43	0.00	1494856.	0.087	1p	0.013
2085.0	14555098.	331.83	0.00000	1495069.	0.	2.53	0.00	659.63	0.00	1495069.	0.087	1p	0.013

2110.0	14698921.	331.86	0.00000	1495281.	0.	2.53	0.00	659.82	0.00	1495281.	0.087	1p	0.013
2135.0	14842783.	331.90	0.00000	1495494.	0.	2.53	0.00	660.01	0.00	1495494.	0.087	1p	0.013
2160.0	14986685.	331.94	0.00000	1495706.	0.	2.53	0.00	660.20	0.00	1495706.	0.087	1p	0.013
2185.0	15130627.	331.98	0.00000	1495919.	0.	2.53	0.00	660.40	0.00	1495919.	0.087	1p	0.013
2210.0	15274609.	332.01	0.00000	1496131.	0.	2.53	0.00	660.59	0.00	1496131.	0.087	1p	0.013
2235.0	15418631.	332.05	0.00000	1496344.	0.	2.53	0.00	660.78	0.00	1496344.	0.087	1p	0.013
2260.0	15562693.	332.09	0.00000	1496556.	0.	2.53	0.00	660.97	0.00	1496556.	0.087	1p	0.013
2285.0	15706794.	332.13	0.00000	1496769.	0.	2.53	0.00	661.17	0.00	1496769.	0.087	1p	0.013
2310.0	15850936.	332.16	0.00000	1496981.	0.	2.53	0.00	661.36	0.00	1496981.	0.087	1p	0.013
2335.0	15995117.	332.20	0.00000	1497194.	0.	2.53	0.00	661.55	0.00	1497194.	0.087	1p	0.013
2360.0	16139339.	332.24	0.00000	1497406.	0.	2.52	0.00	661.75	0.00	1497406.	0.087	1p	0.013
2385.0	16283600.	332.27	0.00000	1497619.	0.	2.52	0.00	661.94	0.00	1497619.	0.087	1p	0.013
2410.0	16427901.	332.31	0.00000	1497831.	0.	2.52	0.00	662.13	0.00	1497831.	0.087	1p	0.013
2435.0	16572242.	332.35	0.00000	1498044.	0.	2.52	0.00	662.32	0.00	1498044.	0.087	1p	0.013
2460.0	16716623.	332.39	0.00000	1498256.	0.	2.52	0.00	662.52	0.00	1498256.	0.087	1p	0.013
2485.0	16861044.	332.42	0.00000	1498469.	0.	2.52	0.00	662.71	0.00	1498469.	0.087	1p	0.013
2510.0	17005505.	332.46	0.00000	1498681.	0.	2.52	0.00	662.90	0.00	1498681.	0.087	1p	0.013
2530.0	17121102.	332.49	0.00000	1498851.	0.	2.52	0.00	663.06	0.00	1498851.	0.087	1p	0.013

SAMPLE 2 INPUT FILE

Sample 2 for Simulator GWNACL
- Option 2 used -

1.5000E+06
11.60E+06
0.100E+06
0.00
2530.000
0.000
2800.000
1000.000
6.0480E+05

20
300.0 0.1102 4.6E-5 25.0 90.0
30.0 0.1102 4.6E-5 15.0 88.0
30.0 0.1102 4.6E-5 15.0 86.0
30.0 0.1102 4.6E-5 15.0 84.0
30.0 0.1102 4.6E-5 15.0 82.0
30.0 0.1102 4.6E-5 15.0 80.0
30.0 0.1102 4.6E-5 15.0 78.0
30.0 0.1102 4.6E-5 15.0 76.0
30.0 0.1102 4.6E-5 15.0 74.0
30.0 0.1102 4.6E-5 15.0 72.0
30.0 0.1102 4.6E-5 15.0 70.0
30.0 0.1102 4.6E-5 15.0 68.0
30.0 0.1102 4.6E-5 15.0 66.0
30.0 0.1102 4.6E-5 15.0 64.0
30.0 0.1102 4.6E-5 15.0 62.0
30.0 0.1102 4.6E-5 15.0 60.0
150.0 0.1102 4.6E-5 25.0 60.0
10.0 0.1102 4.6E-5 10.0 60.0
1600.0 0.0873 1.5E-5 25.0 60.0
20.0 0.0873 1.5E-5 20.0 60.0

4
0.0 25.00
1000.0 260.00
2000.0 310.00
2500.0 330.00

3
1010.0 2.00E+06 1700.0E+03 5.0E-13 0.002
1810.0 11.50E+06 1500.0E+03 8.0E-13 0.006
2530.0 14.35E+06 310.0 12.0E-13 0.010

SAMPLE 2 GWNACL.LOG FILE

```

Iteration no : 0
It no 0- Single water to two phase flow at 2210.00 m depth
Slow convergence at 1510.0 m depth when Q= 48.79 kg/s
New node added at 1522.0 m depth
Iteration no : 1
It no 1- Single water to two phase flow at 2210.00 m depth
Slow convergence at 1510.0 m depth when Q= 48.83 kg/s
New node added at 1522.0 m depth
Iteration no : 2
It no 2- Single water to two phase flow at 2210.00 m depth
Slow convergence at 1510.0 m depth when Q= 48.86 kg/s
New node added at 1522.0 m depth

```

SAMPLE 2 GWNACL.ITER FILE

	P required (bars)	Max Error (bars)	Step size (bars)	Pbott Max (bars)	Pbott min (bars)
	15.0000	1.0000	0.0200	143.4800	15.0000

It no	P bottom (bars)	P top (bars)	Difference (bars)	Q top (kg/s)	H top (kJ/kg)
0	116.0000	16.1018	1.1018	47.962	1418.676
1	115.9800	16.0262	1.0262	48.003	1418.667
2	115.9600	15.9509	0.9509	48.044	1418.653

SAMPLE 2 OUTPUT FILE

GWNACL - MODEL RESULTS

Sample 2 for Simulator GWNACL
- Option 2 used -

Wellhead pressure (bar abs.) : 15.95
 Wellhead temperature (C) : 201.54
 Wellhead dryness : 0.293
 Wellhead enthalpy (kJ/kg) : 1418.65
 Wellhead total flow (kg/s) : 48.04
 Wellhead NaCl : 0.0081

Feedzone no:	Depth (m)	Flow (kg/s)	Enthalpy (kJ/kg)	Res.Pres (Bar)	Satur.	Prod. Ind. (m3)	XNaCl
1	1010.0	-0.8192	1428.6	20.000	0.94	0.500000E-12	0.0020
2	1810.0	23.7298	1500.0	115.000	0.27	0.800000E-12	0.0060
3	2530.0	25.1336	1381.3	143.500	0.00	0.120000E-11	0.0100

82

Depth (m)	Press (Pa)	Temp (C)	Dryness	Hw (J/kg)	Hs (J/kg)	Vw (m/s)	Vs (m/s)	Dw (kg/m3)	Ds (kg/m3)	H_t (J/kg)	Rad (m)	Reg	XNaCl
0.0	1595089.	201.54	0.29269	849429.	2794239.	39.31	47.02	855.28	8.05	1418653.	0.110	Mi	0.008
25.0	1641638.	202.93	0.29045	855649.	2795077.	38.10	45.42	853.50	8.28	1418953.	0.110	Bu	0.008
50.0	1687330.	204.27	0.28829	861632.	2795855.	36.97	43.95	851.78	8.50	1419248.	0.110	Bu	0.008
75.0	1732233.	205.55	0.28620	867400.	2796579.	35.92	42.57	850.11	8.72	1419538.	0.110	Bu	0.008
100.0	1776411.	206.79	0.28419	872971.	2797253.	34.94	41.29	848.50	8.94	1419824.	0.110	Bu	0.008
125.0	1819917.	207.98	0.28223	878361.	2797882.	34.01	40.09	846.94	9.15	1420107.	0.110	Bu	0.008
150.0	1862802.	209.14	0.28033	883585.	2798470.	33.14	38.97	845.42	9.36	1420386.	0.110	Bu	0.008
175.0	1905111.	210.26	0.27848	888655.	2799019.	32.32	37.91	843.94	9.57	1420662.	0.110	Bu	0.008
200.0	1946885.	211.35	0.27669	893584.	2799534.	31.54	36.91	842.50	9.77	1420936.	0.110	Bu	0.008
225.0	1988163.	212.40	0.27494	898381.	2800015.	30.81	35.97	841.09	9.98	1421208.	0.110	Bu	0.008
250.0	2028980.	213.43	0.27323	903055.	2800466.	30.10	35.08	839.72	10.18	1421478.	0.110	Bu	0.008
275.0	2069366.	214.43	0.27156	907616.	2800889.	29.44	34.23	838.38	10.38	1421746.	0.110	Bu	0.008
300.0	2109351.	215.41	0.26992	912070.	2801285.	28.80	33.43	837.06	10.57	1422012.	0.110	Bu	0.008

315.0	2133161.	215.99	0.26896	914693.	2801510.	28.43	32.96	836.29	10.69	1422171.	0.110	Bu	0.008
330.0	2156838.	216.56	0.26801	917282.	2801727.	28.07	32.51	835.52	10.81	1422330.	0.110	Bu	0.008
345.0	2180391.	217.11	0.26707	919838.	2801936.	27.72	32.07	834.77	10.92	1422488.	0.110	Bu	0.008
360.0	2203815.	217.67	0.26614	922361.	2802136.	27.39	31.65	834.02	11.04	1422645.	0.110	Bu	0.008
375.0	2227125.	218.21	0.26522	924853.	2802329.	27.05	31.23	833.28	11.15	1422802.	0.110	Bu	0.008
390.0	2250306.	218.75	0.26432	927313.	2802514.	26.73	30.83	832.55	11.27	1422958.	0.110	Bu	0.008
405.0	2273382.	219.28	0.26342	929744.	2802692.	26.42	30.44	831.83	11.38	1423114.	0.110	Bu	0.008
420.0	2296330.	219.80	0.26253	932145.	2802862.	26.11	30.05	831.11	11.49	1423269.	0.110	Bu	0.008
435.0	2319181.	220.32	0.26166	934519.	2803026.	25.81	29.68	830.40	11.60	1423423.	0.110	Bu	0.008
450.0	2341905.	220.83	0.26079	936864.	2803183.	25.52	29.32	829.70	11.72	1423581.	0.110	Bu	0.008
465.0	2364539.	221.33	0.25993	939183.	2803334.	25.23	28.96	829.01	11.83	1423738.	0.110	Bu	0.008
480.0	2387042.	221.83	0.25909	941475.	2803478.	24.95	28.62	828.33	11.94	1423894.	0.110	Bu	0.008
495.0	2409462.	222.33	0.25825	943742.	2803616.	24.68	28.28	827.65	12.05	1424050.	0.110	Bu	0.008
510.0	2431747.	222.81	0.25742	945982.	2803748.	24.41	27.95	826.98	12.16	1424204.	0.110	Bu	0.008
525.0	2453957.	223.29	0.25660	948200.	2803874.	24.15	27.63	826.31	12.27	1424357.	0.110	Bu	0.008
540.0	2476027.	223.77	0.25578	950391.	2803995.	23.90	27.32	825.66	12.38	1424509.	0.110	Bu	0.008
555.0	2498026.	224.24	0.25498	952561.	2804110.	23.65	27.01	825.01	12.49	1424661.	0.110	Bu	0.008
570.0	2519882.	224.70	0.25418	954704.	2804220.	23.41	26.71	824.36	12.60	1424810.	0.110	Bu	0.008
585.0	2541673.	225.16	0.25339	956827.	2804325.	23.17	26.42	823.72	12.70	1424960.	0.110	Bu	0.008
600.0	2563314.	225.61	0.25261	958924.	2804425.	22.93	26.13	823.09	12.81	1425107.	0.110	Bu	0.008
615.0	2584895.	226.06	0.25183	961003.	2804519.	22.71	25.85	822.47	12.92	1425255.	0.110	Bu	0.008
630.0	2606320.	226.51	0.25106	963055.	2804609.	22.48	25.58	821.85	13.03	1425400.	0.110	Bu	0.008
645.0	2627689.	226.95	0.25030	965090.	2804694.	22.26	25.31	821.24	13.13	1425545.	0.110	Bu	0.008
660.0	2648895.	227.38	0.24955	967099.	2804775.	22.05	25.05	820.63	13.24	1425687.	0.110	Bu	0.008
675.0	2670050.	227.81	0.24880	969091.	2804851.	21.84	24.79	820.03	13.34	1425829.	0.110	Bu	0.008
690.0	2691033.	228.23	0.24806	971057.	2804923.	21.63	24.54	819.43	13.45	1425969.	0.110	Bu	0.008
705.0	2711969.	228.65	0.24733	973008.	2804991.	21.43	24.30	818.84	13.55	1426109.	0.110	Bu	0.008
720.0	2732725.	229.06	0.24660	974932.	2805054.	21.24	24.06	818.26	13.65	1426246.	0.110	Bu	0.008
735.0	2753437.	229.47	0.24588	976842.	2805114.	21.04	23.82	817.68	13.76	1426383.	0.110	Bu	0.008
750.0	2773961.	229.88	0.24517	978725.	2805170.	20.85	23.59	817.11	13.86	1426518.	0.110	Bu	0.008
775.0	2808076.	230.55	0.24400	981835.	2805254.	20.54	23.22	816.17	14.03	1426744.	0.110	Bu	0.008
800.0	2842083.	231.20	0.24283	984908.	2805329.	20.25	22.86	815.24	14.20	1426970.	0.110	Bu	0.008
825.0	2875990.	231.85	0.24168	987948.	2805395.	19.95	22.51	814.31	14.37	1427195.	0.110	Bu	0.008
850.0	2909804.	232.50	0.24054	990956.	2805451.	19.67	22.16	813.40	14.54	1427420.	0.110	Bu	0.008
875.0	2943534.	233.13	0.23941	993932.	2805499.	19.39	21.83	812.49	14.71	1427644.	0.110	Bu	0.008
900.0	2977188.	233.76	0.23829	996879.	2805538.	19.12	21.50	811.59	14.87	1427868.	0.110	Bu	0.008
910.0	2990628.	234.01	0.23785	998050.	2805551.	19.01	21.38	811.24	14.94	1427956.	0.110	Bu	0.008
935.0	3073821.	235.54	0.23477	1005222.	2805604.	29.58	32.78	809.04	15.36	1427900.	0.087	Bu	0.008
960.0	3127326.	236.50	0.23296	1009764.	2805613.	28.93	32.02	807.65	15.63	1428132.	0.087	Bu	0.008
985.0	3180372.	237.45	0.23119	1014216.	2805602.	28.32	31.30	806.28	15.89	1428364.	0.087	Bu	0.008
1010.0	3232992.	238.37	0.22944	1018583.	2805573.	27.72	30.61	804.94	16.16	1428594.	0.087	Bu	0.008
1010.0	3232992.	238.37	0.22944	1018583.	2805573.	28.22	31.13	804.94	16.16	1428594.	0.087	Bu	0.008
1035.0	3286181.	239.29	0.22769	1022950.	2805527.	27.63	30.45	803.60	16.43	1428824.	0.087	Bu	0.008

1060.0	3338977.	240.20	0.22596	1027237.	2805463.	27.06	29.79	802.28	16.69	1429053.	0.087	Bu	0.008
1085.0	3391405.	241.08	0.22426	1031451.	2805383.	26.52	29.16	800.98	16.96	1429281.	0.087	Bu	0.008
1110.0	3443492.	241.96	0.22259	1035594.	2805288.	26.00	28.55	799.70	17.22	1429508.	0.087	Bu	0.008
1135.0	3495262.	242.81	0.22094	1039671.	2805178.	25.49	27.97	798.44	17.49	1429734.	0.087	Bu	0.008
1160.0	3546739.	243.65	0.21930	1043686.	2805053.	25.00	27.41	797.20	17.75	1429960.	0.087	Bu	0.008
1185.0	3597945.	244.48	0.21769	1047641.	2804915.	24.53	26.87	795.98	18.01	1430185.	0.087	Bu	0.008
1210.0	3648900.	245.30	0.21610	1051540.	2804765.	24.08	26.34	794.77	18.27	1430409.	0.087	Bu	0.008
1235.0	3699625.	246.10	0.21452	1055387.	2804601.	23.64	25.84	793.58	18.53	1430632.	0.087	Bu	0.008
1260.0	3750138.	246.89	0.21296	1059183.	2804425.	23.21	25.35	792.40	18.78	1430855.	0.087	Bu	0.008
1285.0	3800458.	247.67	0.21142	1062931.	2804238.	22.80	24.88	791.23	19.04	1431078.	0.087	Bu	0.008
1310.0	3850602.	248.44	0.20989	1066634.	2804039.	22.40	24.42	790.08	19.30	1431300.	0.087	Bu	0.008
1335.0	3900586.	249.20	0.20838	1070294.	2803828.	22.01	23.98	788.94	19.56	1431521.	0.087	Bu	0.008
1360.0	3950428.	249.95	0.20687	1073913.	2803607.	21.63	23.55	787.81	19.81	1431743.	0.087	Bu	0.008
1385.0	4000141.	250.69	0.20538	1077494.	2803376.	21.27	23.13	786.70	20.07	1431963.	0.087	Bu	0.008
1410.0	4049742.	251.42	0.20391	1081037.	2803134.	20.91	22.72	785.59	20.33	1432184.	0.087	Bu	0.008
1435.0	4099244.	252.14	0.20244	1084546.	2802882.	20.56	22.33	784.50	20.58	1432404.	0.087	Bu	0.008
1460.0	4148662.	252.86	0.20098	1088022.	2802620.	20.22	21.94	783.41	20.84	1432623.	0.087	Bu	0.008
1485.0	4198014.	253.57	0.19954	1091466.	2802348.	19.89	21.57	782.33	21.09	1432848.	0.087	Bu	0.008
1510.0	4247308.	254.27	0.19810	1094880.	2802067.	19.57	21.21	781.26	21.35	1433073.	0.087	Bu	0.008
1522.0	4289805.	254.87	0.19683	1097803.	2801817.	3.93	39.99	780.35	21.57	1433209.	0.087	Bu	0.008
1535.0	4395087.	256.33	0.19359	1104969.	2801166.	3.91	38.92	778.10	22.12	1433331.	0.087	Bu	0.008
1560.0	4601347.	259.13	0.18730	1118695.	2799773.	3.87	36.93	773.79	23.20	1433562.	0.087	Bu	0.008
1585.0	4812634.	261.89	0.18095	1132357.	2798192.	3.83	35.04	769.48	24.32	1433791.	0.087	Bu	0.008
1610.0	5028947.	264.63	0.17453	1145957.	2796424.	3.80	33.22	765.19	25.47	1434018.	0.087	Bu	0.008
1635.0	5250209.	267.34	0.16804	1159495.	2794472.	3.77	31.46	760.91	26.66	1434244.	0.087	Bu	0.008
1660.0	5476258.	270.02	0.16148	1172965.	2792337.	3.75	29.76	756.64	27.88	1434468.	0.087	Bu	0.008
1685.0	5706835.	272.66	0.15485	1186356.	2790022.	3.73	28.12	752.40	29.14	1434691.	0.087	Bu	0.008
1710.0	5941570.	275.28	0.14816	1199652.	2787535.	3.72	26.51	748.18	30.44	1434912.	0.087	Bu	0.008
1735.0	6179973.	277.85	0.14141	1212833.	2784881.	3.70	24.95	743.99	31.77	1435133.	0.087	Bu	0.008
1760.0	6421430.	280.38	0.13461	1225873.	2782071.	3.69	23.43	739.85	33.13	1435352.	0.087	Bu	0.008
1785.0	6665203.	282.86	0.12778	1238744.	2779117.	3.69	21.94	735.76	34.52	1435571.	0.087	Bu	0.008
1810.0	6910437.	285.29	0.12093	1251413.	2776034.	3.69	20.49	731.73	35.93	1435788.	0.087	Bu	0.008
1810.0	6910437.	285.36	0.08287	1248551.	2776430.	1.94	7.44	734.04	35.91	1375163.	0.087	Bu	0.010
1835.0	7127131.	287.45	0.07654	1259478.	2773627.	1.95	6.79	730.55	37.17	1375376.	0.087	Bu	0.010
1860.0	7339286.	289.45	0.07036	1269987.	2770808.	1.95	6.18	727.19	38.42	1375589.	0.087	Bu	0.010
1885.0	7546130.	291.36	0.06434	1280062.	2767991.	1.95	5.60	723.98	39.65	1375801.	0.087	Bu	0.010
1910.0	7747058.	293.17	0.05850	1289697.	2765192.	1.95	5.07	720.90	40.85	1376014.	0.087	Bu	0.010
1935.0	7941641.	294.90	0.05284	1298890.	2762426.	1.94	4.58	717.97	42.02	1376227.	0.087	Bu	0.010
1960.0	8129629.	296.53	0.04737	1307648.	2759705.	1.94	4.14	715.18	43.17	1376439.	0.087	Bu	0.010
1985.0	8310935.	298.08	0.04210	1315986.	2757036.	1.93	3.73	712.53	44.29	1376652.	0.087	Bu	0.010
2010.0	8485620.	299.55	0.03701	1323921.	2754424.	1.91	3.36	710.00	45.37	1376864.	0.087	Bu	0.010
2035.0	8653869.	300.94	0.03210	1331476.	2751873.	1.89	3.02	707.59	46.43	1377077.	0.087	Bu	0.010
2060.0	8815967.	302.27	0.02737	1338676.	2749384.	1.86	2.72	705.31	47.45	1377289.	0.087	Bu	0.010
2085.0	8972275.	303.52	0.02280	1345548.	2746955.	1.83	2.44	703.12	48.45	1377502.	0.087	Bu	0.010

2110.0	9123215.	304.72	0.01838	1352120.	2744584.	1.79	2.19	701.03	49.42	1377714.	0.087	Bu	0.010
2135.0	9269247.	305.87	0.01410	1358421.	2742266.	1.74	1.97	699.04	50.37	1377927.	0.087	Bu	0.010
2160.0	9411257.	306.97	0.00992	1364494.	2739990.	1.68	1.77	697.11	51.29	1378139.	0.087	Bu	0.010
2185.0	9551401.	308.04	0.00579	1370438.	2737725.	1.62	1.62	695.23	52.22	1378352.	0.087	Bu	0.010
2210.0	9695434.	309.13	0.00000	1378563.	2735371.	1.52	1.52	691.18	53.17	1378564.	0.087	Bu	0.010
2235.0	9843685.	309.54	0.00000	1378776.	2735338.	1.52	1.52	691.36	53.19	1378776.	0.087	1p	0.010
2260.0	9991976.	309.58	0.00000	1378988.	2735305.	1.52	1.52	691.55	53.20	1378988.	0.087	1p	0.010
2285.0	10140305.	309.62	0.00000	1379200.	0.	1.52	0.00	691.73	0.00	1379200.	0.087	1p	0.010
2310.0	10288673.	309.66	0.00000	1379413.	0.	1.52	0.00	691.92	0.00	1379413.	0.087	1p	0.010
2335.0	10437081.	309.70	0.00000	1379625.	0.	1.52	0.00	692.10	0.00	1379625.	0.087	1p	0.010
2360.0	10585528.	309.74	0.00000	1379838.	0.	1.52	0.00	692.29	0.00	1379838.	0.087	1p	0.010
2385.0	10734013.	309.78	0.00000	1380050.	0.	1.52	0.00	692.47	0.00	1380050.	0.087	1p	0.010
2410.0	10882538.	309.81	0.00000	1380262.	0.	1.52	0.00	692.66	0.00	1380262.	0.087	1p	0.010
2435.0	11031102.	309.85	0.00000	1380475.	0.	1.52	0.00	692.85	0.00	1380475.	0.087	1p	0.010
2460.0	11179704.	309.89	0.00000	1380687.	0.	1.51	0.00	693.03	0.00	1380687.	0.087	1p	0.010
2485.0	11328346.	309.93	0.00000	1380899.	0.	1.51	0.00	693.22	0.00	1380899.	0.087	1p	0.010
2510.0	11477027.	309.97	0.00000	1381112.	0.	1.51	0.00	693.40	0.00	1381112.	0.087	1p	0.010
2530.0	11596000.	310.00	0.00000	1381282.	0.	1.51	46.71	693.55	0.00	1381282.	0.087	1p	0.010
2530.0	11596000.	310.00	0.00000	1381282.	0.	1.51	46.71	693.55	0.00	1381282.	0.087	1p	0.010

APPENDIX C
(SAMPLE RUNS FOR HOLA)

SAMPLE 1 INPUT FILE

```

Sample 1 for Simulator HOLA
- Option 1 used -
- The well is producing two-phase fluid at the wellhead -
0.7000E+06
1.3000E+06
100.0000

2530.000
2.000
2800.000
1000.000
6.0480E+05
20
  300.0  0.1102  4.6E-5    25.0   90.0
    30.0  0.1102  4.6E-5    15.0   88.0
    30.0  0.1102  4.6E-5    15.0   86.0
    30.0  0.1102  4.6E-5    15.0   84.0
    30.0  0.1102  4.6E-5    15.0   82.0
    30.0  0.1102  4.6E-5    15.0   80.0
    30.0  0.1102  4.6E-5    15.0   78.0
    30.0  0.1102  4.6E-5    15.0   76.0
    30.0  0.1102  4.6E-5    15.0   74.0
    30.0  0.1102  4.6E-5    15.0   72.0
    30.0  0.1102  4.6E-5    15.0   70.0
    30.0  0.1102  4.6E-5    15.0   68.0
    30.0  0.1102  4.6E-5    15.0   66.0
    30.0  0.1102  4.6E-5    15.0   64.0
    30.0  0.1102  4.6E-5    15.0   62.0
    30.0  0.1102  4.6E-5    15.0   60.0
   150.0  0.1102  4.6E-5    25.0   60.0
    10.0  0.1102  4.6E-5    10.0   60.0
  1600.0  0.0873  1.5E-5    25.0   60.0
    20.0  0.0873  1.5E-5    20.0   60.0
4
  0.0    25.00
 1000.0  260.00
 2000.0  310.00
 2500.0  330.00
3
 1110.0 -10.00    1.0000E+06
 1810.0  40.00    1.5000E+06

```

SAMPLE 1 HOLA.LOG FILE

```

Two phase to water phase
Pressure      X2      Depth
0.834715E+07 -0.00033092  1235.0

```

SAMPLE 1 OUTPUT FILE

HOLA - MODEL RESULTS

Sample 1 for Simulator HOLA

- Option 1 used -

- The well is producing two-phase fluid at the wellhead -

Wellhead pressure (bar abs.) : 7.00
 Wellhead temperature (C) : 164.96
 Wellhead dryness : 0.292
 Wellhead enthalpy (kJ/kg) : 1300.00
 Wellhead total flow (kg/s) : 100.00

Feedzone no:	Depth (m)	Flow (kg/s)	Enthalpy (kJ/kg)
1	1110.0	-10.0000	1331.9
2	1810.0	40.0000	1500.0
3	2530.0	70.0000	1250.3

88

Depth (m)	Press (Pa)	Temp (C)	Dryness	Hw (J/kg)	Hs (J/kg)	Vw (m/s)	Vs (m/s)	Dw (kg/m3)	Ds (kg/m3)	H_t (J/kg)	Rad (m)	Reg
0.0	700000.	164.96	0.29199	697061.	2762005.	172.10	211.22	902.37	3.67	1300000.	0.110	Mi
25.0	1145098.	185.86	0.26232	789068.	2781146.	103.11	119.92	880.60	5.86	1311624.	0.110	Mi
50.0	1324071.	192.45	0.25170	818478.	2786077.	87.62	100.54	873.30	6.73	1313729.	0.110	Tr
75.0	1471438.	197.38	0.24349	840570.	2789381.	77.57	88.20	867.71	7.46	1315093.	0.110	Sl
100.0	1600442.	201.38	0.23666	858621.	2791819.	70.25	79.33	863.07	8.09	1316128.	0.110	Sl
125.0	1717067.	204.79	0.23073	874054.	2793713.	64.55	72.49	859.05	8.66	1316985.	0.110	Sl
150.0	1824643.	207.78	0.22547	887633.	2795234.	59.94	66.99	855.48	9.19	1317731.	0.110	Sl
175.0	1925256.	210.46	0.22069	899823.	2796480.	56.08	62.44	852.25	9.68	1318404.	0.110	Sl
200.0	2020318.	212.89	0.21631	910931.	2797516.	52.79	58.57	849.27	10.15	1319023.	0.110	Sl
225.0	2110841.	215.12	0.21225	921169.	2798387.	49.93	55.23	846.51	10.59	1319602.	0.110	Sl
250.0	2197577.	217.19	0.20844	930691.	2799123.	47.41	52.30	843.92	11.02	1320150.	0.110	Sl
275.0	2281109.	219.12	0.20485	939615.	2799749.	45.17	49.70	841.48	11.43	1320672.	0.110	Sl
300.0	2361895.	220.94	0.20145	948030.	2800281.	43.15	47.37	839.16	11.83	1321174.	0.110	Sl

315.0	2409193.	221.98	0.19949	952864.	2800561.	42.04	46.09	837.83	12.06	1321466.	0.110	SI
330.0	2455706.	222.99	0.19758	957553.	2800815.	40.98	44.88	836.52	12.29	1321752.	0.110	SI
345.0	2501478.	223.97	0.19572	962108.	2801044.	39.98	43.73	835.26	12.52	1322032.	0.110	SI
360.0	2546581.	224.93	0.19391	966540.	2801251.	39.04	42.65	834.02	12.74	1322308.	0.110	SI
375.0	2591034.	225.85	0.19214	970856.	2801437.	38.13	41.62	832.81	12.97	1322577.	0.110	SI
390.0	2634912.	226.75	0.19040	975065.	2801604.	37.27	40.64	831.62	13.18	1322843.	0.110	SI
405.0	2678210.	227.63	0.18871	979172.	2801753.	36.45	39.70	830.47	13.40	1323103.	0.110	SI
420.0	2721012.	228.49	0.18704	983188.	2801886.	35.67	38.81	829.33	13.61	1323359.	0.110	SI
435.0	2763291.	229.33	0.18541	987111.	2802002.	34.92	37.96	828.22	13.82	1323611.	0.110	SI
450.0	2805140.	230.15	0.18381	990955.	2802103.	34.20	37.14	827.12	14.03	1323859.	0.110	SI
465.0	2846509.	230.95	0.18224	994716.	2802191.	33.51	36.36	826.05	14.24	1324102.	0.110	SI
480.0	2887503.	231.73	0.18069	998407.	2802265.	32.84	35.61	825.00	14.44	1324342.	0.110	SI
495.0	2928052.	232.50	0.17917	1002022.	2802327.	32.21	34.89	823.96	14.65	1324577.	0.110	SI
510.0	2968275.	233.25	0.17767	1005575.	2802377.	31.59	34.20	822.94	14.85	1324808.	0.110	SI
525.0	3008078.	233.99	0.17619	1009058.	2802415.	31.00	33.53	821.93	15.05	1325035.	0.110	SI
540.0	3047595.	234.72	0.17474	1012486.	2802443.	30.43	32.89	820.94	15.25	1325259.	0.110	SI
555.0	3086713.	235.43	0.17330	1015850.	2802461.	29.87	32.27	819.97	15.44	1325479.	0.110	SI
570.0	3125581.	236.13	0.17189	1019164.	2802469.	29.34	31.67	819.01	15.64	1325695.	0.110	SI
585.0	3164062.	236.81	0.17049	1022418.	2802468.	28.82	31.09	818.06	15.83	1325906.	0.110	SI
600.0	3202326.	237.49	0.16911	1025627.	2802457.	28.32	30.53	817.12	16.03	1326115.	0.110	SI
615.0	3240211.	238.15	0.16775	1028779.	2802439.	27.84	29.99	816.20	16.22	1326319.	0.110	SI
630.0	3277906.	238.80	0.16641	1031891.	2802412.	27.37	29.47	815.29	16.41	1326520.	0.110	SI
645.0	3315226.	239.44	0.16508	1034948.	2802377.	26.92	28.96	814.39	16.60	1326716.	0.110	SI
660.0	3352381.	240.08	0.16376	1037969.	2802335.	26.48	28.47	813.51	16.78	1326910.	0.110	SI
675.0	3389161.	240.70	0.16247	1040938.	2802286.	26.05	28.00	812.63	16.97	1327098.	0.110	SI
690.0	3425797.	241.31	0.16118	1043874.	2802229.	25.63	27.53	811.76	17.16	1327284.	0.110	SI
705.0	3543846.	243.26	0.15691	1053194.	2802000.	5.18	49.04	809.00	17.76	1327591.	0.110	SI
720.0	3674421.	245.35	0.15216	1063267.	2801666.	5.13	46.80	805.98	18.42	1327783.	0.110	SI
735.0	3804811.	247.38	0.14748	1073094.	2801252.	5.08	44.79	803.03	19.09	1327968.	0.110	SI
750.0	3937150.	249.40	0.14279	1082846.	2800755.	5.04	42.74	800.07	19.77	1328150.	0.110	SI
775.0	4161386.	252.69	0.13496	1098895.	2799745.	4.98	39.48	795.16	20.93	1328447.	0.110	SI
800.0	4389935.	255.91	0.12712	1114692.	2798517.	4.94	36.39	790.27	22.13	1328737.	0.110	SI
825.0	4622255.	259.05	0.11926	1130224.	2797077.	4.90	33.45	785.41	23.35	1329019.	0.110	SI
850.0	4857567.	262.11	0.11141	1145464.	2795436.	4.87	30.63	780.59	24.60	1329296.	0.110	SI
875.0	5094843.	265.09	0.10359	1160375.	2793609.	4.85	27.94	775.82	25.87	1329565.	0.110	SI
900.0	5332825.	267.97	0.09582	1174910.	2791613.	4.84	25.36	771.12	27.15	1329829.	0.110	SI
910.0	5427942.	269.09	0.09274	1180610.	2790771.	4.84	24.36	769.26	27.67	1329933.	0.110	SI
935.0	5661605.	271.79	0.08517	1194361.	2788602.	7.45	37.33	764.75	28.95	1330135.	0.087	SI
960.0	5942978.	274.93	0.07612	1210482.	2785807.	7.45	32.79	759.41	30.51	1330398.	0.087	SI
985.0	6216612.	277.87	0.06738	1225738.	2782907.	7.46	28.56	754.29	32.04	1330653.	0.087	SI
1010.0	6480278.	280.62	0.05898	1240078.	2779952.	7.47	24.69	749.43	33.53	1330901.	0.087	SI
1035.0	6732220.	283.16	0.05098	1253476.	2776986.	7.47	21.19	744.84	34.97	1331146.	0.087	SI
1060.0	6971313.	285.51	0.04340	1265937.	2774050.	7.45	18.09	740.53	36.36	1331391.	0.087	SI

06

1085.0	7197111.	287.67	0.03625	1277492.	2771171.	7.40	15.37	736.50	37.68	1331635.	0.087	sl
1110.0	7409798.	289.66	0.02951	1288199.	2768369.	7.31	13.02	732.73	38.94	1331880.	0.087	sl
1110.0	7409798.	289.66	0.02951	1288199.	2768369.	8.01	14.48	732.73	38.94	1331880.	0.087	sl
1135.0	7617584.	291.57	0.02292	1298504.	2765549.	7.85	12.14	729.08	40.18	1332123.	0.087	sl
1160.0	7813146.	293.32	0.01670	1308070.	2762823.	7.62	10.14	725.66	41.36	1332367.	0.087	sl
1185.0	7997969.	294.95	0.01082	1316999.	2760185.	7.30	8.44	722.45	42.49	1332611.	0.087	sl
1210.0	8174593.	296.48	0.00518	1325435.	2757608.	6.89	7.07	719.40	43.57	1332856.	0.087	Bu
1235.0	8354269.	297.86	0.00000	1333103.	0.	6.41	0.00	716.63	0.00	1333103.	0.087	1p
1260.0	8531547.	297.94	0.00000	1333345.	0.	6.41	0.00	716.85	0.00	1333345.	0.087	1p
1285.0	8708863.	298.02	0.00000	1333586.	0.	6.41	0.00	717.06	0.00	1333586.	0.087	1p
1310.0	8886217.	298.10	0.00000	1333826.	0.	6.41	0.00	717.27	0.00	1333826.	0.087	1p
1335.0	9063609.	298.18	0.00000	1334064.	0.	6.40	0.00	717.48	0.00	1334064.	0.087	1p
1360.0	9241038.	298.25	0.00000	1334301.	0.	6.40	0.00	717.69	0.00	1334301.	0.087	1p
1385.0	9418506.	298.33	0.00000	1334536.	0.	6.40	0.00	717.91	0.00	1334536.	0.087	1p
1410.0	9596011.	298.41	0.00000	1334771.	0.	6.40	0.00	718.12	0.00	1334771.	0.087	1p
1435.0	9773553.	298.48	0.00000	1335003.	0.	6.40	0.00	718.33	0.00	1335003.	0.087	1p
1460.0	9951134.	298.56	0.00000	1335235.	0.	6.39	0.00	718.54	0.00	1335235.	0.087	1p
1485.0	10128753.	298.63	0.00000	1335465.	0.	6.39	0.00	718.76	0.00	1335465.	0.087	1p
1510.0	10306409.	298.71	0.00000	1335693.	0.	6.39	0.00	718.97	0.00	1335693.	0.087	1p
1535.0	10484103.	298.78	0.00000	1335921.	0.	6.39	0.00	719.18	0.00	1335921.	0.087	1p
1560.0	10661835.	298.85	0.00000	1336147.	0.	6.39	0.00	719.39	0.00	1336147.	0.087	1p
1585.0	10839605.	298.93	0.00000	1336371.	0.	6.38	0.00	719.61	0.00	1336371.	0.087	1p
1610.0	11017414.	299.00	0.00000	1336595.	0.	6.38	0.00	719.82	0.00	1336595.	0.087	1p
1635.0	11195260.	299.07	0.00000	1336817.	0.	6.38	0.00	720.03	0.00	1336817.	0.087	1p
1660.0	11373144.	299.15	0.00000	1337037.	0.	6.38	0.00	720.25	0.00	1337037.	0.087	1p
1685.0	11551066.	299.22	0.00000	1337256.	0.	6.38	0.00	720.46	0.00	1337256.	0.087	1p
1710.0	11729026.	299.29	0.00000	1337474.	0.	6.37	0.00	720.67	0.00	1337474.	0.087	1p
1735.0	11907024.	299.36	0.00000	1337691.	0.	6.37	0.00	720.89	0.00	1337691.	0.087	1p
1760.0	12085060.	299.43	0.00000	1337906.	0.	6.37	0.00	721.10	0.00	1337906.	0.087	1p
1785.0	12263134.	299.50	0.00000	1338119.	0.	6.37	0.00	721.31	0.00	1338119.	0.087	1p
1810.0	12441246.	299.57	0.00000	1338332.	0.	6.37	0.00	721.53	0.00	1338332.	0.087	1p
1810.0	12441246.	282.34	0.00000	1245950.	0.	3.87	0.00	755.89	0.00	1245950.	0.087	1p
1835.0	12611546.	282.39	0.00000	1246129.	0.	3.87	0.00	756.06	0.00	1246129.	0.087	1p
1860.0	12781880.	282.44	0.00000	1246305.	0.	3.87	0.00	756.24	0.00	1246305.	0.087	1p
1885.0	12952250.	282.49	0.00000	1246479.	0.	3.87	0.00	756.41	0.00	1246479.	0.087	1p
1910.0	13122654.	282.53	0.00000	1246651.	0.	3.86	0.00	756.59	0.00	1246651.	0.087	1p
1935.0	13293094.	282.58	0.00000	1246821.	0.	3.86	0.00	756.77	0.00	1246821.	0.087	1p
1960.0	13463569.	282.63	0.00000	1246989.	0.	3.86	0.00	756.94	0.00	1246989.	0.087	1p
1985.0	13634080.	282.68	0.00000	1247154.	0.	3.86	0.00	757.12	0.00	1247154.	0.087	1p
2010.0	13804626.	282.72	0.00000	1247318.	0.	3.86	0.00	757.30	0.00	1247318.	0.087	1p
2035.0	13975208.	282.77	0.00000	1247479.	0.	3.86	0.00	757.48	0.00	1247479.	0.087	1p
2060.0	14145826.	282.81	0.00000	1247639.	0.	3.86	0.00	757.66	0.00	1247639.	0.087	1p
2085.0	14316479.	282.86	0.00000	1247797.	0.	3.86	0.00	757.83	0.00	1247797.	0.087	1p

2110.0	14487168.	282.90	0.00000	1247953.	0.	3.86	0.00	758.01	0.00	1247953.	0.087	1p
2135.0	14657893.	282.95	0.00000	1248108.	0.	3.86	0.00	758.19	0.00	1248108.	0.087	1p
2160.0	14828654.	282.99	0.00000	1248261.	0.	3.86	0.00	758.37	0.00	1248261.	0.087	1p
2185.0	14999451.	283.03	0.00000	1248412.	0.	3.85	0.00	758.55	0.00	1248412.	0.087	1p
2210.0	15170285.	283.08	0.00000	1248562.	0.	3.85	0.00	758.73	0.00	1248562.	0.087	1p
2235.0	15341154.	283.12	0.00000	1248709.	0.	3.85	0.00	758.92	0.00	1248709.	0.087	1p
2260.0	15512060.	283.16	0.00000	1248855.	0.	3.85	0.00	759.10	0.00	1248855.	0.087	1p
2285.0	15683002.	283.20	0.00000	1248999.	0.	3.85	0.00	759.28	0.00	1248999.	0.087	1p
2310.0	15853980.	283.24	0.00000	1249142.	0.	3.85	0.00	759.46	0.00	1249142.	0.087	1p
2335.0	16024995.	283.29	0.00000	1249283.	0.	3.85	0.00	759.64	0.00	1249283.	0.087	1p
2360.0	16196046.	283.33	0.00000	1249421.	0.	3.85	0.00	759.83	0.00	1249421.	0.087	1p
2385.0	16367134.	283.37	0.00000	1249559.	0.	3.85	0.00	760.01	0.00	1249559.	0.087	1p
2410.0	16538259.	283.41	0.00000	1249694.	0.	3.85	0.00	760.19	0.00	1249694.	0.087	1p
2435.0	16709420.	283.44	0.00000	1249828.	0.	3.84	0.00	760.38	0.00	1249828.	0.087	1p
2460.0	16880618.	283.48	0.00000	1249960.	0.	3.84	0.00	760.56	0.00	1249960.	0.087	1p
2485.0	17051853.	283.52	0.00000	1250090.	0.	3.84	0.00	760.74	0.00	1250090.	0.087	1p
2510.0	17223125.	283.56	0.00000	1250219.	0.	3.84	0.00	760.93	0.00	1250219.	0.087	1p
2530.0	17360170.	283.59	0.00000	1250320.	0.	3.84	0.00	761.08	0.00	1250320.	0.087	1p

SAMPLE 2 INPUT FILE

```

Sample 2 for Simulator HOLA
- Option 1 used , the well is injecting separated
  single-phase waste water-
0.4000E+06
700.0E+03
-100.000

2530.000
0.000
2800.000
1000.000
6.0480E+05
20
  300.0  0.1102  4.6E-5    25.0   90.0
    30.0  0.1102  4.6E-5    15.0   88.0
    30.0  0.1102  4.6E-5    15.0   86.0
    30.0  0.1102  4.6E-5    15.0   84.0
    30.0  0.1102  4.6E-5    15.0   82.0
    30.0  0.1102  4.6E-5    15.0   80.0
    30.0  0.1102  4.6E-5    15.0   78.0
    30.0  0.1102  4.6E-5    15.0   76.0
    30.0  0.1102  4.6E-5    15.0   74.0
    30.0  0.1102  4.6E-5    15.0   72.0
    30.0  0.1102  4.6E-5    15.0   70.0
    30.0  0.1102  4.6E-5    15.0   68.0
    30.0  0.1102  4.6E-5    15.0   66.0
    30.0  0.1102  4.6E-5    15.0   64.0
    30.0  0.1102  4.6E-5    15.0   62.0
    30.0  0.1102  4.6E-5    15.0   60.0
   150.0  0.1102  4.6E-5    25.0   60.0
    10.0  0.1102  4.6E-5    10.0   60.0
  1600.0  0.0873  1.5E-5    25.0   60.0
    20.0  0.0873  1.5E-5    20.0   60.0
4
  0.0    25.00
 1000.0  260.00
 2000.0  310.00
 2500.0  330.00
3
 1110.0 -40.00    0.0000E+06
 1810.0 -40.00    0.0000E+06

```

SAMPLE 2 HOLA.LOG FILE

```

Two phase to water phase
Pressure          X2          Depth
0.817824E+06    -0.01470524    25.0

```

SAMPLE 2 OUTPUT FILE

HOLA - MODEL RESULTS

Sample 2 for Simulator HOLA

- Option 1 used , the well is injecting separated single-phase waste water-

Wellhead pressure (bar abs.) : 4.00
 Wellhead temperature (C) : 143.62
 Wellhead dryness : 0.045
 Wellhead enthalpy (kJ/kg) : 700.00
 Wellhead total flow (kg/s) : -100.00

Feedzone no:	Depth (m)	Flow (kg/s)	Enthalpy (kJ/kg)
1	1110.0	-40.0000	711.2
2	1810.0	-40.0000	717.2
3	2530.0	-20.0000	723.3

93

Depth (m)	Press (Pa)	Temp (C)	Dryness	Hw (J/kg)	Hs (J/kg)	Vw (m/s)	Vs (m/s)	Dw (kg/m ³)	Ds (kg/m ³)	H_t (J/kg)	Rad (m)	Reg
0.0	400000.	143.62	0.04469	604670.	2737639.	-45.09	-57.62	922.62	2.16	700000.	0.110	sl
25.0	740281.	165.91	0.00000	701257.	0.	-2.91	0.00	901.43	0.00	701257.	0.110	1p
50.0	967483.	165.94	0.00000	701503.	0.	-2.91	0.00	901.55	0.00	701503.	0.110	1p
75.0	1194714.	165.97	0.00000	701748.	0.	-2.91	0.00	901.67	0.00	701748.	0.110	1p
100.0	1421972.	165.99	0.00000	701993.	0.	-2.91	0.00	901.78	0.00	701993.	0.110	1p
125.0	1649258.	166.02	0.00000	702239.	0.	-2.91	0.00	901.90	0.00	702239.	0.110	1p
150.0	1876572.	166.05	0.00000	702484.	0.	-2.91	0.00	902.02	0.00	702484.	0.110	1p
175.0	2103914.	166.08	0.00000	702729.	0.	-2.91	0.00	902.13	0.00	702729.	0.110	1p
200.0	2331284.	166.10	0.00000	702974.	0.	-2.91	0.00	902.25	0.00	702974.	0.110	1p
225.0	2558681.	166.13	0.00000	703220.	0.	-2.90	0.00	902.37	0.00	703220.	0.110	1p
250.0	2786106.	166.16	0.00000	703465.	0.	-2.90	0.00	902.48	0.00	703465.	0.110	1p
275.0	3013559.	166.18	0.00000	703710.	0.	-2.90	0.00	902.60	0.00	703710.	0.110	1p
300.0	3241039.	166.21	0.00000	703956.	0.	-2.90	0.00	902.71	0.00	703956.	0.110	1p

315.0	3377460.	166.23	0.00000	704103.	0.	-2.90	0.00	902.78	0.00	704103.	0.110	1p
330.0	3513891.	166.24	0.00000	704250.	0.	-2.90	0.00	902.85	0.00	704250.	0.110	1p
345.0	3650089.	166.26	0.00000	704396.	0.	-2.90	0.00	902.92	0.00	704396.	0.110	1p
360.0	3786296.	166.27	0.00000	704543.	0.	-2.90	0.00	902.99	0.00	704543.	0.110	1p
375.0	3922110.	166.29	0.00000	704690.	0.	-2.90	0.00	903.06	0.00	704690.	0.110	1p
390.0	4057933.	166.31	0.00000	704836.	0.	-2.90	0.00	903.13	0.00	704836.	0.110	1p
405.0	4193201.	166.32	0.00000	704982.	0.	-2.90	0.00	903.20	0.00	704982.	0.110	1p
420.0	4328478.	166.34	0.00000	705127.	0.	-2.90	0.00	903.27	0.00	705127.	0.110	1p
435.0	4463039.	166.35	0.00000	705272.	0.	-2.90	0.00	903.34	0.00	705272.	0.110	1p
450.0	4597610.	166.37	0.00000	705417.	0.	-2.90	0.00	903.40	0.00	705417.	0.110	1p
465.0	4731306.	166.38	0.00000	705561.	0.	-2.90	0.00	903.47	0.00	705561.	0.110	1p
480.0	4865010.	166.40	0.00000	705705.	0.	-2.90	0.00	903.54	0.00	705705.	0.110	1p
495.0	4997680.	166.42	0.00000	705848.	0.	-2.90	0.00	903.61	0.00	705848.	0.110	1p
510.0	5130360.	166.43	0.00000	705991.	0.	-2.90	0.00	903.67	0.00	705991.	0.110	1p
525.0	5261847.	166.45	0.00000	706132.	0.	-2.90	0.00	903.74	0.00	706132.	0.110	1p
540.0	5393343.	166.46	0.00000	706274.	0.	-2.90	0.00	903.81	0.00	706274.	0.110	1p
555.0	5523492.	166.48	0.00000	706414.	0.	-2.90	0.00	903.87	0.00	706414.	0.110	1p
570.0	5653649.	166.49	0.00000	706554.	0.	-2.90	0.00	903.94	0.00	706554.	0.110	1p
585.0	5782303.	166.51	0.00000	706692.	0.	-2.90	0.00	904.00	0.00	706692.	0.110	1p
600.0	5910966.	166.52	0.00000	706830.	0.	-2.90	0.00	904.07	0.00	706830.	0.110	1p
615.0	6037974.	166.54	0.00000	706967.	0.	-2.90	0.00	904.13	0.00	706967.	0.110	1p
630.0	6164990.	166.55	0.00000	707103.	0.	-2.90	0.00	904.20	0.00	707103.	0.110	1p
645.0	6290200.	166.57	0.00000	707237.	0.	-2.90	0.00	904.26	0.00	707237.	0.110	1p
660.0	6415418.	166.58	0.00000	707372.	0.	-2.90	0.00	904.32	0.00	707372.	0.110	1p
675.0	6538681.	166.59	0.00000	707504.	0.	-2.90	0.00	904.38	0.00	707504.	0.110	1p
690.0	6661952.	166.61	0.00000	707636.	0.	-2.90	0.00	904.45	0.00	707636.	0.110	1p
705.0	6783122.	166.62	0.00000	707766.	0.	-2.90	0.00	904.51	0.00	707766.	0.110	1p
720.0	6904300.	166.64	0.00000	707896.	0.	-2.90	0.00	904.57	0.00	707896.	0.110	1p
735.0	7023232.	166.65	0.00000	708024.	0.	-2.90	0.00	904.63	0.00	708024.	0.110	1p
750.0	7142172.	166.66	0.00000	708151.	0.	-2.90	0.00	904.69	0.00	708151.	0.110	1p
775.0	7340422.	166.69	0.00000	708364.	0.	-2.90	0.00	904.79	0.00	708364.	0.110	1p
800.0	7538693.	166.71	0.00000	708576.	0.	-2.90	0.00	904.89	0.00	708576.	0.110	1p
825.0	7736983.	166.73	0.00000	708788.	0.	-2.90	0.00	904.99	0.00	708788.	0.110	1p
850.0	7935294.	166.76	0.00000	709001.	0.	-2.90	0.00	905.09	0.00	709001.	0.110	1p
875.0	8133626.	166.78	0.00000	709213.	0.	-2.90	0.00	905.18	0.00	709213.	0.110	1p
900.0	8331978.	166.80	0.00000	709426.	0.	-2.90	0.00	905.28	0.00	709426.	0.110	1p
910.0	8411325.	166.81	0.00000	709511.	0.	-2.90	0.00	905.32	0.00	709511.	0.110	1p
935.0	8602817.	166.83	0.00000	709717.	0.	-4.61	0.00	905.42	0.00	709717.	0.087	1p
960.0	8811808.	166.85	0.00000	709929.	0.	-4.61	0.00	905.53	0.00	709929.	0.087	1p
985.0	9020819.	166.87	0.00000	710141.	0.	-4.61	0.00	905.63	0.00	710141.	0.087	1p
1010.0	9229851.	166.90	0.00000	710354.	0.	-4.61	0.00	905.74	0.00	710354.	0.087	1p
1035.0	9438904.	166.92	0.00000	710566.	0.	-4.61	0.00	905.85	0.00	710566.	0.087	1p
1060.0	9647978.	166.94	0.00000	710779.	0.	-4.61	0.00	905.95	0.00	710779.	0.087	1p

1085.0	9857072.	166.96	0.00000	710991.	0.	-4.61	0.00	906.06	0.00	710991.	0.087	1p
1110.0	10066187.	166.98	0.00000	711203.	0.	-4.61	0.00	906.16	0.00	711203.	0.087	1p
1110.0	10066187.	166.98	0.00000	711203.	0.	-2.77	0.00	906.16	0.00	711203.	0.087	1p
1135.0	10264788.	167.00	0.00000	711416.	0.	-2.77	0.00	906.26	0.00	711416.	0.087	1p
1160.0	10463409.	167.03	0.00000	711628.	0.	-2.76	0.00	906.36	0.00	711628.	0.087	1p
1185.0	10662050.	167.05	0.00000	711841.	0.	-2.76	0.00	906.46	0.00	711841.	0.087	1p
1210.0	10860711.	167.07	0.00000	712053.	0.	-2.76	0.00	906.56	0.00	712053.	0.087	1p
1235.0	11059393.	167.09	0.00000	712266.	0.	-2.76	0.00	906.66	0.00	712266.	0.087	1p
1260.0	11258095.	167.12	0.00000	712478.	0.	-2.76	0.00	906.75	0.00	712478.	0.087	1p
1285.0	11456817.	167.14	0.00000	712690.	0.	-2.76	0.00	906.85	0.00	712690.	0.087	1p
1310.0	11655559.	167.16	0.00000	712903.	0.	-2.76	0.00	906.95	0.00	712903.	0.087	1p
1335.0	11854321.	167.18	0.00000	713115.	0.	-2.76	0.00	907.05	0.00	713115.	0.087	1p
1360.0	12053104.	167.21	0.00000	713328.	0.	-2.76	0.00	907.15	0.00	713328.	0.087	1p
1385.0	12251907.	167.23	0.00000	713540.	0.	-2.76	0.00	907.24	0.00	713540.	0.087	1p
1410.0	12450729.	167.25	0.00000	713752.	0.	-2.76	0.00	907.34	0.00	713752.	0.087	1p
1435.0	12649572.	167.28	0.00000	713965.	0.	-2.76	0.00	907.44	0.00	713965.	0.087	1p
1460.0	12848435.	167.30	0.00000	714177.	0.	-2.76	0.00	907.54	0.00	714177.	0.087	1p
1485.0	13047319.	167.32	0.00000	714390.	0.	-2.76	0.00	907.63	0.00	714390.	0.087	1p
1510.0	13246222.	167.34	0.00000	714602.	0.	-2.76	0.00	907.73	0.00	714602.	0.087	1p
1535.0	13445145.	167.37	0.00000	714814.	0.	-2.76	0.00	907.83	0.00	714814.	0.087	1p
1560.0	13644088.	167.39	0.00000	715027.	0.	-2.76	0.00	907.93	0.00	715027.	0.087	1p
1585.0	13843052.	167.41	0.00000	715239.	0.	-2.76	0.00	908.02	0.00	715239.	0.087	1p
1610.0	14042035.	167.43	0.00000	715452.	0.	-2.76	0.00	908.12	0.00	715452.	0.087	1p
1635.0	14241038.	167.46	0.00000	715664.	0.	-2.76	0.00	908.22	0.00	715664.	0.087	1p
1660.0	14440062.	167.48	0.00000	715876.	0.	-2.76	0.00	908.31	0.00	715876.	0.087	1p
1685.0	14639105.	167.50	0.00000	716089.	0.	-2.76	0.00	908.41	0.00	716089.	0.087	1p
1710.0	14838168.	167.52	0.00000	716301.	0.	-2.76	0.00	908.51	0.00	716301.	0.087	1p
1735.0	15037251.	167.54	0.00000	716514.	0.	-2.76	0.00	908.60	0.00	716514.	0.087	1p
1760.0	15236355.	167.57	0.00000	716726.	0.	-2.76	0.00	908.70	0.00	716726.	0.087	1p
1785.0	15435478.	167.59	0.00000	716939.	0.	-2.76	0.00	908.80	0.00	716939.	0.087	1p
1810.0	15634621.	167.61	0.00000	717151.	0.	-2.76	0.00	908.89	0.00	717151.	0.087	1p
1810.0	15634621.	167.61	0.00000	717151.	0.	-0.92	0.00	908.89	0.00	717151.	0.087	1p
1835.0	15828408.	167.64	0.00000	717363.	0.	-0.92	0.00	908.99	0.00	717363.	0.087	1p
1860.0	16022216.	167.66	0.00000	717576.	0.	-0.92	0.00	909.08	0.00	717576.	0.087	1p
1885.0	16216043.	167.68	0.00000	717788.	0.	-0.92	0.00	909.17	0.00	717788.	0.087	1p
1910.0	16409890.	167.70	0.00000	718001.	0.	-0.92	0.00	909.26	0.00	718001.	0.087	1p
1935.0	16603756.	167.73	0.00000	718213.	0.	-0.92	0.00	909.36	0.00	718213.	0.087	1p
1960.0	16797642.	167.75	0.00000	718425.	0.	-0.92	0.00	909.45	0.00	718425.	0.087	1p
1985.0	16991547.	167.77	0.00000	718638.	0.	-0.92	0.00	909.54	0.00	718638.	0.087	1p
2010.0	17185472.	167.80	0.00000	718850.	0.	-0.92	0.00	909.63	0.00	718850.	0.087	1p
2035.0	17379416.	167.82	0.00000	719063.	0.	-0.92	0.00	909.72	0.00	719063.	0.087	1p
2060.0	17573380.	167.84	0.00000	719275.	0.	-0.92	0.00	909.82	0.00	719275.	0.087	1p
2085.0	17767363.	167.87	0.00000	719487.	0.	-0.92	0.00	909.91	0.00	719487.	0.087	1p

2110.0	17961366.	167.89	0.00000	719700.	0.	-0.92	0.00	910.00	0.00	719700.	0.087	1p
2135.0	18155388.	167.91	0.00000	719912.	0.	-0.92	0.00	910.09	0.00	719912.	0.087	1p
2160.0	18349430.	167.93	0.00000	720125.	0.	-0.92	0.00	910.18	0.00	720125.	0.087	1p
2185.0	18543490.	167.96	0.00000	720337.	0.	-0.92	0.00	910.28	0.00	720337.	0.087	1p
2210.0	18737571.	167.98	0.00000	720549.	0.	-0.92	0.00	910.37	0.00	720549.	0.087	1p
2235.0	18931671.	168.00	0.00000	720762.	0.	-0.92	0.00	910.46	0.00	720762.	0.087	1p
2260.0	19125790.	168.03	0.00000	720974.	0.	-0.92	0.00	910.55	0.00	720974.	0.087	1p
2285.0	19319928.	168.05	0.00000	721187.	0.	-0.92	0.00	910.64	0.00	721187.	0.087	1p
2310.0	19514086.	168.07	0.00000	721399.	0.	-0.92	0.00	910.73	0.00	721399.	0.087	1p
2335.0	19708263.	168.10	0.00000	721611.	0.	-0.92	0.00	910.82	0.00	721611.	0.087	1p
2360.0	19902460.	168.12	0.00000	721824.	0.	-0.92	0.00	910.92	0.00	721824.	0.087	1p
2385.0	20096676.	168.14	0.00000	722036.	0.	-0.92	0.00	911.01	0.00	722036.	0.087	1p
2410.0	20290911.	168.16	0.00000	722249.	0.	-0.92	0.00	911.10	0.00	722249.	0.087	1p
2435.0	20485165.	168.19	0.00000	722461.	0.	-0.92	0.00	911.19	0.00	722461.	0.087	1p
2460.0	20679439.	168.21	0.00000	722674.	0.	-0.92	0.00	911.28	0.00	722674.	0.087	1p
2485.0	20873732.	168.23	0.00000	722886.	0.	-0.92	0.00	911.37	0.00	722886.	0.087	1p
2510.0	21068044.	168.26	0.00000	723098.	0.	-0.92	0.00	911.46	0.00	723098.	0.087	1p
2530.0	21223508.	168.27	0.00000	723268.	0.	-0.92	0.00	911.53	0.00	723268.	0.087	1p

SAMPLE 3 INPUT FILE

Sample 3 for Simulator HOLA
- Option 2 used -

3.0000E+06
14.10E+06
0.100E+06

2530.000
0.000
2800.000
1000.000
6.0480E+05
20

300.0	0.1102	4.6E-5	25.0	90.0
30.0	0.1102	4.6E-5	15.0	88.0
30.0	0.1102	4.6E-5	15.0	86.0
30.0	0.1102	4.6E-5	15.0	84.0
30.0	0.1102	4.6E-5	15.0	82.0
30.0	0.1102	4.6E-5	15.0	80.0
30.0	0.1102	4.6E-5	15.0	78.0
30.0	0.1102	4.6E-5	15.0	76.0
30.0	0.1102	4.6E-5	15.0	74.0
30.0	0.1102	4.6E-5	15.0	72.0
30.0	0.1102	4.6E-5	15.0	70.0
30.0	0.1102	4.6E-5	15.0	68.0
30.0	0.1102	4.6E-5	15.0	66.0
30.0	0.1102	4.6E-5	15.0	64.0
30.0	0.1102	4.6E-5	15.0	62.0
30.0	0.1102	4.6E-5	15.0	60.0
150.0	0.1102	4.6E-5	25.0	60.0
10.0	0.1102	4.6E-5	10.0	60.0
1600.0	0.0873	1.5E-5	25.0	60.0
20.0	0.0873	1.5E-5	20.0	60.0

4
0.0 25.00
1000.0 260.00
2000.0 310.00
2500.0 330.00

3
1110.0 10.0E+06 1600.0E+03 5.0E-13
2010.0 13.5E+06 1200.0E+03 8.00E-13
2530.0 15.35E+06 290.0 5.00E-13

SAMPLE 3 HOLA.LOG FILE

It no	0-	Iteration no :	0	Single water to two phase flow at 1285.00 m depth
It no	1-	Iteration no :	1	Single water to two phase flow at 1285.00 m depth
It no	2-	Iteration no :	2	Single water to two phase flow at 1285.00 m depth

SAMPLE 3 HOLA.LOG FILE

		Iteration no : 3	
It no	3-	Single water to two phase flow at 1285.00 m depth	
		Iteration no : 4	
It no	4-	Single water to two phase flow at 1285.00 m depth	
		Iteration no : 5	
It no	5-	Single water to two phase flow at 1285.00 m depth	
		Iteration no : 6	
It no	6-	Single water to two phase flow at 1285.00 m depth	
		Iteration no : 7	
It no	7-	Single water to two phase flow at 1285.00 m depth	
		Iteration no : 8	
It no	8-	Single water to two phase flow at 1285.00 m depth	
		Iteration no : 9	
It no	9-	Single water to two phase flow at 1285.00 m depth	
		Iteration no : 10	
It no	10-	Single water to two phase flow at 1285.00 m depth	
		Iteration no : 11	
It no	11-	Single water to two phase flow at 1285.00 m depth	
		Iteration no : 12	
It no	12-	Single water to two phase flow at 1285.00 m depth	
		Iteration no : 13	
It no	13-	Single water to two phase flow at 1285.00 m depth	
		Iteration no : 14	
It no	14-	Single water to two phase flow at 1285.00 m depth	
		Iteration no : 15	
It no	15-	Single water to two phase flow at 1285.00 m depth	

SAMPLE 3 HOLA.ITER FILE

	P required (bars)	Max Error (bars)	Step size (bars)	Pbott Max (bars)	Pbott min (bars)
	30.0000	1.0000	0.0200	153.4800	30.0000
It no	P bottom (bars)	P top (bars)	Difference (bars)	Q top (kg/s)	H top (kJ/kg)
0	141.0000	31.4348	1.4348	36.906	1448.689
1	140.9800	31.4059	1.4059	36.939	1448.576
2	140.9600	31.3769	1.3769	36.973	1448.462
3	140.9400	31.3478	1.3478	37.006	1448.349
4	140.9200	31.3188	1.3188	37.040	1448.235
5	140.9000	31.2897	1.2897	37.074	1448.121
6	140.8800	31.2605	1.2605	37.107	1448.008
7	140.8600	31.2314	1.2314	37.141	1447.894
8	140.8400	31.2022	1.2022	37.174	1447.780
9	140.8200	31.1729	1.1729	37.208	1447.666
10	140.8000	31.1437	1.1437	37.242	1447.552
11	140.7800	31.1144	1.1144	37.275	1447.438
12	140.7600	31.0851	1.0851	37.309	1447.323
13	140.7400	31.0557	1.0557	37.342	1447.209
14	140.7200	31.0264	1.0264	37.376	1447.094
15	140.7000	30.9970	0.9970	37.410	1446.980

SAMPLE 3 OUTPUT FILE

HOLA - MODEL RESULTS

Sample 3 for Simulator HOLA
- Option 2 used -

Wellhead pressure (bar abs.) : 31.00
 Wellhead temperature (C) : 235.66
 Wellhead dryness : 0.241
 Wellhead enthalpy (kJ/kg) : 1446.98
 Wellhead total flow (kg/s) : 37.41

Feedzone no:	Depth (m)	Flow (kg/s)	Enthalpy (kJ/kg)	Res.Pres (Bar)	Satur.	Prod. Ind. (m ³)
1	1110.0	10.5567	1600.0	100.000	0.68	0.500000E-12
2	2010.0	16.7768	1200.0	135.000	0.00	0.800000E-12
3	2530.0	10.0761	1284.4	153.500	0.00	0.500000E-12

Depth (m)	Press (Pa)	Temp (C)	Dryness	Hw (J/kg)	Hs (J/kg)	Vw (m/s)	Vs (m/s)	Dw (kg/m ³)	Ds (kg/m ³)	H_t (J/kg)	Rad (m)	Reg
0.0	3099696.	235.66	0.24084	1016960.	2802465.	14.31	16.26	819.65	15.51	1446980.	0.110	Sl
25.0	3130763.	236.22	0.23985	1019604.	2802469.	14.13	16.05	818.88	15.66	1447233.	0.110	Bu
50.0	3161868.	236.77	0.23887	1022233.	2802468.	13.96	15.84	818.11	15.82	1447485.	0.110	Bu
75.0	3193015.	237.32	0.23790	1024848.	2802461.	13.80	15.64	817.35	15.98	1447737.	0.110	Bu
100.0	3224207.	237.87	0.23692	1027451.	2802448.	13.63	15.43	816.59	16.14	1447989.	0.110	Bu
125.0	3255450.	238.41	0.23595	1030040.	2802429.	13.47	15.24	815.83	16.29	1448241.	0.110	Bu
150.0	3286747.	238.96	0.23499	1032617.	2802404.	13.31	15.05	815.08	16.45	1448493.	0.110	Bu
175.0	3318103.	239.49	0.23402	1035183.	2802374.	13.15	14.86	814.33	16.61	1448744.	0.110	Bu
200.0	3349522.	240.03	0.23306	1037737.	2802339.	13.00	14.67	813.57	16.77	1448996.	0.110	Bu
225.0	3381007.	240.56	0.23210	1040282.	2802297.	12.85	14.49	812.82	16.93	1449247.	0.110	Bu
250.0	3412564.	241.09	0.23114	1042816.	2802251.	12.70	14.31	812.07	17.09	1449498.	0.110	Bu
275.0	3444194.	241.62	0.23019	1045340.	2802199.	12.55	14.13	811.33	17.25	1449749.	0.110	Bu
300.0	3475904.	242.14	0.22924	1047855.	2802141.	12.41	13.96	810.58	17.41	1450000.	0.110	Bu

315.0	3494969.	242.46	0.22866	1049360.	2802104.	12.32	13.86	810.14	17.51	1450150.	0.110	Bu
330.0	3514057.	242.77	0.22809	1050862.	2802065.	12.24	13.75	809.69	17.61	1450299.	0.110	Bu
345.0	3533177.	243.08	0.22752	1052360.	2802024.	12.15	13.65	809.24	17.70	1450449.	0.110	Bu
360.0	3552308.	243.39	0.22695	1053854.	2801981.	12.07	13.55	808.80	17.80	1450598.	0.110	Bu
375.0	3571472.	243.70	0.22638	1055345.	2801937.	11.99	13.46	808.35	17.90	1450747.	0.110	Bu
390.0	3590633.	244.01	0.22582	1056831.	2801890.	11.91	13.36	807.91	18.00	1450895.	0.110	Bu
405.0	3609829.	244.32	0.22525	1058314.	2801842.	11.83	13.26	807.47	18.09	1451044.	0.110	Bu
420.0	3629008.	244.63	0.22468	1059791.	2801792.	11.75	13.17	807.03	18.19	1451192.	0.110	Bu
435.0	3648223.	244.93	0.22412	1061265.	2801740.	11.67	13.07	806.58	18.29	1451340.	0.110	Bu
450.0	3667407.	245.24	0.22356	1062732.	2801686.	11.59	12.98	806.15	18.39	1451487.	0.110	Bu
465.0	3686628.	245.54	0.22299	1064197.	2801631.	11.51	12.89	805.71	18.49	1451634.	0.110	Bu
480.0	3705804.	245.84	0.22243	1065653.	2801574.	11.43	12.80	805.27	18.58	1451780.	0.110	Bu
495.0	3725017.	246.15	0.22187	1067107.	2801515.	11.36	12.71	804.83	18.68	1451926.	0.110	Bu
510.0	3744170.	246.45	0.22132	1068552.	2801454.	11.28	12.62	804.40	18.78	1452071.	0.110	Bu
525.0	3763361.	246.74	0.22076	1069994.	2801392.	11.21	12.53	803.96	18.88	1452215.	0.110	Bu
540.0	3782476.	247.04	0.22020	1071427.	2801329.	11.14	12.44	803.53	18.98	1452359.	0.110	Bu
555.0	3801630.	247.34	0.21965	1072857.	2801263.	11.06	12.35	803.10	19.08	1452502.	0.110	Bu
570.0	3820691.	247.63	0.21910	1074276.	2801196.	10.99	12.27	802.67	19.17	1452644.	0.110	Bu
585.0	3839792.	247.92	0.21855	1075693.	2801128.	10.92	12.19	802.24	19.27	1452786.	0.110	Bu
600.0	3858784.	248.21	0.21800	1077097.	2801058.	10.85	12.10	801.82	19.37	1452926.	0.110	Bu
615.0	3877815.	248.50	0.21746	1078500.	2800987.	10.78	12.02	801.39	19.47	1453066.	0.110	Bu
630.0	3896721.	248.79	0.21691	1079889.	2800915.	10.71	11.94	800.97	19.57	1453204.	0.110	Bu
645.0	3915666.	249.07	0.21637	1081277.	2800841.	10.65	11.86	800.55	19.66	1453342.	0.110	Bu
660.0	3934469.	249.36	0.21583	1082650.	2800765.	10.58	11.78	800.13	19.76	1453478.	0.110	Bu
675.0	3953310.	249.64	0.21530	1084022.	2800689.	10.51	11.70	799.71	19.86	1453614.	0.110	Bu
690.0	3971991.	249.92	0.21476	1085377.	2800611.	10.45	11.63	799.30	19.95	1453748.	0.110	Bu
705.0	3990711.	250.19	0.21423	1086732.	2800532.	10.38	11.55	798.89	20.05	1453882.	0.110	Bu
720.0	4009253.	250.47	0.21370	1088069.	2800452.	10.32	11.48	798.48	20.15	1454013.	0.110	Bu
735.0	4027833.	250.74	0.21318	1089405.	2800371.	10.26	11.40	798.07	20.24	1454145.	0.110	Bu
750.0	4046216.	251.01	0.21266	1090724.	2800289.	10.20	11.33	797.67	20.34	1454274.	0.110	Bu
775.0	4076939.	251.46	0.21179	1092918.	2800149.	10.09	11.21	797.00	20.50	1454490.	0.110	Bu
800.0	4107770.	251.91	0.21092	1095109.	2800005.	9.99	11.09	796.32	20.66	1454706.	0.110	Bu
825.0	4138711.	252.36	0.21005	1097298.	2799856.	9.89	10.97	795.65	20.82	1454921.	0.110	Bu
850.0	4169765.	252.81	0.20918	1099484.	2799704.	9.80	10.86	794.98	20.98	1455137.	0.110	Bu
875.0	4200935.	253.25	0.20831	1101668.	2799547.	9.70	10.74	794.31	21.14	1455353.	0.110	Bu
900.0	4232225.	253.70	0.20744	1103849.	2799385.	9.60	10.63	793.63	21.30	1455568.	0.110	Bu
910.0	4244774.	253.88	0.20709	1104722.	2799319.	9.56	10.59	793.36	21.37	1455654.	0.110	Bu
935.0	4297035.	254.61	0.20552	1108336.	2799039.	15.13	16.55	792.25	21.64	1455801.	0.087	Bu
960.0	4338496.	255.19	0.20433	1111183.	2798810.	14.93	16.32	791.36	21.86	1456020.	0.087	Bu
985.0	4380009.	255.77	0.20315	1114017.	2798574.	14.73	16.10	790.48	22.08	1456239.	0.087	Bu
1010.0	4473568.	257.05	0.20037	1120342.	2798020.	3.24	27.15	788.51	22.57	1456496.	0.087	Bu
1035.0	4641400.	259.30	0.19528	1131482.	2796950.	3.22	25.92	785.02	23.45	1456717.	0.087	Bu
1060.0	4811969.	261.53	0.19017	1142547.	2795768.	3.19	24.75	781.52	24.35	1456937.	0.087	Bu
1085.0	4985228.	263.73	0.18503	1153541.	2794474.	3.17	23.63	778.01	25.28	1457156.	0.087	Bu

1110.0	5161106.	265.90	0.17985	1164463.	2793069.	3.15	22.55	774.50	26.22	1457374.	0.087	Bu
1110.0	5161106.	265.90	0.03555	1164463.	2793069.	2.32	3.83	774.50	26.22	1222367.	0.087	Bu
1135.0	5294781.	267.51	0.03086	1172613.	2791943.	2.29	3.34	771.86	26.95	1222580.	0.087	Bu
1160.0	5423259.	269.04	0.02637	1180330.	2790813.	2.25	2.91	769.35	27.64	1222792.	0.087	Bu
1185.0	5549470.	270.51	0.02197	1187805.	2789661.	2.15	2.59	766.91	28.33	1223005.	0.087	Bu
1210.0	5676192.	271.95	0.01758	1195208.	2788462.	2.05	2.28	764.47	29.03	1223218.	0.087	Bu
1235.0	5803616.	273.39	0.01317	1202555.	2787216.	1.93	1.99	762.04	29.73	1223430.	0.087	Bu
1260.0	5932366.	274.81	0.00873	1209882.	2785916.	1.80	1.72	759.61	30.45	1223643.	0.087	Bu
1285.0	6077794.	276.39	0.00000	1223855.	2784400.	1.49	1.49	754.77	31.26	1223856.	0.087	Bu
1310.0	6239615.	277.56	0.00000	1224067.	0.	1.49	0.00	754.93	0.00	1224067.	0.087	1p
1335.0	6401469.	277.61	0.00000	1224280.	0.	1.49	0.00	755.09	0.00	1224280.	0.087	1p
1360.0	6563356.	277.67	0.00000	1224492.	0.	1.48	0.00	755.24	0.00	1224492.	0.087	1p
1385.0	6725275.	277.73	0.00000	1224704.	0.	1.48	0.00	755.40	0.00	1224704.	0.087	1p
1410.0	6887228.	277.78	0.00000	1224916.	0.	1.48	0.00	755.56	0.00	1224916.	0.087	1p
1435.0	7049213.	277.84	0.00000	1225128.	0.	1.48	0.00	755.71	0.00	1225128.	0.087	1p
1460.0	7211232.	277.89	0.00000	1225341.	0.	1.48	0.00	755.87	0.00	1225341.	0.087	1p
1485.0	7373283.	277.95	0.00000	1225553.	0.	1.48	0.00	756.02	0.00	1225553.	0.087	1p
1510.0	7535366.	278.01	0.00000	1225765.	0.	1.48	0.00	756.18	0.00	1225765.	0.087	1p
1535.0	7697483.	278.06	0.00000	1225977.	0.	1.48	0.00	756.33	0.00	1225977.	0.087	1p
1560.0	7859631.	278.12	0.00000	1226190.	0.	1.48	0.00	756.49	0.00	1226190.	0.087	1p
1585.0	8021813.	278.17	0.00000	1226402.	0.	1.48	0.00	756.64	0.00	1226402.	0.087	1p
1610.0	8184027.	278.23	0.00000	1226614.	0.	1.48	0.00	756.79	0.00	1226614.	0.087	1p
1635.0	8346273.	278.28	0.00000	1226826.	0.	1.48	0.00	756.95	0.00	1226826.	0.087	1p
1660.0	8508551.	278.34	0.00000	1227039.	0.	1.48	0.00	757.10	0.00	1227039.	0.087	1p
1685.0	8670862.	278.39	0.00000	1227251.	0.	1.48	0.00	757.26	0.00	1227251.	0.087	1p
1710.0	8833205.	278.45	0.00000	1227463.	0.	1.48	0.00	757.41	0.00	1227463.	0.087	1p
1735.0	8995581.	278.51	0.00000	1227675.	0.	1.48	0.00	757.56	0.00	1227675.	0.087	1p
1760.0	9157989.	278.56	0.00000	1227887.	0.	1.48	0.00	757.71	0.00	1227887.	0.087	1p
1785.0	9320428.	278.62	0.00000	1228100.	0.	1.48	0.00	757.87	0.00	1228100.	0.087	1p
1810.0	9482900.	278.67	0.00000	1228312.	0.	1.48	0.00	758.02	0.00	1228312.	0.087	1p
1835.0	9645404.	278.73	0.00000	1228524.	0.	1.48	0.00	758.17	0.00	1228524.	0.087	1p
1860.0	9807940.	278.78	0.00000	1228736.	0.	1.48	0.00	758.32	0.00	1228736.	0.087	1p
1885.0	9970508.	278.84	0.00000	1228949.	0.	1.48	0.00	758.47	0.00	1228949.	0.087	1p
1910.0	10133107.	278.89	0.00000	1229161.	0.	1.48	0.00	758.63	0.00	1229161.	0.087	1p
1935.0	10295739.	278.95	0.00000	1229373.	0.	1.48	0.00	758.78	0.00	1229373.	0.087	1p
1960.0	10458402.	279.00	0.00000	1229585.	0.	1.48	0.00	758.93	0.00	1229585.	0.087	1p
1985.0	10621098.	279.06	0.00000	1229798.	0.	1.48	0.00	759.08	0.00	1229798.	0.087	1p
2010.0	10783824.	279.11	0.00000	1230010.	0.	1.48	0.00	759.23	0.00	1230010.	0.087	1p
2010.0	10783824.	288.62	0.00000	1279976.	0.	0.57	0.00	741.12	0.00	1279976.	0.087	1p
2035.0	10941481.	288.68	0.00000	1280189.	0.	0.57	0.00	741.28	0.00	1280189.	0.087	1p
2060.0	11099172.	288.74	0.00000	1280401.	0.	0.57	0.00	741.44	0.00	1280401.	0.087	1p
2085.0	11256896.	288.80	0.00000	1280613.	0.	0.57	0.00	741.60	0.00	1280613.	0.087	1p
2110.0	11414654.	288.86	0.00000	1280825.	0.	0.57	0.00	741.75	0.00	1280825.	0.087	1p
2135.0	11572446.	288.92	0.00000	1281037.	0.	0.57	0.00	741.91	0.00	1281037.	0.087	1p

2160.0	11730272.	288.98	0.00000	1281250.	0.	0.57	0.00	742.07	0.00	1281250.	0.087	1p
2185.0	11888131.	289.04	0.00000	1281462.	0.	0.57	0.00	742.23	0.00	1281462.	0.087	1p
2210.0	12046024.	289.10	0.00000	1281674.	0.	0.57	0.00	742.39	0.00	1281674.	0.087	1p
2235.0	12203951.	289.16	0.00000	1281886.	0.	0.57	0.00	742.55	0.00	1281886.	0.087	1p
2260.0	12361911.	289.22	0.00000	1282099.	0.	0.57	0.00	742.71	0.00	1282099.	0.087	1p
2285.0	12519904.	289.28	0.00000	1282311.	0.	0.57	0.00	742.86	0.00	1282311.	0.087	1p
2310.0	12677931.	289.34	0.00000	1282523.	0.	0.57	0.00	743.02	0.00	1282523.	0.087	1p
2335.0	12835991.	289.40	0.00000	1282735.	0.	0.57	0.00	743.18	0.00	1282735.	0.087	1p
2360.0	12994085.	289.46	0.00000	1282947.	0.	0.57	0.00	743.33	0.00	1282947.	0.087	1p
2385.0	13152212.	289.52	0.00000	1283160.	0.	0.57	0.00	743.49	0.00	1283160.	0.087	1p
2410.0	13310372.	289.57	0.00000	1283372.	0.	0.57	0.00	743.65	0.00	1283372.	0.087	1p
2435.0	13468565.	289.63	0.00000	1283584.	0.	0.57	0.00	743.80	0.00	1283584.	0.087	1p
2460.0	13626791.	289.69	0.00000	1283796.	0.	0.57	0.00	743.96	0.00	1283796.	0.087	1p
2485.0	13785050.	289.75	0.00000	1284008.	0.	0.57	0.00	744.12	0.00	1284008.	0.087	1p
2510.0	13943342.	289.81	0.00000	1284221.	0.	0.57	0.00	744.27	0.00	1284221.	0.087	1p
2530.0	14070000.	289.86	0.00000	1284390.	2802465.	0.57	16.23	744.39	15.52	1284390.	0.087	1p
2530.0	14070000.	289.86	0.00000	1284390.	2802465.	0.57	16.23	744.39	15.52	1284390.	0.087	1p

LAWRENCE BERKELEY LABORATORY
UNIVERSITY OF CALIFORNIA
INFORMATION RESOURCES DEPARTMENT
BERKELEY, CALIFORNIA 94720