

Lawrence Berkeley National Laboratory

Recent Work

Title

MULTI-WIRE PROPORTIONAL CHAMBERS FOR LOW DOSE X-RADIOGRAPHY

Permalink

<https://escholarship.org/uc/item/09k3q1dc>

Authors

Kaufman, Leon
Perez-Mendez, Victor
Sperinde, John
et al.

Publication Date

1971-04-01

Submitted to
American Journal of
Roentology, Radium Therapy
and Nuclear Medicine

L. Kaufman

UCRL-20653 c. 2
Preprint

TWO-WEEK LOAN COPY

*This is a Library Circulating Copy
which may be borrowed for two weeks.
For a personal retention copy, call
Tech. Info. Division, Ext. 5545*

**RECEIVED
LAWRENCE
RADIATION LABORATORY**

**BRAND AND
DOCUMENTS SECTION**

**MULTI-WIRE PROPORTIONAL CHAMBERS FOR
LOW DOSE X-RADIOGRAPHY**

Leon Kaufman, Victor Perez-Mendez,
John Sperinde, and Gerald Stoker

April 1971

AEC Contract No. W-7405-eng-48

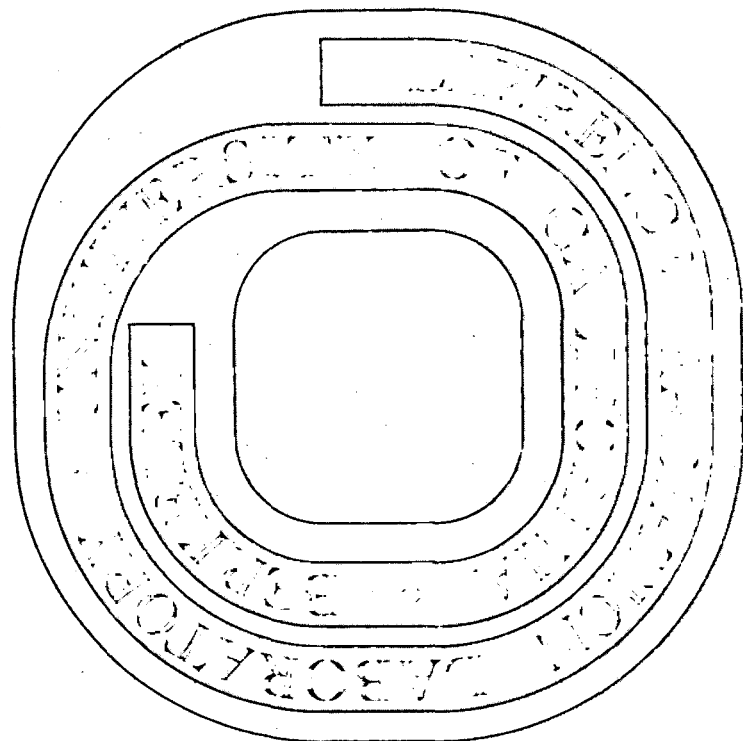

DISCLAIMER

This document was prepared as an account of work sponsored by the United States Government. While this document is believed to contain correct information, neither the United States Government nor any agency thereof, nor the Regents of the University of California, nor any of their employees, makes any warranty, express or implied, or assumes any legal responsibility for the accuracy, completeness, or usefulness of any information, apparatus, product, or process disclosed, or represents that its use would not infringe privately owned rights. Reference herein to any specific commercial product, process, or service by its trade name, trademark, manufacturer, or otherwise, does not necessarily constitute or imply its endorsement, recommendation, or favoring by the United States Government or any agency thereof, or the Regents of the University of California. The views and opinions of authors expressed herein do not necessarily state or reflect those of the United States Government or any agency thereof or the Regents of the University of California.

MULTI-WIRE PROPORTIONAL CHAMBERS FOR LOW DOSE X-RADIOGRAPHY

Leon Kaufman
University of California, San Francisco

Victor Perez-Mendez
University of California, San Francisco and
Lawrence Radiation Laboratory, Berkeley

John Sperinde and Gerald Stoker
Lawrence Radiation Laboratory, Berkeley

April 1971

ABSTRACT

Xenon-filled multi-wire proportional chambers have a high detection efficiency for x-rays commonly used in diagnostic radiology, and through electronic amplification every detected event can be made visible on a final picture. Since the image is obtainable from electrical signals, these devices also afford the opportunity to obtain digital data. We present here the results obtained with a $20 \times 20 \text{ cm}^2$ wire-chamber filled with a mixture of 94.5% xenon, 5% CO_2 , and 0.5% Freon 13B-1. The spatial resolution of the chamber was of the order of 1 mm and the detection efficiency varied between 97% and 2.5% in the x-ray energy range from 5 keV to 100 keV.

INTRODUCTION

For the detection of x-rays, xenon-filled multi-wire proportional chambers offer the capability of recording large area images with high efficiency. Since the signals are electrical, digitized information is readily available and can be processed by computer techniques. Although the ultimate resolution of these chambers is inferior to that of film, the comparison of picture quality is not too unfavorable, since factors other than film resolution limit the performance of more conventional x-ray systems, i.e. focal spot size, geometry, small angle scattering, subject movement, etc. Thus, for studies where very high resolution is not necessary, use of these chambers can become advantageous. Since the chambers operate in the proportional mode, they also yield the energy of the detected photon with spectral discrimination of the order of 10% FWHM; thus, they can be used for the imaging of characteristic radiation, or to select a narrow band of x-ray energies from a wide range output of standard tube, so that the energy and contrast can be matched to the study of interest.

A. Multi-Wire Proportional Chamber.

The chamber consists of three wire planes with an active area of $20 \times 20 \text{ cm}^2$ thickness. The two outside planes have their wires at 90 degrees to each other and are made of $127 \mu\text{m}$ gold-coated molybdenum wire, stretched on a 1 cm thick frame of Nema G-10 fiberglass epoxy with a pitch of 24 wires per inch. The ends of the wires are soldered to a printed circuit board with its terminals outside

of the frame. Each wire is then connected to a common ground through a 200 k Ω resistor. The central plane consists of 20 μ m gold-coated tungsten wires with the ends soldered to a copper bar and a pitch of 16 wires per inch. A 13 μ m aluminized mylar window seals the active volume of the chamber on the face through which the x-rays arrive, and a 130 μ m aluminized mylar window seals the back face of the chamber. For high detection efficiency of x-rays we chose a gas filling of xenon in a mixture that consisted of 94.5% xenon, 5% CO₂, and 0.5% Freon 13B-1. Figure 1 shows a schematic of the wire chamber assembly.

The principle of operation is as follows: An x-ray photon reaching the active volume of the chamber has a high probability of converting its energy to an electron through the photoelectric effect. The electron will have an energy that will be the energy of the x-ray minus its binding energy in xenon. This energy will then be deposited within a small region mostly in the form of ionization. Due to the electric field between the gaps, the secondary electrons will drift towards the anode wires and will undergo multiplication in a small region surrounding the wires, producing a voltage pulse on them. Simultaneously, an induced pulse of the opposite polarity will be generated on the cathode wires by the initial motion of the positive ions.

B. Image Read-out

The coordinates of an ionizing event are determined by use of an electromagnetic delay line. ⁽¹⁾ These delay lines consist of

a solenoidal winding on a plastic core which forms an inductance. A distributive capacitance is formed by copper strips as shown in fig. 2. The inherent dispersion in lines of this type is compensated ^(2,3) by the floating patch technique. Delays of 5 to 20 nsec per millimeter are easy to obtain, and can be varied to match the problem at hand. The signals from the chamber are coupled capacitatively to the delay lines by placing the delay lines in close proximity to the printed circuit boards.

A signal that indicates the occurrence of an ionizing event is obtained by reading out the central plane through an RC network with a time constant of 500 nsec. This signal is processed by the technique of differentiation and zero crossing and used to start two time-to-height converters. Similarly processed signals are obtained from the delay lines and used to stop the converters, one for the X coordinate and one for the Y coordinate. Figure 3 shows the schematics of this technique and typical signals obtained from the center plane and delay line.

C. Display System

Image display was achieved by using the outputs from the time-to-height converters to drive the XY deflection plates of a CRT, while simultaneously a Z unblank signal was applied. A Tektronix 536 scope was used for display purposes. Since the delay line used had a total length of 1 μ sec, a pile-up rejector was used to eliminate multiple events occurring in time intervals shorter than this. The individual image points on the CRT were integrated by a Polaroid camera left with the shutter open.

RESULTS

The chamber efficiency and sensitivity (in events/cm² for 1 roentgen) were calculated and are shown in Figure 4. Measurements to corroborate these calculations were performed at 22 keV and 60 keV.

The system in its present configuration could be operated at a rate of 10⁵ events/sec., with a rejection rate of 10% due to pile-up.

For a discussion of spatial resolution, the following considerations are of importance: Figure 5a shows the electric field configuration at the multiplication wires. It can be seen that if an ionizing event occurs somewhere between two wires it will drift towards one of those wires and will produce a signal at that point. Thus, position information will be quantized in a direction perpendicular to the wire direction, and the resolution cannot be better than the wire spacing. In a direction parallel to the multiplication wires, the signal will be produced at the same location where the conversion has occurred, and no quantization should be evident. We have shown ⁽¹⁾ that the induced signals on the outside planes are spread over many wires, and since the delay-line picks the center of gravity of that signal, we can easily interpolate to distances smaller than the wire spacing. Figure 5-b shows the results obtained on a chamber with a wire pitch of 12 wires per inch. While the resolution in the direction perpendicular to the multiplication wires is just given by the wire spacing, in the direction parallel to these wires the resolution is of the order of 200 μm. By building

the central multiplication plane with its wires at 45 degrees to the wires on the outside planes we can symmetrize the XY response of the chamber, in this case obtaining a resolution of about 1.1 mm along the X and Y directions. We determined the Modulation Transfer Function (MTF) of the chamber along the X and Y directions by recording the data from three resolution grid patterns consisting of lead slats 4, 2, and 1 mm wide spaced by 4, 2, and 1 mm distances respectively. Since the object contrast in this case is 100%, the value of the MTF is given by the measured image contrast. For these tests we used a Cd ¹⁰⁹ source 3 mm in diameter placed 12 cm above the grid pattern, which was located on the face of the chamber. The MTF was corrected for source size and is shown in Figure 6. Figures 7 and 8 show pictures obtained with this chamber using 5.9 keV and 22 keV sources respectively.

FUTURE DEVELOPMENTS

The spatial resolution of the chamber is limited both by the wire spacing and by the statistics of the amount of information that has been collected. Given the maximum data collection rate of ⁵ 10 events per second in the present configuration, we find that for other than stationary subjects (for which exposure times can be relatively long) the amount of information that one can collect is severely limited by the amount of time that the exposure can be carried through. Future developments with these chambers will be along two directions: (a) The central plane wire spacing will be reduced. (We have already successfully operated with a wire pitch

of 24 wires per inch and we intend to test 48 wires per inch);

(b) Improvements in the timing electronics will allow us to use faster delay lines without sacrificing resolution, thus reducing the pile-up time and consequently increasing the maximum data collection rate.

At this time we feel we have realized a detector that can be useful for specialized applications where either the subject of interest can be immobilized, or where resolution is not of paramount importance, but dosage is. We have also found applications where the ability to measure the energy of the detected x-ray provides a unique method for the construction of cameras that can image the distribution of high-Z elements through fluorescence excitation,⁽⁴⁾ and for applications as transition radiation detectors.⁽⁵⁾

ACKNOWLEDGMENT

This work was supported by the United States Atomic Energy Commission.

REFERENCES

1. R. Grove, K. Lee, V. Perez-Mendez and J. Sperinde, Nuc. Inst. Methods 89, 257 (1970).
2. R. Grove, I. Ko, B. Leskovar, and V. Perez-Mendez, UCRL-20255 (March 1971).
3. R. A. Erickson and H. Sommer, Proc. of the I.R.E. 38, 1036 (1950).
4. L. Kaufman, V. Perez-Mendez and M. R. Powell, "Laminographic Excitation Camera for Thyroid Imaging," UCRL-20229 (December 1970), presented at the Winter Meeting of the Northern California Society of Nuclear Medicine, Stanford, Calif., (Feb. 1971).
5. L. C. L. Yuan, I.E.E.E. Trans. Nucl. Sc. 17, 24 (1970).

FIGURE CAPTIONS

- Figure 1: Wire chamber assembly. The wires are stretched on Nema G-10 fiber-glass epoxy frames and soldered to printed circuit boards. The external planes are made of 127 μm wires with a pitch of 24 wires per inch. The center plane is made of 20 μm wires with a pitch of 16 wires per inch.
- Figure 2: Delay line construction. The solenoidal winding provides an inductance. A distributed capacitance is provided by the eight copper strips. The floating metal strips compensate for dispersion.
- Figure 3: Schematic of the readout technique. The delay lines are placed on the printed circuit boards. A start signal is obtained from the center plane, and stop signals are obtained from the delay lines. These signals (shown in the insert photographs) are amplified and processed by the technique of differentiation and zero crossing, and are used to drive two time-to-height converters.
- Figure 4: (a) Shows the calculated efficiency of the chamber; and (b) shows the sensitivity. These values were corroborated by measurements at 22 keV and 60 keV.
- Figure 5: (a) Electric field configuration at the wires; (b) results of spatial location accuracy measurements along coordinates perpendicular and parallel to the central wires.
- Figure 6: MTF, corrected for source size, along the X and directions.
- Figure 7: X-ray transmission pictures of philodendron leaves taken with a 0.03 mR exposure at 5.9 keV.
- Figure 8: X-ray transmission pictures taken with exposures of: (a) 0.015 mR; (b) 0.030 mR; (c) 0.045 mR; and (d) 0.038 mR at 22 keV.

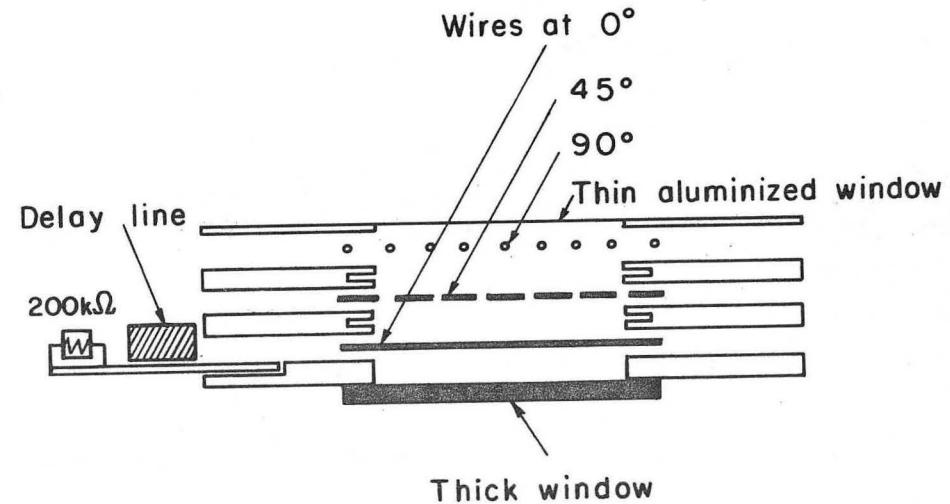

XBL711 - 2728

Fig. 1

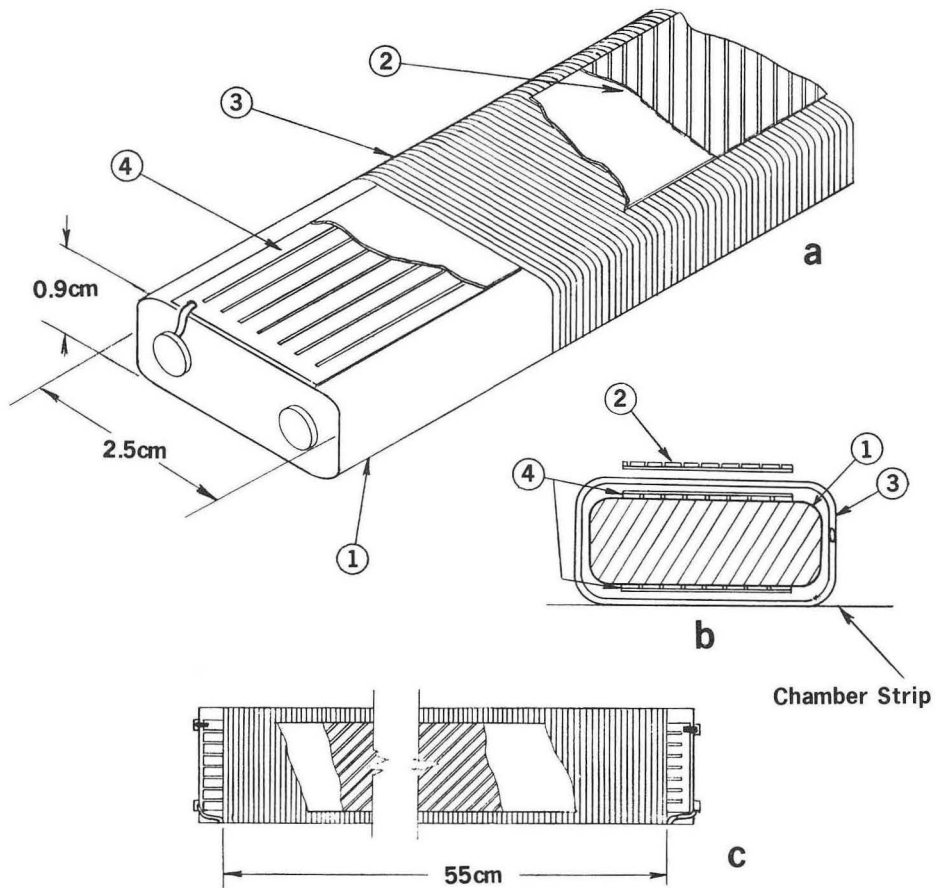

- ① Plastic Core
- ② Floating Metal Strips On Mylar Base: Strips = 1.8mm Wide; Gaps = 0.3mm Wide; Mylar = 25 Microns Thick
- ③ Winding = #30 Formvar Wire
- ④ 8 Copper Strips On Mylar Base: Strips = 1.8mm Wide; Gaps = 0.3mm Wide; Mylar = 25 Microns Thick

XBL 714-679

Fig. 2

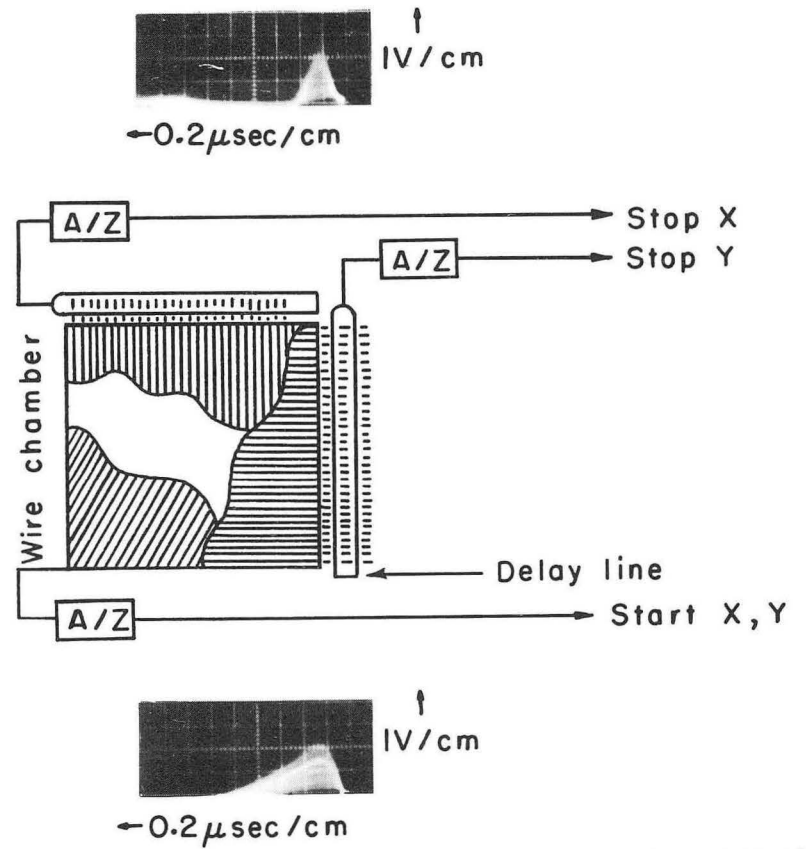

XBB 711-365

Fig. 3

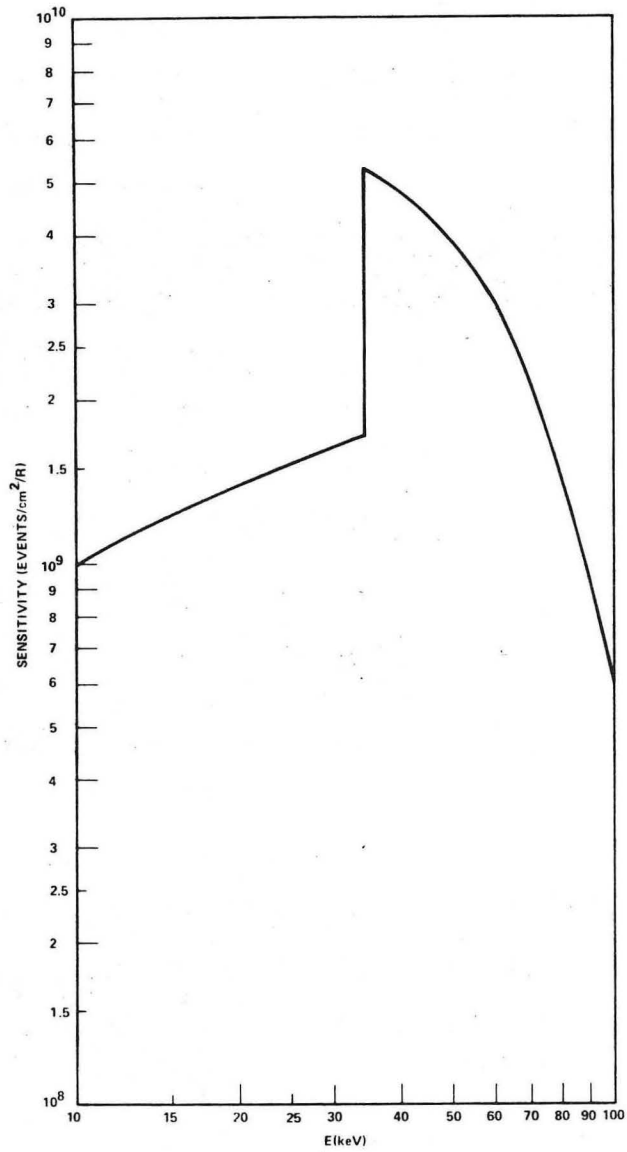

Fig. 4 a

XBL 714-699

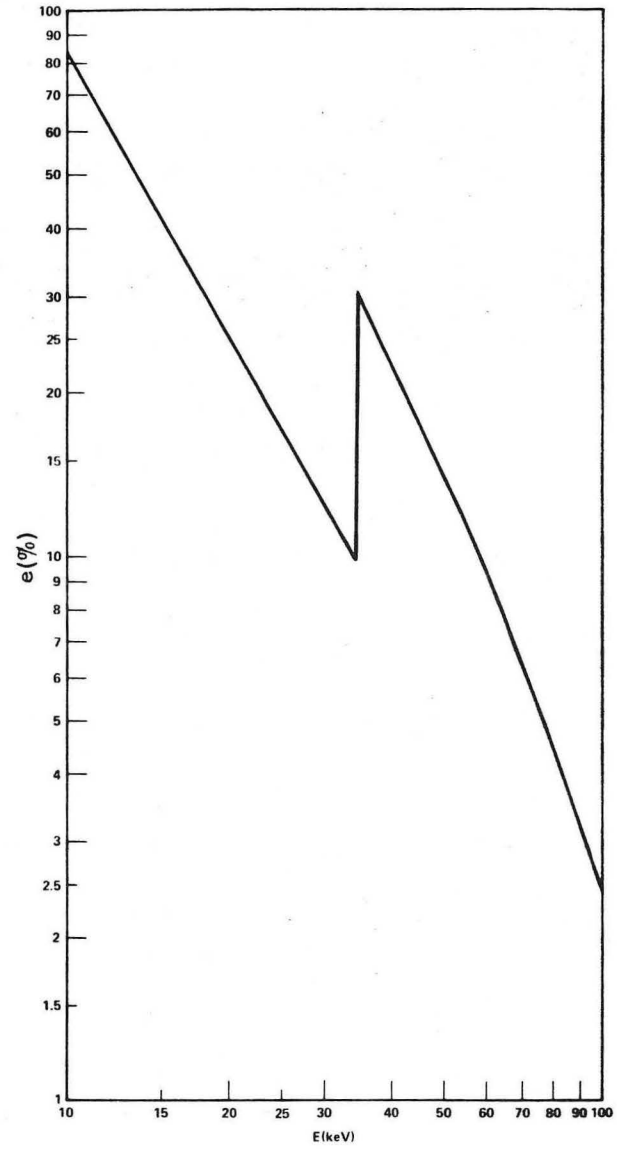

Fig. 4 b

XBL 714-700

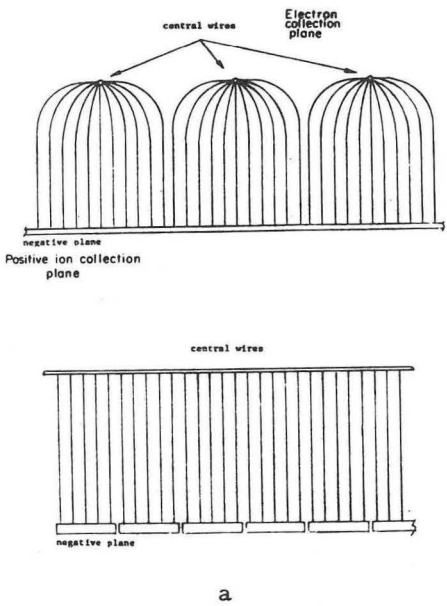

Fig. 5

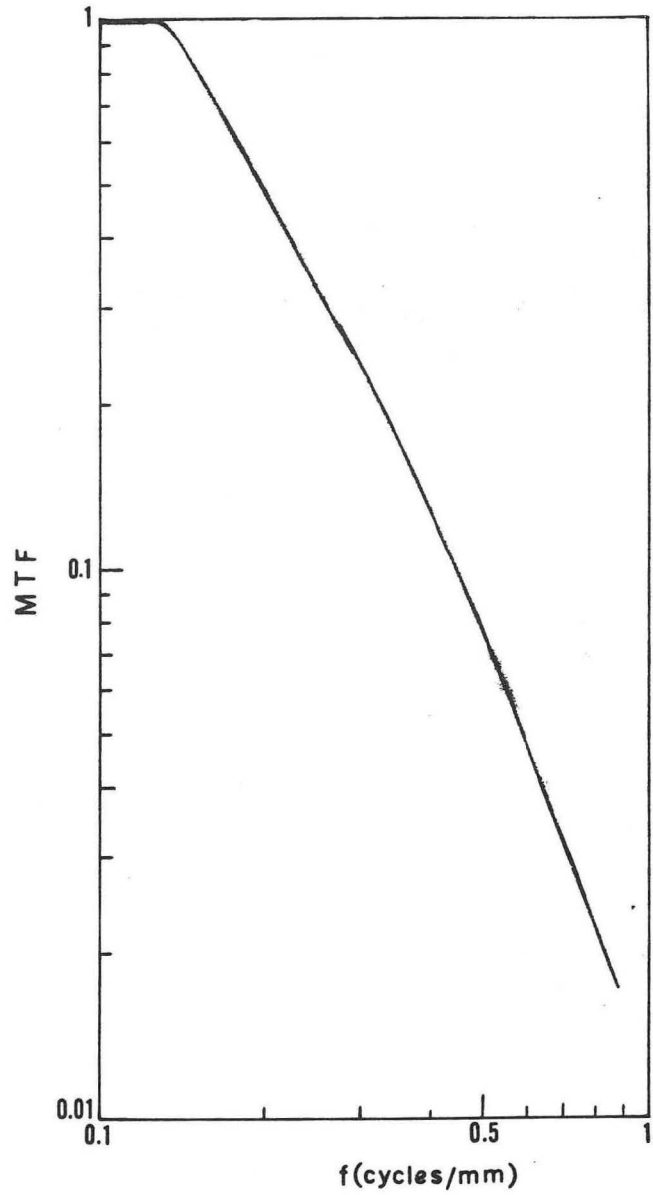
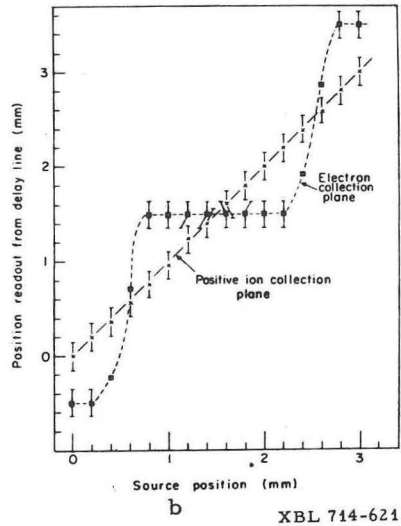
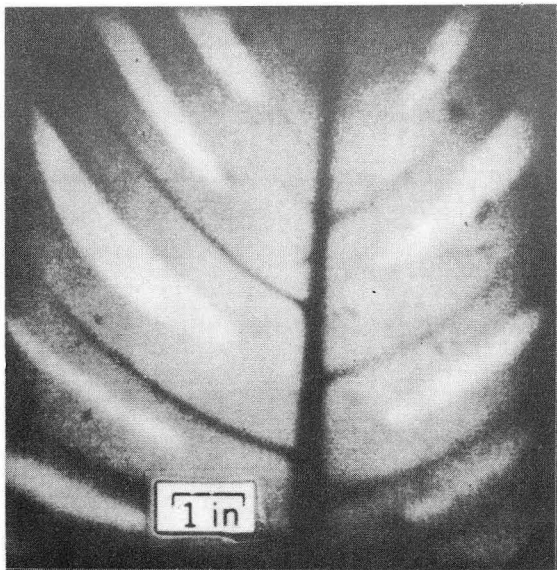
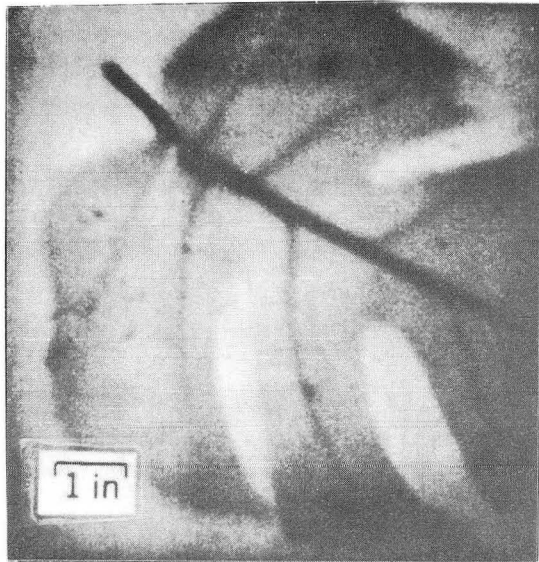
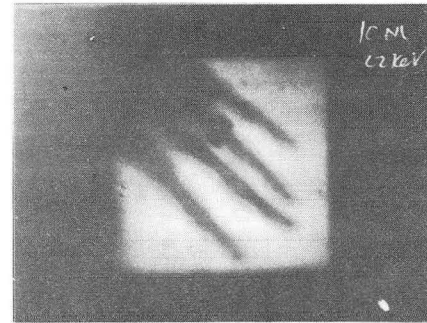

Fig. 6



XBB 713-961A

Fig. 7



a

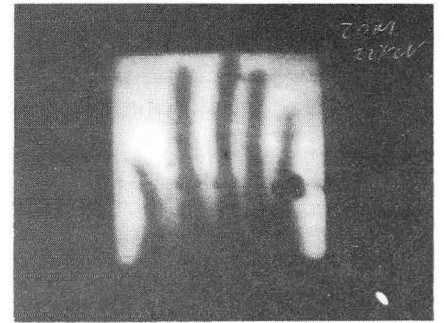

b

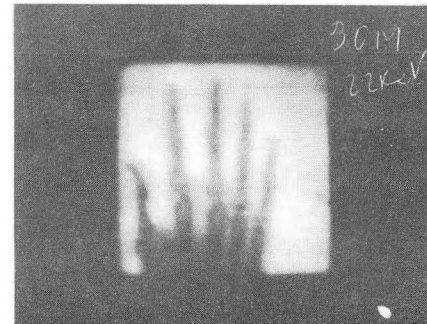

c

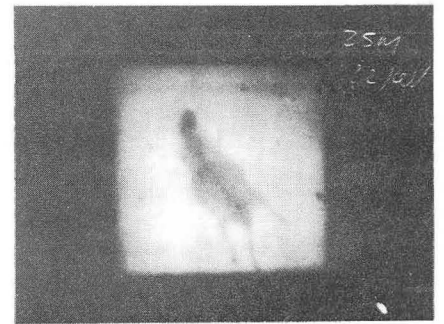

d

XBB 713-884

Fig. 8

LEGAL NOTICE

This report was prepared as an account of work sponsored by the United States Government. Neither the United States nor the United States Atomic Energy Commission, nor any of their employees, nor any of their contractors, subcontractors, or their employees, makes any warranty, express or implied, or assumes any legal liability or responsibility for the accuracy, completeness or usefulness of any information, apparatus, product or process disclosed, or represents that its use would not infringe privately owned rights.

TECHNICAL INFORMATION DIVISION
LAWRENCE RADIATION LABORATORY
UNIVERSITY OF CALIFORNIA
BERKELEY, CALIFORNIA 94720