

Lawrence Berkeley National Laboratory

Recent Work

Title

A DEVICE FOR GENERATING A HIGHLY IONIZED HYDROGEN PLASMA

Permalink

<https://escholarship.org/uc/item/06v3v1x7>

Authors

Wilcox, John M.
DeSilva, Alan W.
Cooper, William S.
et al.

Publication Date

1961-01-12

UNIVERSITY OF
CALIFORNIA

Ernest O. Lawrence

*Radiation
Laboratory*

TWO-WEEK LOAN COPY

*This is a Library Circulating Copy
which may be borrowed for two weeks.
For a personal retention copy, call
Tech. Info. Division, Ext. 5545*

BERKELEY, CALIFORNIA

DISCLAIMER

This document was prepared as an account of work sponsored by the United States Government. While this document is believed to contain correct information, neither the United States Government nor any agency thereof, nor the Regents of the University of California, nor any of their employees, makes any warranty, express or implied, or assumes any legal responsibility for the accuracy, completeness, or usefulness of any information, apparatus, product, or process disclosed, or represents that its use would not infringe privately owned rights. Reference herein to any specific commercial product, process, or service by its trade name, trademark, manufacturer, or otherwise, does not necessarily constitute or imply its endorsement, recommendation, or favoring by the United States Government or any agency thereof, or the Regents of the University of California. The views and opinions of authors expressed herein do not necessarily state or reflect those of the United States Government or any agency thereof or the Regents of the University of California.

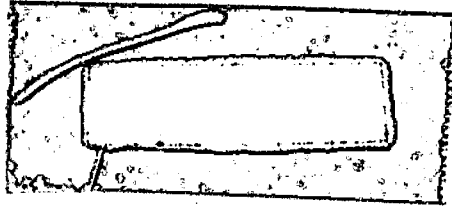

UCRL-9528

UNIVERSITY OF CALIFORNIA

Lawrence Radiation Laboratory
Berkeley, California

Contract No. W-7405-eng-48

A DEVICE FOR GENERATING A HIGHLY
IONIZED HYDROGEN PLASMA

John M. Wilcox, Alan W. DeSilva, William S. Cooper III,
Pierre Pellissier and William R. Baker

January 12, 1961

A DEVICE FOR GENERATING A HIGHLY
IONIZED HYDROGEN PLASMA

John M. Wilcox, Alan W. DeSilva, William S. Cooper III,
Pierre Pellissier and William R. Baker

Lawrence Radiation Laboratory
University of California
Berkeley, California

January 12, 1961

ABSTRACT

A device for generating a highly ionized hydrogen plasma is described. The plasma is contained in a cylindrical tube 86 cm long and 15 cm in diameter immersed in an axial magnetic field of about 15 kgauss. The ion density is 6×10^{15} ions cm^{-3} , the degree of ionization is probably 90 to 100%, and the temperature is about $10,000^{\circ}\text{K}$. The plasma is formed by a switch-on ionizing wave, and then decays in several hundred microseconds by a volume recombination process.

A DEVICE FOR GENERATING A HIGHLY
IONIZED HYDROGEN PLASMA

John M. Wilcox, Alan W. DeSilva, William S. Cooper III,
Pierre Pellissier, and William R. Baker

Lawrence Radiation Laboratory
University of California
Berkeley, California

January 12, 1961

INTRODUCTION

In a device for generating a highly ionized hydrogen plasma, the plasma is contained in a cylindrical tube 86 cm long and 15 cm in diameter immersed in an axial magnetic field of about 15 kgauss. The ion density is 6×10^{15} ions/cm³, the degree of ionization is probably 90 to 100%, and the temperature is about 10,000°K. The plasma is formed by a switch-on ionizing wave, and then decays in several hundred microseconds by a volume recombination process. This device was developed in the course of experiments on Alfvén wave propagation.¹⁻⁴

We first describe the geometry and the method of plasma preparation, next describe the plasma properties and the methods whereby these have been measured, and then describe several of the electrical and mechanical details of the construction of the device. Finally we speculate on the effects of changing the tube dimensions, the magnetic field strength, and the gas pressure and composition.

PLASMA PREPARATION

The geometry employed is shown in Fig. 1. An electrically conducting tube about a meter long and 15 cm in diameter is placed in an axial magnetic field of about 15 kgauss. One end of the tube (the "driving" end) is sealed with a pyrex plate in which is mounted a coaxial molybdenum electrode 5 cm long and 5 cm in diameter. The other end of the tube can be sealed with a pyrex plate, a copper plate, or in almost any way desired. The tube is filled with hydrogen gas at a pressure of 0.1 mm Hg (100 μ) which flows continuously through the system. The ionizing energy is supplied by a lumped-constant pulse line which has been charged to 10 kv. The pulse line is connected through a series resistor R and an ignitron switch to the coaxial molybdenum electrode. The ground side of the pulse line is connected to the tube.

When the high voltage is applied to the coaxial electrode a local electrical breakdown of the gas occurs and a radial current flows. This radial current, together with the axial magnetic field, exerts an azimuthal force on the plasma ($F_{\theta} = j_r \times B_z$), which causes it to rotate and thus develop a back emf which tends to reduce the radial current flow. By a process that is not completely understood the ionization proceeds along the length of the tube. Magnetic-probe measurements have indicated that the width of the ionizing front (i. e., the transition region between a warm highly ionized rotating plasma and an essentially neutral gas) is a few centimeters. This process has been called a "switch-on" ionizing wave, because as the front passes by, an azimuthal component of magnetic field is "switched on."

The progress of the ionizing wave down the tube is observed with radial current probes (Fig. 2). This probe consists of a 1/4-in. -diameter metal button mounted in a hole in the tube wall and insulated from the wall.

A radial current passing from the plasma to the button is returned to the tube through coaxially mounted resistors, and the resulting resistive voltage drop is observed with an oscilloscope. When the ionizing wavefront reaches a radial current probe, we observe a sharply rising signal. The progress of the front down the tube as measured in this way is shown in Fig. 3. The velocity of the wavefront, which in this case is 5 cm/ μ sec, can be changed by varying the experimental conditions.

If the ionizing current continues to flow after the wavefront has reached the far end of the tube, impurity lines characteristic of elements in the pyrex plate are observed spectroscopically. Therefore the ionizing current is shorted out (crowbarred) with the ignitron switch shown in Fig. 1 just as the ionizing wave reaches the end of the tube. This stops the energy flow from the pulse line to the tube, and also abruptly stops the rotation of the plasma, in the same way as a rotating motor or generator will abruptly stop if its armature is shorted out. The kinetic energy of rotation of the plasma is recovered electrically in the form of a reversed current flow, as shown in Fig. 4. In this case the crowbar was applied 20 μ sec after the ionizing current began to flow. The reversed current can be clearly seen. After the crowbar has been applied the current oscillates with a half period of about 10 μ sec. This period is controlled by the inductance of the crowbar circuit, since the rotating kinetic energy can be recovered from the plasma in a time given by the length of the tube divided by the Alfvén velocity. Thus in principle, at least, if external inductances were minimized the current could be brought to zero in less than 2 μ sec, since the Alfvén velocity in this case is about 4.5×10^7 cm/sec.

PLASMA PROPERTIES

The properties of this plasma have been deduced from spectroscopic observations, Alfvén wave-propagation experiments,¹⁻⁴ and magnetic-probe observations.

The plasma density as a function of time has been measured⁵ by observing the Stark broadening of the first three hydrogen Balmer lines, H_{α} , H_{β} , and H_{γ} . The light from a 5-cm-diameter cylinder of plasma in the center of the tube was focused on the entrance slit of a monochromator, as indicated in Fig. 5. The light from the monochromator strikes a photomultiplier tube whose output is displayed on an oscilloscope. With the monochromator set at a particular wavelength on the profile of a spectral line, the light intensity of that wavelength is obtained as a function of time. Six shots are averaged together, because the intensity varies by about 20% from shot to shot. The monochromator is then set to look at another wavelength on the line profile, and the process repeated until the particular spectral line has been covered. Cross plots then give the line profile at any time. A typical result is shown in Fig. 6, which shows the experimental profile of H_{β} at a time 50 μ sec after crowbar. The solid curves are obtained from the theory of Griem, Kolb, and Shen,⁶ who estimate an uncertainty of about 10% in their theoretical profiles. The theoretical variation of the line profile with temperature and density is indicated. Experimental profiles for H_{α} and H_{γ} taken at the same time also agree well with the theory calculated for an ion density of 5×10^{15} ions/cm³ and a temperature of 10,000°K.

The ion density as a function of time is shown in Fig. 7. Because the plasma diffusion times, both along the magnetic field and perpendicular to it, have been estimated to be at least of the order of 10 msec, i. e.,

much longer than the observed decay time, the decay probably takes place by a volume-recombination process. The density measurement by Stark broadening, with the use of our spectroscopic equipment, becomes uncertain below a density of about 10^{15} ions/cm³. The density region below about 10^{13} ions/cm³ could be measured with the microwave interferometry technique; this has not as yet been done.

For measurements early in the decaying plasma, the measured Alfvén wave velocity V_a agrees well with theory if the known magnetic field B and the ion density ρ measured from Stark broadening $\left[V_a = B/(\mu_0 \rho)^{1/2} \right]$ are used. The mass density of neutral atoms present would probably have to be included in the density used in the Alfvén formula, since atom and ion motions are closely coupled owing to the large value of the charge-transfer cross section (see the discussion of this point in Refs. 3 and 4). Thus the agreement of the experimental wave velocity with the theory when the measured ion density is used indicates that the neutral density is small at early times in the decaying plasma, and thus that the plasma is highly ionized. The neutral density has not been measured directly. We may note that the ion density as a function of time in Fig. 7 extrapolates back approximately to 6 or 7×10^{15} ions/cm³, which is the density of neutral atoms present before the gas is ionized.

From the measurement of the attenuation of Alfvén waves it is possible to set a lower limit of about $10,000^\circ\text{K}$ to the temperature of the decaying plasma soon after crowbar, as discussed in Ref. 2.

The radial variation of plasma density has not yet been measured spectroscopically. In the course of the Alfvén wave experiments, however, the radial distribution of the magnetic field associated with the wave was measured with magnetic probes immersed in the plasma. Qualitative agree-

ment between theory and experiment is observed, indicating that there is not a large radial variation in the plasma properties. These observations also indicate that the radial temperature gradient in the decaying plasma may increase with time.

The shape of the experimental line profiles of H_{α} , H_{β} , and H_{γ} agrees well with the theory, which was calculated by assuming a uniform plasma density. This indicates that the plasma observed with the monochromator is fairly homogeneous. Magnetic probes with a sensitivity of 1 gauss immersed in the plasma do not "see" any noise signals from the decaying plasma, which suggests that the amount of magnetic turbulence is very small.

The amount of impurities present in the plasma was estimated by admitting a small amount of methane or carbon dioxide into the tube and observing with a monochromator the resulting increase in intensity of a carbon or an oxygen spectral line. The particle density of carbon or oxygen determined in this way is about 0.2%.

It may be noted from Refs. 3 and 4 that the decaying plasma is electrically isolated from its container, even though the conducting tube has a much higher conductivity than the plasma. For instance, in the Alfvén wave experiments it was found that the boundary condition to be applied was appropriate for a glass (i. e., nonconducting) tube. As observed experimentally, a high-density current flow from plasma to wall can maintain electrical contact between them.

Details of Construction

Most of the cost and effort is involved in providing the magnetic field. In these experiments a continuous magnetic field was used because water-cooled magnets, silicon rectifiers, and alternating current capacity were available. In most cases it is more convenient and economical to use a pulsed magnetic field with a half-cycle time of 10 msec, supplied by an electrolytic capacitor bank. We have constructed such pulsed magnets and capacitor banks for use with other experiments.

A uniform magnetic field can be obtained with a simple close-wound coil by using only the central volume, i. e., by avoiding the volume within two wire diameters of the coil or within one coil diameter of the ends, as shown in Fig. 1. For coils of practical dimensions, about one-half the volume is useful uniform field. It is possible to design coils that enclose a greater fraction of usable volume, but such coils are more difficult to fabricate and trim satisfactorily. In the design discussed here the annular volume between the tube and the coil is available for experimental probes and diagnostics.

The capacitor bank is designed from energy considerations. The energy supplied to the magnetic field must be stored in a capacitor bank at some practical level which is dependent upon switching, connecting cable, and coil-insulation problems. In order to use standard welding cables for connections and for simplified coil construction, the upper limit for bank voltage is set at 5 kilovolts. Since the magnetic energy in a 20-kgauss field is about 2 joules/cm^3 , the total energy calculated from the coil dimensions, including I^2R losses and about 25% for the fringing field, is 150 kjoules. The required capacitance is then 12,000 microfarads. This value is rather easily attained with electrolytic capacitors. The bank is subdivided into

twelve modular sections to prevent the entire bank from participating in an internal failure should one occur. The switching is accomplished with one ignitron for each section. A circuit diagram for a typical modular section is shown in Fig. 8. The output of each section is connected to the magnet coil through a pair of No. 1 welding cables, which should be at least 15 feet long. The inductance associated with these cables provides isolation and protects each modular unit from a failure in another unit or in the coil. In three years of operation into various loads the capacitor replacement rate has been less than 1/2% per year. There has been no occasion on which bank troubles have interfered with experimental work.

With the capacitor parameters determined, one can now design the magnet coil. In order to minimize the large stray field caused by leads to a single-layer solenoid, a two-layer coil is used. To provide access to the center of the machine, the coil is split into two identical units connected in series. Provision of an epoxy-fiberglass-bonded outer shell and epoxy impregnation between turns supplies the strength necessary to resist magnetic forces. The coil is close wound with No. 1 T W Thermoplastic-insulated standard commercial copper wire with the first layer wrapped on an 8-in. -diameter commercially available epoxy-fiberglass tube having a 1/8-inch wall. Each layer is painted with epoxy resin. The interlayer insulation is two turns of 1/32-in. -thick epoxy-fiberglass laminate. After the second layer of wire has been wrapped, five layers of 1/32-in. -thick fiberglass fabric are wrapped with epoxy resin brushed in between each layer.

The coils should be firmly mounted, and if they are separated by an inch or two to provide access for diagnostic equipment, attention must be given to the fact that an axial force of several tons will tend to bring them together when the magnetic field is applied.

The ionizing pulse line must supply the ionization energy plus the kinetic energy of the rotating plasma, and should be charged to about 10 kv so as to have an electric field large enough to break down the gas. We used ten 7.5- μ f capacitors, with two 5550 ignitrons in parallel used for switching, as shown in Fig. 1. Output is brought to the tube with six RG-8/U coaxial cables. The pulse line is enclosed in a shielded box to minimize the radiation of high-frequency noise and transients. A series resistance R of one ohm was used. This was constructed from a strip of stainless steel 0.001-in. - thick, 1-in. wide, and 9 ft long, insulated with glass tape and folded to form a compact unit. The crowbar switch is a 5550-ignitron tube connected as shown in Fig. 1 and actuated in the same manner as the switching ignitron. Commercially available delay circuits can be used to provide the necessary delays for the switching and crowbarring ignitrons, i. e., after the magnet is pulsed on there must be a delay of several milliseconds until the magnet current has reached its maximum value. At this time the switching ignitron is fired; there is then a delay of about 15 μ sec, and then the crowbar ignitron is fired. The circuit used to fire the ignitrons is shown in Fig. 9.

The voltage between the coaxial electrode and the tube, and the ionizing current, should be monitored with an oscilloscope. The voltage can be measured with a resistive divider made up of ten 1000-ohm 2-watt carbon resistors connected in series with a terminal resistor of 51 ohms (or whatever may be the characteristic impedance of the coaxial cable that is used to bring the signal to the oscilloscope). In general, we find that for short pulses a 2-watt carbon resistor can take 2 kv and dissipate 10 joules. The ionizing current can be conveniently measured by integrating the output of a simple air-core current transformer mounted alongside an unshielded section of the cable.

Gas breakdown at low pressures can be facilitated by installing a spark plug in the center of the coaxial electrode.

The tube must be constructed of a material that has the necessary mechanical strength and that will permit the penetration of the pulsed magnetic field into the volume. Simple skin-depth considerations do not describe the case in which full field penetration into a volume is desired. The L_1/R time for the tube must be small compared with L_2C , where L_1 and R are the inductance and resistance of the tube considered as a single turn, and L_2 and C are the inductance and capacitance of the magnet coil and capacitor bank. For this case we selected a 6-in. -diameter stainless steel tube having a 1/16-inch wall. The end plates are attached by standard vacuum techniques. If organic O rings are used for vacuum seals, they must be shielded from contact with the plasma. The electrode must also be constructed of thin-wall material in order to allow penetration of the magnetic field.

Changes in Experimental Conditions

A particular set of conditions has been described. For a proposed experiment it might be desirable to change the plasma density or composition, the degree of ionization, the size of the tube, or the magnetic field strength. Although any proposed change would have to be investigated experimentally, it may be useful for us to speculate on possible changes. Figure 3 shows that the ionizing wave proceeds down the tube at a constant velocity. This suggests that the tube could be made considerably longer (or shorter). We have used a 20-cm-diameter tube in an ion cyclotron resonance experiment, and believe that the tube diameter could be increased further if desired. Presumably the voltage on the ionizing pulse line would have to be increased. The ionizing pulse line could be replaced with a capacitor in many cases.

Stainless steel would probably be satisfactory for the electrode material. Brass should not be used for this purpose.

Two changes in the shape of the driving electrode have been tried. A small electrode, 1/2 in. in diameter and 1/2 in. long, produced poor results, and when the tube was disassembled and inspected the electrode was badly pitted; this suggests that the electric field strength and current density were too high on this small surface. A 2-in. -diameter, 1/4-in. -long electrode was also tried, again with poor results. The ionizing current flowed normally for a few μ sec and then abruptly increase with an accompanying voltage drop, suggesting an internal breakdown along the insulator.

A range of magnetic field strength from 7 to 20 kgauss has been covered in the Alfvén wave work, although the Stark broadening measurements have been performed mainly at 16 kgauss. The field strength could probably be increased; the lower limit of field required has not been determined.

Below a hydrogen gas pressure of about 10^{-3} mm Hg (1 μ) the tube does not break down, at least with our present geometry and applied voltage. In the region from 10^{-3} to a few times 10^{-2} mm Hg the spark plug mentioned above is necessary in order to obtain reliable breakdown. At low pressures there may be a larger amount of impurities present, also an anode sheath voltage drop may appear. The pressure can certainly be increased above our operating point at 0.1 mm Hg; however, if the pressure is increased too much it may not be possible to obtain a high degree of ionization. We have briefly tried gases other than hydrogen and the tube seems to operate in a similar manner; however, no detailed study has been made. If any of the above changes are made, the design of the electrolytic condenser bank and ionizing pulse line must be suitably modified.

REFERENCES

*This work was performed under the auspices of the U. S. Atomic Energy Commission.

1. T. K. Allen, W. R. Baker, R. V. Pyle, and J. M. Wilcox, Phys. Rev. Letters 2, 383 (1959).
2. J. M. Wilcox, F. I. Boley, and A. W. DeSilva, Phys. Fluids 3, 15 (1960).
3. J. M. Wilcox, A. W. DeSilva, W. S. Cooper III, and F. I. Boley, Experiments on Alfvén Wave Propagation, in Proceedings of Fifth Annual Lockheed Symposium on Magnetohydrodynamics, 1960 (Lawrence Radiation Laboratory Report UCRL-9482, Dec. 1960).
4. A. W. DeSilva, W. S. Cooper III, and J. M. Wilcox, Alfvén Wave Reflections and Propagation Modes, Lawrence Radiation Laboratory Report UCRL-9496, Jan. 1961.
5. W. S. Cooper III, A. W. DeSilva, and J. M. Wilcox, Ion Density Measurements in a Decaying Hydrogen Plasma, 13th Gaseous Electronics Conference, Monterey, California, Oct. 12-15, 1960, Paper E-9. (Lawrence Radiation Laboratory Report UCRL-9509, Jan. 1961).
6. H. R. Griem, A. C. Kolb, and K. Y. Shen, Phys. Rev. 116, 4 (1959); idem Naval Research Laboratory Report NRL-5455, 1960.

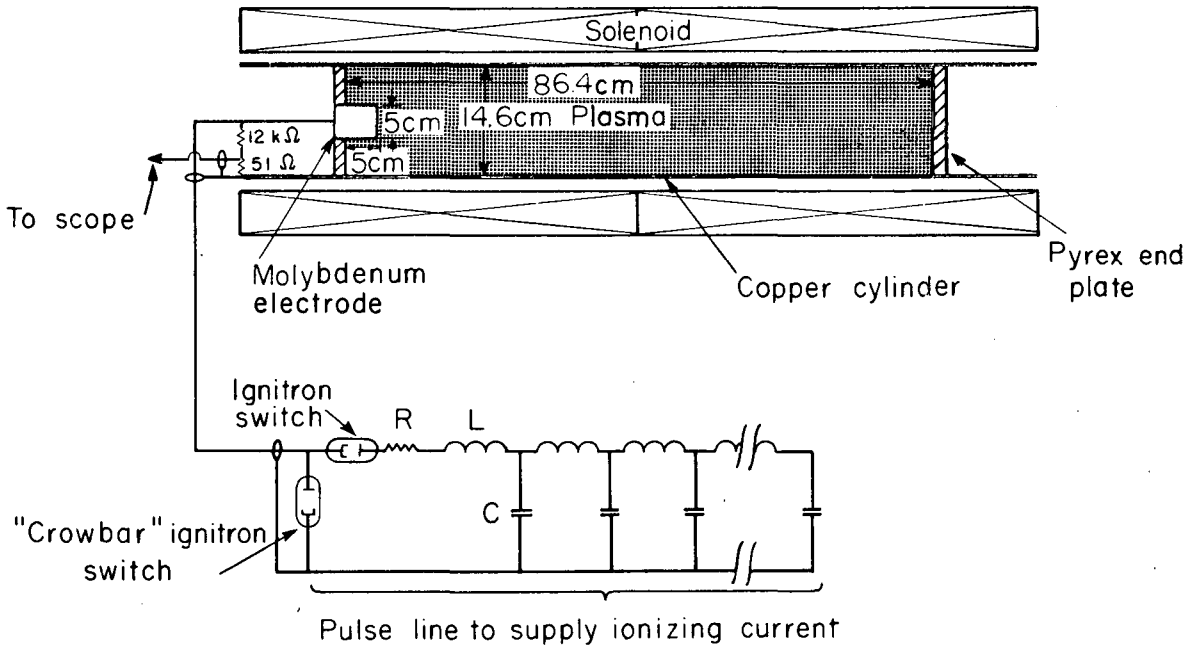

MU-22165-A

Fig. 1. Experimental geometry.

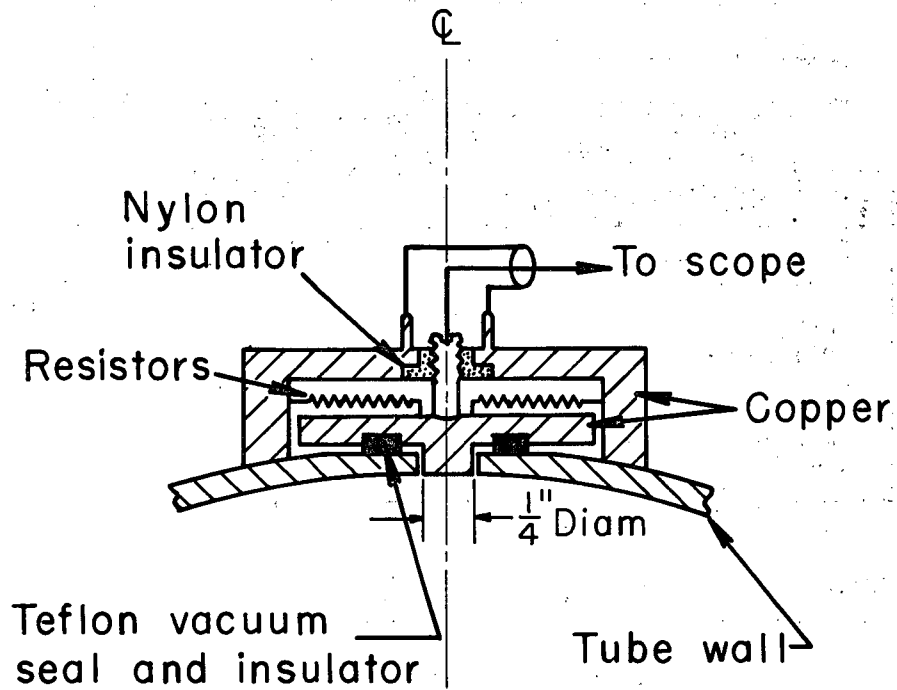

MU-20358

Fig. 2. Geometry of the radial current probe. The 1/4-in. diameter button is connected to the adjacent wall through six parallel 5-ohm resistors. The maximum voltage drop is less than 1 volt.

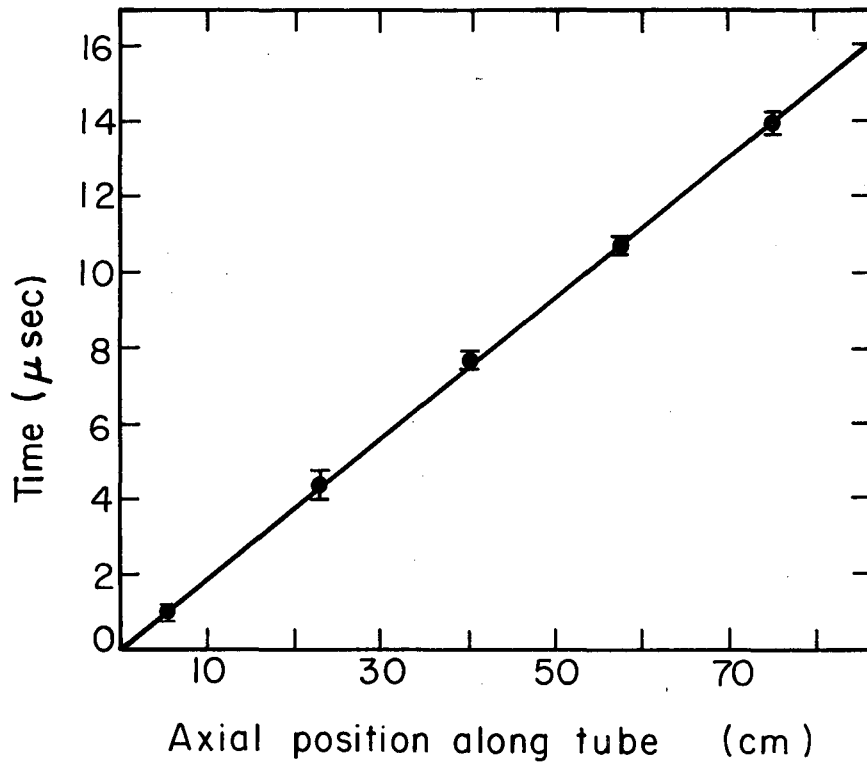

MU-20359

Fig. 3. Position of the ionizing front vs time, as measured with radial current probes.

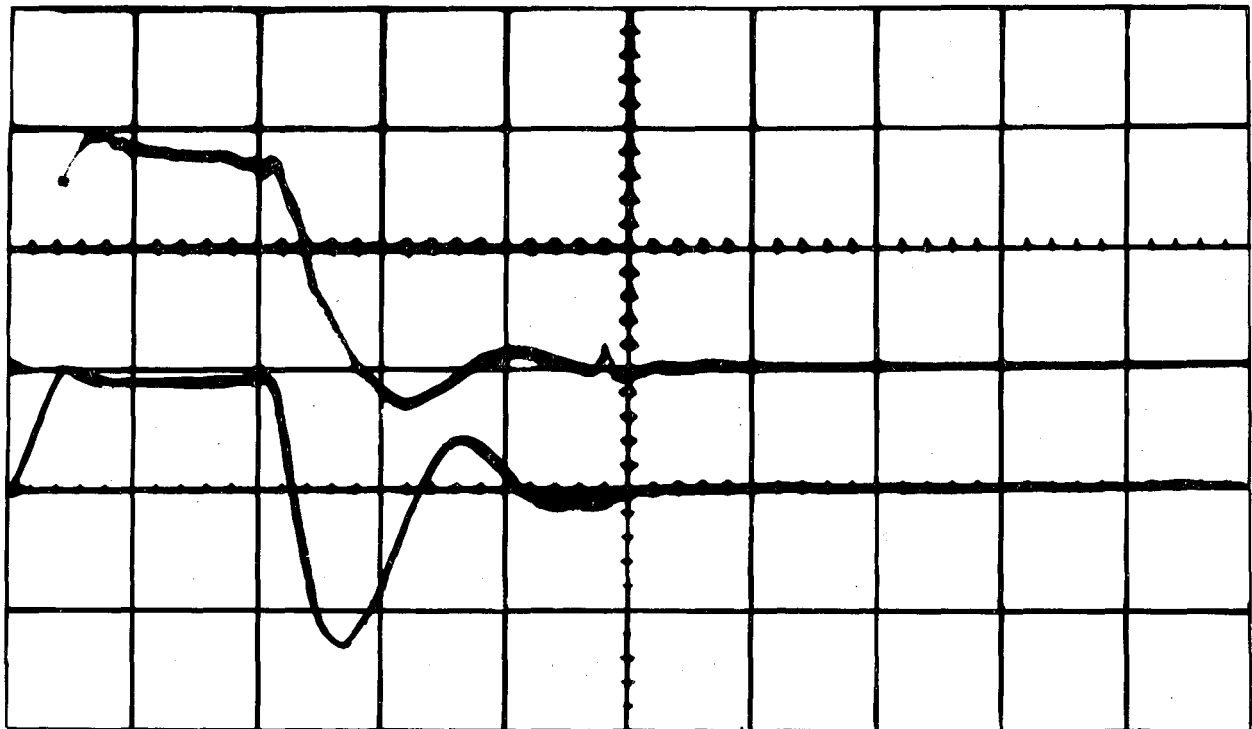

ZN-2492

Fig. 4. Oscilloscope traces showing ionizing conditions. The top trace is voltage on the driving coaxial electrode at 2400 volts/cm and the bottom trace is current from the pulse line at 10^4 amp/cm. The horizontal scale is $10 \mu\text{sec/cm}$. The current was crowbarred $22 \mu\text{sec}$ after the voltage was first applied.

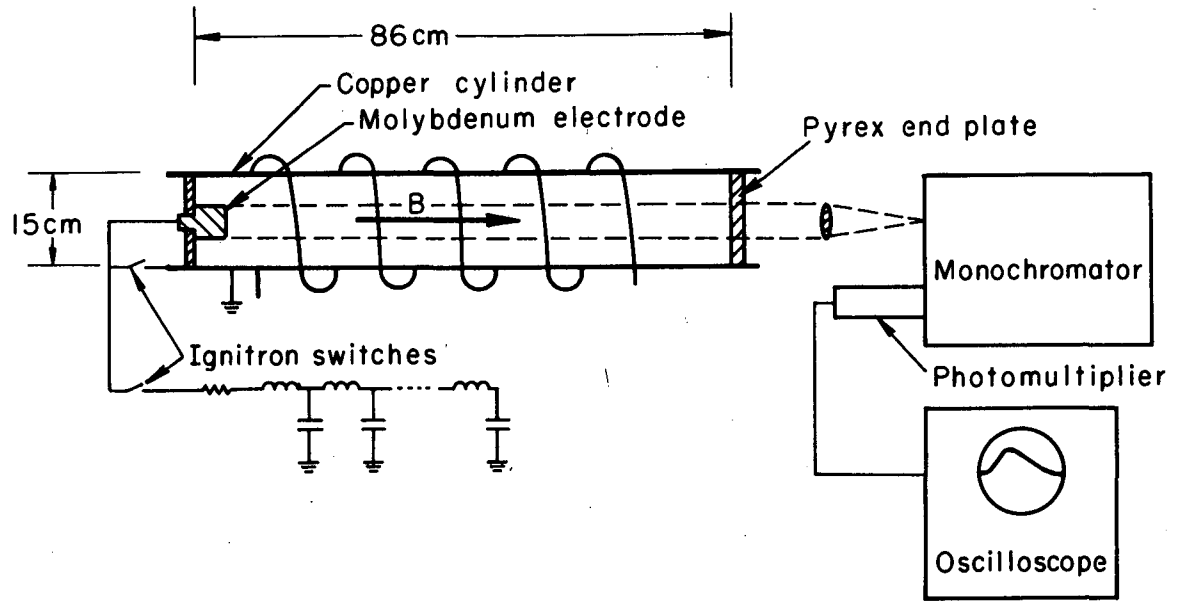

MU-21659

Fig. 5. Monochromator geometry.

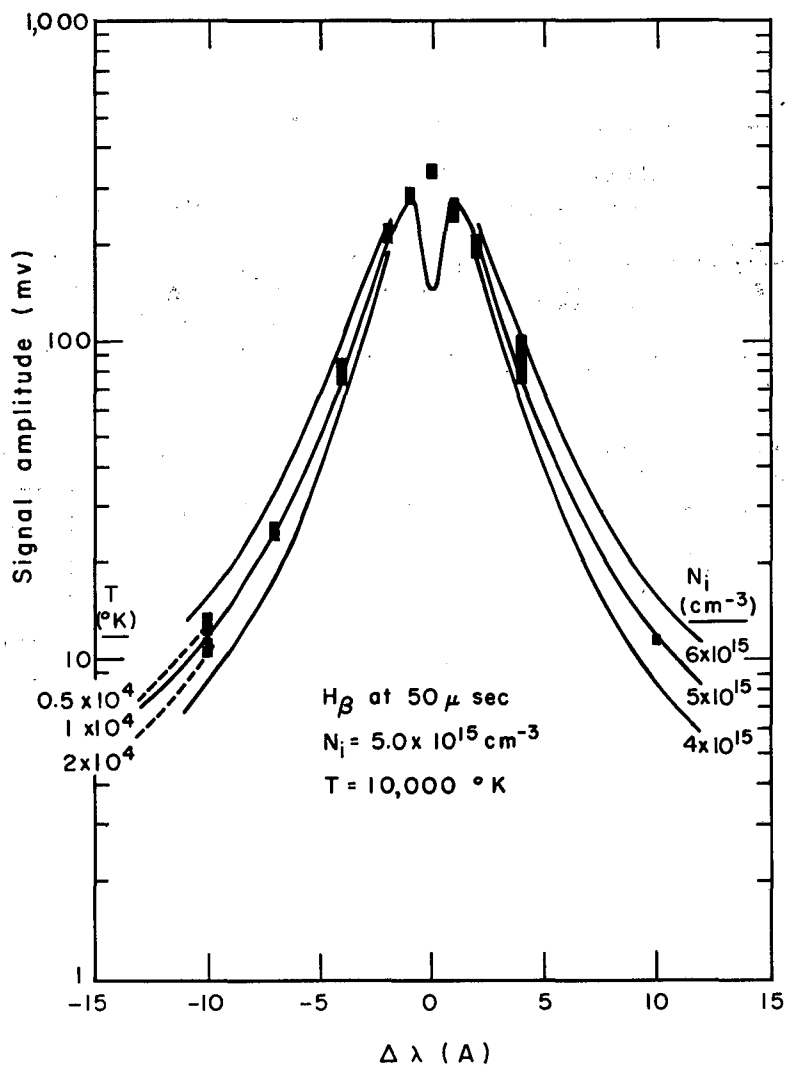

MU-21657

Fig. 6. H_{β} profile, showing several theoretical profiles for comparison purposes.

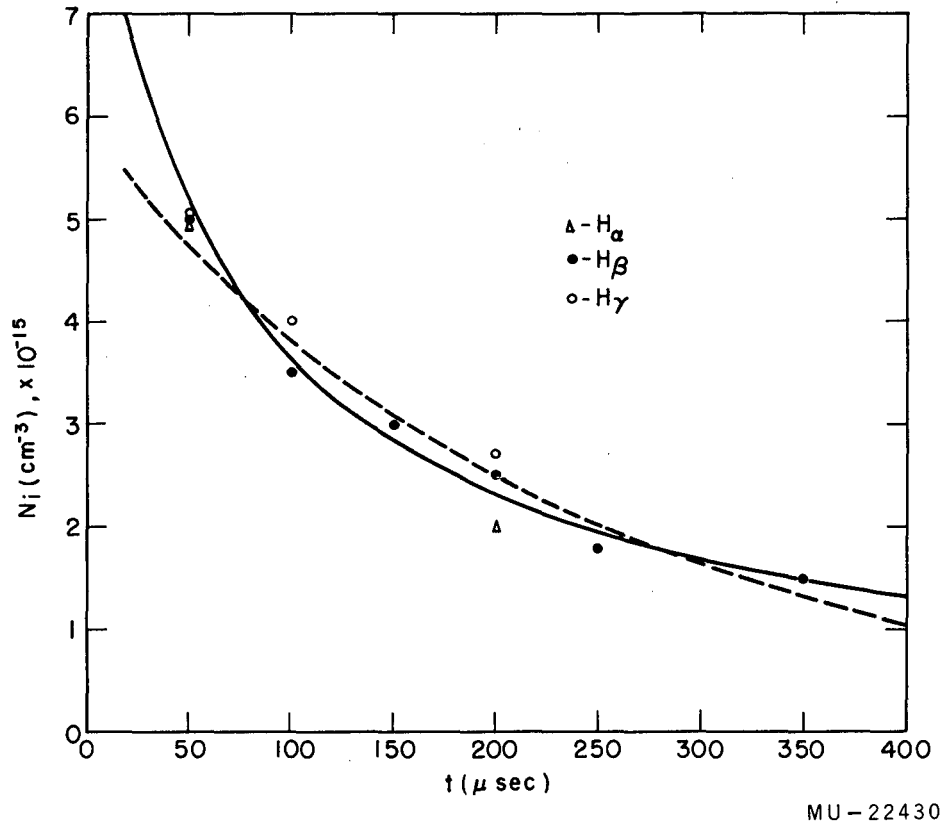

MU-22430

Fig. 7. The observed time dependence of the ion density. Errors (not shown) in the experimental points are estimated to be $\pm 1.0 \times 10^{15} \text{cm}^{-3}$ late in the decay period. Solid line: least-squares fit, decay rate assumed proportional to the square of the ion density; dashed line: exponential decay assumed.

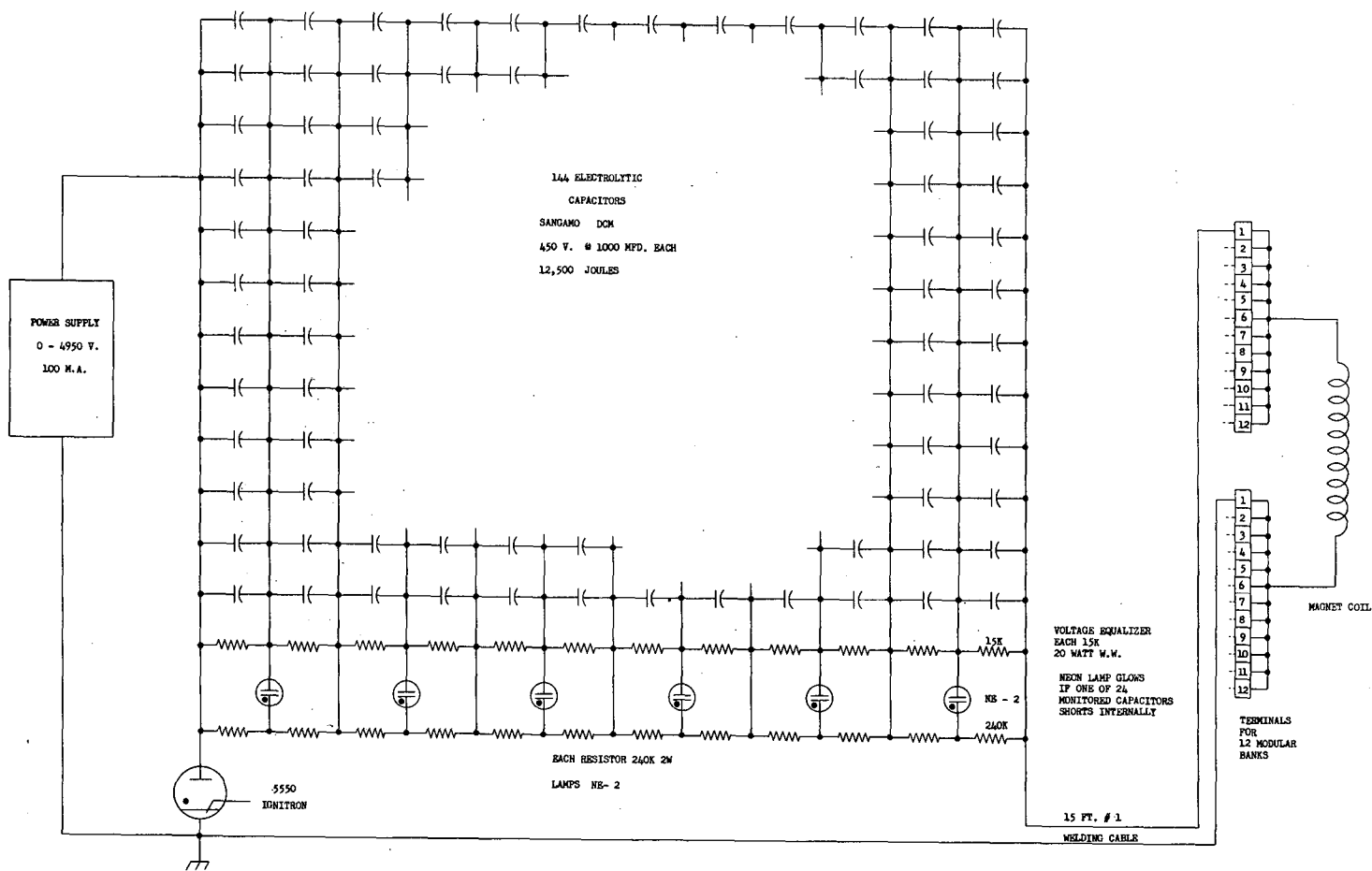

Fig. 8. Schematic of modular section of electrolytic capacitor bank. One of twelve modular units.

MUB-583

This report was prepared as an account of Government sponsored work. Neither the United States, nor the Commission, nor any person acting on behalf of the Commission:

- A. Makes any warranty or representation, expressed or implied, with respect to the accuracy, completeness, or usefulness of the information contained in this report, or that the use of any information, apparatus, method, or process disclosed in this report may not infringe privately owned rights; or
- B. Assumes any liabilities with respect to the use of, or for damages resulting from the use of any information, apparatus, method, or process disclosed in this report.

As used in the above, "person acting on behalf of the Commission" includes any employee or contractor of the Commission, or employee of such contractor, to the extent that such employee or contractor of the Commission, or employee of such contractor prepares, disseminates, or provides access to, any information pursuant to his employment or contract with the Commission, or his employment with such contractor.

