

UCLA
Posters

Title

Real-Time Acoustical Beamforming

Permalink

<https://escholarship.org/uc/item/05z036s7>

Authors

Bergamo, Pierpaolo
Maniezzo, Daniela
Wang, H B
[et al.](#)

Publication Date

2003-10-10

Real-Time Acoustical Beamforming

P. Bergamo, D. Maniezzo, H. Wang, L. Yip, D. Estrin, K. Yao
CS – EE Depts, UCLA

Sensor Network for an Audio Source Localization

Audio Source Localization problem

- The main purpose of a sensor network is to monitor an area, including detecting, identifying, localizing, and tracking one or more objects of interest.
We consider the use of simple PDAs (Personal Digital Assistant) to realize an audio localization system.

Beamforming

- Beamforming is a space-time operation in which a waveform originating from a given source but received by spatially separated sensors, are combined in a time-synchronous manner. If the propagation medium preserves sufficient coherency among the received waveforms, then the beamformed waveform can provide an enhanced Signal-to-Noise-Ratio (SNR) compared to a single sensor system.
- Beamforming can be used to determine the *direction-of-arrival(s)* and the *location(s)* of the source(s).

Real time Beamforming using a commercial-off-the-shelf (COTS) products

Novelty: in the past the beamforming was performed using custom-made hardware, we propose to perform beamforming using **Compaq iPAQ 3760s** as sensors, processors and transmitters/receivers.

Why iPAQ?

For its compactness,
reasonable battery life,
GNU/Linux open-source operating system support,
built-in microphone and codec.
It also supports IEEE802.11b and IEEE802.3 cards.



Problems

- Floating-point operations
- Synchronization
- Accuracy of the sampling sub-system

Proposed Solution

Intra-Array Communication

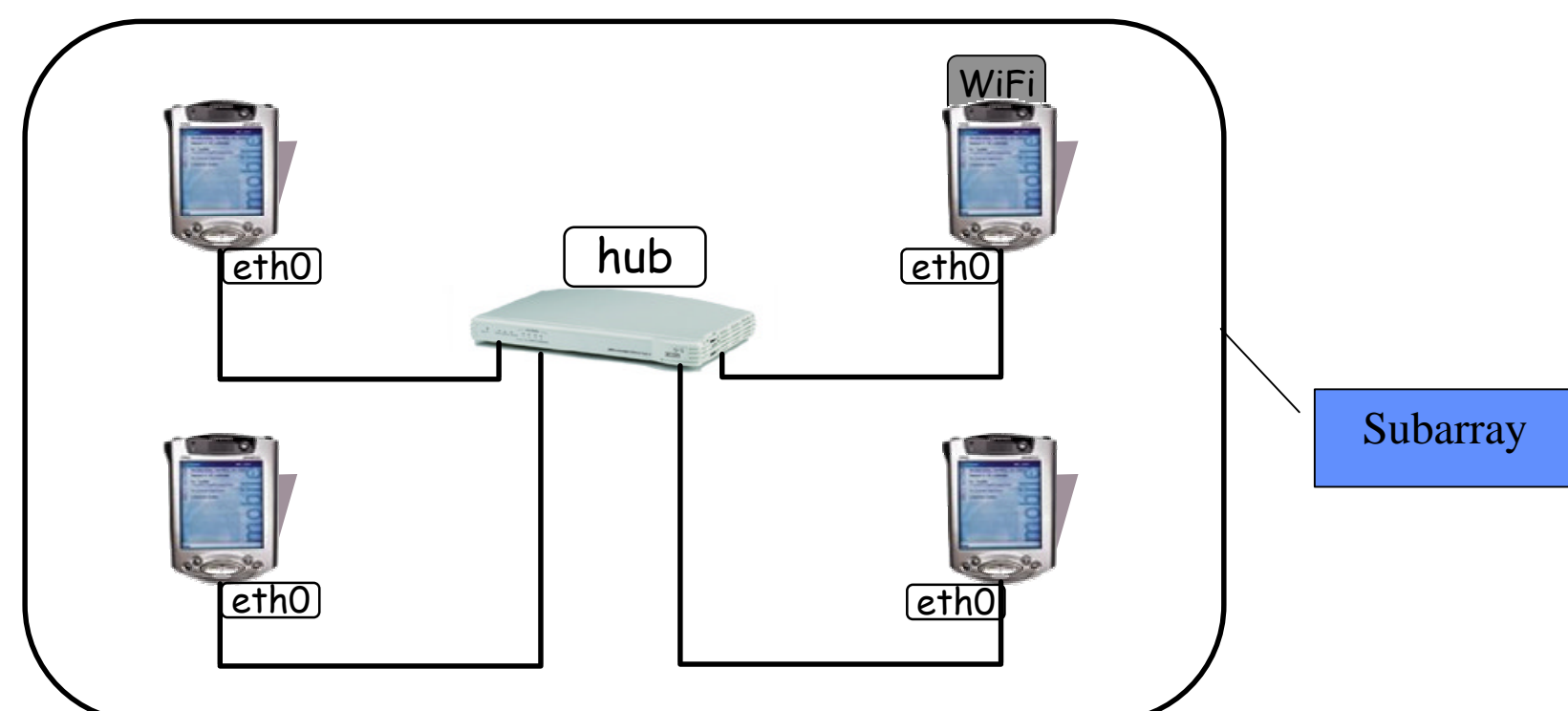

Inter-Array Communication

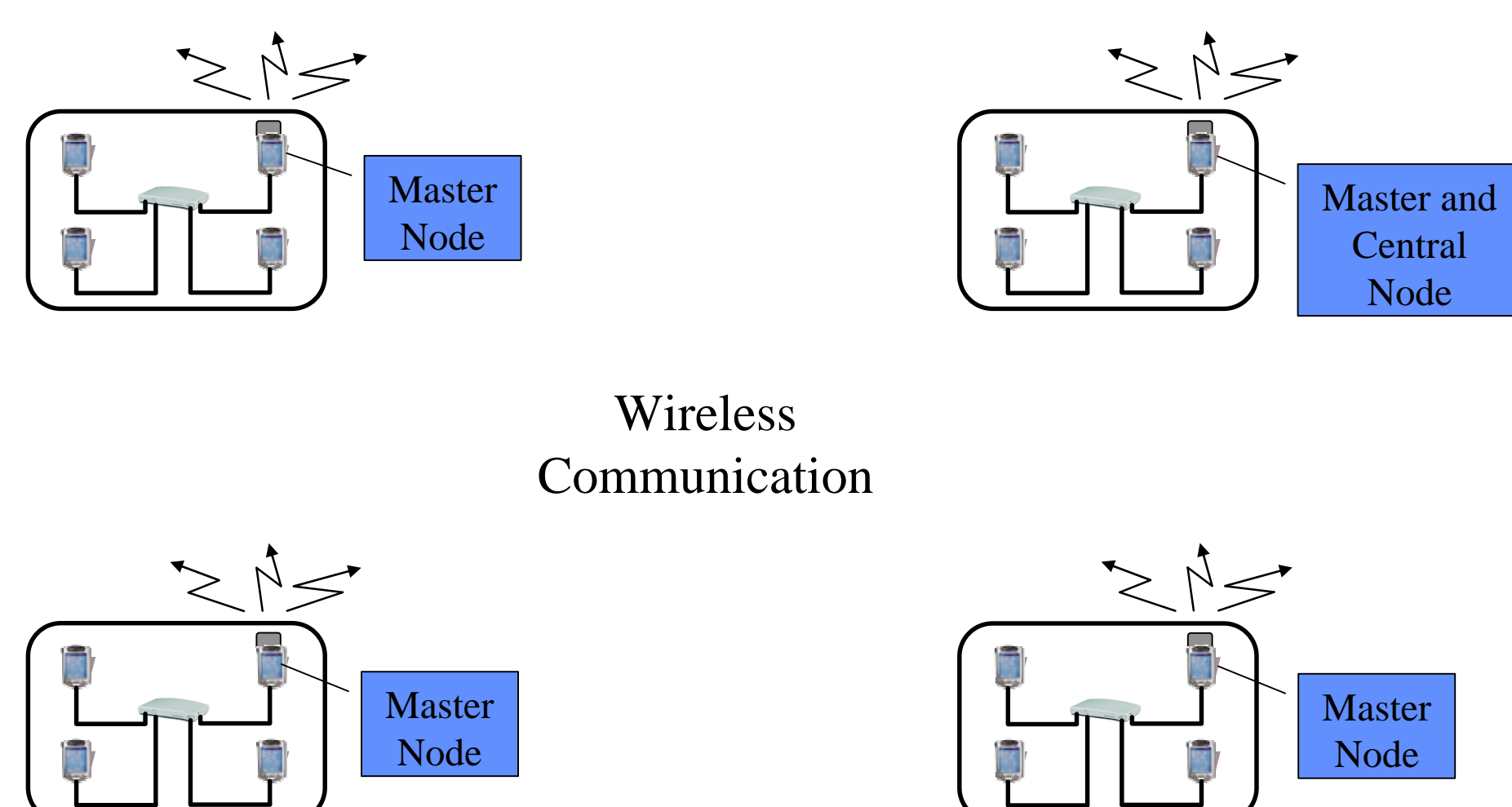

- A subset of iPAQs forms a **subarray**.
- Each sensor of the subarray acquires audio samples, performs a FFT on them. All the FFTs are sent to one of the sensors in the subarray (the **master node**).
- Once the DOA is computed, each master node sends this information to the **central node**.
- The central node estimates the position by crossing the bearings.

Results

