

UC Riverside

UC Riverside Electronic Theses and Dissertations

Title

Semistar Operations on Integral Domains and Multiplicative Lattices

Permalink

<https://escholarship.org/uc/item/057405nk>

Author

Choi, Hyun Seung

Publication Date

2017

Peer reviewed|Thesis/dissertation

UNIVERSITY OF CALIFORNIA
RIVERSIDE

Semistar Operations on Integral Domains and Multiplicative Lattices

A Dissertation submitted in partial satisfaction
of the requirements for the degree of

Doctor of Philosophy

in

Mathematics

by

Hyun Seung Choi

June 2017

Dissertation Committee:

Professor David E. Rush, Chairperson
Professor Wee Liang Gan
Professor Carl Mautner

Copyright by
Hyun Seung Choi
2017

The Dissertation of Hyun Seung Choi is approved:

Committee Chairperson

University of California, Riverside

Acknowledgments

I thank Professor David E. Rush for his guidance, assistance and patience throughout the writing of this thesis. I wish to express my appreciation to Dr. Youngsu Kim for his kindness, several helpful advice and encouragement. My gratitude also goes to Donna Blanton, Matt O'Dell, Josh Strong, Jordan Tousignant and Parker Williams for their constant cordiality. Lastly, I would like to mention that collaborating with Andy Walker was one of the best things ever happened to me.

*To my parents and my sister for their support, as well as the professors who
inspired me to pursue this goal.*

ABSTRACT OF THE DISSERTATION

Semistar Operations on Integral Domains and Multiplicative Lattices

by

Hyun Seung Choi

Doctor of Philosophy, Graduate Program in Mathematics
University of California, Riverside, June 2017
Professor David E. Rush, Chairperson

The goal of this dissertation is to investigate the properties of semistar operations on integral domains and multiplicative lattices in terms of their natural partial ordering. We mainly focus on the relationships between different classes of integral domains in terms of semistar operations.

Contents

1	Introduction	1
2	Preliminaries	6
2.1	Localizing systems and semistar operations	6
2.2	*-cancellation ideals and *-invertible ideals	13
3	When is there a semistar operation that properly sits between two semistar operations?	17
4	On the composition and partial ordering of the set of semistar operations	23
4.1	Composition of two semistar operations	23
4.2	Prüfer domains and P*MDs	29
4.3	Semistar operations of type $v(I)$	37
4.4	Semistar operations on the ring $R = L + X^3L[[X]]$	47
4.5	When $(SStar(R), \leq)$ is a totally ordered set	50
5	Semistar operations on PVDs, Noetherian domains and Mori domains	59
5.1	Semistar operations on PVDs	59
5.2	Integral domains having four semistar operations	66
5.3	On Mori c^* -domains and totally divisorial conducive domains	74
5.4	Summarization of implications and equivalencies	81
6	Semistar operations on Multiplicative lattices	87
6.1	Multiplicative lattices	88
6.2	Semistar operations on q.f. lattices	92
6.3	Localizing systems on q.f. lattices	96
6.4	Invertibility of semistar operations on q.f. lattices	102
7	Further questions	108
	Bibliography	110

Chapter 1

Introduction

The notion of star operations on the set of fractional ideals of an integral domain originates from the work of Krull ([42]), and was considered by several authors; Gilmer([29]), Jaffard ([40]) and Halter-Koch ([30]) to name a few. Semistar operations were first introduced by Matsuda and Okabe in their 1994 paper ([47]), as a generalization of star operations. Semistar operations has fewer axioms than star operations, and is defined on the set of nonzero submodules of the quotient field of a domain instead of the set of fractional ideals of a domain. Due to weaker regulation compared to that of star operations, the theory on semistar operations has been proved to be an apt tool to study the overrings of a domain. Many authors, for example, El Baghdadi, Fontana and Picozza ([7]), Matsuda ([46]), Matsuda and Okabe ([47]), Mimouni ([51]), Mimouni and Samman ([53]) and Picozza ([68]) studied and investigated semistar operations on overrings. The present thesis is aimed to follow the same path, focused on the set of domains where the composition of two semistar operations yields a semistar operation (such domains will be called c^* -domains. See Lemma 4.2.8). The author was unable to find a nice ring-theoretical characterization of c^* -domains, but various classes of in-

tegral domains could be linked together via it. On the other hand, the set of semistar operations of an integral domain R whose quotient field is K can be partially ordered as follows; given two semistar operations $*_1$ and $*_2$ of an integral domain R , $*_1 \leq *_2$ if and only if $I^{*1} \subseteq I^{*2}$ for each nonzero R -submodule I of K . The motivation of one of the main results of this dissertation comes from the attempt to characterize the integral domains whose set of semistar operations is totally ordered under \leq (such domains will be called t^* -domains in this dissertation). For instance, in section 4.5 we prove that an integrally closed domain R is a t^* -domain if and only if R is a valuation domain. We also show that given an integer $n \geq 3$ there exists a nonintegrally closed (thereby nonvaluation) t^* -domain R_n that has n semistar operations and the set of semistar operations of R_n is totally ordered under \leq .

This thesis consists of three parts. In chapters 2 and 3 we attempt to find a condition when there is a semistar operation that lies in between two semistar operations. Chapter 2 acts as a preliminary to the subsequent chapters. In section 2.1, we briefly state the definition and some well-known properties of semistar operations. Section 2.2 is about the $*$ -cancellation ideals and $*$ -invertible ideals which first appeared in [1]. $*$ -cancellation ideals are closely related to the constructions and proofs of the theorems in the following section. We review their properties and obtain some generalized results in terms of spectral semistar operations. In chapter 3, we show that under a certain restriction, there exists a semistar operation that lies between two semistar operations; precisely, we prove that if $*_1$ and $*_2$ are distinct semistar operations of finite type and stable such that $I^{*1} \subseteq I^{*2}$ for each $I \in \overline{F}(R)$ and $J^{*1} = J^{*2}$ for some $J \in f(R)$, then there exists a non-stable finite type semistar operation $*$ different from both $*_1$ and $*_2$ such that $I^{*1} \subseteq I^* \subseteq I^{*2}$ for each $I \in \overline{F}(R)$.

The second topic is about the composition of two semistar operations on an integral domain. The composition of semistar operations were first considered by Picozza ([68]). He proved that if each composition of two arbitrary semistar operations on an integral domain yields a semistar operation, then that domain must be conducive ([68, Example 2.1(1)]). In section 4.1, we prove that the composition of a semistar operation of finite type and a stable semistar operation is a semistar operation, and define a new type of semistar operation induced by this composition. Using this semistar operation, a characterization theorem of the P*MD and a few other classes of Prüfer domains is obtained in section 4.2. In particular, we show that an integral domain R is totally divisorial valuation domain if and only if each semistar operation on R is of finite type and stable. We also provide a partial answer to Fontana and Huckaba's problem ([21, p.181]) concerning the characterization of a certain type of localizing systems. See section 2.1 for the definitions and some basic properties of localizing systems. The interested reader may consult [21] for more details.

The third topic is about the operation $v(I)$, and the integral domains whose set of semistar operations is totally ordered under \leq . Heinzer, Huckaba and Papick showed that for a fixed ideal I of R with $I : I = R$, the map $v(I) : F(R) \rightarrow F(R)$ defined by $L^{v(I)} = I : (I : L)$ for each $L \in F(R)$ is a star operation ([34, Proposition 3.2]). Picozza proved that for an arbitrary nonzero R -submodule I of K , the above map $v(I)$ defined on $\overline{F}(R)$ is a semistar operation ([69, Proposition 1.17(2)]). Some interesting results regarding this type of semistar operation is displayed in section 4.3. In fact, we prove that an integral domain R is totally divisorial and conducive if and only if R is a stable domain such that given a semistar operation $*$ on R there exists an ideal I of R so $*$ = $v(I)$.

Section 4.4 is devoted to the classification of semistar operations on the ring $L+X^3L[[X]]$ where L is a field and X an indeterminate, which acts as a counterexample to the converse of some of the theorems in section 4.5.

In section 4.5, we prove that the set of semistar operations on a valuation domain is totally ordered, and for integrally closed domains the converse is also true. On the other hand, the proof that the set of overrings of a totally divisorial conducive domain is totally ordered under inclusion is also provided.

In chapter 5 we turn our attention to semistar operations on PVDs, Mori domains and Noetherian domains. For instance, in section 5.1, we prove that if R is a PVD, then R has at most two star operations if and only if the set of semistar operations on R is totally ordered if and only if each semistar operation $*$ on R is of the form $v(I)$ for some nonzero ideal I of R . In section 5.2, a characterization of integral domains having exactly four semistar operations, and the examples of integral domains that correspond to each of those cases are provided. In section 5.3, it is shown that given a Mori domain R whose set of semistar operations is closed under composition, the set of overrings of R is a finite set that is totally ordered under inclusion. We also provide a formula regarding the calculation of the number of semistar operations on a totally divisorial conducive domain. Moreover, it is proved that a numerical semigroup ring is a totally divisorial conducive domain if and only if its set of semistar operation is totally ordered if and only if the composition of two arbitrary semistar operations gives a semistar operation. In section 5.4, some of the theorems are rephrased in more polished form, illustrated with a diagram. In chapter 6, we switch our field of interest to multiplicative lattices from integral domains. In particular, we study a class of multiplicative lattices called quotient field lattices, which is could be considered as a lattice version of an

integral domain. We define semistar operations on quotient field lattices, and prove some theorems corresponding to commutative rings. For instance, we show that on a Krull lattice the semistar operations induced by different subsets of prime elements coincide. Lastly, we list some further research questions the author was unable to answer.

All rings R are assumed to be integral domains. K will denote the quotient field of R , $\mathcal{S}(R)$ the set of ideals of R , $\mathcal{S}'(R)$ the set of proper ideals of R and $f\mathcal{S}(R)$ the set of finitely generated ideals of R . $\overline{F}(R)$ will denote the set of nonzero R -submodules of K . An overring of R is an integral domain T such that $R \subseteq T \subseteq K$. Given an overring T of R and two R -submodules I, J of K , $I :_T J = \{t \in T \mid tJ \subseteq I\}$. In case $T = K$, we will use the notation $I : J$ to denote $I :_K J$ and I^{-1} to denote $R : I$. $O(R)$ will denote the set of overrings of R . Given $N \in \overline{F}(R)$, N is said to be a fractional ideal if $R : N \neq 0$. $F(R)$ (respectively, $f(R)$) will denote the set of fractional ideals of R (respectively, the set of finitely generated fractional ideals of R). The integral closure of R will be denoted by R' . Given an R -modules S , $l(S)$ denote the length of the composition series of S . $\mathbb{N}, \mathbb{N}_0, \mathbb{Z}, \mathbb{Q}$ and \mathbb{R} denote the set of positive integers, nonnegative integers, integers, rational numbers and real numbers, respectively.

Chapter 2

Preliminaries

2.1 Localizing systems and semistar operations

([21, Section 2]) Recall that a *localizing system* \mathcal{F} of an integral domain R is a nonempty family of ideals of R such that the following conditions hold:

(LS1) If $I \in \mathcal{F}$ and J is an ideal of R such that $I \subseteq J$, then $J \in \mathcal{F}$.

(LS2) If $I \in \mathcal{F}$ and J is an ideal of R such that $(J :_R i) \in \mathcal{F}$ for each $i \in I$, then $J \in \mathcal{F}$.

Furthermore, given a localizing system \mathcal{F} of R , $\mathcal{F}_f = \{I \in \mathcal{F} \mid J \subseteq I \text{ for some finitely generated } J \in \mathcal{F}\}$ is a localizing system ([21, Lemma 3.1]), and we say that \mathcal{F} is of *finite type* if $\mathcal{F} = \mathcal{F}_f$.

Definition 2.1.1. Let S be a subset of $\mathcal{S}(R)$. We say S is *multiplicatively closed* if the following conditions hold.

1. $R \in S$.
2. If $I \in S$ and $J \in S$, then $IJ \in S$.

Lemma 2.1.2. *Let R be a domain, and S a multiplicatively closed subset of $fS(R)$. If*

$$\mathcal{F}_S = \{I \in \mathcal{S}(R) \mid J \subseteq I \text{ for some } J \in S\},$$

then \mathcal{F}_S is a finite type localizing system on R .

Proof. It is clear that (LS1) holds. We next claim that \mathcal{F}_S is multiplicatively closed and is closed under finite intersections. Indeed, if $I, I' \in \mathcal{F}_S$, then there are $J, J' \in S$ with $J \subseteq I, J' \subseteq I'$, so that $JJ' \subseteq II' \subseteq I \cap I'$, and since S is multiplicatively closed, $JJ' \in S$. Hence II' and $I \cap I'$ are both in \mathcal{F}_S .

Now we show that \mathcal{F}_S satisfies (LS2). Choose ideals I, J of R so that $I \in \mathcal{F}_S, (J :_R iR) \in \mathcal{F}_S$ for all $i \in I$. We have to show that $J \in \mathcal{F}_S$. There exists $I' \subseteq I$ with $I' \in S$. Let $\{i_k\}$ be a finite generating set of I' . It follows that $(J :_R I') = (J :_R \sum i_k R) = \cap (J :_R i_k R)$, so $(J :_R I') \in \mathcal{F}_S$ and $I'(J :_R I') \in \mathcal{F}_S$ by the above claim. Then $J \in \mathcal{F}_S$ since $I'(J :_R I') \subseteq J$ and by (LS1). Lastly, by definition it follows that \mathcal{F}_S is of finite type. □

Now we can turn our attention to semistar operations.

Definition 2.1.3. A *semistar operation* on an integral domain R is a map $*$: $\overline{F}(R) \rightarrow \overline{F}(R)$ such that for any $I, J \in \overline{F}(R)$ and $x \in K \setminus \{0\}$,

1. $I \subseteq I^*$.
2. $I \subseteq J$ implies $I^* \subseteq J^*$.
3. $(xI)^* = xI^*$.
4. $(I^*)^* = I^*$.

A semistar operation $*$ on R is called a *(semi)star operation* if $R^* = R$. Semistar operations were first introduced by Matsuda and Okabe in their 1994 paper [62], extending the notion of ‘classical’ star operation ([29, Chapters 32 and 34],[48]).

Definition 2.1.4. [29, Chapter 32] A *star operation* on an integral domain R is a map $*$: $F(R) \rightarrow F(R)$ such that for any $I, J \in F(R)$ and $x \in K \setminus \{0\}$,

1. $I \subseteq I^*$.
2. $I \subseteq J$ implies $I^* \subseteq J^*$.
3. $(xI)^* = xI^*$.
4. $(I^*)^* = I^*$.
5. $R^* = R$.

Throughout this paper $\text{SStar}(R)$ (respectively, $\text{Star}(R)$) will denote the set of semistar operations on R (respectively, the set of star operations on R).

Example 2.1.5. [21, Example 1.3(a)] The following are standard examples of semistar operations:

1. The *identity operation* $d: \overline{F}(R) \rightarrow \overline{F}(R)$ defined by $I^d = I$ for all $I \in \overline{F}(R)$ is a semistar operation on R .
2. The *trivial operation* $e: \overline{F}(R) \rightarrow \overline{F}(R)$ defined by $I^e = K$ for all $I \in \overline{F}(R)$ is a semistar operation on R .
3. The *v-operation* $v: \overline{F}(R) \rightarrow \overline{F}(R)$ defined by $I^v = (R : (R : I))$ for all $I \in \overline{F}(R)$ is a semistar operation on R .
4. The *t-operation* $t: \overline{F}(R) \rightarrow \overline{F}(R)$ defined by $I^t = \bigcup \{J^v \mid J \subseteq I, J \in f\mathcal{S}(R)\}$ for all $I \in \overline{F}(R)$ is a semistar operation on R .
5. The *w-operation* $w: \overline{F}(R) \rightarrow \overline{F}(R)$ defined by $I^w = \bigcup \{(I : J) \mid J \in f\mathcal{S}(R), J^v = R\}$ for all $I \in \overline{F}(R)$ is a semistar operation on R .
6. *the extension to an overring T of R* , the operation $*_T: \overline{F}(R) \rightarrow \overline{F}(R)$ defined by $I^{*_T} = IT$ for all $I \in \overline{F}(R)$ is a semistar operation on R .
7. Given semistar operations $\{*_\alpha\}_{\alpha \in A}$ on R , the operation $\bigwedge_{\alpha \in A} *_\alpha$ defined by $I^{\bigwedge_{\alpha \in A} *_\alpha} =$

$\cap\{I^{*\alpha} \mid \alpha \in A\}$ for all $I \in \overline{F}(R)$ is a semistar operation on R .

8. ([68, Proposition 1.6]) Given an overring T of R and a semistar operation $*$ on T , $*^\iota: \overline{F}(R) \rightarrow \overline{F}(R)$ defined by $L^{*\iota} = (LT)^*$ for each $L \in \overline{F}(R)$ is a semistar operation on R .

9. ([68, Proposition 1.6]) Given an overring T of R and a semistar operation $*$ on R , $*_\iota: \overline{F}(T) \rightarrow \overline{F}(T)$ defined by $L^{*\iota} = L^*$ for each $L \in \overline{F}(T)$ is a semistar operation on T .

10. ([69, Proposition 1.17]) Given $I \in \overline{F}(R)$, $v(I): \overline{F}(R) \rightarrow \overline{F}(R)$ defined by $L^{v(I)} = I : (I : L)$ for each $L \in \overline{F}(R)$ is a semistar operation on R .

We say a semistar operation $*$ on a domain R is *stable* if $(I \cap J)^* = I^* \cap J^*$ for all $I, J \in \overline{F}(R)$. Given a semistar operation $*$ on R , define $*_f$ such that $I^{*f} = \bigcup\{J^* \mid J \subseteq I, J \in f(R)\}$ for all $I \in \overline{F}(R)$. Then $*_f$ is a semistar operation on R , and we say $*$ is *of finite type* if $* = *_f$. Every localizing system \mathcal{F} on a domain R yields a stable semistar operation $*_{\mathcal{F}}$, given as follows ([21, Proposition 2.4]): If $I \in \overline{F}(R)$, then

$$I^{*\mathcal{F}} = \bigcup_{J \in \mathcal{F}} (I : J).$$

On the other hand, given a semistar operation $*$ on R , the set $\mathcal{F}^* = \{I \in \mathcal{S}(R) \mid I^* = R^*\}$ is a localizing system of R ([21, Proposition 2.8], [21, Remark 2.9]). We adopt the notation $\overline{*}$ for the semistar operation $*_{\mathcal{F}^*}$ and $\widetilde{*}$ for the semistar operation $\overline{*}_f$. That is, $I^{\overline{*}} = \bigcup\{(I : J) \mid J \in \mathcal{S}(R), J^* = R^*\}$, $I^{\widetilde{*}} = \bigcup\{(I : J) \mid J \in \mathcal{S}(R), J^{*f} = R^*\}$ for all $I \in \overline{F}(R)$ (cf.[22, Section 3]).

The theorem below gives a relationship between localizing systems of finite type and semistar operations of finite type.

Theorem 2.1.6. [21, Proposition 3.2] *Let \mathcal{F} be a localizing system and $*$ a semistar operation defined on R .*

1. If \mathcal{F} is of finite type, then $*_{\mathcal{F}}$ is of finite type.
2. If $*$ is of finite type, then \mathcal{F}^* is of finite type.

Lemma 2.1.7. [21, Proposition 3.7.(2)] *If $*$ is a semistar operation, then $\overline{\mathcal{F}^*} = \mathcal{F}^*$.*

Given two semistar operations $*_1, *_2$, we write $*_1 \leq *_2$ if $I^{*1} \subseteq I^{*2}$ for all $I \in \overline{F}(R)$. We say $*_1 < *_2$ if $*_1 \leq *_2$ and $*_1 \neq *_2$. The following lemmas will be frequently used throughout this thesis.

Lemma 2.1.8. [21, Proposition 1.6] *Let $*_1, *_2$ be semistar operations on R . Then*

(a) $*_1 \leq *_2$ implies $(*_1)_f \leq (*_2)_f$ and $\overline{*_1} \leq \overline{*_2}$.

(b) $((*_1)_f)_f = (*_1)_f$ and $\overline{\overline{*_1}} = \overline{*_1}$.

(c) *The following are equivalent.*

1. $*_1 \leq *_2$.
2. $(I^{*1})^{*2} = I^{*2}$ for all $I \in \overline{F}(R)$.
3. $(I^{*2})^{*1} = I^{*2}$ for all $I \in \overline{F}(R)$.

Lemma 2.1.9. [69, Lemma 1.18, Propositions 1.17 and 1.20] *Let $I \in \overline{F}(R)$. If $v(I)$ is the semistar operation defined in Example 2.1.5.10, then*

1. $I^{v(I)} = I$.
2. *Given a semistar operation $*$ on R , $* \leq v(I)$ if and only if $I^* = I$.*

Lemma 2.1.10. *Let $*$ be a semistar operation on R and \mathcal{F} a localizing system on R .*

Then

1. $\overline{*} \leq *$ and $\mathcal{F}^{*\mathcal{F}} = \mathcal{F}$.
2. $*$ is stable if and only if $\overline{\overline{*}} = *$.
3. $*_f \leq *$, and if $*'$ is a finite semistar operation such that $*' \leq *$, then $*' \leq *_f$. Hence $*_f$ is the largest semistar operation of finite type dominated by $*$.

4. $\bar{*} \leq *$, and if $*'$ is a stable semistar operation such that $*' \leq *$, then $*' \leq \bar{*}$. Therefore $\bar{*}$ is the largest stable semistar operation dominated by $*$.

5. $*$ is finite and stable if and only if $* = \tilde{*}$.

Proof. 1 and 2 follow from [21, Theorem 2.10].

3. If $*'$ is a semistar operation of finite type on R and $*' \leq *$, then $*' = (*')_f \leq *_f$ by Lemma 2.1.8(a).

4 and 5 are direct consequences of [21, Proposition 3.7(1)] and [21, Corollary 3.9(2)], respectively. \square

Lemma 2.1.11. *Let R be a domain and S a multiplicatively closed subset of $f\mathcal{S}(R)$.*

Then if \mathcal{F}_S is as in Lemma 2.1.2, then for any $I \in \overline{F}(R)$,

$$I^{*\mathcal{F}_S} = \bigcup_{J \in \mathcal{F}_S} (I : J) = \bigcup_{L \in S} (I : L).$$

Proof. Since \mathcal{F}_S is a localizing system, the first equality is by definition of $*_{\mathcal{F}_S}$. We now prove the second equality holds. Let $I \in \overline{F}(R)$. Then since $S \subseteq \mathcal{F}_S$, obviously

$$\cup_{L \in S} (I : L) \subseteq \cup_{J \in \mathcal{F}_S} (I : J).$$

Conversely, if $J \in \mathcal{F}_S$, then there exists $L' \in S$ with $L' \subseteq J$. Thus $(I : J) \subseteq (I : L') \subseteq \cup_{L \in S} (I : L)$, and since this is true for every $J \in \mathcal{F}_S$, we have $\cup_{J \in \mathcal{F}_S} (I : J) \subseteq \cup_{L \in S} (I : L)$. \square

Corollary 2.1.12. *Given a semistar operation $*$, define $S^* = \{J \in f\mathcal{S}(R) \mid J^* = R^*\}$.*

Then

1. S^* is multiplicatively closed.
2. If $*$ is a semistar operation, then $I^{\tilde{*}} = \cup\{I : J \mid J \in S^*\}$.
3. $\tilde{*} = d$ if and only if $S^* = \{R\}$.

Proof. 1. Note that $S^* = \{J \in \mathcal{F}^* \mid J \in f\mathcal{S}(R)\}$. Clearly $R \in S^*$, and given $I, J \in S^*$, $IJ \in f\mathcal{S}(R)$ and $(IJ)^* = (I^*J^*)^* = (R^*R^*)^* = R^*$, so $IJ \in S^*$ and S^* is multiplicatively closed.

2. Since $S^* = f\mathcal{S}(R) \cap \mathcal{F}^*$, it follows that $\mathcal{F}_{S^*} = \mathcal{F}^{*f}$. Thus by Lemma 2.1.11, the statement is proved.

3. \Rightarrow : If $\tilde{*} = d$, then by part 2, for any $I \in \mathcal{F}(R)$ and $J \in S^*$, $I \subseteq I : J \subseteq \cup\{I : L \mid L \in S^*\} = I^{\tilde{*}} = I$, so $I = I : J$. In particular, $J = J : J \supset R$, so $J = R$. Hence $S^* = \{R\}$.

\Leftarrow : If $S^* = \{R\}$, then by part 2, $I^{\tilde{*}} = \cup\{I : L \mid L \in S^*\} = I : R = I$ for any $I \in \mathcal{F}(R)$, so $\tilde{*} = d$. □

Corollary 2.1.13. *Let $*_1, \dots, *_n$ be semistar operations of finite type and stable on R . Then $* = \wedge_{i=1}^n *_i$ is a semistar operation of finite type and stable on R .*

Proof. By induction, we may assume that $n = 2$. To show that $*$ is stable, note that $(I \cap J)^* = (I \cap J)^{*1} \cap (I \cap J)^{*2} = I^{*1} \cap J^{*1} \cap I^{*2} \cap J^{*2} = I^* \cap J^*$ for each $I, J \in \overline{F}(R)$. On the other hand, if $x \in I^*$, then there exist $J_1, J_2 \in f(R)$ such that $x \in J_i^{*i}$ and $J_i \subset I$ for $i = 1, 2$. Let $J = J_1 + J_2$. Then $J \in f(R)$ and $x \in J^*$, so $x \in I^{*f}$. Thus $* = *^f$ and $*$ is of finite type. □

We say a semistar operation $*$ is *spectral semistar operation associated with Δ* if there exists $\Delta \subseteq \text{Spec}(R)$ such that $I^* = \cap\{IR_P \mid P \in \Delta\}$ for all $I \in \overline{F}(R)$.

Lemma 2.1.14. *If $*$ is stable and of finite type, then $*$ is spectral. In this case, $I^* = \cap\{IR_P \mid P \in \Delta\}$ for all $I \in \overline{F}(R)$, where Δ is the set of maximal elements of $\{I \in \mathcal{S}(R) \mid I^* \cap R = I \subseteq R, I^* \subsetneq R^*\}$. From now on such Δ will be denoted by $*\text{Max}(R)$. Moreover, if $P \in *\text{Max}(R)$ and $P \subsetneq Q$, then $Q^* = R^*$.*

Proof. Follows from [21, Theorem 4.12], [21, Corollary 4.21] and [21, Remark 4.22]. □

2.2 $*$ -cancellation ideals and $*$ -invertible ideals

Definition 2.2.1. Let $*$ be a semistar operation on R . A fractional ideal J of R is said to be a $*$ -cancellation ideal if $(JL_1)^* = (JL_2)^*$ implies $L_1^* = L_2^*$ for any $L_i \in \overline{F}(R)$. If $*$ = d , then we use the term *cancellation ideal* instead of d -cancellation ideal. We say J is a $*$ -invertible ideal if $(JJ^{-1})^* = R^*$. Again, we will use the term invertible ideals for d -invertible ideals.

Let us begin with an elementary lemma.

Lemma 2.2.2. Let $*, *_1, *_2$ be semistar operations on R . Then

1. Every $*$ -invertible ideal is a $*$ -cancellation ideal.
2. If $*_1 \leq *_2$, then every $*_1$ -invertible ideal is a $*_2$ -invertible ideal.

Proof. 1. If I is a $*$ -invertible ideal, then we have

$$\begin{aligned}
 (IJ)^* &= (IL)^* \\
 \Rightarrow (IJ)^*(I^{-1})^* &= (IL)^*(I^{-1})^* \\
 \Rightarrow ((IJ)^*(I^{-1})^*)^* &= ((IL)^*(I^{-1})^*)^* \\
 \Rightarrow (J(II^{-1})^*)^* &= (L(II^{-1})^*)^* \\
 \Rightarrow (JR^*)^* &= (LR^*)^* \\
 \Rightarrow J^* &= L^*. \text{ Hence } I \text{ is a } * \text{-cancellation ideal.}
 \end{aligned}$$

2. If I is a $*_1$ -invertible ideal, then by Lemma 2.1.8,

$$\begin{aligned}
 (II^{-1})^{*1} &= R^{*1} \\
 \Rightarrow ((II^{-1})^{*1})^{*2} &= (R^{*1})^{*2} \\
 \Rightarrow (II^{-1})^{*2} &= R^{*2}.
 \end{aligned}$$

Thus I is $*_2$ -invertible. □

Lemma 2.2.3. [1, Lemma 1] Let $*$ be a semistar operation on R . TFAE.

1. J is a $*$ -cancellation ideal.
2. $I^* = (IJ)^* : J$ for all $I \in \overline{F}(R)$.
3. $(JI_1)^* \subseteq (JI_2)^*$ implies $I_1^* \subseteq I_2^*$ for every $I_1, I_2 \in \overline{F}(R)$.

Lemma 2.2.4. 1. Let $I \in \overline{F}(R)$, $J \in f(R)$ and $*$ a stable semistar operation on R .

Then $(I : J)^* = I^* : J^* = I^* : J$.

2. Let $J \in f(R)$ and $*_1, *_2$ semistar operations on R such that $*_1 \leq *_2$ and $*_2$ is stable.

If J is $*_1$ -cancellation ideal, then J is also a $*_2$ -cancellation ideal.

Proof. 1. Let $J = j_1R + \cdots + j_nR$. Then

$(I : J)^* = (I : \sum_{r=1}^n j_r R)^* = (\cap_{r=1}^n (I : j_r))^* = (\cap_{r=1}^n I j_r^{-1})^* = \cap_{r=1}^n (I j_r^{-1})^* = \cap_{r=1}^n (I^* j_r^{-1}) = \cap_{r=1}^n (I^* : j_r) = (I^* : \sum_{r=1}^n j_r) = (I^* : J)$. It remains to show that $I^* : J = I^* : J^*$. Since $J \subseteq J^*$, $I^* : J^* \subseteq I^* : J$. On the other hand, if $x \in I^* : J$, then $xJ \subseteq I^* \Rightarrow xJ^* = (xJ)^* \subseteq (I^*)^* = I^*$, so $x \in I^* : J^*$. Therefore $I^* : J = I^* : J^*$, and we are done.

2. Let J be a $*_1$ -cancellation ideal. Then $I^{*1} = (IJ)^{*1} : J$ for all $I \in \mathcal{S}(R)$ by Lemma 2.2.3. Now by part 1, $I^{*2} = (I^{*1})^{*2} = ((IJ)^{*1} : J)^{*2} = ((IJ)^{*1})^{*2} : J = (IJ)^{*2} : J$, for all $I \in \mathcal{S}(R)$, so again by Lemma 2.2.3, J is a $*_2$ -cancellation ideal. \square

Corollary 2.2.5. Let $I \in \overline{F}(R)$, $J \in f(R)$, and S a multiplicatively closed subset of R .

Then

1. $(I : J)R_S = IR_S : JR_S$.
2. Let $*$ be a spectral semistar operation associated with Δ and J a $*$ -cancellation ideal.

Then JR_M is a (finitely generated) cancellation ideal of R_M for each $M \in \Delta$.

Proof. 1. Define the map $*_{R_S} : \overline{F}(R) \rightarrow \overline{F}(R)$ by $I \mapsto IR_S$ for all $I \in \overline{F}(R)$. Then $*_{R_S}$ is a stable semistar operation, so it is just a consequence of Lemma 2.2.4.1.

2. Suppose that J is a $*$ -cancellation ideal. Then since $*$ \leq $*_{R_M}$, by Lemma 2.2.4 J is a $*_{R_M}$ -cancellation ideal and $JR_M = IJR_M : J$ for all $I \in \mathcal{S}(R)$. Hence JR_M is a cancellation ideal of R_M . \square

Lemma 2.2.6. *Let R be a quasilocal domain and $I \in f\mathcal{S}(R)$. Then TFAE.*

1. I is a principal ideal.
2. I is an invertible ideal.
3. I is a cancellation ideal.

Proof. 1 \Rightarrow 2 \Rightarrow 3: Trivial.

3 \Rightarrow 1: See [30, 13.8]. \square

Lemma 2.2.7. *Let $*$ be a spectral semistar operation associated with Δ and $I \in f(R)$.*

Then I is a $$ -invertible ideal if and only if I is a $*$ -cancellation ideal.*

Proof. By Lemma 2.2.2, every $*$ -invertible ideal is a $*$ -cancellation ideal.

Conversely, let I be a $*$ -cancellation ideal and choose $M \in \Delta$. Then by Corollary 2.2.5.2,

IR_M is a cancellation ideal of R_M , and by Lemma 2.2.6, IR_M is invertible in R_M and

so $IR_M(R_M : IR_M) = R_M$. By Corollary 2.2.5.1, $I^{-1}R_M = (R : I)R_M = R_M : IR_M$.

Therefore, we have $(II^{-1})R_M = IR_M I^{-1}R_M = IR_M(R_M : IR_M) = R_M$.

Now $(II^{-1})^* = \cap\{(II^{-1})R_M \mid M \in \Delta\} = \cap\{R_M \mid M \in \Delta\} = R^*$, so I is $*$ -invertible. \square

Lemma 2.2.8. [29, Corollary 6.4(b)] *If $I \in \mathcal{S}(R)$, $J \in f\mathcal{S}(R)$ are nonzero and $IJ = J$,*

then $I = R$.

Lemma 2.2.9. *Let Δ be a nonempty subset of prime ideals of R and $*$ a spectral*

semistar operation associated with Δ . If $I \in \mathcal{S}(R)$, $J \in f\mathcal{S}(R)$ and $(IJ)^ = J^*$, then*

$I^ = R^*$.*

Proof. Fix $M \in \Delta$. Since $* \leq *_{R_M}$, $(IJ)^* = J^*$ implies $IR_MJR_M = IJR_M = JR_M$, and by Lemma 2.2.8 $IR_M = R_M$. Hence $I^* = \cap\{IR_M \mid M \in \Delta\} = \cap\{R_M \mid M \in \Delta\} = R^*$. □

Chapter 3

When is there a semistar operation that properly sits between two semistar operations?

Let us begin with the following lemma and its corollary.

Lemma 3.0.1. *Let $L \in f(R)$ and $\{J_\alpha\}_{\alpha \in A}$ a directed set under inclusion (i.e., given $\alpha, \beta \in A$, there exists $\gamma \in A$ so $J_\alpha \subseteq J_\gamma$ and $J_\beta \subseteq J_\gamma$). If $L \subseteq \cup\{J_\alpha \mid \alpha \in A\}$ then $L \subseteq J_\gamma$ for some $\gamma \in A$.*

Proof. Let $L = l_1R + \cdots + l_nR$. If $L \subseteq \cup\{J_\alpha \mid \alpha \in A\}$, then $l_i \in \cup\{J_\alpha \mid \alpha \in A\}$ for each i , so there exists $\alpha_1, \dots, \alpha_n \in A$ such that $l_i \in J_{\alpha_i}$. Now since $\{J_\alpha\}_{\alpha \in A}$ is directed, by induction there exists $\gamma \in A$ such that $J_{\alpha_i} \subseteq J_\gamma$ for all $i \in \{1, 2, \dots, n\}$. Hence $L \subseteq J_\gamma$. □

Corollary 3.0.2. *Let $L \in f(R), I \in \overline{F}(R)$, S a multiplicatively closed subset of $\mathcal{S}(R)$ and $*$: $\overline{F}(R) \rightarrow \overline{F}(R)$ such that $I_1 \subseteq I_2$ implies $(I_1)^* \subseteq (I_2)^*$ for all $I_1, I_2 \in \overline{F}(R)$.*

Then

1. If $L \subseteq \{H^* \mid H \subseteq I, H \in f(R)\}$, then $L \subseteq H^*$ for some $H \subseteq I, H \in f(R)$.
2. If $L \subseteq \{I : J \mid J \in S\}$, then $LJ \subseteq I$ for some $J \in S$.

Proof. By Lemma 3.0.1 it suffices to show that both $\{H^* \mid H \subseteq I, H \in f(R)\}$ and $\{I : J \mid J \in S\}$ are directed under inclusion.

1. Given $H_1, H_2 \in f(R)$ with $H_1 \subseteq I$, set $H = H_1 + H_2$. Then $H \subseteq I, H \in f(R)$ and $H_1^* \subseteq H^*, H_2^* \subseteq H^*$. Thus $\{H^* \mid H \subseteq I, H \in f(R)\}$ is a directed set under inclusion.
2. Given $J_1, J_2 \in S, J_1J_2 \in S$ since S is multiplicatively closed. Also, since $J_1J_2 \subseteq J_i$ for $i = 1, 2$, we have $I : J_1 \subseteq I : J_1J_2$ and $I : J_2 \subseteq I : J_1J_2$, so $\{I : J \mid J \in \mathcal{F}^{*2}\}$ is a directed set under inclusion. □

The following generalizes [24, Proposition 4.5].

Lemma 3.0.3. *Given a semistar operation $*$ on R and a multiplicatively closed subset*

*S of $\overline{F}(R)$, let $*_S : \overline{F}(R) \rightarrow \overline{F}(R)$ be the function defined by*

*$H^{*s} = \cup\{(HJ)^* \mid J \in S\}$ for each $H \in f(R)$, and*

*$I^{*s} = \cup\{H^{*s} \mid H \subseteq I, H \in f(R)\}$ for each $I \in \overline{F}(R)$. Then*

1. $*_S$ is a semistar operation of finite type.
2. If $*$ is a semistar operation of finite type on R and $S \subseteq f(R)$, then $I^{*s} = \cup\{(IJ)^* \mid J \in S\}$ for each $I \in \overline{F}(R)$.

Proof. 1. Note that if $*_S$ is a semistar operation on R , then it must be of finite type by definition. Thus we only need to show that $*_S$ is a semistar operation on R .

Let $I, I_1, I_2 \in \overline{F}(R)$. If $x \in I$, then for any $J \in S, xJ \subseteq xJ^* = (xJ)^*$ and $x \in (xJ)^* : J \subseteq \cup\{H^{*s} \mid H \subseteq I, H \in f(R)\} = I^{*s}$. Hence $I \subseteq I^{*s}$.

Secondly, assume $I_1 \subseteq I_2$. Then for each $x \in (I_1)^{*s}$, there exists $H \in f(R)$ such that $H \subseteq I_1 \subseteq I_2$ and $x \in H^{*s}$, so $x \in (I_2)^{*s}$ and $(I_1)^{*s} \subseteq (I_2)^{*s}$.

Thirdly, for any $x \in K - \{0\}$ and $H \in f(R)$, $(xH)^{*s} = \cup\{(xHJ)^* : J \mid J \in S\} = \cup\{x(HJ)^* : J \mid J \in S\} = \cup\{x((HJ)^* : J) \mid J \in S\} = x(\cup\{(HJ)^* : J \mid J \in S\}) = xH^{*s}$. Hence $(xI)^{*s} = \cup\{H^{*s} \mid H \subseteq xI, H \in f(R)\} = \cup\{x(x^{-1}H)^{*s} \mid x^{-1}H \subseteq I, H \in f(R)\} = x(\cup\{(H')^{*s} \mid H' \subseteq I, H' \in f(R)\}) = xI^{*s}$.

Finally, it remains to show that $(I^{*s})^{*s} = I^{*s}$. Let $x \in (I^{*s})^{*s}$, then $x \in H^{*s}$ for some $H \subseteq I^{*s}, H \in f(R)$. Hence $x \in \cup\{(HJ)^* : J \mid J \in S\}$ and $x \in (HJ)^* : J$ for some $J \in S$, so $xJ \subseteq (HJ)^*$. On the other hand, since $H \subseteq I^{*s} = \cup\{(H')^{*s} \mid H' \subseteq I, H' \in f(R)\}$, by Corollary 3.0.2 $H \subseteq (H')^{*s}$ for some $H' \subseteq I, H' \in f(R)$. Similarly, since $(H')^{*s} = \cup\{(H'J')^* : J' \mid J' \in S\}$, again by Corollary 3.0.2 $H \subseteq (H'J')^* : J'$ and $HJ' \subseteq (H'J')^*$ for some $J' \in S$. Thus $xJJ' \subseteq (HJ)^*J' \subseteq (HJ'J)^* \subseteq ((H'J')^*J)^* = (H'J'J)^*$, and $x \in (H'J'J)^* : JJ' \subseteq (H')^{*s} \subseteq I^{*s}$. Thus $(I^{*s})^{*s} \subseteq I^{*s}$. Therefore $*_S$ is a semistar operation.

2. Clearly $I^{*s} \subseteq \cup\{(IJ)^* : J \mid J \in S\}$ for each $I \in \overline{F}(R)$, even if $*$ is not of finite type. Suppose that $*$ is of finite type and choose $I \in \overline{F}(R)$. If $x \in \cup\{(IJ)^* : J \mid J \in S\}$, then $x \in (IJ)^* : J$ for some $J \in S$ and $xJ \subseteq (IJ)^*$. Now since $*$ is of finite type, $xJ \subseteq L^*$ for some $L \in f(R)$ with $L \subseteq IJ$ by Corollary 3.0.2. Now let $L = l_1R + \dots + l_nR$, and given $r \in \{1, \dots, n\}$, there exists a finite set A_r and elements $i_k \in I, j_k \in J$ for each $k \in A_r$ such that $l_r = \sum_{k \in A_r} i_k j_k$. Now set $A = \cup_{r=1}^n A_r$ and set $H = \sum_{k \in A} i_k R$. Then $H \in f(R)$, $H \subseteq I$ and $L \subseteq HJ \subseteq IJ$. Hence $xJ \subseteq (HJ)^*$ and $x \in (HJ)^* : J \subseteq I^{*s}$. \square

Lemma 3.0.4. *Let $*$ be a semistar operation of finite type and S a multiplicatively closed subset of $f(R)$. Then*

1. $* \leq *_S$, and the equality holds if and only if every element of S is a $*$ -cancellation ideal.

2. $\bar{*} = \overline{*}_S$.

3. $*_{S^*} = *$.

Proof. Note that by Lemma 3.0.3, $I^{*S} = \cup\{(IJ)^* : J \in S\}$ for each $I \in \overline{F}(R)$.

1. Since given $I \in \overline{F}(R)$, $I^* \subseteq (IJ)^* : J$ for any $J \in \overline{F}(R)$, we have $I^* \subseteq I^{*S}$. Hence $* \leq *_S$. For the second assertion, fix $I \in \overline{F}(R)$. Suppose that $I^{*S} = I^*$. Then for any $J_0 \in S$, we have $I^* \subseteq (IJ_0)^* : J_0 \subseteq \cup\{(IJ)^* : J \in S\} = I^{*S} = I^*$, so $I^* = (IJ_0)^* : J_0$. Hence by Lemma 2.2.3, J_0 is a $*$ -cancellation ideal. Conversely, if every element of S is $*$ -cancellation ideal, then again by Lemma 2.2.3, $I^* = (IJ)^* : J$ for all $J \in S$ and $I \in \mathcal{F}(R)$, and $I^* = I^{*S}$. So $* = *_S$.

2. Let $I \in \mathcal{F}^{*S}$. Then since $*_S$ is of finite type by Lemma 3.0.3, \mathcal{F}^{*S} is a localizing system of finite type by Lemma 2.1.6. Now for each $M \in S^{*S}$, we have $R \subseteq R^{*S} = M^{*S} = \cup\{(MJ)^* : J \in S\}$, so $1 \in \cup\{(MJ)^* : J \in S\}$ and $J \subset (MJ)^* \Rightarrow J^* = (MJ)^*$, so again by Lemma 2.2.9 $M^* = R^*$. Hence by Lemma 2.1.10.2 and Corollary 2.1.12, $\overline{I^{*S}} = \cup\{I : M \mid M \in S^{*S}\} \subseteq \cup\{I : M \mid M \in S^*\} = \overline{I^*}$ for each $I \in \overline{F}(R)$. and $\overline{*}_S \leq \bar{*}$. Since $* \leq *_S$ we have $\bar{*} \leq \overline{*}_S$ by Lemma 2.1.8(a). Thus $\bar{*} = \overline{*}_S$.

3. Choose $I \in \overline{F}(R)$. Then $I^{*S^*} = \cup\{(IJ)^* : J \in S^*\} = \cup\{(IJ^*)^* : J \in S^*\} = \cup\{(IR^*)^* : J \in S^*\} = \cup\{I^* : J \in S^*\} = (I^*)^{\tilde{*}} = I^*$ by Lemma 2.1.8(c) and Corollary 2.1.12. □

Now we are ready for the main theorem and its proof.

Theorem 3.0.5. *Let $*_1, *_2$ be semistar operations on R and assume that $*_1$ is of finite type and $*_2$ is stable. Set $* = (*_1)_{S^{*_2}}$.*

(a) $*_1 \leq * \leq *_1*_2$.

(b) *Suppose that $*_1$ is stable. Then*

1. *If $*_1 \neq *_1*_2$, then $* < *_1*_2$.*

2. If $*_1 \neq *_1*_2$, $*_2$ is of finite type and there exists $I \in f(R)$ such that $I^{*2} \subseteq I^{*1}$, then $*_1 < *$.

3. $*$ is stable if and only if $* = *_1$.

Proof. (a) $*_1 \leq *$ follows from Lemma 3.0.4. On the other hand, $(IJ)^* : J \subseteq I^* : J$ for each $J \in S^{*2}$, so $I^* \subseteq \cup\{I^{*1} : J \mid J \in S^{*2}\} = I^{*1*2}$. Hence $I^{*1} \subseteq I^* \subseteq I^{*1*2}$ for all $I \in \overline{F}(R)$ and the statement follows.

(b) Now suppose that $*_1 < *_1*_2$. Then there exists an ideal L such that $L^{*2} = R^{*2}$ and $L^{*1} \subsetneq R^{*1}$ (otherwise, $\mathcal{F}^{*2} \subseteq \mathcal{F}^{*1}$ and $*_2 = \overline{*}_2 \leq \overline{*}_1 \leq *_1$, so $*_1*_2 = *_1$, which is a contradiction). Note also that $1 \in R^{*2} \subseteq L^{*1*2}$.

1. Assume that $* = *_1*_2$. Then $L^* = L^{*1*2} \Rightarrow 1 \in L^* \Rightarrow 1 \in \cup\{(IJ)^{*1} : J \mid J \in S^{*2}\} \Rightarrow 1 \in (IJ)^{*1} : J$ for some $J \in S^{*2} \Rightarrow J \subseteq (IJ)^{*1}$ for some $J \in S^{*2} \Rightarrow J^{*1} = (IJ)^{*1}$. Since $*_1$ is spectral by Lemma 2.1.14, we have $I^{*1} = R^{*1}$ by Lemma 2.2.9, which is a contradiction. Thus $* < *_1*_2$.

2. Assume that given conditions hold. Then $(I^{*2})^{*1} \subseteq (I^{*1})^{*1} = I^{*1}$, and by Lemma 4.1.3, $(I^{*1})^{*2} = (I^{*2})^{*1} = I^{*1}$. Since $*_2$ is stable and finite, this means $I^{*1} = \cup\{I^{*1} : L \mid L \in S^{*2}\}$, and $I^{*1} = I^{*1} : L$ for all $L \in S^{*2}$. Since $I \subseteq I : L$, we must have $I^{*1} \subseteq (I : L)^{*1} \subseteq I^{*1} : L$ and thereby $I^{*1} = (I : L)^{*1}$. Now suppose that $*_1 = *$. Then by Lemma 3.0.4.1, every element of S^{*2} is $*_1$ -invertible, so L is $*_1$ -invertible and $I^{*1} = (IR^{*1})^{*1} = (I((R : L)L)^{*1})^{*1} \subseteq ((I : L)L)^{*1} = ((I : L)^{*1}L)^{*1} = (I^{*1}L)^{*1} = (IL)^{*1}$ ([21, Theorem 1.2(3)]). Since $(IL)^{*1} \subseteq (IR)^{*1} = I^{*1}$, we have $(IL)^{*1} = I^{*1}$ and $L^{*1} = R^{*1}$ by Lemma 2.2.9. Hence $L \in S^{*1}$. But then $*_2 = \widetilde{*}_2 \leq \widetilde{*}_1 = *_1$ by Corollary 2.1.12 and Lemma 2.1.10.5, so $*_1 = *_1*_2$, which is a contradiction. Thus $*_1 < *$.

3. Just a corollary of Lemma 3.0.4.2. □

Theorem 3.0.5 gets neater under a certain restriction.

Corollary 3.0.6. *Let $*_1 \leq *_2$ be semistar operations of finite type and stable and set $* = (*_1)_{\mathcal{S}^{*_2}}$. Then*

1. $*_1 \leq * \leq *_2$.
2. *If $*_1 < *_2$ and $I^{*2} = I^{*1}$ for some $I \in f(R)$, then $*_1 < * < *_2$, and $*$ is a nonstable semistar operation of finite type.*

The following corollary of Theorem 3.0.5 yields a new semistar operation.

Corollary 3.0.7. *Let $* = d_{GV(R)}$, where $GV(R) = \{I \in f\mathcal{S}(R) \mid I^v = R\}$ is the set of Glaz-Vasconcelos ideals of R ([75]). Then $d \leq * \leq w$. If $d \neq w$, then $d < * < w$ and $*$ is a nonstable semistar operation of finite type.*

Proof. Note that d and w are finite and stable with $R^w = R^d = R \in f(R)$. Now it is just a special case of Corollary 3.0.6. □

Chapter 4

On the composition and partial ordering of the set of semistar operations

4.1 Composition of two semistar operations

Given two semistar operations $*_1, *_2$ of R , we can think of the map $*_1*_2 : \overline{F}(R) \rightarrow \overline{F}(R)$ defined by $I^{*_1*_2} = (I^{*_1})^{*_2}$ for each $I \in \overline{F}(R)$. In general, this map is not a semistar operation on R ([68, Example 2.1.(1)]), but we will show that under a certain restriction it is.

Lemma 4.1.1. *[68, Proposition 2.5] Let $*_1$ be semistar operation on R and $*_2$ a semistar operation on T , where T is an integral domain such that $R \subseteq T \subseteq R^{*1}$. Then $*_1*_2$ is a semistar operation on R if and only if $I^{*2*1} \subseteq I^{*_1*_2}$ for all $I \in \overline{F}(T)$.*

Lemma 4.1.2. *Let $*_1$ be semistar operation of finite type on R and $*_2$ be a stable semistar operation on T , where T is an integral domain such that $R \subseteq T \subseteq R^{*1}$. Then $*_1*_2$ is a semistar operation on R .*

Proof. Pick $I \in \overline{F}(T)$. Choose $x \in K - \{0\}$ such that $x \in (I^{*2})^{*1}$. Then since $*_1$ is of finite type, there exists $N \in f(R)$ such that $N \subseteq I^{*2}$ and $x \in N^{*1}$. On the other hand, since $*_2$ is stable, we have $I^{*2} = \cup\{I : J \mid J \in \mathcal{F}^{*2}\}$. By Corollary 3.0.2 there exists $L \in \mathcal{F}^{*2}$ such that $NL \subseteq I$. Now $xL \subseteq N^{*1}L \subseteq (NL)^{*1} \subseteq I^{*1}$, and $x \in I^{*1} : L \subseteq \cup\{I^{*1} : J \mid J \in \mathcal{F}^{*2}\} = (I^{*1})^{*2}$. Hence we have shown that $I^{*2*1} \subseteq I^{*1*2}$. Now by Lemma 4.1.1, $*_1*_2$ is a semistar operation on R . \square

Picozza proves that when both $*_1$ and $*_2$ are stable and of finite type, then $*_1*_2$ is stable and of finite type if $*_1*_2$ is a semistar operation ([68, Proposition 2.7 (3) and (4)]). The next lemma shows that the assumption that $*_1*_2$ is a semistar operation is unnecessary.

Lemma 4.1.3. *1. Let $*_1, *_2$ be semistar operations on R . If both $*_1$ and $*_2$ are stable and of finite type, then*

(a) $*_1*_2 = *_2*_1$ is a semistar operation on R .

(b) $*_1*_2$ is stable and of finite type.

2. The set of semistar operations on an integral domain R that is stable and of finite type forms a distributive lattice with $*_1 \vee *_2 = *_1*_2$.

Proof. 1. (a) Follows from Lemma 4.1.1 and Lemma 4.1.2.

1. (b) Note that since $*_1*_2$ is a semistar operation, S^{*1*_2} is a multiplicatively closed set and $S^{*1} \cup S^{*2} \subset S^{*1*_2}$. Hence $*_1 \leq \widetilde{*_1*_2}$ and $*_2 \leq \widetilde{*_1*_2}$ by Corollary 2.1.12. Thus $*_1*_2 \leq (\widetilde{*_1*_2})(\widetilde{*_1*_2}) = \widetilde{*_1*_2} \leq *_1*_2$. Therefore $*_1*_2 = \widetilde{*_1*_2}$ and $*_1*_2$ is finite and stable by Lemma 2.1.10.5.

2. Let Σ be the set of stable and of finite type semistar operations on an integral domain R . Note that Σ is partially ordered under \leq . Given $*_1, *_2 \in \Sigma$, define $*_1 \vee *_2 = *_1 *_2$. Then by (b), $*_1 \vee *_2 \in \Sigma$, $*_1 \leq *_1 \vee *_2$ and $*_2 \leq *_1 \vee *_2$. Moreover, if $* \in \Sigma$ such that $*_1 \leq *$ and $*_2 \leq *$, then $*_1 \vee *_2 = *_1 *_2 \leq ** = *$. Hence $*_1 \vee *_2$ is the supremum of $*_1$ and $*_2$.

On the other hand, $*_1 \wedge *_2$, as defined in Example 2.1.5.7, is an element of Σ by Corollary 2.1.13. The fact that $*_1 \wedge *_2$ is the infimum of $*_1$ and $*_2$ follows from definition. Hence Σ is a lattice. Finally, for each $I \in \overline{F}(R)$ and $*_i \in \Sigma$ for $i = 1, 2$ and 3 , $I^{*_1 \vee (*_2 \wedge *_3)} = I^{*_1 (*_2 \wedge *_3)} = (I^{*_1})^{*_2} \cap (I^{*_1})^{*_3} = I^{(*_1 *_2) \wedge (*_1 *_3)} = I^{(*_1 \vee *_2) \wedge (*_1 \vee *_3)}$, and $*_1 \vee (*_2 \wedge *_3) = (*_1 \vee *_2) \wedge (*_1 \vee *_3)$. Thus Σ is a distributive lattice. \square

We may now investigate some basic properties of a certain type of semistar operation induced by Lemma 4.1.2.

Lemma 4.1.4. *For each semistar operation $*$ on R , set $*_g = *_f \bar{*}$. Let $*, *_1, *_2$ be semistar operations on R . Then,*

(a) 1. $*_g$ is semistar operation on R .

2. $*_f \leq *_g \leq *$ and $\bar{*} \leq *_g \leq *$.

3. $*_1 \leq *_2$ implies $(*_1)_g \leq (*_2)_g$.

4. $(*_f)_g = (*_g)_f = *_f$, $(\bar{*})_g = \overline{*_g} = \bar{*}$ and $(*_g)_g = *_g$.

(b) The following are equivalent.

1. $*_g$ is stable.

2. $*_g = \bar{*}$.

3. $*_f \leq \bar{*}$.

4. $*_f = (\bar{*})_f$.

5. $*$ is finite stable (a semistar operation $*$ on R is finite stable if $(I \cap J)^* = I^* \cap J^*$)

for each $I, J \in f(R)$.

(c) The following are equivalent.

1. $*_g$ is of finite type.
2. $*_g = *_f$.
3. $\bar{*} \leq *_f$.
4. $\bar{*} = \tilde{*}$.
5. $\bar{*}$ is of finite type.

Proof. (a) 1. Since $*_f$ is of finite type and $\bar{*}$ is stable, the conclusion follows from Lemma 4.1.2.

2. Note that $*_f \leq *$ and $\bar{*} \leq *$, so $*_f \leq *_f \bar{*} \leq ** = *$. Similarly $\bar{*} \leq *_f \bar{*} \leq ** = *$.

3. Suppose that $*_1 \leq *_2$. Then $(*_1)_f \leq (*_2)_f$ and $\bar{*}_1 \leq \bar{*}_2$, so $(*_1)_g = (*_1)_f \bar{*}_1 \leq (*_2)_f \bar{*}_2 = (*_2)_g$.

4. We have $(*_f)_g = (*_f)_f \bar{*}_f = *_f \tilde{*} = *_f$ and $*_f = (*_f)_f \leq (*_g)_f \leq *_f$ by Lemma 2.1.8, so the first equality follows. The second one follows similarly. On the other hand, Since $*_g \leq *$ for each semistar operation $*$ on R , we have $(*_g)_g \leq *_g$. On the other hand, $(*_g)_g = (*_g)_f \bar{*}_g = (*_f \bar{*})_f (\overline{*_f \bar{*}}) \geq (*_f)_f \bar{*} = *_f \bar{*} = *_g$. Therefore $(*_g)_g = *_g$.

(b) Note that $\bar{*} \leq *_g$ and $*_f \leq *_g$. Also, $*_g = *_f \bar{*} \leq ** = *$.

1 \Rightarrow 2: By Lemma 2.1.10, 1 implies 2.

2 \Rightarrow 3: Follows from Lemma 2.1.8(c).

3 \Rightarrow 4: If 3 is true, then by Lemma 2.1.8, $*_f = (*_f)_f \leq (\bar{*})_f \leq *_f$, so $*_f = (\bar{*})_f$.

4 \Rightarrow 5: Let $*$ be a semistar operation and $I, J \in f(R)$. Then $I^* \cap J^* = I^{*_f} \cap J^{*_f} = I^{(\bar{*})_f} \cap J^{(\bar{*})_f} = I^{\bar{*}} \cap J^{\bar{*}} = (I \cap J)^{\bar{*}} \subseteq (I \cap J)^* \subseteq I^* \cap J^*$. Hence $*$ is finite stable.

5 \Rightarrow 1: Let $*$ be finite stable. Then given $I \in f(R)$, choose $x \in I^*$ and set $J = (I : x) \cap R$.

Then J is an ideal of R , and $J^* = ((I : x) \cap R)^* = (x^{-1}I \cap R)^* = (x^{-1}I)^* \cap R^* = x^{-1}I^* \cap$

$R^* \supseteq R$, so $J^* = R^*$ and $J \in \mathcal{F}^*$. Now $xJ \subseteq I$, so $x \in I : J \subseteq \cup\{I : L \mid L \in \mathcal{F}^*\} = I^{\bar{*}}$.

Thus $I^* = I^{\bar{*}}$. Since I was arbitrary element of $f(R)$, it follows that $*_f = (\bar{*})_f$.

(c) 1 \Rightarrow 2: Since $*_f \leq *_g \leq *$, by Lemma 2.1.10, 1 implies 2.

2 \Rightarrow 3: Follows from Lemma 2.1.8(c).

3 \Rightarrow 4: If 3 is true, then by Lemma 2.1.8, $\bar{*} = \bar{*} \leq \bar{*}_f = \tilde{*} \leq \bar{*}$ and $\bar{*} = \tilde{*}$.

4 \Rightarrow 5: since $\tilde{*}$ is of finite type, 4 implies 5.

5 \Rightarrow 1: If 5 holds, then by Lemma 2.1.10, $\bar{*} \leq *_f$. Hence $*_g = *_f \bar{*} = *_f$, so $*_g$ is of finite type. □

Lemma 4.1.5. *If $*$ is a semistar operation of finite type, then $*$ is stable if and only if it is finite stable.*

Proof. Let $*$ be a semistar operation of finite type. Then $* = *_f$, so $*_g = (*_f)_g = *_f = *$ by Lemma 4.1.4(a).4. Therefore the conclusion follows from Lemma 4.1.4.(b). □

Lemma 4.1.6. *Let $*$ be a semistar operation on R . Let $*_h = *_f \wedge \bar{*}$ (that is, $I^{*h} = I^{*f} \cap I^{\bar{*}}$ for each $I \in \bar{F}(R)$). Then $\bar{*}_h = \bar{*}_f$ and $(*_h)_f = (\bar{*})_f$. In particular, $(*_h)_g = (\bar{*})_f$.*

Proof. For the first assertion, it suffices to show that $\mathcal{F}^{*h} = \mathcal{F}^{*f}$. Let $I \in \mathcal{F}^{\bar{*}_f} = \mathcal{F}^{*f}$. Then $I^{*f} = R^{*f}$, so $I^* = R^*$ and $I^{\bar{*}} = R^{\bar{*}}$, so $I^{*h} = R^{*h}$. Thus $\mathcal{F}^{*f} \subseteq \mathcal{F}^{*h}$. Since $*_h \leq *_f$, we have $\mathcal{F}^{*h} \subseteq \mathcal{F}^{*f}$.

Now consider the second assertion. If $I \in f(R)$, then $I^{*h} = I^{\bar{*}} \cap I^{*f} = I^{\bar{*}} \cap I^* = I^{\bar{*}}$. Hence $*_h$ and $\bar{*}$ coincides on $f(R)$, and it follows that $(*_h)_f = (\bar{*})_f$. □

Lemma 4.1.7. *Let $*$ be a semistar operation on R . TFAE.*

1. $(\bar{*})_f = \tilde{*}$.
2. $(\bar{*})_f$ is stable.
3. $(\bar{*})_f$ is finite stable.

4. Let $S = \{I \in \overline{F}(R) \mid I^{\overline{*}} = I^{(\overline{*})_f}\}$. Then S is closed under finite intersection.

5. $*_h$ is finite stable.

6. For any semistar operation $*'$ of finite type such that $\tilde{*} \leq *' \leq \overline{*}$, $*'$ is stable.

Proof. Note that $\overline{*}_f \leq \overline{*}$ by Lemma 2.1.10, and since $\tilde{*} = \overline{*}_f$ is of finite type by Theorem 2.1.6, $\tilde{*} = (\overline{*}_f)_f \leq (\overline{*})_f \leq \overline{*}$.

1 \Rightarrow 2: Obvious, since $\tilde{*}$ is stable.

2 \Rightarrow 1: It suffices to show that $(\overline{*})_f \leq \tilde{*}$ since the other inequality is always true, as indicated in the first line of this proof. Assume 2. Then since $(\overline{*})_f$ is stable $(\overline{*})_f = \overline{(\overline{*})_f} \leq \overline{*}_f = \tilde{*}$ by Lemma 2.1.8 and Lemma 2.1.10.

2 \Leftrightarrow 3: Follows from Lemma 4.1.5.

2 \Rightarrow 4: Assume 2 holds, and let $I, J \in S$. Then $(I \cap J)^{\overline{*}} = I^{\overline{*}} \cap J^{\overline{*}} = I^{(\overline{*})_f} \cap J^{(\overline{*})_f} = (I \cap J)^{(\overline{*})_f}$, so 4 follows.

4 \Rightarrow 3: Suppose that 3 is true. Then given $I, J \in f(R)$, $I \cap J \in S$ since $f(R) \subseteq S$. Therefore, $(I \cap J)^{(\overline{*})_f} = (I \cap J)^{\overline{*}} = I^{\overline{*}} \cap J^{\overline{*}} = I^{(\overline{*})_f} \cap J^{(\overline{*})_f}$ and $(\overline{*})_f$ is finite stable.

1 \Leftrightarrow 5: By Lemma 4.1.4, $*_h$ is finite stable if and only if $(*_h)_g$ is stable if and only if $(*_h)_f \leq \overline{*}_h$. But by Lemma 4.1.6, this happens if and only if 1 holds.

1 \Rightarrow 6: Let $*'$ of finite type such that $\tilde{*} \leq *' \leq \overline{*}$. If 1 is true, then $(\overline{*})_f \leq *' \leq \overline{*}$, and by Lemma 2.1.10.3 $*' = (\overline{*})_f$. Then again by 1, $* = \tilde{*}$ and $*$ is stable.

6 \Rightarrow 2: Obvious from the first line of this proof. □

Fontana and Huckaba raised a question concerning the characterizations of a localizing system \mathcal{F} on a domain R such that $*_{\mathcal{F}_f} = (*_{\mathcal{F}})_f$ ([21, p.181]). Now the following corollary partially answers this question, extending [57].

Corollary 4.1.8. *Let R be an integral domain and \mathcal{F} a localizing system on R . TFAE.*

1. $*_{\mathcal{F}_f} = (*_{\mathcal{F}})_f$.

2. $(*_\mathcal{F})_f$ is stable.
3. $(*_\mathcal{F})_f$ is finite stable.
4. Let $S = \{I \in \overline{F}(R) \mid I^{*\mathcal{F}} = I^{(*\mathcal{F})_f}\}$. Then S is closed under finite intersection.
5. For any semistar operation $*$ of finite type such that $*_{\mathcal{F}_f} \leq * \leq *_\mathcal{F}$, $*$ is stable.

Proof. Note that $\mathcal{F}^{*f} = (\mathcal{F}^*)_f$ by [21, Corollary 3.8]. Now let $* = *_\mathcal{F}$. Then by Lemma 2.1.10.1, $\mathcal{F}^* = \mathcal{F}$. Thus $(\overline{*})_f = (*_{\mathcal{F}^*})_f = (*_{\mathcal{F}})_f$ and $\tilde{*} = *_{\mathcal{F}^{*f}} = *_{(\mathcal{F}^*)_f} = *_{\mathcal{F}_f}$. Now the corollary follows from Lemma 4.1.7. \square

Recall that an integral domain R is said to be *coherent* if the intersection of any two finitely generated ideals of R is a finitely generated ideal.

Corollary 4.1.9. *Let R be a coherent domain. Then $(\overline{*})_f = \tilde{*}$ for each semistar operation $*$ on R . In particular, $*_{\mathcal{F}_f} = (*_{\mathcal{F}})_f$ for each localizing system \mathcal{F} of R .*

Proof. Choose a semistar operation $*$ on R . Given two $I, J \in f(R)$, $I \cap J \in f(R)$ and $(I \cap J)^{(\overline{*})_f} = (I \cap J)^{\overline{*}} = I^{\overline{*}} \cap J^{\overline{*}} = I^{(\overline{*})_f} \cap J^{(\overline{*})_f}$. Thus $(\overline{*})_f$ is finite stable and $(\overline{*})_f = \tilde{*}$ by Lemma 4.1.7. The second assertion follows similarly. \square

4.2 Prüfer domains and P*MDs

Recall that given a semistar operation $*$, we say R is a *Prüfer $*$ -multiplication domain*, or *P*MD* for short, if every nonzero element of $f(R)$ is $*_f$ -invertible. It is well known that R is a P*MD if and only if R_P is a valuation domain (an integral domain R is said to be a *valuation domain* if the set of ideals of R is totally ordered under inclusion) for each $P \in *_f \text{Max}(R)$ ([23, Theorem 3.1]). The following yields a characterization of P*MD.

Lemma 4.2.1. *Let R be a domain and $*$ a semistar operation on R . TFAE.*

1. R is a P^*MD .
2. For a semistar operation $*'$ on R such that $*_f \leq *'$, R is a P^*MD .
3. For a semistar operation $*'$ of finite type on R such that $*_f \leq *'$, $*'$ is stable.
4. For a semistar operation $*'$ on R such that $*_f \leq *'$, $*'$ is finite stable.
5. For a semistar operation $*'$ on R such that $*_f \leq *'$, $(*)'_g$ is stable.
6. $*_f$ is stable and I is a $*_f$ -cancellation ideal for all $I \in f(R)$.

Proof. 1 \Rightarrow 2: Assume that 1 holds, and let $*'$ be a semistar operation on R such that $*_f \leq *'$. Now for each $I \in f(R)$, I is $*_f$ -invertible, and by Lemma 2.1.8 and Lemma 2.2.2 I is $*'$ -invertible. Thus 2 follows.

2 \Rightarrow 3: Suppose that 2 holds, $*'$ a semistar operation of finite type on R such that $*_f \leq *'$. Pick a nonzero finitely generated ideal I of R . Then $I^{*'} \subseteq IR_P$ for all $P \in {}^*Max(R)$. Otherwise, there exists $x \in I^{*'} \setminus IR_P$. Now $IR_P \subsetneq xR_P$ since R is a P^*MD and R_P is a valuation domain. In particular, $x^{-1} \in IPR_P$. Now $x^{-1} = ips^{-1}$ for some $i \in I$, $p \in P$ and $s \in R \setminus P$ since R_P is a valuation domain. Therefore $s = pix \in pI^{*'} \subset P^{*'}$. But then since $P \in {}^*Max(R)$, by Lemma 2.1.14, $P^{*'} = (P^{*'})^{*'} = (P^{*'} + sR)^{*'} = (P + sR)^{*'} = R^{*'}$, which is a contradiction. Hence $I^{*'} \subseteq \cap \{IR_P \mid P \in {}^*Max(R)\} = I^{\tilde{*}'}$. Therefore $*' = \tilde{*}'$ on the set of finitely generated ideals, and it follows that $*' = \tilde{*}'$ on $f(R)$. Since both $*'$ and $\tilde{*}'$ are of finite type, we have $*' = \tilde{*}'$. Since $\tilde{*}'$ is stable, $*'$ must be stable.

3 \Rightarrow 4: Let $I, J \in f(R)$ and $*'$ a semistar operation on R such that $* \leq *'$. If 3 is true, then $(*)'_f$ is stable, so $(I \cap J)^{*'}$ \subseteq $I^{*'}$ \cap $J^{*'}$ $= I^{(*')_f}$ \cap $J^{(*')_f}$ $= (I \cap J)^{(*')_f}$ \subseteq $(I \cap J)^{*'}$. Therefore $*'$ is finite stable.

4 \Rightarrow 5: Immediate consequence of Lemma 4.1.4(b).

5 \Rightarrow 6: Suppose that 5 is true. Then $(*)'_g$ is stable. Hence by Lemma 4.1.4(b), we have

$(*_f)_f = *_f \leq \overline{*_f} = \tilde{*} \leq *_f$ and $*_f \leq \bar{*}$. Thus $\tilde{*} = *_f \leq \bar{*}$, so $*_f$ is stable.

Now let $*' = (*_f)_{f(R)}$. Then by Lemma 3.0.3, $*_f \leq *'$ and $*'$ is of finite type. Hence $(*')_g$ is stable by assumption, and $*' = (*')_f \leq \overline{*'} \leq *'$. Thus $*'$ is stable. Therefore by Lemma 3.0.4(b) $*' = *_f$, and by Lemma 3.0.4(a) every element of $f(R)$ is a $*_f$ -cancellation ideal.

6 \Rightarrow 1: Assume 6. Then $*_f$ is stable, so by Lemma 2.2.7 I is $*_f$ -invertible for all $I \in f(R)$. Hence R is a P*MD. □

Recall that a *Prüfer domain* is a domain such that every nonzero finitely generated ideal is invertible. It follows that a Prüfer domain is exactly a PdMD, where d is the identity operation (see Example 2.1.5). Prüfer domains could be characterized in a surprisingly many ways; for example, R is a Prüfer domain if and only if R_P is a valuation domain for each prime ideal P of R ([41, Theorem 64]). At least twenty-six different characterizations of a Prüfer domain were known in 1970s ([29, Theorems 22.1, 24.3, 24.7, 25.2]), and nowadays there are maybe more than half a hundred of them available here and there in the literature. The next lemma gives yet another description of Prüfer domains in terms of semistar operations, which is a slight extension of [70, Proposition 2.2].

Lemma 4.2.2. *Let R be a domain. Then the following are equivalent.*

1. R is a Prüfer domain.
2. Every semistar operation of finite type on R is stable.
3. Every semistar operation is finite stable.
4. $*_g$ is stable for each semistar operation $*$ on R .
5. I is a cancellation ideal for every $I \in f(R)$.
6. $*_f = \tilde{*}$ for each semistar operation $*$ on R .

7. The map ϕ from the set of semistar operations of finite type of R to the set of localizing systems of finite type of R , defined by $\phi(*) = \mathcal{F}^*$ for each $* \in SStar(R)$, is an injective map.

Proof. $1 \Leftrightarrow 2 \Leftrightarrow 3 \Leftrightarrow 4 \Leftrightarrow 5$: This is just a special case of Lemma 4.2.1 when $* = d$.

$3 \Rightarrow 6$: Suppose that 3 holds. Let $*$ be a semistar operation. Then $*_f$ is finite stable by assumption, and $*_f = (\overline{*)_f} \leq \tilde{*} \leq *_f$ by Lemmas 2.1.10 and Lemma 4.1.4.3.(b). Hence 6 follows.

$6 \Rightarrow 3$: Since $\tilde{*} \leq (\overline{*)_f \leq *_f$ for each semistar operation $*$ on R , this is immediate from Lemma 4.1.4.3.(b).

$2 \Rightarrow 7$: Suppose that 2 holds. Then given two semistar operations $*_1, *_2$ of finite type such that $\mathcal{F}^{*_1} = \mathcal{F}^{*_2}$, we have $*_1 = \overline{*_1} = *_{\mathcal{F}^{*_1}} = *_{\mathcal{F}^{*_2}} = \overline{*_2} = *_2$ by Lemma 2.1.10.2. Thus ϕ is injective.

$7 \Rightarrow 2$: Note that given a semistar operation $*$ of finite type, $\mathcal{F}^* = \mathcal{F}^{\overline{*}}$ by Lemma 2.1.7. Hence if ϕ is an injective map, then for each semistar operation $*$ of finite type on R , we have $* = \overline{*}$ and $*$ is stable by Lemma 2.1.10.2. \square

Lemma 4.2.3. *Let R be a domain. Then the following are equivalent.*

1. $*_g$ is of finite type for each semistar operation $*$ on R .
2. $\overline{*} = (\overline{*)_f$ for each semistar operation $*$ on R .
3. $\overline{*} = \tilde{*}$ for each semistar operation $*$ on R .
4. Every stable semistar operation on R is of finite type.
5. Every localizing system on R is of finite type.

Proof. $1 \Rightarrow 2$: Suppose that 1 is true. Given a semistar operation $*$, $(\overline{*)_g$ is of finite type, so by Lemma 4.1.4 (c), $\overline{*} = \overline{\overline{*)_g} \leq (\overline{*)_f \leq \overline{*}$. Hence $\overline{*} = (\overline{*)_f$.

$2 \Rightarrow 3$: Suppose 2 holds. Then given a semistar operation $*$ on R , $\overline{*} = \overline{\overline{*)_f} \leq \overline{*_f} =$

$\tilde{*} \leq \bar{*}$ by Lemmas 2.1.8 and 2.1.10. Hence 3 follows.

3 \Rightarrow 4: Note that given a semistar operation $*$ on R , $\tilde{*} = *_{\mathcal{F}^*f}$ is of finite type by Theorem 2.1.6. Now the conclusion follows from Lemma 2.1.10.2.

4 \Rightarrow 5: Let \mathcal{F} be a localizing system on R . Then $*_{\mathcal{F}}$ is a stable semistar operation ([21, Proposition 2.4]). Therefore, if 3 is true, then $*_{\mathcal{F}}$ must be of finite type. Moreover, since $\mathcal{F} = \mathcal{F}^{*_{\mathcal{F}}}$ by Lemma 2.1.10.1, \mathcal{F} is a localizing system of finite type by Theorem 2.1.6.

4 \Rightarrow 1: Note that given a semistar operation $*$, \mathcal{F}^* is a localizing system of R ([21, Proposition 2.8]). Now suppose that 4 is true. Then \mathcal{F}^* is a localizing system of finite type, and $\bar{*} = *_{\mathcal{F}^*}$ is of finite type by Theorem 2.1.6. Hence $\bar{*} \leq *_{\mathcal{F}}$ by Lemma 2.1.10 and $*_{\mathcal{G}} = *_{\mathcal{F}}\bar{*} = *_{\mathcal{F}}$. Hence $*_{\mathcal{G}}$ is of finite type. \square

Recall that a Prüfer domain R is said to be a *generalized Dedekind domain* if given two localizing systems \mathcal{F}_1 and \mathcal{F}_2 of R , $R^{*\mathcal{F}_1} = R^{*\mathcal{F}_2}$ if and only if $\mathcal{F}_1 = \mathcal{F}_2$ ([22, Chapter 5.2]). We now present a new characterizations of generalized Dedekind domains in terms of $*_{\mathcal{G}}$.

Theorem 4.2.4. *Let R be a domain. Then the following are equivalent.*

1. R is a generalized Dedekind domain.
2. R is a Prüfer domain and every localizing system on R is of finite type.
3. $*_{\mathcal{G}}$ is stable and of finite type for each semistar operation $*$ on R .
4. $\bar{*} = *_{\mathcal{F}}$ for each semistar operation $*$ on R .
5. R is a Prüfer domain and every stable semistar operation on R is of finite type.
6. A semistar operation is stable if and only if it is of finite type.

Proof. 1 \Leftrightarrow 2 follows from [22, Theorem 5.2.1]. 3 \Leftrightarrow 4 follows from Lemma 4.1.4. Other implications follow from Lemma 4.2.2 and Lemma 4.2.3. \square

One may wonder when the composition of two arbitrary semistar operations on an integral domain yields a semistar operation. Let us study the properties of such integral domains.

Definition 4.2.5. An integral domain R is *conductive* if each overring of R other than K is a fractional ideal of R . Given an overring T of R , if $I^{v(R)} = R$ for $I \in f(R)$ implies $(IT)^{v(T)} = T$, then we say that T is a *t-linked overring* of R . R is said to be *t-linkative* if every overring of R is t-linked, and *super t-linkative* if every overring of R is t-linkative.

For a more detailed treatment of t-linkative domains one may refer to [18] and [19].

Theorem 4.2.6. [17, Theorem 3.2], [59, Proposition 7] 1. For a domain R , TFAE.

- (a) R is a conductive domain.
 - (b) $R : V \neq 0$ for some valuation overring V of R .
 - (c) $R : T \neq 0$ for each $T \in \overline{F}(R) \setminus \{K\}$.
 - (d) Each overring of R is of the form $I : I$.
2. Every valuation domain is conductive.

We now introduce the notion of a c^* -domain.

Definition 4.2.7. If R is an integral domain such that the composition of any two semistar operation on R is also a semistar operation on R , then we say R is *c^* -domain*.

The following are some basic properties of c^* -domains.

- Lemma 4.2.8.** 1. An integral domain R is a c^* -domain if and only if $*_1*_2 = *_2*_1$ for any two semistar operation $*_1$ and $*_2$ of R .
2. Each c^* -domain is conductive.
3. Given a semistar operation $*$ on a c^* -domain R , an overring T of R and $J \in \overline{F}(R)$,

we have $(JT)^* = J^*T$. In particular, every overring of R other than K is a divisorial fractional ideal of R .

4. Each overring of a c^* -domain is a c^* -domain.
5. Each c^* -domain is super t -linkative.
6. $v(I)^* \leq v(I^*)$ for each nonzero $I \in \overline{F}(R)$ and semistar operation $*$ on a c^* -domain R .
7. If $(SStar(R), \leq)$ is a totally ordered set, then R is a c^* -domain.

Proof. 1. Follows from Lemma 4.1.1.

2. ([68, Example 2.1(1)]). Let R be a c^* -domain. Suppose that R is not conducive. Then there exists an overring $T \neq K$ of R such that $R : T = 0$. Now set $*_1 = v(R)$ and $*_2 = *_T$. Then $R^{*_1*_2} = T$ and $R^{*_2*_1} = K$, so $R^{*_2*_1} \not\subseteq R^{*_1*_2}$. Hence $*_1*_2$ is not a semistar operation by Lemma 4.1.1, and we have a contradiction.

3. By 1, $(JT)^* = J^{*T} = (J^*)^{*T} = J^*T$. Now since $T^{v(R)} = (RT)^{v(R)} = R^{v(R)}T = T$ for each overring T of R , the second assertion follows from 2.

4. If $*_1$ and $*_2$ are semistar operations on T , then $*_1^t$ and $*_2^t$ are semistar operation on R . Thus given $I \in \overline{F}(T) \subseteq \overline{F}(R)$,

$$I^{*_2*_1} = ((IT)^{*_2}T)^{*_1} = I^{*_2^t*_1^t} = I^{*_1^t*_2^t} = I^{*_1*_2}.$$

So by Lemma 4.1.1 $*_1*_2$ is a semistar operation on T .

5. Let T be an overring of R . From 3 and Lemma 2.1.9 it follows that $v(R) \leq v(T)$. Therefore, if $I \in f(R)$ such that $I^{v(R)} = R$, then $I^{v(T)} = (I^{v(R)})^{v(T)} = R^{v(T)} = T$ and $(IT)^{v(T)} = I^{v(T)}T = T$. Hence R is t -linkative, and by 4 R is super t -linkative.

6. Note that $(I^*)^{v(I)} = (I^{v(I)})^* = I^*$ and $v(I) \leq v(I^*)$ by Lemma 2.1.9. Moreover, $* \leq v(I^*)$ since $(I^*)^* = I^*$. Therefore $*v(I) \leq v(I^*)$.

7. Follows from Lemma 4.5.1. □

From Lemma 4.1.3 we can immediately see that if each semistar operation on an integral domain R is of finite type and stable, then R is a c^* -domain. So the resulting question is to ask the possible characterizations of such domains. The next lemma shows that any such domain must be a totally divisorial valuation domain.

Definition 4.2.9. A nonzero ideal I of R is a *divisorial ideal* of R if $I^{v(R)} = I$. R is said to be a *divisorial domain* if every nonzero ideal of R is divisorial. If each overring of R is a divisorial domain, then we say that R is a *totally divisorial domain*. A Prüfer domain R is said to be *strongly discrete* if $P^2 \neq P$ for each nonzero prime ideal P of R .

Lemma 4.2.10. *Let R be a domain. Then the following are equivalent.*

1. *Each semistar operation on R is stable and of finite type.*
2. *R is a totally divisorial valuation domain.*
3. *R is a strongly discrete valuation domain.*
4. *R is integrally closed, totally divisorial and conducive.*
5. *R is integrally closed and each semistar operation on R is an extension to some overring of R .*
6. *R is a Prüfer domain and each semistar operation on R is of finite type.*
7. *$* = \tilde{*}$ for each semistar operation $*$ on R .*

Proof. $1 \Rightarrow 2$: Suppose that 1 is true. Then R is a Prüfer domain by Lemma 4.2.2. Now $v = t = *_R = d$ by assumption and the fact that each finite semistar operation on a Prüfer domain is an extension to some overring ([69, Lemma 2.40]), so R is a divisorial domain and must be h-local by [34, Proposition 2.4]. On the other hand, the composition of any two semistar operations on R is a semistar operation by 4.1.2, so R is conducive by Theorem 4.2.8.2. Therefore R must be a valuation domain ([69, Lemma 2.42]). Since each semistar operation on R is an extension to an overring of R ,

R is totally divisorial by Theorem 4.3.9.

2 \Leftrightarrow 3: Follows from [69, Theorem 2.43].

2 \Rightarrow 4: Follows from the fact that each valuation domain is conducive (Theorem 4.2.6) and integrally closed ([50, Theorem 10.3]).

4 \Leftrightarrow 5: Follows from Theorem 4.3.9.

5 \Rightarrow 6: If 5 holds, then each semistar operation on R is an extension to some overring on R , so in particular every semistar operation on R is of finite type. Moreover, since $t = *_R t = d$ and R is integrally closed, R is a Prüfer domain by [76, Theorem 8].

6 \Rightarrow 7: Immediate corollary of Lemma 4.2.2.

7 \Rightarrow 1: Immediate corollary Lemma 2.1.10.5. □

In the next corollary, we summarize the characterizations of a certain classes of Prüfer domains in the language of semistar operations.

Corollary 4.2.11. *Let R be an integral domain. Then*

1. R is a Prüfer domain $\Leftrightarrow *_f = \tilde{*}$ for each $* \in SStar(R)$.
2. R is a generalized Dedekind domain $\Leftrightarrow *_f = \bar{*}$ for each $* \in SStar(R)$.
3. R is a strongly discrete valuation domain $\Leftrightarrow * = \tilde{*}$ for each $* \in SStar(R)$.

Proof. 1. By Lemma 4.2.2.

2. By Theorem 4.2.4.

3. By Lemma 4.2.10. □

4.3 Semistar operations of type $v(I)$

Recall that given an ideal I of R , the map $v(I) : \overline{F}(R) \rightarrow \overline{F}(R)$ defined by $L^{v(I)} = I : (I : L)$ for each $L \in \overline{F}(R)$ is a semistar operation ([69, Proposition 1.17]).

We may ask a natural question; which integral domain R has the property that given a semistar operation $*$ on R , there exists an ideal I of R so $*$ = $v(I)$? Valuation domains are one such, as the following result due to Picozza ([69, Proposition 2.35]) shows.

Theorem 4.3.1. *Let R be a valuation domain. Then the following hold;*

1. *Given $P \in \text{Spec}(R)$, $v(P) = *_{R_P}$.*
2. *Given a semistar operation $*$ on R there exists an ideal I of R such that $*$ = $v(I)$.*
3. *Given an ideal I of R and $P \in \text{Spec}(R)$, $v(I) = *_{R_P}$ if and only if $I = xP$ for some nonzero $x \in K$.*

One can immediately see that condition 3 implies condition 1 in Theorem 4.3.1. In fact, we are going to prove that they are equivalent to the statement that R is a valuation domain. First, recall that an ideal I of R is said to be an *m-canonical ideal* of R if $J^{v(I)} = J$ for each nonzero ideal J of R . Now consider the following lemma.

Lemma 4.3.2. *([11, Proposition 4.1]) Let R be a quasilocal domain with maximal ideal M . Then R is a valuation domain if and only if M is an m-canonical ideal of R .*

Theorem 4.3.3. *Let R be an integral domain. Then the following are equivalent.*

1. *R is a valuation domain.*
2. *Given an ideal I of R and $P \in \text{Spec}(R)$, $v(I) = *_{R_P}$ if and only if $I = xP$ for some nonzero $x \in K$.*
3. *$v(P) = *_{R_P}$ for each prime ideal P of R .*
4. *$v(M) = *_{R_M}$ for each maximal ideal M of R .*

Proof. 1 \Rightarrow 2: Follows from Theorem 4.3.1.

2 \Rightarrow 3 \Rightarrow 4: Trivial.

4 \Rightarrow 1: Assume that 3 is true. Choose a maximal ideal M of R . Then we have

$v(M) = *_{R_M}$ and $M = M^{v(M)} = M^{*_{R_M}} = MR_M$. Hence for any $r \in R - M$, $r^{-1}M \subseteq MR_M = M$ and $M \subseteq rM \subsetneq rR$, so r is a unit. Therefore R is quasilocal with maximal ideal M , and by assumption $J^{v(M)} = J^{*_{R_M}} = JR_M = J$ for each nonzero ideal J of R . Thus M is an m -canonical ideal of R and R is a valuation domain by Lemma 4.3.2. \square

By Theorems 4.3.1 and 4.3.3, condition 1 and condition 3 of Theorem 4.3.1 are equivalent to R being a valuation domain. Thus the following question arises; is condition 2 of Theorem 4.3.1 equivalent to the other two? i.e., if each semistar operation on R is of the form $v(I)$ for some ideal I of R , then is R a valuation domain? The answer is negative, as we are going to show in this section.

Definition 4.3.4. An integral domain R is said to be of *finite character* if for each nonzero ideal I of R there exists only finitely many maximal ideals of R that contains I . A *pm-domain* is an integral domain R such that each nonzero prime ideal is contained in a unique maximal ideal of R . An *h-local domain* is a pm-domain of finite character.

Lemma 4.3.5. 1. A conducive pm-domain is quasilocal.

2. A conducive domain with an m -canonical ideal is quasilocal.

Proof. 1. Let R be a conducive domain. Then there exists a nonzero prime ideal P of R such that given any prime ideal Q of R , either $P \subseteq Q$ or $Q \subseteq P$, and $\{N \in \text{Spec}(R) \mid N \subseteq P\}$ is totally ordered by inclusion ([17, Corollary 3.3]). Since R is a pm-domain, P must be contained in a maximal ideal M . Hence R must be a quasilocal domain.

2. An integral domain that has an m -canonical ideal is h -local ([34, Proposition 2.4]).

Thus the conclusion follows from 1. \square

For the sake of brevity, we will say that R has *property ** (respectively, *weak property **) if R is an integral domain that is not a field such that for each semistar

operation $*$ (respectively, for each semistar operation on R that is an extension to an overring of R) there exists an ideal I of R such that $* = v(I)$.

Lemma 4.3.6. *Let R be an integral domain that has weak property $*$. Then*

1. *For each overring T of R , T has weak property $*$. In particular, every overring of R has an m -canonical ideal.*
2. *R is a conducive quasilocal domain.*
3. *For each overring T of R , $\text{Spec}(T)$ is totally ordered under inclusion. In particular, T is quasilocal.*
4. *Let $*$ be a semistar operation on R that is stable and of finite type. Then $*$ is an extension to a localization of R .*
5. *An overring T of R is flat R -module if and only if $T = R_P$ for some prime ideal P of R .*
6. *If $R^* = \widetilde{R^*}$ for each semistar operation $*$ on R that is an extension to an overring of R , then R is a valuation domain.*

Proof. 1. Assume that R has weak property $*$ and let T be an overring of R and $*$ a semistar operation on T that is an extension to an overring of T . Then consider $*^\iota$ (see Example 2.1.5.8). Since $L^{*\iota} = (LT)^* = LTT^* = LT^* = LR^{*\iota}$ for each $L \in \overline{F}(R)$, $*^\iota$ is a semistar operation on R that is an extension to R^* . Thus $*^\iota = v(I)$ for some ideal I of R by assumption. Now $T^* = R^{*\iota} = R^{v(I)} = I : I$, so $I \subseteq IT \subseteq IT^* = I$, and I is an ideal of T . Hence for each $N \in \overline{F}(T)$, $N^* = (NT)^* = N^{*\iota} = N^{v(I)}$, and $* = v(I)$. Thus T has weak property $*$.

2. Suppose that R has weak property $*$. Given an overring $T \neq K$ of R , $*_T = v(I)$ for some nonzero ideal I of R . Then $T = R^{*T} = R^{v(I)} = I : I$ and $IT = I(I : I) = I$, so T is a fractional ideal of R . Hence R is conducive. On the other hand, since $*_R = v(J)$

for some ideal J of R by assumption, J is an m -canonical ideal of R . Therefore R is quasilocal by Lemma 4.3.5.2.

3. Combining 1 and 2, we can conclude that if R has weak property $*$, then each overring T of R is a quasilocal domain. It follows that $\text{Spec}(R)$ is totally ordered under inclusion, and so is $\text{Spec}(T)$ for each overring T of R by 1.

4. Let $*$ be a semistar operation of finite type and stable. Then the set of maximal elements of $\{I \in \mathcal{S}(R) \mid I^* \cap R = I \subseteq R, I^* \subsetneq R^*\}$ is nonempty and must be a singleton set $\{P\}$ for some $P \in \text{Spec}(R)$ by 3, so $I^* = IR_P$ for each $I \in \overline{F}(R)$ by Lemma 2.1.14.

5. Follows from [43, Proposition 4.14].

6. Suppose that R has weak property $*$ and $R^* = \widetilde{R^*}$ for each semistar operation $*$ on R . Then given an overring T of R , $T = R^{*T} = \widetilde{R^{*T}}$ is a localization of R by 4 and Lemma 2.1.10.5, so R must be a Prüfer domain ([29, Page 334]). Since R is a quasilocal Prüfer domain, it is a valuation domain. \square

Remark 4.3.7. *Note that similar statements holds for domains that possess property $*$. For example, the proof of Lemma 4.3.6 can be modified to show that if a domain R has property $*$, then each overring of R has property $*$.*

Lemma 4.3.6 yields a characterization theorem of domains with weak property $*$.

Lemma 4.3.8. *Let R be an integral domain. Then the following are equivalent.*

1. R has weak property $*$.
2. R is a conducive domain and each overring of R has an m -canonical ideal.
3. R is a conducive domain that has an m -canonical ideal.

Proof. 1 \Rightarrow 2: Follows from Lemma 4.3.6.

2 \Rightarrow 3: Trivial.

3 \Rightarrow 1: Assume that 3 is true. It follows from [34, Proposition 5.1] that each overring T of R has an m -canonical ideal I_T . Hence $J^{*T} = JT = (JT)^{v(I_T)} = (J^{*T})^{v(I_T)} = J^{v(I_T)}$ for all $J \in \overline{F}(R)$. Moreover, there exists $d \in R - \{0\}$ such that dI_T is an ideal of R . Then $v(I_T) = v(dI_T)$, so $*_T = v(dI_T)$ and R has weak property $*$. \square

Recall that an ideal I of R is said to be *stable* if I is an invertible ideal of the ring $I : I$. If every nonzero ideal of R is stable, then we say that R is a *stable domain*.

Clearly each integral domain that has property $*$ also has weak property $*$, but the converse is false in general (see Remark 4.4.5). However, it turns out that these two properties are equivalent on stable domains. The following theorem extends [69, Proposition 2.51].

Theorem 4.3.9. *Let R be an integral domain. TFAE.*

1. R is a stable domain that has property $*$.
2. R is a stable domain that has weak property $*$.
3. R is conducive and $v(I) = *_I:I$ for each nonzero ideal I of R .
4. R is totally divisorial and conducive.
5. Each semistar operation of R is an extension to some overring of R .
6. Given two semistar operations $*_1$ and $*_2$ of R , $*_1 = *_2$ if and only if $R^{*1} = R^{*2}$.

We need the following preparatory lemmas for the proof of this theorem.

Lemma 4.3.10. *([68, Theorem 2.54]) For an integral domain R , TFAE.*

1. R is a stable domain.
2. $v(I) = v(I : I)$ for each nonzero ideal I of R .
3. If I and J are nonzero ideals of R such that $I : I = J : J$, then $v(I) = v(J)$.
4. I is divisorial in $I : I$ for each nonzero ideal I of R .

Lemma 4.3.11. ([68, Theorem 2.57]) For an integral domain R , TFAE.

1. R is totally divisorial.
2. Each nonzero ideal I of R is an m -canonical ideal of $I : I$.
3. $I : I$ is a divisorial domain for each nonzero ideal I of R .

Proof of Theorem 4.3.9.

1 \Rightarrow 2: Trivial.

2 \Rightarrow 3: Suppose that R is a stable domain that has weak property $*$. Then R is conducive by Lemma 4.3.6. Let I be a nonzero ideal of R , and $*_{I:I} = v(J)$ for some ideal J of R . Note that since $I : I = R^{*_{I:I}} = R^{v(J)} = J : J$, $v(I) = v(J)$ and $v(I) = *_{I:I}$.

3 \Rightarrow 4: If R a conducive domain, then a nonzero ideal I of R is an m -canonical ideal of $I : I$ if and only if $v(I) = *_{I:I}$ ([69, Lemma 2.34]). Hence, by Lemma 4.3.11, 3 implies 4.

4 \Leftrightarrow 5: [69, Proposition 2.51].

5 \Rightarrow 6: If 5 holds, then given two semistar operations $*_1, *_2$ of R , $*_i = *_{R^*_i}$ for $i = 1, 2$. Therefore 6 follows.

6 \Rightarrow 1: Suppose that 6 is true. Then, given two nonzero ideals I, J of R such that $I : I = J : J$, $R^{v(I)} = I : I = J : J = R^{v(J)}$ and $v(I) = v(J)$. Hence by Lemma 4.3.10 R is stable. On the other hand, since $R^{v(R)} = R^d = R$, we have $v(R) = d$ by assumption. Now if $T \neq K$ is an overring of R , then $R : T \neq 0$. For otherwise $T = T^{v(R)} = R : (R : T) = R : 0 = K$, which is a contradiction. Therefore R is conducive. Now it follows that given a semistar operation $*$, $R^* = I : I$ for some ideal I of R . Then $R^* = R^{v(I)}$, and $* = v(I)$ by assumption and R has property $*$. \square

The stability of an ideal I is related to $v(I)$ -cancellativity, as the following lemma shows.

Lemma 4.3.12. 1. *An integral domain R is stable if and only if I is a $v(I)$ -cancellation ideal for each nonzero ideal I of R .*

2. *Suppose that each nonzero ideal I of R is a $v(I)$ -invertible ideal of R . Then R is a stable domain.*

Proof. 1. Given $L \in \overline{F}(R)$, $L^{v(I:I)} = (I : I) : ((I : I) : L) = I : I(I : IL) = (I : (I : IL)) : I = (IL)^{v(I)} : I$. Hence by Lemma 2.2.3 I is a $v(I)$ -cancellation ideal if and only if $L^{v(I:I)} = L^{v(I)}$ for each $L \in \overline{F}(R)$. Therefore by Lemma 4.3.10 we are done.

2. Follows immediately from Lemma 2.2.2. □

The converse of Lemma 4.3.12.2 is false, as the following theorem and remark show.

Theorem 4.3.13. *For an integral domain R that is not a field, the following are equivalent.*

1. *R is a Noetherian valuation domain.*
2. *R satisfies the following properties;*
 - (a) *Given a nonzero ideal I of R , I is $v(I)$ -invertible ideal of R .*
 - (b) *R has weak property $*$.*

Proof. 1 \Rightarrow 2: Let R be a Noetherian valuation domain. Then R is a PID ([50, Theorem 11.2]), so for a nonzero ideal I of R , I is invertible. Since $d \leq v(I)$, I is $v(I)$ -invertible by Lemma 2.2.2.2, so (a) follows. On the other hand, Theorem 4.3.1 yields (b).

2 \Rightarrow 1: Suppose that 2 is true. Then by Lemma 4.3.6, R is a quasilocal domain with the maximal ideal M , and given an overring $T \neq K$ there exists a nonzero ideal I such that $T = I : I$ and $v(I) = *_{I:I}$. Now for any $X \in \overline{F}(R)$, we have $(IX)^{v(I)} = (IX)^{*_{I:I}} = IX(I : I) = IX$. Then $R \subseteq I : I = R^{v(I)} = (I(R : I))^{v(I)} = I(R : I) \subseteq R$ since I is $v(I)$ -invertible in R . Hence $T = I : I = R$ and R is a one-dimensional valuation

domain since R has no overring other than R and K ([50, Exercise 10.5]). It remains to show that R is Noetherian. Now, M is an m -canonical ideal by Lemma 4.3.2 and M is $v(M)$ -invertible by assumption, so it follows that M is invertible. Since invertible ideals are finitely generated ([41, Theorem 58]), M must be finitely generated. On the other hand, $\text{Spec}(R) = \{0, M\}$ since R is a one-dimensional quasilocal domain. Hence every prime ideal of R is finitely generated and R is Noetherian by Cohen's theorem. \square

Remark 4.3.14. *From Theorem 4.3.3 it follows that the first and the third statements of Theorem 4.3.1 are equivalent to the statement that R is a valuation domain. Moreover, this result is sharp in the sense that even if R is an integral domain that satisfies the second statement of Theorem 4.3.1, R may not be a valuation domain. Indeed, let L be a field, X an indeterminate, $R = L[[X^2, X^3]] = \{a_0 + \sum_{n \geq 2} a_n X^n \mid a_n \in L, n \geq 0\}$ and $M = (X^2, X^3)R$. It is well-known that R has only three overrings and three semistar operations (cf. [58, Example 72]), and we suggest a proof of these facts using multiplicative ideal theoretic method. Consider the following theorem proved by Vassilev.*

Theorem 4.3.15. *[74, Proposition 4.1] Let I be a nonzero proper ideal of R . Then either $I = (X^n + aX^{n+1})R$ for some $a \in L, n \geq 2$ or $I = X^n M = (X^{n+2}, X^{n+3})R$ for some $n \geq 0$.*

Therefore given an ideal I of R , we have

$$I : I = \begin{cases} R, & \text{if } I \text{ is nonzero principal} \\ M : M, & \text{if } I = X^n M \text{ for some } n \geq 0 \\ K, & \text{if } I = 0. \end{cases}$$

Now consider the overring $L[[X]]$ of R . Since $L[[X]]$ is a quasilocal PID, it is a (Noetherian) valuation domain. Moreover, since $ML[[X]] \subseteq R$, we have $0 \neq M \subseteq R :$

$L[[X]]$ and R is conducive by Theorem 4.2.6. Therefore again by Theorem 4.2.6 each overring of R is of the form $I : I$ for some ideal I of R . Hence $R, M : M$ and K are the only overrings of R . Since $L[[X]]$ is an overring of R different from R and K , we must have $L[[X]] = M : M$. We want to show that R is totally divisorial. Even though it is an immediate consequence of Theorem 4.3.15 and [8, Proposition 4.8], we present another proof based on multiplicative ideal theory.

Note that a nonzero principal ideal is divisorial, and each nonprincipal ideal of R is $X^n M$ for some $n \geq 0$ by the preceding theorem. Therefore to show that R is divisorial it suffices to show that M is divisorial. Note that R is a one-dimensional quasilocal domain since it is conducive and Noetherian ([17, Corollary 2.7]), and M is the only nonzero prime ideal of R . Hence $v(R)_f \text{Max}(R) = \{M\}$ ([21, Lemma 4.20]) and $M^{v(R)} = M^{v(R)_f} = M$. (alternately, one may use [45, Theorem 3.8], or [41, Exercise 4-5.1] and [41, Theorem 222]). Finally, since every PID is divisorial, $L[[X]]$ and K are divisorial domains.

Therefore R is totally divisorial and conducive. Hence, by Theorem 4.3.9, R has only three semistar operations $\{*_R(= d), *_L[[X]], *_K(= e)\}$ and R satisfies the second statement of Theorem 4.3.1. However, since M is a finitely generated nonprincipal ideal of R , R is not a valuation domain.

Hence R is a Noetherian totally divisorial conducive domain, and must be stable by Theorem 4.3.9. On the other hand, since R is not a valuation domain there exists a nonzero ideal I of R that is not $v(I)$ -invertible by Theorem 4.3.13 (in particular, M is not $v(M)$ -invertible). Thus the converse of Lemma 4.3.12.2 is false.

4.4 Semistar operations on the ring $R = L + X^3L[[X]]$

Let L be a field, X an indeterminate and $R = L + X^3L[[X]]$. Throughout the remainder of this section, R will denote this particular integral domain unless stated otherwise.

The fact that R has three star operations and six semistar operations is not quite new ([46, Proposition 6.1], [34, Theorem 3.8]), but with the aid of the following theorem by Vassilev, something more could be said. R will act as examples and counterexamples often throughout the remainder of this thesis.

Theorem 4.4.1. ([73, Proposition 3.6]) *The nonzero nonunit ideals of R can be expressed in the forms $P_{n,a,b} = (X^n + aX^{n+1} + bX^{n+2})$, $I_{n,a} = (X^n + aX^{n+1}, X^{n+2})$, $J_{n,a,b} = (X^n + aX^{n+2}, X^{n+1} + bX^{n+2})$ or $M_n = (X^n, X^{n+1}, X^{n+2})$ for some $n \geq 3$ and $a, b, \in L$.*

Theorem 4.4.2. [37, Theorems 3.8 and 4.2] *Let R be a Noetherian quasilocal domain with nonprincipal maximal ideal M and $k = R/M$ the residue field of R . Suppose that $R : M$ is a quasilocal domain, M is not the maximal ideal of $R : M$ and $\dim_k((R : M)/M) = 3$. Then*

1. R has exactly three star operations.
2. Each nonprincipal ideal I of R such that $I : I = R$ is an m -canonical ideal.
3. There exists only one proper overring between R and $R : M$.

The following theorem will be used frequently.

Theorem 4.4.3. [53, Theorem 2.2] *Let R be an integral domain with a proper overring T . Then $|\text{Star}(R)| + |\text{SStar}(T)| \leq |\text{SStar}(R)|$ and the equality holds if and only if R is a quasilocal conducive domain and each proper overring of R contains T .*

Now we are ready to prove that R has exactly six semistar operations.

Theorem 4.4.4. 1. R has exactly three (semi)star operations.

2. Given $n \geq 3$ and $a, b \in L$, $M_n : M_n = L[[X]]$, $I_{n,a} : I_{n,a} = L + X^2L[[X]]$, $P_{n,a,b} :$

$P_{n,a,b} = J_{n,a,b} : J_{n,a,b} = R$.

3. R has exactly four overrings $R \subsetneq L + X^2L[[X]] \subsetneq L[[X]] \subsetneq K$.

4. R has exactly six semistar operations $d, *', v(R), *_{L+X^2L[[X]]}, *_{L[[X]]}$, and e , where

$*' = *_{L+X^2L[[X]]} \wedge v(R)$.

5. $\{J_{n,a,b} \mid a, b \in L, n \geq 3\}$ is the set of m -canonical ideals of R .

Proof. 1. It is straightforward to verify that $R : M_3 = M_3 : M_3 = L[[X]]$ is quasilocal and $M_3 = X^3L[[X]]$ is not a maximal ideal of $L[[X]]$. Moreover, since $L[[X]] = R + RX + RX^2$, $\dim_k(L[[X]]/M_3) = 3$. Thus R has exactly three star operations by Theorem 4.4.2. Therefore R has exactly three (semi)star operations ([68, Proposition 3.11(2)]).

2. For each $n \geq 3$ and $a, b \in L$, $X^2 \in I_{n,a} : I_{n,a}$ and $I_{n,a} : I_{n,a}$ is an overring of $L + X^2L[[X]]$. Since $X \notin I_{n,a} : I_{n,a}$, we must have $I_{n,a} : I_{n,a} = L + X^2L[[X]]$ by Remark 4.3.14. Similarly $M_n : M_n = L[[X]]$ since $X \in M_n : M_n$ and $M_n : M_n \neq K$. $P_{n,a,b} : P_{n,a,b} = R : R = R$ and $0 : 0 = K$ follows easily.

We must show that $J_{n,a,b} : J_{n,a,b} = R$. Since $L[[X]]$ is the integral closure of R , $J_{n,a,b} : J_{n,a,b}$ a ring between R and $L[[X]]$. Moreover, $L + X^2L[[X]]$ is the only overring of R that properly lies between R and $R : M_3 = L[[X]]$ (See the proof of [37, Theorem 3.8]). Thus it suffices to show that $X^2 \notin J_{n,a,b} : J_{n,a,b}$. Assume that $X^2 \in J_{n,a,b} : J_{n,a,b}$. Then $X^2(X^n + aX^{n+2}) - aX^3(X^{n+1} + bX^{n+2}) = X^{n+2} - bX^{n+5} = X^{n+2}(1 - bX^3) \in J_{n,a,b}$, so $X^{n+2} \in J_{n,a,b}$ and $J_{n,a,b} = M_n$, which is a contradiction.

3. Since $X^3 \in R : L[[X]]$, every overring of R is of the form $I : I$ for some ideal I of R by Lemma 4.2.6. Hence the conclusion follows from Theorem 4.4.4.2.

4. Since R has three star operations by Theorem 4.4.2 and $L + X^2L[[X]]$ has three semistar operations by Remark 4.3.14, R has six semistar operations by Theorem 4.4.3. On the other hand, $d < *' < v(R)$ by [37, Theorem 2.6(1)]. Also, $R \subsetneq R^{*_{L+X^2L[[X]}}} \subsetneq R^{*_{L[[X]}}} \subsetneq R^e$. Therefore $d, *', v(R), *_{L+X^2L[[X]}}, *_{L[[X]}}$, and e are pairwise distinct semistar operations and the only semistar operations on R .

5. The fact that $R^{v(I_{n,a})} = I_{n,a} : I_{n,a} = L + X^2L[[X]] \neq R$ and $R^{v(M_n)} = M_n : M_n = L[[X]] \neq R$ implies that neither $I_{n,a}$ nor M_n is an m-canonical for each $n \geq 3, a \in L$. On the other hand, if $P_{n,a,b}$ is an m-canonical ideal for some $n \geq 3$ and $a, b \in L$, then R must be a divisorial domain, which contradicts Theorem 4.4.4. Therefore $\{J_{n,a,b} \mid n \geq 3, a, b \in L\}$ is the set of m-canonical ideals of R by Theorem 4.4.2.2. \square

Remark 4.4.5. *Given $n \geq 3$ and $a, b \in L$, $v(P_{n,a,b}) = v(R)$, $v(M_n) = *_{L[[X]}}$, $v(I_{n,a}) = *_{L+X^2L[[X]}}$, $v(J_{n,a,b}) = d = *_R$ and $v(0) = *_K$ by Theorem 4.4.4. Hence R does not have property $*$ since $*' \neq v(I)$ for each ideal I of R , but R has weak property $*$. Note that since R is a Noetherian conducive domain, it must be one-dimensional ([17, Corollary 2.7]) and $(M_3)^{v(R)} = (M_3)^{v(R)_f} = M_3$ ([21, Corollary 4.21 and Remark 4.9]). Thus $v(R) \leq v(M_3) = v(M_n)$ for each $n \geq 3$. Now given two semistar operations $*_1$ and $*_2$ of R , if $*_1 < *_2$ and there exists no semistar operation $*$ such that $*_1 < * < *_2$, place $*_2$ above $*_1$ and connect $*_1$ and $*_2$ with a node. Then we have the following tower.*

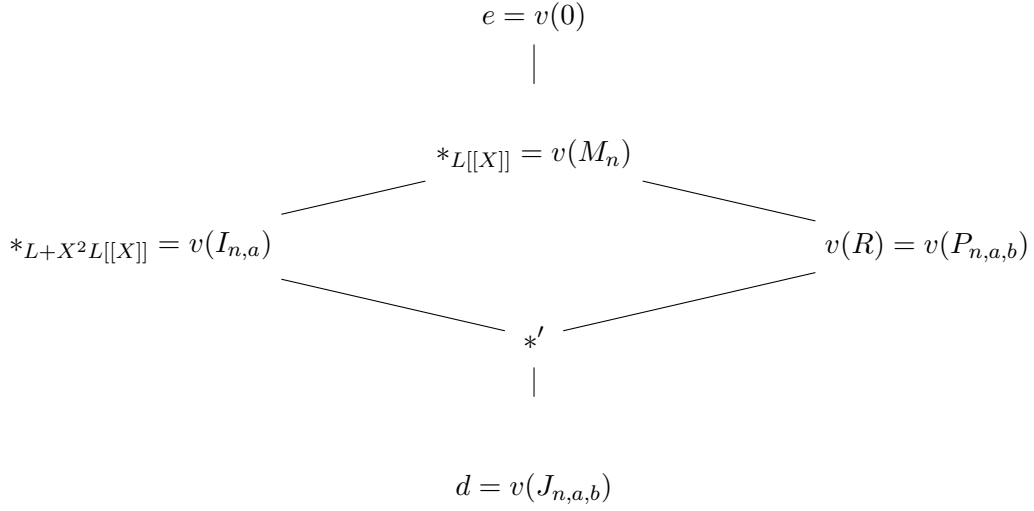

Figure 4.4.1: The tower of semistar operations on $L + X^3L[[X]]$ for each $n \geq 3$ and $a, b \in L$.

Now it follows that R is not a c^* -domain. Indeed, consider the composition map $* = v(R)*_{L+X^2L[[X]]}$. If $*$ is a semistar operation, then $* = *_{L[[X]]}$ since $*_{L[[X]]}$ is the smallest semistar operation that dominates both $v(R)$ and $*_{L+X^2L[[X]]}$ (Lemma 4.1.3.2). But $R^* = R^{v(R)*_{L+X^2L[[X]]}} = L + X^2L[[X]] \subsetneq L[[X]] = R^{*_{L[[X]]}}$, a contradiction.

4.5 When $(SStar(R), \leq)$ is a totally ordered set

We saw in Lemma 4.2.10 that a strongly discrete valuation domain is a c^* -domain. In fact, on a strongly discrete valuation domain each semistar operation is an extension to overring and each overring is totally ordered under inclusion, so the set of semistar operations is totally ordered. Moreover, any such domain must be a c^* -domain by Lemma. The next lemma gives a characterization for such domains.

Lemma 4.5.1. *Let R be an integral domain. Then the following are equivalent.*

1. $(SStar(R), \leq)$ is a totally ordered set.

2. R is a conducive domain such that

(a) $(\text{Star}(T), \leq)$ is a totally ordered set for each overring T of R .

(b) The set of overrings of R is totally ordered under inclusion.

(c) $v(T) < *_S$ for each pair of overrings $T \subsetneq S$ of R .

Proof. $1 \Rightarrow 2$: Suppose that $(\text{SStar}(R), \leq)$ is a totally ordered set. Then R is conducive by Lemma 4.2.8. Now given $T \in O(R)$ and $*_1, *_2 \in \text{Star}(T)$, $(*_1)^\iota, (*_2)^\iota \in \text{SStar}(R)$ and without loss of generality $(*_1)^\iota \leq (*_2)^\iota$. Then $I^{*1} = (IT)^{*1} = I^{(*1)^\iota} \subseteq I^{(*2)^\iota} = (IT)^{*2} = I^{*2}$ for each $I \in F(T)$, so (a) is proved. (b) Follows from the fact that $*_T \in \text{SStar}(R)$ for each $T \in O(R)$. Finally, if $T \subsetneq S$ are overrings of R then $R^{v(T)} = T \subsetneq S = R^{*S}$, and $v(T) < *_S$ by the assumption and (c) follows.

$2 \Rightarrow 1$: Suppose that 2 holds and choose two semistar operations $*_1$ and $*_2$ on R . If $R^{*1} = R^{*2} = T \in O(R)$, then $(*_i)_\iota|_{F(T)}$ are star operations on T ([69, Theorem 2.21]) and without loss of generality we may assume that $(*_1)_\iota|_{F(R)} \leq (*_2)_\iota|_{F(R)}$. Then given $I \in F(R)$, $I^{*1} = (IT)^{*1} = (IT)^{(*1)_\iota|_{F(R)}} \subseteq (IT)^{(*2)_\iota|_{F(R)}} = (IT)^{*2} = I^{*2}$. Since R is conducive, $\overline{F}(R) = F(R) \cup \{K\}$ by Theorem 4.2.6.1 and $*_1 \leq *_2$. On the other hand, if $R^{*1} \neq R^{*2}$, then without loss of generality $R^{*1} \subsetneq R^{*2}$ and $*_1 \leq v(R^{*1}) < *_{R^{*2}} \leq *_2$ by assumption. Hence $(\text{SStar}(R), \leq)$ is totally ordered. \square

From now on, we say the integral domain R is a t^* -domain (respectively, λ -domain) if $(\text{SStar}(R), \leq)$ (respectively, $(O(R), \subseteq)$) is a totally ordered set.

Let us recollect the well-known facts concerning the valuation domains. The proof is included for completeness.

Theorem 4.5.2. 1. If R is a conducive domain, then given two semistar operations $*_1$ and $*_2$, $*_1 \leq *_2$ if and only if $I^{*1} \subseteq I^{*2}$ for each nonzero ideal I of R .

2. Let R be an integral domain. TFAE.

- (a) R is a valuation domain.
- (b) $F(R)$ is totally ordered under inclusion.
- (c) $\overline{F}(R)$ is totally ordered under inclusion.

Proof. 1. ‘Only if’ implication is obvious. Suppose that $I^{*1} \subseteq I^{*2}$ for each nonzero ideal I of R . Now choose $J \in \overline{F}(R)$. We must show that $J^{*1} \subseteq J^{*2}$. Since $K^{*1} = K^{*2} = K$, we may assume that $J \neq K$. Then by Theorem 4.2.6.1, there exists nonzero $r \in R$ such that rJ is a nonzero ideal of R . Hence $rJ^{*1} = (rJ)^{*1} \subseteq (rJ)^{*2} = rJ^{*2}$ and $J^{*1} \subseteq J^{*2}$. Therefore $*_1 \leq *_2$.

2. (c) \Rightarrow (b) \Rightarrow (a) follows from definition.

(a) \Rightarrow (c): Choose $I, J \in \overline{F}(R)$. We have to show that either $I \subseteq J$ or $J \subseteq I$. If $I = K$ or $J = K$, then we have nothing to prove. Assume that $I \neq K$ and $J \neq K$. Then $I, J \in F(R)$ since R is conducive by Theorem 4.2.6. Therefore there exists nonzero $r \in R$ such that rI and rJ are ideals of R . Since R is a valuation domain, either $rI \subseteq rJ$ or $rJ \subseteq rI$. Hence either $I \subseteq J$ or $J \subseteq I$. □

Lemma 4.5.3. ([69, Proposition 2.30], [69, Proposition 2.31], [22, Proposition 4.2.5])

Let R be a valuation domain with maximal ideal M . Then

- 1. $|\text{Star}(R)| \leq 2$.
- 2. TFAE.
 - (a) R is a divisorial domain.
 - (b) $|\text{Star}(R)| = 1$.
 - (c) M is principal.
 - (d) M is divisorial.
 - (e) $M^2 \neq M$.
- 3. Given a prime ideal P of R , $|\text{Star}(R_P)| = 1$ if and only if $P^2 \neq P$.

4. If R is a nondivisorial domain, then each nondivisorial ideal of R is of the form xM for some nonzero $x \in K$.

5. For each $* \in SStar(R)$, there exists a prime ideal P of R such that either $* = v(P) = *_{R_P}$ or $* = v(R_P)$.

We are ready to prove that on a valuation domain, the set of semistar operations is totally ordered.

Theorem 4.5.4. *Each valuation domain is a c^* -domain. In fact, the following are equivalent for an integral domain R .*

1. R is a valuation domain.
2. R is an integrally closed t^* -domain.
3. R is an integrally closed λ -domain.
4. R is integrally closed and the set of valuation overrings of R is totally ordered under inclusion.

Proof. $1 \Rightarrow 2$: Let R be a valuation domain. It is well-known that R is integrally closed ([50, Theorem 10.3]). Next, we will prove that R satisfies the conditions of Lemma 4.5.1.2. It follows that R is a conducive domain by Theorem 4.2.6.2, and the set of overrings of R is totally ordered by Theorem 4.5.2.2. Moreover, the set of star operations of a valuation domain is totally ordered ([69, Proposition 2.30]) and each overring of R is a valuation domain, so Lemma 4.5.1.2(b) holds true for R . It remains to prove that (c) of Lemma 4.5.1.2 is true for R .

We first claim that $v(R) < *_{R_P}$ if P is a nonmaximal prime ideal of R (since $R_P = K$ for $P = 0$, we may assume that $P \neq 0$). Indeed, for each divisorial ideal I of R we have $I^{v(R)} = I \subseteq IR_P$. In particular, $R^{v(R)} = R \subsetneq R_P = R^{*_{R_P}}$. If I is a nondivisorial (nonzero) ideal of R , then $I = xM$ for some nonzero $x \in K$ and M is not a

divisorial ideal by Lemma 4.5.3. Thus $I^{v(R)} = (xM)^{v(R)} = xM^{v(R)} = xR \subsetneq xR_P = xMR_P = I^{*R_P}$. Hence $v(R) < *_{R_P}$ and the claim is proved. Now given two overrings $T \subsetneq S$ of R , there exists prime ideals $P \subsetneq Q$ of R so $T = R_Q$ and $S = R_P$. Then $v(T) = v(R_Q) < *_{(R_Q)_{PR_Q}} = *_{R_P} = *_{R_S}$ by the claim, so R satisfies condition (c) of 4.5.1.2. Therefore $(\text{SStar}(R), \leq)$ is a totally ordered set.

2 \Rightarrow 3: Follows from Lemma 4.2.8.7.

3 \Rightarrow 4: Trivial.

4 \Rightarrow 1: Suppose that 4 is true and Let $\{V_\alpha\}_{\alpha \in A}$ the set of valuation overrings of R . Then $R = \cap\{V_\alpha \mid \alpha \in A\}$ ([41, Theorem 57]). Now given $x \in K \setminus R$, there exists $\beta \in A$ so $x \notin V_\beta$. Then $x \notin V_\alpha$ for all $\alpha \in A$ with $V_\alpha \subseteq V_\beta$. Hence $x^{-1} \in \cap\{V_\alpha \mid \alpha \in A, V_\alpha \subseteq V_\beta\} = \cap\{V_\alpha \mid \alpha \in A\} = R$ since the set of valuation overrings of R is totally ordered under inclusion. Hence R is a valuation domain. \square

From Theorem 4.5.4 it follows that not every c^* -domain is a totally divisorial domain (for example, any non-Noetherian one-dimensional valuation domain works). On the other hand, there exists a c^* -domain that is not integrally closed (Remark 4.3.14). These two examples are actually t^* -domains. Hence one may ask whether there is a c^* -domain that is not a t^* -domain. The author was unable to answer this question, but on many classes of integral domains these two notions actually coincide. First, consider the following theorem, which is just a consequence of [65, Theorem 3.12].

Theorem 4.5.5. *Let R be an integral domain. Then the following are equivalent.*

1. R is totally divisorial.

2. R is a stable divisorial domain.

3. R is a stable domain with an m -canonical ideal.

Proof. $1 \Leftrightarrow 2$: This is exactly [65, Theorem 3.12].

$2 \Rightarrow 3$: Since R is a divisorial domain, R is an m -canonical ideal of R .

$3 \Rightarrow 2$: If I is an m -canonical ideal of R , then I is an invertible ideal of R since $I : I = R$ is a stable domain. Hence $v(I) = v(R)$ and R is a divisorial domain. \square

One may suspect that totally divisorial conducive domains are t^* -domains, and this indeed turns out to be true as we will see in the following lemmas. Moreover, it will be shown later that a totally divisorial conducive domain has only finitely many semistar operations if and only if its Krull dimension is finite (Lemma 5.3.5).

Lemma 4.5.6. (cf. [4, Lemma 2.4]) *Let R be an integral domain and M a divisorial maximal ideal of R . Then*

1. M is invertible if and only if $M : M = R$.

2. M is not invertible if and only if $R : M = M : M \supsetneq R$.

Proof. 1: If M is invertible, then clearly $M : M = R$. For the converse, suppose that M is not invertible. Then $MM^{-1} = M$ and $R : M = M : M$. If $R : M = R$, then $M^{v(R)} = R : (R : M) = R : R = R$, which contradicts the divisoriality of M . Hence $M : M \neq R$. Taking the contrapositive, we have the conclusion.

2: Follows similarly. \square

Lemma 4.5.7. *Let R be an integral domain such that*

1. *Each overring of R is either a valuation domain or a conducive quasilocal domain with noninvertible divisorial maximal ideal.*

2. $T^{v(S)} = T$ for each $S, T \in O(R)$ with $S \subseteq T$.

Then R is a λ -domain.

Proof. Suppose that there exist $S, T \in O(R)$ so $S \not\subseteq T$ and $T \not\subseteq S$. Then $U = S \cap T$ is an overring of R , and U cannot be a valuation domain since S and T are incomparable overrings of U . Hence by assumption U is a quasilocal domain with noninvertible divisorial maximal ideal N and $N : N \in O(U) \setminus \{U\}$ by Lemma 4.5.6. Now, we claim that each proper overring of U must contain $N : N = U : N$. Indeed, if $V \in O(U) \setminus \{U\}$, then $U : V \subsetneq U$ and $U : V \subseteq N$, so $N : N = U : N \subseteq V^{v(U)} = V$ by assumption. Since both S and T are proper overrings of U , it follows that $N : N \subseteq S \cap T = U$ and $U = N : N$ which contradicts Lemma 4.5.6. Hence R is a λ -domain. \square

Lemma 4.5.8. *Each totally divisorial conducive domain is a t^* -domain.*

Proof. Let R be a totally divisorial conducive domain and U an overring of R . Then U is divisorial by assumption, conducive by [17, Lemma 2.0] and quasilocal by Theorem 4.3.9 and Lemma 4.3.6. Let N be the maximal ideal of U . If $N : N = U$, then $v(N) \leq v(U)$ and N is an m -canonical ideal of U , so U is a valuation domain by Lemma 4.3.2. Otherwise, U is a conducive quasilocal domain and N is noninvertible divisorial maximal ideal of U by Lemma 4.5.6. Since each semistar operation on R is an extension to some overring (Theorem 4.3.9), it follows easily that R is a c^* -domain, so $T^{v(S)} = T$ for each $S, T \in O(R)$ with $S \subseteq T$ by Lemma 4.2.8. Hence by Lemma 4.5.7, R is a λ -domain. Since given two semistar operations $*_1, *_2$ on R , both $*_1$ and $*_2$ are extensions to overrings of R by Theorem 4.3.9, it follows that either $*_1 \leq *_2$ or $*_2 \leq *_1$. Hence R is a t^* -domain. \square

In Theorem 4.3.9 we showed that a stable domain R has property $*$ if and only if it has weak property $*$. In the following lemma we will show that a stable domain is a c^* -domain if and only if it is a t^* -domain.

Lemma 4.5.9. *Let R be an integral domain. Then the following are equivalent.*

1. R is a totally divisorial conducive domain.
2. R is a stable t^* -domain.
3. R is a stable c^* -domain.

Proof. 1 \Rightarrow 2: Follows from Theorem 4.5.5 and Lemma 4.5.8.

2 \Rightarrow 3: Follows from Lemma 4.2.8.7.

3 \Rightarrow 1: Assume that R is a stable c^* -domain. Then given a nonzero ideal I of R , $I : I$ is a divisorial fractional ideal of R by Lemma 4.2.8.3. Hence by Lemmas 2.1.9 and 4.3.10 $v(R) \leq v(I : I) = v(I)$, and I is divisorial. Therefore R is a divisorial domain, and must be a totally divisorial domain by Theorem 4.5.5. It follows that R is conducive by Lemma 4.2.8.2. □

There are nonstable domains where the set of c^* -domains and t^* -domains coincide.

Lemma 4.5.10. *1. Let R be an integral domain. Then the following are equivalent.*

- (a) R is a valuation domain.
- (b) R is a Prüfer t^* -domain.
- (c) R is a Prüfer c^* -domain.
- (d) R is a PvMD that is a c^* -domain.

2. Suppose that $|SStar(R)| < \infty$. Then R is a (finite-dimensional) valuation domain if and only if R is an integrally closed c^ -domain.*

Proof. 1. (a) \Rightarrow (b): Follows from Theorem 4.5.4.

(b) \Rightarrow (c): Follows from Lemma 4.2.8.7.

(c) \Rightarrow (d): Follows from Lemma 2.2.2 and the fact that $d \leq v$.

(d) \Rightarrow (a): Assume that R is a PvMD. Then R is integrally closed ([29, Theorem 34.6]), $t = w$ ([23, Proposition 3.1]) and $w = d$ by Lemma 4.2.8.5 and [51, Proposition 2.7(b)]. Therefore R is a Prüfer domain by [76, Theorem 8]. Now since R is a c^* -domain, each overring of R is a divisorial fractional ideal by Lemma 4.2.8. Therefore R is a valuation domain by [51, Propositions 4.1 and 4.4(3)].

2. \Rightarrow : Let R be a valuation domain. Then R is integrally closed, and R is a c^* -domain by Theorem 4.5.4 and Lemma 4.2.8.7.

\Leftarrow : Let R be an integrally closed c^* -domain. Then R is a Prüfer domain with finitely many prime ideals ([36, Theorem 4.5]). Therefore R must be a finite-dimensional valuation domain by Lemma 4.5.10.1. □

Chapter 5

Semistar operations on PVDs, Noetherian domains and Mori domains

5.1 Semistar operations on PVDs

In this section, we will briefly investigate the properties of PVDs, Noetherian domains and Mori domains in terms of semistar operations. In particular, as it is well-known that PVDs are one of the most successful generalization of valuation domains, we are interested in the classification of PVDs that are t^* -domains, as a continuation of Theorem 4.5.4. We also want to find the classes of Noetherian domains where c^* -domains are t^* -domains.

Let us begin with the definition of a PVD. Recall that a prime ideal P of R is *strongly prime* if $x, y \in K$ with $xy \in P$ implies that either $x \in P$ or $y \in P$. If every

prime ideal of R is strongly prime, then we say that R is a *Pseudo-valuation domain*, or a *PVD* for short ([31]). Let us begin with the following lemma.

Lemma 5.1.1. *1. Let P be a strongly prime ideal of an integral domain R . Then*

(a) *For each $x \in K \setminus R$, $x^{-1} \in P : P$.*

(b) *Each proper ideal of $P : P$ is also a proper ideal of R .*

(c) *$P : P$ is a valuation domain with P its unique maximal ideal. Therefore, P is an m -canonical ideal of $P : P$.*

*2. If R is a PVD, then $v(P) = *_{P:P}$ for each $P \in \text{Spec}(R)$.*

Proof. 1. (a): Follows from [31, Proposition 1.2].

(b): Let I be a proper ideal of $P : P$. If $x \in I \setminus R$, then $x^{-1} \in P : P$ and $I = P : P$ by (a), which is a contradiction. Hence I is a proper ideal of R .

(c): The fact that $P : P$ is a valuation domain follows from (a). Since $(P : P)P = P$, P is an ideal of $P : P$. Now let $x \in (P : P) \setminus P$. Then for any $a \in P$, $(\frac{a}{x})x \in P$ and $\frac{a}{x} \in P$ since P is strongly prime. Therefore $x^{-1}P \subseteq P$ and $x^{-1} \in P : P$. Thus P is the unique maximal ideal of $P : P$, and must be an m -canonical ideal of $P : P$ by Lemma 4.3.2.

2: By 1(c), P is an m -canonical ideal of $P : P$. Since a PVD is conducive ([17, Proposition 2.1]), we have $v(P) = *_{P:P}$ for each prime ideal P by [69, Proposition 2.34]. □

Remark 5.1.2. *Note that the converse of Lemma 5.1.1.2 is false. Indeed, let (R, M) be the domain from Remark 4.3.14. Then $v(M) = *_{M:M}$ since $M : M = L[[X]]$ is a divisorial domain. On the other hand, M is not a strongly prime ideal since $X^2 \in M$ but $X \notin M$.*

The following are well-known.

Theorem 5.1.3. 1. ([31, Proposition 2.10], [4, Lemma 2.4]) Let R be a quasilocal domain with maximal ideal M that is not a valuation domain. Then R is a PVD if and only if $M : M$ is a valuation domain with maximal ideal M .

2. ([4, Proposition 2.6]) Let V be a valuation domain with maximal ideal M and L is a subfield of V/M . Then the domain R arises from the following pullback is a PVD, where the map $\phi : V \rightarrow V/M$ is the canonical surjection. Conversely, every PVD R with maximal ideal M that is not a valuation domain arises from the pullback. In that case, $L = R/M$ and V is the associated valuation domain with maximal ideal M .

$$\begin{array}{ccc} R & \longrightarrow & L \\ \downarrow & & \downarrow \\ V & \xrightarrow{\phi} & V/M \end{array}$$

3. ([52, Corollary 3.5]) Let R be a PVD with maximal ideal M that is not a valuation domain. Let $V = M : M$. Then R is divisorial if and only if $[V/M : R/M] = 2$.

Corollary 5.1.4. Let R be a PVD with maximal ideal M and associated valuation domain V . Then $R_P = V_P$ for each nonmaximal prime ideal P .

Proof. Since $V = M : M$ by Theorem 5.1.3.1, $R_P \subseteq V_P = (M : M)_P \subseteq M_P : M_P = R_P : R_P = R_P$ for each nonmaximal prime ideals P of R . \square

Park thoroughly investigated the cardinality of star operations on a PVD and proved the following, among many other interesting results ([67, Lemmas 2.1 and 2.2, Proposition 2.4, Theorems 2.5 and 2.6, Remark 2.9]);

Lemma 5.1.5. Let R be a PVD with maximal ideal M and V its associated valuation overring. Then

1. Let I be a nonzero divisorial fractional ideal of R . If $R \subseteq I \subseteq V$, then either $I = R$

or $I = V$.

2. If I is a nonzero nondivisorial ideal of R , then there exists nonzero $a \in I$ such that $R \subsetneq a^{-1}I \subsetneq V$.

3. (a) Given two fractional ideals I and J of R , define a relation \sim by $I \sim J$ if and only if $I = aJ$ for some nonzero $a \in K$. Then \sim is an equivalence relation on the set of fractional ideals of R .

(b) If $I \sim J$, then either I and J are both divisorial or both nondivisorial.

(c) Let the relation \sim' be define on the set of L -vector spaces between L and V/M by $U \sim' W$ if and only if $U = bW$ for some nonzero $b \in V/M$. Then \sim' is an equivalence relation and $U \sim' W$ if and only if $\phi^{-1}(U) \sim \phi^{-1}(W)$.

(d) If I is a nondivisorial ideal, then $I \sim J$ for some J lying properly between R and V . In this case, we define the rank of I to be $\dim_L \phi(J)$. Then it is independent of the chopice of J ; hence, well-defined.

4. Assume that $\dim_L(V/M) = n \geq 3$. Then for each integer m with $2 \leq m < n$, let X_m be the complete set of class representatives under \sim on the set of fractional ideals of R of rank m . Now for given $2 \leq m < n$ and $S \subset X_m$, the map $*_S : F(R) \rightarrow F(R)$ defined by

$$I \mapsto I^{*S} = \begin{cases} I, & \text{if } I \in \cup\{X_r \mid r < m\} \cup S \\ I^{v(R)}, & \text{otherwise} \end{cases}$$

is a star operation on R . Moreover, for a fixed m , distinct subset S of X_m gives a distinct $*_S$.

5. $|Star(R)| \leq 2$ if and only if $\dim_L(V/M) \leq 3$.

6. If $\dim_L(V/M) = n \geq 4$, then $|X_2| \geq \lfloor n/2 \rfloor$, where $\lfloor n/2 \rfloor$ is the largest integer less than or equal to $n/2$.

Another characterization of valuation domain is as follows.

Lemma 5.1.6. *Let R be an integral domain. Then the following are equivalent.*

1. R is a valuation domain.
2. R is an integrally closed PVD with at most two star operations.

Proof. 1 \Rightarrow 2: Follows from [50, Theorem 10.3], [31, Proposition 1.1] and Lemma 4.5.3.

2 \Rightarrow 1: Assume that 2 holds. Recall that every PVD is a quasilocal domain ([31, Corollary 1.3]). Thus R is a (quasilocal) Prüfer domain by [35, Theorem 3.3], so it must be a valuation domain. □

We have already seen that a valuation domain is t^* -domain (Theorem 4.5.4) that has property $*$ (Theorem 4.3.1) and has at most two star operations (Lemma 4.5.3). Therefore we may conjecture that those types of domains are closely related to each other, and indeed, the following lemma shows that a PVD must have either all or none of the properties mentioned above.

Lemma 5.1.7. *Let R be a PVD. Then the following are equivalent.*

- (a) $|\text{Star}(R)| \leq 2$.
- (b) R is a t^* -domain.
- (c) R has property $*$.

Proof. We denote the maximal ideal of R by M and the associated overring by V , as usual.

(a) \Rightarrow (b): If R is a valuation domain, then the conclusion follows from Theorem 4.3.1 and Theorem 4.5.4. Let R be a PVD that is not a valuation domain and $|\text{Star}(R)| \leq 2$. Then $V = M : M$ is a valuation domain with maximal ideal M ([31, Theorem 2.10]), and $[V/M : R/M] \leq 3$ by Lemma 5.1.5.5. But then $O(R) = \{R\} \cup O(V)$ ([51, Theorem

4.5]). Thus R is a λ -domain and R is conducive ([17, Proposition 2.1]). Also, since $|\text{Star}(T)| \leq 2$ for each $T \in O(R)$, $(\text{Star}(T), \leq)$ is a totally ordered set for each $T \in O(R)$. Moreover, $v(R) < *_V$. Indeed, for a (nonzero) principal ideal I of R , $I^{v(R)} = I \subsetneq IV$. For nonprincipal ideal I of R , $I^{v(R)} = IV$ by [31, Proposition 2.14]. Hence $v(R) < *_V$ by Theorem 4.5.2. This, combined with Theorem 4.5.4 and Corollary 5.1.4, yields that $T \subsetneq S$ implies $v(T) < *_S$ for $S, T \in O(R)$. Therefore R is a t^* -domain by Lemma 4.5.1.

(b) \Rightarrow (a): If $|\text{Star}(R)| > 2$, then $|X_2| \geq 2$ by 5 and 6 of Lemma 5.1.5 and we can choose distinct $I_1, I_2 \in X_2$. Given $i \in \{1, 2\}$, set $S_i = \{I_i\}$. Then $(I_1)^{*_S_2} = (I_1)^{v(R)} \supsetneq I_1 = (I_1)^{*_S_1}$ and $(I_2)^{*_S_1} = (I_2)^{v(R)} \supsetneq I_2 = (I_2)^{*_S_2}$, so $*_{S_1} \not\leq *_{S_2}$ and $*_{S_2} \not\leq *_{S_1}$. Hence R is not a t^* -domain. Taking the contrapositive, we have the desired result.

(a) \Rightarrow (c): Suppose that (a) is true. Given a semistar operation $*$ on R such that $R^* \neq R$, $R^* = V_P = R_P$ for some nonmaximal prime ideal P of R by Corollary 5.1.4. Since R_P is a valuation domain, either $* = v(P)$ or $* = v(R_P)$ by Lemma 4.5.3.5. On the other hand, if $R^* = R$, then either $* = d$ or $* = v(R)$ by assumption and the fact that R is conducive. Note that given an ideal I of R , $d \neq v(I)$ implies $v(R) \leq v(I)$ since R is a t^* -domain. Then $I^{v(R)} = I$ by 2.1.9, and this means that if R does not have a proper m-canonical ideal, then R is a divisorial domain. But then $v(R) = d$ by Theorem 4.5.2.1. Therefore R has an m-canonical ideal I , and $d = v(I)$. Thus R has property $*$.

(c) \Rightarrow (a): Assume that (c) holds. We first claim that for each $S \subset X_2$, $*_S = v(I)$ for some $I \in S$. Indeed, we must have $*_S = v(J)$ for some nonzero ideal J by assumption. Now $J^{*_S} = J^{v(J)} = J$, so either $J \sim I$ for some $I \in S$ or J is divisorial by Lemma 5.1.5.4. If J is divisorial, then $*_S = v(R)$, and S consists of divisorial ideals, which contradicts Lemma 5.1.5.1 since X_2 consists of nondivisorial ideals. Hence $J \sim I$ for

some $I \in S$ and $J = aI$ for some nonzero $a \in K$. Now $v(J) = v(I)$ and $*_S = v(I)$. Hence the claim is proved. Now if $|\text{Star}(R)| > 2$, then $|X_2| \geq 2$ by 5 and 6 of Lemma 5.1.5 and we can choose distinct $I_1, I_2 \in X_2$. Given $i \in \{1, 2\}$, set $S_i = \{I_i\}$ and $T = \{I_1, I_2\}$. Then we must have $*_{S_i} = *_T = v(I_i)$ for some $i \in \{1, 2\}$ by the claim, which contradicts the second assertion of Lemma 5.1.5.4. \square

Remark 5.1.8. *Lemma 5.1.7 sharpens both Theorem 4.3.1 and Theorem 4.5.4.*

From now on, given a PVD R with maximal ideal M a *valuation overring associated to R* will denote the valuation overring $M : M$.

Remark 5.1.9. *Even a totally divisorial PVD may not be a valuation domain. For example, consider $R = \mathbb{Q} + X\mathbb{Q}(\sqrt{2})[[X]]$, $M = X\mathbb{Q}(\sqrt{2})[[X]]$, K the quotient field of R and $V = \mathbb{Q}(\sqrt{2})[[X]]$. Then $O(R) = \{T + M \mid T \text{ is a ring such that } \mathbb{Q} \subseteq T \subseteq \mathbb{Q}(\sqrt{2})\} \cup \{V, K\} = \{R, V, K\}$ by [12, Theorem 3.1]. It follows that M is the unique maximal ideal of R ([12, Theorem 2.1]) and R is a PVD with maximal ideal M by ([31, Theorem 2.7]). Moreover, since $[V/M : R/M] = [\mathbb{Q}(\sqrt{2}) : \mathbb{Q}] = 2$, R is divisorial by Theorem 5.1.3. V is a Noetherian valuation domain, so it must be divisorial. Hence R is a totally divisorial PVD, but it is not a valuation domain ([8, Theorem 2.1 (e)]).*

Recall that an ideal I of R is said to be *recurrent* if $R : (I : I) = I$ ([60]). Recall that I is *strong* if $I(R : I) = I$ and *strongly divisorial* if I is strong and divisorial([9]). The next lemma shows that an ideal is recurrent if and only if it is strongly divisorial.

Lemma 5.1.10. *Let R be an integral domain. Then*

1. *An ideal I of R is strongly divisorial if and only if it is recurrent.*
2. *Let R be a PVD with maximal ideal M that is also a c^* -domain. If R is not a valuation domain, then $\text{Spec}(R) \cup \{R\}$ is the set of recurrent ideals of R and $O(R) = \{R\} \cup O(V)$ where $V = M : M$.*

Proof. 1. Let I be a strongly divisorial ideal. Then since $I(R : I) = I$, we have $R : I = I : I$. Hence $R : (I : I) = R : (R : I) = I$ and I is recurrent. Conversely, if I is a recurrent ideal of R , then $R : (R : I) \subseteq R : (I : I) = I$, so I is a divisorial ideal. Therefore $v(R) \leq v(I)$ by Lemma 2.1.9.2, and $R : I = R : (R : (I : I)) = R^{v(I)v(R)} = R^{v(I)} = I : I$ by Lemma 2.1.8(c), so $I(R : I) = I(I : I) = I$. Therefore I is strongly divisorial.

2. Since R is a c^* -domain, every overring of R is a divisorial fractional ideal by Lemma 4.2.8. Now the conclusion follows from [51, Proposition 4.1] and [51, Theorem 4.5]. \square

We also have the characterization of PVDs with weak property $*$.

Theorem 5.1.11. *Let R be a PVD with maximal ideal M and $R \subsetneq V = M : M$. Then the following are equivalent.*

1. R has weak property $*$.
2. Given an overring T of R , T is a PVD with maximal ideal M_T and valuation ring $V_T = M_T : M_T$ such that $[V_T/M_T : T/M_T] < \infty$.
3. $[V/M : R/M] < \infty$.
4. R has an m -canonical ideal.

Proof. By Corollary 4.3.8, [3, Corollary 2.2] and [11, Theorem 3.1]. \square

5.2 Integral domains having four semistar operations

Mimouni and Samman classified integral domains having precisely three semistar operations ([54, Proposition 15]). In this section, we attempt to find a similar classification for integral domains that possess exactly four semistar operations. First recall the following well-known results.

Lemma 5.2.1. *Let R be an integral domain.*

1. *The following are equivalent.*

(a) $|O(R)| = 1$.

(b) $|SStar(R)| = 1$.

(c) R is a field.

2. *The following are equivalent.*

(a) $|O(R)| = 2$.

(b) R is a one-dimensional valuation domain.

3. *The following are equivalent.*

(a) $|SStar(R)| = 2$.

(b) R is a Noetherian valuation domain.

4. *The following are equivalent.*

(a) $|SStar(R)| = 3$ and $|O(R)| = 2$.

(b) R is a one-dimensional non-Noetherian valuation domain.

Proof. 1. (a) \Rightarrow (b): If $|O(R)| = 1$, then $R = K$ and $xR = xK = K$ for each nonzero $x \in K$. Thus $* = e$ for each semistar operation $*$ on R .

(b) \Rightarrow (c): If R has only one semistar operation, then $R = R^d = R^e = K$.

(c) \Rightarrow (a): Clear.

2. By [50, Exercise 10.5].

3. By [70, Theorem 2.7].

4. (a) \Rightarrow (b): Follows from 2 and 3.

(b) \Rightarrow (a): Assume that (b) is true. Then $|O(R)| = 2$ by 2, and $|\text{SStar}(R)| = |\text{Star}(R)| + |\text{SStar}(K)|$ by Theorem 4.4.3 since a valuation domain is conducive and quasilocal. $|\text{SStar}(K)| = 1$ follows from 1. Since R is non-Noetherian, M is nonprincipal and $|\text{Star}(R)| = 2$ by Lemma 4.5.3 and $|\text{SStar}(R)| = 3$. \square

The following lemma gives a classification of domains with four semistar operations. Note that it tells us that any integral domain that has exactly four semistar operations is either totally divisorial or a PVD.

Lemma 5.2.2. *Let R be an integral domain. Then R has exactly four semistar operations if and only if one of the following holds;*

(a) $|O(R)| = 4$ and R is a totally divisorial conducive domain.

(b) R is a two-dimensional valuation domain with exactly one idempotent nonzero prime ideal (recall that an ideal I of a commutative ring R is called idempotent if $I^2 = I$).

(c) R is a divisorial PVD with one-dimensional non-Noetherian valuation domain as its associated valuation overring.

(d) R is a Noetherian quasilocal domain that has two star operations. In this case R is a PVD.

Moreover, any integral domain that has exactly four semistar operations is a t^* -domain and has property $*$.

Proof. \Rightarrow : Suppose that $|\text{SStar}(R)| = 4$. If $|O(R)| \leq 2$, then $|\text{SStar}(R)| \leq 3$ by Lemma 5.2.1, a contradiction. Hence $|O(R)| \geq 3$. On the other hand, if $|O(R)| \geq 5$ so there exists distinct overrings T_1, \dots, T_5 of R , then $\{*_T_i \mid 1 \leq i \leq 5\}$ is a set of distinct semistar operations and $|\text{SStar}(R)| \geq 5$, another contradiction. Therefore $|O(R)| \leq 4$.

If $|O(R)| = 3$ with $O(R) = \{R \subsetneq T \subsetneq K\}$, then $O(R)$ is totally ordered under inclusion. Therefore $\text{Spec}(R)$ is totally ordered. In particular, R is quasilocal with a unique

maximal ideal M . It also follows that $\dim(R) \leq 2$, since if R has an ascending chain of three prime ideals, then the localization of R at each of those prime ideal would form four distinct overrings, which is a contradiction. Finally, since $|O(T)| = 2$, T is a one-dimensional valuation domain by Lemma 5.2.1.2.

(a): Now consider the case when $|O(R)| = 4$. Then there are four semistar operations that are extension to overrings of R , and they must be the only semistar operations on R . Hence R is totally divisorial and conducive and has property $*$ by Theorem 4.3.9. Moreover, R is a t^* -domain by Lemma 4.5.8.

(b): Assume that $|O(R)| = 3$ and R is integrally closed. Then by Theorem 4.5.4 R must be a valuation domain. Moreover, R is two-dimensional by [51, Theorem 2.5 (1)]. Let P be the nonzero nonmaximal prime ideal of R . Hence $|\text{SStar}(R)| = |\text{Star}(R)| + |\text{SSStar}(R_P)|$ by Theorem 4.4.3. Thus $|\text{Star}(R)| = 1$ and $|\text{SSStar}(R_P)| = 3$ or $|\text{Star}(R)| = 2$ and $|\text{SSStar}(R_P)| = 2$. Assume the former. Then $M \neq M^2$ and $P^2 = P$ by Lemma 4.5.3. Similarly, $M = M^2$ and $P \neq P^2$ for the latter. Thus R is a two-dimensional valuation domain with exactly one nonzero idempotent prime ideal.

(c): Assume that $|O(R)| = 3$ and R is not integrally closed. Then T must be the integral closure of R , and R must be one-dimensional. Now assume that R is a divisorial domain. Then since R is not a valuation domain, it follows that $M : M \neq R$ by Lemma 4.3.2. Therefore $M : M = T$ must be the integral closure of R . Since $R : (M : M) = M \neq 0$, it also follows that R is a conducive domain by Theorem 4.2.6. Now $|\text{Star}(R)| + |\text{SSStar}(M : M)| = |\text{SSStar}(R)| = 4$ by Theorem 4.4.3, and

$|\text{SSStar}(M : M)| = 3$. Since $|O(M : M)| = 2$, $M : M$ is a non-Noetherian valuation domain by Lemma 5.2.1.4. It also follows that R must be a PVD. Indeed, suppose that M is not the maximal ideal of $M : M$. Then by [13, Theorem 5.7], $N^2 \subseteq M \subsetneq N$, where N is the maximal ideal of $M : M$. But then $M : M$ is a divisorial domain by Lemma 4.5.3.2, and must be a Noetherian valuation domain, a contradiction. Hence M is the maximal ideal of $M : M$ and R must be a PVD ([31, Theorem 2.10]). It is a t^* -domain with property $*$ by Lemma 5.1.7.

(d): Finally, suppose that $|O(R)| = 3$ and R is neither integrally closed nor divisorial. Then $|\text{Star}(R)| \geq 2$ and $|\text{SSStar}(T)| \geq 2$ where T is the overring other than R and K . On the other hand, $|\text{Star}(R)| + |\text{SSStar}(T)| \leq |\text{SSStar}(R)| = 4$ (Theorem 4.4.3) and we must have $|\text{Star}(R)| = |\text{SSStar}(T)| = 2$. Therefore R is a conducive quasilocal domain by Theorem 4.4.3 and T is a Noetherian valuation domain by Lemma 5.2.1. Moreover, R must be a one-dimensional domain since T is the integral closure of R . We claim that M is a divisorial ideal. If not, then $M^{v(R)} = R$ and $R = M : M = R : M$, so $R^{v(M)} = R$ and $v(M) \leq v(R)$ by Lemma 2.1.9. Since M is not divisorial, $v(M) \neq v(R)$ by Lemma 2.1.9 and we must have $v(M) = d$. But then M is an m -canonical ideal and R is a valuation domain by Lemma 4.3.2, a contradiction.

Hence $v(M) \neq d$ and either $v(M) = v(R)$ or $v(M) = *_{T}$. If $v(M) = v(R)$, then M must be invertible by Lemma 4.5.6. Thus $M = mR$ for some $m \in R$ ([41, Theorem 59]). Since R is a one-dimensional domain, we must have $\bigcap_{n \in \mathbb{N}} m^n R = 0$ ([56, Corollary 1.4]). Therefore given a nonzero $x \in R$, there exists a unique $n \in \mathbb{N}_0$ so $x \in m^n R \setminus m^{n+1} R$. Then $x = m^n u$ for some unit u of R , and the map $x \mapsto n$ defines a discrete valuation ν on K such that $R = \{x \in K \mid \nu(x) \geq 0\}$. But then R is a Noetherian valuation

domain, which is a contradiction. Hence M is not invertible and $v(M) \neq v(R)$, and $v(M) = *_T$. Therefore, from the fact that M is divisorial, we have $v(R) \leq v(M) = *_T$ by Lemma 2.1.9. Thus $d < v(R) < *_T < e$ and R is a t^* -domain. Finally, R has an m -canonical ideal. If not, then $v(I) \geq v(R)$ for each nonzero ideal I of R and I is divisorial by Lemma 2.1.9, which contradicts the assumption that R is not a divisorial domain. Therefore R has property $*$. To show that R is a Noetherian domain, we claim that R has a nonzero finitely generated ideal that is not a divisorial ideal of R . Indeed, if not, then for any $x \in T \setminus R$, $(1, x)R$ is a divisorial (fractional) ideal of R . Now $R \subseteq (1, x)R \subseteq T$, and $M = R : T \subseteq R : (1, x)R \subseteq R$, so $M = (1, x)R$ since $(1, x)R \neq R$. Thus $T = R : M = ((1, x)R)^{v(R)} = (1, x)R$, so T is a finitely generated R -module. But then since T is a Noetherian domain, R must be a Noetherian domain by Eakin-Nagata theorem. Therefore $v(R) = v(R)_f = d$ and R is divisorial, which is a contradiction. Hence there must be a finitely generated nondivisorial ideal I of R . Since $v(R) \not\leq v(I)$ by Lemma 2.1.9, we must have $v(I) = d$ and I is a finitely generated m -canonical ideal I . Then T is a finite R -module by [11, Corollary 2.5]. Thus again by Eakin-Nagata theorem R must be a Noetherian domain. The fact that R is a PVD follows from [35, Theorem 4.1.3] and [31, Theorem 2.10].

\Leftarrow : Suppose that R is one of (a), (b), (c) and (d).

(a): If R is totally divisorial and conducive with $|O(R)| = 4$, then since each semistar operation on R is extension to overring by Theorem 4.3.9, R has four semistar operations.

(b): Let R be a two-dimensional valuation domain with exactly one nonzero idempotent prime ideal. Then $|\text{SStar}(R)| = |\text{Star}(R)| + |\text{SStar}(R_P)|$ by Theorem 4.4.3. Now the conclusion follows from Lemma 4.5.3.3.

(c): If R is a divisorial PVD whose associated valuation overring is a one-dimensional non-Noetherian domain V , then $[V/M : R/M] = 2$ by [67, Theorem 2.15(1)], so $O(R) = \{R\} \cup O(V) = \{R, V, K\}$ by [51, Theorem 4.5]. Moreover, R is conducive ([17, Proposition 2.1]). Therefore $|\text{SStar}(R)| = |\text{Star}(R)| + |\text{SStar}(V)| = 1 + 3 = 4$ by Theorem 4.4.3.

(d): If R is a Noetherian quasilocal domain with maximal ideal M that has two star operations, then $V = M : M$ is a Noetherian valuation domain, $O(R) = \{R, V, K\}$, $[V/M : R/M] = 3$ and M is the maximal ideal of V by [35, Theorem 4.1]. Thus R is a PVD by [31, Theorem 2.10]. Hence R is conducive and $|\text{SStar}(R)| = |\text{Star}(R)| + |\text{SStar}(V)| = 2 + 2 = 4$. \square

Let us provide the examples of the domains that have exactly four semistar operations, as described in Lemma 5.2.2.

Example 5.2.3. *Recall that given a nonzero field L there exists a one-dimensional non-Noetherian valuation domain V with maximal ideal M such that $V = L + M$. Indeed, let L be a field, α an irrational number and X, Y indeterminates over L . Then the map $\phi: L[X, Y] \rightarrow \mathbb{R} \cup \{\infty\}$ defined by $\phi(\sum_{n,m \geq 0} c_{n,m} X^n Y^m) = \min\{n + m\alpha \mid c_{n,m} \neq 0\}$ determines a valuation of $L(X, Y)$ with value group $\mathbb{Z} + \alpha\mathbb{Z}$ ([45, Exercise 10.11]). Let V be the valuation domain of $L(X, Y)$ that corresponds to this valuation. Then since the value group of V is a subgroup of \mathbb{R} that is not isomorphic to \mathbb{Z} , V is a one-dimensional*

non-Noetherian valuation domain ([45, Theorem 10.7]). Moreover, $V = L + M$ where M is the maximal ideal of V ([29, Exercise 20.12]).

(a) Consider $L[[X^2, X^5]]$ where L is a field and X is an indeterminate. Then it is a totally divisorial conducive domain with four overrings and four semistar operations (Lemma 5.3.7).

(b) Let V be the valuation domain described in the beginning of this example and set F be the quotient field of V . Then choose an indeterminate W and set $T = F[[W]]$ and $N = WT$. Now $R = V + N$ is a two-dimensional non-divisorial valuation domain with $\text{Spec}(R) = \{0, N, M + N\}$ by [12, Theorem 2.1, Corollary 4.4]. Now $M + N$ is an idempotent ideal and $R_N = T$ is a Noetherian valuation domain, so $N^2 \neq N$. On the other hand, if $L = \mathbb{Q}(Z)$ for some indeterminate Z , then given a one-dimensional non-Noetherian valuation domain $V = L + M$, $S = \mathbb{Q}[[Z]] + M$ is a two-dimensional valuation domain with $\text{Spec}(R) = \{0, M, M + ZL\}$ by [12, Theorem 2.1, Corollary 4.4]. It follows that $M^2 = M$ and $(M + ZL)^2 \neq M + ZL$.

(c) Let $L = \mathbb{Q}(\sqrt{2})$, $V = L + M$ a one-dimensional non-Noetherian valuation domain with maximal ideal M and set $R = \mathbb{Q} + M$. Then R is a divisorial PVD with V its associated valuation overring by Theorem 5.1.3.

(d) Let $V = \mathbb{Q}(\sqrt[3]{2})[[X]]$, where X is an indeterminate. Set $M = XV$ and $R = \mathbb{Q} + M$. Then R is a Noetherian PVD with maximal ideal M and associated valuation overring V by Theorem 5.1.3, and $[V/M : R/M] = 3$. Hence $|\text{Star}(R)| = 2$ ([67, Theorem 2.6]).

5.3 On Mori c^* -domains and totally divisorial conducive domains

Recall that an integral domain R is called a *Mori domain* if it has the ascending chain condition on divisorial ideals of R . The next lemma shows that the overrings of a Mori c^* -domain behave nicely.

Lemma 5.3.1. *Let R be a Mori c^* -domain. Then R is a one-dimensional λ -domain, and $O(R)$ is a finite set.*

Proof. It follows that by Lemma 4.2.8.4 and [51, Proposition 4.1 and Corollary 4.2] that R is a one-dimensional quasilocal domain and either R is a Noetherian valuation domain or R has a strongly divisorial maximal ideal M and $M : M \subseteq T$ for each $T \in O(R) \setminus \{R\}$ where M is the maximal ideal of R . In other words, either R is a DVR or $M : M$ is the unique minimal (proper) overring of R . Moreover, $M : M$ is a Mori c^* -domain ([10, Proposition 15], Lemma 4.2.8.4). Now set $R_0 = R$, $M_0 = M$ and $R_{n+1} = M_n : M_n$, where M_n is the maximal ideal of R_n . Then $\{R_n\}_{n \geq 0}$ is an ascending chain of $O(R)$ consisting of Mori c^* -domains. Since R has ascending chain property on $O(R)$ ([51, Corollary 4.3]), $R_n = R_{n+1}$ for some $n \in \mathbb{N}$. Such R_n must be a Noetherian valuation domain by above argument. Choosing n to be the smallest such number, it is straightforward to verify that $O(R) = \{R_i\}_{i=0}^n \cup \{K\}$. \square

Corollary 5.3.2. *Let R be an integral domain. Then R is an integrally closed Mori c^* -domain if and only if it is a Noetherian valuation domain.*

Proof. \Rightarrow : The fact that R is a valuation domain follows from Theorem 4.5.4 and Lemma 5.3.1. Now R is Noetherian by [71, Corollary 2].

\Leftarrow : Let R be a Noetherian valuation domain. Then R is clearly an integrally closed Mori domain, and R is a c^* -domain by Theorem 4.5.4 and Lemma 4.2.8.7. \square

Remark 5.3.3. *Note that the condition ‘integrally closed’ in Corollary 5.3.2 cannot be replaced by ‘seminormal’ (an integral domain is seminormal if for each $x \in K$ such that $x^2 \in R$ and $x^3 \in R$, $x \in R$). Indeed, the integral domain described in Lemma 5.2.2 is a PVD, which is a seminormal ([5, Proposition 3.1(a)]) Noetherian t^* -domain, but it is not a valuation domain.*

Lemma 5.3.4. *A divisorial Noetherian PVD is totally divisorial. Moreover, it has at most three semistar operations.*

Proof. Let R be a divisorial Noetherian PVD. Then by Lemma 5.1.7 and Lemma 4.2.8.7, R is a c^* -domain. Hence R is a one-dimensional domain by Lemma 5.3.1. Moreover, $O(R) = \{R, M : M, K\}$ where M is the maximal ideal of R . Hence it suffices to show that $M : M$ is a divisorial domain. If R is a valuation domain, then $M : M = R$ is a Noetherian valuation domain and $|\text{SSStar}(R)| = 2$ by Lemma 5.2.1. Suppose that R is not a valuation domain. Now $[V/M : R/M] = 2$ where $V = M : M$ is the associated valuation overring of R . It follows that V is a Noetherian valuation domain since V is a finite R -module. Hence R is totally divisorial and $|\text{SSStar}(R)| = |O(R)| = 3$. \square

Next, we prove that on a quasilocal Noetherian domain with infinite residue field that has only finitely many semistar operations, c^* -domains are actually t^* -domains. Moreover, it is ‘almost totally divisorial’ in some sense.

Lemma 5.3.5. *Let R be a Noetherian c^* -domain. Then R is a λ -domain and $O(R)$ is a finite set that consists of Noetherian c^* -domains. Moreover, if the residue field of R is infinite and $\text{Star}(R)$ is a finite set, then R is a t^* -domain and at most one overring*

of R is a nondivisorial domain. Such nondivisorial domain, if it exists, must be a PVD that has exactly two star operations.

Proof. The first assertion follows from Lemma 5.3.1,[10, Corollary 7] and Lemma 4.2.8.4. Now assume that R/M is an infinite set and $\text{Star}(R)$ is a finite set. Then by [38, Theorem 1.13], only one of the following three cases happen;

- (a). R is a Noetherian valuation domain.
- (b). $\dim_{R/M}(M : M/M) = 2$ and R is a divisorial domain.
- (c). $\dim_{R/M}(M : M/M) = 3$ and R is a PVD with exactly two star operations.

If R is a Noetherian valuation domain then we have nothing to prove. Assume that $\dim_{R/M}(M : M/M) = 2$ and R is a divisorial domain. Then the residue field of $M : M$ is infinite by [38, Theorem 2.4]. On the other hand, if $\dim_{R/M}(M : M/M) = 3$ and R is a PVD with exactly two star operations, then the associated valuation overring V is Noetherian, and it must be the domain described in Lemma 5.2.2(d). Hence from the induction on $|O(R)|$, we have that R is a t^* -domain and at most one overring of R is nondivisorial. □

The following lemma provides a way to count the total number of semistar operations on a totally divisorial conducive domain.

Lemma 5.3.6. *Let R be a totally divisorial conducive domain. Then R' is a finitely generated R -module and $|O(R)| = |S\text{Star}(R)| = l(R'/R) + \dim(R) + 1$. In particular, R has only finitely many semistar operations if and only if the Krull dimension of R is finite. Moreover, $R = R_0 \subsetneq R_1 \subsetneq \cdots \subsetneq R_n = R'$ forms a composition series of R -modules, where $\{R_i\}_{0 \leq i \leq n}$ is the set of overrings of R that is contained in R' .*

Proof. Note first that the equality $|S\text{Star}(R)| = |O(R)|$ follows from Theorem 4.3.9. Set $R_0 = R$ and $M_0 = M$. Then inductively define $R_{n+1} = M_n : M_n$ for each $n \in \mathbb{N}$, where

M_n is the unique maximal ideal of R_n . We now claim that $n(R) = \inf\{r \in \mathbb{N}_0 \mid R_r = R_{r+1}\}$ is a finite number. Indeed, when R is Noetherian, we have $|O(R)| = n(R) + 2$ and $n(R)$ is finite by the proof of Lemma 5.3.1. Moreover, $\dim(R) = 1$ by [17, Corollary 2.7]. Hence $|O(R)| = |SStar(R)| = n(R) + \dim(R) + 1$.

Consider the case when R is non-Noetherian. Then the Krull dimension of R is at least 2 ([13, Proposition 7.1]). Now by [65, Lemma 3.10], $R' = R_r$ for some $r \in \mathbb{N}$, and $O(R) = \{R_1, \dots, R_r\} \cup \{R_P \mid P \in \text{Spec}(R)\}$. Again, it follows that $n(R) = r < \infty$ and $\text{Spec}(R)$ is totally ordered under inclusion by Lemma 4.3.6.3 and Theorem 4.3.9. Thus $|O(R)| = n(R) + \dim(R) + 1$.

It remains to show that $n(R) = l(R'/R)$. It suffices to show that R_n/R_{n-1} is a simple R module for $n = 1, 2, \dots, n(R)$. But this follows from the proof of [13, Proposition 6.1]. □

The domain described in the following lemma is a well-known example of nonintegrally closed totally divisorial conducive domains, and finding the number of its semistar operations is easy.

Lemma 5.3.7. *Let L be a field, X an indeterminate and $R_n = L[[X^2, X^{2n+1}]]$ for each $n \in \mathbb{N}_0$. Then*

1. *Each semistar operation on R_n is an extension to some overring of R_n .*
2. *$O(R_n) = \{R_i\}_{i=0}^n \cup \{K\}$ where K is the quotient field of R_0 . Therefore $SStar(R_n) = \{*_R_i\}_{i=0}^n \cup \{e\}$ is totally ordered under \leq .*

Proof. 1. Given $n \in \mathbb{N}_0$, each ideal of R_n can be generated by at most two elements ([73, Proposition 3.4]), so R_n is a (Noetherian) totally divisorial domain ([8, Proposition 4.8]). On the other hand, since $R_0 = L[[X]]$ is a valuation overring of R_n and $R_n : R_0 = X^{2n+1}R_0 \neq 0$, R_n is conducive by Theorem 4.2.6. Hence the conclusion follows from

Theorem 4.3.9.

2. Since $L[[X]] = R'_n = R_n + XR_n + X^3R_n + \cdots + X^{2n-1}R_n$, so $\{X^{2i-1} + R_n\}_{1 \leq i \leq n}$ is a minimal generating set of R'_n/R_n as an R_n -module. Thus $l(R'_n/R_n) = n$. Since R_n has Krull dimension 1, $|O(R_n)| = |SStar(R_n)| = n+2$. Since $K, L[[X]] (= R_0), R_1, R_2, \dots, R_n$ are $n+2$ overrings of R_n , these are the only overrings of R_n . Therefore $O(R_n) = \{R_i\}_{1 \leq i \leq n} \cup \{K\}$ and $SStar(R_n) = \{*R_i\}_{1 \leq i \leq n} \cup \{e\}$. \square

Remark 5.3.8. *With a slight modification of the example given by Mimouni and Samman ([55, Example 3.3(2)]), given $(n, m) \in \mathbb{N}^2$ with $n \geq 2$ and $m \geq n+2$, we can construct an integral domain $S_{n,m}$ that satisfies the following conditions.*

1. $S_{n,m}$ is a nonintegrally closed non-Noetherian t^* -domain.
2. $|O(S_{n,m})| = |SStar(S_{n,m})| = m$.
3. $S_{n,m}$ has Krull dimension n .

Indeed, let L be a field and X_1, X_2, \dots, X_n be indeterminates over L . Set $L_n = L$, $L_i = L(X_{i+1}, \dots, X_n)$ so $L_{i-1} = L_i(X_i)$ for $1 \leq i \leq n$. Now set $K = L_0$, and $V_i = L_i[[X_i]] + M_{i-1}$ for $1 \leq i \leq n$ where M_i is the maximal ideal of V_i ($V_0 = L_0$ and $M_0 = 0$ by convention). Then V_i are valuation domains of Krull dimension i ([12, Theorems 2.1 and 3.1]), and $M_i = X_i V_i$, so $V_i = L_i + M_i$. Now set $R_{i,j} = L_{i+1}[[X_{i+1}^{2j}, X_{i+1}^{2j+1}]]$ and $T_{i,j} = R_{i,j} + M_i$ for each $j \in \mathbb{N}_0$. Then $\dim(T_{i,j}) = i+1$ and $O(T_{i,j}) = \{S + M_i \mid S \in O(R_{i,j})\} \cup O(V_i) = \{T_{i,r}\}_{0 \leq r \leq j} \cup O(V)$ (Lemma 5.3.7, [12, Theorems 2.1 and 3.1]). Moreover, $R_{i,j}$ is totally divisorial and conducive by Lemma 5.3.7, so $T_{i,j}$ is divisorial by [12, Corollary 4.4]. Since this is true for arbitrary i and j , we have that $T_{i,j}$ is totally divisorial. $T_{i,j}$ conducive since $T_{i,0}$ is a

valuation domain and $X_{i+1}^{2j}T_{i,0} = T_{i,j} : T_{i,0}$. Now $T'_{i,j} = R'_{i,j} + M_i = R_{i,0} + M_i$, so $l(T'_{i,j}/T_{i,j}) = j$. Hence $|O(T_{i,j})| = |SStar(T_{i,j})| = i + j + 2$ by Lemma 5.3.6. In fact, $O(T_{i,j}) = \{T_{i,j} \subsetneq T_{i,j-1} \subsetneq T_{i,j-2} \subsetneq \cdots \subsetneq T_{i,0} \subsetneq V_i \subsetneq V_{i-1} \subsetneq \cdots \subsetneq V_1 \subsetneq V_0\}$.

Now set $S_{n,m} = T_{n-1,m-n-1}$ and we have the desired domain.

Lastly, we will briefly investigate the property of numerical semigroup rings from the perspective of semistar operations. Precisely speaking, we establish the characterizations of numerical semigroup rings that are c^* -domains. Recall that a *numerical semigroup* is a nonempty set $H \subseteq \mathbb{N}$ that is closed under addition and contains the zero element such that $\mathbb{N} \setminus H$ is a finite set. It is known that a numerical semigroup can be generated by finitely many natural numbers $\alpha_1 < \cdots < \alpha_n$ such that $\gcd(\alpha_1, \dots, \alpha_n) = 1$. Conversely, the semigroup generated by natural numbers $\alpha_1, \dots, \alpha_n$ is a numerical semigroup if $\gcd(\alpha_1, \dots, \alpha_n) = 1$ ([28, Lemma 2.1]). Given a field L and a numerical semigroup $\alpha = \langle \alpha_1, \dots, \alpha_n \rangle$ we can consider the *numerical semigroup ring* $L[[X^{\alpha_1}, \dots, X^{\alpha_n}]]$ where X is an indeterminate of L . The following lemma shows that on a numerical semigroup ring, many classes of integral domains coincide.

Lemma 5.3.9. *Let L be a field, X an indeterminate, $\alpha = \{\alpha_i\}_{i=1}^n$ a subset of \mathbb{N} with $\alpha_i < \alpha_j$ for each $i < j$ and $\alpha_j \notin \sum_{1 \leq i < j} \alpha_i \mathbb{N}$. Define $R_\alpha = L[[X^{\alpha_1}, \dots, X^{\alpha_n}]]$ for each such α and let β the greatest common divisor of $\{\alpha_i\}_{i=1}^n$. Then the quotient field of R_α is that of $L[[X^\beta]]$, and the following are equivalent.*

1. R_α is a t^* -domain.
2. R_α is a c^* -domain.
3. $\alpha_1 \leq 2\beta$.
4. $R_\alpha = L[[X^{2\beta}, X^{(2n+1)\beta}]]$ for some $n \in \mathbb{N}_0$.
5. Each semistar operation on R_α is an extension to some overring of R_α .

6. R_α has property $*$.

7. R_α is stable.

8. R is totally divisorial.

Proof. The first assertion follows from the assumption that $\sum_{i=1}^n \alpha_i \mathbb{Z} = \beta \mathbb{Z}$. Now set $Y = X^\beta$. Note that Y is still an indeterminate over L .

1 \Rightarrow 2: Follows from Lemma 4.2.8.7.

2 \Rightarrow 3: Suppose that 2 is true. If $\alpha_1 > 2\beta$, then since β is a gcd of $\{\alpha_i\}_{i=1}^n$ we have $\alpha_1 \geq 3\beta$. Hence $L + Y^3 L[[Y]]$ is an overring of R_α that is a $c*$ -domain by Lemma 4.2.8.4. But this contradicts Remark 4.4.5.

3 \Rightarrow 4: Suppose that 3 is true. Then again since β is a gcd of $\{\alpha_i\}_{i=1}^n$, either $\alpha_1 = \beta$ or $\alpha_1 = 2\beta$. If $\alpha_1 = \beta$, then $R_\alpha = L[[Y]]$. If $\alpha_1 = 2\beta$, then $\alpha_2 = (2n + 1)\beta$ for some $n \in \mathbb{N}$ and $R_\alpha = L[[Y^2, Y^{2n+1}]]$.

4 \Rightarrow 1 and 5: Follows from Lemma 5.3.7.

5 \Rightarrow 6: Follows from Theorem 4.3.9.

6 \Rightarrow 3: If $\alpha_1 > 2\beta$, then $\alpha_1 \geq 3\beta$, $L + Y^3 L[[Y]]$ is an overring of R_α and R_α does not have property $*$ by Remarks 4.3.14 and 4.4.5.

5 \Rightarrow 8: Follows from Theorem 4.5.4.

8 \Rightarrow 7: By Theorem 4.5.5.

7 \Rightarrow 3: Suppose that R_α is stable. Then each overring of R_α is stable ([66, Theorem 5.1]). Therefore if $\alpha_1 > 2\beta$, then $L + Y^3 L[[Y]]$ is a stable overring of R_α . Now $L + Y^3 L[[Y]]$ has weak property $*$ by Remark 4.4.5. Hence $L + Y^3 L[[Y]]$ is a totally divisorial domain by Theorem 4.3.9, but $L + Y^3 L[[Y]]$ is not even divisorial (Theorem 4.4.4), so we have a contradiction. \square

5.4 Summarization of implications and equivalencies

The following lemma shows that for a completely integrally closed domain R is a c^* -domain if and only if $(SStar(R), \leq)$ is a totally ordered set.

Lemma 5.4.1. *Let R be a completely integrally closed domain. Then the following are equivalent.*

1. R is a valuation domain.
2. $|SStar(R)| \leq 3$.
3. R is a t^* -domain.
4. R is a c^* -domain.
5. R is a conducive domain.

Proof. $1 \Rightarrow 2$: Since a completely integrally closed valuation domain is one-dimensional ([29, Theorem 17.5]) the fact follows from Lemma 5.2.1.

$2 \Rightarrow 3$: Obvious.

$3 \Rightarrow 4$: By Lemma 4.2.8.7.

$4 \Rightarrow 5$: By Lemma 4.2.8.2.

$5 \Rightarrow 1$: By [10, Corollary 5]. □

On a stable domain several classes of domains turn out to be equivalent.

Corollary 5.4.2. *Let R be a stable domain. TFAE.*

1. R has property $*$.
2. R has weak property $*$.
3. R is a totally divisorial conducive domain.
4. R is a divisorial conducive domain.
5. R is a conducive domain that has an m -canonical ideal.

6. R is a t^* -domain.

7. R is a c^* -domain.

Proof. $1 \Leftrightarrow 2 \Leftrightarrow 3$: By Theorem 4.3.9.

$3 \Leftrightarrow 4 \Leftrightarrow 5$: By Theorem 4.5.5.

$3 \Rightarrow 6$: By Lemma 4.5.8.

$6 \Rightarrow 7$: By Lemma 4.2.8.

$7 \Rightarrow 3$: By Lemma 4.5.9.1. □

In addition, if R is integrally closed, then we could say more.

Corollary 5.4.3. *Let R be an integrally closed stable domain. TFAE.*

1. R has property $*$.

2. R has weak property $*$.

3. R is a totally divisorial conducive domain.

4. R is a divisorial conducive domain.

5. R is a t^* -domain.

6. R is a c^* -domain.

7. R is a strongly discrete valuation domain.

8. R is a valuation domain.

9. R is quasilocal.

10. Each semistar operation on R is of finite type.

Proof. Note that R is a Prüfer domain ([72, Proposition 2.1]).

$1 \Leftrightarrow 2 \Leftrightarrow 3 \Leftrightarrow 4 \Leftrightarrow 5 \Leftrightarrow 6$: By Corollary 5.4.2.

$3 \Rightarrow 7$: By Lemma 4.2.10.

$7 \Rightarrow 8 \Rightarrow 9$: Trivial.

$9 \Rightarrow 10$: If 9 holds, then R is a valuation domain, so it has property $*$ by Theorem 4.5.4

and must be totally divisorial by Theorem 4.3.9. Hence each semistar operation on R must be of finite type by Lemma 4.2.10.

10 \Rightarrow 7: By Lemma 4.2.10.

7 \Rightarrow 1: By Theorem 4.3.9. □

We also have the following diagram that summarizes the implications of a few of domains that have been discussed so far.

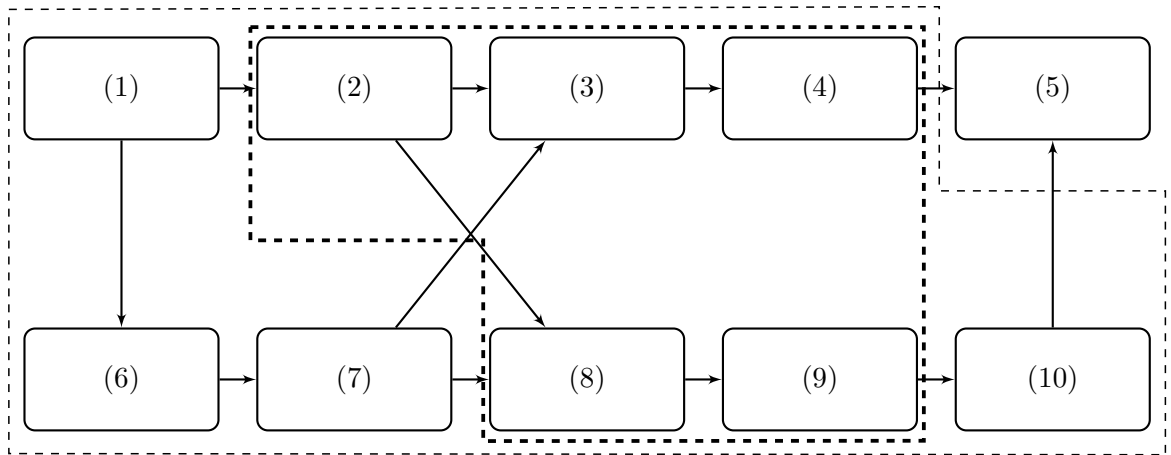

The corresponding classes of integral domains are as follows;

- (1): Strongly discrete valuation domains.
- (2): Totally divisorial conducive domains.
- (3): t^* -domains.
- (4): c^* -domains.
- (5): Conducive super- t -linkative domains.
- (6): Valuation domains.
- (7): PVDs that have at most two star operations.
- (8): Domains with Property $*$.
- (9): Domains with Weak Property $*$.
- (10): Conducive domains such that the set of prime ideals of each overring is totally

ordered under inclusion.

On stable domains (respectively, integrally closed stable domains), the domains inside the thickly (respectively, thinly) dashed line are equivalent by Corollary 5.4.2 (respectively, Corollary 5.4.3). The other implications are derived from the theorems and lemmas in the past chapters. For example,

(1) \Rightarrow (6): Follows from definition.

(1) \Rightarrow (2): Follows from Lemma 4.2.10.

(6) \Rightarrow (7): See remark 5.1.8.

(7) \Rightarrow (3) and (7) \Rightarrow (8): Follows from Lemma 5.1.7.

(2) \Rightarrow (3): Follows from Lemma 4.5.8.2(a).

(2) \Rightarrow (8): Follows from Theorem 4.3.9.

(3) \Rightarrow (4): Follows from Lemma 4.2.8.7.

(4) \Rightarrow (5): Follows from Lemma 4.2.8.5.

(8) \Rightarrow (9): Follows from definition.

(9) \Rightarrow (10): Lemma 4.3.6.3.

(10) \Rightarrow (5): Let R be a conducive domain such that set of prime ideals of each overring is totally ordered under inclusion. Then w operation and d operation coincide on each $T \in O(R)$. Hence R is super-t-linkative ([51, Proposition 2.7(b)]).

Remark 5.4.4. *The author was unable to find neither an example that shows (4) $\not\Rightarrow$ (3) nor a proof of (4) \Rightarrow (3), but all the other arrows in the above diagram are irreversible;*

(2) $\not\Rightarrow$ (1), (8) $\not\Rightarrow$ (7) and (3) $\not\Rightarrow$ (7): Let $R = L[[X^2, X^3]]$. Then R is totally divi-

serial conducive domain, so must be stable. But R is neither integrally closed nor a PVD, so this shows that the domains inside the thickly dashed line in general are not equivalent to the ones outside it.

(9) $\not\Rightarrow$ (8): See Remark 4.4.5.

(7) $\not\Rightarrow$ (6): Consider the domain described in Lemma 5.2.2(d). It is a PVD, but it cannot be a valuation domain since it is Noetherian and has 4 semistar operations (Lemma 5.2.1).

(8) $\not\Rightarrow$ (2), (6) $\not\Rightarrow$ (1) and (3) $\not\Rightarrow$ (2): Let R be any one-dimensional non-Noetherian valuation domain. Then R is a t^* -domain that has property $*$ that is not totally divisorial (Lemma 5.2.1).

(10) $\not\Rightarrow$ (9): Let L be the set of all algebraic numbers, X a transcendental number and $V = L[[X]]$, $M = XV$ and $R = \mathbb{Q} + M$. Then since $\mathbb{Q} \subsetneq L$ are fields, R is a PVD ([31, Example 2.1]), and thereby a conducive domain. Moreover, since V/M is an algebraic extension of R/M , each overring of R is a PVD ([20, Corollary 1.4 (c)]). Therefore the set of prime ideals of T is totally ordered for each overring T of R ([31, Corollary 1.3]). On the other hand, since $[V/M : R/M] = \infty$, R does not have weak property $*$ by Theorem 5.1.11.

(5) $\not\Rightarrow$ (4), and (5) $\not\Rightarrow$ (10): Given a transcendental number X , let $V = \mathbb{Q}[[X]]$, $M = XV$, $S = \mathbb{Z} - (2\mathbb{Z} \cup 3\mathbb{Z})$ and $D = Z_S$, $N_1 = 2D$, $N_2 = 3D$ and $R = D + M$. Then R

is a semilocal Prüfer domain with two maximal ideals $M_1 = N_1 + M$ and $M_2 = N_2 + M$ ([8, Theorem 2.1]) and must be conducive since V is a valuation overring and $X \in R : V$ (Theorem 4.2.6). We next claim that R is stable. Indeed, recall that an integral domain is integrally closed and stable if and only if it is a strongly discrete Prüfer domain that has finite character ([64, Theorem 4.6]). R has finite character since R is semilocal, and since M is the only nonzero nonmaximal prime ideal of R , it follows that R is strongly discrete. Hence R is stable. On the other hand, since R is not quasilocal, R is not a c^* -domain by Lemma 4.5.10.1. Moreover, since each Prüfer domain is t -linkative ([18, Corollary 2.7]), and every overring of a Prüfer domain is a Prüfer domain, R is super- t -linkative. Note that this example shows that domains described in (10) may not be equivalent to the domains inside the thinly dashed line even for integrally closed stable domains.

Chapter 6

Semistar operations on Multiplicative lattices

If you consider an ideal of a commutative ring as an object, rather than a set of elements of a ring, and endow a suitable operation on the collection of all the ideals, then it becomes a multiplicative lattice, another mathematical object. Commutative rings have two binary operations; addition and multiplication. Multiplicative lattices have only multiplication, but a good deal of statements in ring theory have a corresponding version in multiplicative lattice theory that can be rewritten in terms of lattice elements instead of ring elements. In other words, ideals are used as ‘building blocks’ in multiplicative ideal theory instead of the elements of a ring/ideal as in the classical commutative ring theory. Precisely speaking, elements of multiplicative lattices may correspond to ideals in commutative rings, and vice versa. So almost every results that has been already investigated in multiplicative ideal theory can be directly applied to multiplicative lattices. Therefore we can consider multiplicative lattices to be a more abstract and generalized version of commutative rings. At the same time other

algebraic objects like graded modules and commutative semigroups also have an inner structure that can be considered as multiplicative lattices ([63, Example 2.1]). Thus, if we prove a theorem about multiplicative lattices, then the corresponding theorems for commutative rings, graded modules and commutative semigroups are automatically proven.

6.1 Multiplicative lattices

A *monoid* is a set with an associative binary operation that has an identity. For any pair of elements I, J of a partially ordered set \mathcal{L} , we define the *meet* (respectively, *join*) of I and J to be the infimum (respectively, supremum) of I and J and denote by $I \wedge J$ (respectively, $I \vee J$). A *lattice* (\mathcal{L}, \leq) is a partially ordered set such that for every $I, J \in \mathcal{L}$, $I \wedge J \in \mathcal{L}$ and $I \vee J \in \mathcal{L}$. A lattice is called *complete* if every subset $\{I_\alpha\}_{\alpha \in A}$ of \mathcal{L} has an infimum and supremum (denoted $\bigwedge_{\alpha \in A} I_\alpha$ and $\bigvee_{\alpha \in A} I_\alpha$, respectively) in \mathcal{L} . A *complete lattice monoid* (*cl-monoid*) (\mathcal{L}, \leq) is a complete lattice that has a multiplicative monoid structure such that

- (1) if the smallest element of \mathcal{L} is 0, then $0I = 0$ for every $I \in \mathcal{L}$;
- (2) for any $I \in \mathcal{L}$ and family $(J_\alpha)_{\alpha \in A} \subset \mathcal{L}$, $I(\bigvee_{\alpha \in A} J_\alpha) = \bigvee_{\alpha \in A} IJ_\alpha$.

The multiplicative identity of \mathcal{L} is denoted by R . The set $\{X \in \mathcal{L} \mid X \leq R\}$ is denoted \mathcal{I} . If there is an element $R' \in \mathcal{L}$ such that $R'R' \leq R'$ and $R \leq R'$, then we call R' a *ring element* of \mathcal{L} . The *residuation* is defined as $I : J = \bigvee \{X \in \mathcal{L} \mid XJ \leq I\}$, for each $I, J \in \mathcal{L}$. A cl-monoid \mathcal{L} is said to be *integral* if R is the largest element in \mathcal{L} . We will use the notations $\mathcal{L}(R') = \{IR' \mid I \in \mathcal{L}\}$, $\mathcal{I}(R') = \{IR' \mid I \leq R\}$, and $\mathcal{L} = \mathcal{L}(R)$, $\mathcal{I} = \mathcal{I}(R)$.

Example 6.1.1. Let R be a ring. Then the set of ideals of R , ordered under the set inclusion, forms an integral cl-monoid by defining $I \vee J = I + J$, $I \wedge J = I \cap J$ for ideals I, J of R .

The notion of multiplicative lattice is to consider the ideal as an element instead of a subset of a ring that is closed under addition and multiplication by a ring element. For example, given a ring (that may not be commutative) R , an ideal P of R is a prime ideal if and only if for any pair of ideals I, J of R with $IJ \subset P$, either $I \subset P$ or $J \subset P$. Here, the point is that the definition of a prime ideal can be stated in terms of ideals without mentioning the elements of a ring. The goal of this thesis is to obtain the multiplicative lattice version of some of theorems in ring theory (especially multiplicative ideal theory). Of course, such transition is not always possible. In general, we abandon the algebraic structure of ideals to gain a greater generality of theorems, and because of that, we cannot hope to wield the powerful machinery developed in commutative ring theory (for instance, technics in homological algebra, the extension of a commutative ring to polynomial rings, etc). The notion of principal elements of a multiplicative lattice is one such example.

Definition 6.1.2. Let \mathcal{L} be a cl-monoid, and C, I, J, M, I_α be elements of \mathcal{L} . An element $M \in \mathcal{L}$ is *meet principal* (respectively, *join principal*) if $((I : M) \wedge J)M = I \wedge JM$ (respectively, $(IM \vee J) : M = I \vee (J : M)$) for all $I, J \in \mathcal{L}$. If M is both meet principal and join principal, it is a *principal* element of \mathcal{L} . Let I and $\{I_\alpha\}_{\alpha \in A}$ be elements of a cl-monoid \mathcal{L} . We say that an element $I \in \mathcal{L}$ is *generated* by $\{I_\alpha\}_{\alpha \in A}$ if $I = \bigvee_{\alpha \in A} I_\alpha$. I is *finitely generated* if it is generated by finitely many principal elements.

\mathcal{L} is *principally generated* if each element of \mathcal{L} is generated by principal elements. A *compact element* is an element $C \in \mathcal{L}$ such that whenever $C \leq \bigvee \{I_\alpha \mid \alpha \in A\}$, there

exists a finite subset A' of A such that $C \leq \bigvee \{I_\alpha \mid \alpha \in A'\}$. $I \in \mathcal{L}$ is called an *invertible element* if there exists some element $J \in \mathcal{L}$ such that $IJ = R$.

Definition 6.1.3. Let \mathcal{L} be a cl-monoid. \mathcal{L} is a *quotient field lattice* (abbreviated q.f. lattice) if the following hold:

1. $AK = K$ for every nonzero $A \in \mathcal{L}$, where $K = \bigvee \mathcal{L}$ is the largest element of \mathcal{L} .
2. \mathcal{L} is principally generated.
3. There exists a compact, invertible element in \mathcal{L} .
4. For every $A \in \mathcal{L} \setminus \{0\}$, $A \wedge R \neq 0$.

The definition of principal elements was first introduced by Dilworth [16]. One can easily check that if \mathcal{L} is multiplicative lattice from Example 1.1, then every principal ideal of R is a principal element of \mathcal{L} . Actually, if \mathcal{L} is the lattice of ideals of an integral domain R , with lattice structure defined as in Example 6.1.1, then an element I of \mathcal{L} is a principal element of \mathcal{L} if and only if I is a finitely generated ideal of R such that IR_M is a principal ideal of R_M for each maximal ideal M of R ([6]); in particular, if R is an integral domain, then I is a principal element of the lattice of ideals of R if and only if I is an invertible ideal of R . Therefore, we can easily see that the definition of 'principality' in multiplicative lattice is weaker than that of commutative rings. However, using it, we can define other ring-theoretic properties on multiplicative lattices localization.

Definition 6.1.4. We say a subset \mathcal{S} of \mathcal{I} is *multiplicatively closed set for R* if \mathcal{S} is a multiplicatively closed set of nonzero principal nonzero-divisors in \mathcal{I} . Then for each element $A \in \mathcal{L}$, we define the localization of A by $A_{\mathcal{S}} = \bigvee \{(A : s) \mid s \in \mathcal{S}\}$.

Definition 6.1.5. An element $P < R$ of \mathcal{L} is called a *prime element* if $IJ \leq P$ implies either $I \leq P$ or $J \leq P$ for every $I, J \leq R$.

Note that for each prime element P , $\mathcal{S}(P) = \{s \in \mathcal{L} \mid s \text{ is principal, } s \not\leq P\}$ is a multiplicatively closed set. We denote $A_{\mathcal{S}(P)}$ by A_P . Following are some basic properties of localizations, inherited from classical ring theory.

Theorem 6.1.6. [15, Section 2] *Let \mathcal{L} be a q.f. lattice and \mathcal{S} a multiplicatively closed set of \mathcal{I} . Then*

1. $R_{\mathcal{S}}$ is a ring element.
2. If $A \in \mathcal{L}$, then $(A_{\mathcal{S}})_{\mathcal{S}} = A_{\mathcal{S}}$.
3. If $A, B \in \mathcal{L}$, then $(A \wedge B)_{\mathcal{S}} = A_{\mathcal{S}} \wedge B_{\mathcal{S}}$, $(A \vee B)_{\mathcal{S}} = A_{\mathcal{S}} \vee B_{\mathcal{S}}$, $(AB)_{\mathcal{S}} = A_{\mathcal{S}}B_{\mathcal{S}}$. If B is finitely generated, then $(A : B)_{\mathcal{S}} = A_{\mathcal{S}} : B_{\mathcal{S}}$.

We have to define b -dependent elements in order to define integrally closed lattices.

Definition 6.1.7. Let \mathcal{L} be a q. f. lattice. An element $A \in \mathcal{L}$ is *b -dependent on R* if and only if there exists a finite join B of \mathcal{L} -principal elements and a positive integer n such that $(R \vee A)^n \leq B$ and $AB \leq B$. The element of \mathcal{L} , $R_b = \vee\{B_i \mid B_i \text{ is } b\text{-dependent on } R\}$ is called the *b -closure of R in \mathcal{L}* . Brithinee [14, Definition 3.38] defined an element $A \in \mathcal{L}$ to be *integral over R* if it is a join of elements in \mathcal{L} that are b -dependent on R . Hence R_b is also called the *integral closure of R in \mathcal{L}* . \mathcal{I} is *integrally closed* if $R = R_b$.

Definition 6.1.8. Let \mathcal{L} be a q. f. lattice. An element $A \in \mathcal{L}$ is *fractionary* if there is a nonzero $D \in \mathcal{I}$ such that $DA \in \mathcal{I}$.

Theorem 6.1.9. *\mathcal{I} is integrally closed if and only if $I : I = R$ for any finitely generated fractionary element I of \mathcal{L} .*

Proof. \Rightarrow : Suppose that \mathcal{I} is integrally closed, and let $I = a_1 \vee \cdots \vee a_n$ for some principal elements $a_i \in \mathcal{L}$. Let $X \leq I : I$ be a principal element. Then $X \leq Ia_1^{-1}$. Now

$R \vee X \leq Ia_1^{-1}$ and $XIa_1^{-1} \leq Ia_i^{-1}$, so X is integral over R and $X \leq R$, which yields $I : I \leq R$. The opposite inequality is trivial, and we obtain $I : I = R$.

\Leftarrow : If $I : I = R$ for any finitely generated fractionary element I of \mathcal{L} , then every b-dependent element is an element of \mathcal{I} by definition and $R = R_b$ follows. \square

6.2 Semistar operations on q.f. lattices

Now we will introduce the lattice version of a semistar operation. Before presenting the actual definition, We will introduce some of the notations; given a q.f. lattice \mathcal{L} and a ring element R' of \mathcal{L} , $\mathcal{L}(R)'$ will denote the set of all nonzero elements of $\mathcal{L}(R')$, $f(\mathcal{L}(R'))$ the set of finitely generated elements of $\mathcal{L}(R')$, $F(\mathcal{L}(R'))$ the set of fractionary elements in $\mathcal{L}(R')$. Most of the time we will use the notations \mathcal{L}' , $f(\mathcal{L})$ and $F(\mathcal{L})$, where $\mathcal{L} = \mathcal{L}(R)$ as mentioned in the preceding section.

Definition 6.2.1. Let \mathcal{L} be a q. f. lattice and let \mathcal{F} denote the set of nonzero elements of \mathcal{L} . A map $*$: $\mathcal{L}' \rightarrow \mathcal{L}'$ is a *semistar operation* if for all $A, B \in \mathcal{L}'$ and all principal elements $a \in \mathcal{L}'$, the following hold:

1. $(aA)^* = aA^*$,
2. $A \leq A^*$.
3. $A \leq B \Rightarrow A^* \leq B^*$.
4. $(A^*)^* = A^*$.

If $R^* = R$, we will call $*$ a *(semi)star operation*.

Example 6.2.2. *v-operation* is defined as $I_v = R : (R : I)$ for each $I \in \mathcal{L}'$. *w-operation* is defined as $I_w = \bigvee \{I : J \mid J_v = R, J \text{ is a finitely generated element of } \mathcal{I}\}$ for each $I \in \mathcal{L}'$. These two operations are *(semi)star operations* on \mathcal{L}' (cf. [44, Definition 2.2.1, Proposition 4.1.6])

Semistar operations of finite type and stable semistar operations are defined similarly.

Definition 6.2.3. Let \mathcal{L} be a q. f. lattice and $*$: $\mathcal{L}' \rightarrow \mathcal{L}'$ be a semistar operation on \mathcal{L} . We say that $*$ is of *finite type* if for every $A \in \mathcal{L}'$, $A^* = \bigvee \{B^* \mid B \in \mathcal{L} \text{ is finitely generated and } B \leq A\}$. On the other hand, $*$ is said to be *stable* if $(A \wedge B)^* = A^* \wedge B^*$ for each $A, B \in \mathcal{L}'$.

Theorem 6.2.4. (cf. [21, Theorem 1.2]) Let \mathcal{L} be a q.f.lattice and $*$ be a semistar operation on \mathcal{L} . Then for all $I, J \in \mathcal{L}'$ and nonempty family of $\{I_\alpha\}_{\alpha \in A} \subset \mathcal{L}'$,

1. $(\bigvee_{\alpha \in A} I_\alpha)^* = (\bigvee_{\alpha \in A} I_\alpha^*)^*$;
2. $\bigwedge_{\alpha \in A} I_\alpha^* = (\bigwedge_{\alpha \in A} I_\alpha^*)^*$, if $\bigwedge_{\alpha \in A} I_\alpha^* \neq (0)$;
3. $(IJ)^* = (I^*J)^* = (IJ^*)^* = (I^*J^*)^*$.
4. $(I : J)^* \leq I^* : J^* = I^* : J$.
5. If R' is a ring element of \mathcal{L} , then R'^* is a ring element. In particular, R^* is a ring element.
6. Let $\mathcal{R} = \{R_\alpha \mid \alpha \in A\}$ be a family of ring elements of R . Then $I \mapsto I^*$ where $I^* = \bigwedge_{\alpha \in A} IR_\alpha$ is a semistar operation on R . Moreover, $I^*R_\alpha = IR_\alpha$ for each $\alpha \in A$.

Proof. 1. Since $I_\alpha \leq I_\alpha^*$ for each α , $(\bigvee_{\alpha \in A} I_\alpha) \leq \bigvee_{\alpha \in A} I_\alpha^*$ and $(\bigvee_{i \in I} I_\alpha)^* \leq (\bigvee_{\alpha \in A} I_\alpha^*)^*$.

On the other hand, since $I_\beta \leq \bigvee_{\alpha \in A} I_\alpha$ for each $\beta \in A$, we have $I_\beta^* \leq (\bigvee_{\alpha \in A} I_\alpha)^*$ for each $\beta \in A$ and $\bigvee_{\alpha \in A} I_\alpha^* \leq (\bigvee_{\alpha \in A} I_\alpha)^*$. Thus $(\bigvee_{\alpha \in A} I_\alpha^*)^* \leq ((\bigvee_{\alpha \in A} I_\alpha)^*)^* = (\bigvee_{\alpha \in A} I_\alpha)^*$.

2. $\bigwedge_{\alpha \in A} I_\alpha^* \leq (\bigwedge_{\alpha \in A} I_\alpha^*)^*$ follows immediately from the definition of semistar operations. Conversely, since $\bigwedge_{\alpha \in A} I_\alpha^* \leq I_\beta^*$ for all $\beta \in A$, we have $(\bigwedge_{\alpha \in A} I_\alpha^*)^* \leq (I_\beta^*)^* = I_\beta^*$ for all $\beta \in A$. Therefore $(\bigwedge_{\alpha \in A} I_\alpha^*)^* \leq \bigwedge_{\alpha \in A} I_\alpha^*$.

3. It suffices to show the first equality. Since $J \leq J^*$, $(IJ)^* \leq (IJ^*)^*$ is obvious. To show the other direction, We will prove $IJ^* \leq (IJ)^*$. Choose a principal element X of

\mathcal{L} such that $X \leq ((IJ)^* : J)$. Then $XJ \leq (IJ)^*$, so $XJ^* = (XJ)^* \leq ((IJ)^*)^* = (IJ)^*$, and $X \leq ((IJ)^* : J^*)$. It follows that $I \leq (IJ : J) \leq ((IJ)^* : J) \leq ((IJ)^* : J^*)$, and thereby $IJ^* \leq (IJ)^*$.

4. The first inequality follows since $(I : J)^*J^* \leq ((I : J)^*J^*)^* = ((I : J)J)^* \leq I^*$ by part 3. For the equality, consider a principal element $X \leq I^* : J$. Then $XJ \leq I^*$ so $XJ^* = (XJ)^* \leq (I^*)^* = I^*$, and $X \leq I^* : J^*$. Thus $I^* : J \leq I^* : J^*$. Conversely, since $J \leq J^*$, we have $I^* : J^* \leq I^* : J$. Thus the equality follows.

5. Let R' be a ring element of \mathcal{L} . Then clearly $R \leq R'^*$, and by part 3, $(R'^*)^2 = R'^*R'^* \leq (R'^*R'^*)^* = (R'R')^* \leq R'^*$. So R'^* is a ring element.

6. The first condition of Definition 6.2.1 follows since for any $I \in \mathcal{L}$ and a nonzero principal element $X \in \mathcal{L}$, we have $(XI)^* = \bigwedge_{\alpha \in A} XIR_\alpha = X(\bigwedge_{\alpha \in A} IR_\alpha) = XI^*$. The second condition holds trivially. For the last one, it suffices to show that $(I^*)^* \leq I^*$. Note that for any $\gamma \in A$, $(I^*)^* = (\bigwedge_{\alpha \in A} IR_\alpha)^* = \bigwedge_{\beta \in A} (\bigwedge_{\alpha \in A} IR_\alpha)R_\beta \leq (\bigwedge_{\alpha \in A} IR_\alpha)R_\gamma \leq IR_\gamma R_\gamma \leq IR_\gamma$, so $(I^*)^* \leq \bigwedge_{\gamma \in A} IR_\gamma = I^*$. The last part of this theorem also follows similarly; $IR_\alpha \leq I^*R_\alpha \leq (\bigwedge_{\beta} IR_\beta)R_\alpha \leq IR_\alpha R_\alpha \leq IR_\alpha$ for each $\alpha \in A$. \square

Before proving an analogous version of the famous theorem by Cohen, we need more definitions. An element $I \in \mathcal{L}$ is said to be a *quasi-* element* if $I^* \wedge R = I$. Note that each *-element of \mathcal{I} is a quasi-* element, and if $*$ is a (semi)star operation, then the notion of *-elements and quasi-* elements coincide. We say that a q.f. lattice \mathcal{L} is **-Noetherian* if it has the ascending chain condition on quasi-* elements; i.e., if $\{I_n\}_{n \in \mathbb{N}}$ is a collection of quasi-* elements on \mathcal{L} such that $I_1 \leq I_2 \leq \dots$, then there exists $k \in \mathbb{N}$ such that $I_n = I_k$ for all $n \geq k$.

Theorem 6.2.5. *For a q.f. lattice \mathcal{L} and a semistar operation $*$ of finite type on \mathcal{L} , TFAE.*

1. \mathcal{L} is $*$ -Noetherian.
2. Each $*$ -element of \mathcal{L} is of finite type.
3. Each prime $*$ -element of \mathcal{L} is of finite type.

Proof. 3 \Rightarrow 2: (cf.[41, Theorem 7]) Assume 3 holds. If $\mathcal{S} = \{I \in \mathcal{I} \mid I \text{ is a non-finite type } * \text{-element}\} \neq \emptyset$, then by Zorn's lemma \mathcal{S} has a maximal element, say P . Suppose that P is not a prime element. Then there exists principal elements $A, B \in \mathcal{I}$ with $A \not\leq P, B \not\leq P$ and $AB \leq P$. Then $P < (P : A)$ and $(P : A)$ is a $*$ -element, so $(P : A) = (\bigvee_{i \in I} C_i)^*$ for some finitely many principal elements $C_i \leq (P : A)$ by maximality of P . Thus we have

$$P = A(P : A) = A(\bigvee_{i \in I} C_i)^* \leq (A \bigvee_{i \in I} C_i)^* = (A(P : A))^* = P^* = P,$$

so $P = (A \bigvee_{i \in I} C_i)^* = (\bigvee_{i \in I} AC_i)^*$, and P is of finite type, which is a contradiction.

Thus P must be a prime $*$ -element, but that contradicts the assumption.

2 \Rightarrow 3: Trivial.

1 \Leftrightarrow 2: [7, Lemma 3.3]) Let \mathcal{L} be a $*$ -Noetherian lattice. $I \leq \mathcal{I}'$, and choose a principal element $A_1 \leq I$. If $I^* \neq A_1^*$, then clearly $I^* \not\leq A_1^* \wedge R$ and there exists a principal element $A_2 \leq I^*$ and $A_2 \not\leq A_1^* \wedge R$. Iterating this process, we get an ascending chain of element of \mathcal{I} $\{I_n = (A_1 \vee \cdots \vee A_n)^* \wedge R\}_{n \in \mathbb{N}}$. Then by assumption there exists $k \in \mathbb{N}$ so $I_n = I_k$ for all $n \geq k$. Therefore $I^* = (A_1 \vee \cdots \vee A_k)^*$.

Conversely, if 2 is true, then for an ascending chain $\{I_n\}_{n \in \mathbb{N}}$ of quasi- $*$ -elements of \mathcal{L}' , set $I = \bigvee_{n \in \mathbb{N}} I_n$. Now since $*$ is of finite type, we must have a finitely generated $J \leq I$ such that $I^* = J^*$ by assumption. Thus there exists $k \in \mathbb{N}$ such that $J \leq I_k$. Thus $I^* = J^* = I_k^*$, and $I_k = I_k^* \wedge R = I^* \wedge R = I$, so the chain is stationary. \square

6.3 Localizing systems on q.f. lattices

We will also define the localizing system of q.f. lattices as a generalization of that of integral domains. The proofs of almost every theorem, proposition and lemma presented in the remainder of this section are just a simple, almost word-by-word transition of that of [21], and included only for the sake of the completeness.

Definition 6.3.1. Let \mathcal{L} be a q. f. lattice. We say that \mathcal{F} is a *localizing system of R* if \mathcal{F} is a collection of elements of $\mathcal{I}(R)$ such that

1. If $I \in \mathcal{F}$ and J is an element of $\mathcal{I}(R)$ such that $J \geq I$, then $J \in \mathcal{F}$;
2. If $I \in \mathcal{F}$ and J is an element of $\mathcal{I}(R)$ such that $(J :_{\mathcal{I}(R)} X) \in \mathcal{F}$ for each principal element $X \leq I$, then $J \in \mathcal{F}$.

We will assume that a localizing system \mathcal{F} is nontrivial, i.e., \mathcal{F} is nonempty and $(0) \notin \mathcal{F}$. The following are basic properties of a localizing system.

Proposition 6.3.2. *1.If $I, J \in \mathcal{F}$, then $IJ \in \mathcal{F}$ and $I \wedge J \in \mathcal{F}$.*

2. $\bigvee\{X \mid X \text{ is } \mathcal{L}\text{-principal and } (J :_{\mathcal{I}(R)} X) \in \mathcal{F}\} = \bigvee\{(J : I) \mid I \in \mathcal{F}\}$ for each $J \in \mathcal{L}$.
3. (cf. [21, Proposition 2.4]) For each $J \in \mathcal{L}$, the map $J \mapsto J_{\mathcal{F}} = \bigvee\{(J : I) \mid I \in \mathcal{F}\}$ for each $J \in \mathcal{L}$ is a stable semistar operation on R . We call this operation the semistar operation associated with \mathcal{F} and denote this semistar operation by $*_{\mathcal{F}}$.

Proof. 1. For any principal $X \leq I$ we have $J \leq (IJ :_{\mathcal{I}(R)} I) = (IJ :_{\mathcal{I}(R)} X)$, so by 1 of Definition 6.3.1, $(IJ :_{\mathcal{I}(R)} X) \in \mathcal{F}$. Now by 2 of Definition 6.3.1, $IJ \in \mathcal{F}$. Since $I \leq R$ and $J \leq R$, we have $IJ \leq I$ and $IJ \leq J$. Hence $IJ \leq I \wedge J$, and $I \wedge J \in \mathcal{F}$ by 1 of Definition 6.3.1.

2. Choose an \mathcal{L} -principal X such that $(J :_{\mathcal{I}(R)} X) \in \mathcal{F}$. Then $X(J :_{\mathcal{I}(R)} X) \leq X(J : X) \leq J$, so $X \leq (J : (J :_{\mathcal{I}(R)} X)) \leq \bigvee\{(J : I) \mid I \in \mathcal{F}\}$ for each $J \in \mathcal{L}$.

Therefore $\bigvee\{X \mid X \text{ is } \mathcal{L}\text{-principal and } (J :_{\mathcal{I}(R)} X) \in \mathcal{F}\} \leq \bigvee\{(J : I) \mid I \in \mathcal{F}\}$ for each $J \in \mathcal{L}$. Conversely, if a principal element X satisfies $X \leq (J : I)$ for some $I \in \mathcal{F}$, then $I \leq (J :_{\mathcal{I}(R)} X)$, so by 1 of Definition 6.3.1, $(J :_{\mathcal{I}(R)} X) \in \mathcal{F}$. So $\bigvee\{(J : I) \mid I \in \mathcal{F}\}$ for each $J \in \mathcal{L}$ and $\bigvee\{X \mid X \text{ is } \mathcal{L}\text{-principal and } (J :_{\mathcal{I}(R)} X) \in \mathcal{F}\} \leq \bigvee\{X \mid X \text{ is } \mathcal{L}\text{-principal and } (J :_{\mathcal{I}(R)} X) \in \mathcal{F}\}$.

3. Let X be a principal element. Then $(XI : J) = (I : X^{-1}J) = ((I : J) : X^{-1}) = (I : J)(X^{-1})^{-1} = X(I : J)$ for any $I, J \in \mathcal{L}$ ([15, lemma 1.19.2]), so $(XI)_{\mathcal{F}} = \bigvee\{(XI : J) \mid J \in \mathcal{F}\} = \bigvee\{X(I : J) \mid J \in \mathcal{F}\} = X(\bigvee\{(I : J) \mid J \in \mathcal{F}\}) = XI_{\mathcal{F}}$, so the first condition of Definition 6.2.1 is proved.

Since $R \in \mathcal{F}$, $I \leq I_{\mathcal{F}}$ for any $I \in \mathcal{L}$. Clearly $I \leq J$ implies $I_{\mathcal{F}} \leq J_{\mathcal{F}}$. This gives us the second condition of Definition 6.2.1. To show the last condition of being a semistar operation, it is enough to prove that $(J_{\mathcal{F}} : I) \leq J_{\mathcal{F}}$ for all $I \in \mathcal{F}$. Fix $I \in \mathcal{F}$. For a principal element $X \leq (J_{\mathcal{F}} : I)$, we have $XI \leq J_{\mathcal{F}}$ and $XY \leq J_{\mathcal{F}}$, for every principal element $Y \leq I$. Then XY is principal ([15, lemma1.10.3]) and $XY \leq \bigvee\{(J : I') \mid I' \in \mathcal{F}\}$. Since XY is compact ([15, lemma1.28.2 and 1.28.5]), $XY \leq \bigvee_{i=1}^n (J : I_i) \leq (J : I_1 \cdots I_n)$ for some $I_i \in \mathcal{F}$. Thus $XI \leq (J : I_1 \cdots I_n)$ and $X \leq (J : I_1 \cdots I_n I) \leq J_{\mathcal{F}}$. The last inequality follows from part 1 of this proposition since $I_i, I \in \mathcal{F}$. Thus we have shown that $(J_{\mathcal{F}} : I) \leq J_{\mathcal{F}}$.

Therefore the given operation is a semistar operation. It is a stable semistar operation since for any $X \in \mathcal{L}$, $(I \wedge J : X) = (I : X) \wedge (J : X)$. \square

For a multiplicatively closed subset \mathcal{S} of R , $\mathcal{F} = \{I \leq R \mid X \in \mathcal{S} \text{ for some principal } X \leq I\}$ is a localizing system of R . In particular, $\mathcal{F}(P) = \{I \mid I \leq R, I \not\leq P\}$ is a localizing system. If $\{\mathcal{F}_{\alpha}\}_{\alpha \in A}$ is a family of localizing systems, then $\mathcal{F} = \bigcap_{\alpha \in A} \mathcal{F}_{\alpha}$

is a localizing system. Therefore, if Δ is a nonempty subset of $\text{Spec } R$, then $\mathcal{F}(\Delta) = \bigcap_{P \in \Delta} \mathcal{F}(P)$ is a localizing system.

Theorem 6.3.3. (cf. [21, Proposition 2.8]) *If $*$ is a semistar operation on then $\mathcal{F}^* = \{I \mid I \text{ ideal of } R \text{ with } I^* \wedge R = R\}$ is a localizing system on R .*

This localizing system is called *the localizing system associated to $*$* .

Proof. Clearly $I \in \mathcal{F}^*$ and $J \geq I$ implies that $J \in \mathcal{F}^*$. Let $(J :_{\mathcal{I}(R)} X)^* \wedge R = R$ for each principal $X \leq I$. Now $X^*(J :_{\mathcal{I}(R)} X)^* \leq (X^*(J :_{\mathcal{I}(R)} X)^*)^* = (X(J :_{\mathcal{I}(R)} X))^* \leq (J \wedge R)^* \leq J^* \wedge R^*$ and $(J :_{\mathcal{I}(R)} X)^* \leq (J^* :_{\mathcal{I}(R^*)} X^*)$. Moreover, $(J^* :_{\mathcal{I}(R)} X) = (J^* :_{\mathcal{I}(R^*)} X^*)$. Indeed, $(J^* :_{\mathcal{I}(R^*)} X^*) \leq (J^* :_{\mathcal{I}(R)} X)$ since $X \leq X^*$. On the other hand, for any principal $Y \leq (J^* : X)$ we have $YX \leq J^*$. Hence $YX^* = (YX)^* \leq (J^*)^* = J^*$ and $Y \leq (J^* : X^*)$.

Thus $(J^* :_{\mathcal{I}(R)} X) = (J^* :_{\mathcal{I}(R^*)} X^*)$. Now we have

$$R = (J :_{\mathcal{I}(R)} X)^* \wedge R = (J :_{\mathcal{I}(R)} X)^* \wedge R \leq (J^* :_{\mathcal{I}(R^*)} X^*) \wedge R = (J^* :_{\mathcal{I}(R)} X) \wedge R, \text{ so } X \leq J^*.$$

This shows that $I \leq J^*$ and $J^* \in \mathcal{F}^*$. Hence $J^* \wedge R = (J^*)^* \wedge R = R$, and $J \in \mathcal{F}^*$. Therefore \mathcal{F}^* is a localizing system. \square

Nextly we introduce the lattice version of localizing systems of finite type. Again, many of the properties carry over smoothly.

Definition 6.3.4. *A localizing system of finite type* is a localizing system \mathcal{F} such that for each $I \in \mathcal{F}$ there exists a finitely generated $J \in \mathcal{F}$ with $J \leq I$.

Definition 6.3.5. Let \mathcal{L} be a q.f. lattice and $* : \mathcal{L}' \rightarrow \mathcal{L}'$ be a semistar operation on \mathcal{L} . We say that $I \in \mathcal{L}$ is of finite type if $I = J^*$ for some finitely generated element $J \leq I$.

Lemma 6.3.6. (cf. [21, Lemma 3.1]) Given a localizing system \mathcal{F} of a q.f. lattice \mathcal{L} , $\mathcal{F}_f = \{I \in \mathcal{F} \mid I \geq J \text{ for some nonzero finitely generated } J \in \mathcal{F}\}$ is a localizing system of finite type of \mathcal{L} .

Proof. \mathcal{F}_f obviously satisfies the first condition of being a localizing system, so we can focus on the second condition. Let $I \in \mathcal{F}_f$ and J is an element of $\mathcal{I}(R)$ such that $(J :_{\mathcal{I}(R)} x) \in \mathcal{F}_f$ for each principal element $x \leq I$. We may assume that I is finitely generated. Indeed, since $I \in \mathcal{F}_f$, there exists a finitely generated element I' of \mathcal{F} with $I' \leq I$, so if I is not finitely generated, we can replace I with I' . Let $I = x_1 \vee \cdots \vee x_n$ with x_i principal. Then since $x_i \leq I$, there exists a finitely generated $H_i \in \mathcal{F}$ such that $H_i \leq (J :_{\mathcal{I}(R)} x_i)$. If $H = H_1 \cdots H_n$, then H is a finitely generated element of \mathcal{F} , so $H \in \mathcal{F}_f$ and $HI \in \mathcal{F}_f$. Also, $Hx_i \leq J$ for each i and $HI = H(x_1 \vee \cdots \vee x_n) = \bigvee (Hx_i) \leq J$, which implies $J \in \mathcal{F}_f$. \square

Proposition 6.3.7. (cf. [21, Proposition 3.2]) Let \mathcal{L} be a q.f. lattice and $* : \mathcal{L}' \rightarrow \mathcal{L}'$ be a semistar operation and \mathcal{F} a localizing system on \mathcal{L} .

1. If \mathcal{F} is of finite type, then $*_{\mathcal{F}}$ is of finite type.
2. If $*$ is of finite type, then \mathcal{F}^* is of finite type.

Proof. 1. We have to show that for nonzero $I \in \mathcal{L}$, $I^{\mathcal{F}^*} = \bigvee J^{\mathcal{F}^*}$ where the join is taken over every finitely generated $J \leq I$. Choose a principal element X such that $XJ \leq I$ for some $J \in \mathcal{F}^*$. Then since \mathcal{F} is of finite type there exists finitely generated $J' \leq J$ such that $J \in \mathcal{F}^*$. Then $X \leq (XJ' : J') \leq (XJ')^{\mathcal{F}^*}$, and $XJ' \leq I$ is finitely generated.

2. Let $I \in \mathcal{F}^*$. Then $R^* = I^* = \bigvee \{J^* \mid J \leq I, J \text{ is finitely generated}\}$ and R is compact, so $R^* = \bigvee_{i=1}^n J_i^*$ for some finitely generated $J_i \leq I$. Let $J = \bigvee_{i=1}^n J_i$. Then J is finitely generated, $J^* = R^*$ and $J \leq I$. \square

Spectral semistar operations will be the next topic we will be concerned.

Lemma 6.3.8. (cf. [21, Lemma 4.1]) Let \mathcal{L} be a q.f. lattice and $\text{Spec}(\mathcal{I})$ the set of prime elements of \mathcal{I} . Given a nonempty set $\Delta \subset \text{Spec}(\mathcal{I})$, define $I^{*\Delta} = \bigwedge \{IR_P \mid P \in \Delta\}$ for each $I \in \mathcal{L}'$.

(1) If $\Delta \subset \text{Spec}(\mathcal{I})$ is nonempty, then the mapping $I \mapsto I^{*\Delta}$, for each $I \in \mathcal{L}$ defines a semistar operation.

(2) For each $I \in \mathcal{L}'$ and for each $P \in \Delta$, $IR_P = I^{*\Delta}R_P$.

(3) $*^\Delta$ is a stable semistar operation on \mathcal{L} .

(4) For each $P \in \Delta$, $P^{*\Delta} \wedge R = P$.

(5) For each $I \leq R$ such that $I^{*\Delta} \wedge R \neq R$, there exists $P \in \Delta$ such that $I \leq P$.

Proof. (1) and (2) follows from 6 of Theorem 6.2.4.

(3) Note that $IR_P \wedge JR_P = (I \wedge J)R_P$ [15, Proposition 2.12]. Thus $I^{*\Delta} \wedge J^{*\Delta} = (\bigwedge_{P \in \Delta} IR_P) \wedge (\bigwedge_{P \in \Delta} JR_P) = \bigwedge_{P \in \Delta} (IR_P \wedge JR_P) = \bigwedge_{P \in \Delta} (I \wedge J)R_P = (I \wedge J)^{*\Delta}$.

(4) By [15, Corollary 3.12] and [15, Proposition 3.15], we have

$$P^{*\Delta} \wedge R = \bigwedge_{Q \in \Delta} PR_Q = \bigwedge_{Q \in \Delta, Q \geq P} PR_Q \leq \bigwedge_{Q \in \Delta, Q \geq P} Q = P.$$

(5) If $I \leq R$ such that $I^{*\Delta} \wedge R \neq R$, then $I^{*\Delta} < R$ and $I^{*\Delta}R_P \neq R_P$ for some $P \in \Delta$.

Hence by [15, Corollary 3.12], $I^{*\Delta}R_P \leq PR_P$ and thus $I \leq I^{*\Delta}R_P \wedge R \leq PR_P \wedge R = P$. □

Definition 6.3.9. Let $*$ be a semistar operation on \mathcal{L} . If there exists a nonempty set $\Delta \subset \text{Spec}(\mathcal{I})$ such that $* = *^\Delta$, then say that $*$ is a *spectral semistar operation associated to Δ* .

Lemma 6.3.10. (cf. [21, Lemma 4.20]) Let $*$ be a semistar operation of finite type on R , with $R^* \neq K$. where $K = \bigvee \mathcal{L}$. Let $S = \{I \mid 0 \neq I \leq R, I^* \wedge R \neq R\}$. Then for every $I \in S$, I is contained in a maximal element of S . Furthermore, every maximal element of S is a prime element of \mathcal{L} .

Proof. Let $S' = \{J \mid J \in S, J \geq I\}$. We're first show that S' has a maximal element using Zorn's lemma, and that each maximal element of S' is prime.

1. S' has a maximal element.

For choose a nonzero element $X \leq R$ that is not $\mathcal{L}(R^*)$ -principal (such X exists since otherwise every element of \mathcal{L} , in particular K , is $\mathcal{L}(R^*)$ -principal, which implies K is $\mathcal{L}(R^*)$ -invertible [15, Corollary 1.28] and $R^* = K$, which contradicts the assumption) and $X^* \wedge R \in S$, so S' is nonempty. S' is nonempty since $I \in S'$. Now choose an ascending chain $\{I_\alpha \mid \alpha \in A\}$ in S' . Then obviously $\bigvee_\alpha I_\alpha^* \leq (\bigvee_\alpha I_\alpha)^*$. To show the converse inequality, choose a principal $X \leq (\bigvee_\alpha I_\alpha)^*$. We have to show that $X \leq \bigvee_\alpha I_\alpha^*$. Since $*$ is of finite type, $(\bigvee_\alpha I_\alpha)^* = \bigvee\{J^* \mid J \leq \bigvee_\alpha I_\alpha, J \text{ is finitely generated}\}$. Thus $X \leq \bigvee_{i=1}^n J_i^*$ for some finitely generated $J_i \leq \bigvee_\alpha I_\alpha$, since X is compact [15, Corollary 1.28.7]. Set $J = \bigvee_{i=1}^n J_i$, then J is finitely generated and $J \leq \bigvee_\alpha I_\alpha$, $X \leq J^*$. Now we claim that $J \leq I_\alpha$ for some $\alpha \in A$. Indeed, $J = X_1 \vee \cdots \vee X_n$ for some principal X_i , and since $\{I_\alpha \mid \alpha \in A\}$ is a chain and each X_i is compact, $X_i \leq J \leq \bigvee_\alpha I_\alpha$ implies $X_i \leq I_{\alpha_i}$ for some $\alpha_i \in A$. Thus $J \leq \bigvee_{i=1}^n I_{\alpha_i} = I_\alpha$ where $I_\alpha = \max_{1 \leq i \leq n} (I_{\alpha_i})$. Therefore $X \leq J^* \leq I_\alpha^* \leq \bigvee_\alpha I_\alpha^*$, and we have $\bigvee_\alpha I_\alpha^* = (\bigvee_\alpha I_\alpha)^*$. It remains to show that $\bigvee_\alpha I_\alpha \in S'$. Assume that $(\bigvee_\alpha I_\alpha)^* \wedge R = R$. Then $R \leq (\bigvee_\alpha I_\alpha)^* = \bigvee_\alpha I_\alpha^*$, so $R \leq I_\alpha^*$ for some $\alpha \in A$ since R is compact and $\{I_\alpha \mid \alpha \in A\}$ is a chain. Then $I_\alpha^* \wedge R = R$, which is a contradiction. Thus $\bigvee_\alpha I_\alpha \in S'$, and S' has a maximal element by Zorn's lemma.

2. Every maximal element of S' is prime.

Let P be a maximal element of S' . Then suppose that $X, Y \in \mathcal{I}$ with $X \not\leq P, Y \not\leq P$. We will assume that $XY \leq P$ and derive a contradiction. We have $P < P \vee X$, so by maximality $(P \vee X)^* \geq R$ and $(P \vee X)^* = R^*$. Then $Y(P \vee X) = (YP \vee YX) \leq P$, so we have $Y \leq YR^* \wedge R = Y(P \vee X)^* \wedge R \leq (Y(P \vee X)^* \wedge R) \leq P^* \wedge R$. But since

$P \leq P^* \wedge R$ and $P^* \wedge R \in S$, $P^* \wedge R = P$ by maximality, and it follows that $Y \leq P$, which is a contradiction. \square

The proof of following corollary is now immediate.

Corollary 6.3.11. *Let $*$ be a semistar operation of finite type on \mathcal{L} and set $*\text{Max}(\mathcal{I})$ be the set of maximal elements of $\{I \mid 0 \neq I \leq R, I^* \wedge R \neq R\}$. Then for $I \leq R$ with $I^* \wedge R \neq R$, there exists a prime element $P \in *\text{Max}(\mathcal{I})$ such that $I \leq P$.*

Lemma 6.3.12. *(cf. [21, Lemma 4.2]) Let Δ be a nonempty set of prime elements of \mathcal{I} . Then $*^\Delta = *_{\mathcal{F}(\Delta)}$ and $\mathcal{F}^{*\Delta} = \mathcal{F}(\Delta)$.*

Remark 6.3.13. *(cf. [21, Remark 4.5]) If Δ is a nonempty subset of $\text{Spec}(\mathcal{I})$, then $\mathcal{F}(\Delta) = \mathcal{F}(\Delta')$ where $\Delta' = \{Q \in \text{Spec } R \mid Q \leq P \text{ for some } P \in \Delta\}$. In fact, $\mathcal{F}(\Lambda) = \mathcal{F}(\Delta)$ for any Λ with $\Delta \subset \Lambda \subset \Delta'$, so we have $*^\Delta = *^\Lambda$.*

Proof. Note that $\Delta \subset \Lambda$ implies $\mathcal{F}(\Lambda) \subset \mathcal{F}(\Delta)$. Thus it suffices to show that $\mathcal{F}(\Delta) \subset \mathcal{F}(\Delta')$. But $I \in \mathcal{F}(\Delta) \Rightarrow I \not\leq P$ for every $P \in \Delta \Rightarrow I \not\leq Q$ for every $Q \in \Delta' \Rightarrow I \in \mathcal{F}(\Delta')$. The last assertion follows from Lemma 6.3.12. \square

Consider the set $\Pi^* = \{P \mid P \text{ is a nonzero prime element of } \mathcal{I}, P^* \wedge R \neq R\}$. If this set is nonempty, then we call $*_{sp} = *^{\Pi^*}$ the *spectral semistar operation associated to $*$* .

6.4 Invertibility of semistar operations on q.f. lattices

In this section, we will consider the invertibility of semistar operations on q.f. lattices.

Definition 6.4.1. Let \mathcal{L} be a q.f. lattice, R' a ring element of \mathcal{L} , and $*$ a semistar operation on $\mathcal{L}(R')$. For $A \in \mathcal{L}(R') \setminus \{0\}$ we say that A is **-invertible in $\mathcal{L}(R')$* (respectively, *quasi *-invertible in $\mathcal{L}(R')$*) if $(A(R' : A))^* = R'^*$ (respectively, $(AB)^* = R'^*$ for some $B \in \mathcal{L}(R') \setminus \{0\}$).

From now on, we will use the term *-invertible (respectively, quasi-*-invertible) instead of *-invertible in $\mathcal{L}(R)$ (respectively, quasi *-invertible in $\mathcal{L}(R)$). Note that every *-invertible element is quasi *-invertible, but the converse may not be true ([25, Example 2.9]).

Lemma 6.4.2. *Given $A \in \mathcal{L}$, A is quasi *-invertible in \mathcal{L} if and only if A is *-invertible in $\mathcal{L}(R^*)$.*

Proof. Let A be a quasi-*-invertible element of \mathcal{L} so $(AB)^* = R^*$ for some $B \in \mathcal{L}$. Then $B \leq R^* : A$, and $R^* = (AB)^* \leq (A(R^* : A))^* \leq R^*$. Thus A is a *-invertible element of $\mathcal{L}(R^*)$. The other implication is obvious. \square

The following generalizes [44, Proposition 5.1.2].

Proposition 6.4.3. *Let \mathcal{L} be a q.f. lattice and $*$ a (semi)star operation of finite type on \mathcal{L} . For an element $A \in \mathcal{L}'$, TFAE:*

1. A is *-invertible.
2. $J \leq AA^{-1}$ for some finitely generated $J \in \mathcal{F}^*$.
3. A^* is *-invertible.
4. A is quasi *-invertible.

Proof. 1 \Rightarrow 2: Let $(AA^{-1})^* = R^*$. Then $AA^{-1} \in \mathcal{F}^*$. Since $*$ is of finite type, so is \mathcal{F}^* by Proposition 6.3.7. Thus $J \leq AA^{-1}$ for some finitely generated $J \in \mathcal{F}^*$.

2 \Rightarrow 3: Suppose that $J \leq AA^{-1}$ for some finitely generated $J \in \mathcal{F}^*$. Then $A^*A^{-1} \geq J$,

so $R^* = J^* \leq (A^*A^{-1})^* = (AA^{-1})^* \leq R^*$, and $(A^*A^{-1})^* = R^*$.

3 \Rightarrow 4: It is an immediate consequence of Lemma 6.4.2, since $R^* = R$.

4 \Rightarrow 1: Since $(A^*B)^* = (AB)^*$ for any $A, B \in \mathcal{L}'$, it is an immediate consequence of Lemma 6.4.2. \square

The following generalizes [44, Proposition 5.1.5].

Proposition 6.4.4. *Let \mathcal{L} be a q.f. lattice, $*$ a semistar operation of finite type on \mathcal{L} and $A \in \mathcal{L}'$ a $*$ -invertible element. Then A^* is $*$ -finite.*

Proof. By the preceding proposition, $J \leq AA^{-1}$ for some finitely generated $J \in \mathcal{F}^*$. Let $\{a_i\}_{i \in I}$ be a set of principal elements such that $A = \bigvee_{i \in I} a_i$. Then $J \leq (\bigvee_{i \in I} a_i)A^{-1} = \bigvee_{i \in I} a_iA^{-1}$, and since J is compact ([15, Corollary 1.28.7]), for some finitely many indices $i_k \in I$ we have $J \leq \bigvee_{i_k}^n a_{i_k}A^{-1}$, so $A^* = (AJ)^* \leq (\bigvee_{i_k=1}^n a_{i_k})^* \leq A^*$, and A^* is $*$ -finite. \square

Notice that, the theorem in commutative ring theory that every invertible ideal of an integral domain is finitely generated ([41, Theorem 58]), can be obtained by letting $*$ be the identity operation in Proposition 6.4.4.

The following theorem generalizes [39, Theorem 2.1], whose proof can be easily adapted to q.f. lattices.

Theorem 6.4.5. *Let \mathcal{L} be a q.f. lattice and $*$ a semistar operation on \mathcal{L} of finite type such that every prime $*$ -element of \mathcal{I} is $*$ -invertible. Then every $*$ -element of \mathcal{I} is $*$ -invertible.*

Recall that if a prime element of a q.f.lattice \mathcal{L} can be written as $(A :_{\mathcal{I}} B)$ for some $A, B \in \mathcal{L}$ with $B \not\leq A$ and B a principal element, then we call that prime element an *associated prime element* of A . We say a prime element P of a q.f.lattice \mathcal{L}

is a *weakly associated prime element* of A if P is a minimal prime of $(A :_{\mathcal{I}} B)$ for some principal element B with $B \not\leq A$.

The following lemma is an analogous form of [39, Lemma 1.2] in a q.f.lattice.

Lemma 6.4.6. *Let \mathcal{L} be a q.f.lattice. Then for any prime element $P \in \mathcal{I}$ such that $PP^{-1} \not\leq P$, P is an associated prime element of a principal element.*

Proof. Since $PP^{-1} \leq P$, there exists principal elements $X, Y \in \mathcal{I}$ such that $X \leq P, Y \leq P^{-1}, XY \not\leq P$. Suppose that $X \leq Q < P$ for some prime element Q . Then there exists a principal element $Z \in \mathcal{I}$ such that $Z \leq P$ and $Z \not\leq Q$. Now $XY \leq PP^{-1} \leq R$, and $XY \not\leq Q$ since $XY \not\leq P$. Hence $(XY)Z \not\leq Q$ since Q is prime, but at the same time $XYZ \leq QR = Q$, which is a contradiction. Therefore P is a minimal prime of X . Now we claim that $P = (X :_{\mathcal{I}} XY)$. Indeed, since $XY P \leq XP^{-1}P \leq XR \leq X$, so $P \leq (X :_{\mathcal{I}} XY)$. Conversely, if there exists $W \leq (X :_{\mathcal{I}} XY)$, then $W \in \mathcal{I}, XYW \leq X \leq P$, and $XY \not\leq P$. Thus $W \leq P$ since P is prime, and thereby $(X :_{\mathcal{I}} XY) \leq P$, and the claim follows. Since the product of two principal elements is principal ([15, Lemma 1.10.3]), the proof of our lemma is immediate. \square

Corollary 6.4.7. *Let \mathcal{L} be a q.f. lattice and $*$ a semistar operation on \mathcal{L} . Then every $*$ -invertible prime $*$ -element of \mathcal{I} is an associated prime element of a principal element.*

Proof. If $P \in \mathcal{I}$ is a $*$ -invertible prime $*$ -element, then $(PP^{-1})^* = R$ and $P^* < R$, so $PP^{-1} \not\leq P$. Now the conclusion follows from Lemma 6.4.6. \square

Proposition 6.4.8. *(cf. [32, Proposition 1.1(5)]) Let $*$ is a semistar operation that is stable and of finite type on a q.f. lattice \mathcal{L} . Then every prime element of \mathcal{I} minimal over a $*$ -element is a $*$ -element.*

Proof. Change w to $*$ in the proof of [44, Lemma 4.5.16]. \square

Theorem 6.4.9. *For a q.f.lattice \mathcal{L} , let $B(\mathcal{L})$ (respectively, $B_w(\mathcal{L})$) be the set of associated prime (respectively, weakly associated prime) elements of principal elements of \mathcal{L} . If $*$ is a (semi)star operation of finite type on \mathcal{L} such that every maximal $*$ -element is $*$ -invertible, then the spectral semistar operations induced by $*Max(\mathcal{I})$, $B_w(\mathcal{L})$ and $B(\mathcal{L})$ coincide.*

Proof. For a nonempty set Δ of prime elements of \mathcal{L} , set $\Delta' = \{P \mid P \text{ is a prime element and } P \leq Q \text{ for some } Q \in \Delta\}$. We will show that $*Max(\mathcal{I}) \subset B(\mathcal{L}) \subset B_w(\mathcal{L}) \subset *Max(\mathcal{I})'$; then by Remark 6.3.13 and Lemma 6.3.12, the theorem will follow.

1. $*Max(\mathcal{I}) \subset B(\mathcal{L})$: Let $P \in *Max(\mathcal{I})$. Then by assumption, P is $*$ -invertible. It follows that $P^* < R$ and $(PP^{-1})^* = R$, so $PP^{-1} \not\leq P$. Hence by Corollary 6.4.7, $P \in B(\mathcal{L})$.
2. $B(\mathcal{L}) \subset B_w(\mathcal{L})$: Obvious from definition.
3. $B_w(\mathcal{L}) \subset *Max(\mathcal{I})'$: Let $P \in B_w(\mathcal{L})$. Then P is a minimal prime over $I = (A :_{\mathcal{I}} B)$ for some principal elements $A, B \in \mathcal{I}$ with $B \not\leq A$. It follows that $I^* = (A :_{\mathcal{I}} B)^* \leq (A^* :_{\mathcal{I}(\mathcal{R}^*)} B) = (A :_{\mathcal{I}} B) = I$, so I is a $*$ -element. Thus by Proposition 6.4.8, P is a $*$ -element and by Lemma 6.3.11, there exists $Q \in *Max(\mathcal{I})$ such that $P \leq Q$. Thus $P \in *Max(\mathcal{I})'$. □

Remark 6.4.10. *Note that above theorem also holds if $*$ is a spectral semistar operation.*

Lastly, we consider the lattice version of Krull domains, and prove a corollary of Theorem 6.4.9.

Definition 6.4.11. Let \mathcal{L} be a q.f. lattice. Then the *height* of a prime element P is defined to be $\sup\{n \mid 0 \leq P_1 \leq P_2 \leq \cdots \leq P_n = P, P_i \text{ prime elements of } \mathcal{I}\}$. \mathcal{L} is a *valuation lattice* if the set of \mathcal{L} -principal elements are totally ordered under \leq .

Definition 6.4.12. [63, Definition 15] Let \mathcal{L} be a q.f. lattice and \mathcal{P} the set of prime element of height one. Then \mathcal{L} is a *Krull lattice* if

1. $\mathcal{I}(R_P)$ is a Noetherian valuation lattice for each $P \in \mathcal{P}$.
2. Given an \mathcal{L} -principal element $I \leq R$, $I \leq P$ for only finitely many $P \in \mathcal{P}$.
3. $R = \wedge\{R_P \mid P \in \mathcal{P}\}$.

Corollary 6.4.13. *If \mathcal{L} is a q.f. lattice and \mathcal{I} is a Krull lattice, then $w = *^{B_w(\mathcal{L})} = *^{B(\mathcal{L})}$.*

Proof. By Theorem 6.4.9, it is enough to show that each w -element is w -invertible. Let \mathcal{L} be a Krull lattice and let A be a w -element of \mathcal{I} . Then by [15, Theorem 4.27] and [15, Lemma 4.11], $(AA^{-1})^{-1} = R$, which means $(AA^{-1})_v = R$. Also, by [15, Lemma 4.19], there exists finitely generated $J \leq AA^{-1}$ such that $(AA^{-1})_v = J_v$. Then $J \leq R$, $J_v = R$ and $R \geq J_w = \vee\{J : I \mid I_v = R, I \leq R \text{ and } I \text{ is finitely generated}\} \geq J : J \geq R$, so $J \in \mathcal{F}^w$. Now from Proposition 6.4.3, it follows that A is w -invertible. \square

Chapter 7

Further questions

The author was unable to answer the following questions.

1. From Lemma 4.1.7 it follows that if R is coherent, then $(\bar{*})_f$ is stable for each semistar operation $*$ on R . What could be the conditions on the semistar operations on R so the converse is also true, if such conditions exist?
2. What could be said of an integral domain R such that $* = *_{\mathcal{F}^v}$ for each semistar operation $*$ on R ?
3. When is $*_{\mathcal{F}^v}$ neither stable nor of finite type? If there is an integrally closed domain R that is neither a v -domain nor an H-domain (recall that R is a v -domain if I is v -invertible for all $I \in f(R)$, and an H-domain if \mathcal{F}^v is of finite type. cf.[26, Theorem 2.4], [68, Proposition 4.15]), then $v_{\mathcal{F}^v}$ is neither stable nor of finite type. Indeed, v is not finite stable ([2, Theorem 3.2]), so by Lemma 4.1.4(b), $v_{\mathcal{F}^v}$ is not stable. On the other hand, since R is not an H-domain, \mathcal{F}^v is not of finite type, and \bar{v} is not of finite

type (if \bar{v} is of finite type, then by Theorem 2.1.6, $\mathcal{F}^{\bar{v}} = \mathcal{F}^v$ is of finite type, which is a contradiction). Hence by Lemma 4.1.4(c) v_g is not of finite type.

4. If R has property $*$, then is R divided (i.e., for each $r \in R$ and a nonzero prime ideal P of R , either $r \in P$ or $P \subseteq rR$)? Note that this is true for Noetherian domains since a Noetherian domain with property $*$ is one-dimensional quasilocal.

5. Is there a c^* -domain that is not a t^* -domain? The set of c^* -domains and that of t^* -domains coincide on stable domains (Lemma 4.5.9), PvMDs (Lemma 4.5.10), numerical semigroup rings (Lemma 5.3.9), completely integrally closed domains (Lemma 5.4.1), integrally closed Mori domains (Corollary 5.3.2) and Noetherian quasilocal domains with infinite residue field having only finitely many star operations (Lemma 5.3.5).

6. Let R be an integrally closed domain. If R is a c^* -domain, is it necessarily true that R is a valuation domain? What if R has property $*$?

7. Does every t^* -domain have property $*$? This holds true for integrally closed domains and PVDs.

8. If R has infinitely many star operations, is Lemma 5.3.5 still true?

Bibliography

- [1] D. D. Anderson and D. F. Anderson, *Some Remarks on Cancellation Ideals*, Math Japonica, **29**(6) (1984), 879-886.
- [2] D. D. Anderson and S. M. Clarke, *When the v -operation Distributes over Intersections*, Comm. Alg., **34**(12), (2006), 4327-4337 .
- [3] D. F. Anderson, A. Badawi and D. E. Dobbs, *Pseudo-valuation rings. II*, Boll. Un. Mat. Ital. Serie 8, Vol. **3-B** (2000), n.2, 535-545.
- [4] D. F. Anderson and D. E. Dobbs, *Pairs of rings with the same prime ideals*, Canad. J. Math., **32** (1980), 362-384.
- [5] D. F. Anderson, D. E. Dobbs and J. A. Huckaba, *On seminormal overrings*, Comm. Alg., **10** (1982), 1421-1448.
- [6] D. D. Anderson and M. Roitman, *A characterization of cancellation ideals*, Proc. Amer. Math. Soc., **125**(10) (1997), 2853-2854.
- [7] S. El Baghdadi, M. Fontana and G. Picozza, *Semistar Dedekind domains*, J. Pure Appl. Algebra, **193**(1-3), (2004), 2760 .
- [8] S. El Baghdadi and S. Gabelli, *w -Divisorial domains*, J. Algebra, **285**(1) (2005), 335-355 .
- [9] V. Barucci, *Strongly divisorial ideals and complete integral closure of an integral domain*, J. Algebra, **99**(1) (1986), 132-142.
- [10] V. Barucci, D. E. Dobbs and M. Fontana, *Conducive integral domains as pullbacks*, Manuscripta Math., **54** (1986), 261-277
- [11] V. Barucci, E. Houston, T. G. Lucas and I. J. Papick, *m -canonical ideals in integral domains II*, Ideal theoretic methods in commutative algebra, D.D. Anderson and I.J. Papick, eds., Lecture Notes in Pure and Applied Mathematics, **220**, 89-108, Marcel Dekker, Inc., New York, 2001.
- [12] E. Bastida and R. Gilmer, *Overrings and divisorial ideals of Rings of the form $D+M$* , Michigan Math. J., **20**(1) (1973), 79-95.
- [13] S. Bazzoni and L. Salce, *Warfield domains*, J. Algebra **185**(3) (1996), 836-868.
- [14] D. P. Brithinee, *Ring elements and integral dependence in q -Lattices*, Dissertation, University of California Riverside, March 1971.

- [15] W. P. Brithinee, *Construction of quotient lattices and the Artin relation in a q. f. lattice*, Dissertation, University of California Riverside, March 1971.
- [16] R. P. Dilworth, *Abstract commutative ideal theory*, Pacific J. Math., **12** (1962), 481-498.
- [17] D. E. Dobbs and R. Fedder, *Conducive integral domains*, J. Algebra, **86**(2) (1984), 494-510.
- [18] D. E. Dobbs, E. Houston, T. G. Lucas and M. Zafrullah, *t-linked overrings and Prüfer v-multiplication domains*, Comm. Alg., **17**(11) (1989), 2835-2852.
- [19] D. E. Dobbs, E. Houston, T. G. Lucas, M. Roitman and M. Zafrullah, *On t-linked overrings*, Comm. Alg., **20**(5) (1992), 1463-1488.
- [20] M. Fontana, *Carres cartesiens et anneaux de pseudo-valuation*, Publ. Math. Univ. Lyon, **17** (1980), 57-95.
- [21] M. Fontana and J. A. Huckaba, *Localizing systems and Semistar operations*, Non-Noetherian commutative ring theory, 169-197, Math. Appl., 520, Kluwer Acad. Publ., Dordrecht, 2000.
- [22] M. Fontana, J. A. Huckaba and I. J. Papick, *Prüfer domains*, Marcel Dekker, New York, 1997.
- [23] M. Fontana, P. Jara and E. Santos, *Prüfer *-multiplication Domains*, Journal of Algebra and Its Applications, **2**(1) (2003), 21-50.
- [24] M. Fontana and K. A. Loper, *Kronecker function rings; a general approach*, Ideal theoretic methods in commutative algebra, D.D. Anderson and I.J. Papick, eds., Lecture Notes in Pure and Applied Mathematics, **220**, 189-205, Marcel Dekker, Inc., New York, 2001.
- [25] M. Fontana and G. Picozza, *Semistar invertibility on integral domains*, Algebra Colloquium, **12**(4) (2005), 645-664.
- [26] M. Fontana and M. Zafrullah, *On v-domains: a survey. (English summary)*, Commutative algebra - Noetherian and non-Noetherian perspectives, 145-179, Springer, New York, 2011.
- [27] L. Fuchs and L. Salce, *Modules over Non-Noetherian domains*, Mathematical Surveys and Monographs, 84. American Mathematical Society, Providence, RI, 2001.
- [28] J. C. García-Sánchez and P. A. Rosales, *Numerical semigroups*, (First. ed.), New York: Springer, 2009.
- [29] R. Gilmer, *Multiplicative Ideal Theory*, Marcel Dekker, New York, 1972.
- [30] F. Halter-Koch, *Ideal Systems: An Introduction to Multiplicative Ideal Theory*, Marcel Dekker, New York, 1998.
- [31] J. R. Hedstrom and E. Houston, *Pseudo-valuation domains*, Pacific J. Math., **75**(1) (1978), 137-147.

- [32] J. R. Hedstrom and E. Houston, *Some remarks on star-operations*, J. of Pure and Applied Algebra, **18** (1980), 37-44.
- [33] W. J. Heinzer, *Integral domains in which each non-zero ideal is divisorial*, Mathematika, **15**(1968), 164-170.
- [34] W. J. Heinzer, J. A. Huckaba and I. J. Papick, *m-canonical ideals in integral domains*, Comm. Alg., **26**(9) (1998), 3021-3043.
- [35] E. Houston, A. Mimouni, and M. H. Park, *Integral domains which admit at most two star operations*, Comm. Alg., **39**(5) (2011), 1907-1921.
- [36] E. Houston, A. Mimouni, and M. H. Park, *Integrally closed domains with only finitely many star operations*, Comm. Alg., **42**(12) (2014), 5264-5286.
- [37] E. Houston, A. Mimouni, and M. H. Park, *Noetherian domains which admit only finitely many star operations*, J. Algebra, **366** (2012), 78-93.
- [38] E. Houston, A. Mimouni, and M. H. Park, *Star operations on overrings of Noetherian domains*, J. of Pure and Applied Algebra, **220** (2016), 810-821.
- [39] E. Houston and M. Zafrullah, *On t-invertibility. II*, Comm. Alg., **17** (1989), no. 8, 1955-1969.
- [40] P. Jaffard, *les systèmes d'idéaux*, Travaux et Recherches Mathématiques, IV. Dunod, Paris, 1960.
- [41] I. Kaplansky, *Commutative Rings*, Allyn and Bacon, Boston, 1970.
- [42] W. Krull, *Idealtheorie*, Springer Verlag, Berlin, 1935.
- [43] M. D. Larsen and P. J. McCarthy, *Multiplicative Theory of Ideals*, Academic Press, New York and London, 1971.
- [44] D. Majcherek, *Multiplicative lattice versions of some results from Noetherian commutative rings*, Dissertation, University of California Riverside, August 2014
- [45] E. Matlis, *Reflexive domains*, J. Algebra, **8**(1), (1968), 1-33.
- [46] R. Matusda, *Note on the number of semistar operations, XI*, Math. J. Ibaraki Univ., **39** (2007), 11-22.
- [47] R. Matsuda and A. Okabe, *Semistar-operations on integral domains*, Math. J. Toyama Univ., **17** (1994), 1-21.
- [48] R. Matsuda and I. Sato, *Note on semistar operations and star operations*, Bull. Fac. Sci. Ibaraki Univ., **28** (1996), 5-22.
- [49] R. Matsuda and T. Sugatani, *Semistar-operations on integral domains, II*, Math. J. Tayama Univ., **18** (1995), 155-161.
- [50] H. Matsumura, *Commutative Ring Theory*, Cambridge University Press, Cambridge, 1986.
- [51] A. Mimouni, *On the set of t-linked overrings of an integral domain*, Manuscripta Math., **128**(2) (2009), 147-162.

- [52] A. Mimouni, *TW-domains and Strong Mori domains*, J. Algebra, **177** (2003), 79-93.
- [53] A. Mimouni and M. Samman, *On the cardinality of semistar operations on integral domains*, Comm. Alg., **33**(9) (2005), 3311-3321.
- [54] A. Mimouni and M. Samman, *Semistar-operations on valuation domains*, Focus on commutative rings research, 131-141, Nova Sci. Publ., New York, 2006.
- [55] A. Mimouni and M. Samman, *Characterizations of Some Classes of Integral Domains via Semistar Operations*, Comm. Alg., **38**(4) (2010), 1341-1350.
- [56] J. Ohm, *Some counterexamples related to the integral closure in $D[[X]]$* , Trans. Amer. Math.Soc., **122**(2) (1966), 321-333.
- [57] A. Okabe, *Note on a Fontana-Huckaba's open problem*, JP Journal of Algebra, Number Theory and Applications **5**(1) (2005), 17-23.
- [58] A. Okabe, *On generalized Dedekind domains*, Math. J. Ibaraki Univ., **36** (2004), 5-23.
- [59] A. Okabe, *Semistar operations on conducive domains*, Math. J. Ibaraki Univ., **35** (2003), 11-19.
- [60] A. Okabe, *Some ideal theoretical characterizations of divided domains*, Houston J. Math, **12**(4) (1986), 563-577.
- [61] A. Okabe, *Some results on pseudo-valuation domains*, Tsukaba Journal of Mathematics, **8**(2) (1984), 333-338.
- [62] A. Okabe and R. Matsuda, *Semistar-operations on integral domains*, Math. J. Toyama Univ., **17** (1994), 1-21.
- [63] J. S. Okon, D. E. Rush and L. J. Wallace, *A Mori-Nagata theorem for lattices and graded rings*, Houston J. Math., **31** (2005), 973-997.
- [64] B. Olberding, *Globalizing local properties of Prüfer domains*, J. Algebra, **205** (1998), 480-504.
- [65] B. Olberding, *Stability, duality, 2-generated ideals and a canonical decomposition of modules*, Rend. Sem. Mat. Univ. Padova, **106**, (2001), 261-290.
- [66] B. Olberding, *On the structure of stable domains*, Comm. Alg., **30**(2) (2002), 877-895.
- [67] M. H. Park, *On the cardinality of star operations on a Pseudo-valuation domain*, Rocky Mountain Journal of Mathematics, **42**(6) (2012), 1939-1951.
- [68] G. Picozza, *Star operations on Overrings and Semistar operations*, Comm. Alg., **33**(6) (2005), 2051-2073.
- [69] G. Picozza, *Semistar Operations and Multiplicative Ideal Theory*, Dissertation, Università degli Studi Roma Tre, June 2004.

- [70] G. Picozza and F. Tartarone, *When the semistar operation $\tilde{*}$ is the identity*, Comm. Alg., **36**(5) (2008), 1954-1975.
- [71] J. Querre, *Sur une propriete des anneaux de Krull*, Bull. Sci. Math. 2 ser., **95** (1971) 341-354.
- [72] D. E. Rush, *Two-Generated Ideals and Representations of Abelian Groups over Valuation Rings*, J. Algebra, **177**(1) (1995), 77-101.
- [73] J. Vassilev, *A look at prime and semiprime operations of one-dimensional domains*, Houston J. Math., **38**(1) (2012), 115. 13A15
- [74] J. Vassilev, *Structure on the set of closure operations of a commutative ring*, J. Algebra, **321**(10) (2009), 2737-2753 .
- [75] Wang Fanggui and R. L. McCasland, *On strong Mori domains*, J. of Pure and Applied Algebra, **135** (1999), 155-165.
- [76] M. Zafrullah, *The v -operation and intersection of quotient of integral domains*, Comm. Alg., **13**(8) (1985), 1699-1712.

Index

- R' , 5
- \mathcal{F}^* , 9
- \mathcal{F}_f , 6
- \mathcal{I} , 88
- \mathcal{L} , 88
- $\mathcal{S}'(R)$, 5
- $\mathcal{S}(R)$, 5
- $\overline{F}(R)$, 5
- $f(R)$, 5
- $f\mathcal{S}(R)$, 5
- ideal
 - *-cancellation ideal, 13
 - *-invertible ideal, 13
 - divisorial ideal, 36
 - fractional ideal, 5
 - idempotent ideal, 68
 - invertible ideal, 13
 - m-canonical ideal, 38
 - stable ideal, 42
 - strongly prime ideal, 59
- integral domain
 - c^* -domain, 34
 - t^* -domain, 51
 - Mori domain, 74
 - P*MD, 29
 - PVD, 59
 - Prüfer domain, 31
 - conducive domain, 34
 - divisorial domain, 36
 - finite character, 39
 - generalized Dedekind domain, 33
 - h-local domain, 39
 - pm-domain, 39
 - property *, 39
 - stable domain, 42
 - strongly discrete domain, 36
 - super-t-linkative domain, 34
 - t-linkative domain, 34
 - t-linked overring, 34
 - totally divisorial domain, 36

- valuation domain, 29
 - weak property $*$, 39
- localizing system, 6
- of finite type, 6
- multiplicative lattice
- $*Max(\mathcal{I})$, 102
 - associated prime element, 104
 - cl-monoid, 88
 - compact element, 89
 - complete lattice, 88
 - finitely generated element, 89
 - integral lattice, 88
 - invertible element, 89
 - monoid, 88
 - prime element, 90
 - principal element, 89
 - q.f. lattice, 90
 - quasi- $*$ -invertible element, 102
 - weakly associated prime element, 104
- multiplicatively closed set of ideals, 6
- numerical semigroup, 79
- numerical semigroup ring, 79
- $O(\mathbb{R})$, 5
- overring, 5
- semistar operation, 7
- $*'$ -operation, 8
 - $*_T$, 8
 - $*_t$ -operation, 8
 - $*_g$, 25
 - d -operation, 8
 - t -operation, 8
 - v -operation, 8
 - $v(I)$, 8
 - w -operation, 8
 - finite stable, 25
 - $*_{\mathcal{F}}$, 9
 - $*_f$, 9
 - $\tilde{*}$, 9
 - of finite type, 9
 - spectral, 12
 - stable, 9
- SStar(\mathbb{R}), 8
- Star(\mathbb{R}), 8