

Lawrence Berkeley National Laboratory

Recent Work

Title

AUTOMATIC READER FOR AIR-MONITORING FILTER PAPER

Permalink

<https://escholarship.org/uc/item/04p8k76q>

Authors

Thaxter, M.D.

Taussig, Thomas.

Publication Date

1959-09-28

UNIVERSITY OF
CALIFORNIA

Ernest O. Lawrence

*Radiation
Laboratory*

AUTOMATIC READER FOR AIR-MONITORING

FILTER PAPER

BERKELEY, CALIFORNIA

DISCLAIMER

This document was prepared as an account of work sponsored by the United States Government. While this document is believed to contain correct information, neither the United States Government nor any agency thereof, nor the Regents of the University of California, nor any of their employees, makes any warranty, express or implied, or assumes any legal responsibility for the accuracy, completeness, or usefulness of any information, apparatus, product, or process disclosed, or represents that its use would not infringe privately owned rights. Reference herein to any specific commercial product, process, or service by its trade name, trademark, manufacturer, or otherwise, does not necessarily constitute or imply its endorsement, recommendation, or favoring by the United States Government or any agency thereof, or the Regents of the University of California. The views and opinions of authors expressed herein do not necessarily state or reflect those of the United States Government or any agency thereof or the Regents of the University of California.



UCRL-8701
Health and Safety
TID-4500 (15th Ed.)

UNIVERSITY OF CALIFORNIA

Lawrence Radiation Laboratory
Berkeley, California

Contract No. W-7405-eng-48

AUTOMATIC READER FOR AIR-MONITORING FILTER PAPER

M. D. Thaxter and Thomas Tausig

September 28, 1959

Printed for the U. S. Atomic Energy Commission

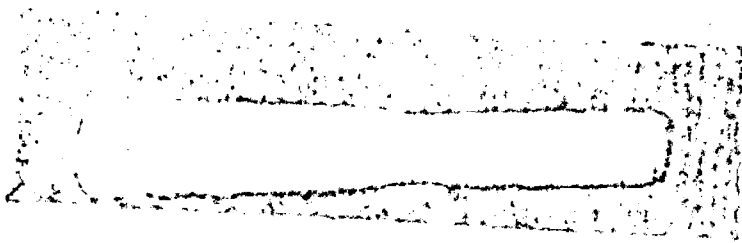

Printed in USA. Price 50 cents. Available from the
Office of Technical Services
U. S. Department of Commerce
Washington 25, D.C.

AUTOMATIC READER FOR AIR-MONITORING FILTER PAPER

M. D. Thaxter and Thomas Taussig

Lawrence Radiation Laboratory
University of California
Berkeley, California

September 28, 1959

ABSTRACT

An automatic reader has been developed for scanning 4×9-in. filter papers from the system that monitors particulate airborne activity at Lawrence Radiation Laboratory. Paper tape shows alpha and beta-gamma activities, together with counting times and identifying data, and for any samples exceeding a predetermined value a special indicator mark is added.

AUTOMATIC READER FOR AIR-MONITORING FILTER PAPER

M. D. Thaxter and Thomas Taussig

Lawrence Radiation Laboratory
University of California
Berkeley, California

September 28, 1959

At Lawrence Radiation Laboratory particulate airborne radioactivity is routinely monitored with 4×9-in. filter paper. On the average about 75 samples must be read daily for alpha and beta-gamma activity. This has had to be done without the aid of any automatic equipment owing to the lack of a commercially available automatic reader for the large 4×9-in. filter papers. Because the time of trained personnel is at a premium the counting period for each sample had to be kept to a practical minimum in spite of the consequent loss of reliability.

An automatic reader which can handle 4×9-in. filter paper was therefore developed for a preliminary scanning (Fig. 1). With this system, an operator needs only to load the day's samples into the machine and the next morning, upon returning to work, note the results, which are printed on paper tape. With this arrangement, the counting period per sample can be increased to as much as 10 minutes, depending upon the number of samples for that day.

On the paper tape are printed the alpha and beta-gamma activities, the serial number of the sample, the times when counting was begun and ended, and the date. An asterisk is printed alongside any reading that exceeds a preset action level. Any samples exceeding this value are later manually re-counted, and appropriate action is taken.

The filter papers are held by a "sandwich" (Fig. 2) consisting of a Lucite plate and a thin aluminum frame, hinged together by a strip of masking tape. These sandwiches are loaded into a gravity-feed hopper (Fig. 1) which can accommodate 87 samples. A gas-proportional counter (for reading alpha activity) and a lead-shielded scintillation counter (for reading beta-gamma activity) are mounted on a "reading tray" which is also gravity-operated (Fig. 3).

When operation is commenced the reading tray automatically drops one position every 6 sec until it is in line with the first sample in the loading hopper. The solenoid-operated plunger that initiates this dropping action then retracts momentarily, and sample slides along the reading tray until it is underneath a gas proportional counter. The alpha activity is then counted for a preset period, say 10 minutes. At the end of the counting period the control system (Fig. 4) causes another plunger to retract, allowing the sample to slide underneath the scintillation (β - γ) counter. In the meantime, the alpha level of the sample has been printed and compared with the preset action level; if this preset level was exceeded, an asterisk was printed.

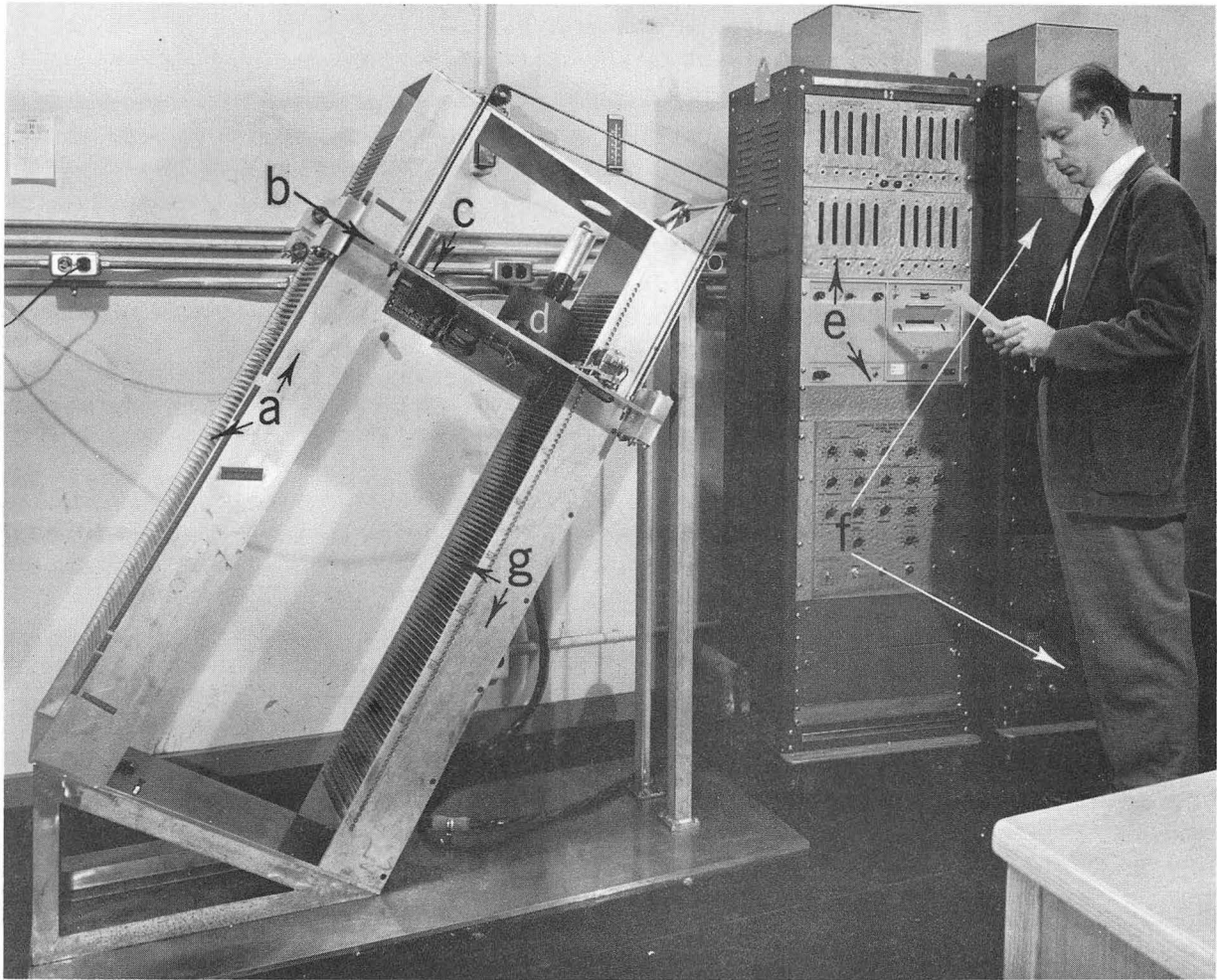

ZN-2247

Fig. 1. Automatic reader for filter papers from air-monitoring apparatus.
a. loading hopper
b. reading tray
c. gas proportional counter
d. scintillation counter
e. data-presenting panel and control system
f. power supply
g. receiving hopper .

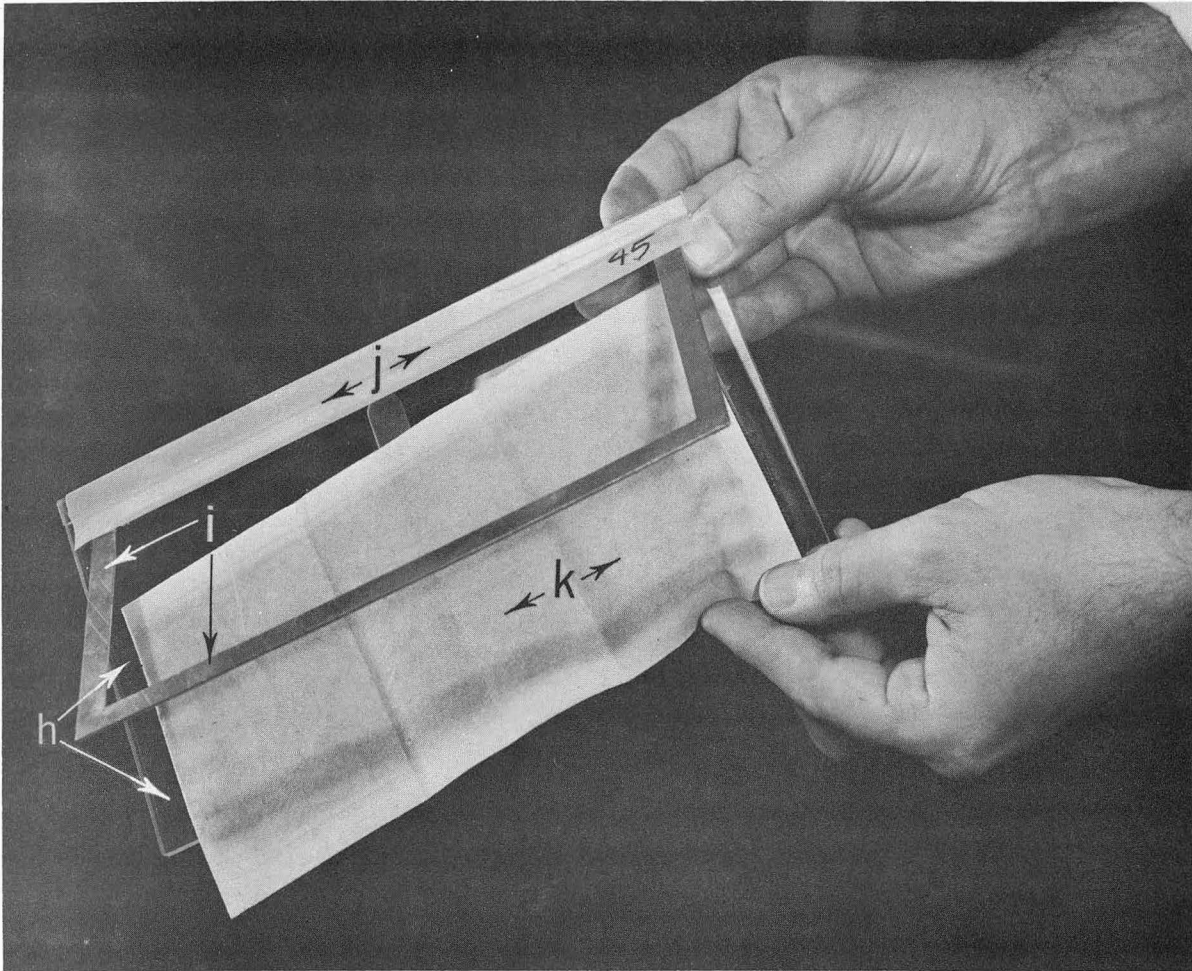

ZN-2250.

Fig. 2. Frame for holding 4 x 9-in. filter paper.
h. Lucite plate
i. aluminum frame
j. hinge made of masking tape
k. filter paper.

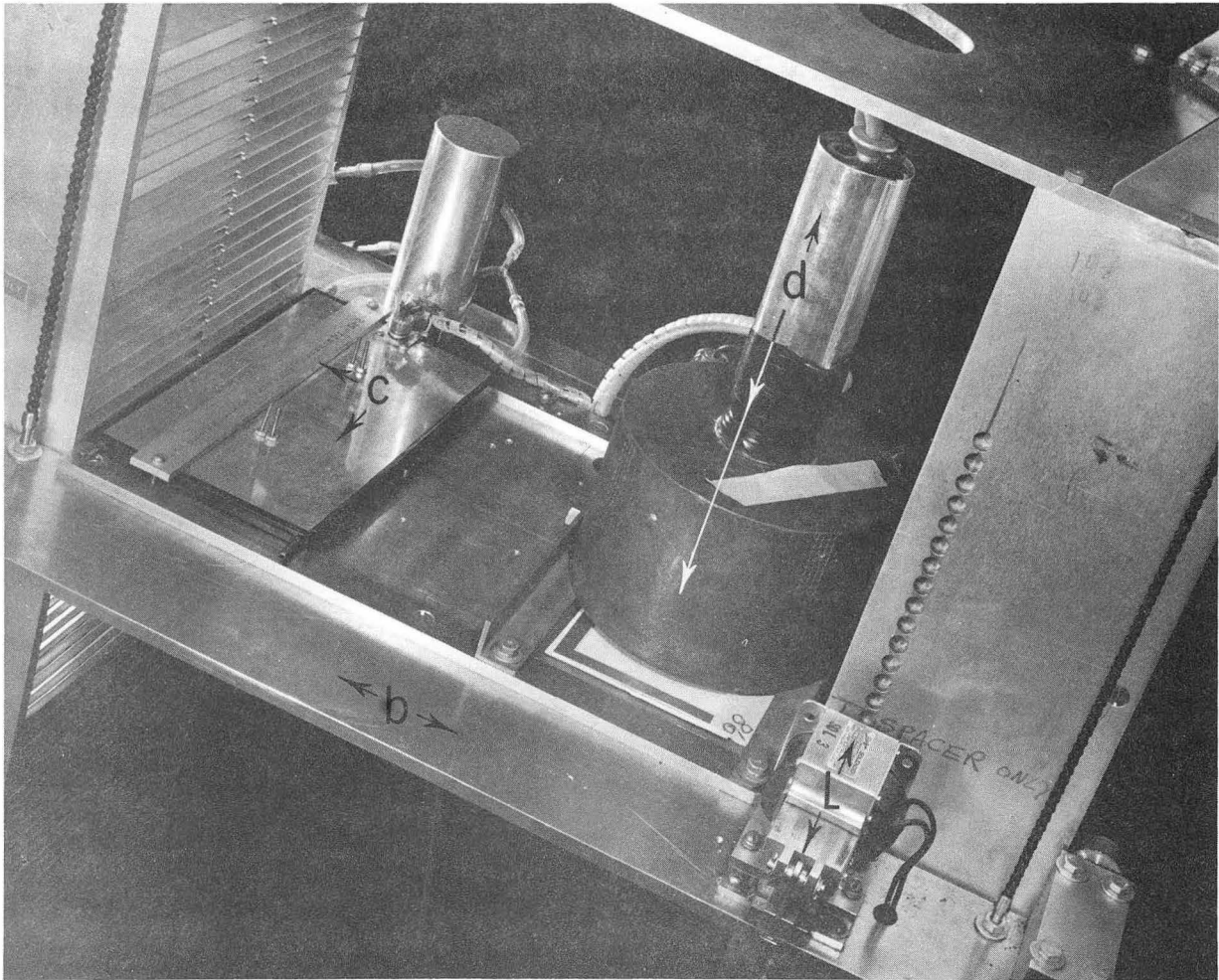

ZN-2249

Fig. 3. Reading tray, top view
b. tray
c. gas proportional counter
d. scintillation counter

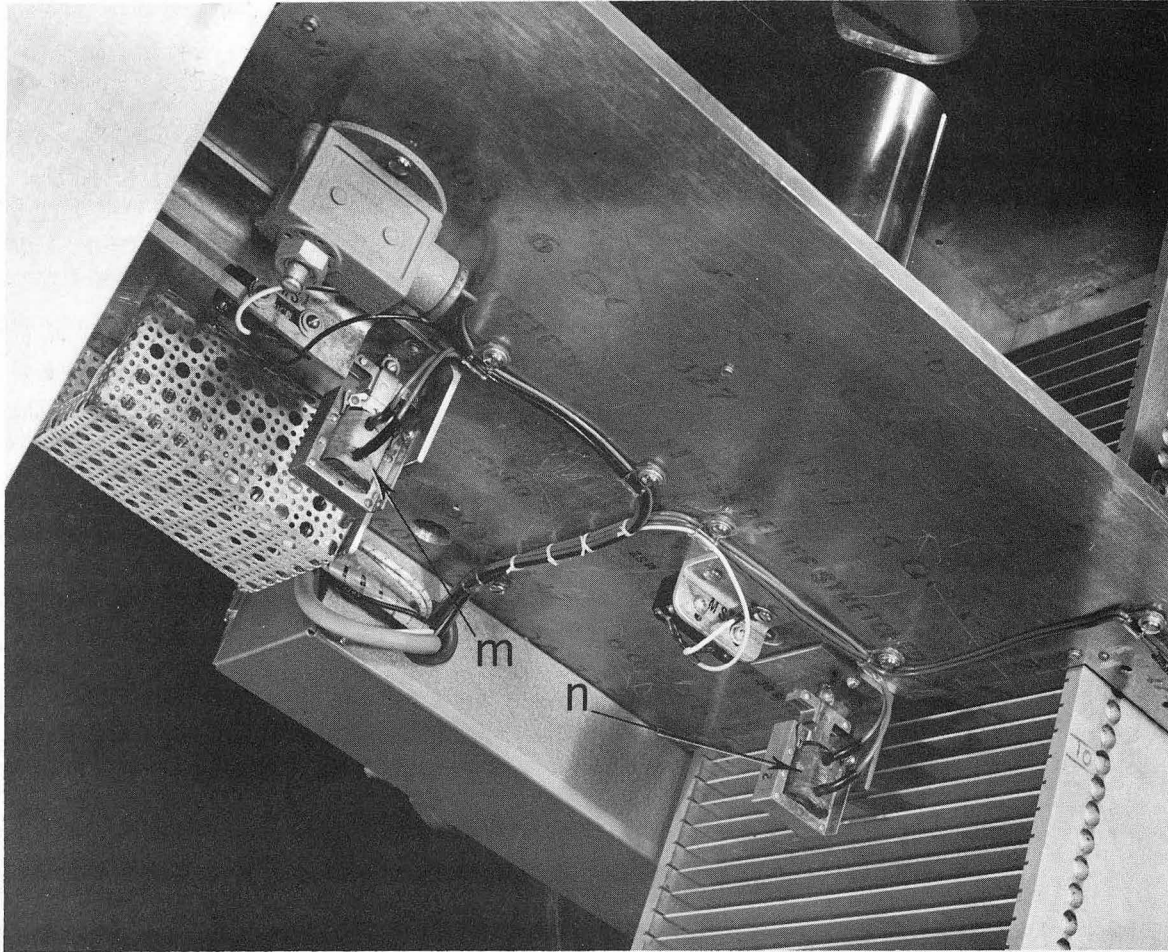

ZN-2248

Fig. 4. Underside of reading tray, showing solenoids that operate plungers (m) to move sample under scintillation counter, (n) to receiving hopper.

While sample No. 1 was sliding underneath the scintillation counter the reading tray dropped one position, allowing sample No. 2 to slide underneath the gas proportional counter. After the counting period has again elapsed, the control system causes the associated plungers to retract. Sample No. 1 slides into the receiving hopper, and sample No. 2 slides underneath the scintillation counter. The reading tray again drops one position, and sample No. 3 slides underneath the gas proportional counter, and so on.

If desired, the automatic sequencing can be interrupted at will by energizing the bypass switch. This permits manual recording of the activities of the samples on the reading tray. Further, a printed record of timed determinations on a single sample (as for decay studies) is obtained by flipping the "decay" switch.

Figure 5 is a system diagram of the automatic reader. Wherever possible, commercial assemblies were used. The control system was built on printed-circuit cards. Transistor circuitry and hermetically sealed relays were used throughout.

Sequence of Operation

A circuit diagram for this apparatus is shown in Fig. 6.

The "start" push button is gated by the +300-v power supply so that the reader cannot be started without the application of the proper voltages to the vacuum tube scalers; this is necessary because there is a 30-sec delay in the power supply circuit to allow for tube-heater warm-up. The +300-v supply is also interlocked with the -150-v supply.

If there are no sample trays in the α -counting position the start push button activates the "sample advance" one-shot multivibrator and the associated solenoids. If a sample tray is in position the start push button only resets the "program counter" and activates the "scaler reset" one-shot and the "count" flip-flop. The count flip-flop releases relays which allow pulses from the detectors to enter the α and β - γ scalers and pulses from the 10-pulse-per-minute "clock generator" to enter the "count interval timer."

At a tenth of a minute before the preset count interval has elapsed, the "count interval discriminator" opens a gate which allows the next clock pulse to start a print cycle if the mode switch is in the "decay" position, or to activate the "sample advance" one-shot; in both cases the count flip-flop is set so that no pulses may enter the scalers. In normal operation the sample trays are advanced. The sample tray sliding over the β - γ microswitch causes the "sample advance" one-shot to be reset, the "serial number counter" to be advanced one number, and the "print command delay" one-shot to be activated. The end of this print command delay activates the Hewlett-Packard 560A printer.

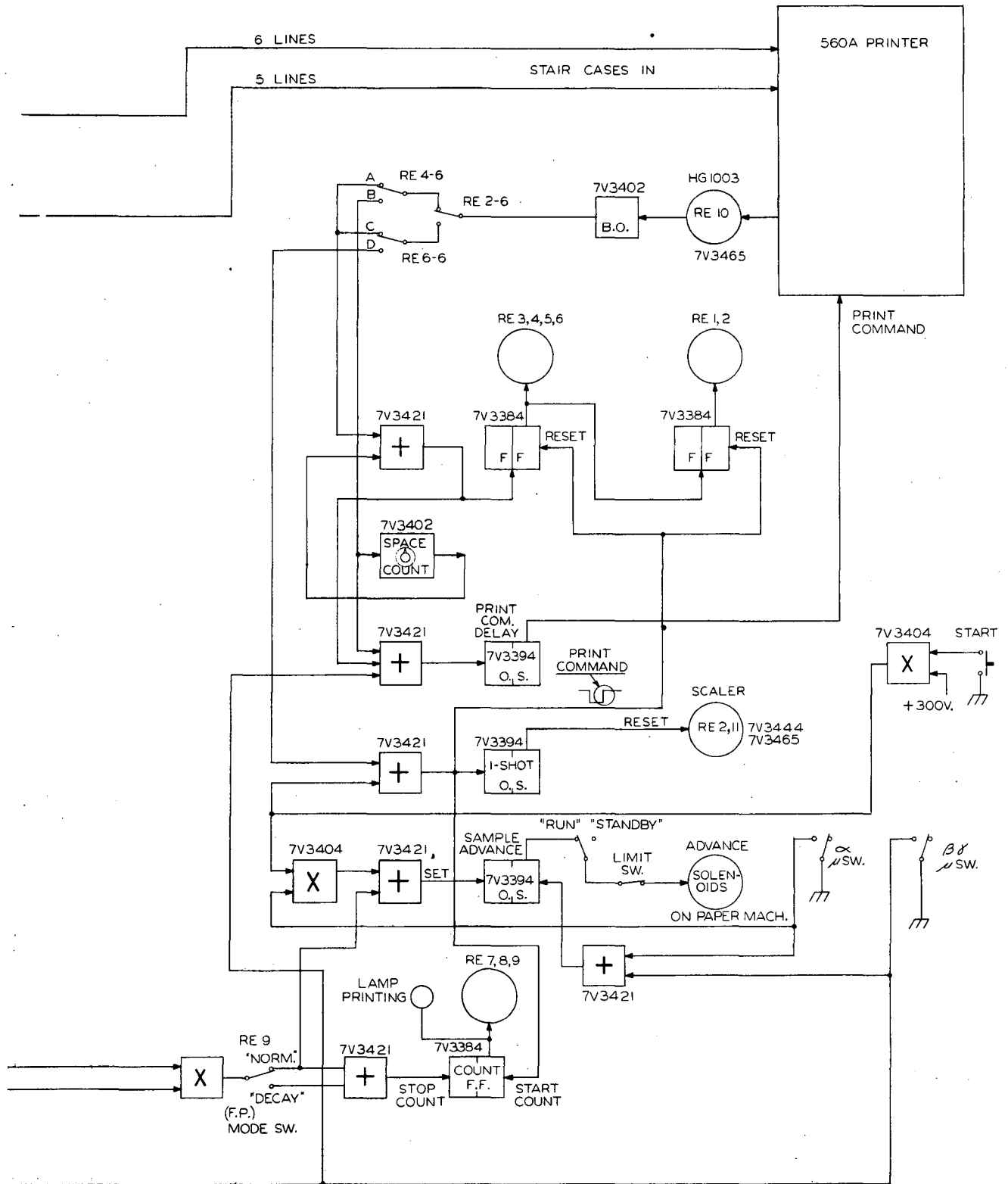

MUB - 369

Fig. 5. System diagram of the automatic reader.

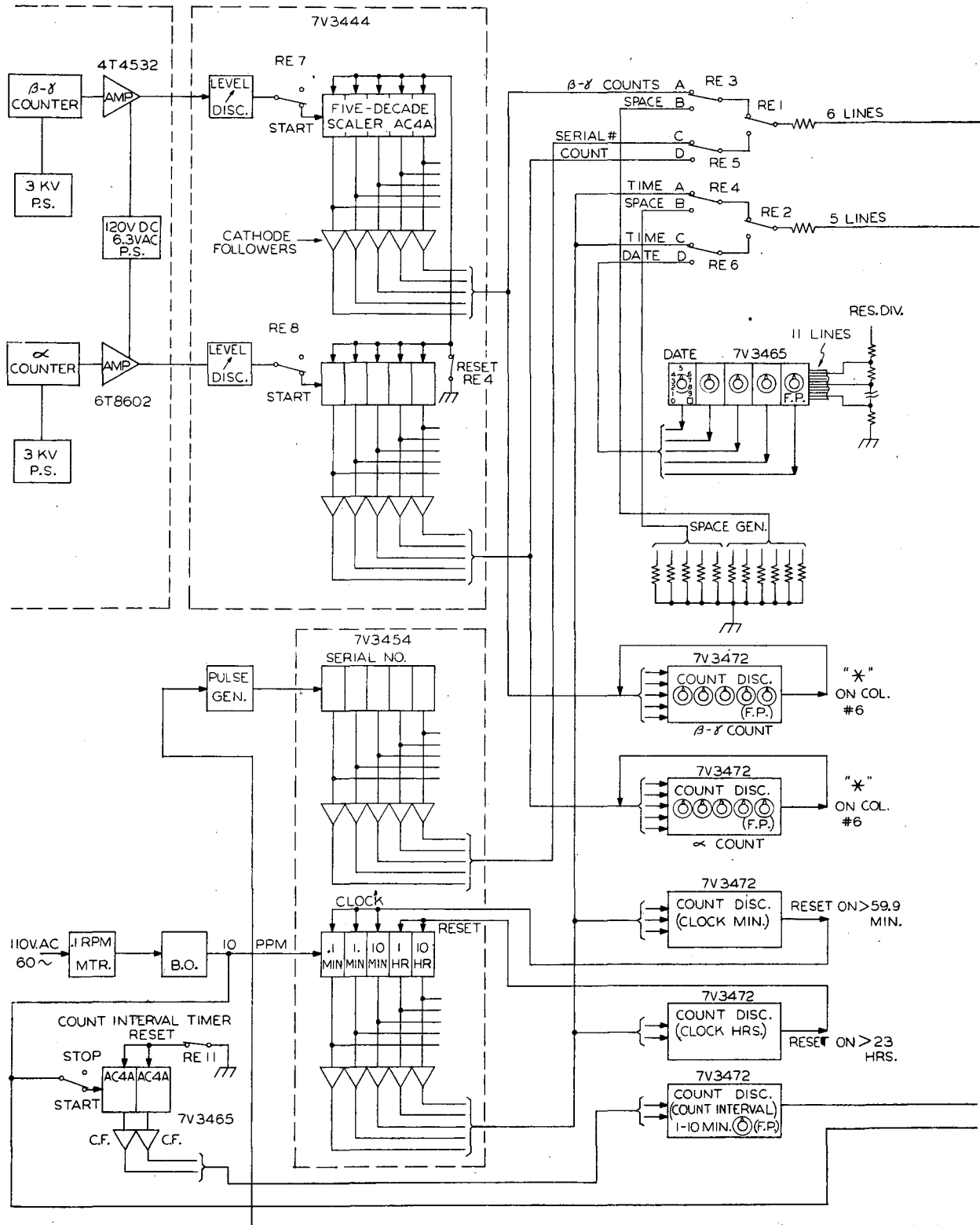

Fig. 6. The electronic control block diagram.

A signal (S-302) is taken from the printer which indicates that all the print wheels are locked. A pulse is produced from this signal which advances the programmer one position and begins another print cycle by activating the print command delay one-shot. The programmer is now in position B, the printer cycles with the print wheels in a blank position, and the S-302 signal is routed to a preset space counter and the print command delay. Thus the required number of spaces is obtained on the tape before the programmer is advanced to the next position.

A pulse from the space counter advances the programmer to C and activates the print command delay one-shot, thereby beginning a print cycle. The S-302 signal advances the programmer to D and begins another print cycle. The next S-302 signal activates the "reset" one-shot, which resets the scalars and the count interval timer; the programmer is also reset to position A and the count flip-flop is reset so that pulses may enter the scalars and the count interval timer.

The counting cycle that has been described is repeated until all the trays that have been loaded into the machine have been counted. When there is no tray to slide into counting position after the sample-advance one-shot has been activated, the microswitch that normally starts the printing cycle is not depressed. Each following clock pulse advances the tray-selecting mechanism downward until the limit switch is reached.

The 7V numbers on the block diagram are the print numbers of the schematic upon which these functional blocks are shown in detail.

Description of Circuitry

The control circuitry is transistorized and consists mostly of flip-flops and one-shots. All the transistors used are inexpensive low-speed units (2N34 and 2N35). The regenerative circuits have been tested at high temperatures and operate above 60°C. These circuits are capable of operating reliably at speeds up to 100 kc and are all followed by current amplifiers which provide sufficient drive to operate relays, pilot lamps, or low-impedance lines. The triggering sensitivity is set at 10 v, which is one-half the normal signal voltage, to provide effective noise rejection.

The space counter is a staircase counter utilizing two transistors in a blocking oscillator circuit. This circuit provides an easily adjustable division ratio from 1 to 10. The division ratio is adjusted by the ratio of two capacitors. The input pulse height is standardized by a zener diode, and the voltage staircase is stored on a capacitor.

The count discriminator circuit is capable of monitoring the staircase outputs of five AC4A decade scalars or their equivalents. When all the numbers that are represented by the staircase voltages exceed the numbers preset for each decade that is being monitored, a dc Schmitt trigger circuit is activated. This Schmitt trigger is designed so that it may be latched in the event that the decade scalars exceed their maximum count and reset to zero, thus an indication may still be made that the preset number has been exceeded. The circuit is normally unlatched when the scalars are reset.

All transistor circuitry is mounted on general-purpose printed-circuit boards. These boards are approximately 4-1/2x7-in. and fit into standard bins that hold 20 boards. The boards have etched copper lands for 14 transistor sockets and tie points for associated components; they have a standard 22-pin printed circuit connector at one end, and are gold-plated to prevent oxidation in storage. A typical board holds three standard flip-flops, including the input-trigger amplifier and output-current amplifier.

The vacuum tube scalars were chosen because they were commercially available and would operate the Hewlett-Packard 560A printer directly. The Hewlett-Packard AC-4A decade scalars operate at a maximum rate of 120 kc and have a double-pulse resolution of 7μsec. These specifications were thoroughly adequate for this application. Twenty-two AC-4A decade scalars are used in the system: five each of the α counter, β-γ counter, serial number counter, and clock, and two for the count-interval timer.

Reliability of function in operation is always of interest. Perhaps the best over-all evaluation of this factor is expressed in the man-months of maintenance required, as follows:

January 1959	0.55
February	0.25
March	0.05
April	0.1
May	0.14
June	0.48
July	0.0
August	0.18
September	0.1

Since the reader operates approximately 340 hours per month, the reliability is considered acceptable. The component failures to date have included two vacuum tubes and two high-voltage power transformers. The remainder of maintenance time has been devoted to mechanical components, primarily the printer.

The integrity of the system is checked by placing standard samples and blanks in the machine with each batch of unknowns. Sensitivity-adjustment knobs enable the operator to correct the response of the instrument in cases of minor drift.

The present routine supplies information for field action in less than 24 hours after sampling ceases. By former routines 48 or more hours elapsed (unless an unacceptably high number of man-hours were employed). The ability to identify many of the shorter-lived radioisotopes--by determining decay constants--has likewise contributed to early intelligent action in controlling such materials in laboratories where many isotopes are dealt with. Figure 7 is a specimen of such data.

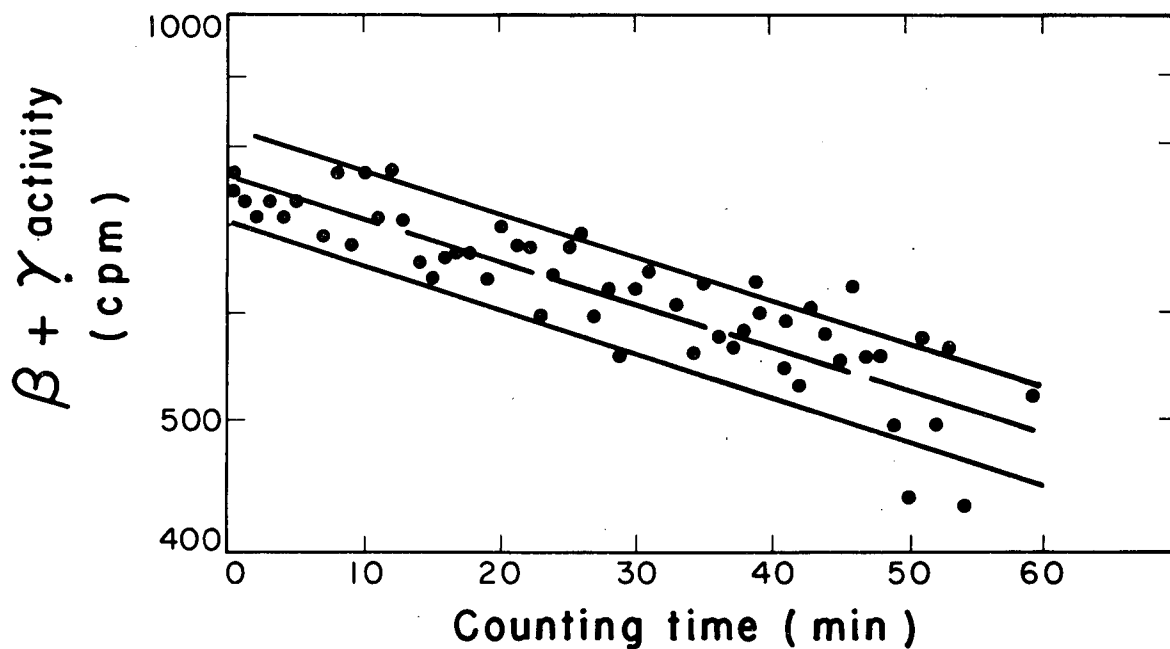

MU-18446

Fig. 7. Decay curve from scattergram: activity as a function of time for 24-hr air sample. Data from automatic reader for sample taken in Bldg. 19, Rm. 86, ending at 0900 9/16/59. Slope fitted by eye. Conclusion: 94-minute half life.

Acknowledgments

The authors are indebted to Gary Ewing, B. D. Abram, and John Bowen for their contributions to the design of this device.

This work was done under the auspices of the U. S. Atomic Energy Commission.

This report was prepared as an account of Government sponsored work. Neither the United States, nor the Commission, nor any person acting on behalf of the Commission:

- A. Makes any warranty or representation, expressed or implied, with respect to the accuracy, completeness, or usefulness of the information contained in this report, or that the use of any information, apparatus, method, or process disclosed in this report may not infringe privately owned rights; or
- B. Assumes any liabilities with respect to the use of, or for damages resulting from the use of any information, apparatus, method, or process disclosed in this report.

As used in the above, "person acting on behalf of the Commission" includes any employee or contractor of the Commission, or employee of such contractor, to the extent that such employee or contractor of the Commission, or employee of such contractor prepares, disseminates, or provides access to, any information pursuant to his employment or contract with the Commission, or his employment with such contractor.